

User Manual

Preparing Aircraft and Battery

Exiting Packing Mode

The aircraft enters Packing Mode to enable easy packing during transportation. It is required to disable Packing Mode when using the aircraft on its first use.

1. Plug in both Intelligent Flight Batteries onto the aircraft. Powering on to exit Packing Mode.
2. Press and release on the power button on the Intelligent Flight Batteries for up to 5 times to exit Packing Mode.

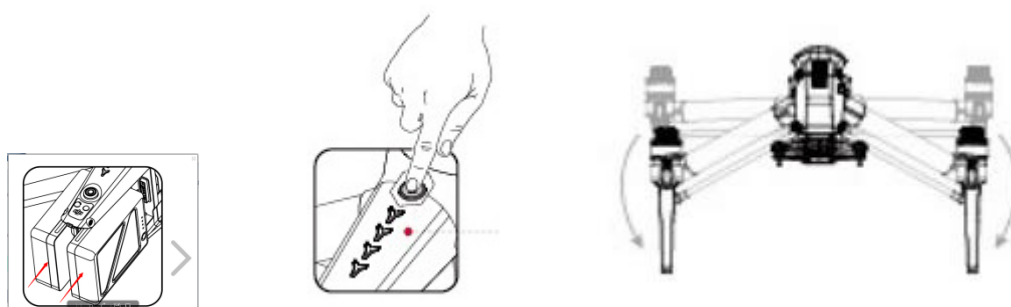

Installing Camera and Gimbal

Power off the aircraft.

1. Press and hold the mounting button on the gimbal mount.
2. Align the white dot on the camera connector with the red dot on the gimbal mount, follow by mounting the camera onto the gimbal mount.
3. Rotate the locking ring on the camera so that the red dot on the camera is aligned with the red dot on the gimbal mount.

Using the Remote Controller

Press and release the power button on the remote controller, wait for 3 seconds then press and hold the power button to power on the remote controller.



Aircraft Diagram

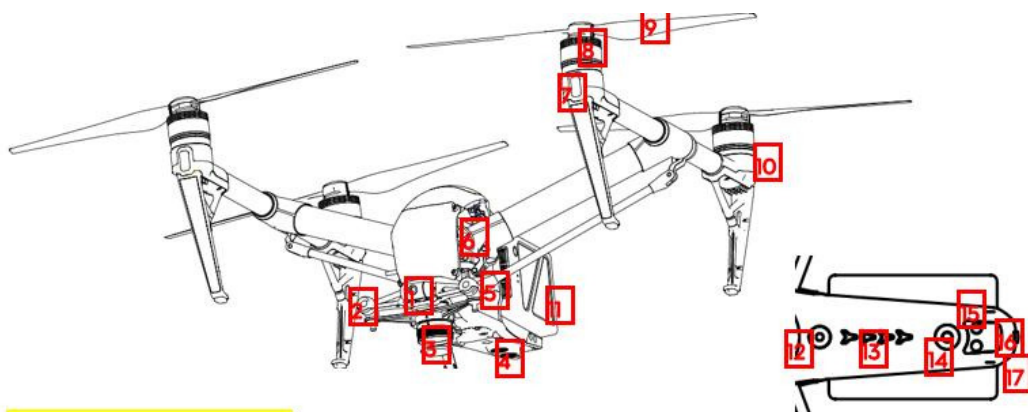

1. FPV (First Personal View) Camera
2. Obstacle Sensing System
3. Quick Release Mount
4. Vision Positioning System
5. Landing Gear Servo
6. Graphic Processing System
7. Front LED
8. Motor
9. Propellers
10. Rear LED
11. Intelligent Flight Battery
12. Power Button
13. Battery Level Indicator

- 14. Battery Eject Button
- 15. Top Sensor
- 16. Aircraft Status Indicator
- 17. SSD Port
- 18. USB Port
- 20. USB Mode Button
- 21. Link Button

Remote Controller Diagram

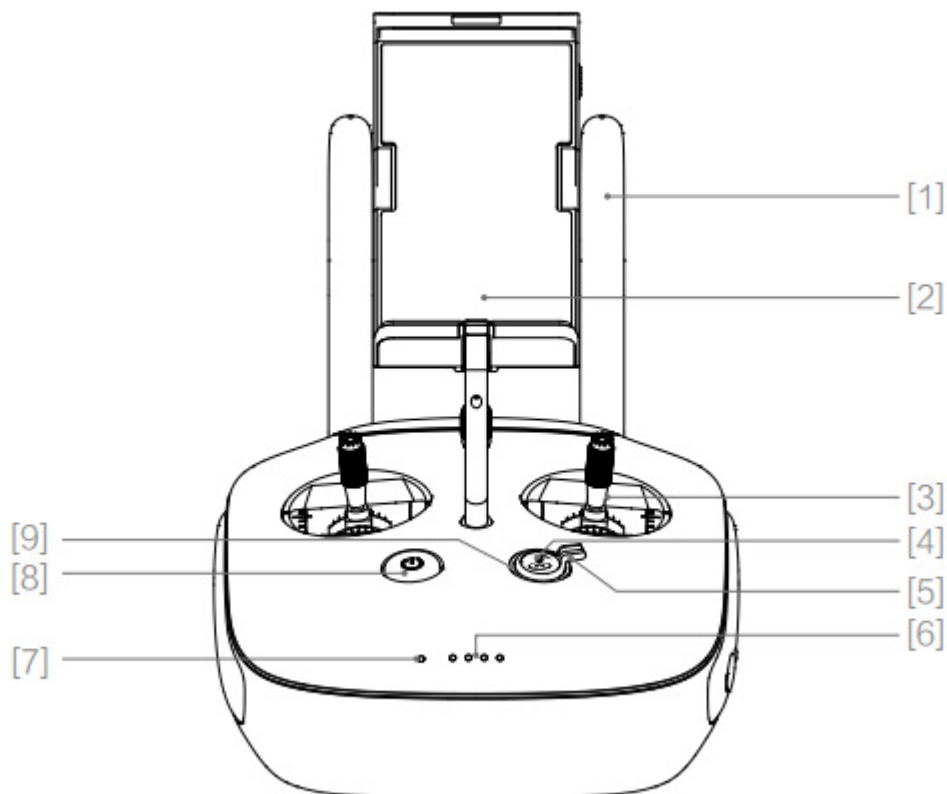

- [1] Antennas
Relays aircraft control and video signal.
- [2] Mobile Device Holder
Securely mounts your mobile device to the remote controller.
- [3] Control Stick
Switch between Mode 2 and Mode 1 by using the DJI GO app.
- [4] RTH Button
Press and hold the button to initiate Return to Home (RTH).

[5] Transformation Switch

This switch comprises of two options.

Toggle this switch to lower or retract the landing gear.

[5] Battery Level LEDs

Displays the battery level of the remote controller.

[7] Status LED

Displays the remote controller's system status.

[7] Power Button

Used to turn the remote controller on and off.

[8] RTH LED

Circular LED around the RTH button displays RTH status.

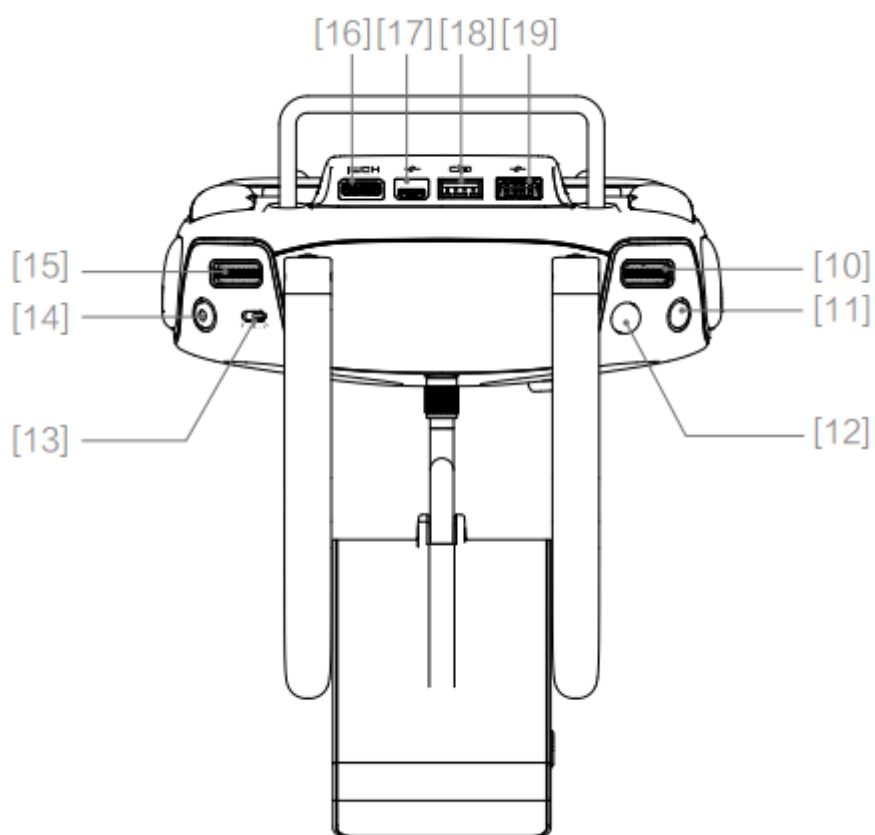

[10] Camera Settings Dial

Turn the dial to adjust camera settings.

[11] Pause Button

Press this button to pause the current operations including Tapfly, Follow me.

[13] Shutter Button

Press to take a photo.

[12] Flight Mode Switch

Use this switch to switch between

A(Atti), S(Sports) and P(Positioning) mode.

[14] Record Button

Press to start recording video.

[15] Gimbal Dial

Tilt Gimbal

[16] HDMI Port

Use this port to relay HDMI signal to HDMI devices

[17] Micro USB Port

Reserve for future use.

[18] CAN Port

Reserve for future use.

[19] USB Port

Connect to mobile device for running the DJI GO app.

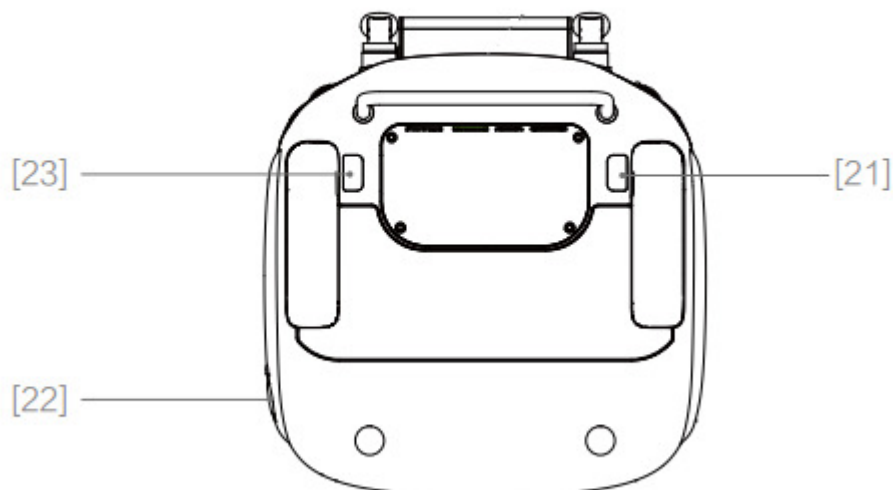

[21] C1 Button

[22] Power Port

Connect to the Charging Hub to charge the battery of the remote controller.

[23] C2 Button

Using the Remote Controller

Press once to check the battery level from the battery level LEDs. Follow the steps below

to turn on your remote controller:

1. The Battery Level LEDs will display the current battery level.
2. Press once, then again and hold to turn on/off Remote Controller.
3. Repeat Step 2 to turn off the remote controller.

Battery

Turning ON/OFF

Slide both the batteries into the battery slots on the rear of the aircraft until it is securely attached on the slots.

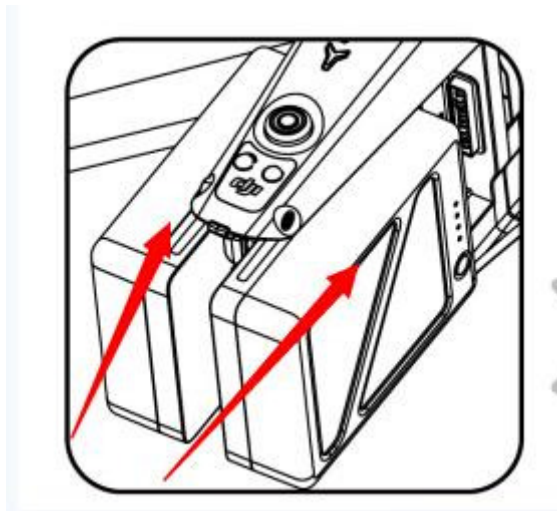

Turning On: Press the Power Button once, then press again and hold for 2 seconds to turn on. The Power LED will turn red and the remote controller system status screen will display the current battery level.

Turning Off: Press the Power Button once, then press again and hold for 2 seconds to turn off. Power level indicators turn off when it is power down. The battery power LED will flash when powering off the Phantom to allow automatically stopping of a recording during the event recording wasn't stopped.

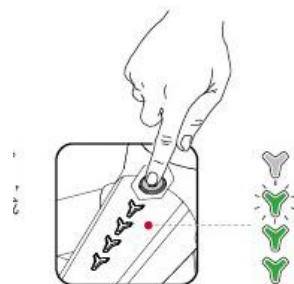

Remove the Intelligent Flight Battery

Press the curricula Battery Eject button to eject both the batteries from the aircraft.

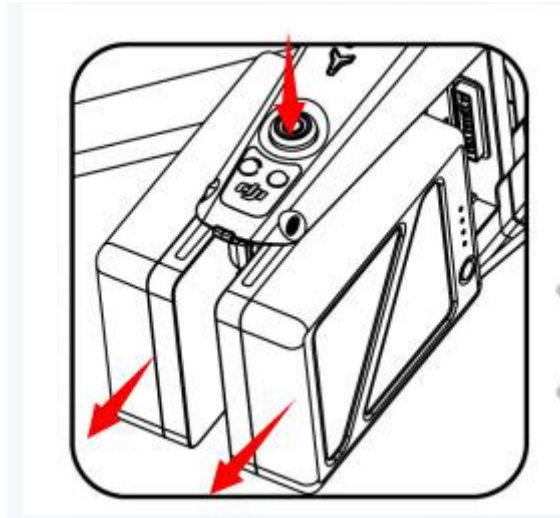

Charging the Batteries

1. Connect the Battery Charger to a power source (100-240 V 50/60 Hz).
2. Connect the one end of the Battery Charger to the supplied Charging Hub to start charging.
3. The Battery Level Indicator will display the current battery level as it is charging.
4. The Intelligent Flight Battery is fully charged when the Battery Level Indicators are all off. The Battery Level Indicators will turn off when charging is complete. Detach the batteries from the Charging Hub.

Allow its temperature to drop to room temperature before storing it for an extended period.

The charger will stop charging the battery if the battery cell's temperature is not within the operating range (5°C to 40°C).

Powering on aircraft and remote controller

1. Power on the remote controller before powering the aircraft.
2. Launch the DJI GO app and enter "Camera" view.

Starting/Stopping the Motors

Starting the Motors

A Combination Stick Command (CSC) is used to start the motors. After the motors start, release both control sticks.

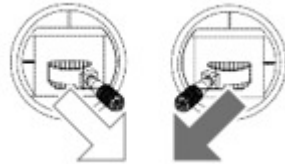

Stopping the Motors

There are two methods to stop the motors. When Phantom 4 has landed, push the left stick down, then conduct the same CSC that was used to start the motors, as described above. Release both sticks once motors stop. When the aircraft has landed, push and hold the left stick down.

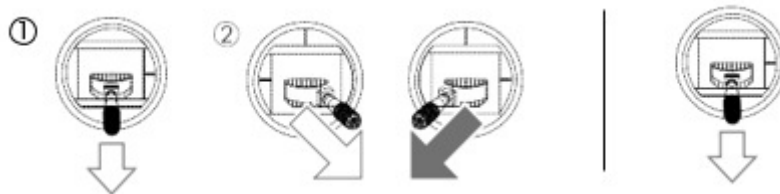

Specifications

	Model	T650A
Aircraft	Weight (Battery & Propellers Included)	3375g

	Diagonal Distance (Propellers Excluded)	605mm
	Max Ascent Speed	6 m/s (Sport mode)
	Max Descent Speed	4 m/s (descending) / 7m/s(diving)
	Max Speed	20 m/s (Sport mode)
	Max Service Ceiling Above Sea Level	6000m
	Flight Time	25miin
	Operating Temperature	-10°C to 40°C
	Satellite Positioning Systems	GPS/GLONASS
	Hovering Precision	Vertical +/- 0.1 m (VPS enabled); +/- 0.5 m Horizontal: +/- 0.3 m (VPS enabled); +/- 1.5 m
Gimbal	Controllable Range	Pitch: -90° to +30° roll: -90° to +30° pan: ±320°
	Stabilization	3-axis (pitch, roll, pan)
Obstacle Sensing System	Obstacle Sensing Range	Front: 0.7 - 30 m 0-8m (Top ToF sensing range) 0-4m
	FOV	Forward sensing: Horizontal Range: 60°, Vertical Range: 54° ±5°
	Detecting Range	Forwarding: 10 Hz, Upward: 20Hz
	Operating Environment	Front view: Surfaces with clear patterns and adequate lighting (lux > 15) surface with distinctive patterns
Vision Positioning Status	Velocity Range	≤ 22.4mph (36kph) at 6.6ft (2m) above ground
	Altitude Range	0m to10m
	Operating Range	0m to10m
	Detecting Frequency	10 Hz
	Operating Environment	Surfaces with clear patterns and adequate lighting (lux > 15)
Altitude Sensing System	Altitude Range	5cm-500cm
	Detecting Range	1 cm
	Detecting Frequency	20Hz
	Operating Environment	Surface with no sound absorbing features.
	Model	GL6D10A

Remote Controller	Max Transmission Distance	FCC: 5000 m ; CE: 3500 m (2.4 GHz no interference, unobstructed) FCC: 5000 m ; CE: 2000 m (5.8 GHz no interference, unobstructed)
	Operating Temperature	0°C to 40°C
	Battery	6000 mAh LiPo 2S
	Operating Voltage	7.4V @ 1.2A

FCC Compliance Notice

This device complies with Part 15 of the FCC Rules. Operation is subject to the following two conditions: (1) This device may not cause harmful interference, and (2) This device must accept any interference received, including interference that may cause undesired operation.

Any changes or modifications not expressly approved by the party responsible for compliance could void the user’s authority to operate the equipment.

This equipment has been tested and found to comply with the limits for a Class B digital device, pursuant to part 15 of the FCC Rules. These limits are designed to provide reasonable protection against harmful interference in a residential installation. This equipment generates, uses and can radiate radio frequency energy and, if not installed and used in accordance with the instructions, may cause harmful interference to radio communications. However, there is no guarantee that interference will not occur in a particular installation. If this equipment does cause harmful interference to radio or television reception, which can be determined by turning the equipment off and on, the user is encouraged to try to correct the interference by one or more of the following measures:

- Reorient or relocate the receiving antenna.
- Increase the separation between the equipment and receiver.
- Connect the equipment into an outlet on a circuit different from that to which the receiver is connected.
- Consult the dealer or an experienced radio/TV technician for help.

RF Exposure Information

T650A complies with FCC radiation exposure limits set forth for an uncontrolled environment. In order to avoid the possibility of exceeding the FCC radio frequency exposure limits, human proximity to the antenna shall not be less than 20cm during normal operation.

For model GL6D10A, SAR tests are conducted using standard operating positions accepted by the FCC/IC with the device transmitting at its highest certified power level in all tested frequency bands, although the SAR is determined at the highest certified power level, the actual SAR level of the device while operating can be well below the maximum value. Before a new model is available for sale to the public, it must be tested and certified to the FCC/IC that it does not exceed the exposure limit established by the FCC/IC, Tests for each product are performed in positions and locations as required by the FCC/IC. For Handheld operation, this device has been tested and meets the FCC RF exposure guidelines when used with an accessory designated for this product or when used with an accessory that contains no metal.

IC RSS Warning

This device complies with Industry Canada licence-exempt RSS standard (s). Operation is subject to the following two conditions: (1) this device may not cause interference, and (2) this device must accept any interference, including interference that may cause undesired operation of the device.

Le présent appareil est conforme aux CNR d'Industrie Canada applicables aux appareils radio exempts de licence.

L'exploitation est autorisée aux deux conditions suivantes:

- (1) l'appareil ne doit pas produire de brouillage, et
- (2) l'utilisateur de l'appareil doit accepter tout brouillage radioélectrique subi, même si le brouillage est susceptible d'en compromettre le fonctionnement.

IC Radiation Exposure Statement:

This equipment complies with IC RF radiation exposure limits set forth for an uncontrolled environment. This transmitter must not be co-located or operating in conjunction with any other antenna or transmitter.

T650A should be installed and operated with minimum distance 20cm between the radiator & your body.

Cet appareil est

conforme aux limites d'exposition de rayonnement RF IC établies pour un environnement non contrôlé.

Cet émetteur ne doit pas être co-implanté ou fonctionner en conjonction avec toute autre antenne ou transmetteur.

T650A doit être installé et utilisé avec une distance minimale de 20cm entre le radiateur & votre corps.

Any Changes or modifications not expressly approved by the party responsible for compliance could void the user's authority to operate the equipment.

KCC Warning Message

“해당 무선설비는 운용 중 전파혼신 가능성이 있으므로 인명안전과 관련된 서비스는 할 수 없습니다.”

“해당 무선설비는 운용 중 전파혼신 가능성이 있음”

NCC Warning Message

低功率電波輻射性電機管理辦法

第十二條 經型式認證合格之低功率射頻電機，非經許可，公司、商號或使用者均不得擅自變更頻率、加大功率或變更原設計之特性及功能。

第十四條 低功率射頻電機之使用不得影響飛航安全及干擾合法通信；經發現有干擾現象時，

應改善至無干擾時方得繼續使用。前項合法通信，指依電信法規定作業之無線電通信。低功率射頻電機須忍受合法通信或工業、科學及醫療用電波輻射性電機設備之干擾。

EU Compliance Statement: SZ DJI TECHNOLOGY CO., LTD. hereby declares that this device is in compliance with the essential requirements and other relevant provisions of the R&TTE Directive. A copy of the EU Declaration of Conformity is available online at www.dji.com/euro-compliance



EU contact address: DJI GmbH, Industrie Strasse. 12, 97618, Niederlauer, Germany