

PHANTOM 3

Standard

User Manual V1.0

2015.04

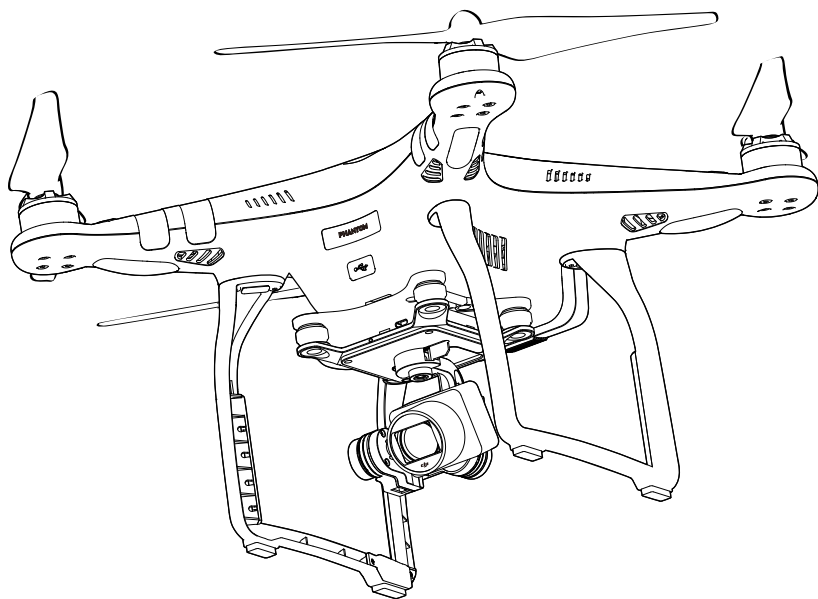

Using this manual

Legends



Warning



Important



Hints and Tips



Reference

Read Before the First Flight

Read the following documents before using the Phantom 3 Standard:

1. *In the Box*
2. *Phantom 3 Standard User Manual*
3. *Phantom 3 Standard Quick Start Guide*
4. *Phantom 3 Standard Guidelines and Disclaimer*
5. *Phantom 3 Standard Intelligent Flight Battery Safety Guidelines*

We recommend that you watch all tutorial videos on the official DJI website and read the Disclaimer before you fly. Prepare for your first flight by reviewing the Phantom 3 Standard Quick Start Guide and refer to the User Manual for more detailed information.

Video Tutorials

Please watch the tutorial videos at the link below, which demonstrates how to use Phantom 3 Standard aircraft
<http://www.dji.com/product/phantom-3/video>



Download the DJI Pilot app

Download and install the DJI Pilot app before using the aircraft. Scan the QR code to the right to download the latest version.

The Android version of the DJI Pilot app is compatible with Android 4.1.2 or later.
The iOS version of the DJI Pilot app is compatible with iOS 8.0 or later.



Contents

Using this manual	
Legends	2
Read Before the First Flight	2
Video Tutorials	2
Download the DJI Pilot app	2
Product Profile	
Introduction	6
Feature Highlights	6
Preparing the Aircraft	7
Aircraft Diagram	8
Remote Controller Diagram	8
Aircraft	
Flight Controller	11
Flight Mode	11
Flight Status Indicator	11
Return-to-Home (RTH)	12
Smart RTH	12
Low Battery RTH	13
Failsafe RTH	14
Vision Positioning System	14
Flight Recorder	16
Attaching and Detaching the Propellers	16
DJI Intelligent Flight Battery	17
Remote Controller	
Remote Controller Profile	23
Using the Remote Controller	23
Remote Controller Status LED	27
Linking the Remote Controller	28
Remote Controller Compliance Version	29

Camera and Gimbal

Camera Profile	31
Gimbal	32

DJI Pilot App

Camera	35
Director	38
Store	38
Discovery	38

Flight

Flight Environment Requirements	40
Flight Limits and No-Fly Zones	40
Preflight Checklist	44
Calibrating the Compass	44
Auto Takeoff and Auto Landing	45
Flight Test	46
Starting/Stopping the Motors	46

Troubleshooting (FAQ)

Appendix

Specifications	53
Intelligent Orientation Control (IOC)	55
FCC Compliance	56

Product Profile

This section introduces the Phantom 3 Standard and lists the components of the aircraft and remote controller.

Product Profile

Introduction

The Phantom 3 Standard represents the next generation of DJI quadcopters. It is capable of capturing 1080P video and video signal out of the box. The built-in camera has an integrated gimbal to maximize stability while minimizing both weight and size.

Feature Highlights

Camera and Gimbal: With the Phantom 3 Standard, you're shooting 1080p video and capturing 12 megapixel photos that look crisper and cleaner than ever. An enhanced sensor gives you greater clarity, lower noise, and better pictures than any previous flying camera.

DJI Intelligent Flight Battery: The 4480 mAh DJI Intelligent Flight Battery features upgraded battery cells and an advanced power management system.

Built-in WiFi Extender: The wifi extender is integrated into the remote controller to allow a easy connection to teh aircraft.

Flight Controller: The next-generation flight controller has been updated to provide a safer, more reliable flight experience. A newly implemented flight recorder stores critical data from each flight.

Preparing the Aircraft

Removing Gimbal Clamp

Remove the gimbal clamp by sliding it to the right (when facing the nose of the aircraft), as shown below.

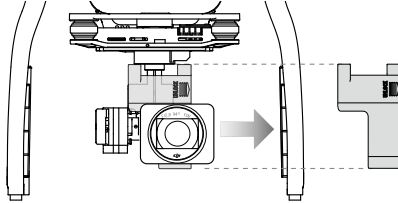

Attaching the Propellers:

Mount the propellers with black dots on to motors with black axes and spin counter-clockwise to secure. Mount the propellers with silver dots on to motors with silver axes and spin clockwise to secure. Be sure all propellers are securely in place.

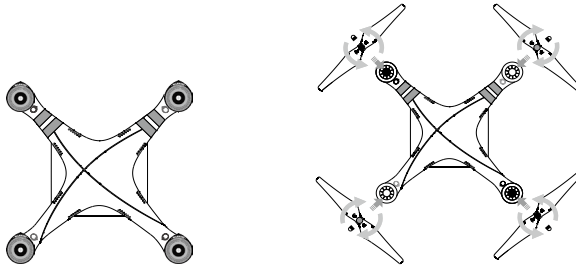

Place all propellers onto the correct motors and tighten by hand to lock them in position.

Preparing the Remote Controller:

1. Twist the Phone Holder to face outwards and fix in position.
2. Ensure the battery is fully charged.
3. Be sure S1 and S2 are switched to the upper most position. The LED will go green if the Remote Controller is functioning.

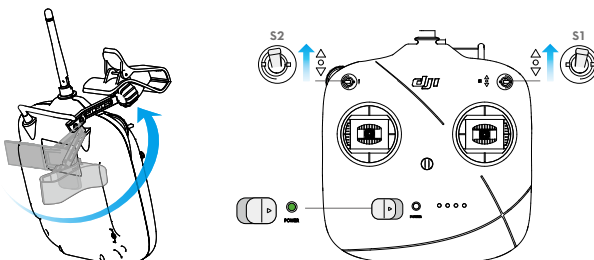

Aircraft Diagram

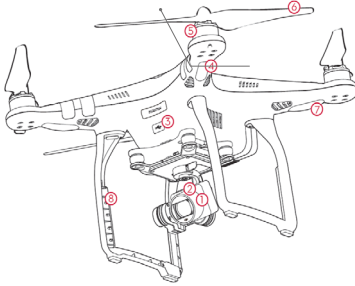

- [1] Gimbal and Camera
- [2] Camera Micro-SD Card Slot
- [3] Aircraft Micro-USB Port
- [4] Front LED Indicator
- [5] Landing gear
- [6] Motor
- [7] Rear LED Indicator
- [8] Antennas

Remote Controller Diagram

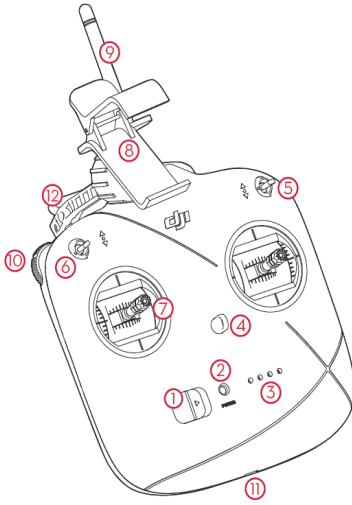

- [1] Power Button
- [2] Status LED
- [3] Battery Level LEDs
- [4] Neck Strap Securing Hole
- [5] S1 Switch
- [6] S2 Switch
- [7] Control Stick
- [8] Phone Holder
- [9] Antennas
- [10] Gimbal Dial
- [11] Charging Port

Aircraft

This section introduces the features of the Flight Controller, Vision Positioning System, and the Intelligent Flight Battery

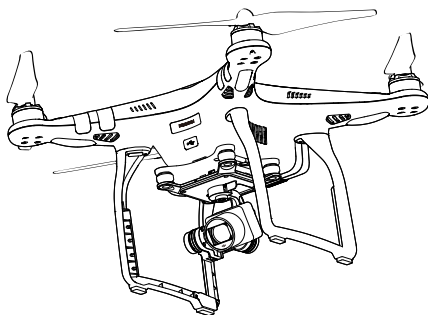

Aircraft

Flight Controller

The Phantom 3 Standard's flight controller features several important upgrades, including a new flight mode. Safety modes include Failsafe and Return-to-Home. These features ensure the safe return of your aircraft if the control signal is lost. The flight controller can also save critical flight data from each flight to the on-board storage device. The new flight controller also provides increased stability.

Flight Mode

Two flight modes are available. The details of each flight mode are found below:

P-mode (Positioning) : P-mode works best when GPS signal is strong. There are three different states of P-mode, which will be automatically selected by the Phantom 3 Standard depending on signal strength of GPS.

P-GPS: GPS and Vision Positioning both are available. The aircraft is using GPS for positioning.

P-ATTI: Neither GPS nor Vision Positioning is available. The aircraft is using only its barometer for positioning, so only altitude can be stabilized.

A-mode (Attitude): GPS is not used for stabilization. The aircraft only uses its barometer. The aircraft can still automatically return to the home point if the control signal is lost and the Home Point was recorded successfully.

F-mode (Function): Intelligent Orientation Control (IOC) is activated in this mode. For more information about IOC, refer to the IOC section in the Appendix.



Use the Flight Controller mode switch to change the flight mode of the aircraft, refer to the ["Flight Mode Switch"](#) on Page 26 for more information.

Flight Status Indicator



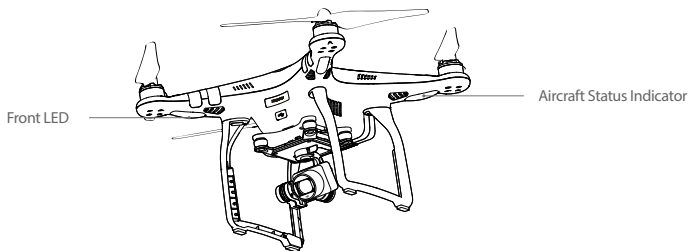

The Phantom 3 Standard has Front LEDs and Aircraft Status Indicators. The positions of these LEDs are shown in the figure below:









The Front LEDs show the orientation of the aircraft. The Front LEDs glow solid red when the aircraft is turned on to indicate the front (or nose) of the aircraft. The Aircraft Status Indicators communicate the system status of the flight controller. Refer to the table below for more information about the Aircraft Status Indicators:

Aircraft Status Indicator Description

Normal



 Red, Green and Yellow Flash Alternately	Turning On and Self Diagnostic Testing
 Green and Yellow Flash Alternately	Warming Up
 Green Flashes Slowly	Safe to Fly (P-mode with GPS and Vision Positioning)
 X2 Green Flashes Twice	Safe to Fly (P-mode with Vision Positioning but without GPS)
 Yellow Flashes Slowly	Safe to Fly (A-mode but No GPS and Vision Positioning)

Warning

 Fast Yellow Flashing	Remote Controller's Signal Lost
 Slow Red Flashing	Low Battery Warning
 Fast Red Flashing	Critical Battery Warning
 Red Flashing Alternately	IMU Error
 — Solid Red	Critical Error
 Red and Yellow Flash Alternately	Compass Calibration Required

Return-to-Home (RTH)

The Return-to-Home (RTH) function brings the aircraft back to the last recorded Home Point. There are three types of RTH procedures: Smart RTH, Low Battery RTH, and Failsafe RTH. This section describes these three scenarios in detail.

	GPS	Description
Home Point		If a strong GPS signal was acquired before takeoff, the Home Point is the location from which the aircraft was launched. The GPS signal strength is indicated by the GPS icon (). The aircraft status indicator will blink rapidly when the home point is recorded.

Smart RTH

Use the RTH button on the remote controller (refer to “RTH button” on page 26 for more information) or tap the RTH button in the DJI Pilot app and follow the on-screen instructions when GPS is available to initiate Smart RTH. The aircraft will then automatically return to the last recorded Home Point. You may use the remote controller's control sticks to control the aircraft's position to avoid a collision during the Smart RTH process. Press and hold the Smart RTH button once to start the process, and press the Smart RTH button again to terminate the procedure and regain full control of the aircraft.

Low Battery RTH

The low battery level failsafe is triggered when the DJI Intelligent Flight Battery is depleted to a point that may affect the safe return of the aircraft. Users are advised to return home or land the aircraft immediately when prompted. The DJI Pilot app will display a notice when a low battery warning is triggered. The aircraft will automatically return to the Home Point if no action is taken after a ten-second countdown. The user can cancel the RTH procedure by pressing the RTH button on the remote controller. The thresholds for these warnings are automatically determined based on the aircraft's current altitude and distance from the Home Point.

The aircraft will land automatically if the current battery level can only support the aircraft long enough to descend from its current altitude. The user can still use the remote controller to alter the aircraft's orientation during the landing process.

The Battery Level Indicator is displayed in the DJI Pilot app, and is described below:

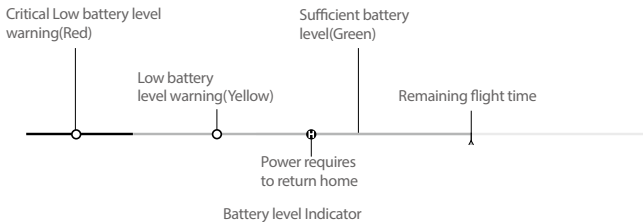

Battery Level Warning	Remark	Aircraft Status Indicator	DJI Pilot app	Flight Instructions
Low battery level warning	The battery power is low. Please land the aircraft.	Aircraft status indicator blinks RED slowly.	Tap "Go-home" to have the aircraft return to the Home point and land automatically, or "Cancel" to resume normal flight. If no action is taken, the aircraft will automatically go home and land after 10 seconds. Remote controller will sound an alarm.	Fly the aircraft back and land it as soon as possible, then stop the motors and replace the battery.
Critical Low battery level warning	The aircraft must land immediately.	Aircraft status indicator blinks RED quickly.	The DJI Pilot app display will flash red and the aircraft will start to descend. The remote controller will sound an alarm.	Allow the aircraft to descend and land automatically.
Estimated remaining flight time	Estimated remaining flight based on current battery level.	N/A	N/A	N/A



- When Critical battery level warning is triggered and the aircraft begins to land automatically, you may push the throttle upward to make the aircraft hover at its current altitude, giving you an opportunity to navigate to a more appropriate landing location.
- The colored zones and markers on the battery level indicator bar reflect the estimated remaining flight time. They are automatically adjusted according to the aircraft's current location and status.

Failsafe RTH

If the Home Point was successfully recorded and the compass is functioning normally, Failsafe RTH will be automatically activated if the remote controller signal is lost for more than three seconds. The Return-to-Home process may be interrupted and the operator may regain control of the aircraft if the remote controller signal connection is re-established.

Failsafe Illustration

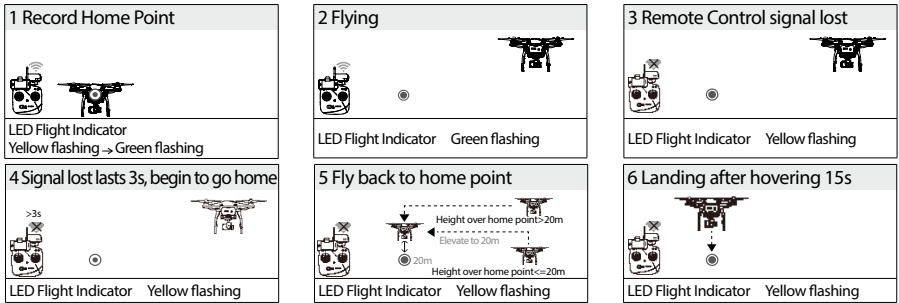





- The aircraft cannot avoid obstruction during the Failsafe RTH, therefore, it is important to set an suitable Failsafe altitude before each flight. Launch the DJI Pilot app and enter “Camera” and select “MODE > Advanced Settings > Failsafe mode” to set the Failsafe altitude.
- The aircraft will stop its ascent and return to the Home Point immediately if the throttle stick is moved during the Failsafe RTH procedure.

Flight Recorder

Flight data is automatically recorded to the internal storage of the aircraft. This includes flight telemetry, aircraft status information, and other parameters. To access these data, connect the aircraft to the PC through the Micro-USB port and launch the DJI Pilot app.

Attaching and Detaching the Propellers

Use only DJI approved propellers with your Phantom 3 Standard. The grey and black nuts on the propeller indicate where they should be attached and in which direction they should spin. To attach the propellers properly, match the nut color with the motor axis color.

Propellers	Silver Dot	Black Dot
Figure		
Attach On	Motors with a grey axes	Motors with a black axes
Legends	 Lock: Turn the propellers in the indicated direction to mount and tighten.  Unlock: Turn the propellers in the indicated direction to loosen and remove.	

Attaching the Propellers

1. Be sure to remove the warning stickers from the motors before attaching the propellers.
2. Attach the propellers with silver dots onto the motors with silver axes and spin the propellers clockwise to secure them in place. Attach the propellers with black dots onto the motors with black axes and spin the propellers counter-clockwise to secure them in place. Be sure to tighten each propeller by hand before flight.

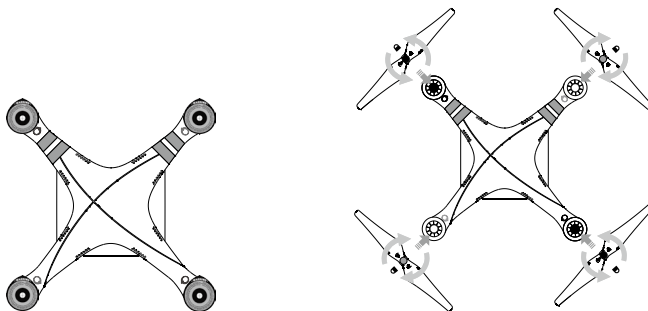

- ⚠ • Ensure propellers are attached to its corresponding motors, otherwise the aircraft cannot take off.
- Wear gloves when handling propellers.
- Hand tighten each of the propellers on the corresponding motors to ensure it is attached firmly.

Detaching the Propellers

Hold the motor in place with one hand, then spin the propeller in the indicated unlock direction.

- ⚠ • Check that the propellers and motors are installed correctly and firmly before every flight.
- Ensure that all propellers are in good condition before each flight. DO NOT use aged, chipped, or broken propellers.
- To avoid injury, STAND CLEAR of and DO NOT touch propellers or motors when they are spinning.
- ONLY use original DJI propellers for a better and safer flight experience.

DJI Intelligent Flight Battery

The DJI Intelligent Flight Battery has a capacity of 4480 mAh, a voltage of 15.2 V, and a smart charge/discharge functionality. It should only be charged using an appropriate charger that has been approved by DJI.

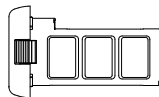

Intelligent Flight Battery

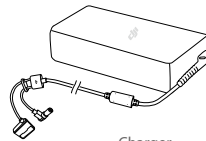

Charger

- ⚠ The Intelligent Flight Battery must be fully charged before using it for the first time. Refer to "Charging the Intelligent Flight Battery" for more information.

💡 Be aware that the output power of the supplied Phantom 3 Standard charger is 100W.

DJI Intelligent Flight Battery Functions

1. Battery Level Display: the LED indicators display the current battery level.
2. Battery Life Display: the LEDs display the current battery power cycle.
3. Auto-Discharging Function: To prevent swelling, the battery automatically discharges to below 65% of total power when it is idle for more than ten days. It takes around two days to discharge the battery to 65%. It is normal to feel moderate heat being emitted from the battery during the discharge process. Discharge thresholds can be set in the DJI Pilot app.
4. Balanced Charging: Automatically balances the voltage of each battery cell when charging.
5. Overcharge Protection: Charging automatically stops when the battery is fully charged.
6. Temperature Detection: The battery will only charge when the temperature is between 0°C (32°F) and 40°C (104°F).
7. Over Current Protection: The battery stops charging when high amperage (more than 8 A) is detected.
8. Over Discharge Protection: To prevent over-discharge damage, discharging automatically stops when the battery voltage reaches 12 V.
9. Short Circuit Protection: Automatically cuts the power supply when a short circuit is detected.

10. Battery Cell Damage Protection: The DJI Pilot app displays a warning message when a damaged battery cell is detected.
11. Battery Error History: Browse the battery error history in the DJI Pilot app.
12. Sleep Mode: To save power, the battery enters sleep mode after 20 minutes of inactivity.
13. Communication: Information pertaining to the battery's voltage, capacity, current, etc. is transmitted to the aircraft's main controller.

 Refer to *Phantom 3 Standard Intelligent Flight Battery Safety Guidelines* before use. Users take full responsibility for all operations and usage.

Using the Battery

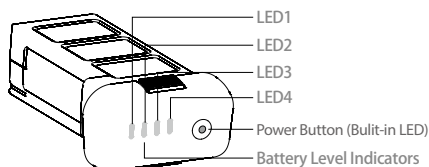

Turning ON/OFF

Turning On: Press the Power Button once, then press again and hold for 2 seconds to turn on. The Power LED will turn red and the Battery Level Indicators will display the current battery level.

Turning Off: Press the Power Button once, then press again and hold for 2 seconds to turn off. The battery power LED will flash when powering off the Phantom to allow automatically stopping of a recording during the event recording wasn't stopped.

Low Temperature Notice:

1. Battery capacity is significantly reduced when flying in low temperature ($< 0^{\circ}\text{C}$) environments.
2. It is not recommended that the battery be used in extremely low temperature ($< -10^{\circ}\text{C}$) environments. Battery voltage should reach the appropriate level when operating environment with temperatures between -10°C and 5°C .
3. End the flight as soon as the DJI Pilot app displays the "Low Battery Level Warning" in low temperature environments.
4. Keep the battery indoors to warm it before flying in low temperature environments.
5. To ensure optimal performance of the battery, keep the battery temperature above 20°C .
6. The charger will stop charging the battery if the battery cell's temperature is not within the operating range ($0^{\circ}\text{C} \sim 40^{\circ}\text{C}$).





































 In cold environments, insert the battery into the battery compartment and allow the aircraft for approximately 1-2 minutes to warm up before taking off.

Checking the Battery Level

The Battery Level Indicators display how much power remains. When the battery is turned off, press the Power Button once. The Battery Level Indicators will light up to display the current battery level. See below for details.





































 The Battery Level Indicators will also show the current battery level during charging and discharging. The indicators are defined below.

 : LED is on.  : LED is flashing.
 : LED is off.

Battery Level				
LED1	LED2	LED3	LED4	Battery Level
				87.5%~100%
				75%~87.5%
				62.5%~75%
				50%~62.5%
				37.5%~50%
				25%~37.5%
				12.5%~25%
				0%~12.5%
				=0%

Battery life

Battery life refers to how many more times the battery can be discharged and recharged before it must be replaced. When the battery is turned off, press and hold the Power Button for 5 seconds to check the battery life. The Battery Level Indicators will light up and/or blink for two seconds, as shown below:

Battery Life				
LED1	LED2	LED3	LED4	Battery Life
				90%~100%
				80%~90%
				70%~80%
				60%~70%
				50%~60%
				40%~50%
				30%~40%
				20%~30%
				below 20%

 When battery life reaches 0%, it can no longer be used.

 For more information about the battery, launch the DJI Pilot app and check the information that is listed under the battery tab.

Charging the Intelligent Flight Battery

1. Connect the Battery Charger to a power source (100-240 V 50/60 Hz).
2. Open the Protection Cap and connect the Intelligent Flight Battery to the Battery Charger. If the battery level is above 95%, turn on the battery before charging.
3. The Battery Level Indicator will display the current battery level as it is charging.
4. The Intelligent Flight Battery is fully charged when the Battery Level Indicators are all off.
5. Air-cool the Intelligent Flight Battery after each flight. Allow its temperature to drop to room temperature before storing it for an extended period.



- We do not recommend charging the Intelligent Flight Battery and remote controller with the standard charger at the same time, otherwise the charger may overheat.
- Always turn off the battery before inserting it or removing it from the Phantom 3 Standard. Never insert or remove a battery when it is turned on.

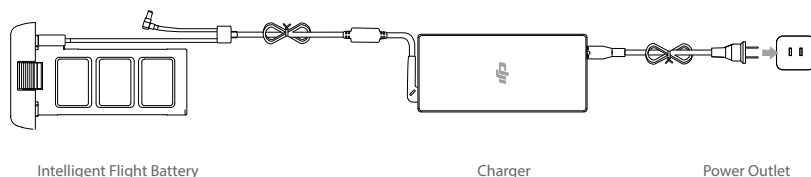

Battery Level Indicators While Charging

LED1	LED2	LED3	LED4	Battery Level
				0%~25%
				25%~50%
				50%~75%
				75%~100%
				Fully Charged

Battery Protection LED Display

The table below shows battery protection mechanisms and corresponding LED patterns.

Battery Level Indicators while Charging

LED1	LED2	LED3	LED4	Blinking Pattern	Battery Protection Item
				LED2 blinks twice per second	Over current detected
				LED2 blinks three times per second	Short circuit detected
				LED3 blinks twice per second	Over charge detected
				LED3 blinks three times per second	Over-voltage charger detected
				LED4 blinks twice per second	Charging temperature is too low
				LED4 blinks three times per second	Charging temperature is too high

After these issues are resolved, press the Power Button to turn off the Battery Level Indicator. Unplug the Intelligent Flight Battery from the charger and plug it back in to resume charging. Note that you do not need to unplug and plug in the charger in the event of a room temperature error; the charger will resume charging when the temperature is within the allowable range.



DJI does not take any responsibility for damage caused by third-party chargers.



How to discharge your Intelligent Flight Battery:

Slow : Place the Intelligent Flight Battery into the Phantom 3 Standard's battery compartment and turn it on. Leave it on until there is less than 8% of power left, or until the battery can no longer be turned on. Launch the DJI Pilot app to check battery levels.

Rapid : Fly the Phantom 3 Standard outdoors until there is less than 8% of power left, or until the battery can no longer be turned on.

Remote Controller

This section describes the features of the remote controller and includes instructions for controlling the aircraft and the camera.

Remote Controller

Remote Controller Profile

The Phantom 3 Standard remote controller is a multi-function wireless communication device that includes aircraft remote control system. The wireless transmission system operates at 5.8 GHz while the WiFi Range Extender is operating at 2.4GHz. The remote controller features a number of camera control functions, such as taking and previewing photos and videos, as well as controlling gimbal motion. The remote controller is powered by a 2S rechargeable battery. The battery level is displayed via LED indicators on the front panel of the remote controller.

- ☰ • Compliance Version: The remote controller is compliant with both CE and FCC regulations.
- Operating Mode: Control can be set to Mode 1 or Mode 2, or to a custom mode.
- Mode 1: The right stick serves as the throttle.
- Mode 2: The left stick serves as the throttle.

⚠ To prevent transmission interference, do not operate more than three aircrafts in the same area.

Power on the Remote Controller

- (1) Set S1 and S2 switches to the upper most position and place all sticks in the mid-point.
- (2) Toggle power switch to the right to switch on.
- (3) There will be a power on indicator beep. If the remote control is set to be CE compliant, then there will be one beep, while the FCC compliant version will emit two beeps. The battery level indicator displays the current battery level. The indicator will blink green quickly, indicating the remote control and receiver are linking. Once fully linked, the power indicator will change to a solid green.

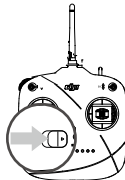











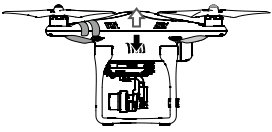

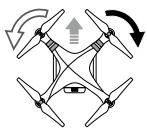

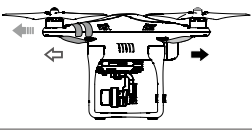
- ⚠ • If the low voltage warning alert sounds (refer to [Remote Control Power LED Status Information \(Page 17\)](#) for details), please recharge the battery as soon as possible.
- Using the incorrect type of charging cable may cause damage.
- Recharge the battery after extended period storage.

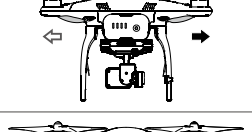
Remote Control Operation

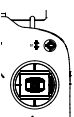
The Remote Control is set to Mode 2 by default.

-  • Stick Neutral/ mid point: Control sticks of the Remote Control are placed at the central position.
- Move the Stick: The control stick is pushed away from the central position.

Remote Control (Mode 2)	Aircraft ( indicates nose direction)	Operation details
		Vertical movements on the left stick control elevation. Push the stick up to ascend and down to descend. When both sticks are centered the Phantom will hover in place. Push the throttle stick upward beyond the centered (neutral) position to take off. Push the throttle gently to prevent sudden and unexpected elevation.
		Horizontal movements on the left stick control the rudder. Push left to rotate counter clock-wise and right for clockwise. If the stick is centered, the Phantom will fly straight. The more the stick is moved, the faster the Phantom will rotate.
		Vertical movements on the right stick control forward and backward pitch. Push up to fly forward and down to fly backward. The Phantom will hover in place if the stick is centered. Push the stick further for a larger pitch angle (maximum 35°) and faster flight.
		Horizontal movements on the right stick control left and right pitch. Push left to fly left and right to fly right. The Phantom will hover in place if the stick is centered. Push the stick further for a larger pitch angle (maximum 35°) and faster flight.
		Left Dial: Turn the dial to the right, and the camera will shift to point upwards. Turn the dial to the left, and the camera will shift to point downwards. The camera will keep its current position if the dial is static.
	 Position 1 Position 2 Position 3	The S1 switch is used for compass calibration. Toggle the S1 from position 1 to position 3 and back approximately 5 times to enter into compass calibration mode. In Naza-M mode, the S1 switch is used to switch between control modes and enter compass calibration.
	 Position 1 Position 2 Position 3	S2 is used to record a Home point manually. After a Home point has been recorded automatically, flipping S2 from position 1 to position 3 and back 5 times (or more) rapidly will move the Home point to the Phantom's current location. In addition, you can enable Dynamic Home Point feature in DJI VISION App. In Naza-M working mode, S2 is be used for IOC.

Battery Level Indicator

Built-in LiPo Battery: The remote control includes a rechargeable LiPo battery with a capacity of 2000mAh. You can monitor the current battery level using the LED indicators on the front panel of the remote control as the figure shown:

- ⚠ The remote control will show a blinking LED and sound an alert when the voltage drops below 3.45V, then automatically power off after 3 seconds. This process will repeat even if you power cycle the remote control. If this low voltage warning occurs during flight, the remote control will automatically power off, causing the aircraft to enter Failsafe mode, which cannot be interrupted (refer to Failsafe Function (Page27) for details). It is strongly recommended that you recharge the battery immediately when the 3.45V-3.5V low voltage warning occurs.

Antenna Orientation

Keep the antennas pointing skyward, perpendicular to the ground for maximum remote control range during flight.

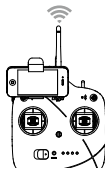

For maximum range and reliability, Remote Control antenna should point skywards with no obstructions between it and the Phantom. Obstacles may cause Return to Home to trigger. Phone Holder should not block the antenna.

Linking the Remote Control and Receiver

A 5.8G receiver is built in to the Phantom 3 Standard aircraft. Its link button and indicator are located on the underside of the phantom, as shown in Figure 26.



The Remote Control and the receiver are paired before delivery. Only use this button if you have replaced your Remote Control or receiver.

Linking Procedures

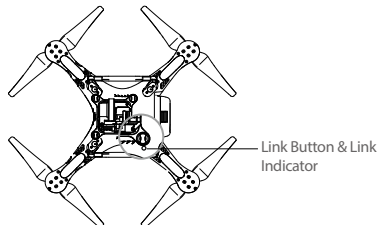
- (1) Power off the Remote Control, power on the aircraft. You will see the link indicator blinking red.
- (2) Press the link button with a thin object and hold until the link indicator blinks yellow. Release the link button.
- (3) Power on the Remote Control. Link indicator will switch off, showing that a link has been successfully established.



Link Indicator

Link Indicator	Description	Next Operation
 Red flashing	No signal received.	Switch on the Remote Control or perform a link procedure.
 Yellow flashing	Ready to link.	Switch on the Remote Control.



5.8 Compliance Version Configuration

As power levels vary between regulators, the Phantom Remote Control's power output can be adjusted by twisting the CE/FCC Control Knob (Figure 27) on the back of the Remote Control using a flathead screwdriver. For CE compliance, set the Remote Control to CE with a full counterclockwise turn. For FCC compliance, set the Remote Control to FCC with a full clockwise turn. Be sure to follow relevant local regulations.

Compliance can be configured using the PHANTOM RC Assistant. Select CE compliance version in Assistant to set it, or do the same with FCC compliance version.

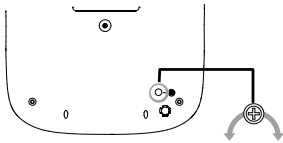





Remote Controller



-  Turn the CE/FCC Control knob gently to avoid damage.
 - CE compliant devices have an effective remote control range of 400 meters in open spaces due to power limitations.
 - FCC compliant devices have an effective range of 800 meters in open spaces.
 - Watch your flight distance as the Phantom 3 Standard aircraft will enter Failsafe mode (auto-landing or go home and land) if it flies beyond the relevant range limits.
 - Always follow local laws and regulations.
-
-  It is recommended to use a $\Phi 2.4\text{mm}$ flathead screwdriver for adjustments.
 - There is another potentiometer for reserved use.

- ⚠ • If the low voltage warning alert sounds (refer to [Remote Control Power LED Status Information \(Page 17\)](#) for details), please recharge the battery as soon as possible.
- Using the incorrect type of charging cable may cause damage.
- Recharge the battery after extended period storage.

Remote Control Power LED Status Information

Power LED Indicator	Sound	Remote Control Status
 — Solid Green	None	Functioning normally.
 — Solid Red	None	Charging(remote control is powered off)
 — Solid Yellow	None	Remote control joysticks calibration error, need to be re-calibrate.
 — Solid Red	BB—BB—BB	Low voltage (from 3.5V-3.53V), recharge the remote control.
Quick Red flashing	B-B-B.....	Critical low voltage (from 3.45V-3.5V). Recharge the remote control immediately.
Slow Green flashing	B--B--B.....	Alert will sound after 15 minutes of inactivity. It will stop once you start using the remote control.

Camera and Gimbal

This section provides the technical specifications of the camera and explains the gimbal's operation modes.