

# MG-1P / MG-1P RTK

## Quick Start Guide

V1.0

# Aircraft(Model: 3WWDSZ-10016/3WWDSZ-10017)

The Agras MG-1P series (MG-1P / MG-1P RTK) aircraft is equipped with a wide-angle FPV camera, observing the operating environment in front to offer reality references for planning operation area and flying with obstacle avoidance remotely. The second generation high-precision radar, integrated the forward, backward and downward altitude stabilization radar modules and obstacle avoidance radar module, improves its functions of obstacle sensing and terrain following.

The aircraft body, using new structures and materials, is dust-proof, water-proof (IP43 protection rating, IEC standard 60529) and anti-corrosive.

The MG-1P / MG-1P RTK contains DJI's dedicated A3 redundancy system with eight-rotor propulsion redundancy, ensuring safe and stable operation at all times. The MG-1P RTK has a built-in DJI Onboard D-RTK\*, which provides more accurate data for centimeter-level positioning.

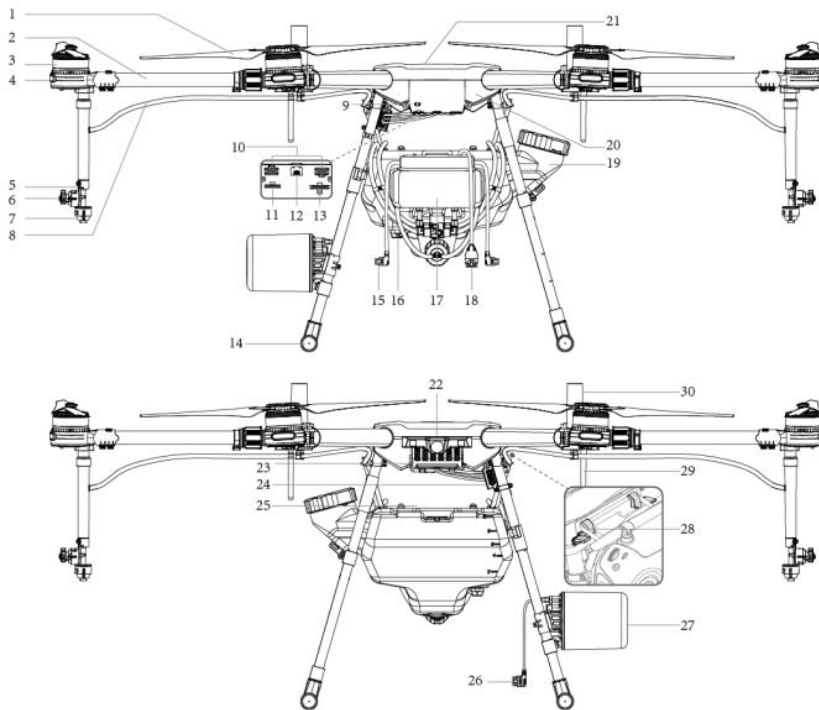

- |                                      |                                       |  |
|--------------------------------------|---------------------------------------|--|
| 1 Propellers                         | 12 Micro USB Port                     | 23 Intake Vent                                 |
| 2 Frame Arms                         | 13 Flow Meter Port                    | 24 Power Port                                  |
| 3 Motors                             | 14 Landing Gear                       | 25 Battery Compartment                         |
| 4 ESC LED                            | 15 Pump Cables                        | 26 Radar Cable                                 |
| 5 Sprinklers                         | 16 Flow Meter                         | 27 Radar Module                                |
| 6 Relief Valve                       | 17 Delivery Pumps                     | 28 Remote Controller Holder                    |
| 7 Nozzles                            | 18 Flow Meter Cable                   | 29 OcuSync Antenna                             |
| 8 Hoses                              | 19 Spray Tank                         | 30 Onboard D-RTK Antennas (for MG-1P RTK only) |
| 9 Link Button (rear of the aircraft) | 20 Aircraft Body                      |  |
| 10 Pump Ports                        | 21 GNSS Module                        |  |
| 11 Radar Port                        | 22 FPV Camera (front of the aircraft) |  |

- DO NOT obstruct the GNSS module located at the center of the aircraft, as this will reduce the GPS signal strength.
- The MG-1P / MG-1P RTK does not come with a battery. Please purchase the DJI approved battery pack (Model: MG-12000P).

\* This should be used with a DJI Base Station (purchased additionally) or DJI approved Network RTK service.

# Remote Controller(Model: GL300N)

Fully upgraded remote controller uses second-generation DJI OcuSync dual-band video downlink system which has a maximum control distance of up to 3 km. The remote controller is equipped with a bright, dedicated screen with a built-in brand new DJI MG app. Operation area planning supports using both the remote controller and aircraft to set waypoints. Smooth turning of the operation route is added, with the new spraying system, making flight and operation more flexible and efficient. The remote controller features a function of multi-drone control with a single remote controller. It can coordinate up to five drones for operation at the same time, which further improves the efficiency of a single operator. Replaceable batteries and antennas of the remote controller make it easy for daily operation and maintenance.

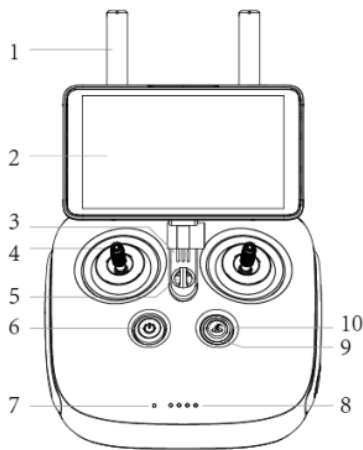

- |                      |                      |
|----------------------|----------------------|
| 1 Antennas           | 6 Power Button       |
| 2 Display Device     | 7 Status LED         |
| 3 Speaker            | 8 Battery Level LEDs |
| 4 Control Sticks     | 9 RTH Status LED     |
| 5 Lanyard Attachment | 10 RTH Button        |

For example, the following description uses Mode 2. The left stick controls the aircraft altitude and heading, while the right stick controls its forward, backward, left and right movements.

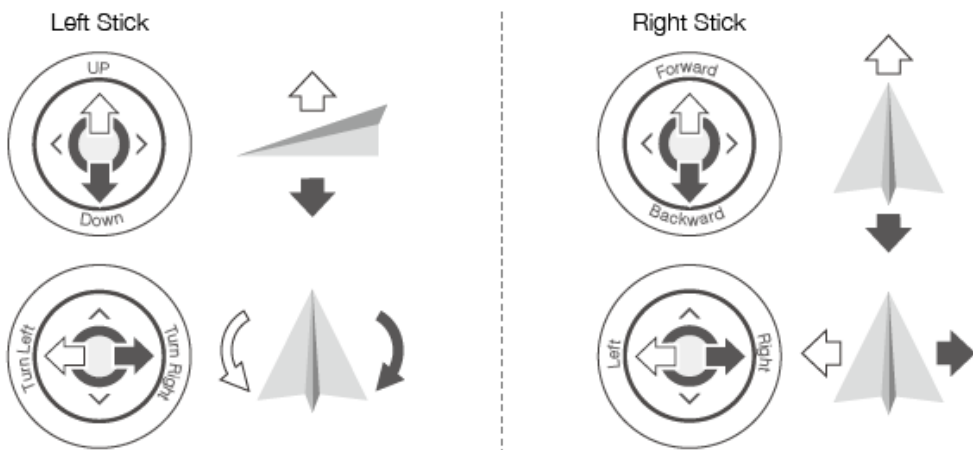

## Installation

- Threadlocker of medium strength is required for installation. Apply threadlocker when mounting the

landing gear, power port module, spray tank, sprinklers and radar module. Ensure threadlocker is totally dry and solid before flight.

- DO NOT bend the hose in an arc tighter than its minimum bend radius during installation. This is to avoid creasing, which may compromise the spraying effect.
- Ensure that all installation and connection procedures are completed before powering on the aircraft.

## Mounting the Battery

Insert the battery into the battery compartment from the front of the aircraft. Ensure the battery is securely mounted and then buckle the belt to the button of the spray tank.

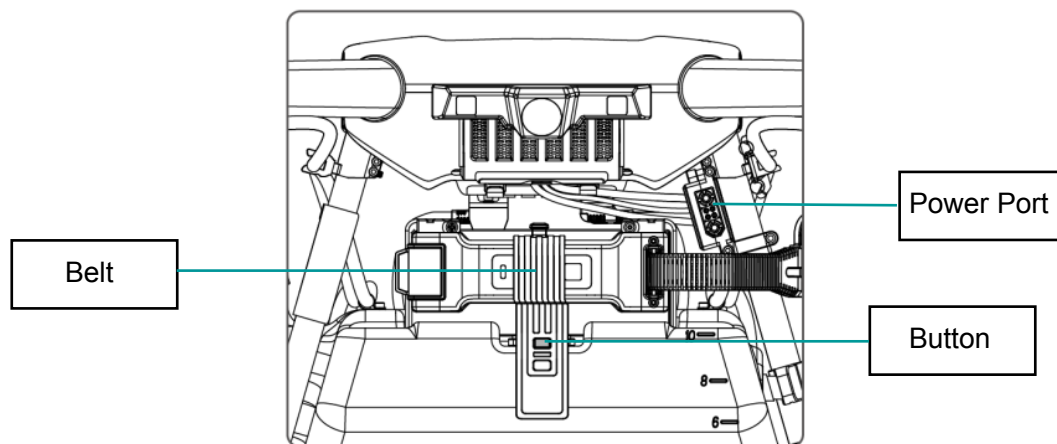

- TheMG-1P/ MG-1P RTK does not come with a battery. Please purchase the DJI approved MG-1S battery pack (Model: MG-12000P).
- The voltage on the aircraft can reach 50.4 V. Read the battery's safety guidelines and take necessary precautions when handling the battery to ensure your own safety.

## Fly Safe

It is important to understand some basic flight guidelines, both for your protection and for the safety of those around you.

1. Flying in Open Areas: Do not fly near or above people or animals, or near buildings, power lines and other obstacles.
2. Maintain Control at All Times: Always keep your hands on the remote controller and maintain control of your aircraft when it is in flight, even when using intelligent functions such as Intelligent Operating Planning System, Smart Operation Mode and Smart Return-to-Home.
3. Maintain Line of Sight: Maintain a line of sight to your aircraft at all times and avoid flying behind buildings or other obstacles that may block your view.

4. Monitor Your Altitude: For the safety of full-sized aircraft and other air traffic, always fly at altitudes less than 164 feet (50 meters) or according to local laws and regulations.



Visit <https://www.dji.com/flysafe/geo-map> for more information on critical safety features such as No Fly Zones.

## Return-to-Home

It is important to take off with a strong GNSS signal to ensure that the Home Point is recorded by the aircraft. The aircraft will automatically return to the Home Point in the following cases.

Smart RTH: You press the RTH button.

Failsafe RTH\*: Remote controller signal is lost.

The aircraft can sense obstacles at a distance up to 30 meters, then automatically avoid obstacle and fly to the Home Point.

\* The Failsafe RTH must be enabled in the DJI MG app. If not enabled, the aircraft will hover in place when remote controller signal is lost.

## Using MG-1P/ MG-1P RTK

### Preparing the Flight Battery

Only use DJI approved flight batteries (Model: MG-12000P). Check battery level before flying and charge according to instructions provided by the manufacturer.

### Preparing the Remote Controller

#### Checking Battery Level

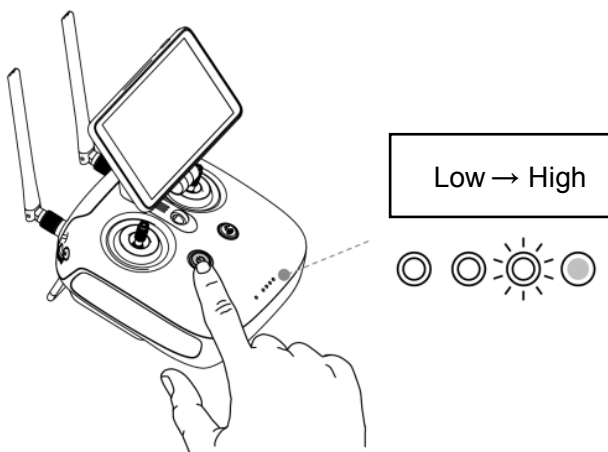

Press once to check the battery level. Press once, then again and hold to turn on/off.

### Charging the Battery

Press the battery level button once to check the battery level. Fully charge the batteries before

first-time use.

1. Place the battery into the Charging Hub, connect the charger to the Charging Hub, and then connect the charger to a power outlet (100 - 240V, 50/60Hz).

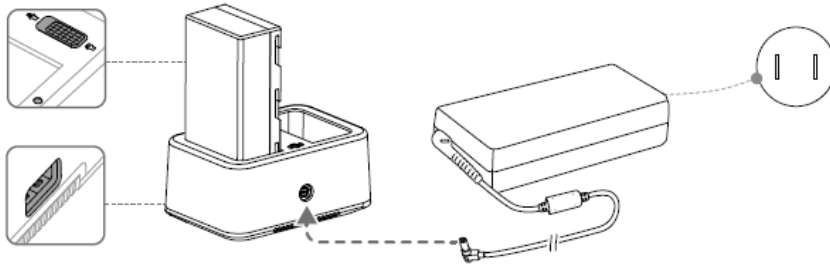

2. The Charging Hub will intelligently charge batteries in sequence according to battery power levels from high to low.

3. The Status LED blinks green when charging and turns solid green when fully charged. The buzzer will begin beeping when charging is complete. Remove the battery or turn off the buzzer to stop it.

### Adjusting the Antennas

Tilt the display device on the remote controller to the desired position, then adjust the antennas so they are facing outward. The strength of the remote controller signal will fluctuate depending on the position of the antennas.

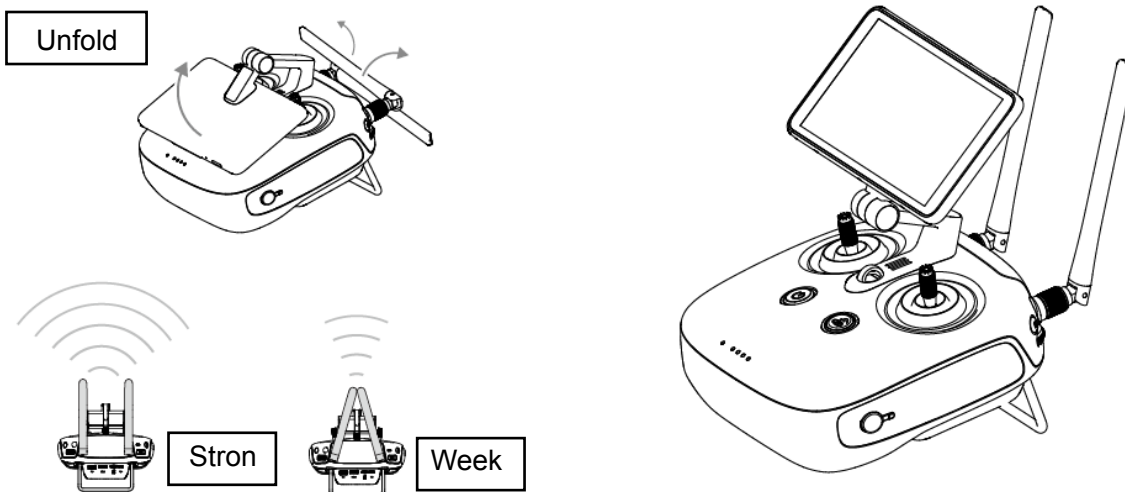

Try to keep the aircraft inside the optimal transmission range. If the signal is weak, adjust the antennas or fly the aircraft closer.

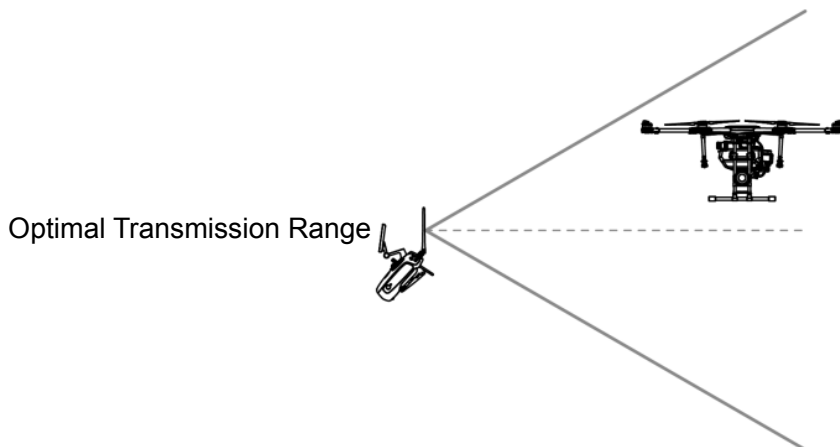

- Avoid using wireless devices that use the same frequency bands as the remote controller.

## Getting Ready for Takeoff

When using your MG-1P / MG-1P RTK for the first time, activate it in the DJI MG app. Your DJI account and internet connection are required.

1. Place the aircraft on an open, flat ground with the Aircraft Status Indicator facing towards you.
2. Unfold the propellers and check that they are mounted onto the motors securely. Unfold frame arms and tighten arm sleeves firmly.
3. Power on the remote controller.
4. Ensure the battery is securely mounted. Connect the battery to the power port on the aircraft.

## Flight

Enter the Operation View of the DJI MG app. Ensure that there is a strong GNSS signal and the operation mode is M mode (Manual). Otherwise the aircraft cannot take off.

## Takeoff

Perform the Combination Stick Command (CSC) and then slowly push the throttle stick up to take off.

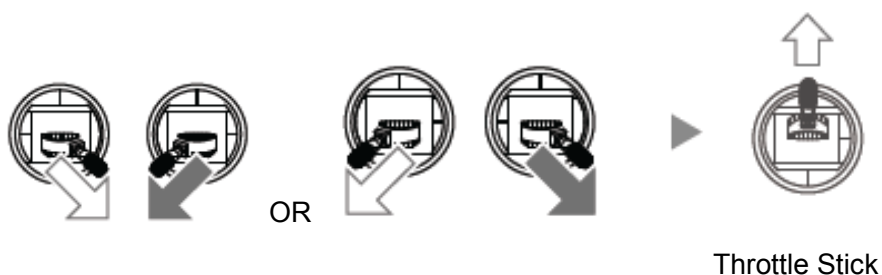

## Landing

To land, pull down on the throttle stick down to descend until the aircraft touches the ground. There are two methods to stop the motors.

1. When the aircraft has landed, push the throttle down and hold. The motors will stop after 3 seconds.

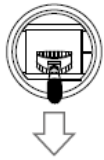

Throttle Stick

2. When the aircraft has landed, push the throttle stick down, then perform the CSC command to stop the motors. Release both sticks once the motors have stopped.



Throttle Stick

### Intelligent Operation Planning System

The remote controller equips a highlighted screen with a built-in Android system, which can run the DJI MGapp. Measure operation area and obstacles, configure waypoints, and other settings via the intelligent operationplanning system built-in the app, and the app will produce a flight route according to the settings. The aircraft canoperate automatically following the flight route.

## Specifications

Airframe	
Diagonal Wheelbase	1500 mm
Frame Arm Length	619mm
Dimensions	MG-1P: 1460 mm×1460 mm×578 mm(Frame arms unfolded, propellers removed) 780 mm×780 mm×578 mm(Frame arms folded) MG-1P RTK: 1460 mm×1460 mm×616 mm(Frame arms unfolded, propellers removed) 780 mm×780 mm×616 mm(Frame arms folded)
Diameter × Pitch	21×7 inch
Propeller Weight	58 g
Operating Frequency	2.400 GHz to 2.483 GHz 5.725 GHzto 5.850 GHz (not supported in Japan)



EIRP	<p>2.4 GHz</p> <p>FCC: ≤26 dBm, CE: ≤20 dBm,SRRC(China): ≤20 dBm, KCC(Korea): ≤18 dBm, MIC(Japan): ≤18 dBm</p> <p>5.8 GHz</p> <p>FCC: ≤26 dBm, CE: ≤14 dBm, SRRC (China): ≤26 dBm, KCC(Korea): ≤14 dBm</p>
<b>Radar Module</b>	
Model	RD2412R
Operating Frequency	<p>SRRC / CE / FCC: 24.00 GHzto 24.25 GHz</p> <p>MIC / KCC:24.05 GHzto 24.25 GHz</p>
Power Consumption	12 W
EIRP	SRRC: 13 dBm, FCC: 20 dBm, CE: 20 dBm, MIC: 20 dBm, KCC: 20 dBm
Altitude Detection and Stabilization	<p>Detection Range: 1 - 30 m</p> <p>Stabilization Working Range: 1.5 - 3.5 m</p>
IP Rating	IP67
<b>Flight Parameters</b>	
Total Weight (Excluding battery)	MG-1P: 9.7kg, MG-1P RTK: 9.9 kg
Standard Takeoff Weight	23.7 kg
Max Takeoff Weight	24.8 kg(At sea level)
Max Thrust-Weight Ratio	1.71(Takeoff weight of 23.7 kg)
GNSS	GPS+GLONASS
Battery	DJI approved battery pack (Model: MG-12000P)
Max Power Consumption	6400 W
Hovering Power Consumption	<p>3800 W(Takeoff weight of 23.7 kg)</p> <p>Hovering Time* 22 min (Takeoff weight of 14 kg with</p>
Hovering Time*	<p>20 min (Takeoff weight of 13.7 kg with a 12000 mAh battery)</p> <p>9 min (Takeoff weight of 23.7 kg with a 12000 mAh battery)</p>
Max Service Ceiling Above Sea Level	2000 m

Operating Temperature	32° to 104° F (0° to 40° C)
Remote Controller (Model: GL300N)	
Model	GL300N
Operating Frequency	2.400 GHz to 2.483 GHz 5.725 GHz to 5.850 GHz (not supported in Japan)
Max Transmitting Distance (unobstructed, free of interference)	3 km
EIRP	2.4 GHz FCC: ≤26 dBm, CE: ≤20 dBm, SRRC(China): ≤20 dBm, KCC(Korea): ≤18 dBm, MIC(Japan): ≤18 dBm 5.8 GHz FCC: ≤26 dBm, CE: ≤14 dBm, SRRC (China): ≤26 dBm, KCC(Korea): ≤14 dBm
Display Device	5.5 inch screen, 1920×1080, 1000 cd/m <sup>2</sup> , Android system, 4G RAM+16G ROM
Operating Temperature	14° to 104° F (-10° to 40° C)
Storage Temperature	Less than 3 months: -4° to 113° F (-20° to 45° C) More than 3 months: 72° to 82° F (22° to 28° C)
Charging Temperature	41° to 104° F (5° to 40° C)
Remote Controller Intelligent Battery	
Model	WB37-4920mAh-7.6V
Battery Type	LiPo battery
Capacity	4920 mAh
Voltage	7.6 V
Energy	37.39 Wh
Charging Temperature	41° to 104° F (5° to 40° C)
Charging Hub	
Model	WCH2
Input Voltage	17.3 - 26.2 V
Output Voltage and Current	8.7 V, 6 A; 5 V, 2 A
Operating Temperature	41° to 104° F (5° to 40° C)

AC Power Adapter	
Model	A14-057N1A
Voltage	17.4 V
Rated Power	57 W

## FCC Compliance Notice

This device complies with Part 15 of the FCC Rules. Operation is subject to the following two conditions: (1) This device may not cause harmful interference, and (2) This device must accept any interference received, including interference that may cause undesired operation.

Any changes or modifications not expressly approved by the party responsible for compliance could void the user's authority to operate the equipment.

This equipment has been tested and found to comply with the limits for a Class B digital device, pursuant to part 15 of the FCC Rules. These limits are designed to provide reasonable protection against harmful interference in a residential installation. This equipment generates, uses and can radiate radio frequency energy and, if not installed and used in accordance with the instructions, may cause harmful interference to radio communications. However, there is no guarantee that interference will not occur in a particular installation. If this equipment does cause harmful interference to radio or television reception, which can be determined by turning the equipment off and on, the user is encouraged to try to correct the interference by one or more of the following measures:

- Reorient or relocate the receiving antenna.
- Increase the separation between the equipment and receiver.
- Connect the equipment into an outlet on a circuit different from that to which the receiver is connected.
- Consult the dealer or an experienced radio/TV technician for help.

## RF Exposure Information

Aircraft complies with FCC radiation exposure limits set forth for an uncontrolled environment. In order to avoid the possibility of exceeding the FCC radio frequency exposure limits, human proximity to the antenna shall not be less than 20cm during normal operation.

For Remote Controller (model GL300N), SAR tests are conducted using standard operating positions accepted by the FCC with the device transmitting at its highest certified power level in all tested frequency bands, although the SAR is determined at the highest certified power level, the actual SAR level of the device while operating can be well below the maximum value. Before a new model is available for sale to the public, it must be tested and certified to the FCC that it does not exceed the exposure limit established by the FCC, Tests for each product are performed in positions and locations as required by the FCC.

For body worn operation, Remote Controller (model GL300N) has been tested and meets the FCC RF exposure guidelines when used with an accessory designated for this product or when used with an accessory that Contains no metal.

For body worn operation, GL300N has been tested and meets the FCC RF exposure guidelines when used with an accessory designated for this product or when used with an accessory that Contains no metal and that positions the handset a minimum of 10 mm from the body.

Non-compliance with the above restrictions may result in violation of RF exposure guidelines.

**EU Compliance Statement:** SZ DJI TECHNOLOGY CO., LTD. hereby declares that this device is in compliance with the essential requirements and other relevant provisions of the RED Directive.

This Aircraft must be installed and operated in accordance with provide instructions and the antenna used for this transmitter must be installed to provide a separation distance of at least 20cm from all persons and must not be co-located or operation in conjunction with any other antenna or transmitter. End-users and installers must be provide with antenna installation instructions and transmitter operating conditions for satisfying RF exposure compliance.

A copy of the EU Declaration of Conformity is available online at [www.dji.com/euro-compliance](http://www.dji.com/euro-compliance)



**Warning:** Operation of this equipment in a residential environment could cause radio interference.