



H.B. Compliance Solutions

Intentional Radiator Test Report

For the

Raveon Technologies Corporation

Data/Paging Radio Modem RV-M8S-VB

Tested under

The FCC Rules contained in Title 47 of the CFR, Part 90 for

Private Land Mobile Radio Services

July 30, 2018

Prepared for:

Raveon Technologies, Corp

2320 Cousteau Court

Vista, CA 92081

Prepared By:

H.B. Compliance Solutions

5005 S. Ash Avenue, Suite A-10

Tempe, Arizona 85282

Reviewed By:

Hoosamuddin Bandukwala



Cert # ATL-0062-E

Engineering Statement: The measurements shown in this report were made in accordance with the procedure indicated, and the emissions from this equipment were found to be within the limits applicable. I assume full responsibility for the accuracy and completeness of these measurements, and for the qualifications of all persons taking them. It is further stated that upon the basis of the measurement made, the equipment tested is capable of operation in accordance with the requirements of Part 90 of the FCC Rules under normal use and maintenance. All results contained herein relate only to the sample tested.

Report Status Sheet

| Revision # | Report Date | Reason for Revision |
|------------|---------------|---------------------|
| ∅ | July 30, 2018 | Initial Issue |

Table of Contents

| | |
|--------------------------------------------------|----|
| EXECUTIVE SUMMARY | 4 |
| 1. Testing Summary..... | 4 |
| EQUIPMENT CONFIGURATION..... | 5 |
| 1. Overview | 5 |
| 2. Test Facility..... | 6 |
| 3. Description of Test Sample | 6 |
| 4. Equipment Configuration | 6 |
| 5. Support Equipment | 6 |
| 6. Ports and Cabling Information..... | 7 |
| 7. Method of Monitoring EUT Operation..... | 7 |
| 8. Mode of Operation..... | 7 |
| 9. Modifications | 7 |
| 10. Disposition of EUT | 7 |
| Criteria for Intentional Radiators | 7 |
| 1. RF Power Output | 8 |
| 2. Modulation Characteristics..... | 11 |
| 3. Occupied Bandwidth (Emission Mask)..... | 13 |
| 4. Spurious Emissions at Antenna Terminals | 17 |
| 5. Radiated Spurious Emissions | 24 |
| 6. Frequency Stability vs Temperature | 27 |
| 7. Frequency Stability vs Voltage..... | 29 |
| 8. Transient Frequency Behavior | 31 |
| 9. Necessary Bandwidth | 33 |
| I. Test Equipment | 34 |

EXECUTIVE SUMMARY

1. Testing Summary

These tests were conducted on a sample of the equipment for the purpose of demonstrating compliance with Part 90. All tests were conducted using measurement procedure from ANSI TIA/EIA-603-D-2010 as appropriate.

| Test Name | Test Method/Standard | Result | Comments |
|-------------------------------------------------|----------------------|--------|-----------------------------------------------------------------------|
| RF Output Power | 2.1046; 90.205 | Pass | |
| Modulation Characteristics | 2.1047(a) | Pass | The EUT does not transmit voice. The device transmit data signal only |
| Occupied Bandwidth | 2.1049; 90.210 | Pass | EUT Meets Mask C & D |
| Spurious Emissions at Antenna Terminals | 2.1051; 90.210 | Pass | |
| Radiated Spurious Emissions | 2.1053; 90.210 | Pass | |
| Frequency Stability over Temperature Variations | 2.1055(a)(1); 90.213 | Pass | |
| Frequency Stability over Voltage Variations | 2.1055(d) | Pass | |
| Transient Frequency Behavior | 90.214 | Pass | |

EQUIPMENT CONFIGURATION

1. Overview

H.B Compliance Solutions was contracted by Raveon Technologies Corporation to perform testing on the Data Radio Modem under the quotation number Q18031002.

This document describes the test setups, test methods, required test equipment, and the test limit criteria used to perform compliance testing of the Raveon Technologies Corporation, Data Radio Modem.

The tests were based on FCC Part 90 Rules. The tests described in this document were formal tests as described with the objective of the testing was to evaluate compliance of the Equipment Under Test (EUT) to the requirements of the aforementioned specifications. Raveon Technologies Corporation should retain a copy of this document and it should be kept on file for at least five years after the manufacturing of the EUT has been permanently discontinued. The results obtained relate only to the item(s) tested.

| | |
|---------------------------------------|--------------------------------------------------------------------------------|
| Product Name: | Data/Paging Radio Modem |
| Model(s) Tested: | RV-M8S-VB |
| FCC ID: | SRS-M8S-VB |
| Supply Voltage Input: | Primary Power : 12 Vdc |
| Frequency Range: | 150MHz to 174MHz |
| No. of Channels: | Single Channel |
| Necessary Bandwidth | 12.5 & 25kHz |
| Type(s) of Modulation: | 2 Level FSK & 4 Level FSK |
| Range of Operation Power: | 5.0W |
| Voltage into final Transistor | 6 volts |
| Current into final Transistor | 2.5 amps |
| Emission Designator: | 8K20F1D & 11K0F1D |
| Channel Spacing(s) | None |
| Test Item: | Pre-Production |
| Type of Equipment : | Fixed |
| Antenna: | 50 ohm TNC Connector |
| Environmental Test Conditions: | Temperature: 15-35°C Humidity: 30-60% Barometric Pressure: 860-1060 mbar |
| Modification to the EUT: | None |
| Evaluated By: | Staff at H.B. Compliance Solutions |
| Test Date(s): | 04/23/2018 till 06/19/2018 |

2. Test Facility

All testing was performed at H.B. Compliance Solutions. This facility is located at 5005 S. Ash Avenue, Suite # A-10, Tempe AZ-85282. All equipment used in making physical determination is accurate and bears recent traceability to the National Institute of Standards and Technology.

Radiated Emissions measurements were performed in a GTEM chamber (equivalent to an Open Area Test Site). In accordance with §2.948(a)(3), a complete site description is contained at H.B. Compliance Solutions.

Test facility H.B. Compliance Solutions is an ANAB accredited test site. The ANAB certificate number is L2458. The scope of accreditation can be found on ANAB website www.anab.org

3. Description of Test Sample

The Raveon Technologies, RV-M8S-VB Data/Paging radio modem, is a high-speed narrow-band data communication and POCSAG paging decoding. Its microprocessor enables it to perform both as data radio modem and a paging receiver. The M8S's user interface is asynchronous digital data into and out of the M8S. Configuration of the model is via the user serial port. The components are contained in a metal enclosure. It runs off 12 Vdc via a 2 wire cord. This model transmit data in a in the 150 to 174MHz range.

4. Equipment Configuration

| Ref. ID | Name / Description | Model Number | Serial Number |
|---------|-------------------------|--------------|---------------|
| # 1 | Data/Paging Radio Modem | RV-M8S-VB | N/A |

Table 1. Equipment Configuration

5. Support Equipment

All support equipment supplied is listed in the following Support Equipment List.

| Ref ID | Name / Description | Manufacturer | Model # | Serial # |
|--------|--------------------|--------------|---------------|------------------|
| #2 | DC Power Supply | Lambda | LA-200 | LA2-AA20-1433535 |
| #3 | Laptop | Dell | Inspiron 1545 | 17934612445 |

Table 2. Support Equipment

6. Ports and Cabling Information

| Ref ID | Port name on the EUT | Cable Description | Qty. | Length (m) | Shielded? (Y/N) | Termination Box ID & Port ID |
|--------|----------------------|-------------------|------|------------|-----------------|------------------------------|
| #4 | Power | 2 wire | 1 | 2 | N | DC Power Supply |

Table 3. Ports and Cabling Information

7. Method of Monitoring EUT Operation

A test receiver will be used to monitor the data transmission from the EUT.

8. Mode of Operation

The EUT will be configured to transmit at maximum power level. Test mode was provided to select the lower, middle and upper band of the transmitter by customer provided software. This software programmed the transmitter from three frequencies modulated and the other three in CW mode. These settings were created for testing purpose only.

9. Modifications

9.1 Modifications to EUT

No modifications were made to the EUT

9.2 Modifications to Test Standard

No Modifications were made to the test standard.

10. Disposition of EUT

The test sample including all support equipment submitted to H.B Compliance Solutions for testing will be returned to Raveon Technologies Corporation upon completion of testing & certification

Criteria for Intentional Radiators

1. RF Power Output

| | | | |
|-----------------------------|---------------------|--------------------------|------------|
| Test Requirement(s): | §2.1046 and §90.215 | Test Engineer(s): | Keith T. |
| Test Results: | Pass | Test Date(s): | 05/25/2018 |

Test Procedures: As required by 47 CFR 2.1046, RF Power output measurements were made at the RF output terminals of the EUT.

Customer provided a test mode internal to the EUT to control the RF modulation, and frequency channel. The EUT was connected through an attenuator to a Spectrum Analyzer capable of making power measurements. Measurements were made at the low, mid, and high channels of the entire frequency band.

| Frequency (MHz) | Conducted Power (dBm) | Conducted Power (W) |
|-----------------|-----------------------|---------------------|
| 151 | 36.97 | 5.0 |
| 162 | 36.74 | 4.72 |
| 172 | 36.89 | 4.88 |

Table 4. RF Power Output, Test Results

Test Setup:

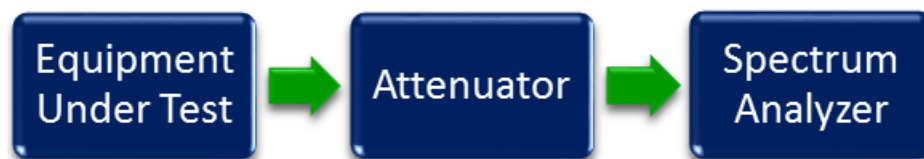
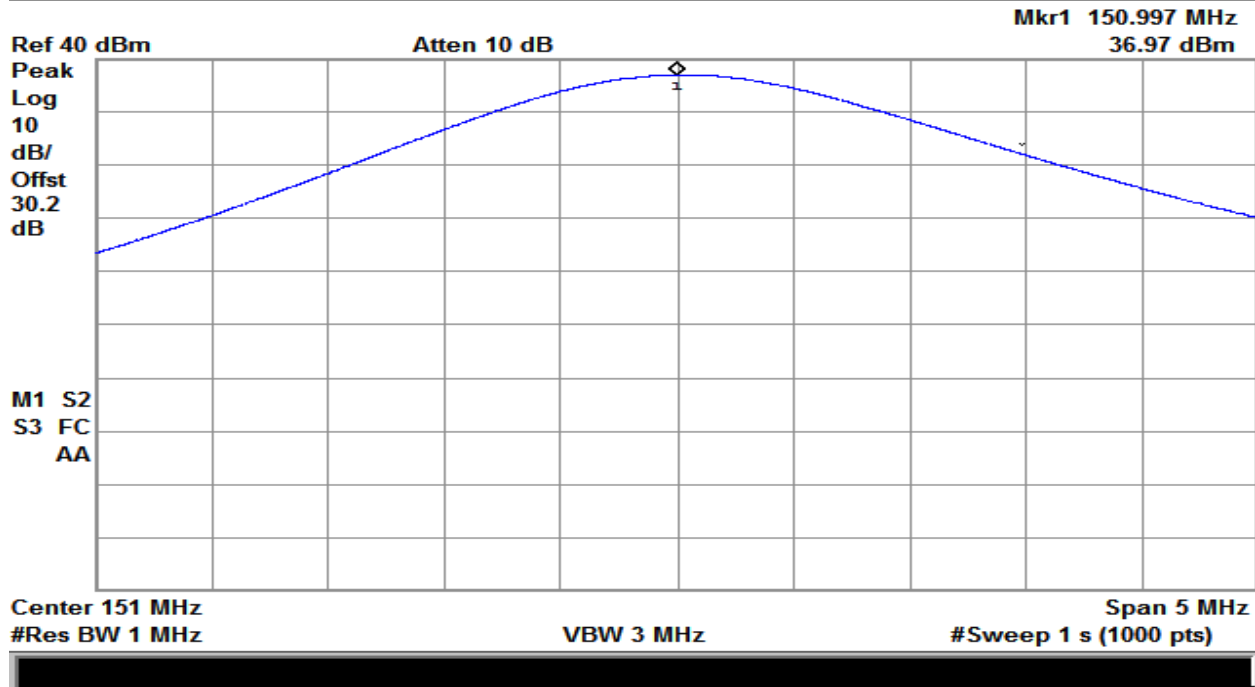
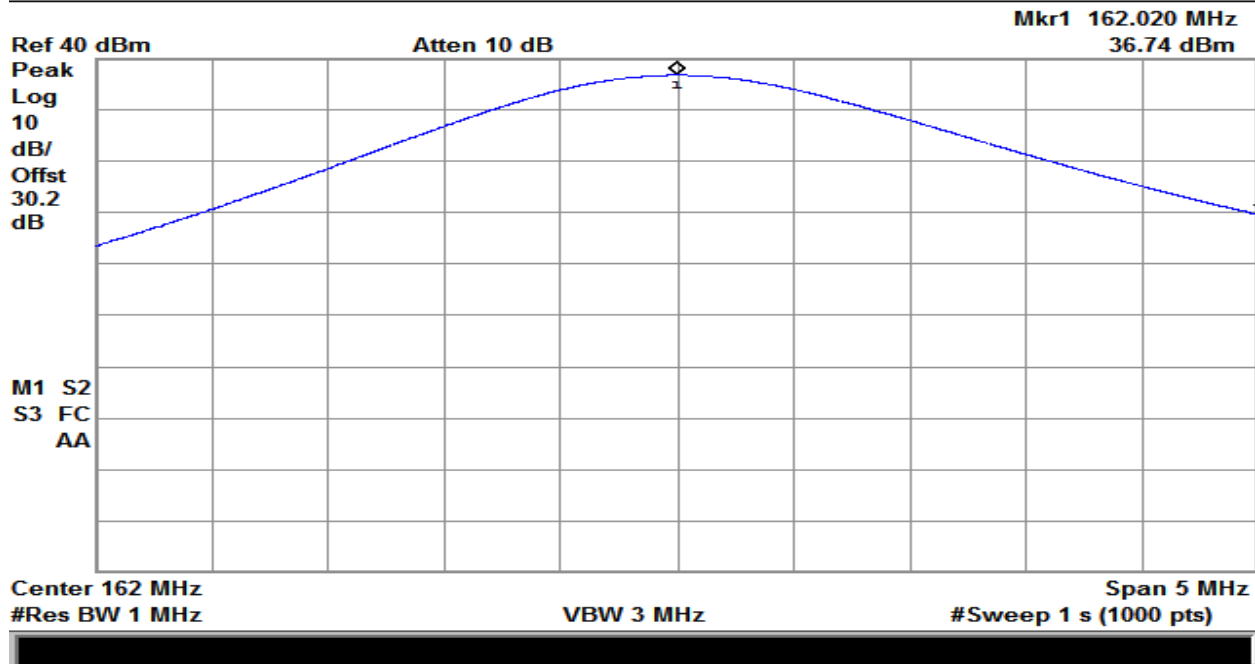


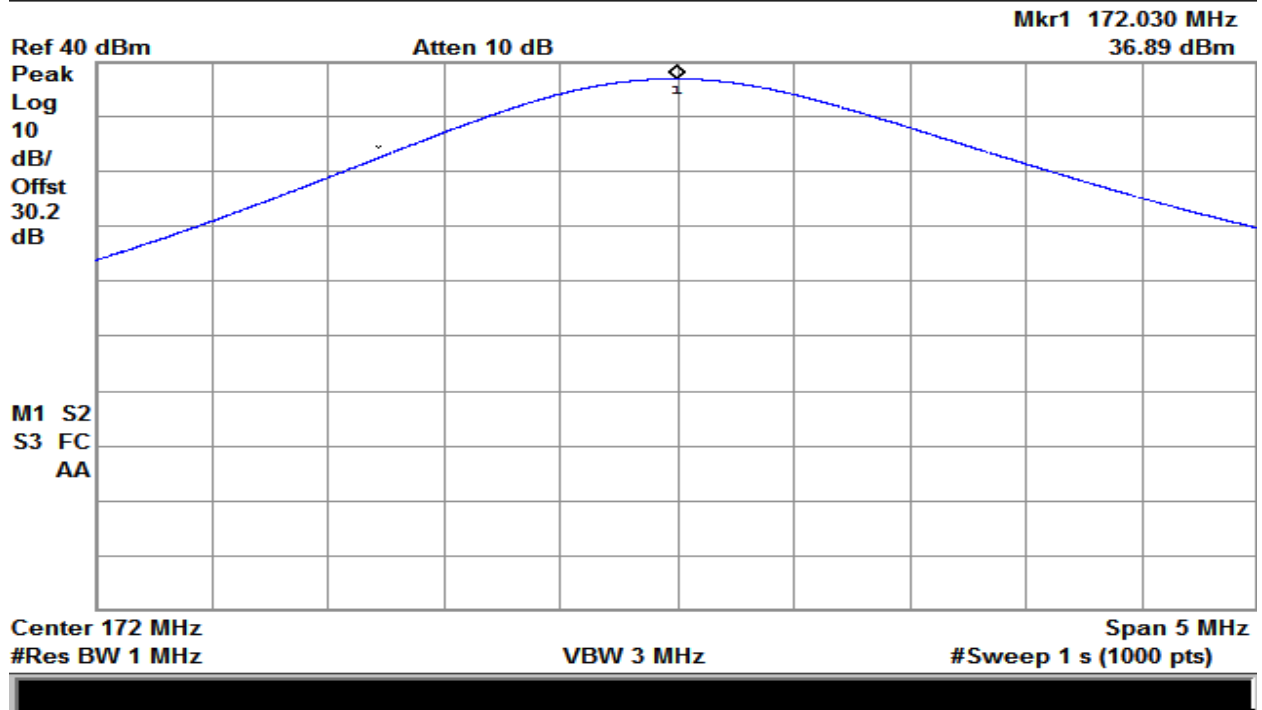
Figure 1 Output RF power Test Setup



Plot 1 – Output Power – Low



Plot 2 – Output Power – Mid



Plot 3 – Output Power – High

2. Modulation Characteristics

| | | | |
|-----------------------------|--------------------|--------------------------|------------|
| Test Requirement(s): | 2.1047 and §90.207 | Test Engineer(s): | Keith T. |
| Test Results: | Pass | Test Date(s): | 05/23/2018 |

Test Procedure: As required by 47 CFR 2.1047, Modulation characteristics measurements were made at the RF output terminals of the EUT.

Customer provided a test mode internal to the EUT to control the RF modulation, and frequency channel. The EUT was connected through an attenuator to a Spectrum Analyzer.

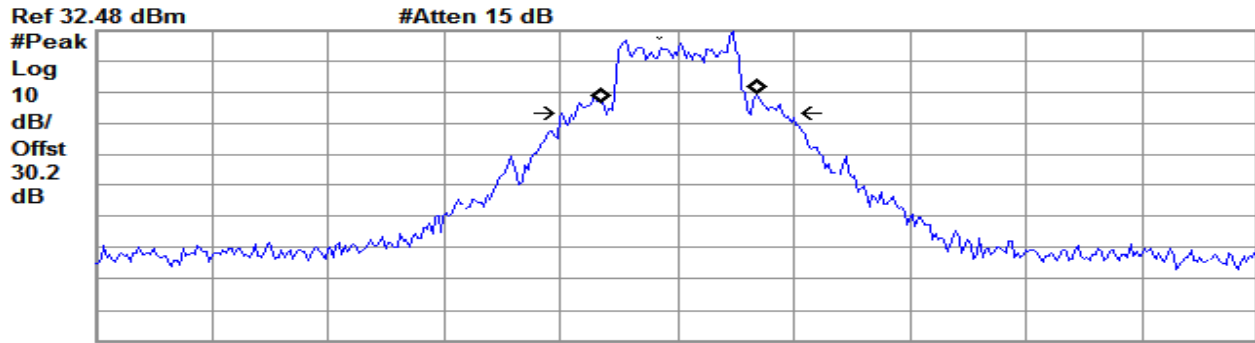
As per standard a curve or equivalent data of the EUT is shown

The plot(s) of the modulation characteristic is presented hereinafter as reference.

Test Setup:



Figure 2: Modulation Characteristics Bandwidth Test Setup

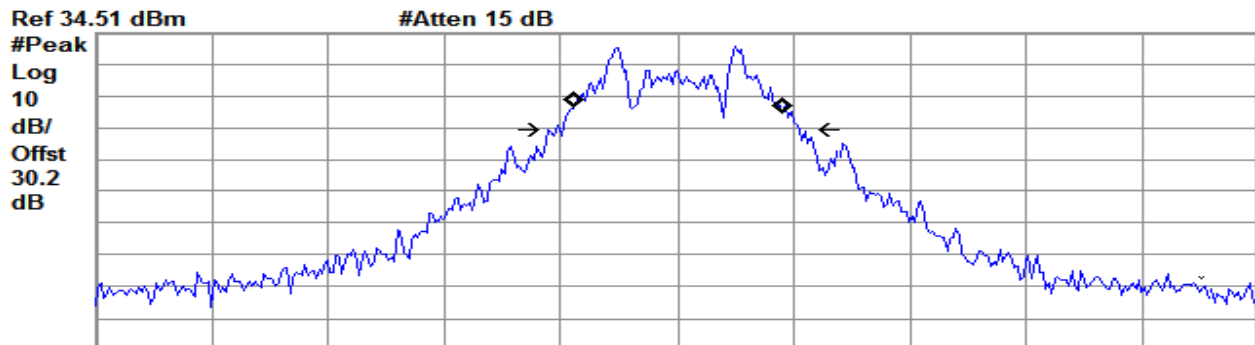


Center 151 MHz Span 50 kHz
 #Res BW 100 Hz VBW 300 Hz Sweep 2.86 s (401 pts)

Occupied Bandwidth Occ BW % Pwr 99.00 %
 6.6185 kHz x dB -26.00 dB

Transmit Freq Error 61.493 Hz
 x dB Bandwidth 8.809 kHz

Plot 4 – Narrow Band



Center 172 MHz Span 50 kHz
 #Res BW 100 Hz VBW 300 Hz Sweep 2.86 s (401 pts)

Occupied Bandwidth Occ BW % Pwr 99.00 %
 8.8789 kHz x dB -26.00 dB

Transmit Freq Error 101.486 Hz
 x dB Bandwidth 10.450 kHz

Plot 5 – Wide Band

3. Occupied Bandwidth (Emission Mask)

| | | | |
|-----------------------------|---------------------------------------------------|--------------------------|------------|
| Test Requirement(s): | 2.1049 and §90.210 with FCC (Emission Mask C & D) | Test Engineer(s): | Keith T. |
| Test Results: | Pass | Test Date(s): | 05/23/2018 |

Test Procedure: As required by 47 CFR 2.1049, occupied bandwidth measurements were made at the output terminals of the EUT.

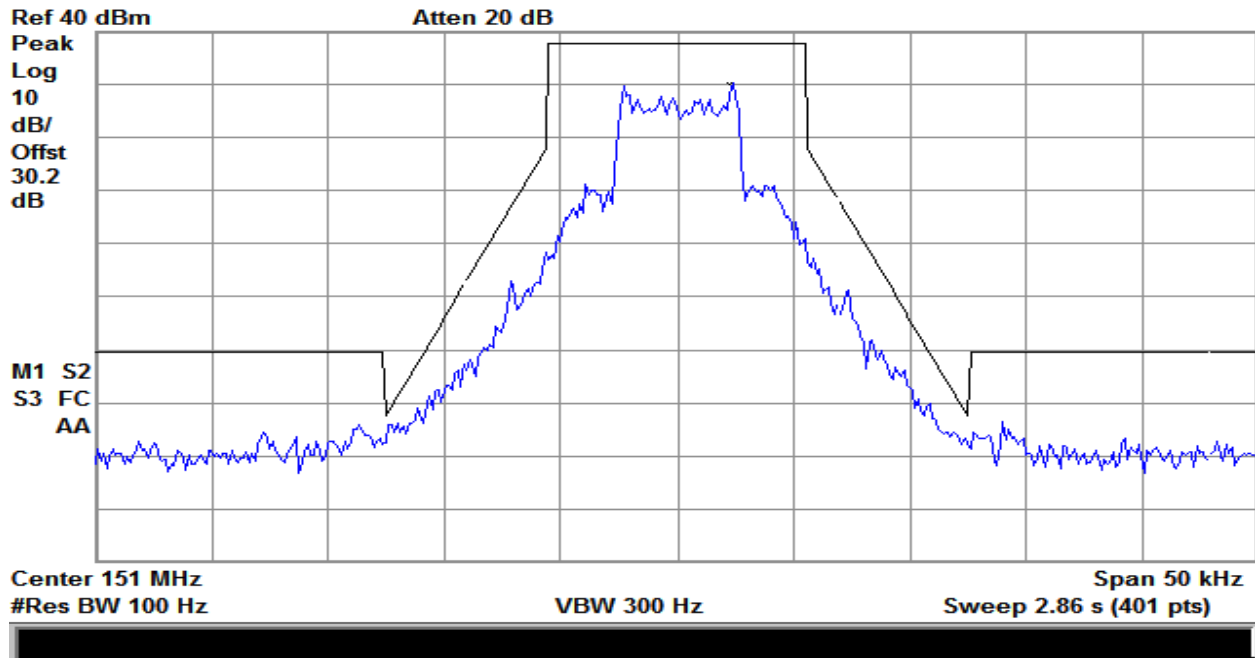
Customer provided a test mode internal to the EUT to control the RF modulation, and frequency channel. The EUT was connected through an attenuator to a Spectrum Analyzer. The measured highest peak power was set relative to zero dB reference. The RBW of the Spectrum Analyzer was set to at least 1% of the channel bandwidth. Measurements were carried out at the low, mid and high channels of the TX band.

Test Setup:

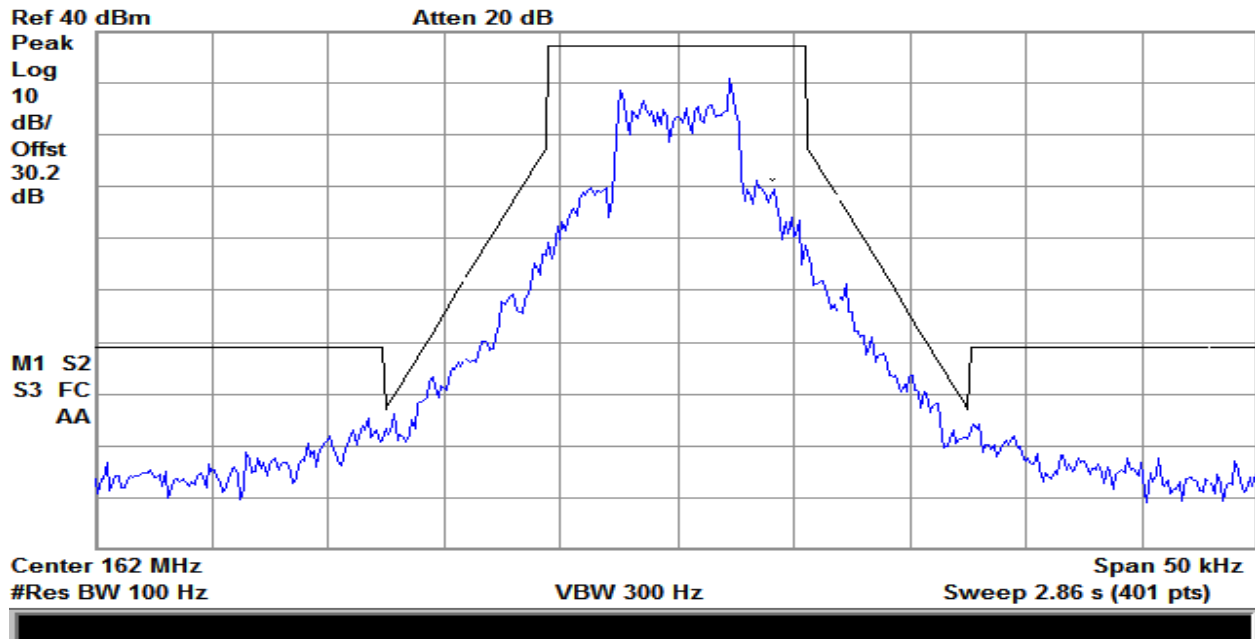


Figure 3: Occupied Bandwidth Test Setup

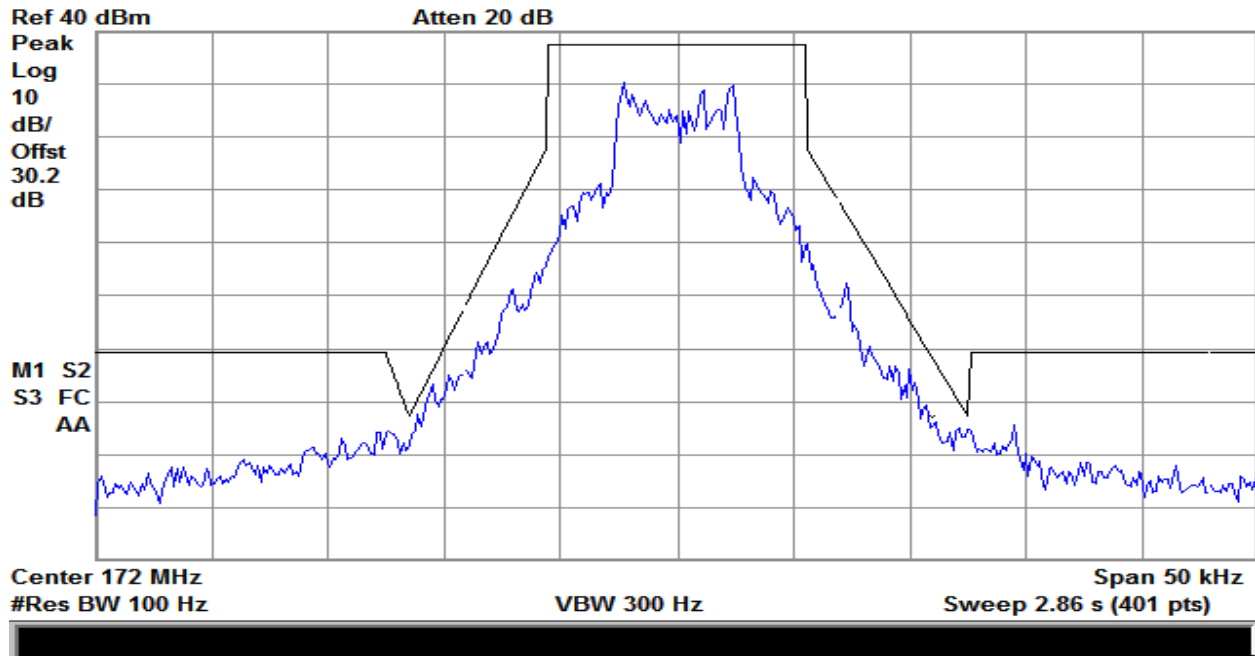
The following pages show measurements of Emission Mask plots:



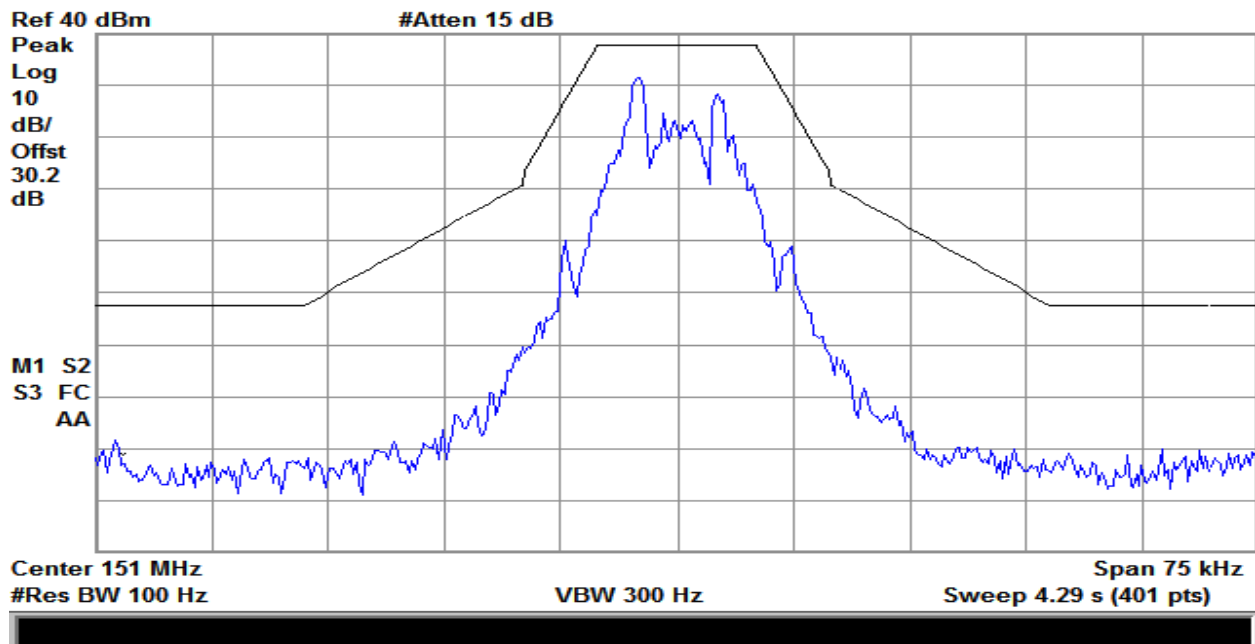
Plot 6 – Low Chanel at Narrow Band 12.5 kHz Spacing – Mask D



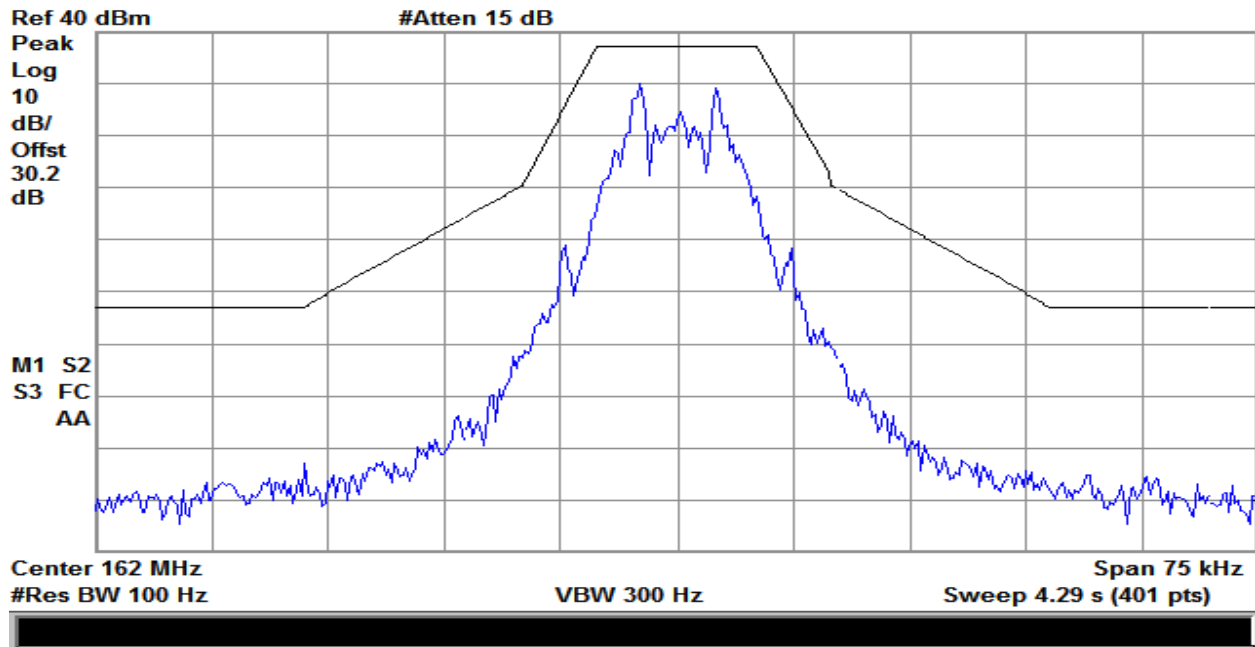
Plot 7 – Mid Chanel at Narrow Band 12.5 kHz Spacing – Mask D



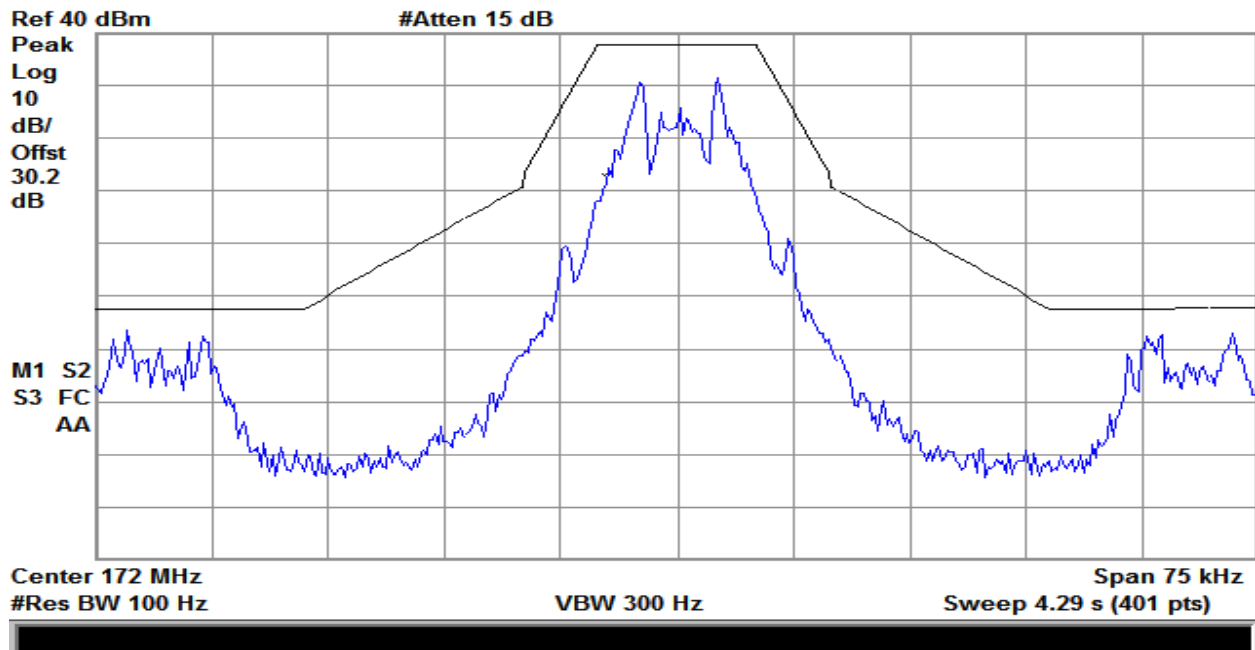
Plot 8 – High Channel at Narrow Band 12.5 kHz Spacing – Mask D



Plot 9 – Low Channel at Wideband Band 25 kHz Spacing – Mask C



Plot 10 – Mid Chanel at Wideband Band 25 kHz Spacing – Mask C



Plot 11 – High Chanel at Wideband Band 25 kHz Spacing – Mask C

4. Spurious Emissions at Antenna Terminals

| | | | |
|-----------------------------|-----------------------|--------------------------|------------|
| Test Requirement(s): | §2.1051 and 90.210(m) | Test Engineer(s): | Keith T. |
| Test Results: | Pass | Test Date(s): | 05/25/2018 |

Test Procedures:

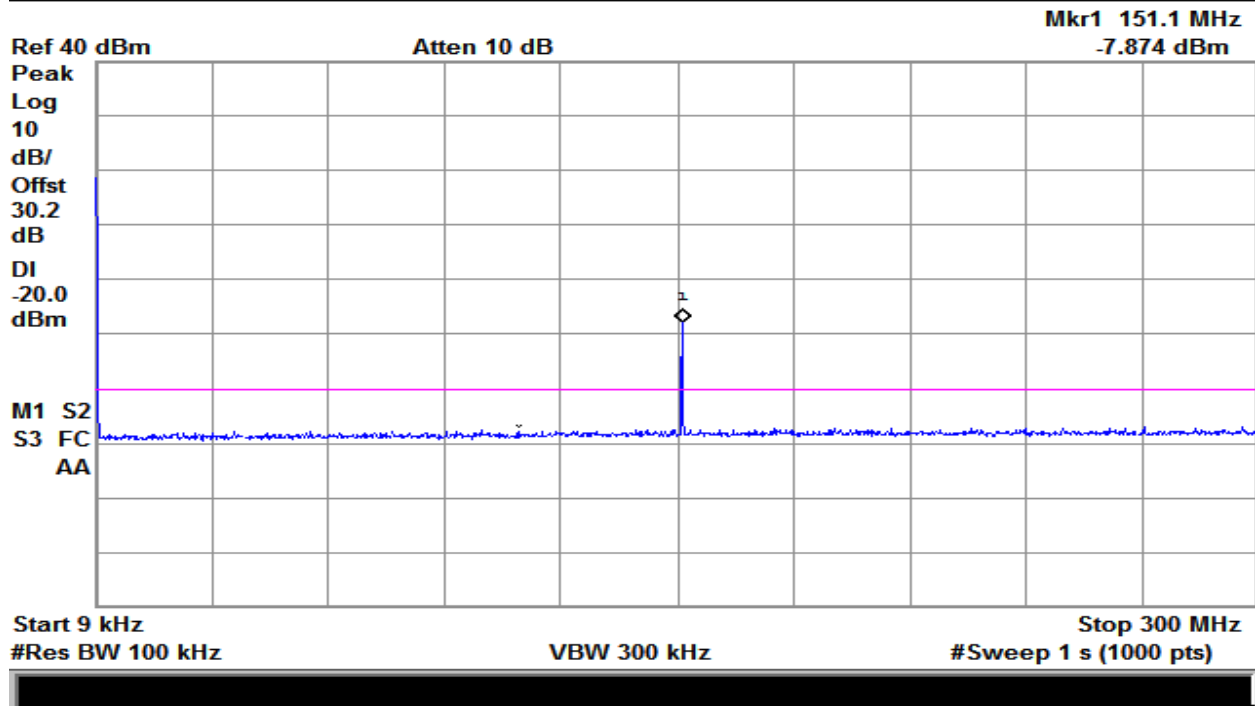
As required by 47 CFR 2.1051, spurious emissions at antenna terminal measurements were made at the RF output antenna terminal of the EUT.

Customer provided a test mode internal to the EUT to control the RF modulation, and frequency channel. The EUT was connected through an attenuator to a Spectrum Analyzer. The Spectrum Analyzer was set to sweep from 30MHz up to 10th harmonic of the fundamental or 40GHz whichever is the lesser. Measurements were made at the low, mid and high frequency of the transmit band.

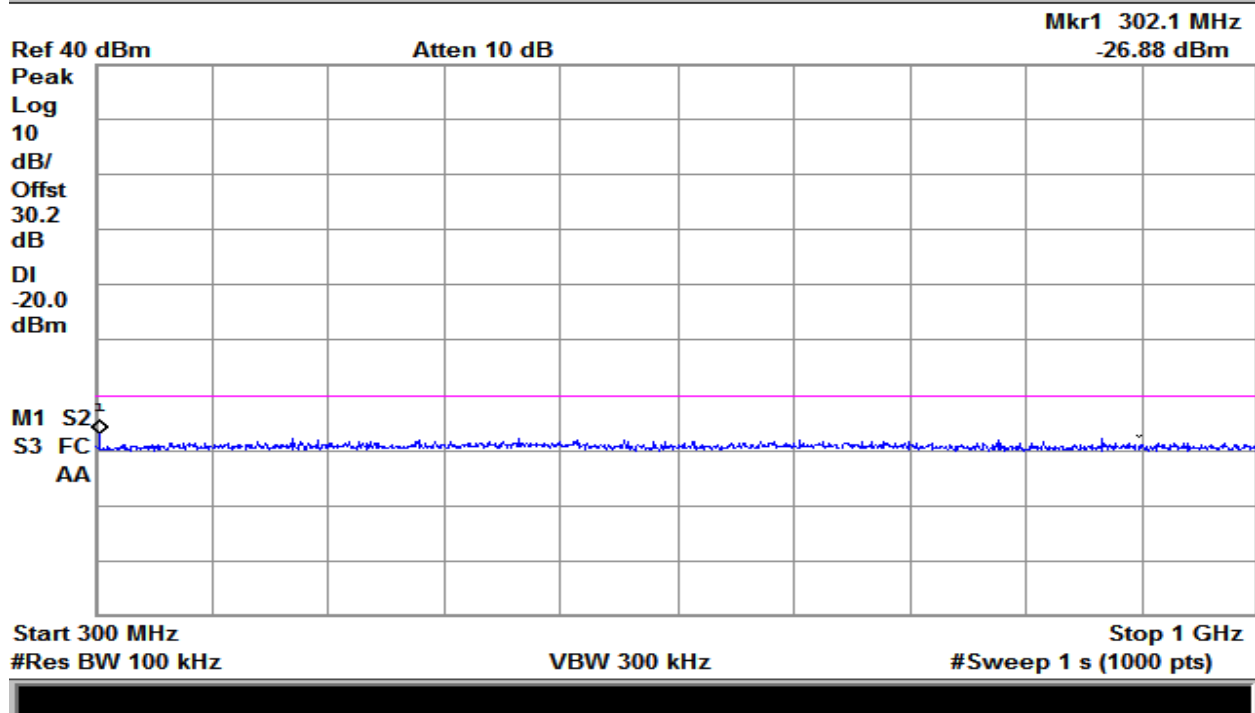
Test Setup:



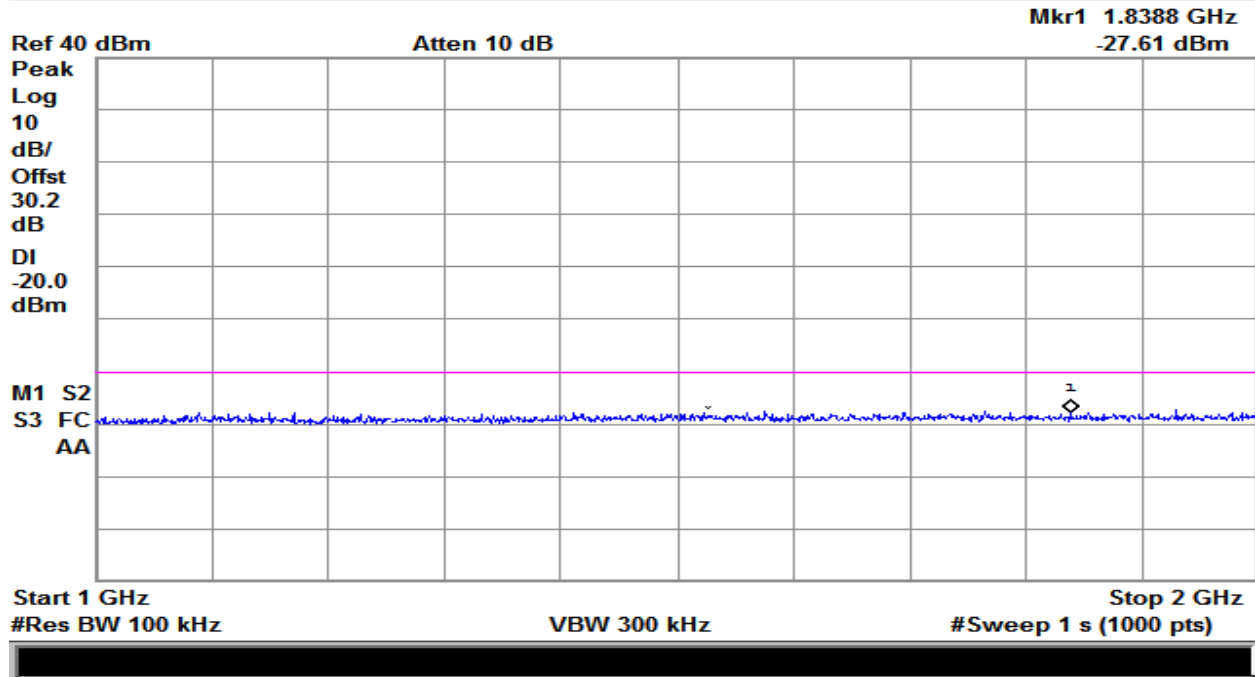
Figure 4: Spurious Emission at Antenna Terminal Test setup



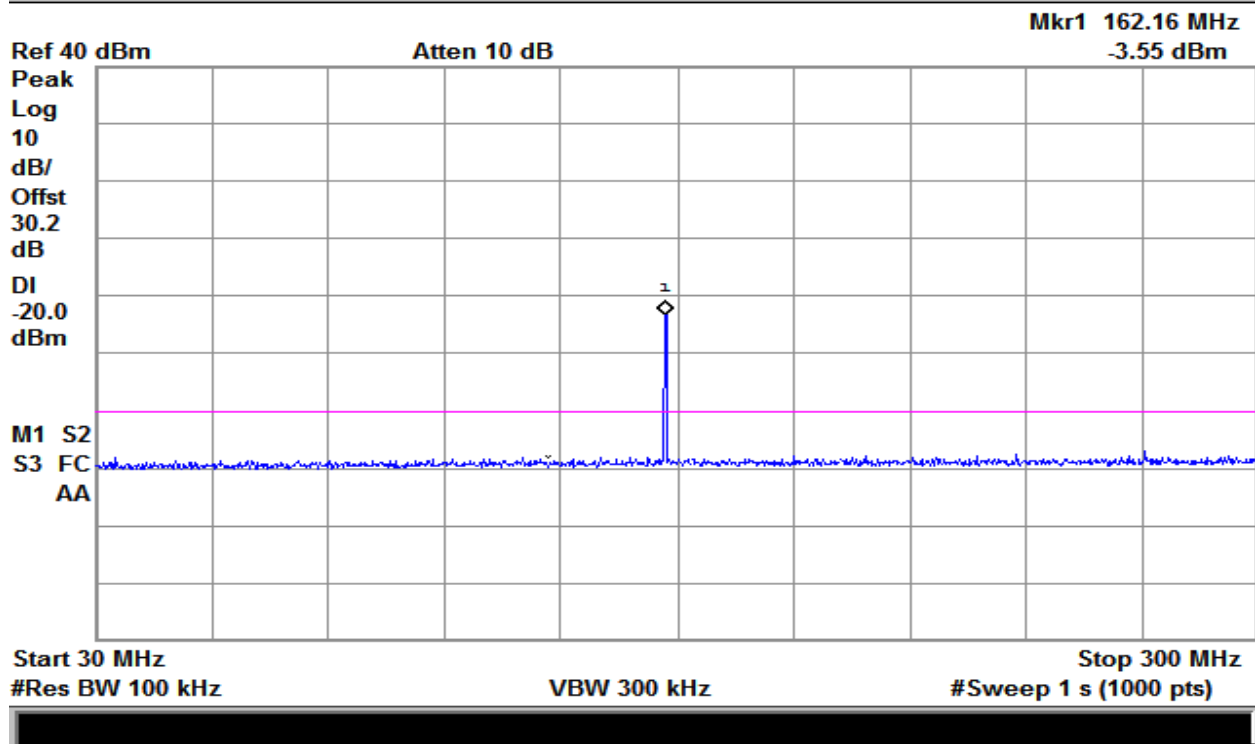
Plot 12 – Low Band



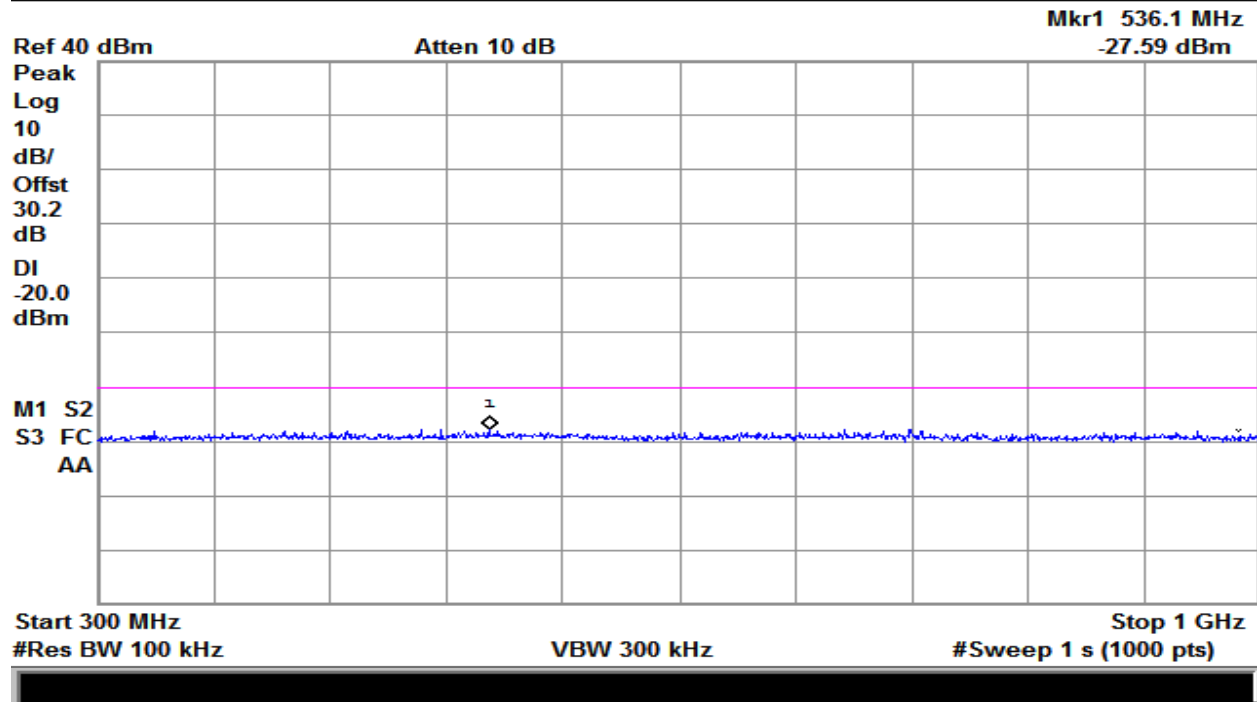
Plot 13 – Low Band



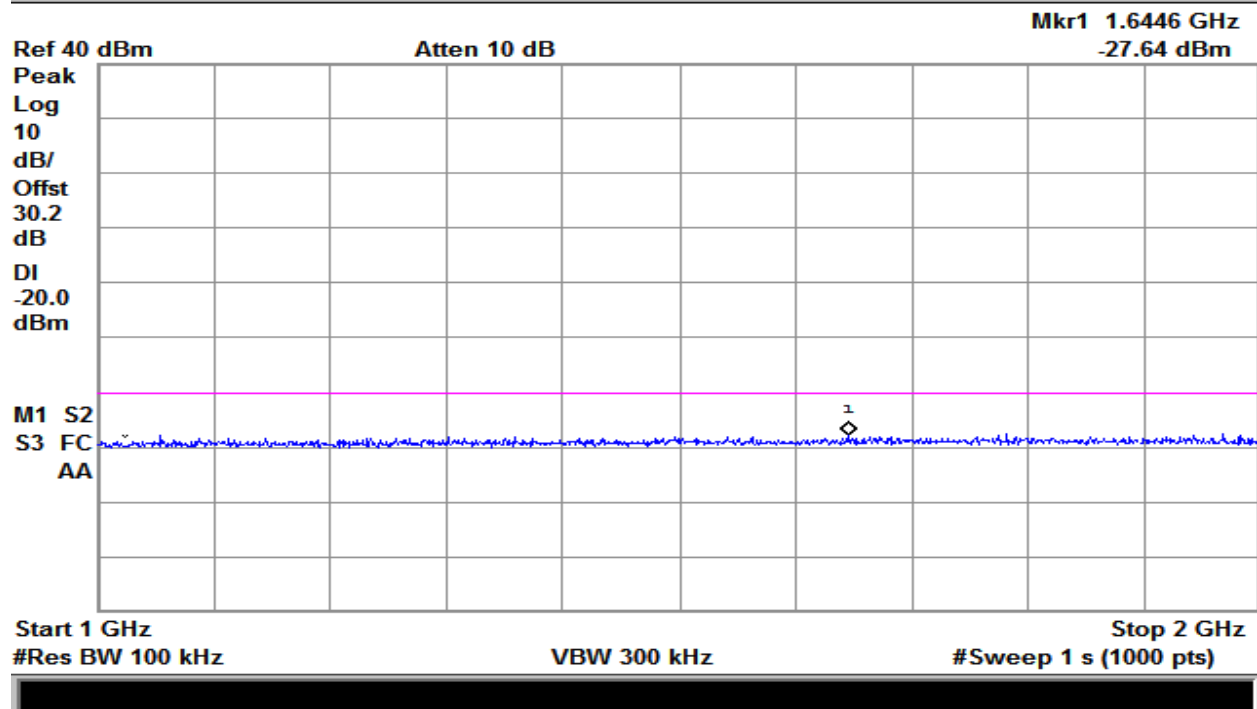
Plot 14 – Low Band



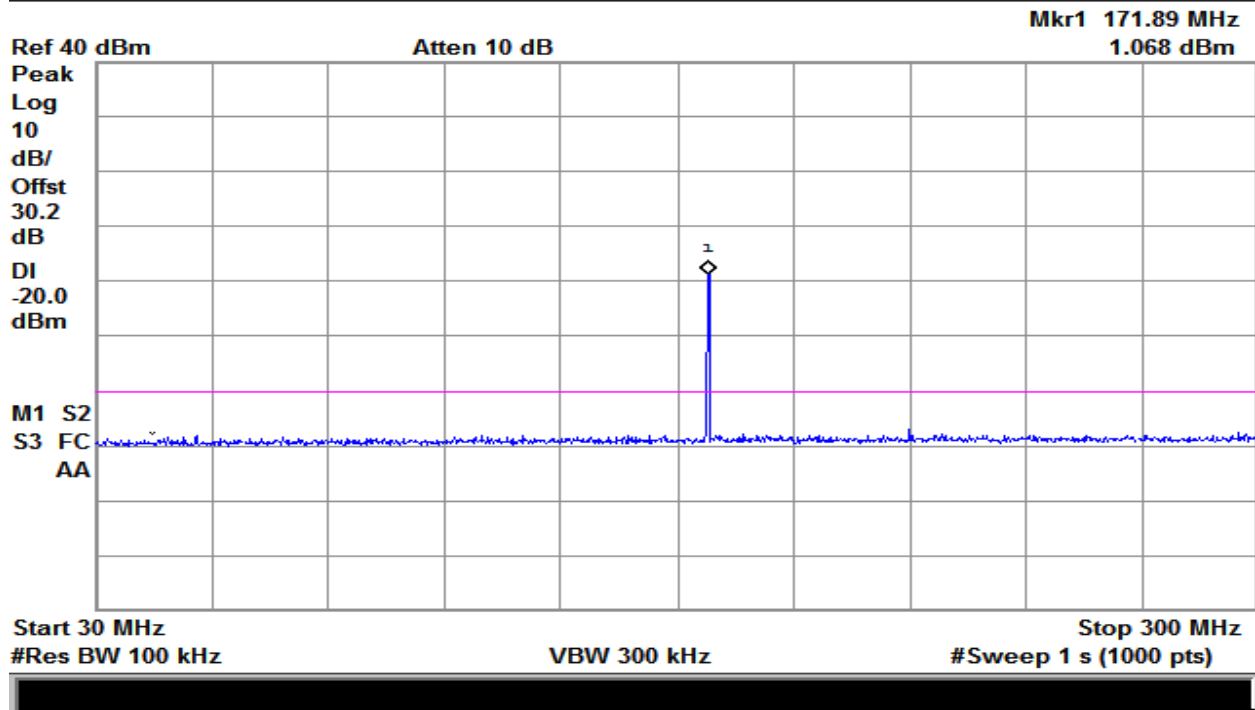
Plot 15 – Mid Band



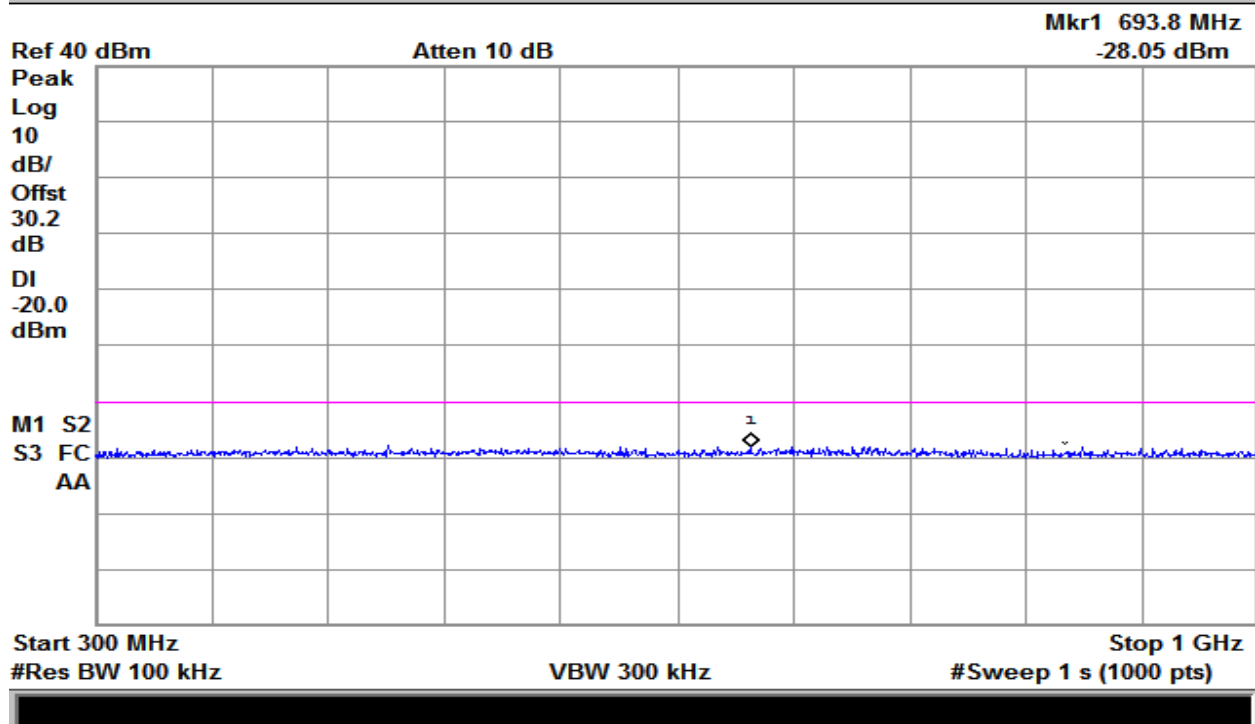
Plot 16 – Mid Band



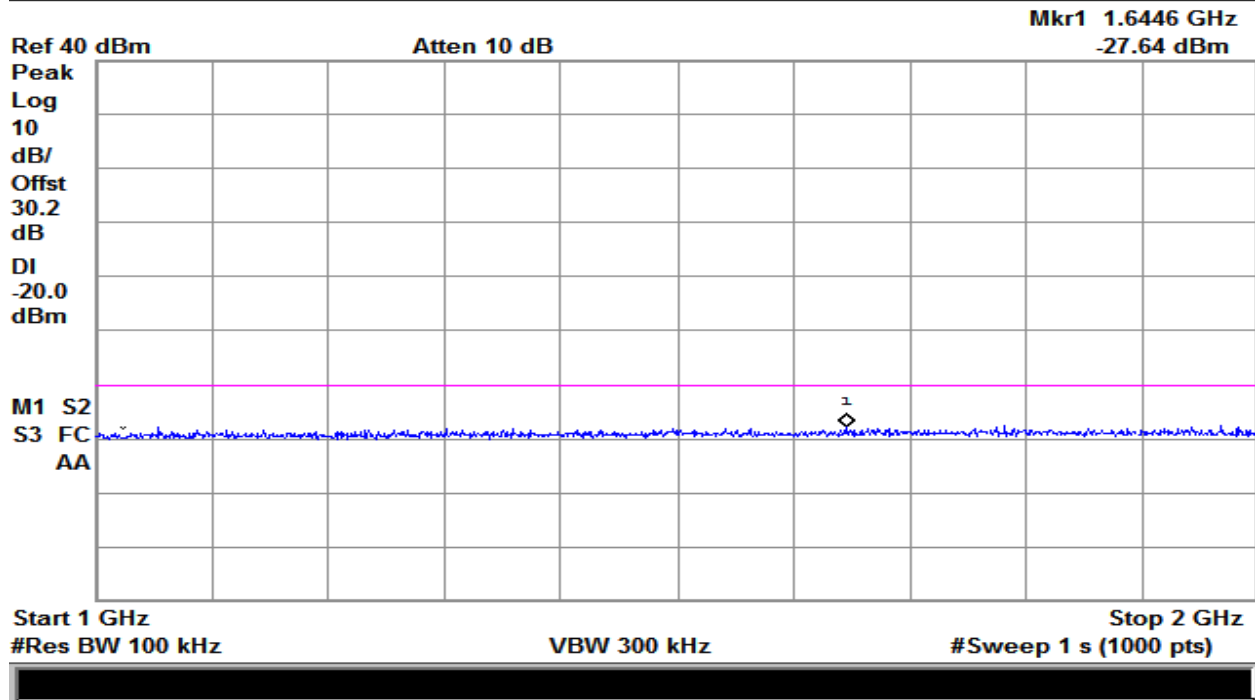
Plot 17 – Mid Band



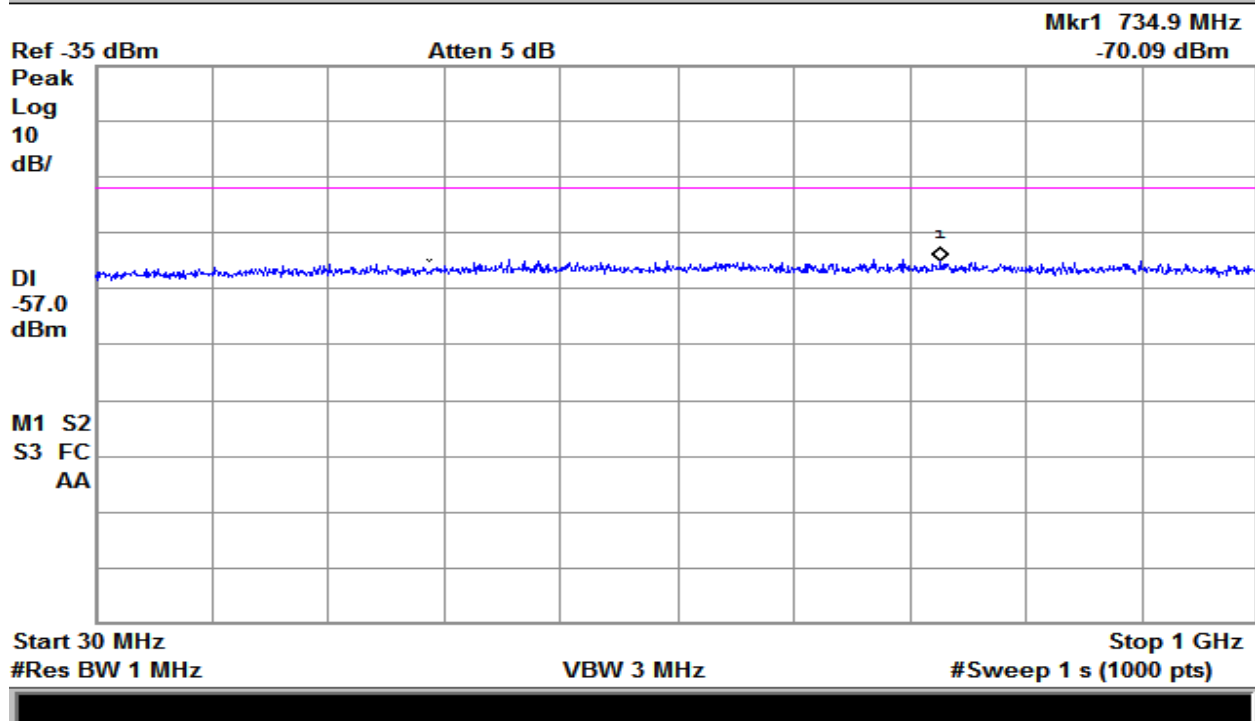
Plot 18 – High Band



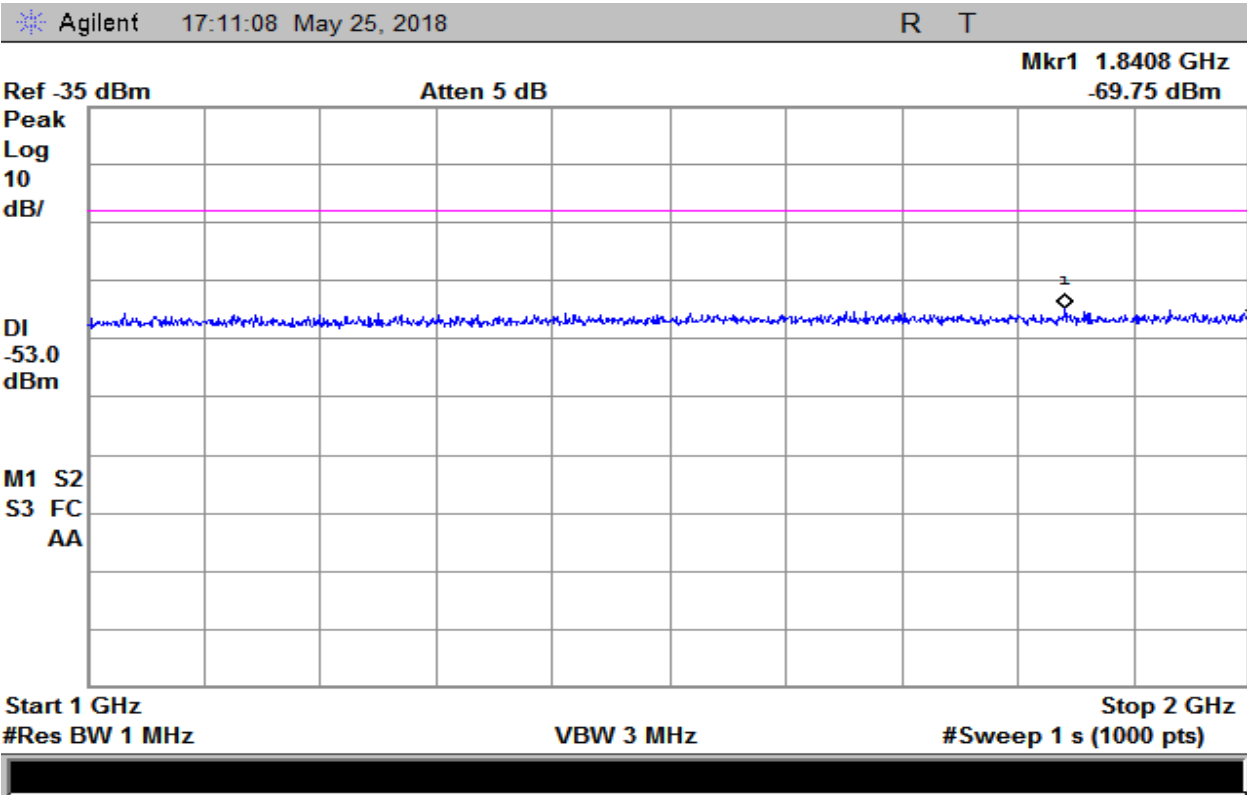
Plot 19 – High Band



Plot 20 – High Band



Plot 21 – Receiver Emission – For Industry Canada Only (RSS-GEN)



Plot 22 – Receiver Emission – For Industry Canada Only (RSS-GEN)

5. Radiated Spurious Emissions

| | | | |
|-----------------------------|-----------------------|--------------------------|------------|
| Test Requirement(s): | §2.1053 and 90.210(j) | Test Engineer(s): | Keith T. |
| Test Results: | Pass | Test Date(s): | 06/19/2018 |

Test Procedures: As required by 47 CFR 2.1053, field strength of radiated spurious measurements were made in accordance with the procedures of the TIA/EIA-603-D-2010.

The EUT was placed on a wooden table inside a 3 meter semi-anechoic chamber. The EUT was transmitting into a non-radiating load which was directly connected to the EUT antenna port.

The measurement antenna was placed at a distance of 3 meters from the EUT. During the tests, the antenna height and polarization as well as EUT azimuth were varied in order to identify the maximum level of emissions from the EUT. The test was performed by placing the EUT on 3 orthogonal axis. The frequency range up to the 10th harmonic was investigated.

The EUT is removed and replaced with a substitution antenna. A signal generator was connected to the substitution antenna by a non-radiating cable. The absolute levels of the spurious emissions were measured by the substitution.

Spurious emissions in dB = $10 \log (T_{pwr} \text{ in Watts}/0.001)$ -the absolute level

Spurious attenuation limit in dB = $50 + 10 \log_{10} (P)$ dB or 70dB whichever is the lesser attenuation

Test Setup:

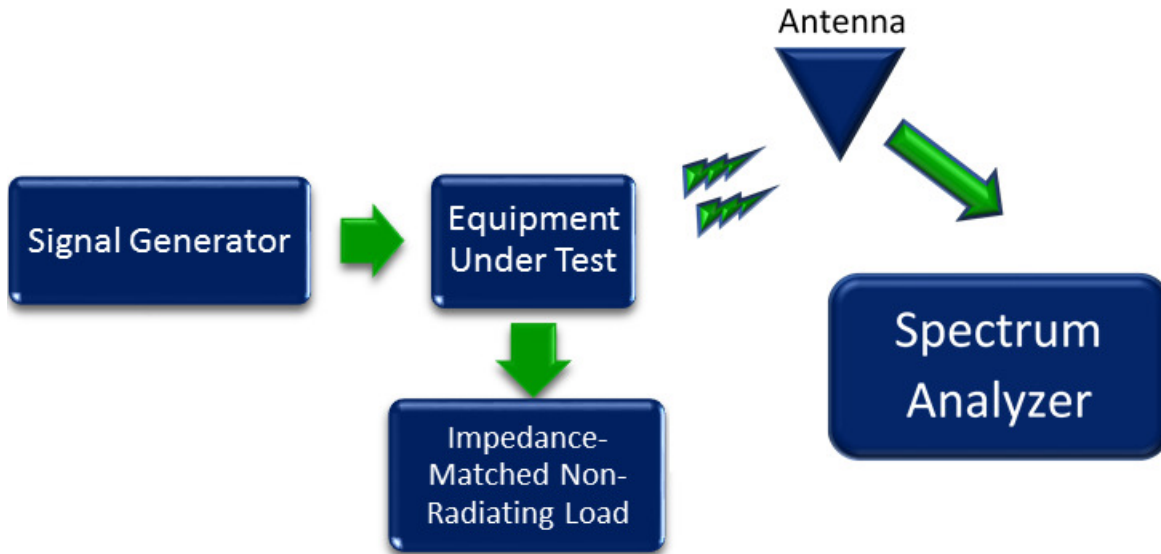


Figure 5 – Radiated Spurious Emissions

| Frequency (MHZ) | Amplitude (dbuV) | Antenna Polarity | Cable Loss | Substitution Generator Level (dbm) | Transmit Antenna Gain | Corrected Amplitude (dBm) | Limit (dBm) |
|-----------------|------------------|------------------|------------|------------------------------------|-----------------------|---------------------------|-------------|
| 304 | 30.3 | Vert | 0.3 | -62 | 6.6 | -55.4 | -20 |
| 456 | 29.3 | Vert | 0.35 | -58 | 6.5 | -51.5 | -20 |
| 608 | 37.3 | Vert | 0.45 | -48.0 | 7.2 | -40.8 | -20 |
| 760 | 41.9 | Vert | 0.8 | -42 | 7.1 | -34.9 | -20 |

Table 5 - Spurious Radiated Emission Data – Low Band

| Frequency | Amplitude (dbuV) | Antenna Polarity | Cable Loss | Substitution Generator Level (dbm) | Transmit Antenna Gain | Corrected Amplitude (dBm) | Limit (dBm) |
|-----------|------------------|------------------|------------|------------------------------------|-----------------------|---------------------------|-------------|
| 324 | 30.5 | Vert | 0.3 | -59 | 6.6 | -52.4 | -20 |
| 486 | 31.6 | Vert | 0.35 | -58 | 6.5 | -51.5 | -20 |
| 648 | 35.8 | Vert | 0.45 | -50 | 7.3 | -42.7 | -20 |
| 810 | 32 | Vert | 0.8 | -53 | 7.6 | -45.4 | -20 |

Table 6 – Spurious Radiated Emission Data – Mid Band

| Frequency | Amplitude (dbuV) | Antenna Polarity | Cable Loss | Substitution Generator Level (dbm) | Transmit Antenna Gain | Corrected Amplitude (dBm) | Limit (dBm) |
|-----------|------------------|------------------|------------|------------------------------------|-----------------------|---------------------------|-------------|
| 344 | 34.6 | Vert | 0.3 | -51 | 6.6 | -44.4 | -20 |
| 516 | 34.6 | Vert | 0.35 | -55 | 6.5 | -48.5 | -20 |
| 688 | 35.6 | Vert | 0.45 | -48 | 7.3 | -40.7 | -20 |
| 860 | 30.6 | Vert | 0.8 | -58 | 7.6 | -50.4 | -20 |

Table 7 – Spurious Radiated Emission Data – High Band

6. Frequency Stability vs Temperature

| | | | |
|-----------------------------|--------------------|--------------------------|------------|
| Test Requirement(s): | §2.1055 and 90.213 | Test Engineer(s): | Jerry M. |
| Test Results: | Pass | Test Date(s): | 04/23/2018 |

Test Procedures: As required by 47 CFR 2.0155, Frequency Stability measurements were made at the RF antenna output terminals of the EUT.

The EUT was placed in an Environmental Chamber with all the support equipment outside the chamber. The EUT was set to transmit a modulated carrier. The reference frequency at 20°C was observed and noted down. The frequency drift was investigated for every 10°C increment until the unit was stabilized then recorded the reading in tabular format with the temperature range of -30°C to 50°C.

Test Setup:

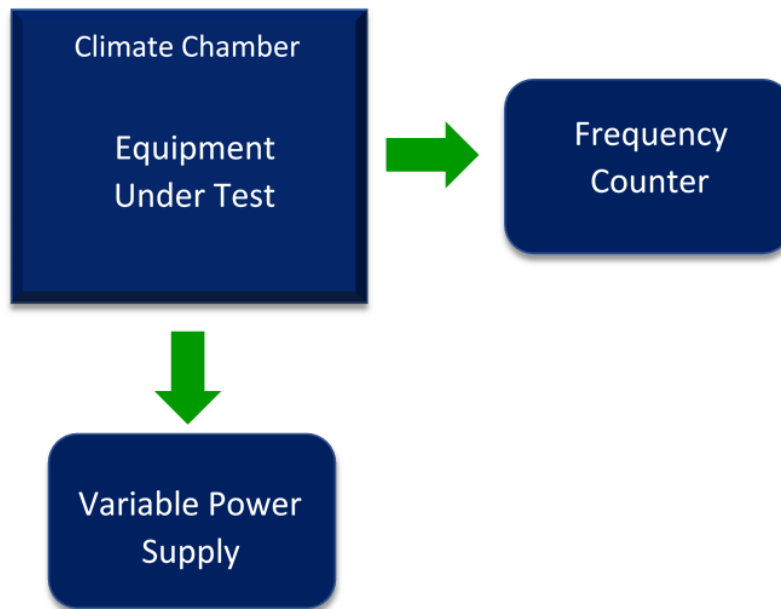
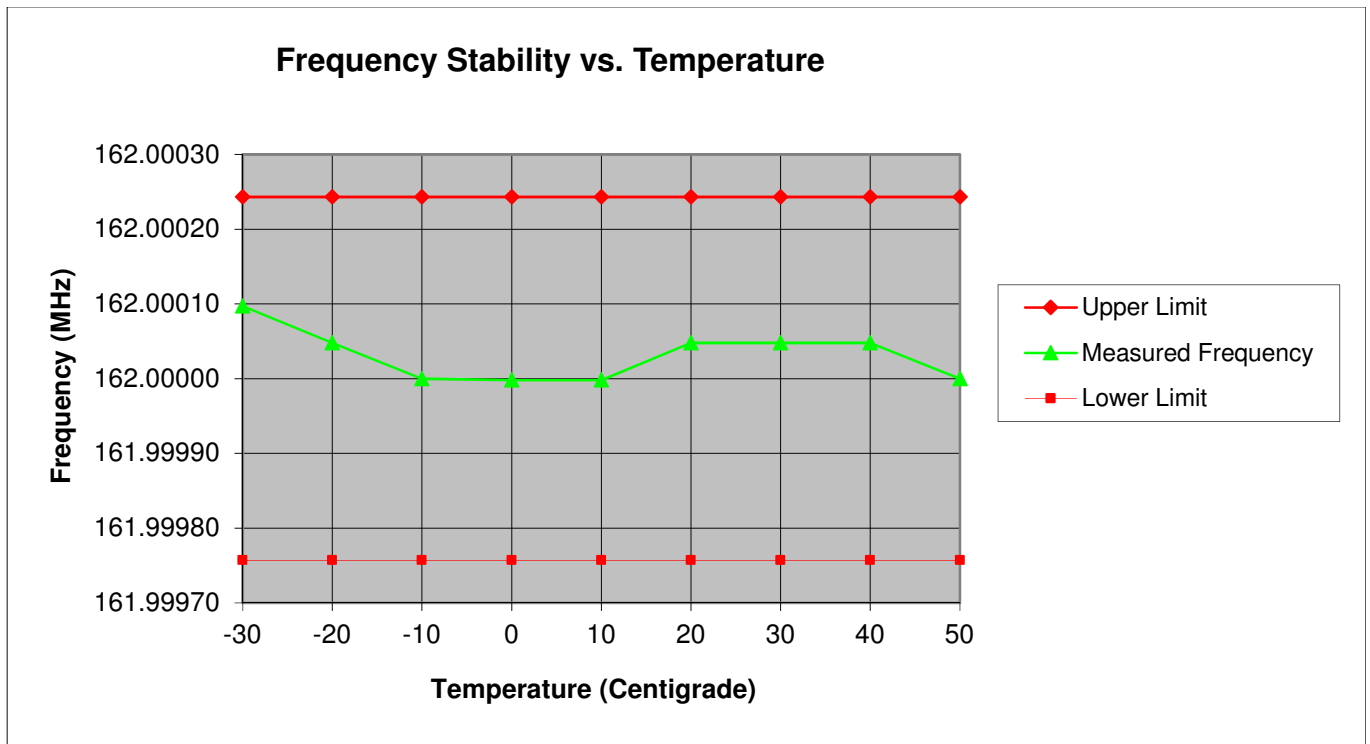


Figure 6 – Frequency Stability Test Setup

| Temperature centigrade | Measured Frequency (MHz) | Upper Margin (MHz) | Lower Margin (MHz) |
|------------------------|--------------------------|--------------------|--------------------|
| -30 | 162.000097 | -0.00015 | 0.00034 |
| -20 | 162.000048 | -0.00020 | 0.00029 |
| -10 | 162.000000 | -0.00024 | 0.00024 |
| 0 | 161.999998 | -0.00025 | 0.00024 |
| 10 | 161.999998 | -0.00025 | 0.00024 |
| 20 | 162.000048 | -0.00020 | 0.00029 |
| 30 | 162.000048 | -0.00020 | 0.00029 |
| 40 | 162.000048 | -0.00020 | 0.00029 |
| 50 | 162.000000 | -0.00024 | 0.00024 |

Table 8 – Temperature vs Frequency Test Result



Plot 23 – Temperature vs Frequency

7. Frequency Stability vs Voltage

| | | | |
|-----------------------------|---------|--------------------------|-------------|
| Test Requirement(s): | §2.1055 | Test Engineer(s): | Jerry Mejak |
| Test Results: | Pass | Test Date(s): | 04/23/2018 |

Test Procedures: As required by 47 CFR 2.0155, Frequency Stability measurements were made at the RF antenna output terminals of the EUT.

The EUT was connected to a variable DC source. The frequency was measured at both the nominal 12 Vdc of the EUT and at the extreme lower and upper voltages.

With the voltage set to a measurement point, the transmitted signal was captured by the spectrum analyzer and the frequency value determined. The frequencies are compared to the tuned frequency. All data for these measurements are found in the table 9.

Reference Frequency: 460.6MHz at 12VdC at 20°C

Test Setup:

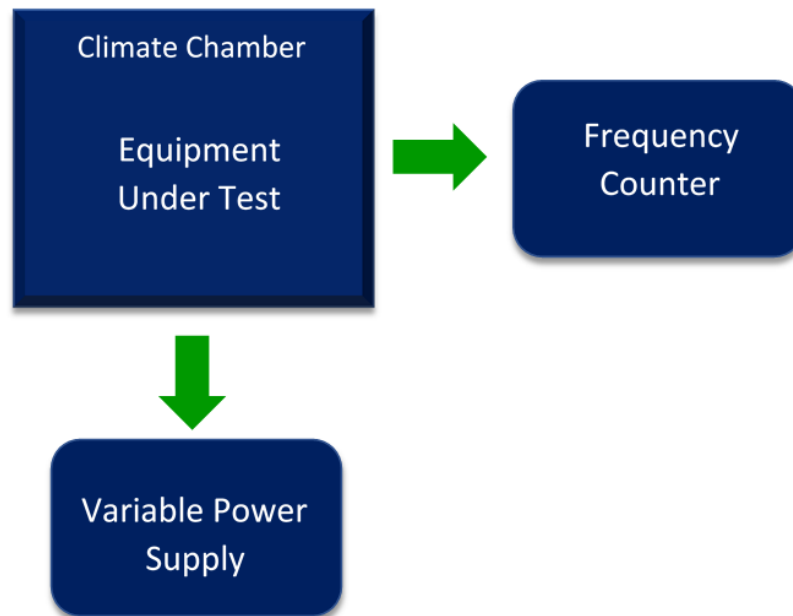
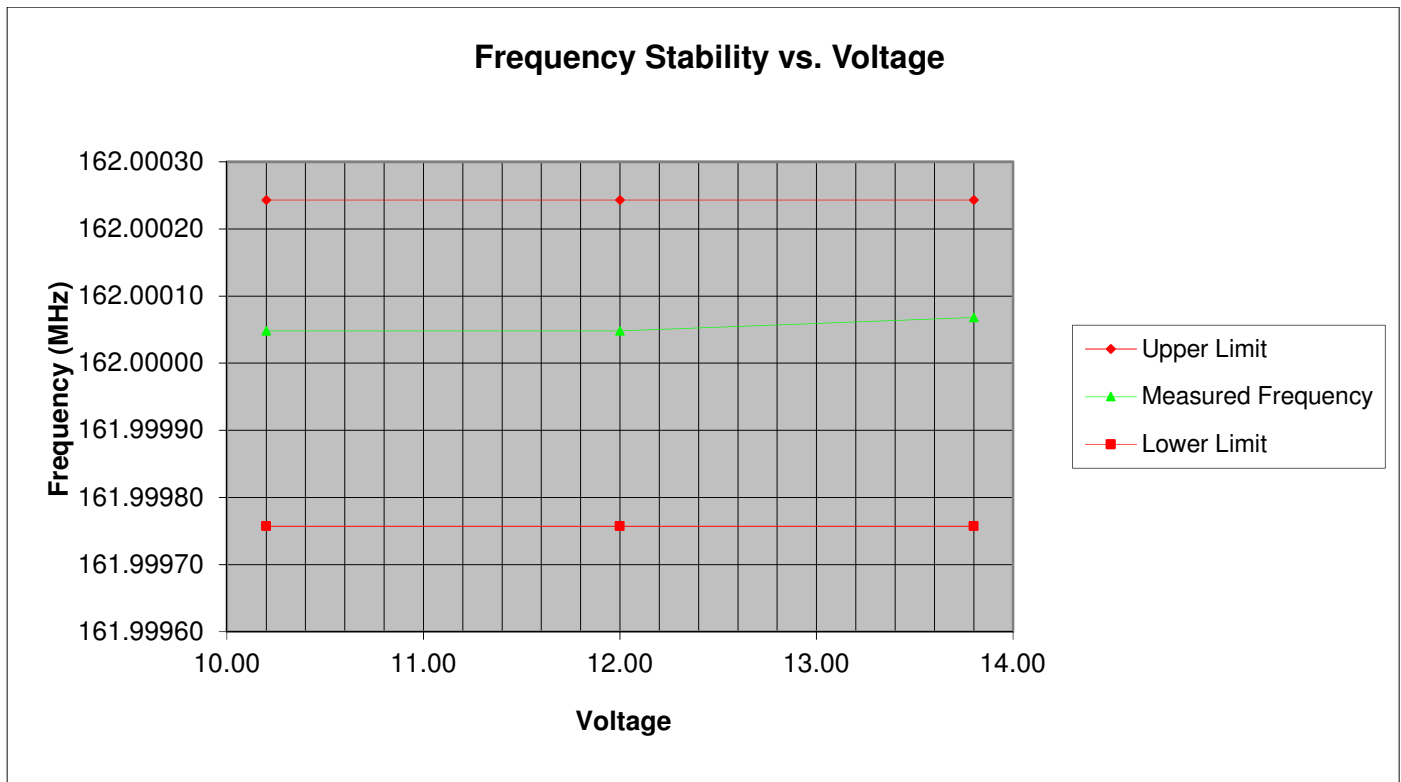


Figure 7 – Frequency Stability Test Setup

| Input Voltage (Vdc) | Measured Frequency (MHz) | Upper Margin (MHz) | Lower Margin (MHz) |
|---------------------|--------------------------|--------------------|--------------------|
| 10.20 | 162.000048 | -0.00020 | 0.00029 |
| 12.00 | 162.000048 | -0.00020 | 0.00029 |
| 13.80 | 162.000068 | -0.00018 | 0.00031 |

Table 9. Temperature vs. Voltage Test Result



Plot 24 – Temperature vs Voltage

8. Transient Frequency Behavior

| | | | |
|-----------------------------|---------|--------------------------|------------|
| Test Requirement(s): | §90.214 | Test Engineer(s): | Keith T. |
| Test Results: | Pass | Test Date(s): | 05/30/2018 |

Test Procedures: The EUT was tested for transient frequency behavior using the test method of TIA/EIA 603.

| RF Frequency | Channel Bandwidth | Transient Period | Transient Behavior | Result |
|--------------|-------------------|------------------|--------------------|--------|
| 162MHz | 12.5KHz | t1= 10ms | <±12.5kHz | Pass |
| | | t2= 25ms | <±6.25kHz | Pass |
| | | t3= 10ms | <±12.5kHz | Pass |

Table 7. Transient Frequency – Test Requirement

The following pages show measurements of Transient Frequency Behavior plots:

Test Setup:

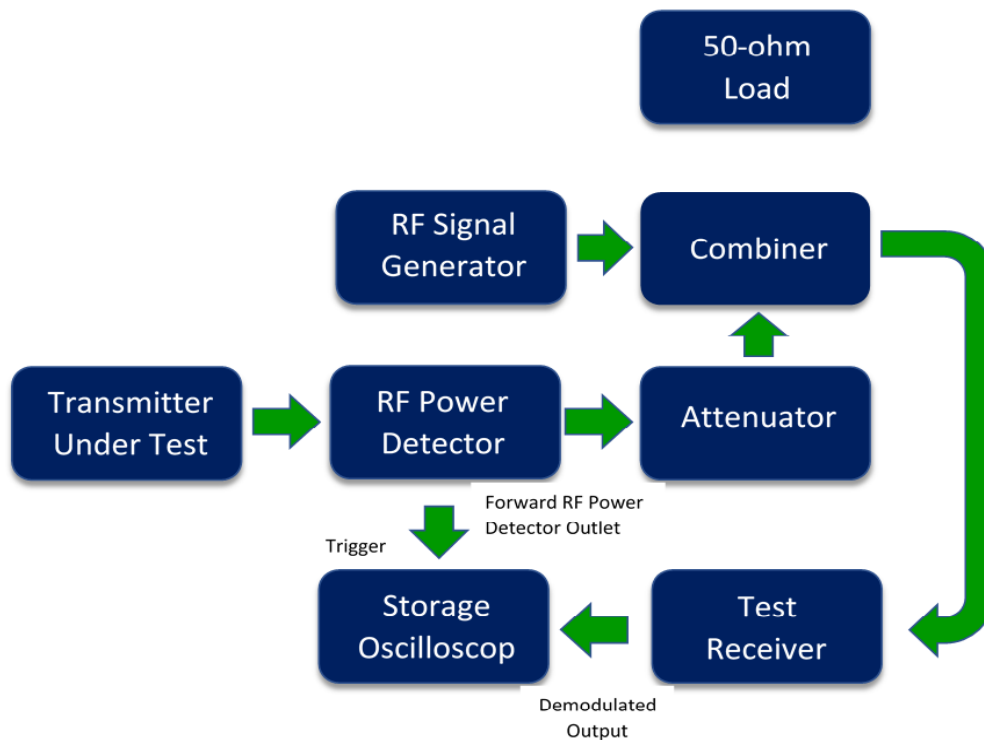
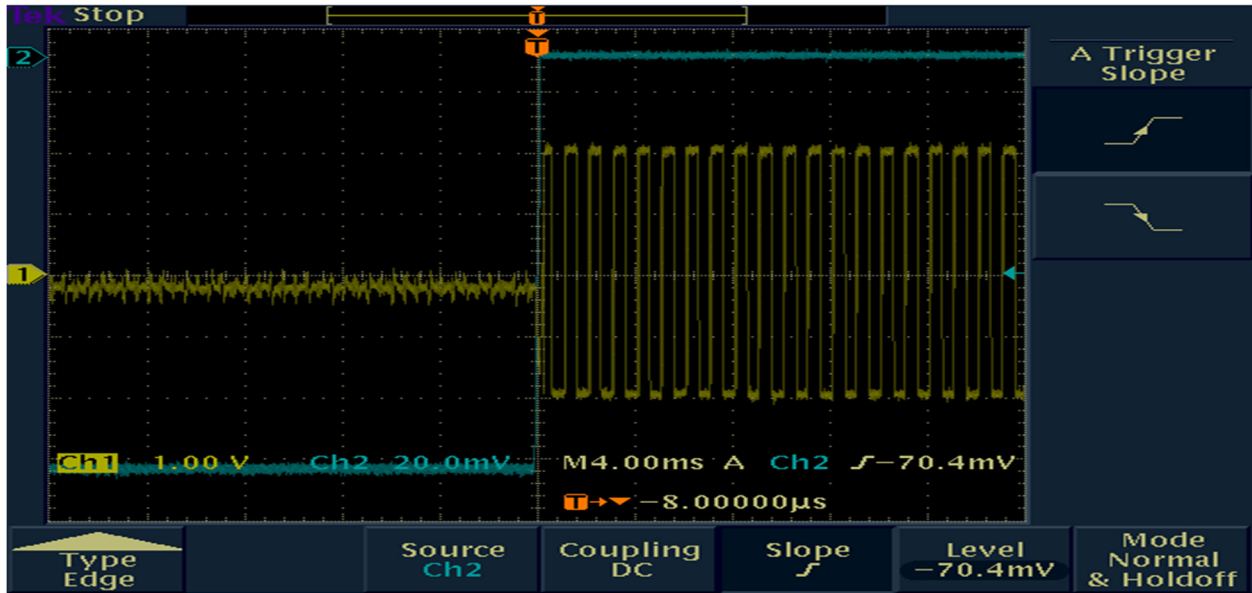
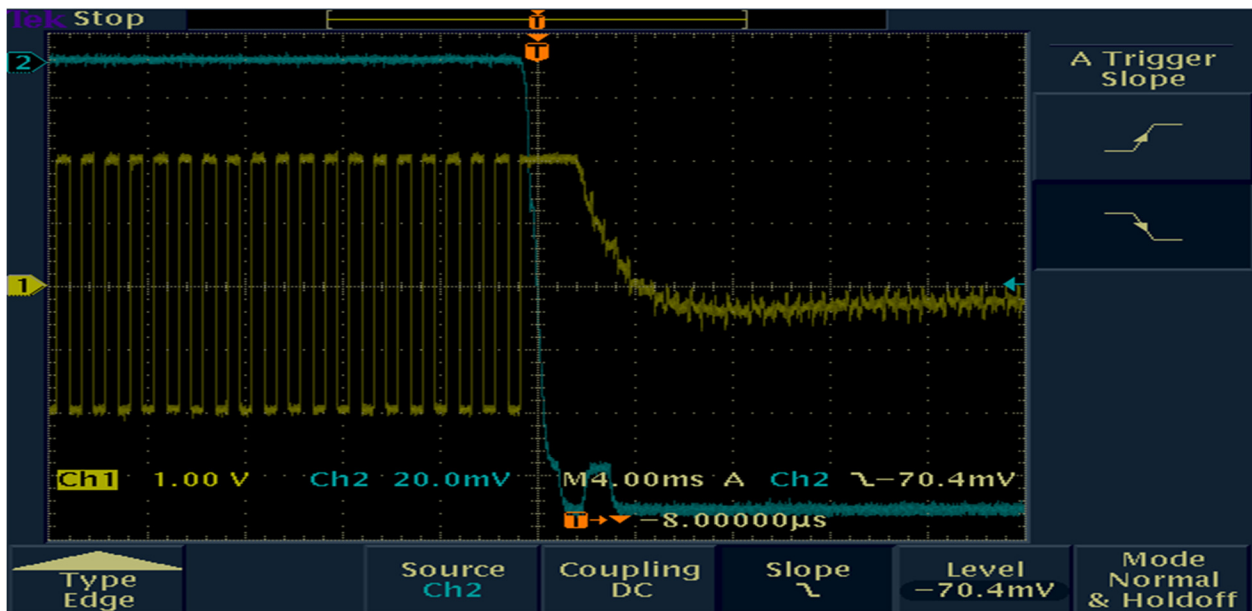


Figure 8 – Transient Frequency Behavior Test Setup



TDS 3052 - 5:10:00 PM 5/30/2018

Plot 20 – On Time



TDS 3052 - 5:03:14 PM 5/30/2018

Plot 21 – Off Time

9. Necessary Bandwidth

Referencing Part 2.202 of the FCC Rules and Regulation and using the following formula for calculating the Necessary Bandwidth

$$B = 2M + 2DK$$

Where M = Baud Rate, D = Deviation and K= Constant

Digital Data: 2 level FSK; 4800 bps; Narrow Band; 12.5 KHz Channel Spacing

Calculation

Data Rate in bps (R) = 4800

Peak Deviation of Carrier (D) = +/-1.8KHz

Number of States in Each Symbol = 2

$$B_n = 3.86 + 0.27R$$

$$B_N = [3.86*(1800) + 0.27*4800]=8.24 \text{ KHz}$$

Emission Designator: 8K20F1D

Digital Data: 2 level FSK; 9600 bps; Wide Band; 25 KHz Channel Spacing

Calculation

Data Rate in bps (R) = 9600

Peak Deviation of Carrier (D) = +/-2.2KHz

Number of States in Each Symbol = 2

$$B_n = 3.86 + 0.27R$$

$$B_N = [3.86*(2200) + 0.27*9600] = 11.0 \text{ KHz}$$

Emission Designator: 11K0F1D

I. Test Equipment

| Equipment | Manufacturer | Model | Serial # | Last Cal Date | Cal Due Date |
|------------------------|-----------------|-----------|----------------|---------------|--------------|
| Power Supply | Lambda | LA-200 | LA2AA201433535 | Verified | |
| Digital Multimeter | Fluke | 77 III | 72550270 | Jan/30/18 | Jan/30/20 |
| Spectrum Analyzer | Agilent | E4402B | US41192757 | Mar/19/18 | Mar/19/19 |
| Temperature Chamber | Thermotron | SM-3.5S | 12817 | Oct/17/17 | Oct/17/18 |
| Spectrum Analyzer | Hewlett Packard | 8563E | 3821A09316 | Jan/30/18 | Jan/30/19 |
| Attenuator 10dB | Huber+Suhner | 6810.17.A | 757300 | Verified | |
| High Pass Filter | Mini-Circuits | VHF-3100+ | 1023 | Verified | |
| Variable Attenuator | H.P. | None | None | NCR | None |
| EMI Receiver | Hewlett Packard | 8568B | 2314A02642 | Jul/11/17 | Jul/11/18 |
| Signal Generator | Agilent | E4432B | US38220446 | NCR | None |
| Attenuator 20dB | Weinschel | 41-20-12 | 86332 | Verified | |
| Horn Antenna | Com-Power | AHA-118 | 711150 | May/10/16 | May/10/19 |
| Horn Antenna | Com-Power | AH-118 | 71350 | Verified | |
| Bilog Antenna | Chase | CBL6140 | 1040 | Mar/30/16 | Mar/30/19 |
| Diode/Crystal Detector | H.P. | 8470B | None | Verified | |
| Combiner/Splitter | MiniCircuits | ZFSC-2-2 | None | Verified | |
| Oscilloscope | Tektronix | TDS 3052 | B013389 | Aug/18/17 | Aug/18/18 |

Table 10 – Test Equipment List

***Statement of Traceability:** Test equipment is maintained and calibrated on a regular basis. All calibrations have been performed by a 17025 accredited test facility, traceable to National Institute of Standards and Technology (NIST)

END OF TEST REPORT