



RF TEST REPORT

Applicant ZTE Corporation
FCC ID SRQ-ZTEZ999
Product LTE/WCDMA/GSM Multi-Mode Digital Mobile Phone
Marketing ZTE Axon M / ZTE AXON M / Axon M / AXON M
Model Z999
Report No. RXA1711-0362RF03
Issue Date December 1, 2017

TA Technology (Shanghai) Co., Ltd. tested the above equipment in accordance with the requirements in **FCC CFR47 Part 2 (2017)/ FCC CFR47 Part 27C (2017)**. The test results show that the equipment tested is capable of demonstrating compliance with the requirements as documented in this report.

Performed by: Jiangpeng Lan

Approved by: Kai Xu

TA Technology (Shanghai) Co., Ltd.

No.145, Jintang Rd, Tangzhen Industry Park, Pudong Shanghai, China

TEL: +86-021-50791141/2/3

FAX: +86-021-50791141/2/3-8000

Table of Contents

1	Test Laboratory.....	4
1.1	Notes of the Test Report.....	4
1.2	Test facility.....	4
1.3	Testing Location.....	5
2	General Description of Equipment under Test.....	6
3	Applied Standards.....	7
4	Test Configuration.....	8
5	Test Case Results.....	9
5.1	RF Power Output.....	9
5.2	Effective Isotropic Radiated Power.....	12
5.3	Occupied Bandwidth.....	16
5.4	Band Edge Compliance.....	22
5.5	Peak-to-Average Power Ratio (PAPR).....	30
5.6	Frequency Stability.....	32
5.7	Spurious Emissions at Antenna Terminals.....	35
5.8	Radiates Spurious Emission.....	43
6	Main Test Instruments.....	51
ANNEX A:	EUT Appearance and Test Setup.....	52
A.1	EUT Appearance.....	52
A.2	Test Setup.....	52

Summary of Measurement Results

Number	Test Case	Clause in FCC rules	Verdict
1	RF power output	2.1046	PASS
2	Effective Isotropic Radiated power	27.50(h)(2)	PASS
3	Occupied Bandwidth	2.1049	PASS
4	Band Edge Compliance	27.53(m)	PASS
5	Peak-to-Average Power Ratio	27.50(d)/KDB971168 D01(5.7)	PASS
6	Frequency Stability	2.1055 / 27.54	PASS
7	Spurious Emissions at Antenna Terminals	2.1051 /27.53(m)	PASS
8	Radiates Spurious Emission	2.1053 /27.53(m)	PASS
Date of Testing: November 9, 2017 ~ November 24, 2017			
Note: PASS: The EUT complies with the essential requirements in the standard. FAIL: The EUT does not comply with the essential requirements in the standard.			

1 Test Laboratory

1.1 Notes of the Test Report

This report shall not be reproduced in full or partial, without the written approval of **TA technology (shanghai) co., Ltd.** The results documented in this report apply only to the tested sample, under the conditions and modes of operation as described herein .Measurement Uncertainties were not taken into account and are published for informational purposes only. This report is written to support regulatory compliance of the applicable standards stated above. This report must not be used by the client to claim product certification, approval, or endorsement by any government agencies.

1.2 Test facility

CNAS (accreditation number: L2264)

TA Technology (Shanghai) Co., Ltd. has obtained the accreditation of China National Accreditation Service for Conformity Assessment (CNAS).

FCC (Designation number: CN1179, Test Firm Registration Number: 446626)

TA Technology (Shanghai) Co., Ltd. has been listed on the US Federal Communications Commission list of test facilities recognized to perform electromagnetic emissions measurements.

IC (recognition number is 8510A)

TA Technology (Shanghai) Co., Ltd. has been listed by industry Canada to perform electromagnetic emission measurement.

VCCI (recognition number is C-4595, T-2154, R-4113, G-10766)

TA Technology (Shanghai) Co., Ltd. has been listed by industry Japan to perform electromagnetic emission measurement.

A2LA (Certificate Number: 3857.01)

TA Technology (Shanghai) Co., Ltd. has been listed by American Association for Laboratory Accreditation to perform electromagnetic emission measurement.

1.3 Testing Location

Company: TA Technology (Shanghai) Co., Ltd.
Address: No.145, Jintang Rd, Tangzhen Industry Park, Pudong Shanghai, China
City: Shanghai
Post code: 201201
Country: P. R. China
Contact: Xu Kai
Telephone: +86-021-50791141/2/3
Fax: +86-021-50791141/2/3-8000
Website: <http://www.ta-shanghai.com>
E-mail: xukai@ta-shanghai.com

2 General Description of Equipment under Test

Client Information

Applicant	ZTE Corporation
Applicant address	ZTE Plaza, Keji Road South, Hi-Tech, Industrial Park, Nanshan District, Shenzhen, Guangdong, 518057, P.R.China
Manufacturer	ZTE Corporation
Manufacturer address	ZTE Plaza, Keji Road South, Hi-Tech, Industrial Park, Nanshan District, Shenzhen, Guangdong, 518057, P.R.China

General information

EUT Description			
Model	Z999		
IMEI	866733030002454		
Hardware Version	ZTE AXON M MP		
Software Version	AXONMB01-DE_ACC01a		
Power Supply	Battery/AC adapter		
Antenna Type	Internal Antenna		
Test Mode(s)	LTE Band 7		
Test Modulation	QPSK 16QAM;		
LTE Category	6		
Maximum E.I.R.P./ E.R.P.	LTE Band 7:	20.25dBm	
Rated Power Supply Voltage:	3.85V		
Extreme Voltage	Minimum: 3.6V Maximum: 4.4V		
Extreme Temperature	Lowest: -10°C Highest: +55°C		
	Mode	Tx (MHz)	Rx (MHz)
Operating Frequency Range(s)	LTE Band 7	2500 ~ 2570	2620 ~ 2690
EUT Accessory			
Battery	Manufacturer: SCUD (Fujian) Electronics Co., Ltd. Model: Li3931T44P8h686049		
Earphone	Manufacturer: KINGSTATE ELECTRONICS CORP. Model: KJAG4020AWKCB-2		
Note: 1. The information of the EUT is declared by the manufacturer.			

3 Applied Standards

According to the specifications of the manufacturer, it must comply with the requirements of the following standards:

Test standards

FCC CFR47 Part 2 (2017)

FCC CFR47 Part 27C (2017)

ANSI/TIA-603-D (2010)

KDB 971168 D01 Power Meas License Digital Systems v03

4 Test Configuration

Radiated measurements are performed by rotating the EUT in three different orthogonal test planes. EUT stand-up position (Z axis), lie-down position (X, Y axis). Receiver antenna polarization (horizontal and vertical), the worst emission was found in position (X axis, horizontal polarization) and the worst case was recorded.

All mode and data rates and positions and RB size and modulations were investigated.

Subsequently, only the worst case emissions are reported.

The following testing in LTE is set based on the maximum RF Output Power.

The following testing in different Bandwidth is set to detail in the following table:

Test modes are chosen to be reported as the worst case configuration below for LTE Band 7

Test items	Bandwidth (MHz)				Modulation		RB			Test Channel		
	5	10	15	20	QPSK	16QAM	1	50%	100%	L	M	H
RF power output	O	O	O	O	O	O	O	O	O	O	O	O
Effective Isotropic Radiated power	O	O	O	O	O	O	-	-	O	O	O	O
Occupied Bandwidth	O	O	O	O	O	O	-	-	O	O	O	O
Band Edge Compliance	O	O	O	O	O	O	O	-	O	O	-	O
Peak-to-Average Power Ratio	O	O	O	O	O	O	-	-	O	O	O	O
Frequency Stability	O	O	O	O	O	O	-	-	O	-	O	-
Spurious Emissions at Antenna Terminals	O	O	O	O	O	-	O	-	-	O	O	O
Radiates Spurious Emission	O	O	O	O	O	-	O	-	-	O	O	O
Note	1. The mark "O" means that this configuration is chosen for testing. 2. The mark "-" means that this configuration is not testing.											

5 Test Case Results

5.1 RF Power Output

Ambient condition

Temperature	Relative humidity	Pressure
23°C ~25°C	45%~50%	101.5kPa

Methods of Measurement

During the process of the testing, The EUT is controlled by the Base Station Simulator to ensure max power transmission and proper modulation.

Test Setup

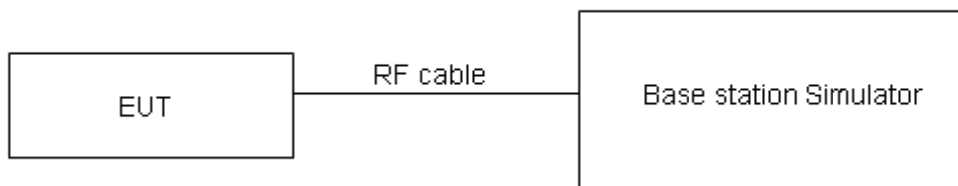

The loss between RF output port of the EUT and the input port of the tester has been taken into consideration.

Limits

No specific RF power output requirements in part 2.1046.

Measurement Uncertainty

The assessed measurement uncertainty to ensure 95% confidence level for the normal distribution is with the coverage factor $k = 2$, $U=0.4$ dB.

Test Results

LTE Band 7				Conducted Power(dBm)		
Bandwidth	Modulation	RB size	RB offset	Channel/Frequency (MHz)		
				20775/2502.5	21100/2535	21425/2567.5
5MHz	QPSK	1	0	23.00	22.93	22.99
		1	13	22.79	22.84	22.84
		1	24	22.77	22.89	22.96
		12	0	21.81	21.85	21.85
		12	6	21.73	21.90	21.87
		12	13	21.77	21.82	21.86
		25	0	21.52	21.78	21.94
	16QAM	1	0	21.76	21.75	22.00
		1	13	21.89	21.95	21.75
		1	24	21.80	21.96	22.00
		12	0	20.71	20.73	20.80
		12	6	20.83	20.92	20.88
		12	13	20.66	20.78	20.86
		25	0	20.65	20.85	20.94
Bandwidth	Modulation	RB size	RB offset	Channel/Frequency (MHz)		
				20800/2505	21100/2535	21400/2565
10MHz	QPSK	1	0	23.02	22.94	23.02
		1	25	22.82	22.89	22.88
		1	49	22.79	22.93	22.99
		25	0	21.84	21.90	21.89
		25	13	21.76	21.95	21.91
		25	25	21.79	21.86	21.91
		50	0	21.60	21.80	21.98
	16QAM	1	0	21.78	21.78	22.02
		1	25	21.92	21.99	21.78
		1	49	21.83	21.98	22.03
		25	0	20.74	20.78	20.84
		25	13	20.85	20.96	20.91
		25	25	20.69	20.83	20.90
		50	0	20.68	20.90	20.98
Bandwidth	Modulation	RB size	RB offset	Channel/Frequency (MHz)		
				20825/2507.5	21100/2535	21375/2562.5
15MHz	QPSK	1	0	23.01	22.90	23.00
		1	38	22.80	22.88	22.85
		1	74	22.76	22.88	22.95
		36	0	21.82	21.86	21.86
		36	18	21.73	21.90	21.87
		36	39	21.76	21.83	21.87
		75	0	21.58	21.76	21.93



Bandwidth	Modulation	RB size	RB offset	Channel/Frequency (MHz)		
				20850/2510	21100/2535	21350/2560
20MHz	16QAM	1	0	21.73	21.76	22.00
		1	38	21.90	21.96	21.76
		1	74	21.80	21.94	22.00
		36	0	20.71	20.76	20.81
		36	18	20.82	20.91	20.87
		36	39	20.67	20.79	20.87
		75	0	20.65	20.85	20.94
	QPSK	1	0	22.98	22.86	22.97
		1	50	22.79	22.84	22.83
		1	99	22.74	22.87	22.92
		50	0	21.79	21.81	21.82
		50	25	21.71	21.86	21.84
		50	50	21.73	21.78	21.83
		100	0	21.55	21.71	21.89
16QAM	1	0	21.71	21.72	21.95	
	1	50	21.86	21.94	21.72	
	1	99	21.78	21.91	21.98	
	50	0	20.68	20.72	20.78	
	50	25	20.79	20.89	20.84	
	50	50	20.64	20.74	20.83	
	100	0	20.63	20.81	20.91	

5.2 Effective Isotropic Radiated Power

Ambient condition

Temperature	Relative humidity	Pressure
23°C ~25°C	45%~50%	101.5kPa

Methods of Measurement

1. The testing follows FCC KDB 971168 v03 Section 5.8 and ANSI/TIA-603-D-2010.

a) Connect the equipment as illustrated. Mount the equipment with the manufacturer specified antenna in a vertical orientation on a manufacturer specified mounting surface located on a non-conducting rotating platform of a RF anechoic chamber (preferred) or a standard radiation site.

b) Key the transmitter, then rotate the EUT 360° azimuthally and record spectrum analyzer power level (LVL) measurements at angular increments that are sufficiently small to permit resolution of all peaks. If a standard radiation test site is used, raise and lower the test antenna to obtain a maximum reading at each angular increment. (Note: several batteries may be needed to offset the effect of battery voltage droop, which should not exceed 5% of the manufactured specified battery voltage during transmission).

c) Replace the transmitter under test with a vertically polarized half-wave dipole (or an antenna whose gain is known relative to an ideal half-wave dipole). The center of the antenna should be at the same location as the center of the antenna under test.

d) Connect the antenna to a signal generator with a known output power and record the path loss (in dB) as LOSS. If a standard radiation test site is used, raise and lower the test antenna to obtain a maximum reading. $LOSS = \text{Generator Output Power (dBm)} - \text{Analyzer reading (dBm)}$

e) Determine the effective radiated output power at each angular position from the readings in steps b) and d) using the following equation: $ERP \text{ (dBm)} = LVL \text{ (dBm)} + LOSS \text{ (dB)}$

f) The maximum ERP is the maximum value determined in the preceding step.

g) When calculating ERP, in addition to knowing the antenna radiation and matching characteristics, it is necessary to know the loss values of all elements (e.g. transmission line attenuation, mismatches, filters, combiners) interposed between the point where transmitter output power is measured, and the point where power is applied to the antenna. ERP can then be calculated as follows:

$$ERP \text{ (dBm)} = \text{Output Power (dBm)} - \text{Losses (dB)} + \text{Antenna Gain (dBd)}$$

where: dBd refers to gain relative to an ideal dipole.

$$EIRP \text{ (dBm)} = ERP \text{ (dBm)} + 2.15 \text{ (dB.)}$$

Test setup

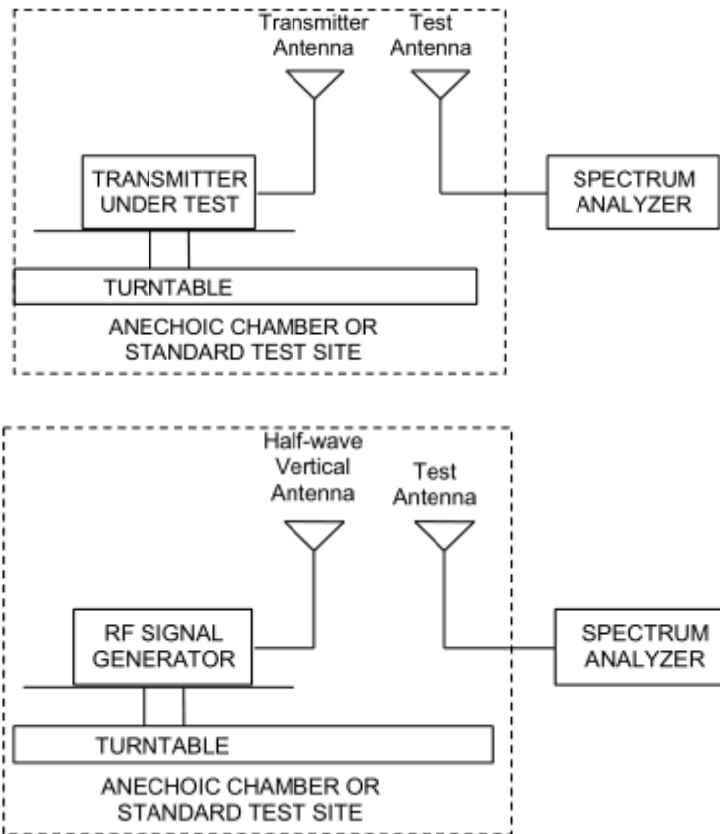

Note: Area side:2.4mX3.6m

The radiated emission was measured in the following position: EUT stand-up position (Z axis), lie-down position (X, Y axis). The worst emission was found in stand-up position (Z axis) and the worst case was recorded.

**Limits**

Rule Part 27.50(h) (2) specifies that “Mobile and other user stations. Mobile stations are limited to 2.0 watts EIRP. All user stations are limited to 2.0 watts transmitter output power.”

Part 27.50(h)(2) Limit (EIRP)	$\leq 2 \text{ W}$ (33 dBm)
-------------------------------	-----------------------------

Measurement Uncertainty

The assessed measurement uncertainty to ensure 95% confidence level for the normal distribution is with the coverage factor $k = 2$, $U = 1.19 \text{ dB}$

**Test Results**

The measurement is performed for both of horizontal and vertical antenna Polarization, and only the data of worst mode is recorded in this report.

LTE Band 7									
Band width	Channel	Frequency (MHz)	Polarization	Output Power (dBm)	Losses (dB)	Antenna Gain (dBd)	EIRP (dBm)	Limit (dBm)	Conclusion
5 MHz (QPSK)	Low	2502.5	Horizontal	-42.09	-59.64	1.81	19.36	33	Pass
	Mid	2535	Horizontal	-42.57	-59.72	1.81	18.96	33	Pass
	High	2567.5	Horizontal	-41.56	-59.98	1.83	20.25	33	Pass
10 MHz (QPSK)	Low	2505	Horizontal	-41.99	-59.61	1.82	19.44	33	Pass
	Mid	2535	Horizontal	-42.44	-59.72	1.81	19.09	33	Pass
	High	2565	Horizontal	-41.70	-60.02	1.81	20.13	33	Pass
15 MHz (QPSK)	Low	2507.5	Horizontal	-41.85	-59.29	1.80	19.24	33	Pass
	Mid	2535	Horizontal	-42.68	-59.72	1.81	18.85	33	Pass
	High	2562.5	Horizontal	-41.42	-59.46	1.82	19.86	33	Pass
20 MHz (QPSK)	Low	2510	Horizontal	-41.96	-59.52	1.77	19.33	33	Pass
	Mid	2535	Horizontal	-42.68	-59.72	1.81	18.85	33	Pass
	High	2560	Horizontal	-41.93	-60.01	1.82	19.91	33	Pass
5 MHz (16QAM)	Low	2502.5	Horizontal	-42.20	-59.64	1.81	19.25	33	Pass
	Mid	2535	Horizontal	-42.68	-59.72	1.81	18.85	33	Pass
	High	2567.5	Horizontal	-41.68	-59.98	1.83	20.13	33	Pass
10 MHz (16QAM)	Low	2505	Horizontal	-42.10	-59.61	1.82	19.33	33	Pass
	Mid	2535	Horizontal	-42.55	-59.72	1.81	18.98	33	Pass
	High	2565	Horizontal	-41.82	-60.02	1.81	20.01	33	Pass
15 MHz (16QAM)	Low	2507.5	Horizontal	-41.97	-59.29	1.80	19.12	33	Pass
	Mid	2535	Horizontal	-42.79	-59.72	1.81	18.74	33	Pass
	High	2562.5	Horizontal	-41.53	-59.46	1.82	19.75	33	Pass
20 MHz (16QAM)	Low	2510	Horizontal	-42.07	-59.52	1.77	19.22	33	Pass
	Mid	2535	Horizontal	-42.80	-59.72	1.81	18.73	33	Pass
	High	2560	Horizontal	-42.04	-60.01	1.82	19.79	33	Pass

Note: 1. EIRP= E.R.P+2.15

5.3 Occupied Bandwidth

Ambient condition

Temperature	Relative humidity	Pressure
23°C ~25°C	45%~50%	101.5kPa

Method of Measurement

The EUT was connected to Spectrum Analyzer and Base Station Simulator via power Splitter. The occupied bandwidth is measured using spectrum analyzer.

RBW is set to 100 kHz, VBW is set to 300 kHz for LTE Band 7 (5MHz).

RBW is set to 300 kHz, VBW is set to 1MHz for LTE Band 7 (10MHz/15MHz/20MHz).

99% power and -26dBc occupied bandwidths are recorded. Spectrum analyzer plots are included on the following pages.

Test Setup

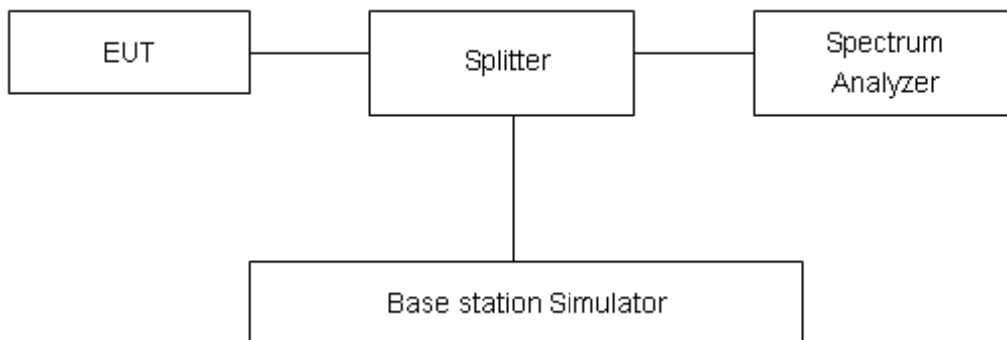

Limits

No specific occupied bandwidth requirements in part 2.1049.

Measurement Uncertainty

The assessed measurement uncertainty to ensure 95% confidence level for the normal distribution is with the coverage factor $k = 2$, $U=624\text{Hz}$.

Test Result

LTE Band 7						
RB	Modulation	Bandwidth (MHz)	Channel	Frequency (MHz)	99% Power Bandwidth(MHz)	-26dBc Bandwidth(MHz)
100%	QPSK	5	20775	2502.5	4.5329	4.992
			21100	2535	4.5070	4.983
			21425	2567.5	4.5096	5.003
		10	20800	2505	9.0598	10.060
			21100	2535	9.0467	9.986
			21400	2565	9.0503	10.000
		15	20825	2507.5	13.554	14.830
			21100	2535	13.475	14.720
			21375	2562.5	13.478	14.780
		20	20850	2510	17.913	19.230
			21100	2535	17.972	19.500
			21350	2560	17.940	19.620
	16QAM	5	20775	2502.5	4.5136	5.001
			21100	2535	4.5356	4.983
			21425	2567.5	4.5375	4.999
		10	20800	2505	9.0753	9.980
			21100	2535	9.0515	9.925
			21400	2565	9.0435	10.000
		15	20825	2507.5	13.522	14.750
			21100	2535	13.530	14.730
			21375	2562.5	13.499	14.790
		20	20850	2510	17.980	19.360
			21100	2535	17.952	19.490
			21350	2560	17.909	19.410



LTE Band 7 QPSK 5MHz CH-Low

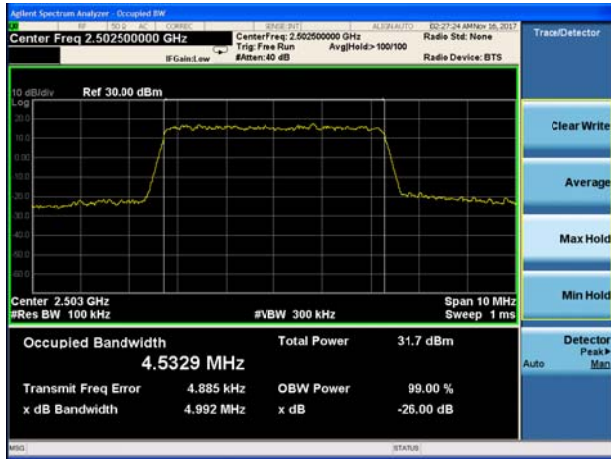

LTE Band 7 QPSK 10MHz CH-Low



LTE Band 7 QPSK 5MHz CH-Middle

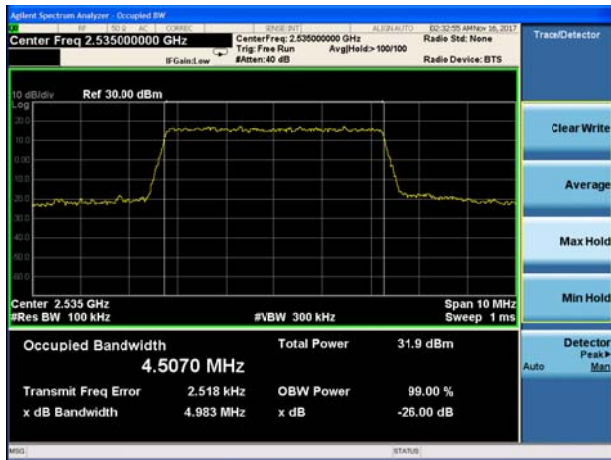

LTE Band 7 QPSK 10MHz CH-Middle



LTE Band 7 QPSK 5MHz CH-High

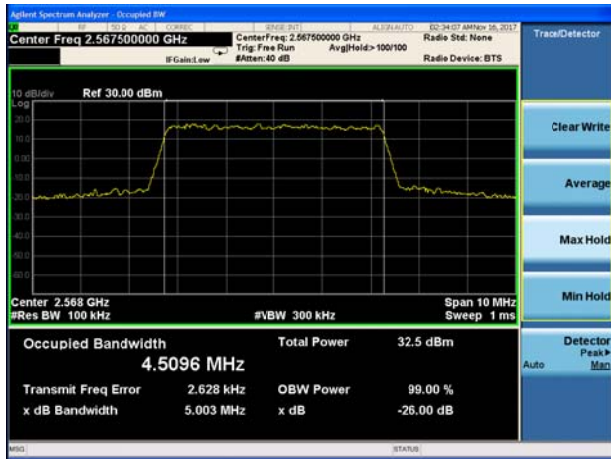

LTE Band 7 QPSK 10MHz CH-High



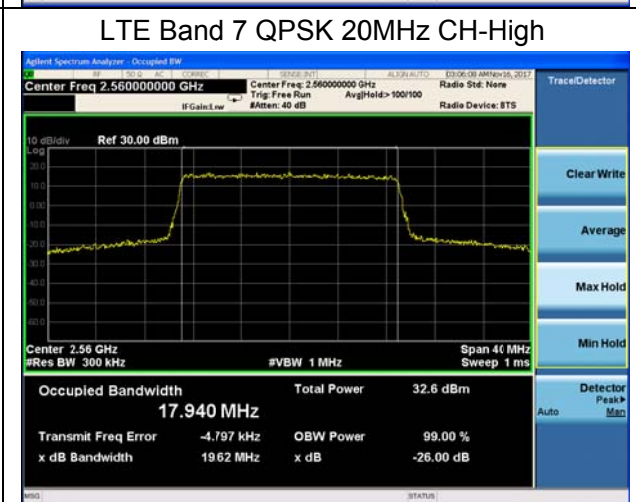
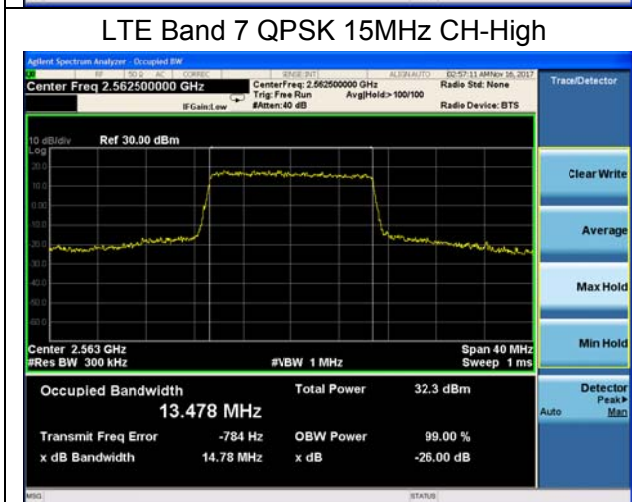
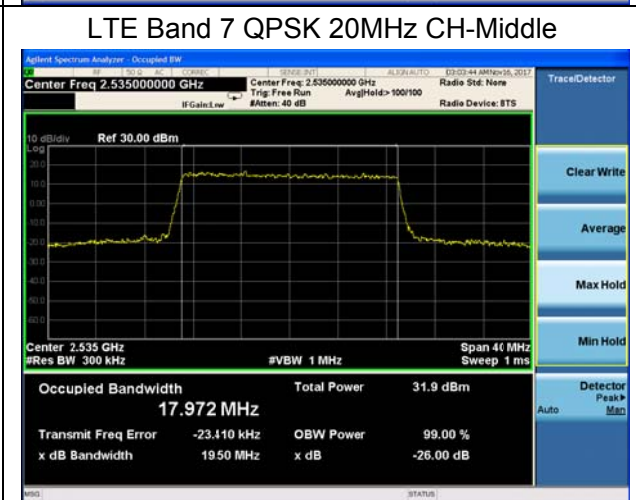
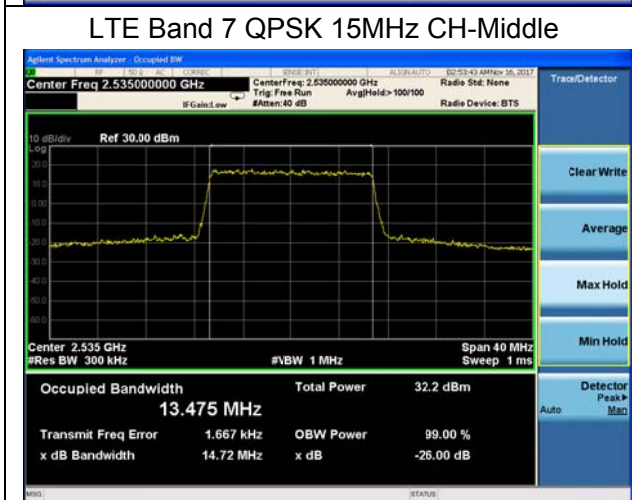
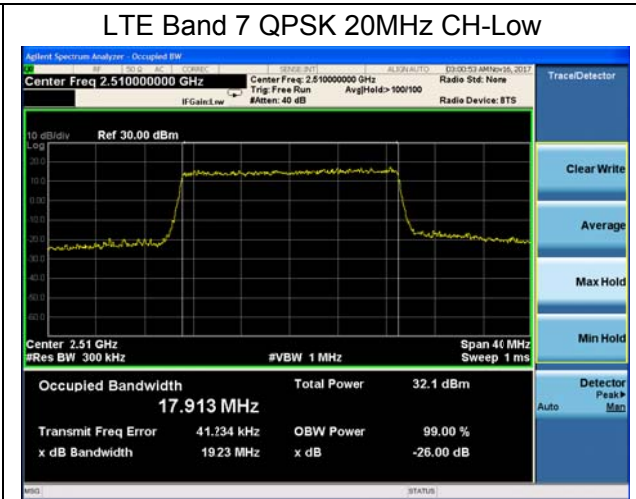
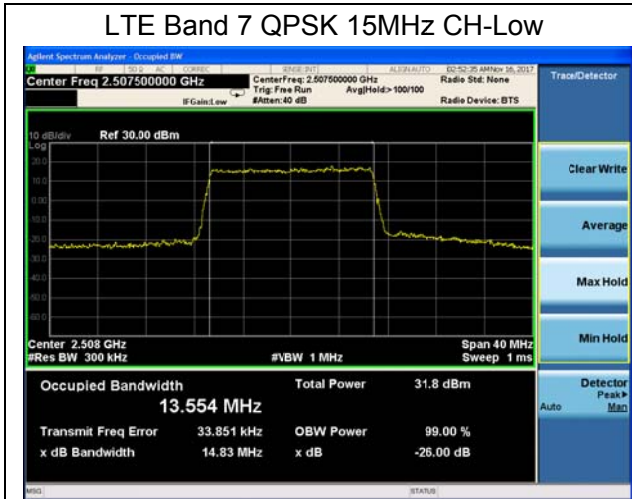

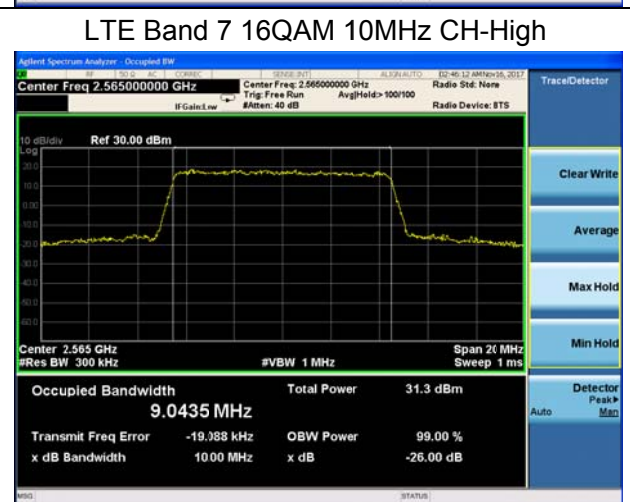
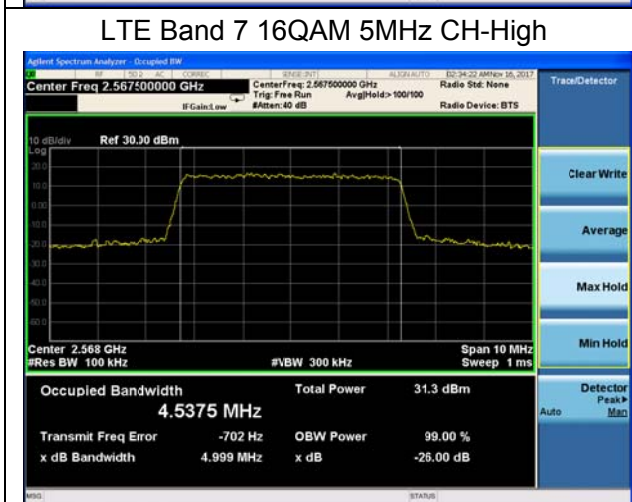
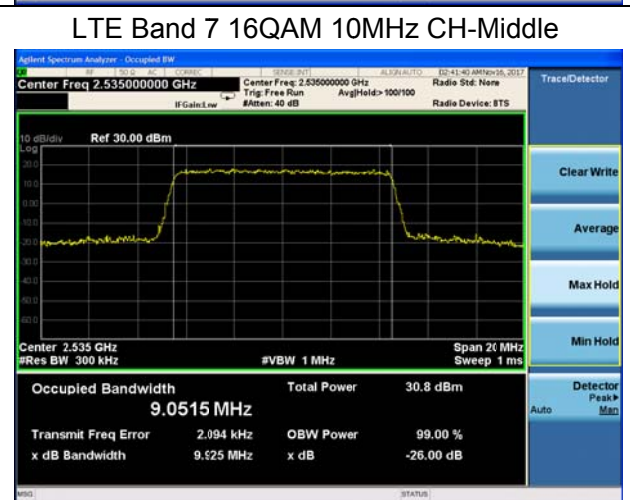
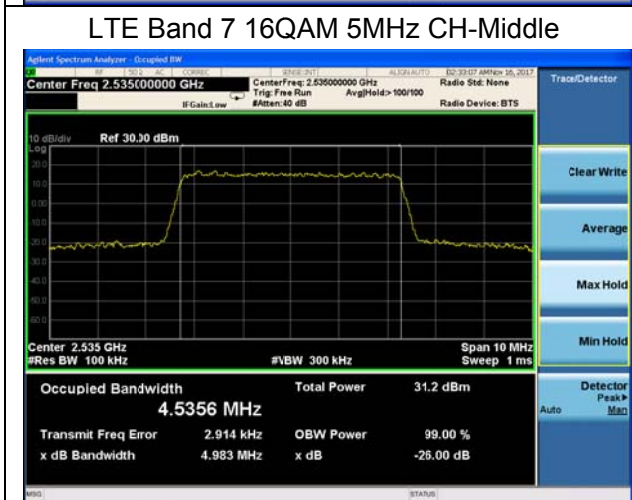
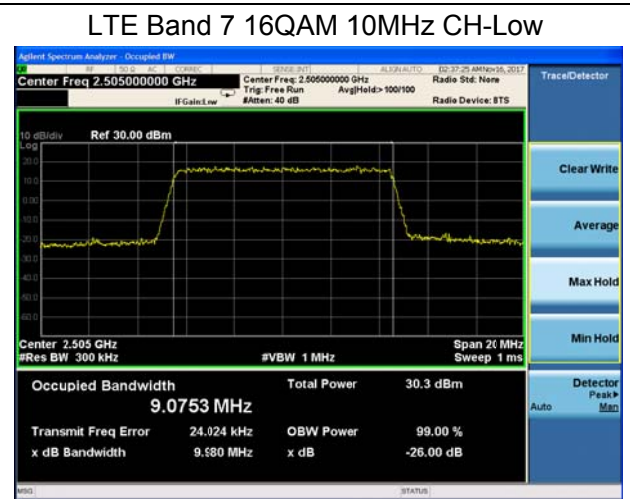
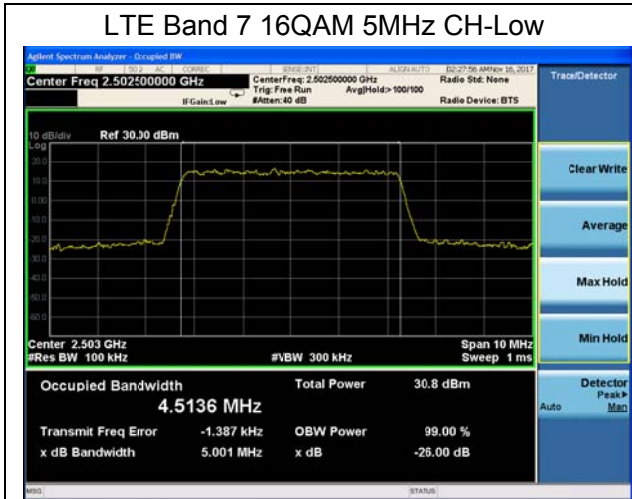

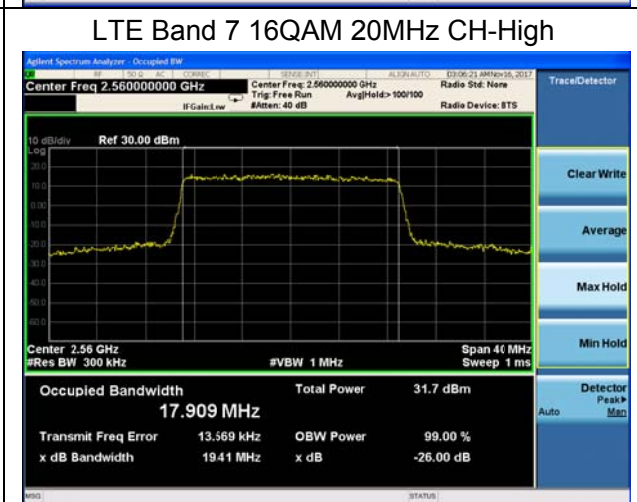
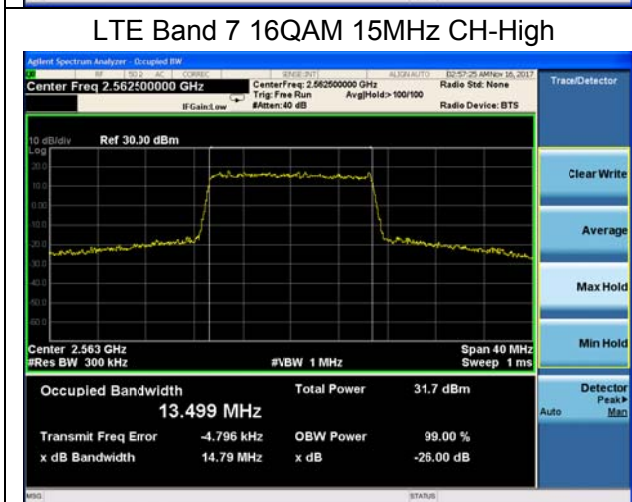
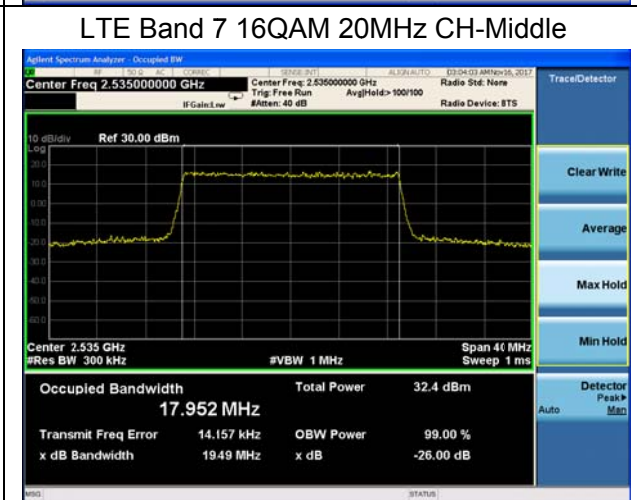
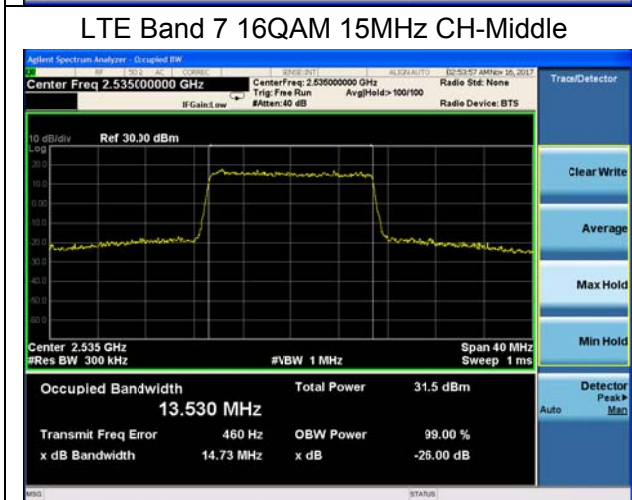
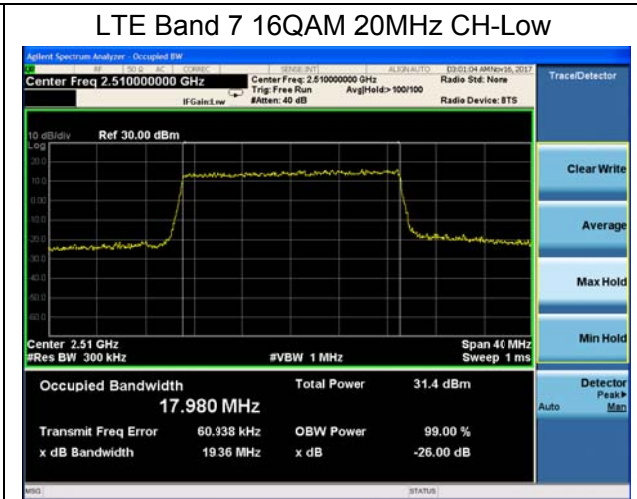
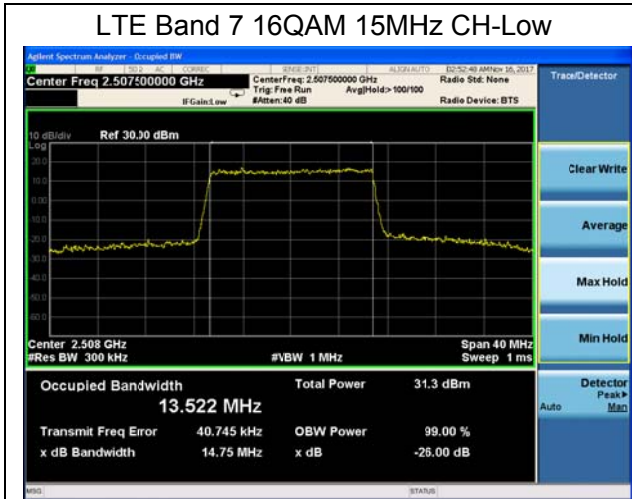

5.4 Band Edge Compliance

Ambient condition

Temperature	Relative humidity	Pressure
23°C ~25°C	45%~50%	101.5kPa

Method of Measurement

The EUT was connected to Spectrum Analyzer and Base Station Simulator via power Splitter. The band edge of the lowest and highest channels were measured.

The testing follows KDB 971168 v03 Section 6.0

- 1.The EUT was connected to spectrum analyzer and system simulator via a power divider.
2. The band edges of low and high channels for the highest RF powers were measured.
3. For mobile digital stations, in the 1 megahertz bands immediately outside and adjacent to the frequency block a resolution bandwidth of at least two percent may be employed, except when the 1 megahertz band is 2495-2496 MHz, in which case a resolution bandwidth of at least one percent may be employed.
4. Set spectrum analyzer with RMS detector.
5. The RF fundamental frequency should be excluded against the limit line in the operating frequency band.
6. Checked that all the results comply with the emission limit line.

Test Setup

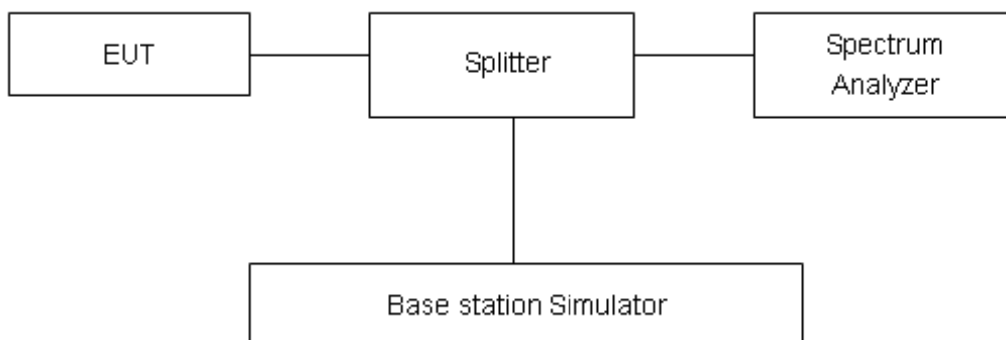

Limits

Part 27.53(m) (4) specifies that “for BRS and EBS stations. For mobile digital stations, the attenuation factor shall be not less than $40 + 10 \log (P)$ dB on all frequencies between the channel edge and 5 megahertz from the channel edge, $43 + 10 \log (P)$ dB on all frequencies between 5 megahertz and X megahertz from the channel edge, and $55 + 10 \log (P)$ dB on all frequencies more than X megahertz from the channel edge, where X is the greater of 6 megahertz or the actual emission bandwidth as defined in paragraph (m)(4) of this section. In addition, the attenuation factor shall not be less that $43 + 10 \log (P)$ dB on all frequencies between 2490.5 MHz and 2496 MHz and $55 + 10 \log (P)$ dB at or below 2490.5 MHz. Mobile Satellite Service licensees operating on frequencies below 2495 MHz may also submit a documented interference complaint against BRS licensees operating on channel BRS Channel 1 on the same terms and conditions as adjacent channel BRS or EBS licensees.

Example:

The limit line is derived from $43 + 10 \log (P)$ dB below the transmitter power P(Watts)

$$= P(W) - [43 + 10 \log(P)] \text{ (dB)}$$

$$= [30 + 10 \log (P)] \text{ (dBm)} - [43 + 10 \log(P)] \text{ (dB)} = -13 \text{ dBm.}$$

Measurement Uncertainty

The assessed measurement uncertainty to ensure 95% confidence level for the normal distribution is with the coverage factor $k = 1.96$, $U=0.684$ dB.

Test Result

All the test traces in the plots shows the test results clearly.

LTE Band 7 QPSK 5MHz CH-Low, 1 RB

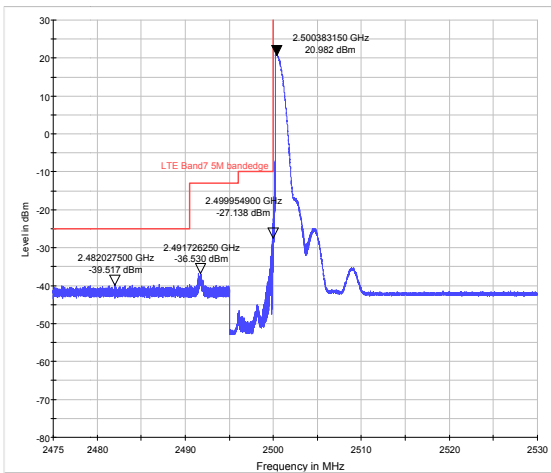

LTE Band 7 QPSK 5MHz CH-High, 1 RB

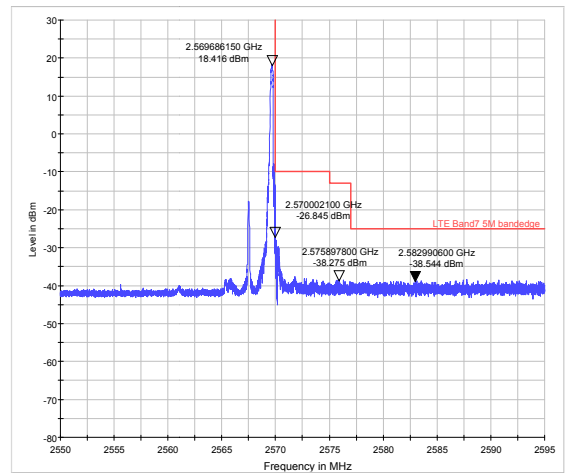

LTE Band 7 QPSK 5MHz CH-Low, 100%RB

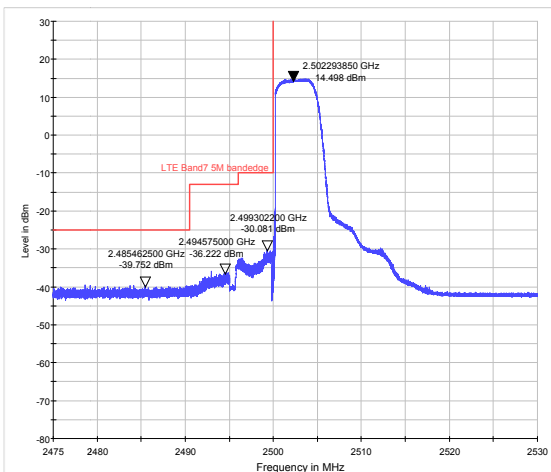

LTE Band 7 QPSK 5MHz CH-High, 100%RB

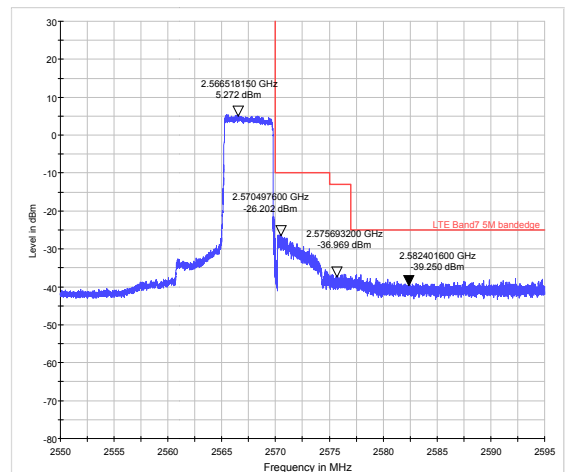

LTE Band 7 QPSK 10MHz CH-Low, 1 RB

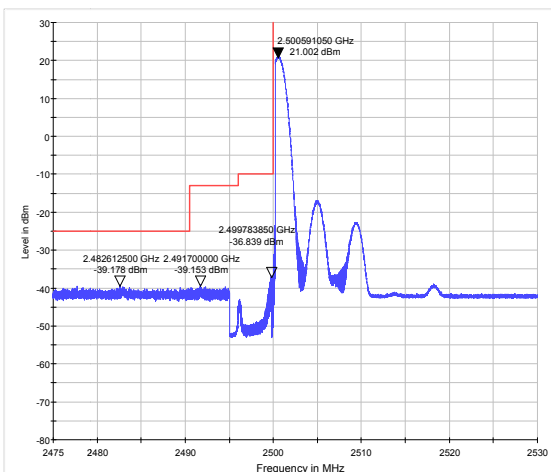

LTE Band 7 QPSK 10MHz CH-High, 1 RB

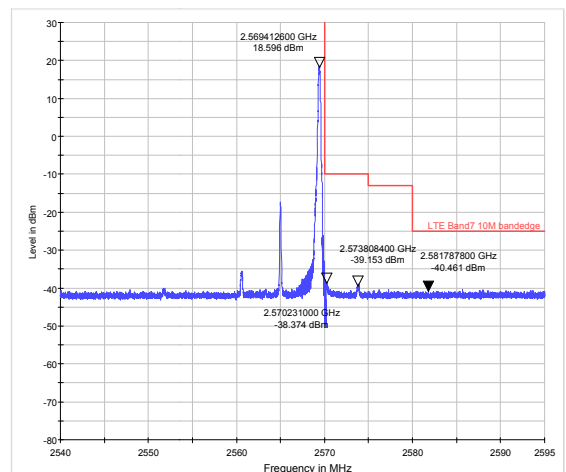



LTE Band 7 QPSK 10MHz CH-Low, 100%RB

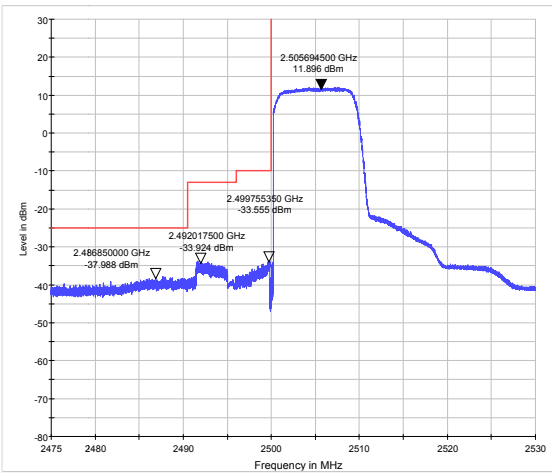

LTE Band 7 QPSK 10MHz CH-High, 100%RB

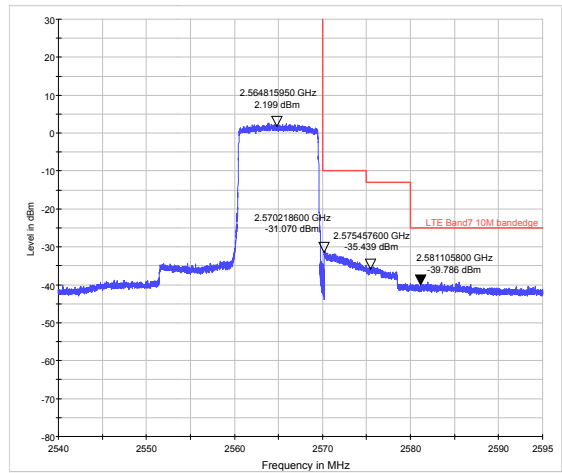

LTE Band 7 QPSK 15MHz CH-Low, 1 RB

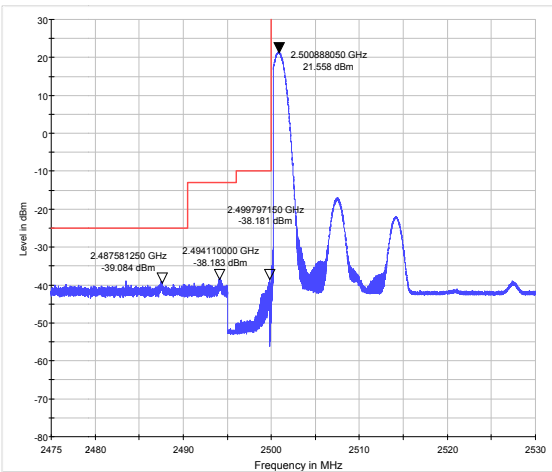

LTE Band 7 QPSK 15MHz CH-High, 1 RB

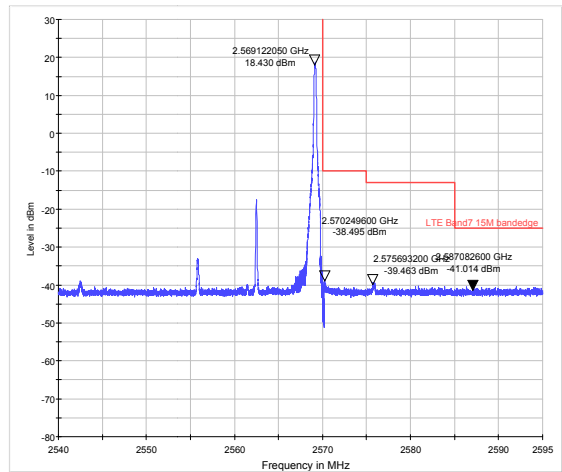

LTE Band 7 QPSK 15MHz CH-Low, 100%RB

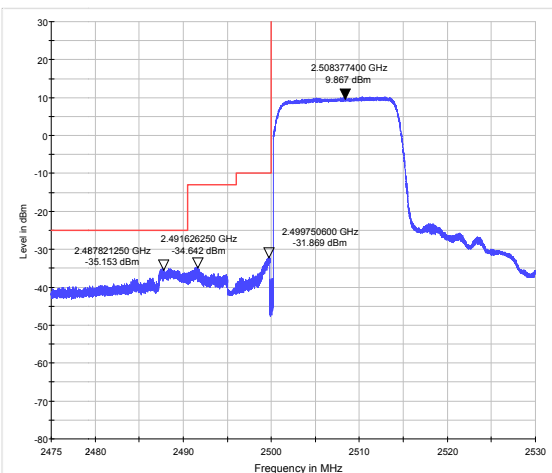

LTE Band 7 QPSK 15MHz CH-High, 100%RB

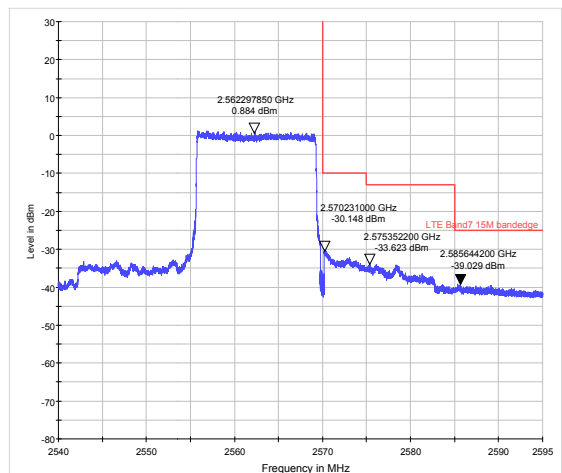



LTE Band 7 QPSK 20MHz CH-Low, 1 RB

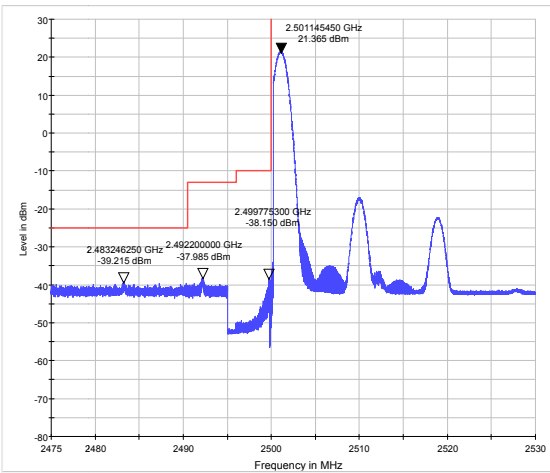

LTE Band 7 QPSK 20MHz CH-High, 1 RB

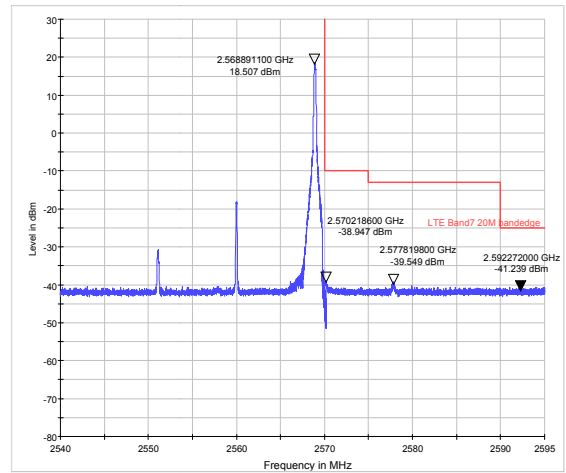

LTE Band 7 QPSK 20MHz CH-Low, 100%RB

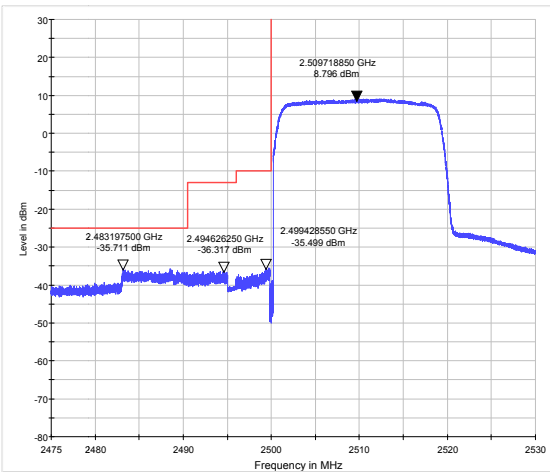

LTE Band 7 QPSK 20MHz CH-High, 100%RB

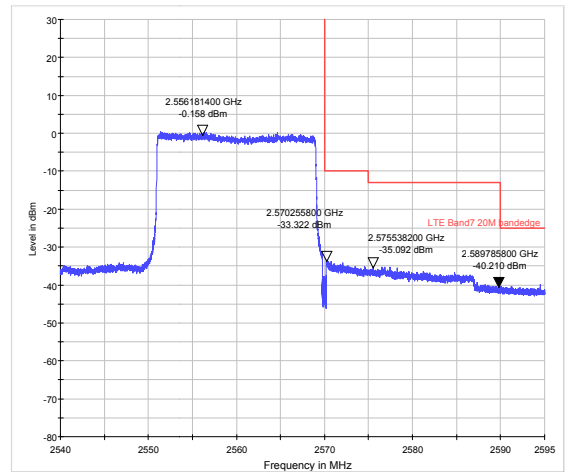

LTE Band 7 16QAM 5MHz CH-Low, 1 RB

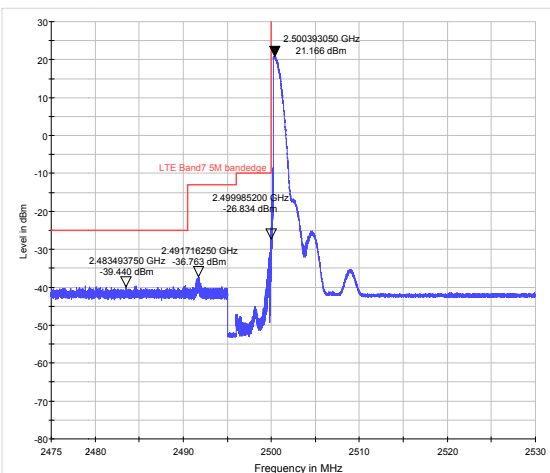

LTE Band 7 16QAM 5MHz CH-High, 1 RB

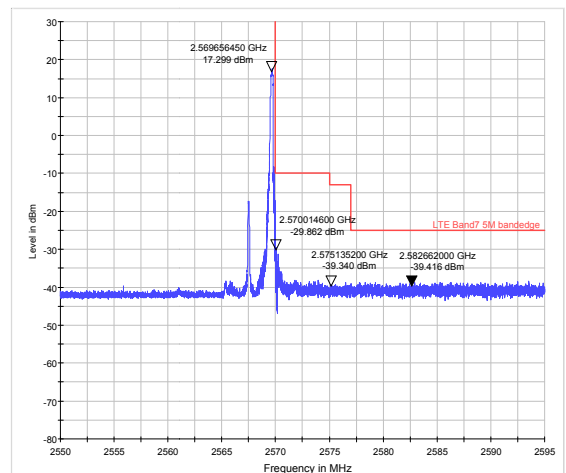



LTE Band 7 16QAM 5MHz CH-Low, 100%RB

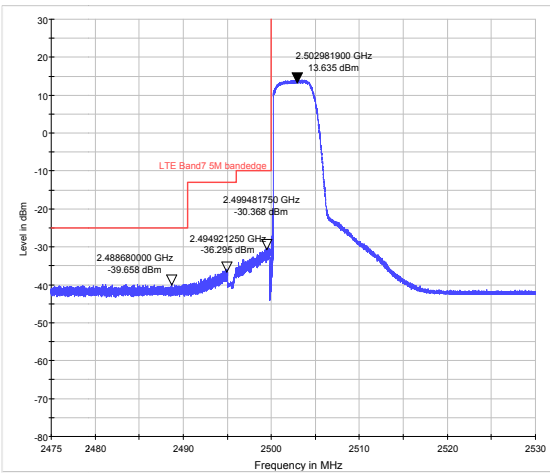

LTE Band 7 16QAM 5MHz CH-High, 100%RB

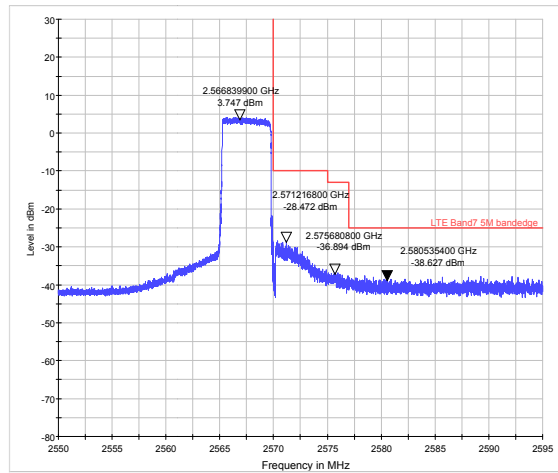

LTE Band 7 16QAM 10MHz CH-Low, 1 RB

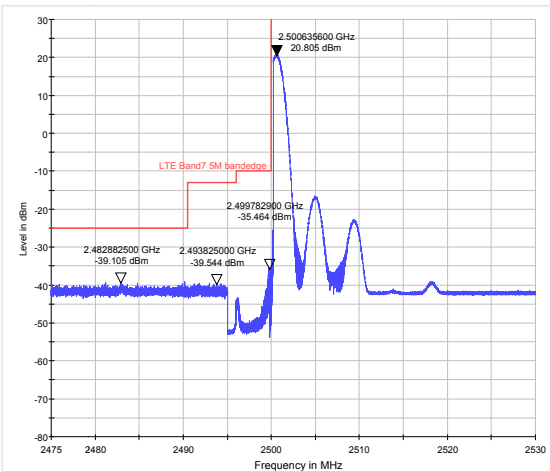

LTE Band 7 16QAM 10MHz CH-High, 1 RB

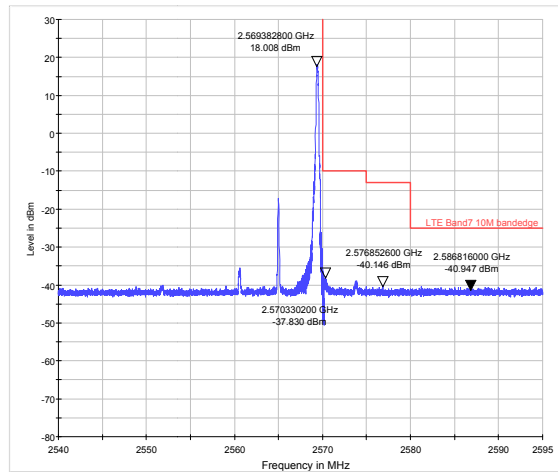

LTE Band 7 16QAM 10MHz CH-Low, 100%RB

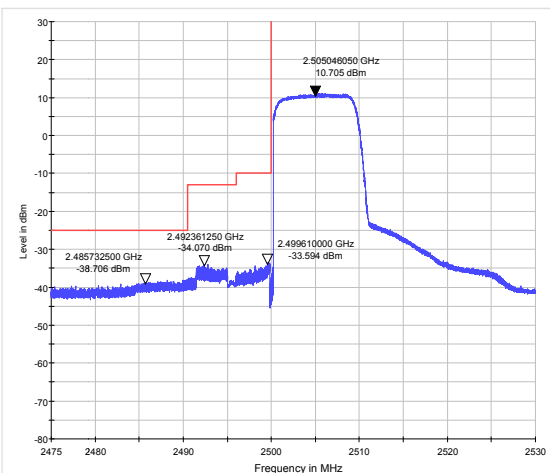

LTE Band 7 16QAM 10MHz CH-High, 100%RB

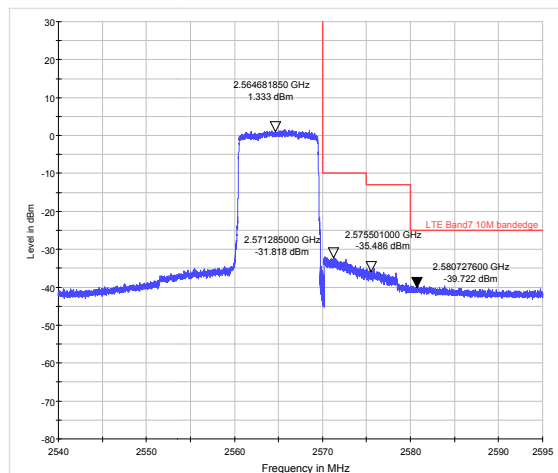



LTE Band 7 16QAM 15MHz CH-Low, 1 RB

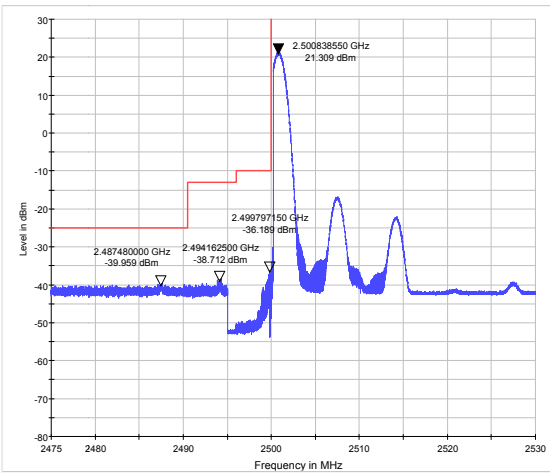

LTE Band 7 16QAM 15MHz CH-High, 1 RB

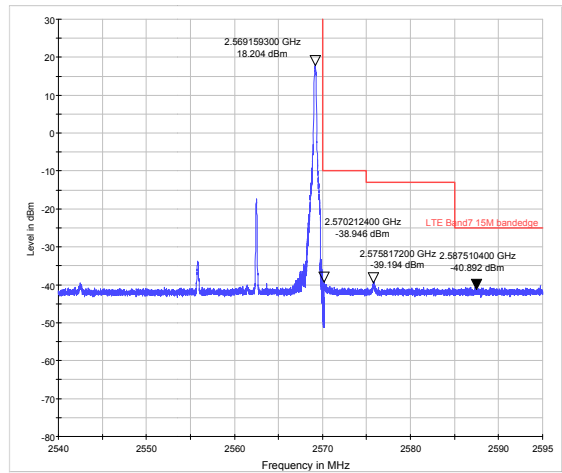

LTE Band 7 16QAM 15MHz CH-Low, 100%RB

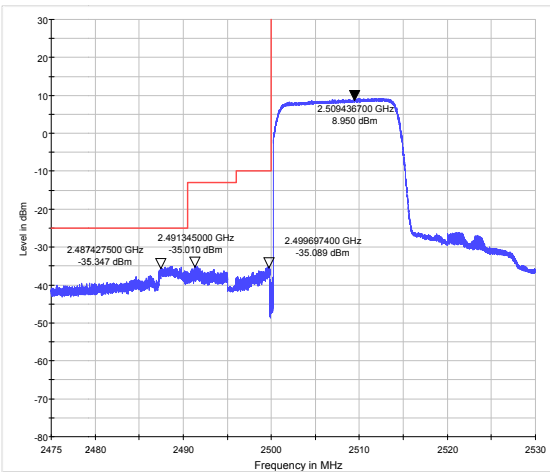

LTE Band 7 16QAM 15MHz CH-High, 100%RB

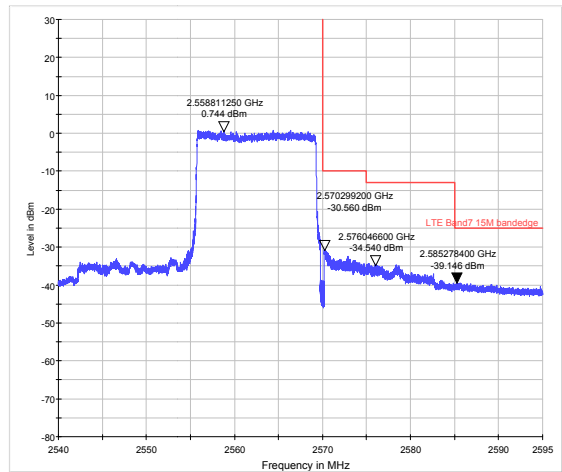

LTE Band 7 16QAM 20MHz CH-Low, 1 RB

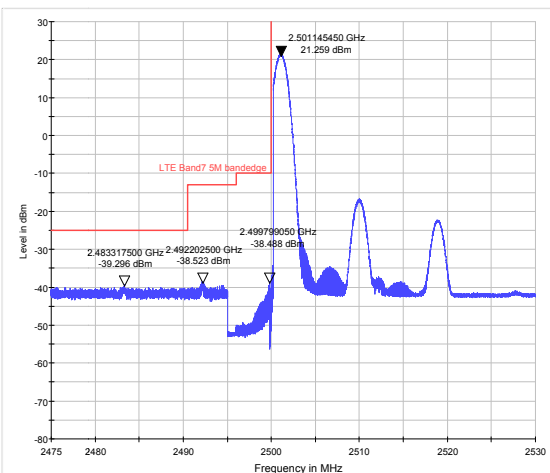

LTE Band 7 16QAM 20MHz CH-High, 1 RB

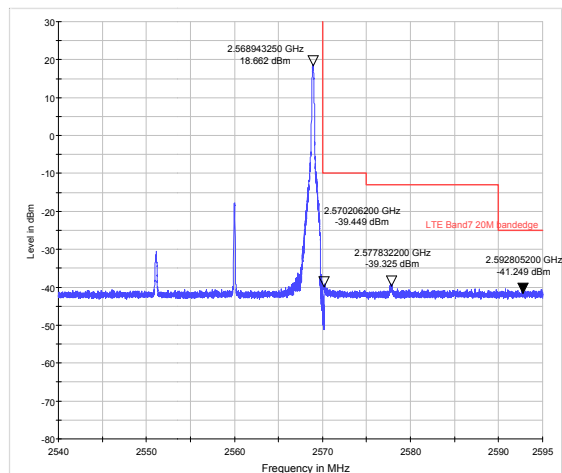



LTE Band 7 16QAM 20MHz CH-Low, 100%RB

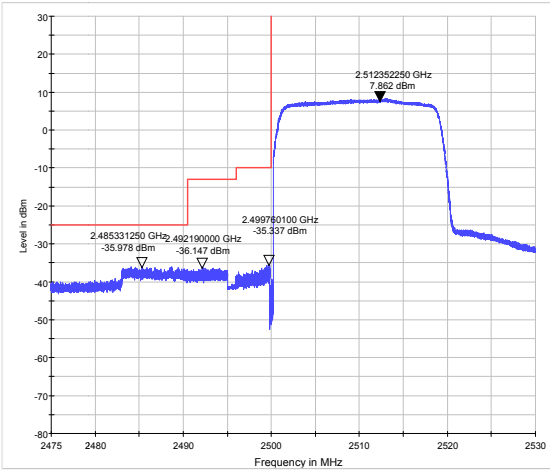

LTE Band 7 16QAM 20MHz CH-High, 100%RB

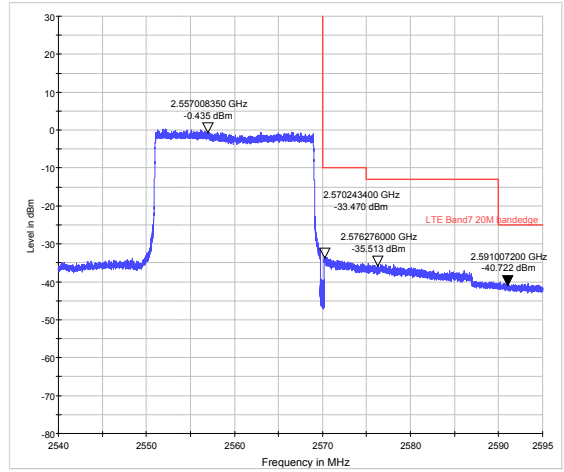

5.5 Peak-to-Average Power Ratio (PAPR)

Ambient condition

Temperature	Relative humidity	Pressure
23°C ~25°C	45%~50%	101.5kPa

Methods of Measurement

Measure the total peak power and record as Ppk. And measure the total average power and record as PAvg. Both the peak and average power levels must be expressed in the same logarithmic units (e.g., dBm). Determine the PAPR from:

$$PAPR (dB) = Ppk (dBm) - PAvg (dBm).$$

Test Setup

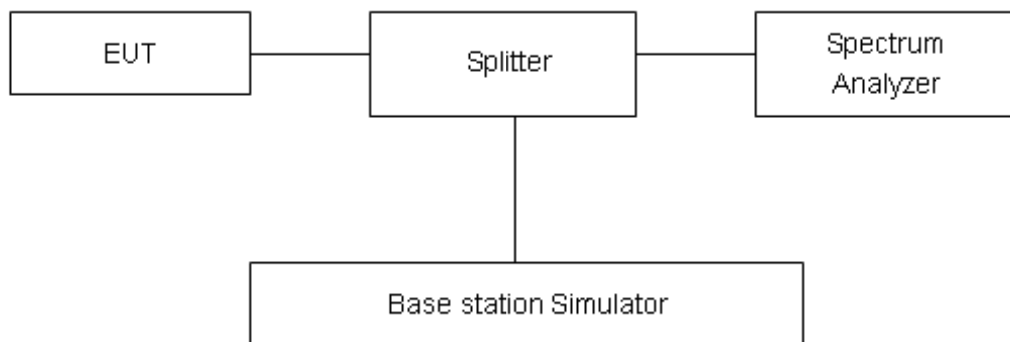

Limits

Rule Part 27.50(d)(5) Equipment employed must be authorized in accordance with the provisions of 24.51. Power measurements for transmissions by stations authorized under this section may be made either in accordance with a Commission-approved average power technique or in compliance with paragraph (d)(6) of this section. In measuring transmissions in this band using an average power technique, the peak-to-average ratio (PAR) of the transmission may not exceed 13 dB.

Measurement Uncertainty

The assessed measurement uncertainty to ensure 95% confidence level for the normal distribution is with the coverage factor k = 2, U= 0.4 dB.

Test Results

LTE Band 7								
Modulation	Bandwidth (MHz)	Channel	Frequency (MHz)	Peak (dBm)	Avg (dBm)	PAPR (dB)	Limit (dB)	Conclusion
QPSK	5	20775	2502.5	26.52	21.52	5.00	≤13	PASS
		21100	2535	26.60	21.78	4.82	≤13	PASS
		21425	2567.5	26.56	21.94	4.62	≤13	PASS
	10	20800	2505	26.58	21.60	4.98	≤13	PASS
		21100	2535	26.59	21.80	4.79	≤13	PASS
		21400	2565	26.57	21.98	4.59	≤13	PASS
	15	20825	2507.5	26.53	21.58	4.95	≤13	PASS
		21100	2535	26.52	21.76	4.76	≤13	PASS
		21375	2562.5	26.52	21.93	4.59	≤13	PASS
	20	20850	2510	26.38	21.55	4.83	≤13	PASS
		21100	2535	26.46	21.71	4.75	≤13	PASS
		21350	2560	26.49	21.89	4.60	≤13	PASS
16QAM	5	20775	2502.5	26.45	20.65	5.80	≤13	PASS
		21100	2535	26.51	20.85	5.66	≤13	PASS
		21425	2567.5	26.39	20.94	5.45	≤13	PASS
	10	20800	2505	26.49	20.68	5.81	≤13	PASS
		21100	2535	26.50	20.90	5.60	≤13	PASS
		21400	2565	26.46	20.98	5.48	≤13	PASS
	15	20825	2507.5	26.38	20.65	5.73	≤13	PASS
		21100	2535	26.35	20.85	5.50	≤13	PASS
		21375	2562.5	26.34	20.94	5.40	≤13	PASS
	20	20850	2510	26.32	20.63	5.69	≤13	PASS
		21100	2535	26.34	20.81	5.53	≤13	PASS
		21350	2560	26.38	20.91	5.47	≤13	PASS

5.6 Frequency Stability

Ambient condition

Temperature	Relative humidity	Pressure
23°C ~25°C	45%~50%	101.5kPa

Method of Measurement

1. Frequency Stability (Temperature Variation)

The temperature inside the climate chamber is varied from -30°C to +55°C in 10°C step size.

(1)With all power removed, the temperature was decreased to -10°C and permitted to stabilize for three hours.

(2)Measure the carrier frequency with the test equipment in a “call mode”. These measurements should be made within 1 minute of powering up the mobile station, to prevent significant self warming.

(3) Repeat the above measurements at 10°C increments from -30°C to +55°C. Allow at least 1.5 hours at each temperature, un-powered, before making measurements.

2. Frequency Stability (Voltage Variation)

The frequency stability shall be measured with variation of primary supply voltage as follows:

(1) Vary primary supply voltage from 85 to 115 percent of the nominal value for other than hand carried battery equipment.

(2) For hand carried, battery powered equipment, reduce primary supply voltage to the battery-operating end point which shall be specified by the manufacturer.

This transceiver is specified to operate with an input voltage of between 3.6 V and 4.4V, with a nominal voltage of 3.85V.

Test setup

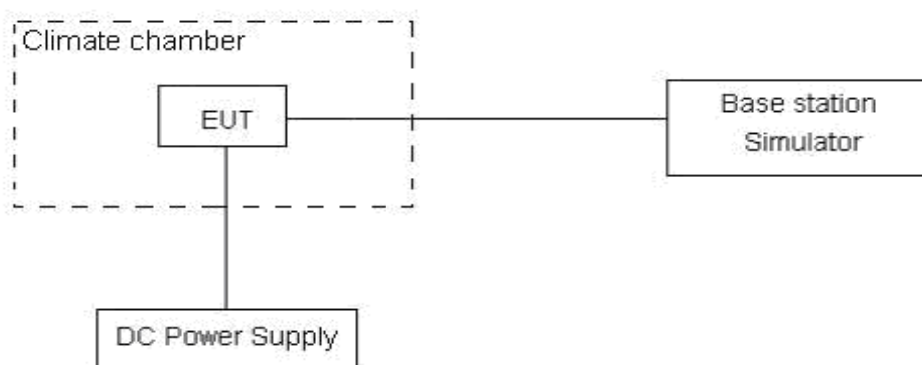

Limits

No specific frequency stability requirements in part 27.54

Measurement Uncertainty

The assessed measurement uncertainty to ensure 99.75% confidence level for the normal distribution is with the coverage factor $k = 3, U=0.01\text{ppm}$.

Test Result

Bandwidth	Test status	LTE Band 7 Channel 21100 Test Results (ppm)	
		QPSK	16QAM
5MHz	-30°C/Normal Voltage	-0.00181	0.00244
	-20°C/Normal Voltage	0.00032	0.00258
	-10°C/Normal Voltage	-0.00090	0.00278
	0°C/Normal Voltage	-0.00066	0.00249
	10°C/Normal Voltage	-0.00144	-0.00232
	20°C/Normal Voltage	-0.00243	-0.00239
	30°C/Normal Voltage	-0.00079	0.00441
	40°C/Normal Voltage	0.00012	0.00087
	50°C/Normal Voltage	-0.00098	0.00055
	55°C/Normal Voltage	-0.00125	0.00142
	20°C/Min Voltage	-0.00076	-0.00217
	20°C/Max Voltage	-0.00053	0.00524
10MHz	-30°C/Normal Voltage	-0.00066	-0.00241
	-20°C/Normal Voltage	-0.00045	-0.00336
	-10°C/Normal Voltage	-0.00070	-0.00153
	0°C/Normal Voltage	-0.00084	-0.00215
	10°C/Normal Voltage	-0.00101	-0.00367
	20°C/Normal Voltage	-0.00029	-0.00149
	30°C/Normal Voltage	-0.00236	-0.00342
	40°C/Normal Voltage	-0.00102	-0.00265
	50°C/Normal Voltage	-0.00144	-0.00190
	55°C/Normal Voltage	-0.00230	-0.00296
	20°C/Min Voltage	-0.00171	-0.00179
	20°C/Max Voltage	-0.00078	-0.00084
15MHz	-30°C/Normal Voltage	-0.00061	-0.00089
	-20°C/Normal Voltage	-0.00059	-0.00245
	-10°C/Normal Voltage	-0.00280	-0.00262
	0°C/Normal Voltage	-0.00097	-0.00156
	10°C/Normal Voltage	-0.00243	-0.00041
	20°C/Normal Voltage	-0.00097	-0.00149
	30°C/Normal Voltage	-0.00145	-0.00295
	40°C/Normal Voltage	0.00038	-0.00162
	50°C/Normal Voltage	0.00204	-0.00159
	55°C/Normal Voltage	-0.00012	-0.00138
	20°C/Min Voltage	0.00003	-0.00111
	20°C/Max Voltage	0.00065	-0.00165



20MHz	-30°C/Normal Voltage	-0.00041	-0.00006
	-20°C/Normal Voltage	-0.00046	0.00071
	-10°C/Normal Voltage	-0.00244	-0.00084
	0°C/Normal Voltage	-0.00200	-0.00112
	10°C/Normal Voltage	-0.00219	-0.00093
	20°C/Normal Voltage	-0.00109	-0.00269
	30°C/Normal Voltage	-0.00163	-0.00166
	40°C/Normal Voltage	0.00043	-0.00172
	50°C/Normal Voltage	0.00081	-0.00043
	55°C/Normal Voltage	-0.00113	-0.00237
	20°C/Min Voltage	-0.00121	-0.00215
	20°C/Max Voltage	-0.00222	-0.00132

5.7 Spurious Emissions at Antenna Terminals

Ambient condition

Temperature	Relative humidity	Pressure
23°C ~25°C	45%~50%	101.5kPa

Method of Measurement

The EUT was connected to Spectrum Analyzer and Base Station Simulator via power Splitter. The measurement is carried out using a spectrum analyzer. The spectrum analyzer scans from 30MHz to the 10th harmonic of the carrier. The peak detector is used. Set RBW 1MHz and VBW 3MHz, Sweep is set to ATUO.

Of those disturbances below (limit – 20 dB), the mark is not required for the EUT.

Test setup

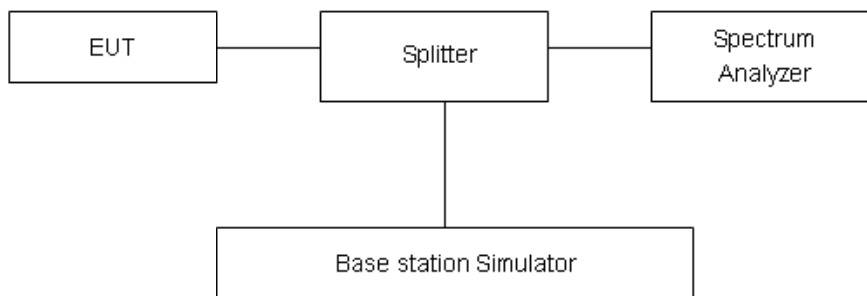

Limits

Rule Part 27.53(m) 55 + 10 log (P) dB on all frequencies more than X megahertz from the channel edge, where X is the greater of 6 megahertz or the actual emission bandwidth as defined in paragraph (m)(4) of this section.

Limit	-25 dBm
-------	---------

Measurement Uncertainty

The assessed measurement uncertainty to ensure 99.75% confidence level for the normal distribution is with the coverage factor $k = 1.96$.

Frequency	Uncertainty
100kHz-2GHz	0.684 dB
2GHz-18GHz	1.407 dB

Test Result

Sweep from 9 kHz to 30MHz, and the emissions more than 20 dB below the permissible value are not reported.

If disturbances were found more than 20dB below limit line, the mark is not required for the EUT. The signal beyond the limit is carrier.

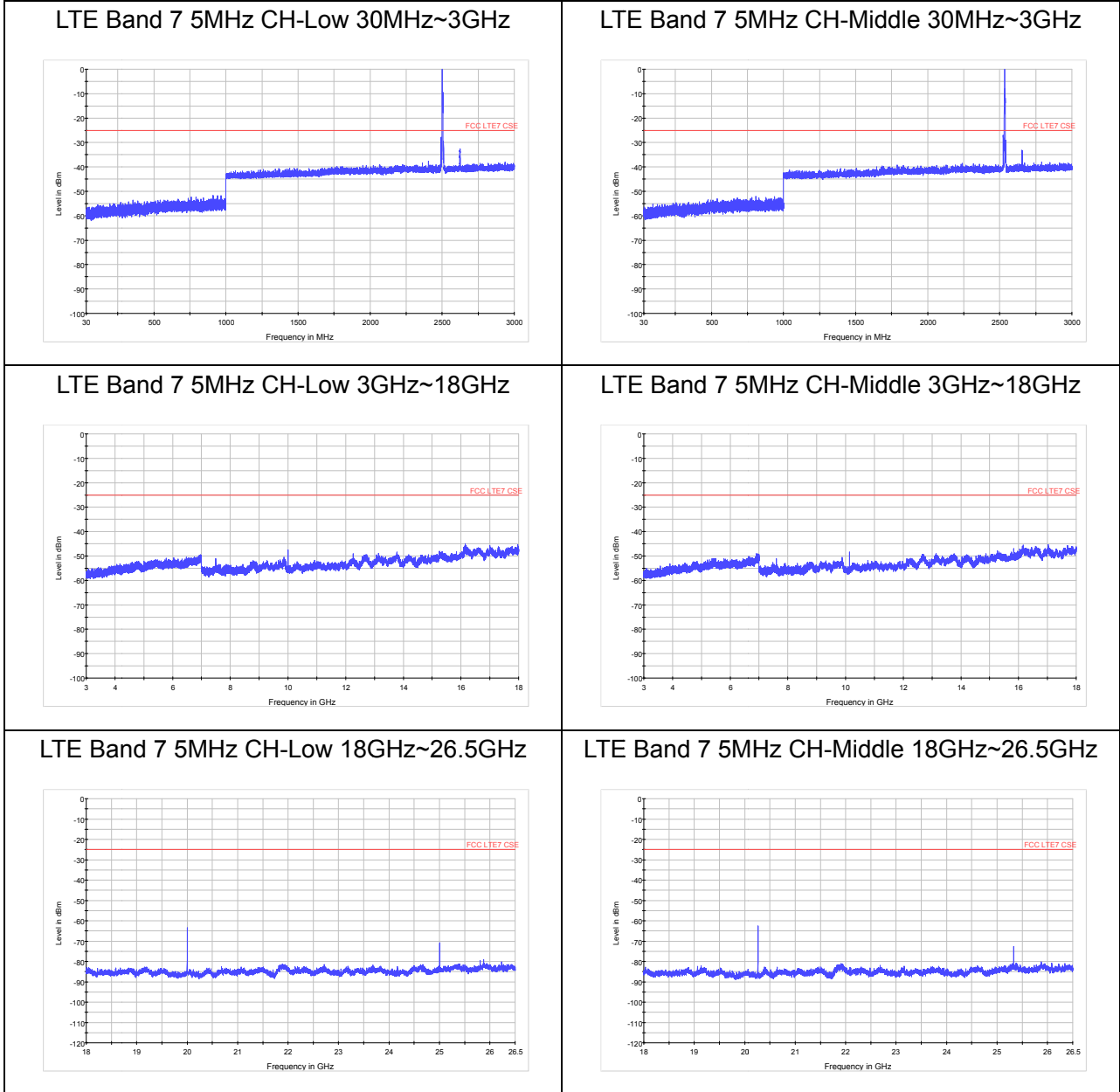



LTE Band 7 5MHz CH-High 30MHz~3GHz

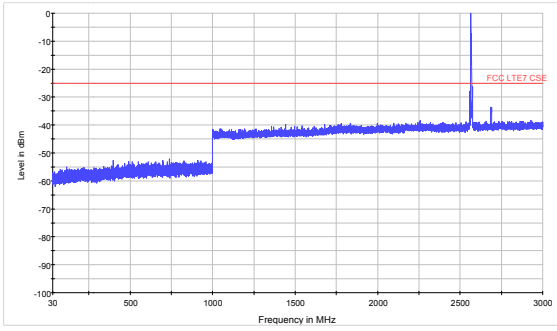

LTE Band 7 10MHz CH-Low 30MHz~3GHz

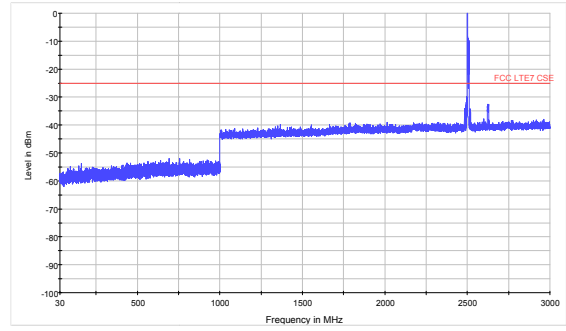

LTE Band 7 5MHz CH-High 3GHz~18GHz

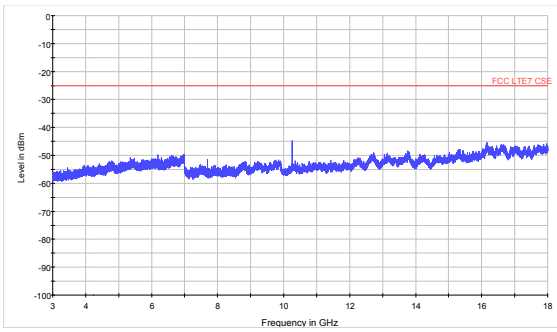

LTE Band 7 10MHz CH-Low 3GHz~18GHz

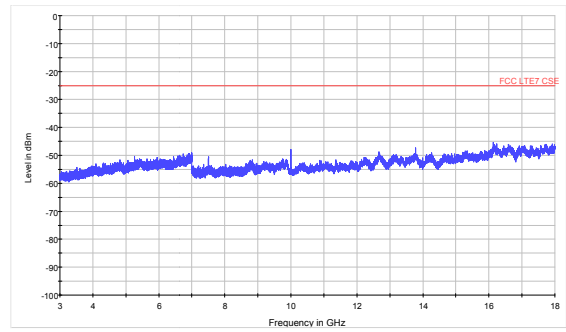

LTE Band 7 5MHz CH-High 18GHz~26.5GHz

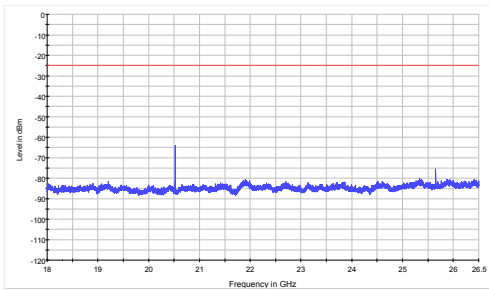

LTE Band 7 10MHz C CH-Low 18GHz~26.5GHz

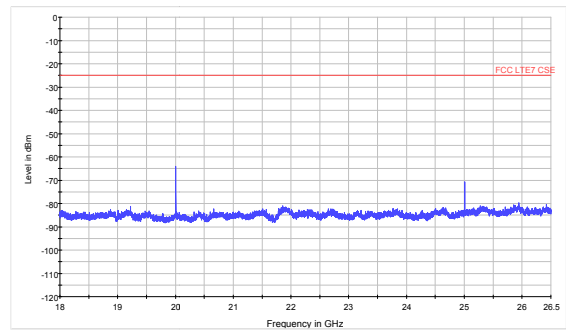



LTE Band 7 10MHz CH-Middle 30MHz~3GHz

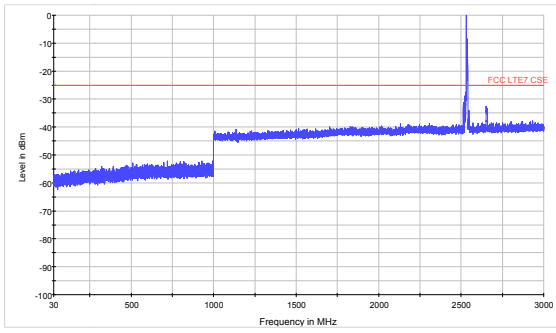

LTE Band 7 10MHz CH-High 30MHz~3GHz

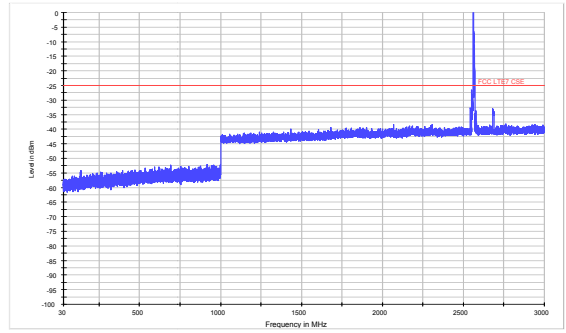

LTE Band 7 10MHz CH-Middle 3GHz~18GHz

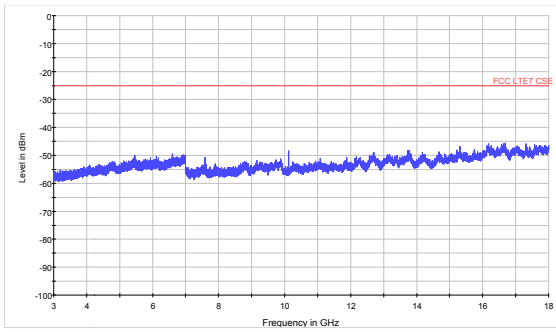

LTE Band 7 10MHz CH-High 3GHz~18GHz

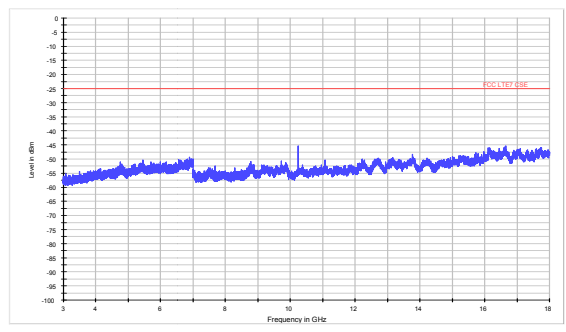

LTE Band 7 10MHz CH-Middle 18GHz~26.5GHz

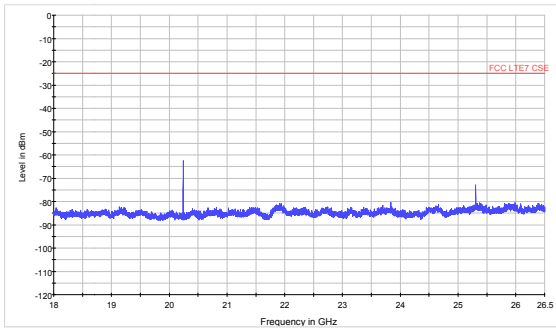

LTE Band 7 10MHz CH-High 18GHz~26.5GHz

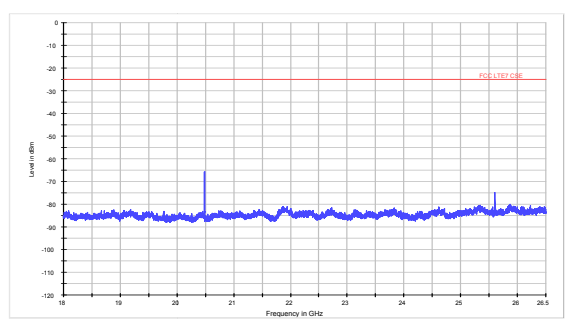



LTE Band 7 15MHz CH-Low 30MHz~3GHz

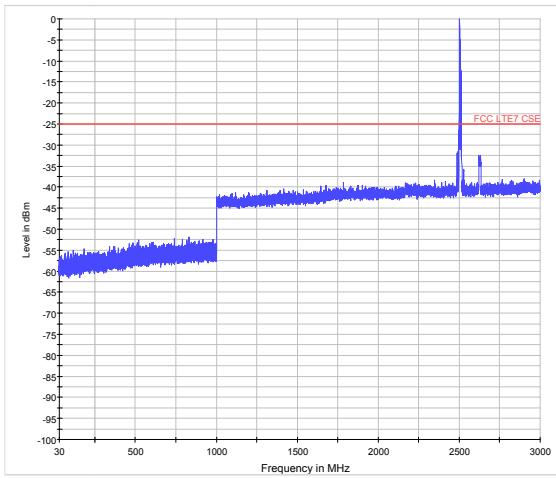

LTE Band 7 15MHz CH-Middle 30MHz~3GHz

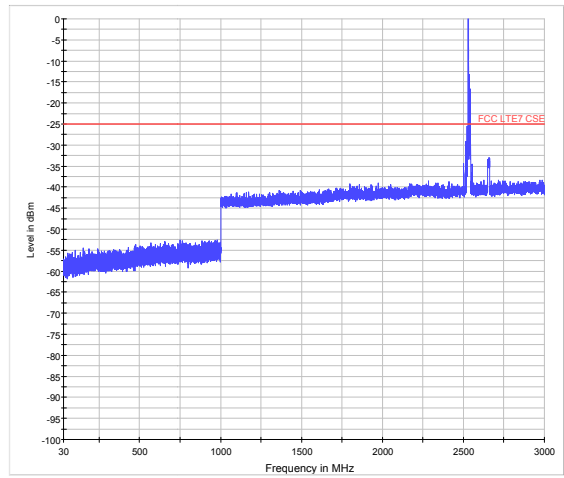

LTE Band 7 15MHz CH-Low 3GHz~18GHz

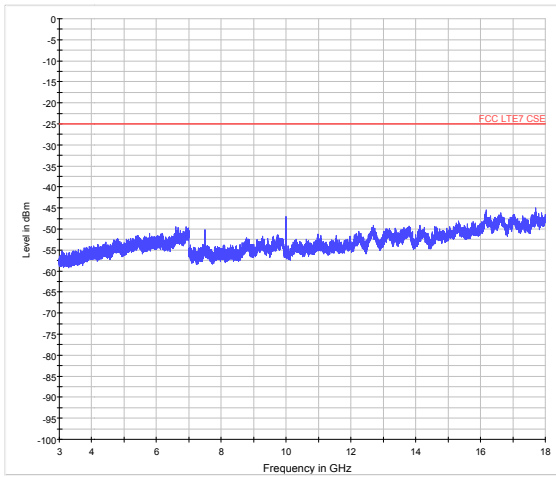

LTE Band 7 15MHz CH-Middle 3GHz~18GHz

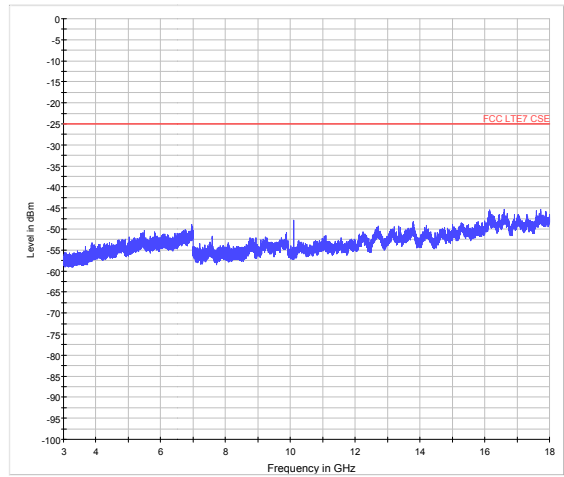

LTE Band 7 15MHz CH-Low 18GHz~26.5GHz

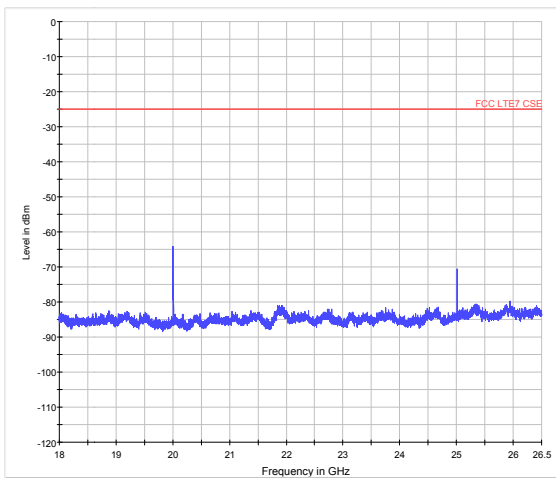

LTE Band 7 15MHz CH-Middle 18GHz~26.5GHz

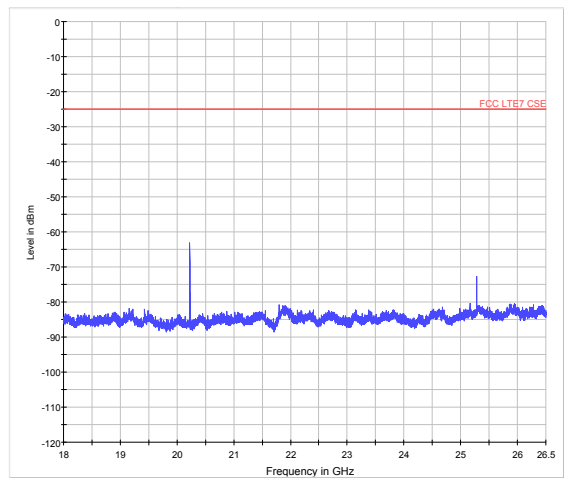



LTE Band 7 15MHz CH-High 30MHz~3GHz

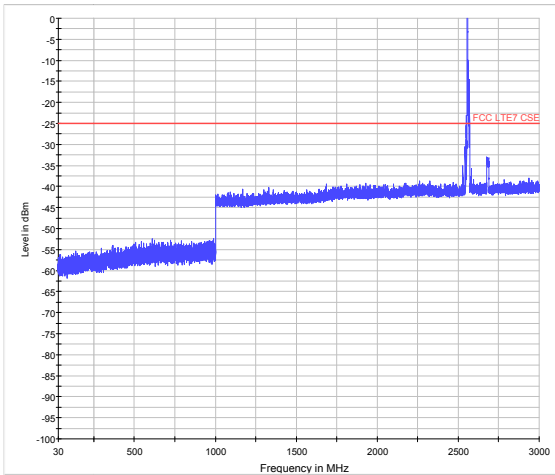

LTE Band 7 20MHz CH-Low 30MHz~3GHz

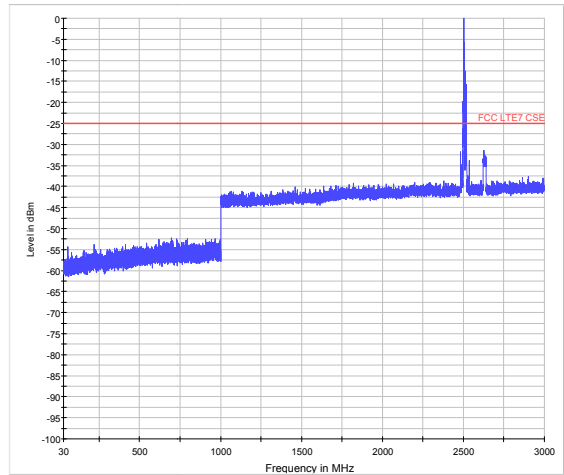

LTE Band 7 15MHz CH-High 3GHz~18GHz

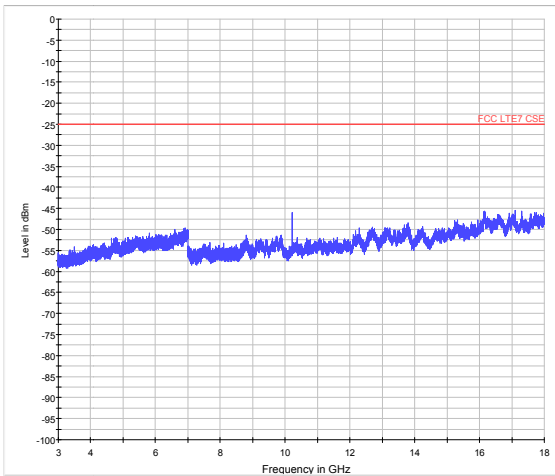

LTE Band 7 20MHz CH-Low 3GHz~18GHz

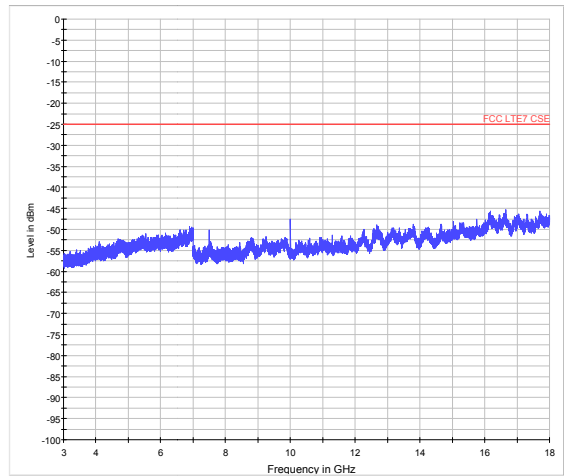

LTE Band 7 15MHz CH-High 18GHz~26.5GHz

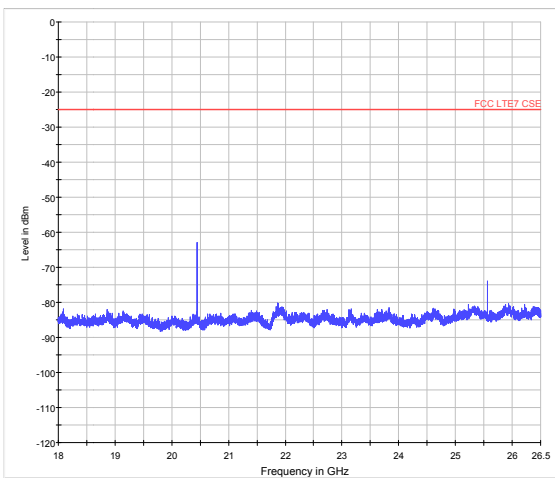

LTE Band 7 20MHz CH-Low 18GHz~26.5GHz

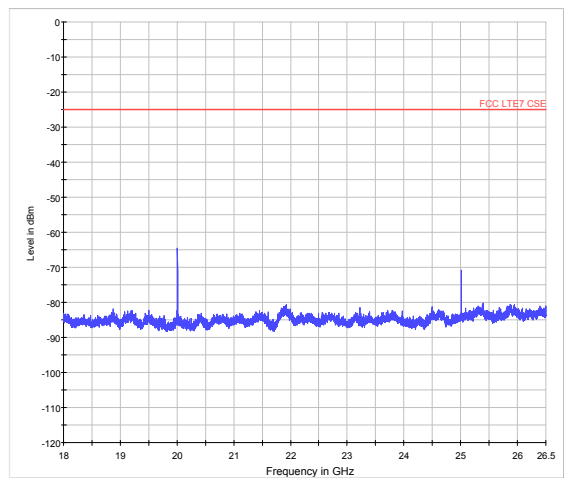



LTE Band 7 20MHz CH-Middle 30MHz~3GHz

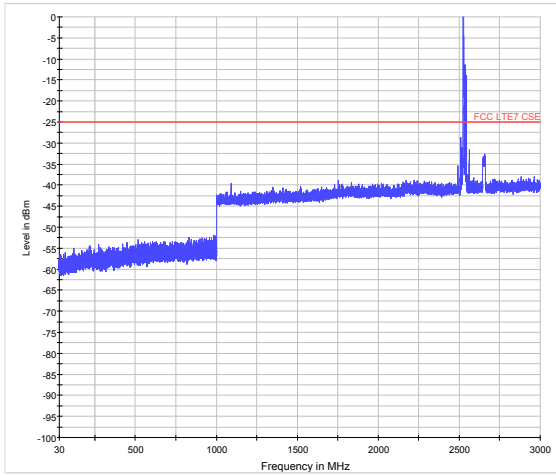

LTE Band 7 20MHz CH-High 30MHz~3GHz

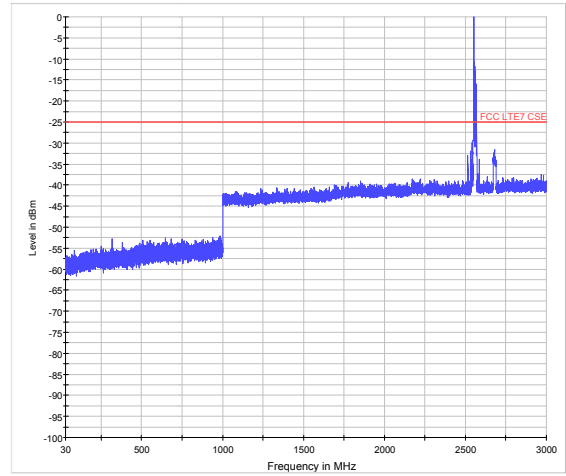

LTE Band 7 20MHz CH-Middle 3GHz~18GHz

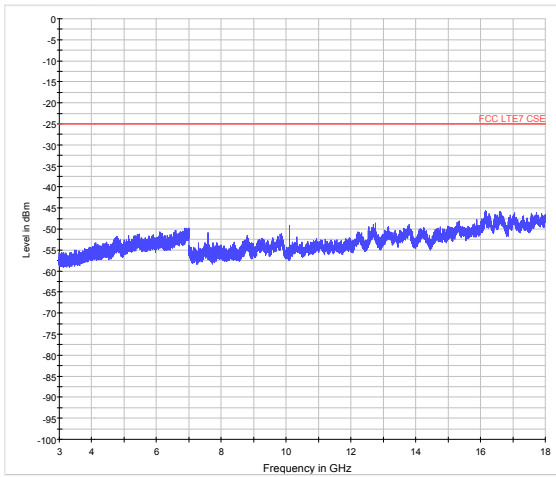

LTE Band 7 20MHz CH-High 3GHz~18GHz

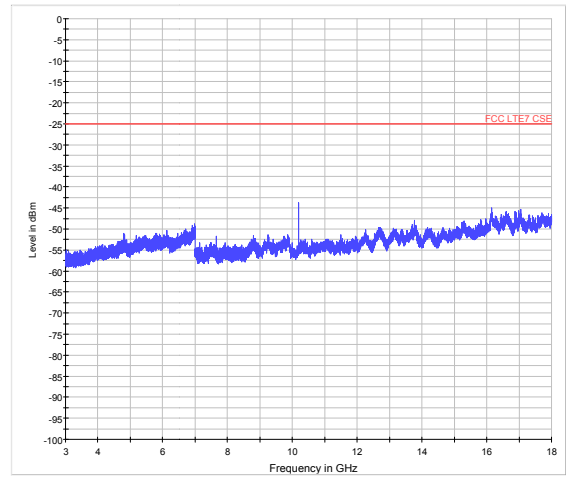

LTE Band 7 20MHz CH-Middle 18GHz~26.5GHz

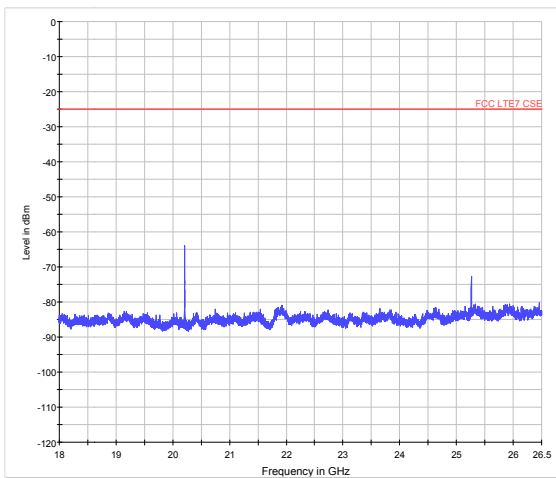

LTE Band 7 20MHz CH-High 18GHz~26.5GHz

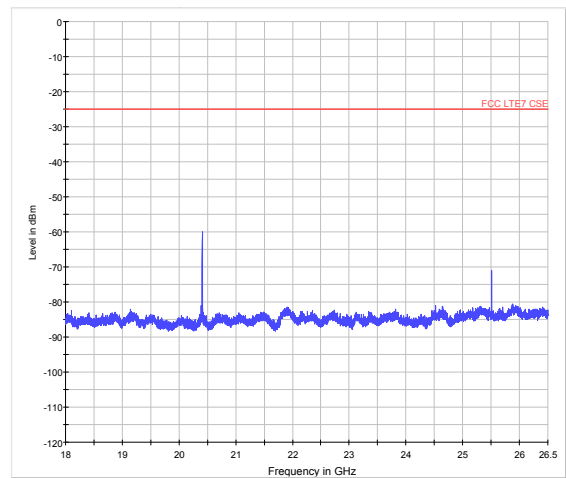



If disturbances were found more than 20dB below limit line, the mark is not required for the EUT.
The signal beyond the limit is carrier in the following plots.

Test Data File Name	Frequency (MHz)	Level (dBm)	Limit (dBm)	Margin (dB)
LTE B7_CHHIGH_5M_RB1_3-18GHz	10261.1	-44.87	-25.00	19.87
LTE B7_CHHIGH_20M_RB1_3-18GHz	10203.8	-43.76	-25.00	18.76

5.8 Radiates Spurious Emission

Ambient condition

Temperature	Relative humidity	Pressure
23°C ~25°C	45%~50%	101.5kPa

Method of Measurement

- The testing follows FCC KDB 971168 v03 Section 5.8 and ANSI/TIA-603-D-2010.
- The EUT is placed on a turntable 0.8 meters above the ground in the chamber, 3 meter away from the antenna. The maximal emission value is acquired by adjusting the antenna height, polarisation and turntable azimuth. Normally, the height range of antenna is 1 m to 4 m, the azimuth range of turntable is 0° to 360°, and the receive antenna has two polarizations Vertical (V) and Horizontal (H).
- A log-periodic antenna or double-ridged waveguide horn antenna shall be substituted in place of the EUT. The log-periodic antenna will be driven by a signal generator and the level will be adjusted till the same power value on the spectrum analyzer or receiver. The level of the spurious emissions can be calculated through the level of the signal generator, cable loss, the gain of the substitution antenna and the reading of the spectrum analyzer or receiver.
- The EUT is then put into continuously transmitting mode at its maximum power level during the test. Set Test Receiver or Spectrum RBW=1MHz, VBW=3MHz, And the maximum value of the receiver should be recorded as (Pr).
- The EUT shall be replaced by a substitution antenna. In the chamber, an substitution antenna for the frequency band of interest is placed at the reference point of the chamber. An RF Signal source for the frequency band of interest is connected to the substitution antenna with a cable that has been constructed to not interfere with the radiation pattern of the antenna. A power (PMea) is applied to the input of the substitution antenna, and adjust the level of the signal generator output until the value of the receiver reach the previously recorded (Pr). The power of signal source (PMea) is recorded. The test should be performed by rotating the test item and adjusting the receiving antenna polarization.
- A amplifier should be connected to the Signal Source output port. And the cable should be connect between the Amplifier and the Substitution Antenna. The cable loss (Pcl) ,the Substitution Antenna Gain (Ga) and the Amplifier Gain (PAg) should be recorded after test.
- The measurement results are obtained as described below:

$$\text{Power(EIRP)} = \text{PMea} - \text{PAg} - \text{Pcl} + \text{Ga}$$
The measurement results are amend as described below:

$$\text{Power(EIRP)} = \text{PMea} - \text{Pcl} + \text{Ga}$$
- This value is EIRP since the measurement is calibrated using an antenna of known gain (2.15 dBi) and known input power. ERP can be calculated from EIRP by subtracting the gain of the dipole, $\text{ERP} = \text{EIRP} - 2.15\text{dBi}$.

Test setup

30MHz~~~ 1GHz

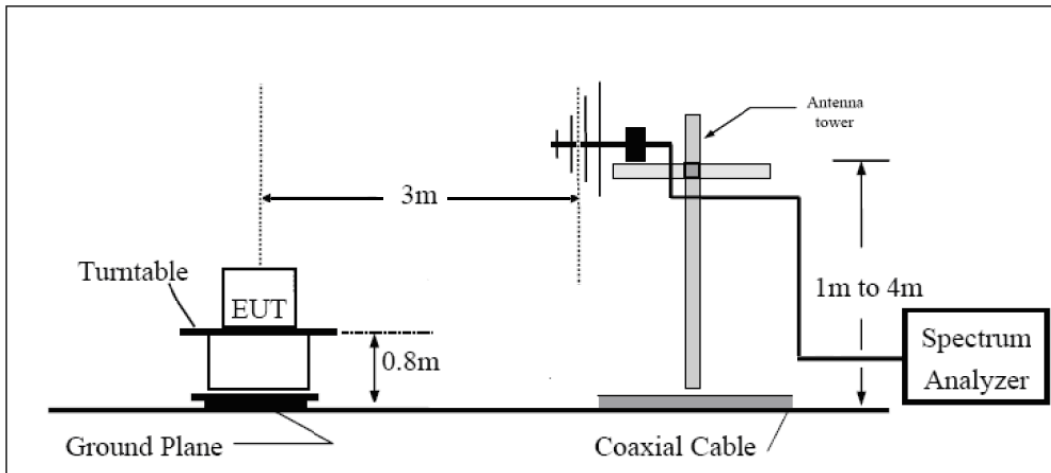

Above 1GHz

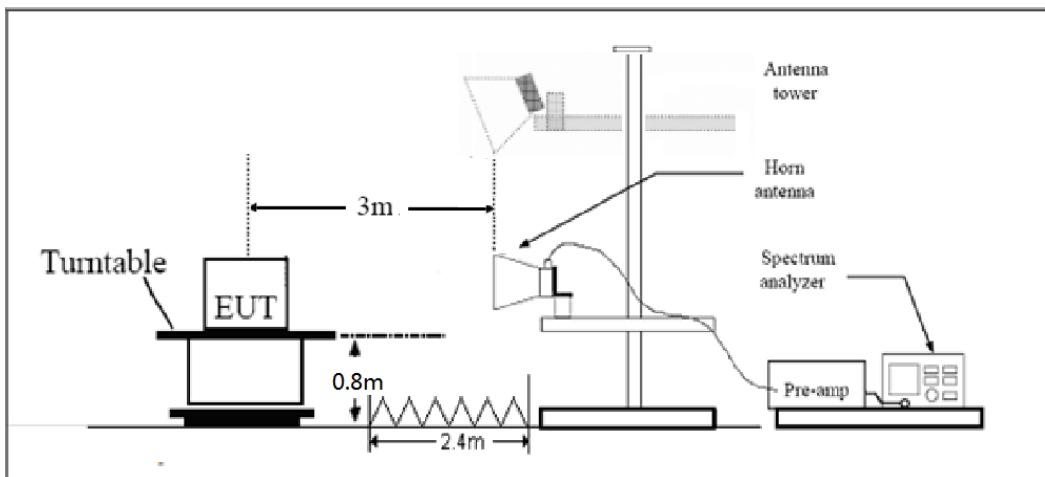

Note: Area side:2.4mX3.6m

The radiated emission was measured in the following position: EUT stand-up position (Z axis), lie-down position (X, Y axis). The worst emission was found in stand-up position (Z axis) and the worst case was recorded.

Limits

Rule Part 27.53(m) 55 + 10 log (P) dB on all frequencies more than X megahertz from the channel edge, where X is the greater of 6 megahertz or the actual emission bandwidth as defined in paragraph (m)(4) of this section.

Limit	-25 dBm
-------	---------

Measurement Uncertainty

The assessed measurement uncertainty to ensure 95% confidence level for the normal distribution is with the coverage factor $k = \pm 1.96$, $U = \pm 3.55$ dB.

Test Result

LTE Band 7 QPSK 5MHz CH-Low, RB 1

Harmonic	Frequency (MHz)	SG (dBm)	Cable Loss (dB)	Gain (dBi)	Antenna Polarization	EIRP Level (dBm)	Limit (dBm)	Margin (dB)	Azimuth (deg)
2	5005.0	-47.55	2.00	9.15	Horizontal	-40.4	-25.0	15.4	180
3	7507.5	-49.95	2.50	11.35	Horizontal	-41.1	-25.0	16.1	225
4	10010.0	-47.25	4.20	12.05	Horizontal	-39.4	-25.0	14.4	45
5	12512.5	-46.05	5.20	12.85	Horizontal	-38.4	-25.0	13.4	180
6	15015.0	-46.53	5.50	14.23	Horizontal	-37.8	-25.0	12.8	270
7	17517.5	-43.75	5.70	14.15	Horizontal	-35.3	-25.0	10.3	135
8	20020.0	-42.16	6.30	13.76	Horizontal	-34.7	-25.0	9.7	180
9	22522.5	-40.95	6.80	14.05	Horizontal	-33.7	-25.0	8.7	225
10	25025.0	-40.74	6.90	14.84	Horizontal	-32.8	-25.0	7.8	90

Note: 1.The other Spurious RF Radiated emissions level is no more than noise floor.
 2. The worst emission was found in the antenna is Horizontal position.

LTE Band 7 QPSK 5MHz CH-Middle, RB 1

Harmonic	Frequency (MHz)	SG (dBm)	Cable Loss (dB)	Gain (dBi)	Antenna Polarization	EIRP Level (dBm)	Limit (dBm)	Margin (dB)	Azimuth (deg)
2	5070.0	-43.25	2.00	9.15	Horizontal	-36.1	-25.0	11.1	135
3	7605.0	-49.95	2.50	11.35	Horizontal	-41.1	-25.0	16.1	180
4	10140.0	-47.05	4.20	12.05	Horizontal	-39.2	-25.0	14.2	90
5	12675.0	-44.95	5.20	12.85	Horizontal	-37.3	-25.0	12.3	45
6	15210.0	-46.53	5.50	14.23	Horizontal	-37.8	-25.0	12.8	180
7	17745.0	-43.75	5.70	14.15	Horizontal	-35.3	-25.0	10.3	270
8	20280.0	-42.26	6.30	13.76	Horizontal	-34.8	-25.0	9.8	45
9	22815.0	-41.35	6.80	14.05	Horizontal	-34.1	-25.0	9.1	180
10	25350.0	-41.64	6.90	14.84	Horizontal	-33.7	-25.0	9.8	225

Note: 1.The other Spurious RF Radiated emissions level is no more than noise floor.
 2. The worst emission was found in the antenna is Horizontal position.

LTE Band 7 QPSK 5MHz CH-High, RB 1

Harmonic	Frequency (MHz)	SG (dBm)	Cable Loss (dB)	Gain (dBi)	Antenna Polarization	EIRP Level (dBm)	Limit (dBm)	Margin (dB)	Azimuth (deg)
2	5135.0	-43.95	2.00	9.15	Horizontal	-36.8	-25.0	11.8	225
3	7702.5	-49.95	2.50	11.35	Horizontal	-41.1	-25.0	16.1	45
4	10270.0	-46.95	4.20	12.05	Horizontal	-39.1	-25.0	14.1	90
5	12837.5	-44.95	5.20	12.85	Horizontal	-37.3	-25.0	12.3	180
6	15405.0	-45.03	5.50	14.23	Horizontal	-36.3	-25.0	11.3	180
7	17972.5	-43.55	5.70	14.15	Horizontal	-35.1	-25.0	10.1	270
8	20540.0	-42.16	6.30	13.76	Horizontal	-34.7	-25.0	9.7	135
9	23107.5	-40.45	6.80	14.05	Horizontal	-33.2	-25.0	8.2	180
10	25675.0	-40.34	6.90	14.84	Horizontal	-32.4	-25.0	7.4	225

Note: 1.The other Spurious RF Radiated emissions level is no more than noise floor.
2. The worst emission was found in the antenna is Horizontal position.

LTE Band 7 QPSK 10MHz CH-Low, RB 1

Harmonic	Frequency (MHz)	SG (dBm)	Cable Loss (dB)	Gain (dBi)	Antenna Polarization	EIRP Level (dBm)	Limit (dBm)	Margin (dB)	Azimuth (deg)
2	5010.0	-48.45	2.00	9.15	Horizontal	-41.3	-25.0	16.3	225
3	7515.0	-49.65	2.50	11.35	Horizontal	-40.8	-25.0	15.8	45
4	10020.0	-47.55	4.20	12.05	Horizontal	-39.7	-25.0	14.7	180
5	12525.0	-44.15	5.20	12.85	Horizontal	-36.5	-25.0	11.5	270
6	15030.0	-42.03	5.50	14.23	Horizontal	-33.3	-25.0	8.3	135
7	17535.0	-43.35	5.70	14.15	Horizontal	-34.9	-25.0	9.9	180
8	20040.0	-43.26	6.30	13.76	Horizontal	-35.8	-25.0	10.8	225
9	22545.0	-41.45	6.80	14.05	Horizontal	-34.2	-25.0	9.2	90
10	25050.0	-41.24	6.90	14.84	Horizontal	-33.3	-25.0	8.3	135

Note: 1.The other Spurious RF Radiated emissions level is no more than noise floor.
2. The worst emission was found in the antenna is Horizontal position.

LTE Band 7 QPSK 10MHz CH-Middle, RB 1

Harmonic	Frequency (MHz)	SG (dBm)	Cable Loss (dB)	Gain (dBi)	Antenna Polarization	EIRP Level (dBm)	Limit (dBm)	Margin (dB)	Azimuth (deg)
2	5070.0	-48.45	2.00	9.15	Horizontal	-41.3	-25.0	16.3	45
3	7605.0	-49.15	2.50	11.35	Horizontal	-40.3	-25.0	15.3	180
4	10140.0	-46.55	4.20	12.05	Horizontal	-38.7	-25.0	13.7	270
5	12675.0	-43.85	5.20	12.85	Horizontal	-36.2	-25.0	11.2	135
6	15210.0	-41.63	5.50	14.23	Horizontal	-32.9	-25.0	7.9	180
7	17745.0	-42.55	5.70	14.15	Horizontal	-34.1	-25.0	9.1	225
8	20280.0	-41.96	6.30	13.76	Horizontal	-34.5	-25.0	9.5	45
9	22815.0	-41.05	6.80	14.05	Horizontal	-33.8	-25.0	8.8	90
10	25350.0	-40.34	6.90	14.84	Horizontal	-32.4	-25.0	7.4	180

Note: 1.The other Spurious RF Radiated emissions level is no more than noise floor.
2. The worst emission was found in the antenna is Horizontal position.

LTE Band 7 QPSK 10MHz CH-High, RB 1

Harmonic	Frequency (MHz)	SG (dBm)	Cable Loss (dB)	Gain (dBi)	Antenna Polarization	EIRP Level (dBm)	Limit (dBm)	Margin (dB)	Azimuth (deg)
2	5130.0	-46.55	2.00	10.15	Horizontal	-38.4	-25.0	13.4	45
3	7695.0	-49.15	2.50	11.35	Horizontal	-40.3	-25.0	15.3	180
4	10260.0	29.45	4.20	12.05	Horizontal	-37.3	-25.0	-62.3	225
5	12825.0	-46.05	5.20	14.85	Horizontal	-36.4	-25.0	11.4	45
6	15390.0	-40.83	5.50	13.23	Horizontal	-33.1	-25.0	8.1	90
7	17955.0	-41.15	5.70	12.15	Horizontal	-34.7	-25.0	9.7	180
8	20520.0	-42.26	6.30	13.76	Horizontal	-34.8	-25.0	9.8	270
9	23085.0	-41.15	6.80	14.05	Horizontal	-33.9	-25.0	8.9	180
10	25650.0	-41.34	6.90	14.84	Horizontal	-33.4	-25.0	8.4	270

Note: 1.The other Spurious RF Radiated emissions level is no more than noise floor.
2. The worst emission was found in the antenna is Horizontal position.

LTE Band 7 QPSK 15MHz CH-Low, RB 1

Harmonic	Frequency (MHz)	SG (dBm)	Cable Loss (dB)	Gain (dBi)	Antenna Polarization	EIRP Level (dBm)	Limit (dBm)	Margin (dB)	Azimuth (deg)
2	5015.0	-47.65	2.00	10.15	Horizontal	-39.5	-25.0	14.5	270
3	7522.5	-49.65	2.50	11.35	Horizontal	-40.8	-25.0	15.8	135
4	10030.0	-45.25	4.20	12.05	Horizontal	-37.4	-25.0	12.4	180
5	12537.5	-45.55	5.20	14.85	Horizontal	-35.9	-25.0	10.9	225
6	15045.0	-41.53	5.50	13.23	Horizontal	-33.8	-25.0	8.8	45
7	17552.5	-38.55	5.70	12.15	Horizontal	-32.1	-25.0	7.1	90
8	20060.0	-41.96	6.30	13.76	Horizontal	-34.5	-25.0	9.5	180
9	22567.5	-40.65	6.80	14.05	Horizontal	-33.4	-25.0	8.4	270
10	25075.0	-40.24	6.90	14.84	Horizontal	-32.3	-25.0	7.3	135

Note: 1.The other Spurious RF Radiated emissions level is no more than noise floor.
2. The worst emission was found in the antenna is Horizontal position.

LTE Band 7 QPSK 15MHz CH-Middle, RB 1

Harmonic	Frequency (MHz)	SG (dBm)	Cable Loss (dB)	Gain (dBi)	Antenna Polarization	EIRP Level (dBm)	Limit (dBm)	Margin (dB)	Azimuth (deg)
2	5070.0	-49.75	2.00	10.15	Horizontal	-41.6	-25.0	16.6	180
3	7605.0	-49.95	2.50	11.35	Horizontal	-41.1	-25.0	16.1	270
4	10140.0	-45.45	4.20	12.05	Horizontal	-37.6	-25.0	12.6	135
5	12675.0	-45.55	5.20	14.85	Horizontal	-35.9	-25.0	10.9	180
6	15210.0	-41.53	5.50	13.23	Horizontal	-33.8	-25.0	8.8	225
7	17745.0	-39.15	5.70	12.15	Horizontal	-32.7	-25.0	7.7	45
8	20280.0	-43.06	6.30	13.76	Horizontal	-35.6	-25.0	10.6	180
9	22815.0	-42.05	6.80	14.05	Horizontal	-34.8	-25.0	9.8	270
10	25350.0	-41.34	6.90	14.84	Horizontal	-33.4	-25.0	8.4	135

Note: 1.The other Spurious RF Radiated emissions level is no more than noise floor.
2. The worst emission was found in the antenna is Horizontal position.

LTE Band 7 QPSK 15MHz CH-High, RB 1

Harmonic	Frequency (MHz)	SG (dBm)	Cable Loss (dB)	Gain (dBi)	Antenna Polarization	EIRP Level (dBm)	Limit (dBm)	Margin (dB)	Azimuth (deg)
2	5125.0	-46.45	2.00	10.15	Horizontal	-38.3	-25.0	13.3	270
3	7687.5	-51.15	2.50	11.35	Horizontal	-42.3	-25.0	17.3	135
4	10250.0	-44.95	4.20	12.05	Horizontal	-37.1	-25.0	12.1	45
5	12812.5	-45.05	5.20	14.85	Horizontal	-35.4	-25.0	10.4	270
6	15375.0	-42.33	5.50	13.23	Horizontal	-34.6	-25.0	9.6	180
7	17937.5	-39.55	5.70	12.15	Horizontal	-33.1	-25.0	8.1	270
8	20500.0	-41.56	6.30	13.76	Horizontal	-34.1	-25.0	9.1	135
9	23062.5	-40.95	6.80	14.05	Horizontal	-33.7	-25.0	8.7	180
10	25625.0	-40.44	6.90	14.84	Horizontal	-32.5	-25.0	7.5	270

Note: 1.The other Spurious RF Radiated emissions level is no more than noise floor.
2. The worst emission was found in the antenna is Horizontal position.

LTE Band 7 QPSK 20MHz CH-Low, RB 1

Harmonic	Frequency (MHz)	SG (dBm)	Cable Loss (dB)	Gain (dBi)	Antenna Polarization	EIRP Level (dBm)	Limit (dBm)	Margin (dB)	Azimuth (deg)
2	5020.0	-49.55	2.00	10.15	Horizontal	-41.4	-25.0	16.4	270
3	7530.0	-49.35	2.50	11.35	Horizontal	-40.5	-25.0	15.5	180
4	10040.0	-46.15	4.20	12.05	Horizontal	-38.3	-25.0	13.3	270
5	12550.0	-46.35	5.20	14.85	Horizontal	-36.7	-25.0	11.7	135
6	15060.0	-43.53	5.50	13.23	Horizontal	-35.8	-25.0	10.8	180
7	17570.0	-40.05	5.70	12.15	Horizontal	-33.6	-25.0	8.6	270
8	20080.0	-41.26	6.30	13.76	Horizontal	-33.8	-25.0	8.8	135
9	22590.0	-40.45	6.80	14.05	Horizontal	-33.2	-25.0	8.2	45
10	25100.0	-40.24	6.90	14.84	Horizontal	-32.3	-25.0	7.3	270

Note: 1.The other Spurious RF Radiated emissions level is no more than noise floor.
2. The worst emission was found in the antenna is Horizontal position.

LTE Band 7 QPSK 20MHz CH-Middle, RB 1

Harmonic	Frequency (MHz)	SG (dBm)	Cable Loss (dB)	Gain (dBi)	Antenna Polarization	EIRP Level (dBm)	Limit (dBm)	Margin (dB)	Azimuth (deg)
2	5070.0	-47.85	2.00	10.15	Horizontal	-39.7	-25.0	14.7	270
3	7605.0	-49.65	2.50	11.35	Horizontal	-40.8	-25.0	15.8	135
4	10140.0	-45.65	4.20	12.05	Horizontal	-37.8	-25.0	12.8	45
5	12675.0	-44.95	5.20	14.85	Horizontal	-35.3	-25.0	10.3	270
6	15210.0	-42.63	5.50	13.23	Horizontal	-34.9	-25.0	9.9	180
7	17745.0	-39.65	5.70	12.15	Horizontal	-33.2	-25.0	8.2	270
8	20280.0	-43.46	6.30	13.76	Horizontal	-36.0	-25.0	11.0	135
9	22815.0	-42.65	6.80	14.05	Horizontal	-35.4	-25.0	10.4	45
10	25350.0	-42.64	6.90	14.84	Horizontal	-34.7	-25.0	9.7	180

Note: 1.The other Spurious RF Radiated emissions level is no more than noise floor.
 2. The worst emission was found in the antenna is Horizontal position.

LTE Band 7 QPSK 20MHz CH-High, RB 1

Harmonic	Frequency (MHz)	SG (dBm)	Cable Loss (dB)	Gain (dBi)	Antenna Polarization	EIRP Level (dBm)	Limit (dBm)	Margin (dB)	Azimuth (deg)
2	5120.0	-44.85	2.00	10.15	Horizontal	-36.7	-25.0	11.7	45
3	7680.0	-51.05	2.50	11.35	Horizontal	-42.2	-25.0	17.2	180
4	10240.0	-47.55	4.20	12.05	Horizontal	-39.7	-25.0	14.7	270
5	12800.0	-48.25	5.20	14.85	Horizontal	-38.6	-25.0	13.6	135
6	15360.0	-46.13	5.50	13.23	Horizontal	-38.4	-25.0	13.4	45
7	17920.0	-44.35	5.70	12.15	Horizontal	-37.9	-25.0	12.9	270
8	20480.0	-41.66	6.30	13.76	Horizontal	-34.2	-25.0	9.2	180
9	23040.0	-40.55	6.80	14.05	Horizontal	-33.3	-25.0	8.3	270
10	25600.0	-40.44	6.90	14.84	Horizontal	-32.5	-25.0	7.5	135

Note: 1.The other Spurious RF Radiated emissions level is no more than noise floor.
 2. The worst emission was found in the antenna is Horizontal position.

6 Main Test Instruments

Name	Manufacturer	Type	Serial Number	Calibration Date	Expiration Date
Base Station Simulator	R&S	CMW500	113645	2017-05-14	2018-05-13
Power Splitter	Hua Xiang	SHX-GF2-2-13	10120101	2017-05-14	2018-05-13
Spectrum Analyzer	Agilent	N9010A	MY47191109	2017-05-14	2018-05-13
Signal Analyzer	R&S	FSV30	100815	2016-12-16	2017-12-15
Signal generator	R&S	SMB 100A	102594	2017-05-14	2018-05-13
EMI Test Receiver	R&S	ESCI	100948	2017-05-20	2018-05-19
Trilog Antenna	SCHWARZBECK	VUBL 9163	9163-201	2014-12-06	2017-12-05
Horn Antenna	R&S	HF907	100126	2014-12-06	2017-12-05
Horn Antenna	ETS-Lindgren	3160-09	00102643	2015-01-30	2018-01-29
Climatic Chamber	Re Ce	PT-30B	20101891	2015-07-18	2018-07-17
RF Cable	Agilent	SMA 15cm	0001	2017-08-04	2018-02-03
Preamplifier	R&S	SCU18	102327	2017-06-18	2018-06-17
Software	R&S	EMC32	V 8.52.0	NA	NA

ANNEX A: EUT Appearance and Test Setup

A.1 EUT Appearance



Front Side



Back Side

For Single Screen Mode



Front Side



Back Side

**For Double Screen Mode
Picture 1 EUT and Accessory**

A.2 Test Setup

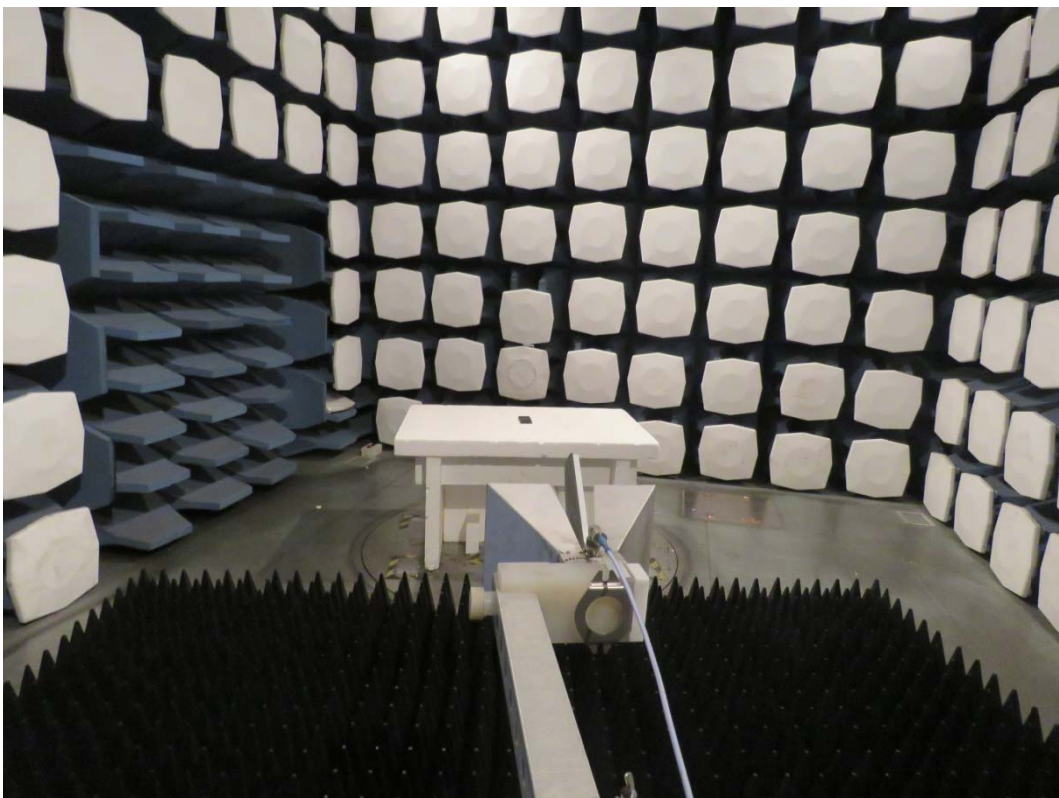

Picture 2: Radiated Spurious Emissions Test setup