



FCC Part 15B TEST REPORT

Report No.: STS2002187E01

Issued for

ZTE Corporation

ZTE Plaza, Keji Road South, Shenzhen, China

Product Name:	Mobile Phone
Brand Name:	ZTE
Model Name:	ZTE Z2316
Series Model:	N/A
FCC ID:	SRQ-ZTEZ2316
Test Standard:	FCC 47 CFR Part 15: Subpart B



Any reproduction of this document must be done in full. No single part of this document may be reproduced without permission from STS, All Test Data Presented in this report is only applicable to presented Test sample.



TEST RESULT CERTIFICATION

Applicant's Name: ZTE Corporation
Address.....: ZTE Plaza, Keji Road South, Shenzhen, China
Manufacture's Name: ZTE Corporation
Address.....: ZTE Plaza, Keji Road South, Shenzhen, China

Product Description:
Product Name: Mobile Phone
Brand Name.....: ZTE
Model Name: ZTE Z2316
Series Model: N/A

Standards.....: FCC 47 CFR Part 15: Subpart B
Test Procedure.....: ANSI C63.4-2014

This device described above has been tested by STS, and the test results show that the equipment under test (EUT) is in compliance with the FCC requirements. And it is applicable only to the tested sample identified in the report.

This report shall not be reproduced except in full, without the written approval of STS, this document may be altered or revised by STS, personal only, and shall be noted in the revision of the document.

Date of Test.....:
Date of Performance of Tests: 27 Feb. 2020~02 Mar. 2020
Date of Issue.....: 03 Mar. 2020
Test Result: Pass

Compiled by : Mickey Deng
(Mickey Deng)

Technical Manager : Chopin Xiao
(Chopin Xiao)

Authorized Signatory : Vita Li
(Vita Li)





Table of Contents

1. SUMMARY OF THE TEST RESULTS	5
1.1 TEST FACTORY	5
1.2 MEASUREMENT UNCERTAINTY	5
2. GENERAL INFORMATION	6
2.1 GENERAL DESCRIPTION OF THE EUT	6
2.2 DESCRIPTION OF THE TEST MODES	8
2.3 BLOCK DIGRAM SHOWING THE CONFIGURATION OF THE SYSTEM TESTED	9
2.4 DESCRIPTION OF THE SUPPORT UNITS	10
2.5 EQUIPMENTS LIST FOR ALL TEST ITEMS	11
3. EMC EMISSION TEST	12
3.1 CONDUCTED EMISSION MEASUREMENT	12
3.2 RADIATED EMISSION MEASUREMENT	16

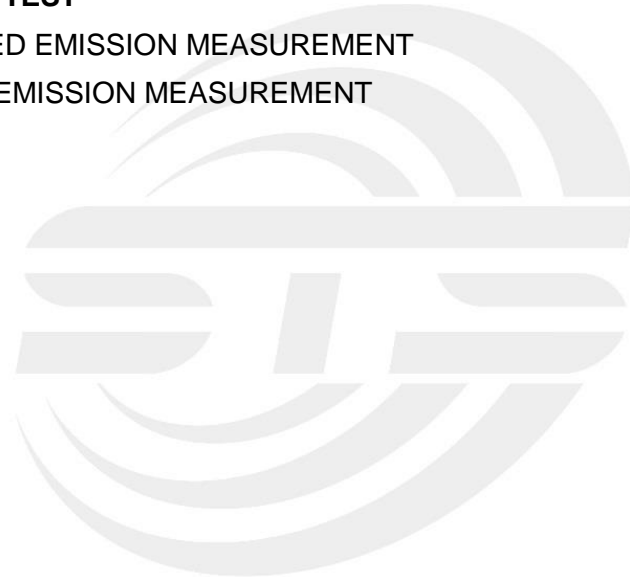



Revision History

Rev.	Issue Date	Report No.	Effect Page	Contents
00	03 Mar. 2020	STS2002187E01	ALL	Initial Issue





1. SUMMARY OF THE TEST RESULTS

Test procedures according to the technical standards:

EMISSION			
Standard	Item	Result	Remarks
FCC 47 CFR Part 15 Subpart B	Conducted Emission	PASS	Meet Class B limit
	Radiated Emission	PASS	Meet Class B limit

NOTE:

(1) "N/A" denotes test is not applicable in this Test Report

1.1 TEST FACTORY

Company Name:	SHENZHEN STS TEST SERVICES CO.,LTD.
Address:	A 1/F, Building B, Zhuoke Science Park, No.190 Chongqing Road, HepingShequ, Fuyong Sub-District, Bao'an District, Shenzhen, Guang Dong, China
Telephone:	+86-755 3688 6288
Fax:	+86-755 3688 6277
Registration No.:	FCC test Firm Registration Number: 625569
	IC test Firm Registration Number: 12108A
	A2LA Certificate No.: 4338.01

1.2 MEASUREMENT UNCERTAINTY

The reported uncertainty of measurement $y \pm U$, where expanded uncertainty U is based on a standard uncertainty multiplied by a coverage factor of $k=2$, providing a level of confidence of approximately 95 %.

No.	Item	Uncertainty
1	Conducted Emission (9KHz-150KHz)	± 3.37 dB
2	Conducted Emission (150KHz-30MHz)	± 3.83 dB
3	All emissions, radiated (<1G) 30MHz-1000MHz	± 5.6 dB
4	All emissions, radiated (>1G) 1GHz-6GHz	± 5.5 dB
5	All emissions, radiated (>1G) 6GHz-18GHz	± 5.8 dB



2. GENERAL INFORMATION

2.1 GENERAL DESCRIPTION OF THE EUT

Product Name	Mobile Phone	
Brand Name	ZTE	
Model Name	ZTE Z2316	
Series Model	N/A	
Product Differences	N/A	
Test Sample Number	2002046-1X	
Frequency Bands	GSM	850:824.2~848.8MHz 1900:1850.2~1909.8MHz
	WCDMA	Band II: 1852.4~1907.6MHz Band V:826.4~846.6MHz Band IV: 1712.4~1752.6MHz
	LTE	Band 2: 1850.7~1909.3MHz Band 4: 1710.7~1754.3MHz Band 5: 824.7~848.3MHz Band 7: 2502.5~2567.5MHz
	WLAN	802 11b/g/n(HT20):2412~2462MHz
	Bluetooth	2402~ 2480MHz
	GPS	1575.42MHz
	FM	87.5~108MHz
	Modulation Mode	GSM
WCDMA		QPSK; HSDPA:QPSK/16QAM; HSUPA:BPSK
LTE		QPSK,16QAM
WLAN		802.11b(DSSS):CCK,DQPSK,DBPSK 802.11g(OFDM):BPSK,QPSK,16-QAM,64-QAM 802.11n(OFDM):BPSK,QPSK,16-QAM,64-QAM
Bluetooth		BT(1Mbps): GFSK BT EDR(2Mbps): $\pi/4$ -DQPSK BT EDR(3Mbps): 8DPSK
BLE		GFSK
GPS		BPSK
FM		FM



Power Source	1. Model: TPA—97050050U01 Input: AC 100-240V,50/60Hz 0.15A Output: DC 5V500mA 2. Model: 50.069EX03 Input: AC 100-240V,50/60Hz 0.2A Output: DC 5V500mA
Battery	Rated Voltage: 3.7V Charge Limit: 4.2V Capacity: 1400mAh
Hardware Version Number	S82M020
Software Version Number	CO-CLARO-S-P920F50V1.0.0B03T

Note: For a more detailed features description, please refer to the manufacturer's specifications or the User's Manual.





2.2 DESCRIPTION OF THE TEST MODES

To investigate the maximum EMI emission characteristics generates from EUT, the test system was pre-scanning tested base on the consideration of following EUT operation mode or test configuration mode which possible have effect on EMI emission level. Each of these EUT operation mode(s) or test configuration mode(s) mentioned above was evaluated respectively.

Pretest Mode	Description
Mode 1	GSM850 Link + Adapter + USB cable + Earphone + BT Link + GPS Rx
Mode 2	PCS1900 Link + Adapter + USB cable + Earphone + BT Link + GPS Rx
Mode 3	WCDMA1900 Link + Adapter + USB cable + Earphone + BT Link + WLAN Link + GPS Rx
Mode 4	WCDMA850 Link + Adapter + USB cable + Earphone + BT Link + WLAN Link + GPS Rx
Mode 5	WCDMA1700 Link + Adapter + USB cable + Earphone + BT Link + WLAN Link + GPS Rx
Mode 6	LTE B2 Link + Adapter + USB cable + Earphone + BT Link + WLAN Link + GPS Rx
Mode 7	LTE B4 Link + Adapter + USB cable + Earphone + BT Link + WLAN Link + GPS Rx
Mode 8	LTE B5 Link + Adapter + USB cable + Earphone + BT Link + WLAN Link + GPS Rx
Mode 9	LTE B7 Link + Adapter + USB cable + Earphone + BT Link + WLAN Link + GPS Rx
Mode 10	PC + USB Transmission + SD Card
Mode 11	Charging + Audio + Video + Earphone
Mode 12	Charging + FM

For Conducted Test	
Final Test Mode	Description
Mode 1	GSM850 Link + Adapter + USB cable + Earphone + BT Link + GPS Rx

For Radiated Test	
Final Test Mode	Description
Mode 1	GSM850 Link + Adapter + USB cable + Earphone + BT Link + GPS Rx

Note:

1. For conducted emission test, test mode 1 was the worst case and only this mode was presented in this report.
2. For radiated emission test, test mode 1 was the worst case and only this mode was presented in this report.
3. We have be tested for all avaiable U.S. voltage and frequencies (For 120V, 50/60Hz) for which the device is capable of operation.

2.3 BLOCK DIGRAM SHOWING THE CONFIGURATION OF THE SYSTEM TESTED

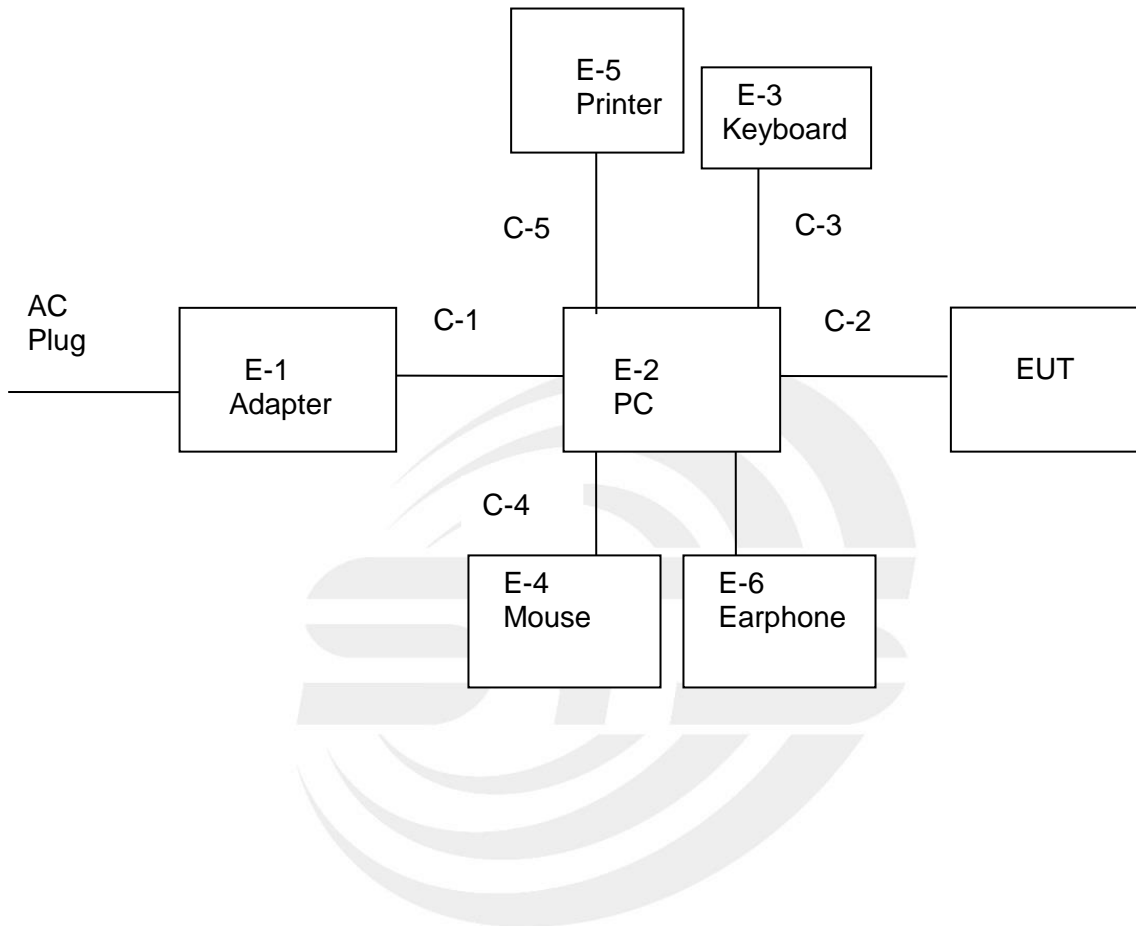

2.4 DESCRIPTION OF THE SUPPORT UNITS

The EUT has been tested as an independent unit together with other necessary accessories or support units. The following support units or accessories were used to form a representative test configuration during the tests.

Accessories equipment

Item	Equipment	Mfr/Brand	Model/Type No.
N/A	N/A	N/A	N/A

Auxiliary equipment

Item	Equipment	Mfr/Brand	Model/Type No.
E-1	Adapter	HP	HSTNN-CA15
E-2	PC	HP	500-320cx
E-3	Keyboard	Acer	SK-9624
E-4	Mouse	HP	MODGUO
E-5	Printer	LENOVO	LJ2400L
E-6	Earphone	N/A	N/A

Cable

Item	Type	Shielded Type	Ferrite Core	Length
C-1	N/A	Shielded	NO	150cm
C-2	USB Cable (FTP)	Shielded	NO	90cm
C-3	USB Cable (FTP)	Shielded	NO	180cm
C-4	USB Cable (FTP)	Shielded	NO	180cm
C-5	USB Cable (FTP)	Shielded	NO	120cm

Note:

- (1) The support equipment was authorized by Declaration of Confirmation.
- (2) For detachable type I/O cable should be specified the length in cm in 『Length』 column.
- (3) “YES” is means “shielded” “with core”; “NO” is means “unshielded” “without core”.
- (4) PC is the FCC DOC is approved.
- (5) Both models of power supply TPA—97050050U01 and model 50.069EX03 have evaluation tests, but the worst mode data put in the report is mode TPA—97050050U01.



2.5 EQUIPMENTS LIST FOR ALL TEST ITEMS

The EUT has been tested as an independent unit together with other necessary accessories or support units. The following support units or accessories were used to form a representative test configuration during the tests.

Radiation Test equipment

Kind of Equipment	Manufacturer	Type No.	Serial No.	Last Calibration	Calibrated Until
EMI Test Receiver	R&S	ESCI	101427	2019.10.09	2020.10.08
Bi-log Antenna	TESEQ	CBL6111D	34678	2017.11.02	2020.11.01
Horn Antenna	SCHWARZB ECK	BBHA 9120D	9120D-1343	2018.10.19	2021.10.18
Pre-amplifier(1G-26.5G)	Agilent	8449B	3008A02383	2019.10.11	2020.10.10
Pre-amplifier(0.1M-3 GHz)	EM	EM330	060665	2019.10.09	2020.10.08
Spectrum Analyzer	Agilent	N9020A	MY49100060	2019.10.09	2020.10.08
RE Cable (9K-1G)	N/A	R01	N/A	2019.10.12	2020.10.11
RE Cable (1G-26G)	N/A	R02	N/A	2019.10.12	2020.10.11
Temperature & Humidity	Mieo	HH660	N/A	2019.10.12	2020.10.11
Horn Antenna(18-40GHz)	A-INFO	LB-180400-KF	J211020657	2018.03.11	2021.03.10
Testing Software	EZ-EMC(Ver.STSLAB-03A1 RE)				

Conduction Test equipment

Kind of Equipment	Manufacturer	Type No.	Serial No.	Last Calibration	Calibrated Until
EMI Test Receiver	R&S	ESCI	101427	2019.10.09	2020.10.08
LISN	R&S	ENV216	101242	2019.10.09	2020.10.08
LISN	ETS	3810/2NM	00023625	2019.10.09	2020.10.08
Absorbing Clamp	R&S	MDS-21	100668	2019.10.09	2020.10.08
CE Cable	N/A	C01	N/A	2019.10.12	2020.10.11
Temperature & Humidity	Mieo	HH660	N/A	2019.10.12	2020.10.11
Testing Software	EZ-EMC(Ver.STSLAB-03A1 CE)				



3. EMC EMISSION TEST

3.1 CONDUCTED EMISSION MEASUREMENT

3.1.1 POWER LINE CONDUCTED EMISSION Limits

FREQUENCY (MHz)	Conducted Emission Limits (dBuV)			
	Class A		Class B	
	Quasi-peak	Average	Quasi-peak	Average
0.15 -0.5	79.00	66.00	66 - 56 *	56 - 46 *
0.50 -5.0	73.00	60.00	56.00	46.00
5.0 -30.0	73.00	60.00	60.00	50.00

Note:

- (1) The tighter limit applies at the band edges.
- (2) The limit of " * " marked band means the limitation decreases linearly with the logarithm of the frequency in the range.

The following table is the setting of the receiver

Receiver Parameters	Setting
Attenuation	10 dB
Start Frequency	0.15 MHz
Stop Frequency	30 MHz
IF Bandwidth	9 kHz

3.1.2 TEST PROCEDURE

- a. The EUT was placed 0.4 meters from the conducting wall of the shielded room with EUT being connected to the power mains through a line impedance stabilization network (LISN). Other support units were connected to the power mains through another LISN. The two LISNs provide 50 Ohm/ 50uH of coupling impedance for the measuring instrument.
- b. Interconnecting cables that hang closer than 40 cm to the ground plane shall be folded back and forth in the center forming a bundle 30 to 40 cm long.
- c. I/O cables that are not connected to a peripheral shall be bundled in the center. The end of the cable may be terminated, if required, using the correct terminating impedance. The overall length shall not exceed 1 m.
- d. For the actual test configuration, please refer to the related Item –EUT Test Photos.

3.1.3 DEVIATION FROM TEST STANDARD

No deviation

3.1.4 TEST SETUP

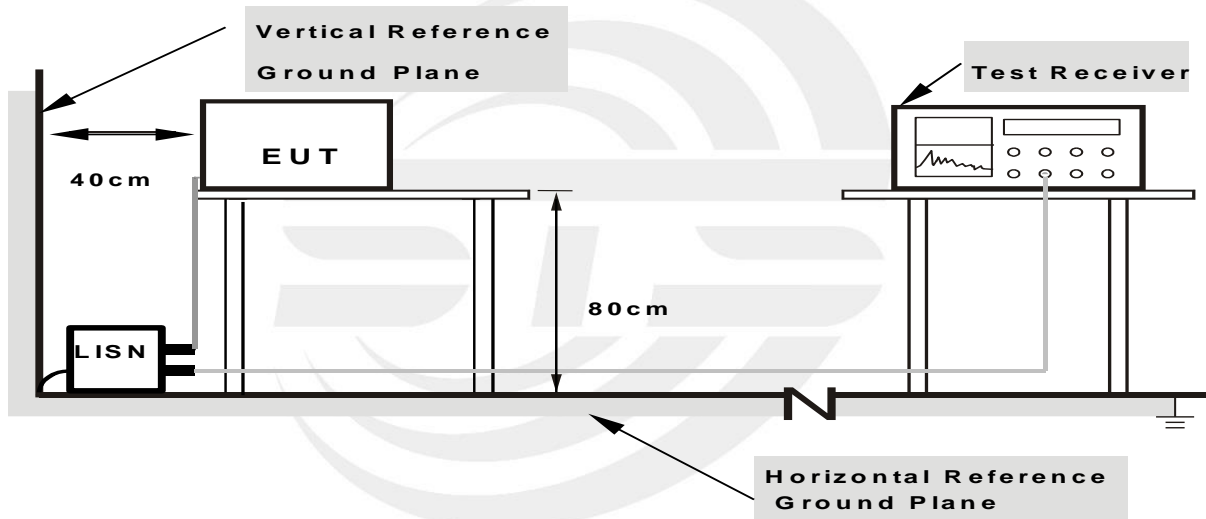

- Note: 1.Support units were connected to second LISN.**
2.Both of LISNs (AMN) are 80 cm from EUT and at least 80 from other units and other metal planes

3.1.5 EUT OPERATING CONDITIONS

The EUT was configured for testing in a typical fashion (as a customer would normally use it). The EUT has been programmed to continuously transmit during test. This operating condition was tested and used to collect the included data.



3.1.6 TEST RESULTS

Temperature:	22.9°C	Relative Humidity:	47%
Phase:	L	Test Mode:	Mode 1
Test Voltage:	AC 120V/60Hz	Test Date:	2020.02.28

No.	Frequency (MHz)	Reading (dBuV)	Correct Factor (dB)	Result (dBuV)	Limit (dBuV)	Margin (dB)	Detector
1	0.1660	38.90	19.79	58.69	65.16	-6.47	QP
2	0.1660	19.65	19.79	39.44	55.16	-15.72	AVG
3	0.4300	33.39	20.03	53.42	57.25	-3.83	QP
4	0.4300	20.91	20.03	40.94	47.25	-6.31	AVG
5	0.5860	27.97	19.95	47.92	56.00	-8.08	QP
6	0.5860	13.22	19.95	33.17	46.00	-12.83	AVG
7	1.2500	26.72	19.80	46.52	56.00	-9.48	QP
8	1.2500	12.21	19.80	32.01	46.00	-13.99	AVG
9	3.8900	25.06	19.83	44.89	56.00	-11.11	QP
10	3.8900	8.54	19.83	28.37	46.00	-17.63	AVG
11	14.0900	14.41	20.23	34.64	60.00	-25.36	QP
12	14.0900	0.72	20.23	20.95	50.00	-29.05	AVG

Remark:

1. All readings are Quasi-Peak and Average values
2. Margin = Result (Result = Reading + Factor) - Limit
3. Factor = Insertion loss + Cable loss

80.0 dBuV

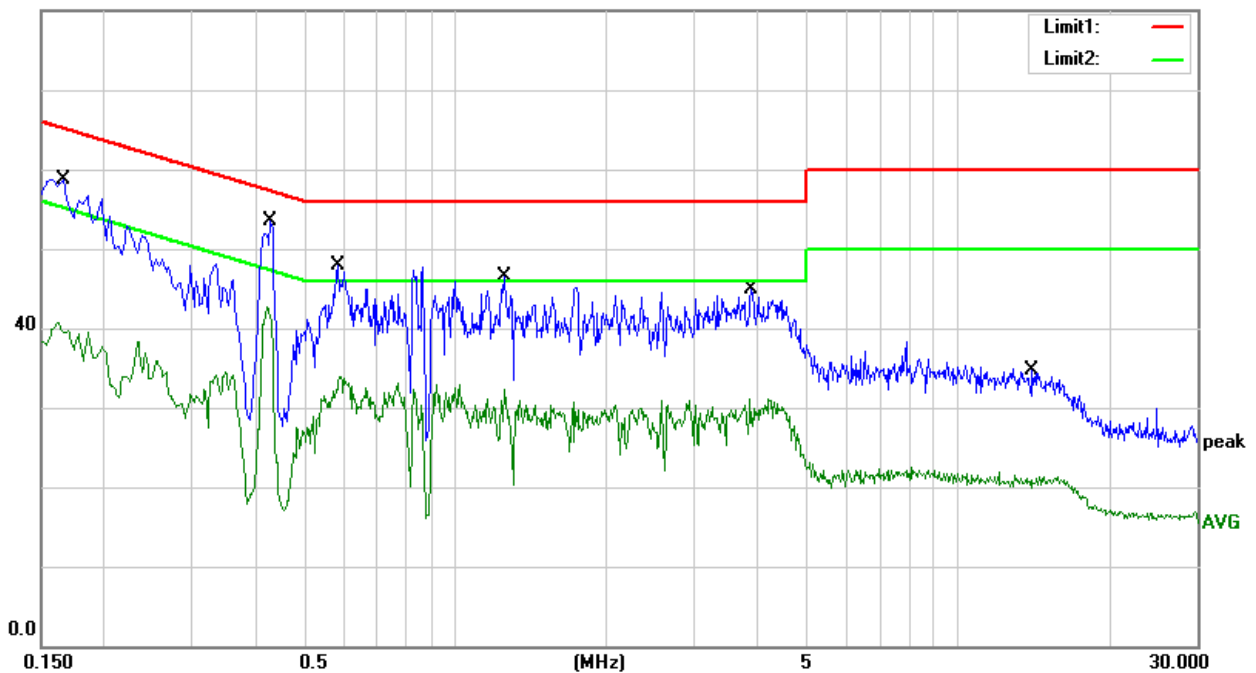



Temperature:	22.9°C	Relative Humidity:	47%
Phase:	N	Test Mode:	Mode 1
Test Voltage:	AC 120V/60Hz	Test Date:	2020.02.28

No.	Frequency (MHz)	Reading (dBuV)	Correct Factor (dB)	Result (dBuV)	Limit (dBuV)	Margin (dB)	Detector
1	0.1620	38.52	19.78	58.30	65.36	-7.06	QP
2	0.1620	17.80	19.78	37.58	55.36	-17.78	AVG
3	0.4260	31.64	20.04	51.68	57.33	-5.65	QP
4	0.4260	20.01	20.04	40.05	47.33	-7.28	AVG
5	0.7740	26.32	19.84	46.16	56.00	-9.84	QP
6	0.7740	10.90	19.84	30.74	46.00	-15.26	AVG
7	1.7100	26.07	19.85	45.92	56.00	-10.08	QP
8	1.7100	7.05	19.85	26.90	46.00	-19.10	AVG
9	3.8420	24.89	19.94	44.83	56.00	-11.17	QP
10	3.8620	4.48	19.94	24.42	46.00	-21.58	AVG
11	14.9580	10.76	20.07	30.83	60.00	-29.17	QP
12	14.9580	-1.82	20.07	18.25	50.00	-31.75	AVG

Remark:

1. All readings are Quasi-Peak and Average values
2. Margin = Result (Result = Reading + Factor) – Limit
3. Factor = Insertion loss + Cable loss

80.0 dBuV

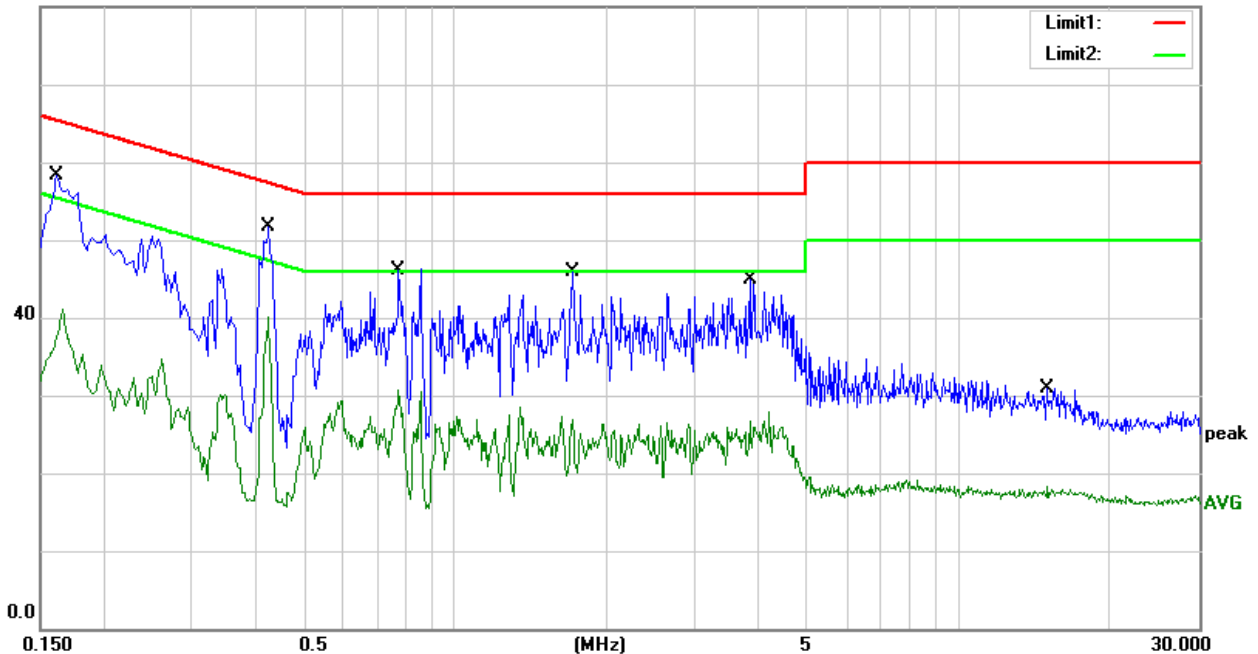

Note:

1. The test voltage is 100-240V, both of which have assessment tests, and the worst test data is in the report.
2. Both models of power supply TPA—97050050U01 and model 50.069EX03 have evaluation tests, but the worst mode data put in the report is mode TPA—97050050U01.

3.2 RADIATED EMISSION MEASUREMENT

3.2.1 Radiated Emission Limits

Class A: ITE that meets the conditions for Class A operation defined in Section 2.2 shall comply with the Class A radiated limits set out in Table 4 determined at a distance of 3 metres.

Class A Radiated Limits Below 1 GHz:

Frequencies (MHz)	Class A (dB μ V/m)
	Quasi-peak
30~88	49.5
88~216	53.9
216~960	56.9
960~1000	60

Class B: ITE that does not meet the conditions for Class A operation shall comply with the Class B radiated limits set out in Table 5 determined at a distance of 3 metres.

Class B Radiated Limits Below 1 GHz:

Frequencies (MHz)	Class B (dB μ V/m)
	Quasi-peak
30~88	40
88~216	43.5
216~960	46
960~1000	54

In case the emission 109(a) limit in the table below has to be followed.

Frequencies (MHz)	Field Strength (micorvolts/meter)	Measurement Distance (meters)
30~88	100	3
88~216	150	3
216~960	200	3
Above 960	500	3



LIMITS OF RADIATED EMISSION MEASUREMENT

FREQUENCY (MHz)	Class A (dBuV/m) (at 3M)		Class B (dBuV/m) (at 3M)	
	PEAK	AVERAGE	PEAK	AVERAGE
Above 1000	80	60	74	54

Note:

- (1) The limit for radiated test was performed in the following: FCC PART 15B.
- (2) The tighter limit applies at the band edges.
- (3) Emission level (dBuV/m) = 20log Emission level (uV/m).

FREQUENCY RANGE OF THE RADIATED MEASUREMENT (For unintentional radiators)

Highest frequency generated or Upper frequency of measurement used in the device or on which the device operates or tunes (MHz)	Range (MHz)
Below 1.705	30
1.705 – 108	1000
108 – 500	2000
500 – 1000	5000
Above 1000	5th harmonic of the highest frequency or 40 GHz, whichever is lower



Spectrum Parameter	Setting
Attenuation	Auto
Detector	Peak
Start Frequency	1000 MHz(Peak/AV)
Stop Frequency	5th harmonic (Peak/AV)
RB / VB (emission in restricted band)	30MHz to 1000MHz: 100 KHz / 300 KHz Above 1000MHz: 1 MHz / 3 MHz

Receiver Parameter	Setting
Attenuation	Auto
Start ~ Stop Frequency	30MHz to 1000MHz: 100 KHz / 300 KHz Above 1000MHz: 1 MHz / 3 MHz

3.2.2 TEST PROCEDURE

- The EUT was placed on the top of a rotating table 0.8 meters above the ground at a 3 meter semi-anechoic chamber room. The table was rotated 360 degrees to determine the position of the highest radiation.
- EUT as the center to the edge of the auxiliary device, the distance from the maximum edge to the center of the antenna is 3 meters.
- The height of antenna is varied from 1 meter to 4 meters above the ground to determine the maximum value of the field strength. Both horizontal and vertical polarizations of the antenna are set to make the measurement.
- For each suspected emission, the EUT was arranged to its worst case and then the antenna was tuned to heights from 1 meter to 4 meters and the rotatable table was turned from 0 degrees to 360 degrees to find the maximum reading.
- The test-receiver system was set to quasi-peak detect function and specified bandwidth with maximum hold mode when the test frequency is below 1GHz.
- For the actual test configuration, please refer to the related Item –EUT Test Photos.

Note: Both horizontal and vertical antenna polarities were tested and performed pretest to three orthogonal axis. The worst case emissions were reported

3.2.3 DEVIATION FROM TEST STANDARD

No deviation

3.2.4 TEST SETUP

(A) Radiated Emission Test-Up Frequency 30MHz~1GHz

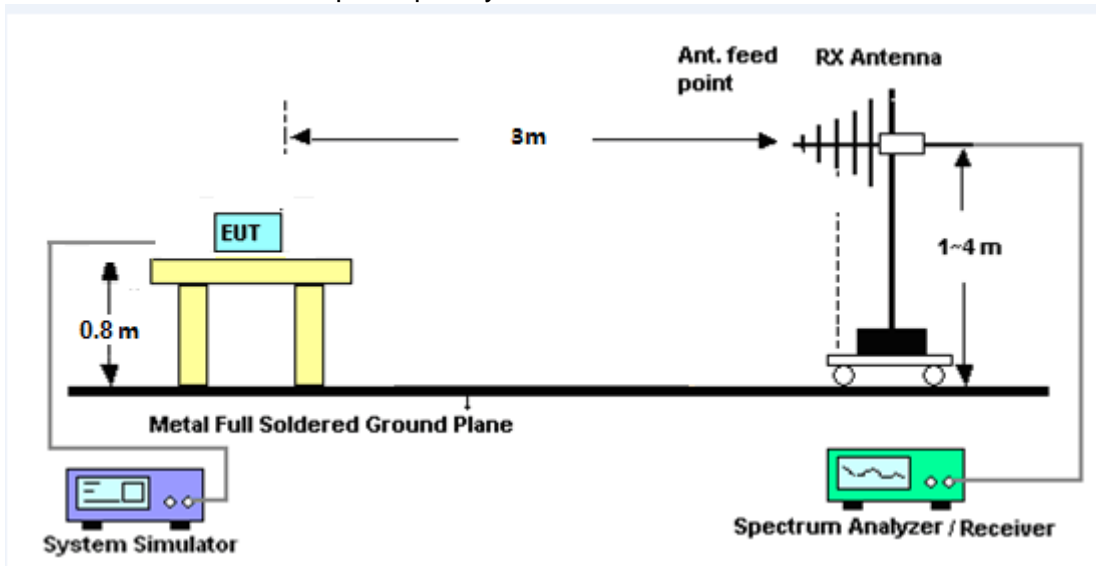

(B) Radiated Emission Test-Up Frequency Above 1GHz

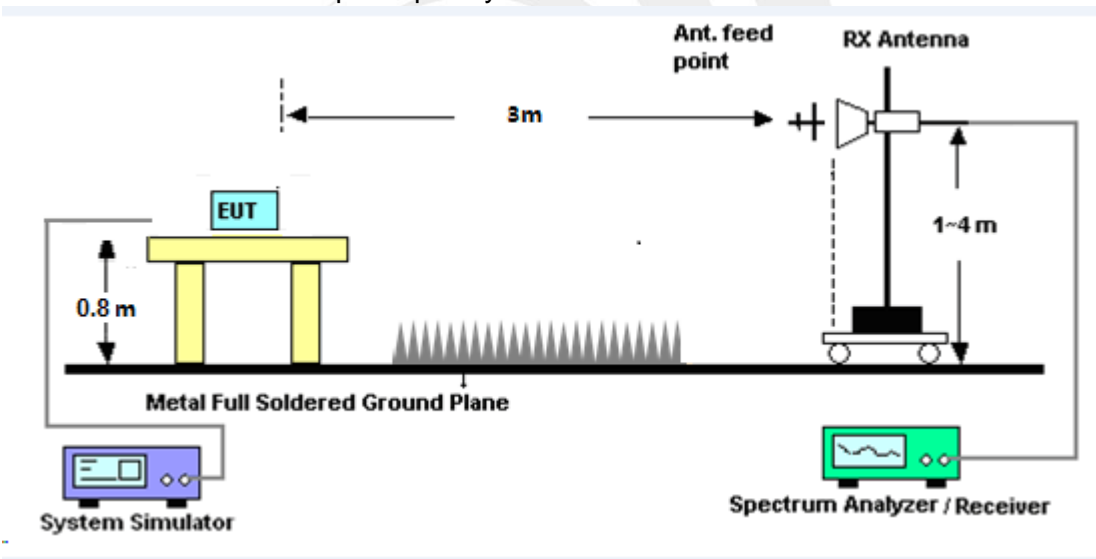

3.2.5 EUT OPERATING CONDITIONS

The EUT tested system was configured as the statements of 2.4 Unless otherwise a special operating condition is specified in the following during the testing.



3.2.6 TEST RESULTS

30MHz -1000MHz

Temperature:	21.6°C	Relative Humidity:	45%
Phase:	Horizontal	Test Mode:	Mode 1
Test Voltage:	AC 120V/60Hz	Test Date:	2020.02.27

No.	Frequency (MHz)	Reading (dBuV)	Correct Factor (dB)	Results (dBuV/m)	Limit (dBuV/m)	Margin (dB)	Detector
1	100.2286	36.89	-19.95	16.94	43.50	-26.56	QP
2	186.4408	39.11	-21.30	17.81	43.50	-25.69	QP
3	240.8304	43.09	-19.10	23.99	46.00	-22.01	QP
4	480.5276	38.87	-11.00	27.87	46.00	-18.13	QP
5	528.2458	45.88	-10.25	35.63	46.00	-10.37	QP
6	576.6443	38.60	-8.76	29.84	46.00	-16.16	QP

Remark:

1. All readings are Quasi-Peak
2. Margin = Result (Result =Reading + Factor)–Limit
3. Factor= Cable Loss +Antenna Factor-Amplifier Gain

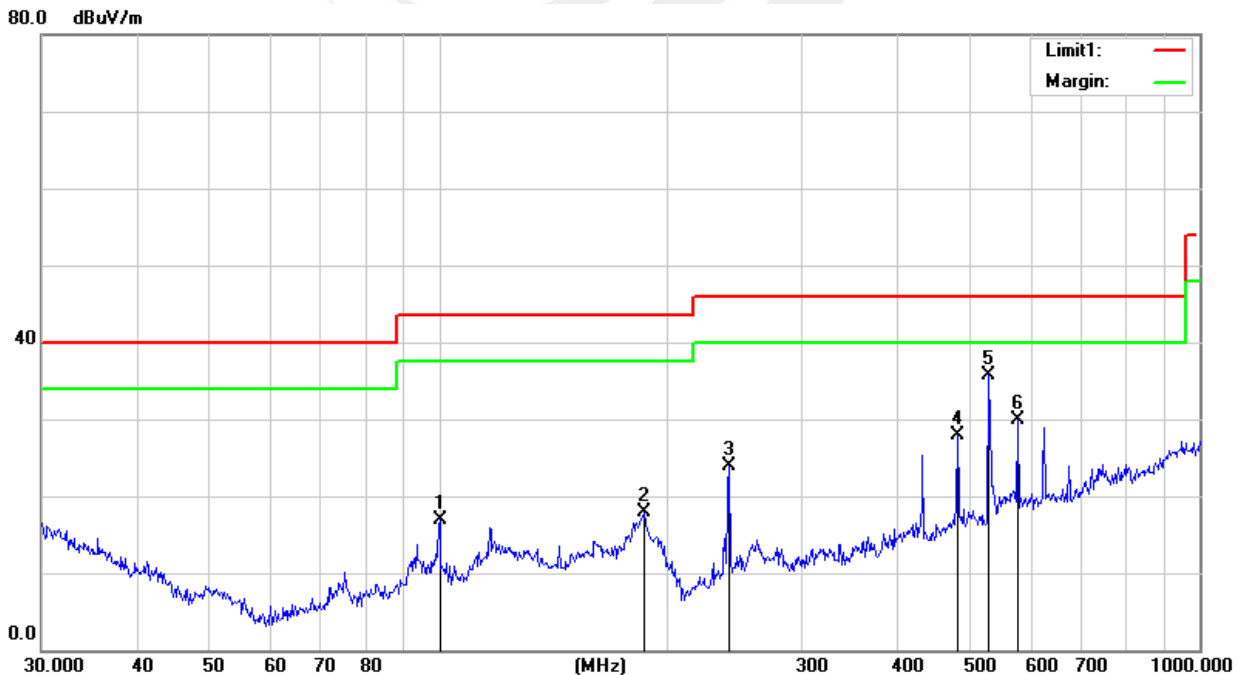



Temperature:	21.6°C	Relative Humidity:	45%
Phase:	Vertical	Test Mode:	Mode 1
Test Voltage:	AC 120V/60Hz	Test Date:	2020.02.27

No.	Frequency (MHz)	Reading (dBuV)	Correct Factor (dB)	Results (dBuV/m)	Limit (dBuV/m)	Margin (dB)	Detector
1	100.2286	38.97	-19.95	19.02	43.50	-24.48	QP
2	116.5400	34.61	-18.71	15.90	43.50	-27.60	QP
3	240.8303	35.59	-19.10	16.49	46.00	-29.51	QP
4	480.5276	33.10	-11.00	22.10	46.00	-23.90	QP
5	528.2458	43.58	-10.25	33.33	46.00	-12.67	QP
6	625.0780	39.52	-8.60	30.92	46.00	-15.08	QP

Remark:

1. All readings are Quasi-Peak
2. Margin = Result (Result = Reading + Factor) – Limit
3. Factor = Cable Loss + Antenna Factor - Amplifier Gain

80.0 dBuV/m

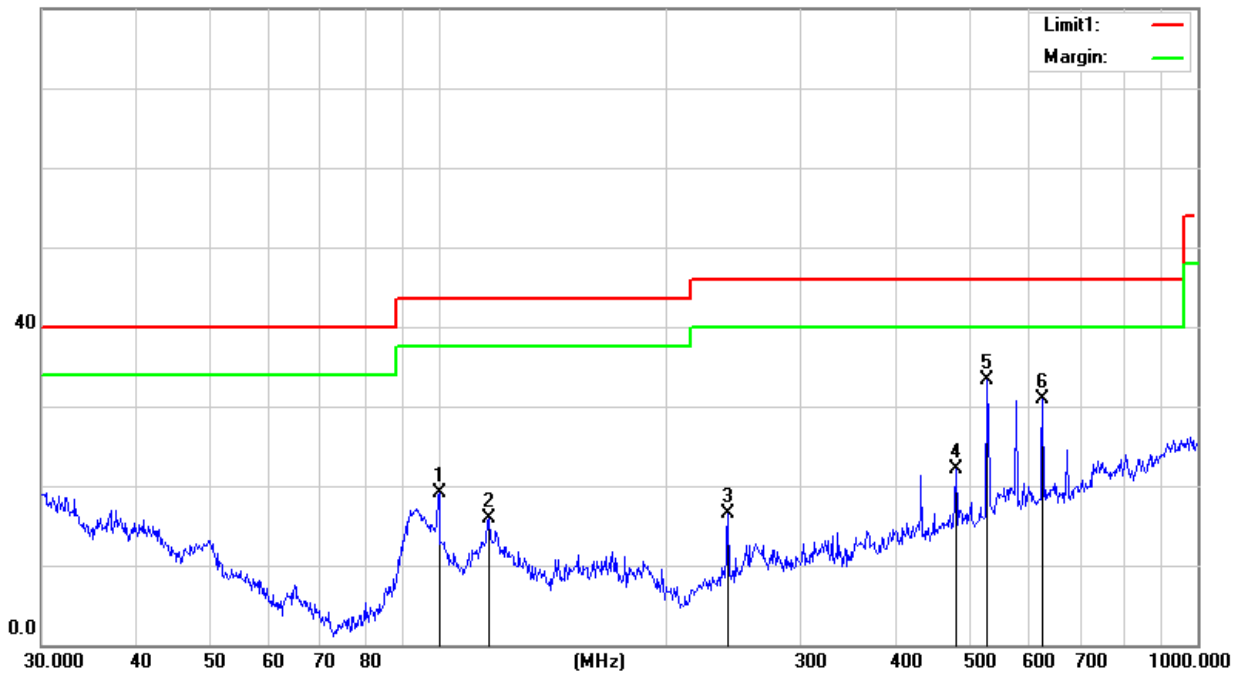

Note: Both models of power supply TPA-97050050U01 and model 50.069EX03 have evaluation tests, but the worst mode data put in the report is mode TPA-97050050U01.



(1 GHz to 18GHz.)

Temperature:	21.6°C	Relative Humidity:	45%
Phase:	Horizontal	Test Mode:	Mode 1
Test Voltage:	AC 120V/60Hz	Test Date:	2020.02.27

No.	Frequency (MHz)	Reading (dBuV)	Correct Factor (dB)	Result (dBuV)	Limit (dBuV)	Margin (dB)	Remark
1	9245.000	31.24	13.97	45.21	74.00	-28.79	Peak
2	9245.000	21.50	13.97	35.47	54.00	-18.53	AVG
3	10775.000	33.33	14.03	47.36	74.00	-26.64	Peak
4	10775.000	22.26	14.03	36.29	54.00	-17.71	AVG
5	12900.000	32.90	15.37	48.27	74.00	-25.73	Peak
6	12900.000	22.88	15.37	38.25	54.00	-15.75	AVG
7	15254.500	34.65	17.62	52.27	74.00	-21.73	Peak
8	15254.500	24.44	17.62	42.06	54.00	-11.94	AVG
9	16648.500	35.13	17.92	53.05	74.00	-20.95	Peak
10	16648.500	25.09	17.92	43.01	54.00	-10.99	AVG
11	17490.000	32.18	21.41	53.59	74.00	-20.41	Peak
12	17490.000	22.39	21.41	43.80	54.00	-10.20	AVG

Remark:

1. All readings are Peak and Average values
2. Margin = Result (Result =Reading + Factor)–Limit
3. Factor= Cable Loss +Antenna Factor-Amplifier Gain

80.0 dBuV/m

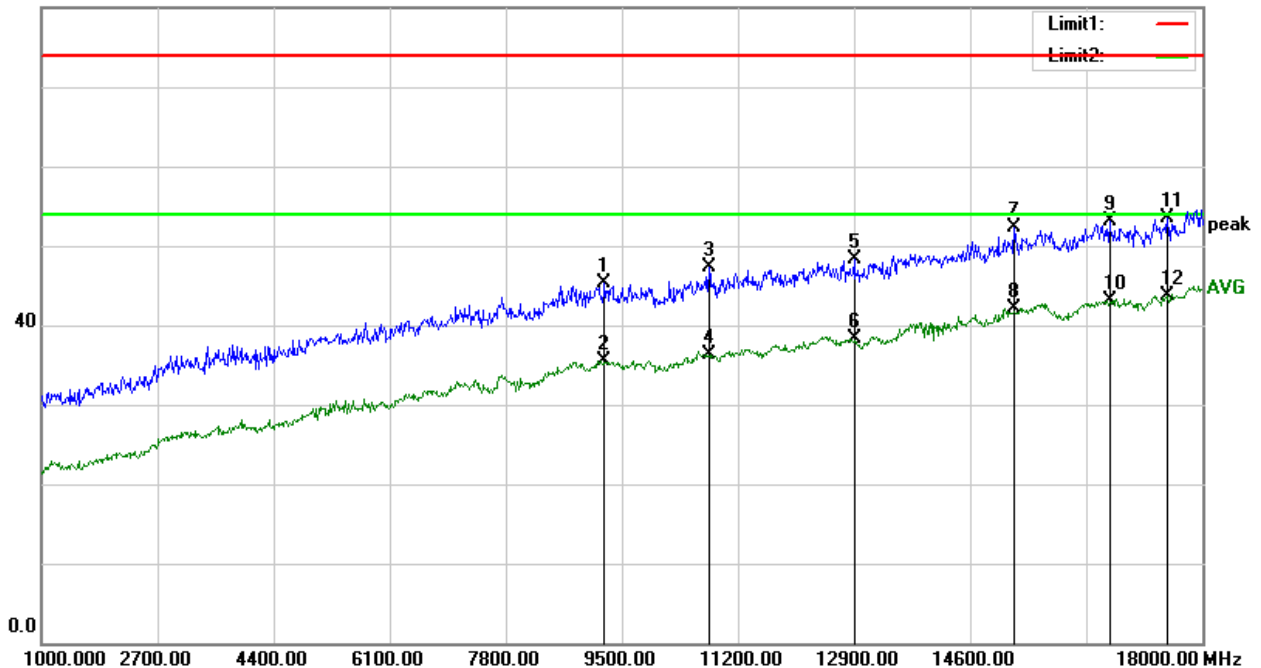



Temperature:	21.6°C	Relative Humidity:	45%
Phase:	Vertical	Test Mode:	Mode 1
Test Voltage:	AC 120V/60Hz	Test Date:	2020.02.27

No.	Frequency (MHz)	Reading (dBuV)	Correct Factor (dB)	Result (dBuV)	Limit (dBuV)	Margin (dB)	Remark
1	5411.500	32.35	7.23	39.58	74.00	-34.42	Peak
2	5411.500	22.96	7.23	30.19	54.00	-23.81	AVG
3	7783.000	32.64	11.11	43.75	74.00	-30.25	Peak
4	7783.000	23.33	11.11	34.44	54.00	-19.56	AVG
5	8964.500	31.68	13.38	45.06	74.00	-28.94	Peak
6	8964.500	21.71	13.38	35.09	54.00	-18.91	AVG
7	12203.000	32.37	15.08	47.45	74.00	-26.55	Peak
8	12203.000	23.65	15.08	38.73	54.00	-15.27	AVG
9	14778.500	34.11	17.99	52.10	74.00	-21.90	Peak
10	14778.500	24.48	17.99	42.47	54.00	-11.53	AVG
11	17813.000	31.58	24.39	55.97	74.00	-18.03	Peak
12	17813.000	23.00	24.39	47.39	54.00	-6.61	AVG

Remark:

1. All readings are Peak and Average values
2. Margin = Result (Result = Reading + Factor) – Limit
3. Factor = Cable Loss + Antenna Factor - Amplifier Gain

80.0 dBuV/m

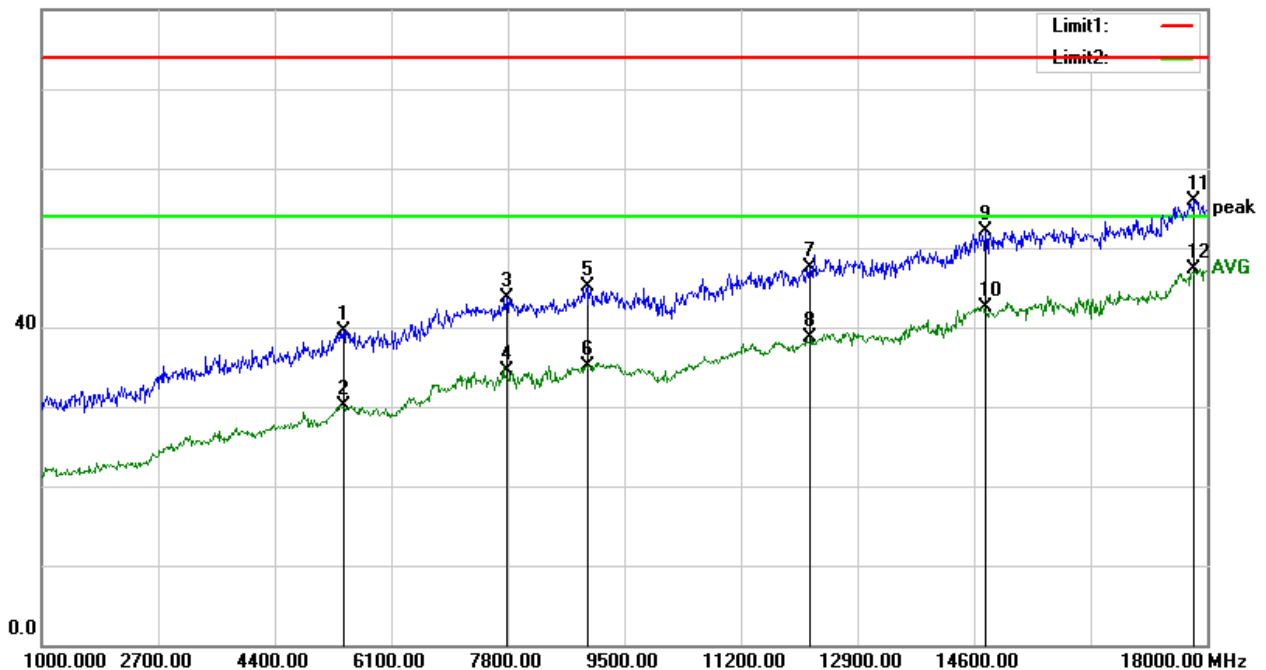



(18 GHz to 25GHz.)

Temperature:	21.6°C	Relative Humidity:	45%
Phase:	Horizontal	Test Mode:	Mode 1
Test Voltage:	AC 120V/60Hz	Test Date:	2020.02.27

No.	Frequency (MHz)	Reading (dBuV)	Correct Factor (dB)	Result (dBuV)	Limit (dBuV)	Margin (dB)	Remark
1	18728.000	25.77	24.69	50.46	74.00	-23.54	Peak
2	18728.000	14.95	24.69	39.64	54.00	-14.36	AVG
3	21045.000	27.04	24.89	51.93	74.00	-22.07	Peak
4	21045.000	17.68	24.89	42.57	54.00	-11.43	AVG
5	21619.000	28.14	24.69	52.83	74.00	-21.17	Peak
6	21619.000	18.55	24.69	43.24	54.00	-10.76	AVG
7	22886.000	29.23	24.52	53.75	74.00	-20.25	Peak
8	22886.000	19.34	24.52	43.86	54.00	-10.14	AVG
9	23705.000	31.53	24.77	56.30	74.00	-17.70	Peak
10	23705.000	22.11	24.77	46.88	54.00	-7.12	AVG
11	24860.000	32.75	24.96	57.71	74.00	-16.29	Peak
12	24860.000	23.11	24.96	48.07	54.00	-5.93	AVG

Remark:

1. All readings are Peak and Average values
2. Margin = Result (Result =Reading + Factor)–Limit
3. Factor= Cable Loss +Antenna Factor-Amplifier Gain

80.0 dBuV/m

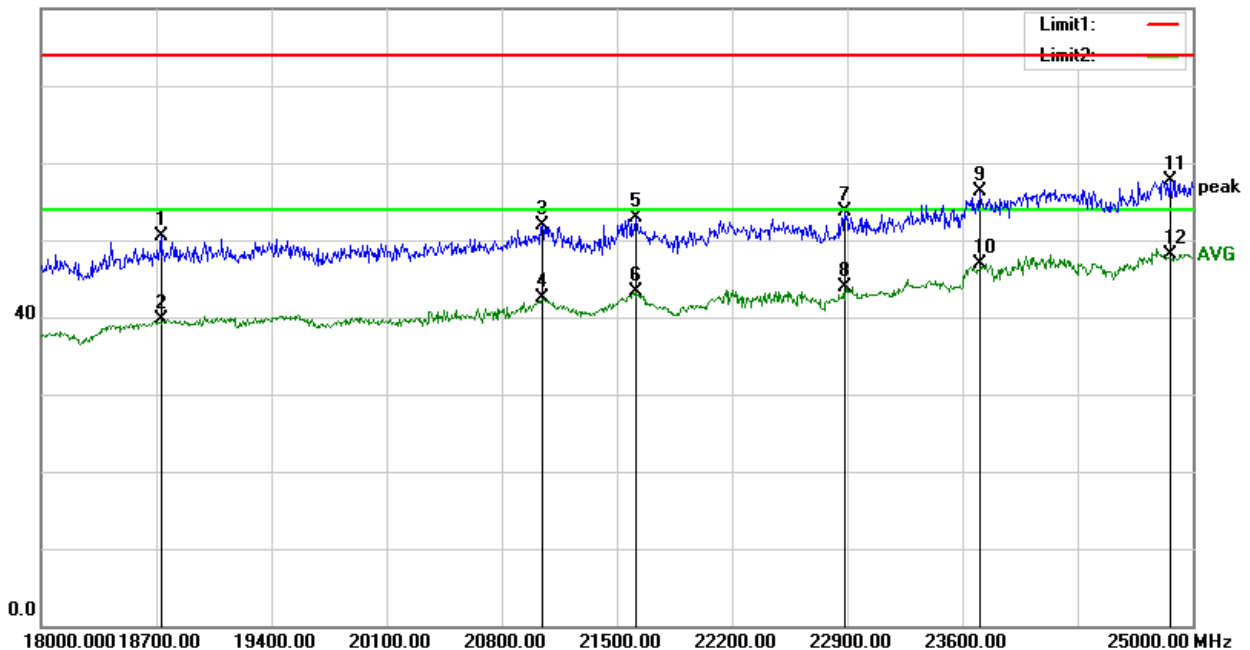



Temperature:	21.6°C	Relative Humidity:	45%
Phase:	Vertical	Test Mode:	Mode 1
Test Voltage:	AC 120V/60Hz	Test Date:	2020.02.27

No.	Frequency (MHz)	Reading (dBuV)	Correct Factor (dB)	Result (dBuV)	Limit (dBuV)	Margin (dB)	Remark
1	20625.000	25.83	24.94	50.77	74.00	-23.23	Peak
2	20625.000	16.02	24.94	40.96	54.00	-13.04	AVG
3	21052.000	27.13	24.89	52.02	74.00	-21.98	Peak
4	21052.000	17.86	24.89	42.75	54.00	-11.25	AVG
5	21598.000	28.49	24.71	53.20	74.00	-20.80	Peak
6	21598.000	18.59	24.71	43.30	54.00	-10.70	AVG
7	23320.000	29.59	24.67	54.26	74.00	-19.74	Peak
8	23320.000	20.56	24.67	45.23	54.00	-8.77	AVG
9	23754.000	31.51	24.79	56.30	74.00	-17.70	Peak
10	23754.000	22.43	24.79	47.22	54.00	-6.78	AVG
11	24706.000	32.77	24.96	57.73	74.00	-16.27	Peak
12	24706.000	23.17	24.96	48.13	54.00	-5.87	AVG

Remark:

1. All readings are Peak and Average values
2. Margin = Result (Result = Reading + Factor) – Limit
3. Factor = Cable Loss + Antenna Factor – Amplifier Gain

80.0 dBuV/m

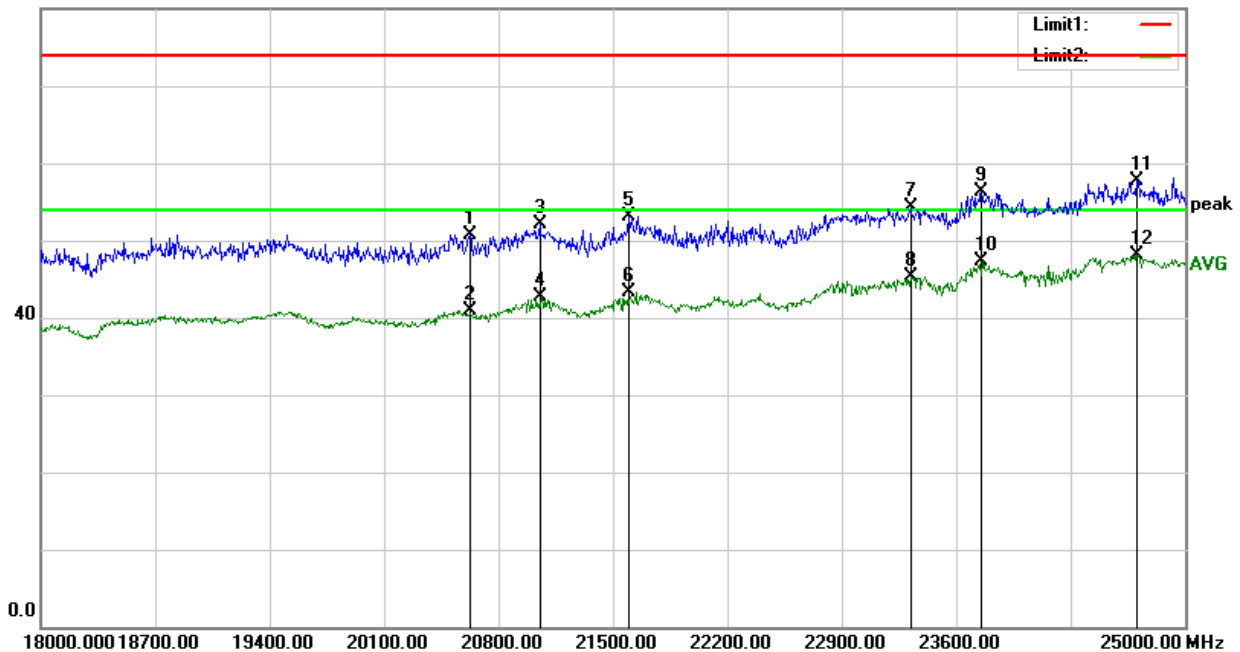

Notes:

1. Measuring frequencies from 1 GHz to 25GHz.
2. Radiated emissions measured in frequency above 1000MHz were made with an instrument using Peak detector mode of the emission shown in Actual FS column.

END OF THE REPORT