



# FCC RF Test Report

APPLICANT : ZTE CORPORATION  
EQUIPMENT : CDMA 1X & EVDO Dual-Mode Digital Mobile Phone  
BRAND NAME : ZTE  
MODEL NAME : ZTE N817  
FCC ID : SRQ-ZTEN817  
STANDARD : FCC 47 CFR Part 2, 22(H), 24(E)  
CLASSIFICATION : PCS Licensed Transmitter Held to Ear (PCE)

The product was received on May 28, 2015 and testing was completed on Jul. 10, 2015. We, SPORTON INTERNATIONAL (SHENZHEN) INC., would like to declare that the tested sample has been evaluated in accordance with the test procedures given in ANSI / TIA / EIA-603-C-2004 and has been in compliance with the applicable technical standards.

The test results in this report apply exclusively to the tested model / sample. Without written approval of SPORTON INTERNATIONAL (SHENZHEN) INC., the test report shall not be reproduced except in full.

Reviewed by: Joseph Lin / Supervisor

Approved by: Jones Tsai / Manager



**SPORTON INTERNATIONAL (SHENZHEN) INC.**

1F & 2F, Building A, Morning Business Center, No. 4003 ShiGu Rd., Xili Town,  
Nanshan District, Shenzhen, Guangdong, P. R. China



# TABLE OF CONTENTS

**REVISION HISTORY..... 3**

**SUMMARY OF TEST RESULT ..... 4**

**1 GENERAL DESCRIPTION ..... 5**

    1.1 Applicant..... 5

    1.2 Manufacturer ..... 5

    1.3 Product Feature of Equipment Under Test ..... 5

    1.4 Product Specification subjective to this standard..... 5

    1.5 Modification of EUT ..... 6

    1.6 Maximum ERP/EIRP Power, Frequency Tolerance, and Emission Designator ..... 6

    1.7 Testing Location ..... 7

    1.8 Applicable Standards ..... 7

**2 TEST CONFIGURATION OF EQUIPMENT UNDER TEST ..... 8**

    2.1 Test Mode..... 8

    2.2 Connection Diagram of Test System ..... 9

    2.3 Support Unit used in test configuration ..... 9

    2.4 Measurement Results Explanation Example ..... 10

**3 TEST RESULT ..... 11**

    3.1 Conducted Output Power Measurement..... 11

    3.2 Peak-to-Average Ratio ..... 13

    3.3 Effective Radiated Power and Effective Isotropic Radiated Power Measurement ..... 19

    3.4 99% Occupied Bandwidth and 26dB Bandwidth Measurement..... 22

    3.5 Band Edge Measurement..... 30

    3.6 Conducted Spurious Emission Measurement..... 35

    3.7 Field Strength of Spurious Radiation Measurement ..... 38

    3.8 Frequency Stability Measurement..... 42

**4 LIST OF MEASURING EQUIPMENT ..... 46**

**5 UNCERTAINTY OF EVALUATION ..... 47**

**APPENDIX A. SETUP PHOTOGRAPHS**



### REVISION HISTORY

REPORT NO.	VERSION	DESCRIPTION	ISSUED DATE
FG552801	Rev. 01	Initial issue of report	Aug. 07, 2015



### SUMMARY OF TEST RESULT

Report Section	FCC Rule	Description	Limit	Result	Remark
3.1	§2.1046	Conducted Output Power	N/A	PASS	-
3.2	§24.232(d)	Peak-to-Average Ratio	<13 dB	PASS	-
3.3	§22.913(a)(2)	Effective Radiated Power	< 7 Watts	PASS	-
3.3	§24.232(c)	Equivalent Isotropic Radiated Power	< 2 Watts	PASS	-
3.4	§2.1049	Occupied Bandwidth	N/A	PASS	-
3.5	§2.1051 §22.917(a) §24.238(a)	Band Edge Measurement	< 43+10log <sub>10</sub> (P[Watts])	PASS	-
3.6	§2.1051 §22.917(a) §24.238(a)	Conducted Spurious Emission	< 43+10log <sub>10</sub> (P[Watts])	PASS	-
3.7	§2.1053 §22.917(a) §24.238(a)	Field Strength of Spurious Radiation	< 43+10log <sub>10</sub> (P[Watts])	PASS	Under limit 22.83 dB at 3760.000 MHz
3.8	§2.1055 §22.355 §2.1055 §24.235	Frequency Stability for Temperature & Voltage	< 2.5 ppm for Part 22 Within Authorized Band	PASS	-



# 1 General Description

## 1.1 Applicant

**ZTE CORPORATION**

ZTE Plaza, Keji Road South, Hi-Tech, Industrial Park, Nanshan District, Shenzhen, Guangdong, 518057, P.R.China

## 1.2 Manufacturer

**ZTE CORPORATION**

ZTE Plaza, Keji Road South, Hi-Tech, Industrial Park, Nanshan District, Shenzhen, Guangdong, 518057, P.R.China

## 1.3 Product Feature of Equipment Under Test

Product Feature	
<b>Equipment</b>	CDMA 1X & EVDO Dual-Mode Digital Mobile Phone
<b>Brand Name</b>	ZTE
<b>Model Name</b>	ZTE N817
<b>FCC ID</b>	SRQ-ZTEN817
<b>EUT supports Radios application</b>	CDMA/EV-DO/ WLAN 2.4GHz 802.11b/g/n HT20 Bluetooth v3.0 + EDR/Bluetooth v4.0 LE
<b>MEID Code</b>	Conducted: A000004E99191A Radiation: A000004E99198D ERP/EIRP: A000004E99198D
<b>HW Version</b>	2.0
<b>SW Version</b>	N817V1.0.0B01
<b>EUT Stage</b>	Identical Prototype

**Remark:** The above EUT's information was declared by manufacturer. Please refer to the specifications or user's manual for more detailed description.

## 1.4 Product Specification subjective to this standard

Product Specification subjective to this standard	
<b>Tx Frequency</b>	CDMA2000 BC0: 824.70 MHz ~ 848.31 MHz CDMA2000 BC1: 1851.25 MHz ~ 1908.75 MHz
<b>Rx Frequency</b>	CDMA2000 BC0: 869.70 MHz ~ 893.31 MHz CDMA2000 BC1: 1931.25 MHz ~ 1988.75 MHz
<b>Maximum Output Power to Antenna</b>	CDMA2000 BC0 : 24.14 dBm CDMA2000 BC1 : 23.95 dBm
<b>Antenna Type</b>	Fixed Internal Antenna
<b>Type of Modulation</b>	CDMA2000 : QPSK CDMA2000 1xEV-DO : QPSK/8PSK



### 1.5 Modification of EUT

No modifications are made to the EUT during all test items.

### 1.6 Maximum ERP/EIRP Power, Frequency Tolerance, and Emission Designator

FCC Rule	System	Type of Modulation	Maximum ERP/EIRP (W)	Frequency Tolerance (ppm)	Emission Designator
Part 22	CDMA2000 BC0 1xRTT	QPSK	0.1019	0.0072 ppm	1M28F9W
Part 24	CDMA2000 BC1 1xRTT	QPSK	0.2904	0.0048 ppm	1M27F9W



### 1.7 Testing Location

<b>Test Site</b>	SPORTON INTERNATIONAL (SHENZHEN) INC.	
<b>Test Site Location</b>	1F & 2F, Building A, Morning Business Center, No. 4003 ShiGu Rd., Xili Town, Nanshan District, Shenzhen, Guangdong, P. R. China TEL: +86-755-8637-9589 FAX: +86-755-8637-9595	
<b>Test Site No.</b>	<b>Sporton Site No.</b>	
	TH01-SZ	

<b>Test Site</b>	SPORTON INTERNATIONAL (SHENZHEN) INC.	
<b>Test Site Location</b>	No. 3 Building, the third floor of south, Shahe River west, Fengzeyuan warehouse, Nanshan District, Shenzhen, Guangdong, P. R. China TEL: +86-755- 3320-2398	
<b>Test Site No.</b>	<b>Sporton Site No.</b>	<b>FCC Registration No.</b>
	03CH01-SZ	831040

### 1.8 Applicable Standards

According to the specifications of the manufacturer, the EUT must comply with the requirements of the following standards:

- ♦ FCC 47 CFR Part 2, 22(H), 24(E)
- ♦ ANSI / TIA / EIA-603-C-2004
- ♦ FCC KDB 971168 D01 Power Meas. License Digital Systems v02r02

**Remark:**

1. All test items were verified and recorded according to the standards and without any deviation during the test.
2. This EUT has also been tested and complied with the requirements of FCC Part 15, Subpart B, recorded in a separate test report.



## 2 Test Configuration of Equipment Under Test

### 2.1 Test Mode

Antenna port conducted and radiated test items were performed according to KDB 971168 D01 Power Meas. License Digital Systems v02r02 with maximum output power.

Radiated measurements were performed with rotating EUT in different three orthogonal test planes to find the maximum emission.

Radiated emissions were investigated as following frequency range:

1. 30 MHz to 10th harmonic for CDMA2000 BC0.
2. 30 MHz to 10th harmonic for CDMA2000 BC1.

All modes and data rates and positions were investigated.

Test modes are chosen to be reported as the worst case configuration below:

Test Modes		
Band	Radiated TCs	Conducted TCs
CDMA2000 BC0	■ 1xRTT Link Mode	■ 1xRTT Link Mode
CDMA2000 BC1	■ 1xRTT Link Mode	■ 1xRTT Link Mode

#### Conducted Power Measurement Results:

Conducted Power (*Unit: dBm)						
Band	CDMA2000 BC0			CDMA2000 BC1		
Channel	1013	384	777	25	600	1175
Frequency	824.7	836.52	848.31	1851.25	1880	1908.75
1xRTT RC1 SO55	23.75	23.89	24.04	23.80	23.91	23.86
1xRTT RC3 SO55	23.88	23.97	24.14	23.88	23.95	23.89
1xRTT RC3 SO32(+ F-SCH)	23.75	23.95	23.96	23.82	23.88	23.85
1xRTT RC3 SO32(+SCH)	23.73	23.90	23.94	23.80	23.87	23.84
1xEV-DO RTAP 153.6kbps	23.87	23.95	24.13	23.90	23.92	23.91
1xEV-DO RETAP 4096Bits	23.86	23.94	24.06	23.86	23.91	23.90



## 2.2 Connection Diagram of Test System

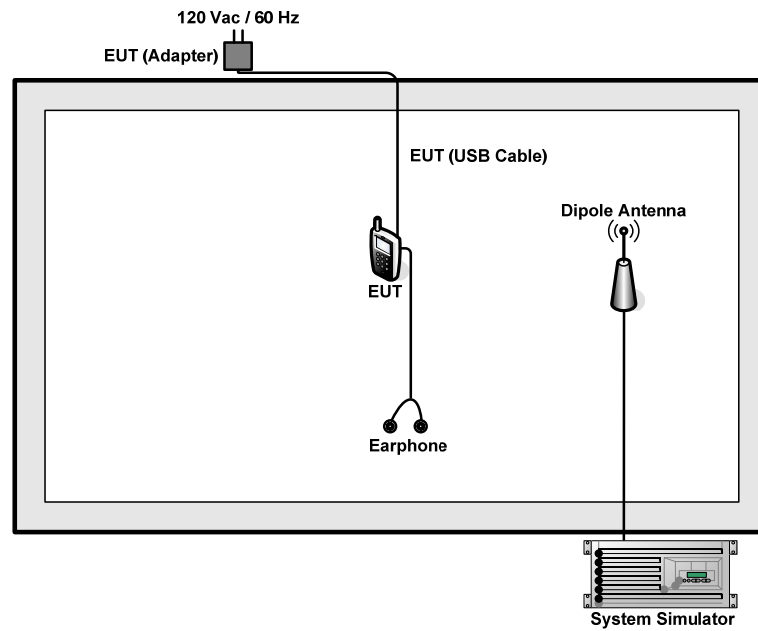

## 2.3 Support Unit used in test configuration

Item	Equipment	Trade Name	Model No.	FCC ID	Data Cable	Power Cord
1.	System Simulator	R&S	CMU 200	N/A	N/A	Unshielded, 1.8 m
2.	DC Power Supply	GW INSTEK	GPS-3030D	N/A	N/A	Unshielded, 1.8 m
3.	Earphone	Apple	MC690ZP/A	FCC Doc	N/A	N/A



## 2.4 Measurement Results Explanation Example

For all conducted test items:

The offset level is set in the spectrum analyzer to compensate the RF cable loss and attenuator factor between RF conducted output port and spectrum analyzer. With the offset compensation, the spectrum analyzer reading level will be exactly the RF output level.

The spectrum analyzer offset is derived from RF cable loss and attenuator factor.

*Offset = RF cable loss + attenuator factor.*

The following shows an offset computation example with RF cable loss 4.5 dB and a 10dB attenuator.

Example :

$$\begin{aligned} \text{Offset(dB)} &= \text{RF cable loss(dB)} + \text{attenuator factor(dB)} \\ &= 4.5 + 10 = 14.5 \text{ (dB)} \end{aligned}$$

### 3 Test Result

#### 3.1 Conducted Output Power Measurement

##### 3.1.1 Description of the Conducted Output Power Measurement

A system simulator was used to establish communication with the EUT. Its parameters were set to enforce EUT transmitting at the maximum power. The measured power in the radio frequency on the transmitter output terminals shall be reported.

##### 3.1.2 Measuring Instruments

The measuring equipment is listed in the section 4 of this test report.

##### 3.1.3 Test Procedures

1. The transmitter output port was connected to the system simulator.
2. Set EUT at maximum power through system simulator.
3. Select lowest, middle, and highest channels for each band and different modulation.
4. Measure the maximum burst average power for CDMA.

##### 3.1.4 Test Setup

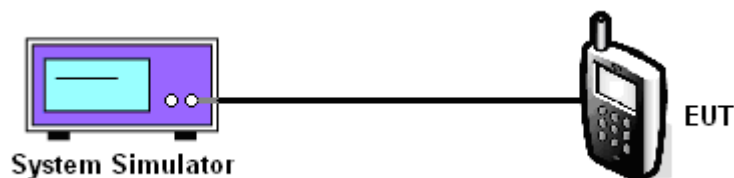



3.1.5 Test Result of Conducted Output Power

CDMA2000 BC0			
Test Mode	CDMA 2000 1xRTT		
Test Status	RC3+SO55		
Channel	1013 (Low)	384 (Mid)	777 (High)
Frequency (MHz)	824.70	836.52	848.31
Conducted Power (dBm)	23.88	23.97	24.14

CDMA2000 BC1			
Test Mode	CDMA 2000 1xRTT		
Test Status	RC3+SO55		
Channel	25 (Low)	600 (Mid)	1175 (High)
Frequency (MHz)	1851.25	1880.00	1908.75
Conducted Power (dBm)	23.88	23.95	23.89

Note: maximum average power for CDMA2000.

## 3.2 Peak-to-Average Ratio

### 3.2.1 Description of the PAR Measurement

The peak-to-average ratio (PAR) of the transmission may not exceed 13 dB.

### 3.2.2 Measuring Instruments

The measuring equipment is listed in the section 4 of this test report.

### 3.2.3 Test Procedures

1. The testing follows FCC KDB 971168 v02r02 Section 5.7.1.
2. The EUT was connected to the spectrum analyzer and system simulator via a power divider.
3. Set the CCDF (Complementary Cumulative Distribution Function) option on the spectrum analyzer.
4. The highest RF powers were measured and recorded the maximum PAPR level associated with a probability of 0.1 %.
5. Record the deviation as Peak to Average Ratio.

### 3.2.4 Test Setup

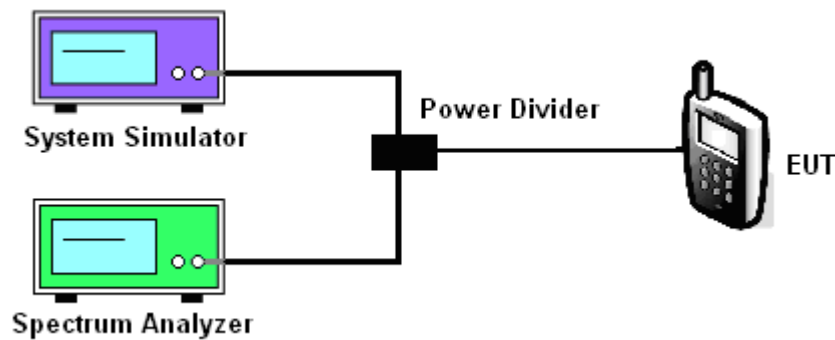



### 3.2.5 Test Result of Peak-to-Average Ratio

CDMA2000 BC0			
Modes	CDMA 2000 1xRTT		
Channel	1013 (Low)	384 (Mid)	777 (High)
Frequency (MHz)	824.70	836.52	848.31
Peak-to-Average Ratio (dB)	3.96	4.04	3.88

CDMA2000 BC1			
Modes	CDMA 2000 1xRTT		
Channel	25 (Low)	600 (Mid)	1175 (High)
Frequency (MHz)	1851.25	1880	1908.75
Peak-to-Average Ratio (dB)	4.04	4.04	3.76

### 3.2.6 Test Result (Plots) of Peak-to-Average Ratio

Band :	CDMA2000 BC0	Test Mode :	1xRTT Link (QPSK)
--------	--------------	-------------	-------------------

#### Peak-to-Average Ratio on Channel 1013 (824.70 MHz)

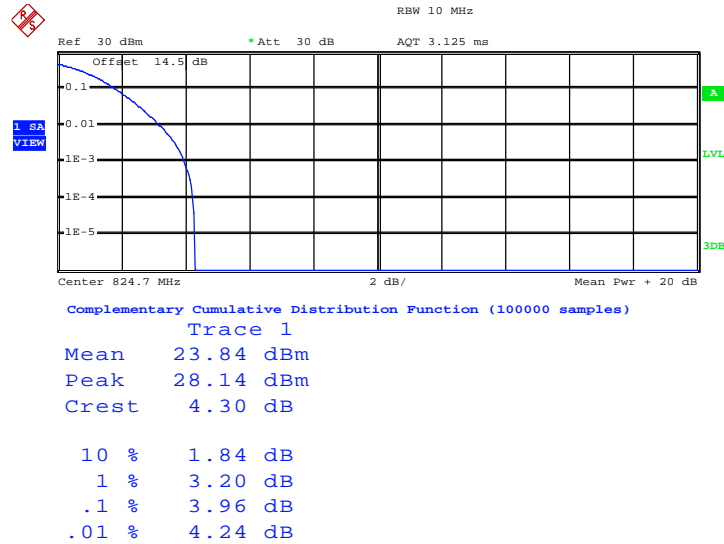

Date: 1.JUL.2015 15:22:14

#### Peak-to-Average Ratio on Channel 384 (836.52 MHz)

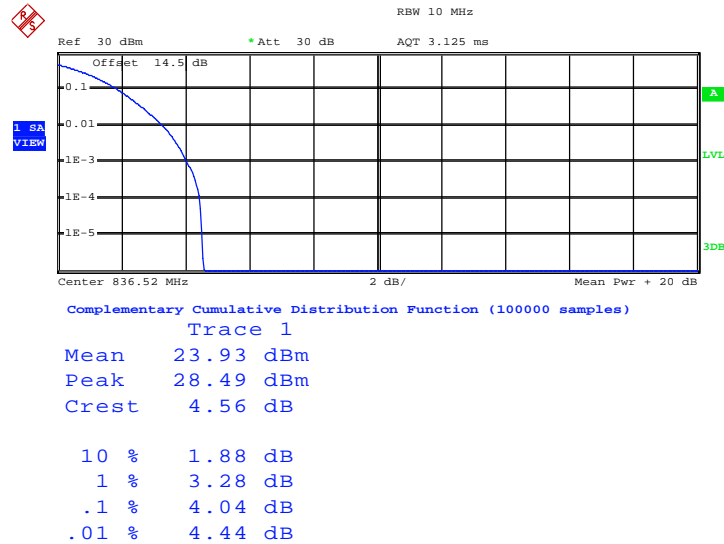

Date: 1.JUL.2015 15:22:34



Peak-to-Average Ratio on Channel 777 (848.31 MHz)

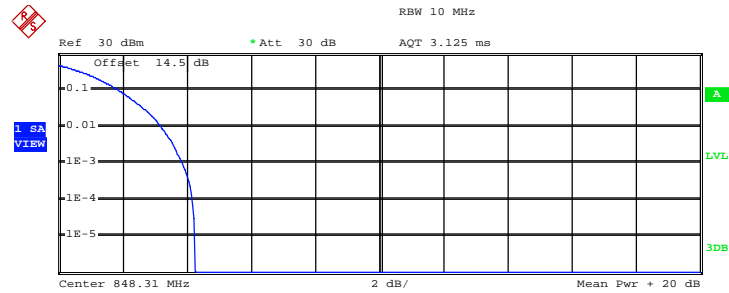

Complementary Cumulative Distribution Function (100000 samples)

Trace 1  
 Mean 24.09 dBm  
 Peak 28.35 dBm  
 Crest 4.26 dB

10 %	1.92 dB
1 %	3.20 dB
.1 %	3.88 dB
.01 %	4.20 dB

Date: 1.JUL.2015 15:22:53





<b>Band :</b>	CDMA2000 BC1	<b>Test Mode :</b>	1xRTT Link (QPSK)
---------------	--------------	--------------------	-------------------

Peak-to-Average Ratio on Channel 25 (1851.25 MHz)

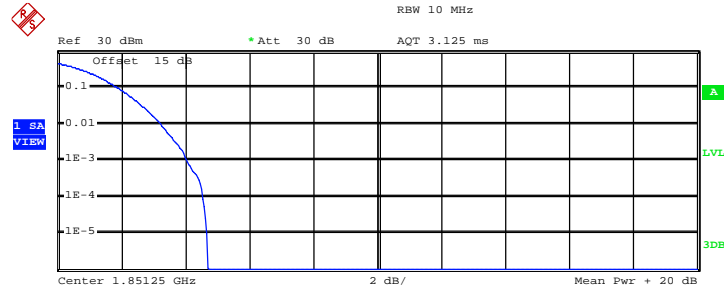

Complementary Cumulative Distribution Function (100000 samples)

Trace 1

Mean	23.66 dBm
Peak	28.35 dBm
Crest	4.69 dB
10 %	1.92 dB
1 %	3.24 dB
.1 %	4.04 dB
.01 %	4.56 dB

Date: 1.JUL.2015 17:15:30

Peak-to-Average Ratio on Channel 600 (1880 MHz)

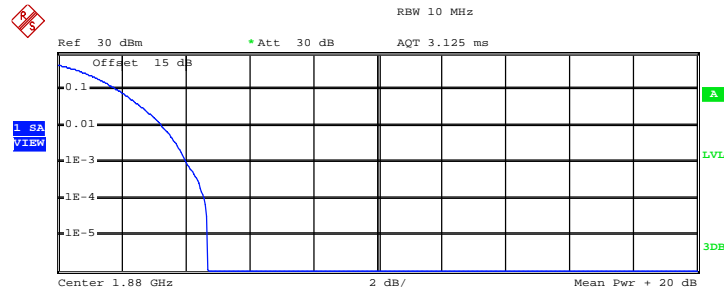

Complementary Cumulative Distribution Function (100000 samples)

Trace 1

Mean	23.64 dBm
Peak	28.35 dBm
Crest	4.71 dB
10 %	1.88 dB
1 %	3.28 dB
.1 %	4.04 dB
.01 %	4.60 dB

Date: 1.JUL.2015 17:15:48



Peak-to-Average Ratio on Channel 1175 (1908.75 MHz)

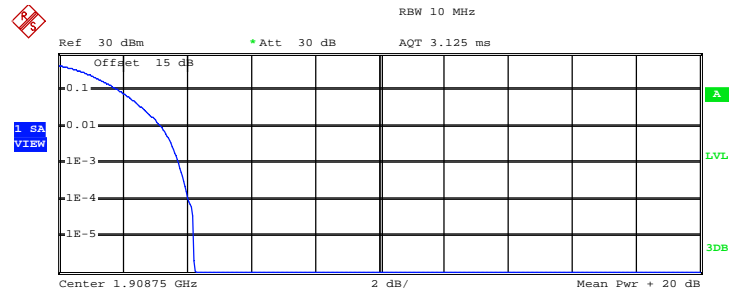

Complementary Cumulative Distribution Function (100000 samples)

Trace 1  
 Mean 23.69 dBm  
 Peak 27.93 dBm  
 Crest 4.23 dB

10 %	1.92 dB
1 %	3.20 dB
.1 %	3.76 dB
.01 %	4.08 dB

Date: 1.JUL.2015 17:16:07



### 3.3 Effective Radiated Power and Effective Isotropic Radiated Power Measurement

#### 3.3.1 Description of the ERP/EIRP Measurement

The substitution method, in ANSI / TIA / EIA-603-C-2004, was used for ERP/EIRP measurement, and the spectrum analyzer configuration follows KDB 971168 D01 Power Meas. License Digital Systems v02r02. The ERP of mobile transmitters must not exceed 7 Watts and the EIRP of mobile transmitters are limited to 2 Watts.

#### 3.3.2 Measuring Instruments

The measuring equipment is listed in the section 4 of this test report.

#### 3.3.3 Test Procedures

1. The testing follows FCC KDB 971168 v02r02 Section 5.2.1. (for CDMA/WCDMA), Section 5.2.2.2 (for GSM/GPRS/EDGE) and ANSI / TIA-603-C-2004 Section 2.2.17.
2. The EUT was placed on a non-conductive rotating platform 0.8 meters high in a semi-anechoic chamber. The radiated emission at the fundamental frequency was measured at 3 m with a test antenna and a spectrum analyzer with RMS detector per section 5. of KDB 971168 D01.
3. During the measurement, the system simulator parameters were set to force the EUT transmitting at maximum output power. The maximum emission was recorded from analyzer power level (LVL) from the 360 degrees rotation of the turntable and the test antenna raised and lowered over a range from 1 to 4 meters in both horizontally and vertically polarized orientations.
4. Effective Isotropic Radiated Power (EIRP) was measured by substitution method according to TIA/EIA-603-C. The EUT was replaced by the substitution antenna at same location, and then a known power from S.G. was applied into the dipole antenna through a Tx cable, and then recorded the maximum Analyzer reading through raised and lowered the test antenna. The correction factor (in dB) = S.G. - Tx Cable loss + Substitution antenna gain - Analyzer reading. Then the EUT's EIRP was calculated with the correction factor,  $EIRP = LVL + \text{Correction factor}$  and  $ERP = EIRP - 2.15$ . Take the record of the output power at substitution antenna.



	CDMA2000/EV-DO
SPAN	3MHz
RBW	30kHz
VBW	100kHz
Detector	RMS
Trace	Average
Average Type	Power
Sweep Count	100



3.3.4 Test Result of ERP

CDMA2000 BC0 1xRTT_RC3+SO55 Radiated Power ERP					
Channel	Frequency (MHz)	Horizontal		Vertical	
		ERP(dBm)	ERP(W)	ERP(dBm)	ERP(W)
Lowest	824.70	19.84	0.0964	3.35	0.0022
Middle	836.52	20.03	0.1007	3.47	0.0022
Highest	848.31	20.08	0.1019	3.69	0.0023
Limit	ERP < 7W	Result		PASS	

3.3.5 Test Result of EIRP

CDMA2000 BC1 1xRTT_RC3+SO55 Radiated Power EIRP					
Channel	Frequency (MHz)	Horizontal		Vertical	
		EIRP(dBm)	EIRP(W)	EIRP(dBm)	EIRP(W)
Lowest	1851.25	23.49	0.2234	23.53	0.2254
Middle	1880.00	24.21	0.2636	24.18	0.2618
Highest	1908.75	24.63	0.2904	24.38	0.2742
Limit	EIRP < 2W	Result		PASS	

## 3.4 99% Occupied Bandwidth and 26dB Bandwidth Measurement

### 3.4.1 Description of 99% Occupied Bandwidth and 26dB Bandwidth Measurement

The 99% occupied bandwidth is the width of a frequency band such that, below the lower and above the upper frequency limits, the mean powers emitted are each equal to a specified percentage 0.5% of the total mean transmitted power.

The emission bandwidth is defined as the width of the signal between two points, located at the 2 sides of the carrier frequency, outside of which all emissions are attenuated at least 26 dB below the transmitter power.

### 3.4.2 Measuring Instruments

The measuring equipment is listed in the section 4 of this test report.

### 3.4.3 Test Procedures

1. The testing follows FCC KDB 971168 v02r02 Section 4.2.
2. The EUT was connected to the spectrum analyzer and system simulator via a power divider.
3. The RF output of the EUT was connected to the spectrum analyzer by RF cable and attenuator. The path loss was compensated to the results for each measurement.
4. The 99% occupied bandwidth were measured, set RBW= 1% of span, VBW= 3\*RBW, peak detector, trace maximum hold.
5. The 26dB bandwidth were measured, set RBW= 1% of EBW, VBW= 3\*RBW, peak detector, trace maximum hold.

### 3.4.4 Test Setup

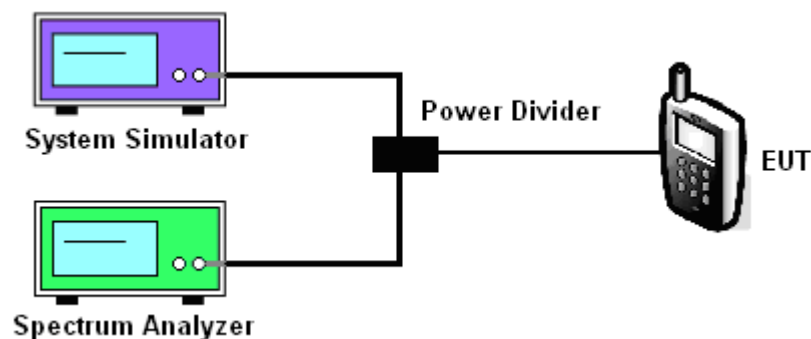



3.4.5 Test Result of Occupied Bandwidth and 26dB Bandwidth

CDMA2000 BC0			
Test Mode	CDMA 2000 1xRTT		
Test Status	RC3+SO55		
Channel	1013 (Low)	384 (Mid)	777 (High)
Frequency (MHz)	824.70	836.52	848.31
99% OBW (MHz)	1.276	1.270	1.274
26dB BW (MHz)	1.416	1.414	1.416

CDMA2000 BC1			
Test Mode	CDMA 2000 1xRTT		
Test Status	RC3+SO55		
Channel	25 (Low)	600 (Mid)	1175 (High)
Frequency (MHz)	1851.25	1880.00	1908.75
99% OBW (MHz)	1.274	1.274	1.274
26dB BW (MHz)	1.412	1.422	1.418



### 3.4.6 Test Result (Plots) of Occupied Bandwidth and 26dB Bandwidth

Band :	CDMA2000 BC0	Test Mode :	1xRTT_RC3+SO55 (QPSK)
--------	--------------	-------------	-----------------------

99% Occupied Bandwidth Plot on Channel 1013 (824.7 MHz)

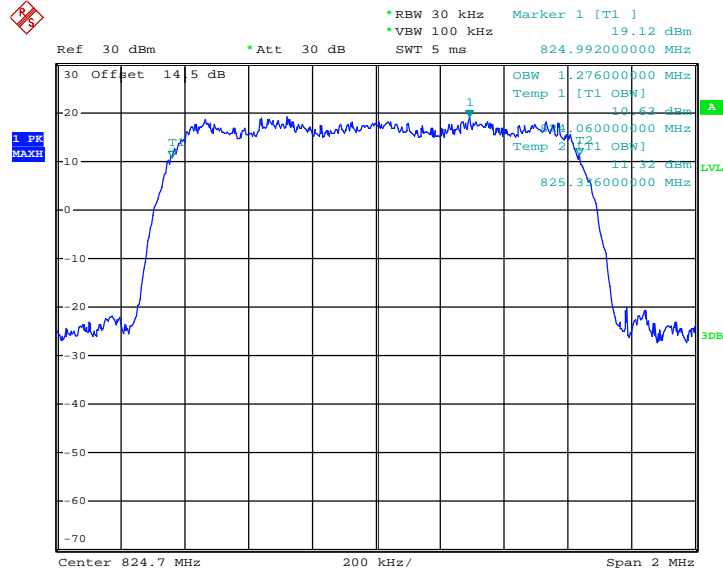

Date: 1.JUL.2015 15:19:15

26dB Bandwidth Plot on Channel 1013 (824.7 MHz)

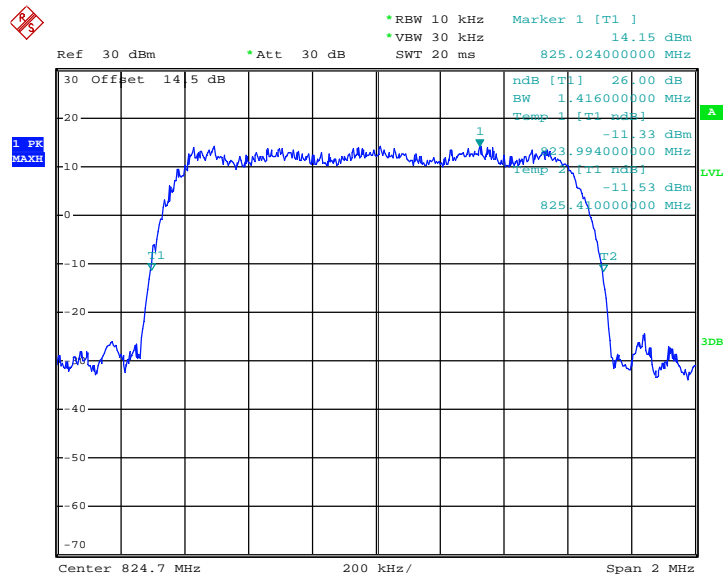

Date: 1.JUL.2015 15:16:57





99% Occupied Bandwidth Plot on Channel 384 (836.52 MHz)

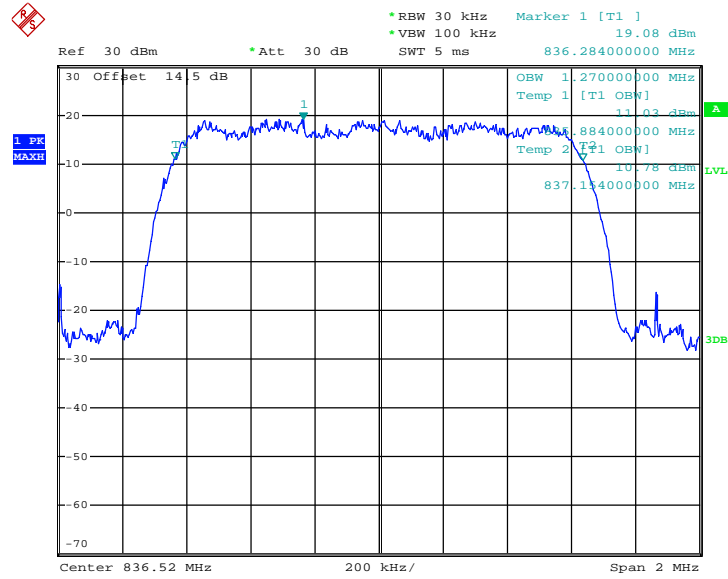

Date: 1.JUL.2015 15:20:33

26dB Bandwidth Plot on Channel 384 (836.52 MHz)

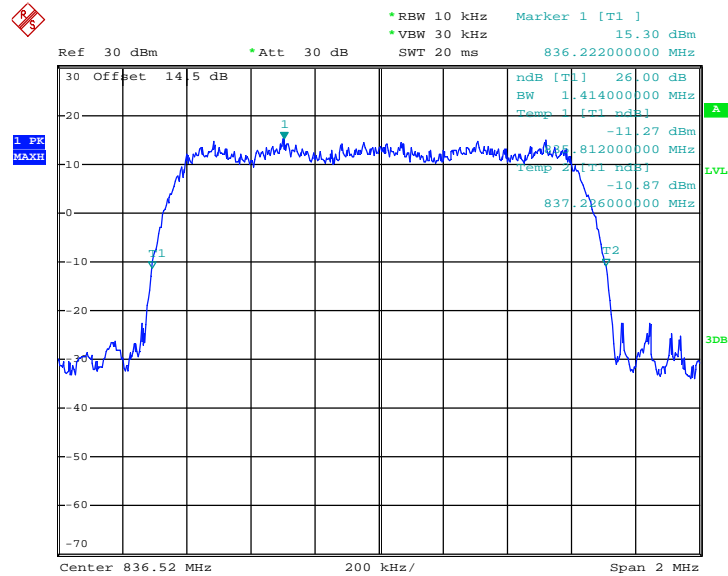

Date: 1.JUL.2015 15:17:41



99% Occupied Bandwidth Plot on Channel 777 (848.31 MHz)

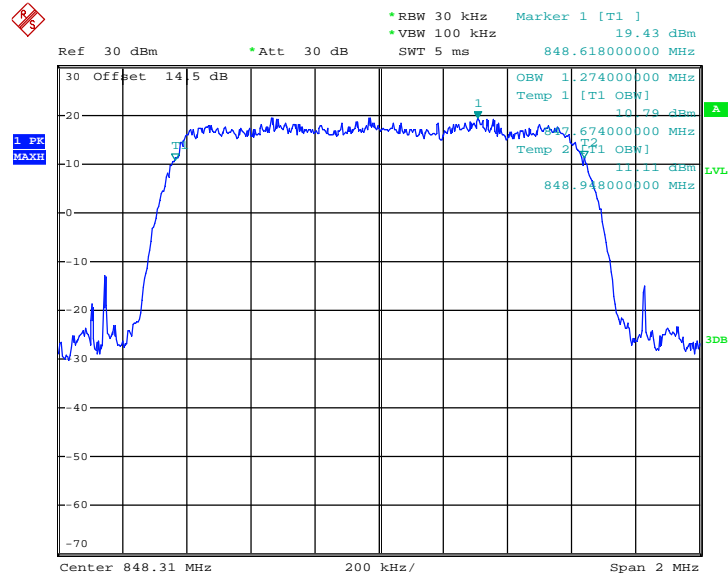

Date: 1.JUL.2015 15:21:42

26dB Bandwidth Plot on Channel 777 (848.31 MHz)

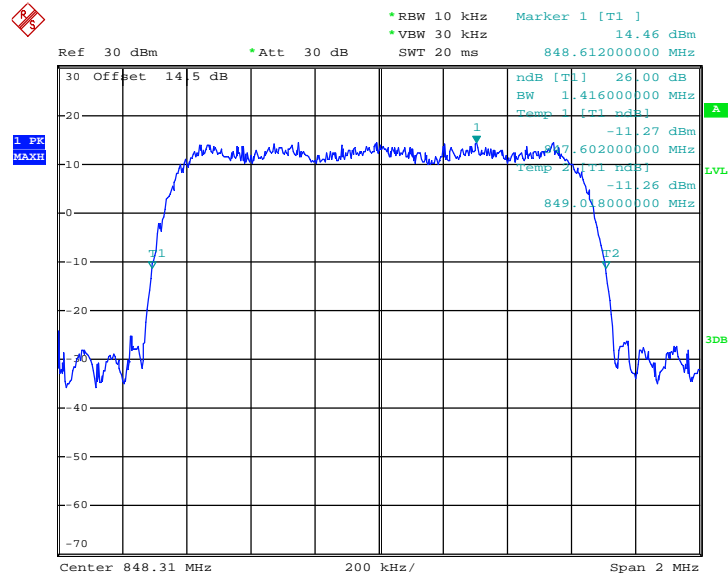

Date: 1.JUL.2015 15:18:24



<b>Band :</b>	CDMA2000 BC1	<b>Test Mode :</b>	1xRTT_RC3+SO55 (QPSK)
---------------	--------------	--------------------	-----------------------

99% Occupied Bandwidth Plot on Channel 25 (1851.25 MHz)

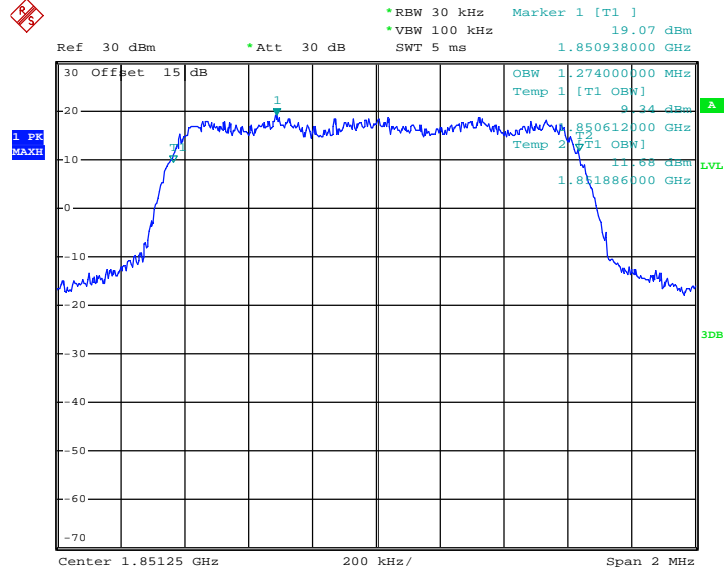

Date: 1.JUL.2015 17:06:05

26dB Bandwidth Plot on Channel 25 (1851.25 MHz)

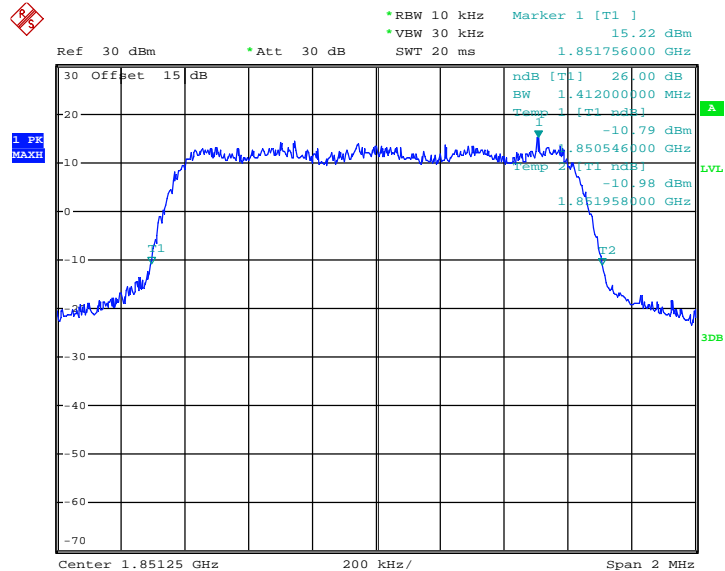

Date: 1.JUL.2015 15:47:17



99% Occupied Bandwidth Plot on Channel 600 (1880.0 MHz)

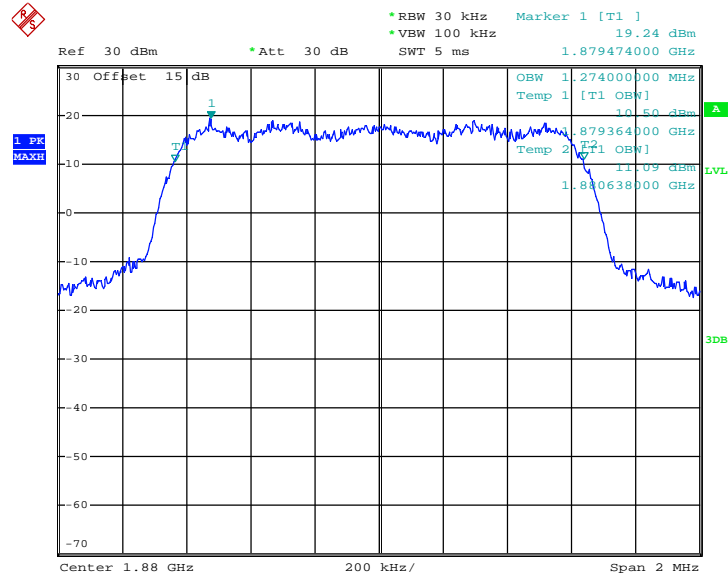

Date: 1.JUL.2015 17:06:38

26dB Bandwidth Plot on Channel 600 (1880.0 MHz)

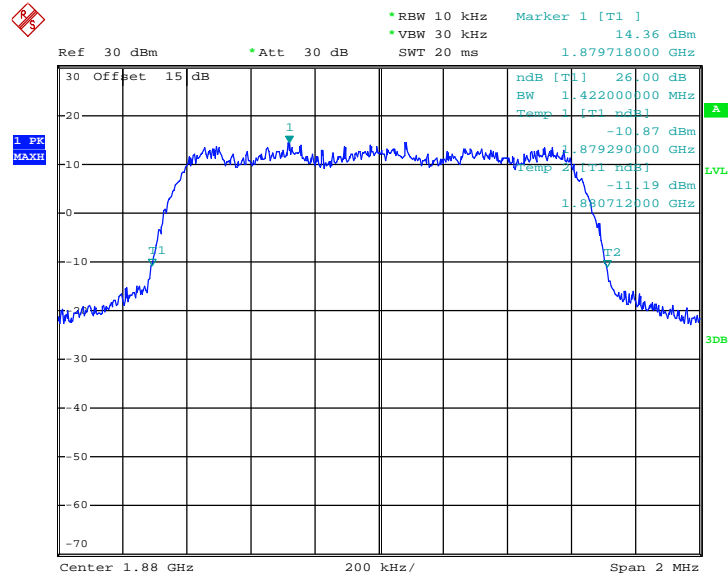

Date: 1.JUL.2015 16:01:38



### 99% Occupied Bandwidth Plot on Channel 1175 (1908.75 MHz)

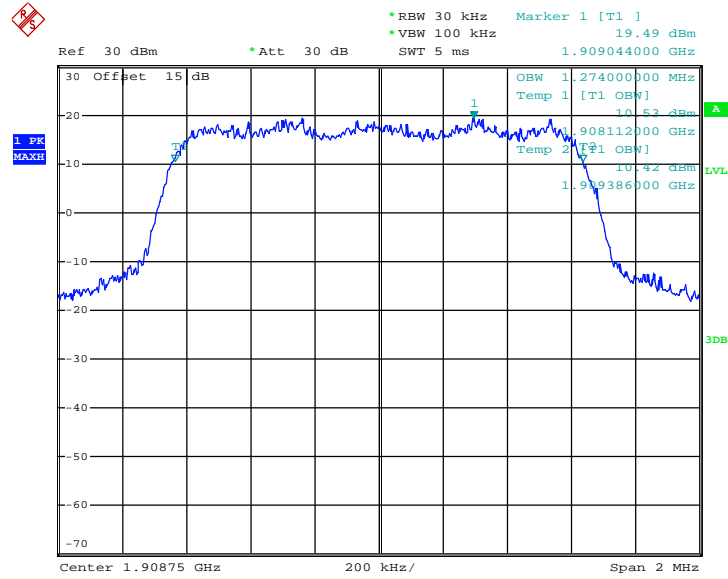

Date: 1.JUL.2015 17:08:11

### 26dB Bandwidth Plot on Channel 1175 (1908.75 MHz)

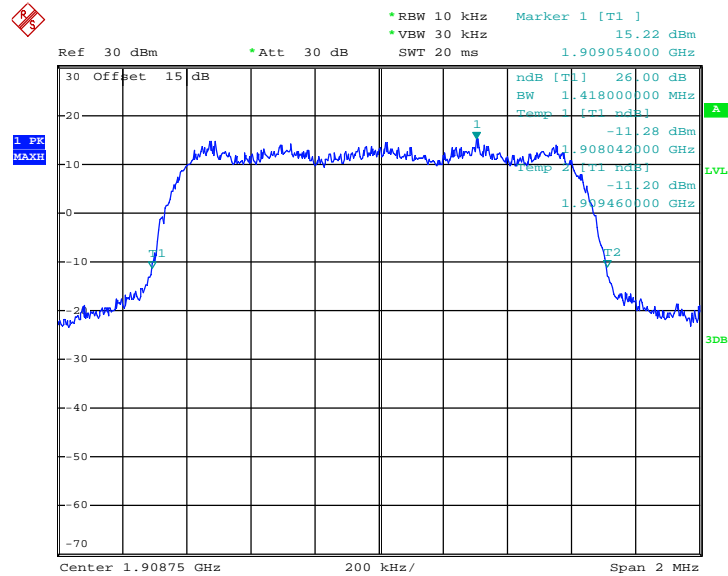

Date: 1.JUL.2015 16:02:18

## 3.5 Band Edge Measurement

### 3.5.1 Description of Band Edge Measurement

The power of any emission outside of the authorized operating frequency ranges must be lower than the transmitter power (P) by a factor of at least  $43 + 10 \log (P)$  dB.

### 3.5.2 Measuring Instruments

The measuring equipment is listed in the section 4 of this test report.

### 3.5.3 Test Procedures

1. The testing follows FCC KDB 971168 v02r02 Section 6.0.
2. The EUT was connected to the spectrum analyzer and system simulator via a power divider.
3. The RF output of EUT was connected to the spectrum analyzer by an RF cable and attenuator. The path loss was compensated to the results for each measurement.
4. The band edges of low and high channels for the highest RF powers were measured.
5. The RF fundamental frequency should be excluded against the limit line in the operating frequency band.
6. The limit line is derived from  $43 + 10\log(P)$  dB below the transmitter power P(Watts)  
 $= P(W) - [43 + 10\log(P)] \text{ (dB)}$   
 $= [30 + 10\log(P)] \text{ (dBm)} - [43 + 10\log(P)] \text{ (dB)}$   
 $= -13\text{dBm}.$

### 3.5.4 Test Setup

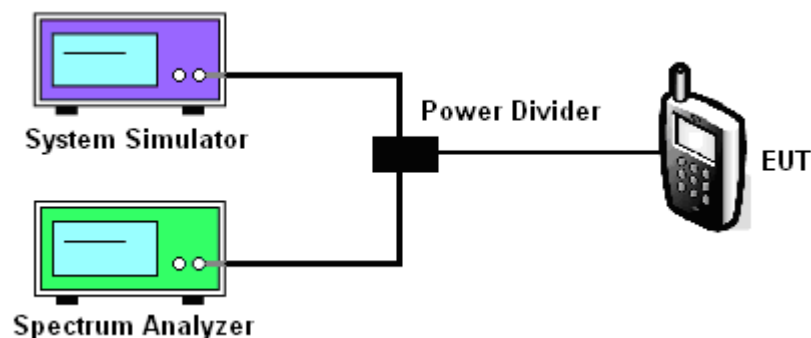



### 3.5.5 Test Result (Plots) of Conducted Band Edge

Band :	CDMA2000 BC0	Test Mode :	1xRTT_RC3+SO55 (QPSK)
--------	--------------	-------------	-----------------------

Lower Band Edge Plot on Channel 1013 (824.7 MHz)

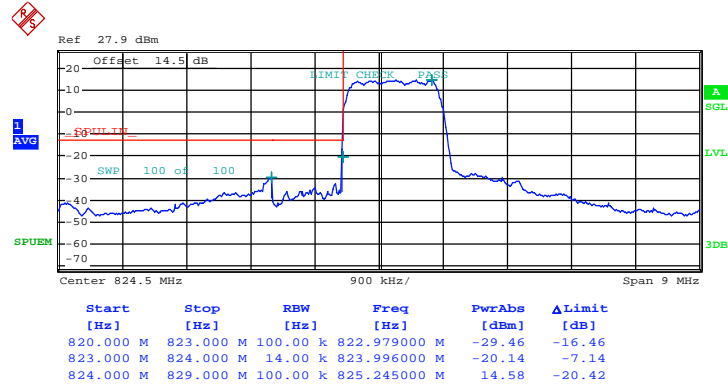

Date: 1.JUL.2015 18:10:02



Band :	CDMA2000 BC0	Test Mode :	1xRTT_RC3+SO55 (QPSK)
--------	--------------	-------------	-----------------------

Higher Band Edge Plot on Channel 777 (848.31 MHz)

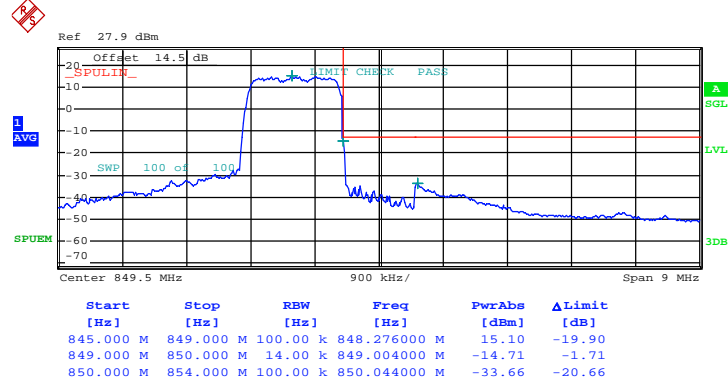

Date: 1.JUL.2015 18:06:44





<b>Band :</b>	CDMA2000 BC1	<b>Test Mode :</b>	1xRTT_RC3+SO55 (QPSK)
---------------	--------------	--------------------	-----------------------

Lower Band Edge Plot on Channel 25 (1851.25 MHz)

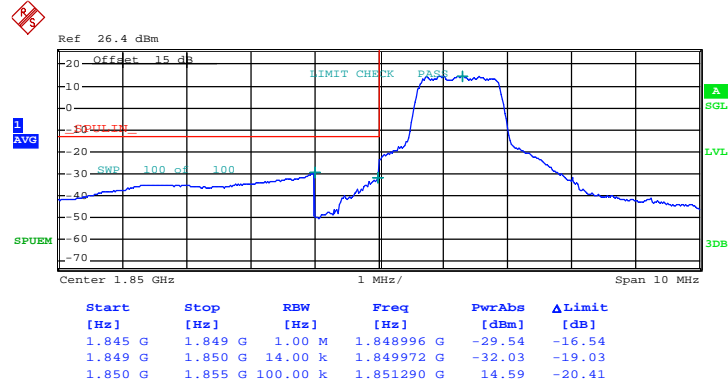

Date: 1.JUL.2015 17:49:14



Band :	CDMA2000 BC1	Test Mode :	1xRTT_RC3+SO55 (QPSK)
--------	--------------	-------------	-----------------------

Higher Band Edge Plot on Channel 1175 (1908.75 MHz)

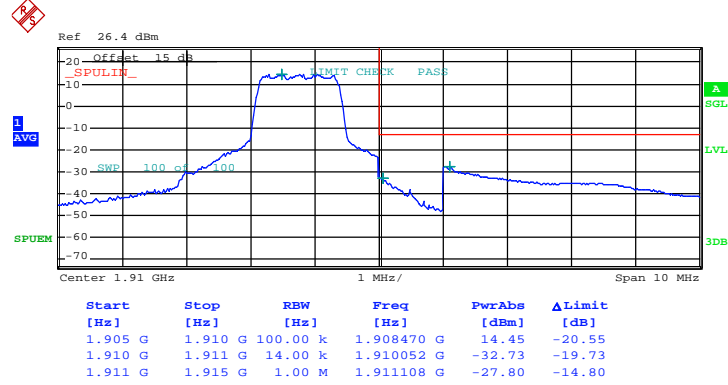

Date: 1.JUL.2015 17:43:02

## 3.6 Conducted Spurious Emission Measurement

### 3.6.1 Description of Conducted Spurious Emission Measurement

The power of any emission outside of the authorized operating frequency ranges must be lower than the transmitter power (P) by a factor of at least  $43 + 10 \log (P)$  dB.

It is measured by means of a calibrated spectrum analyzer and scanned from 30 MHz up to a frequency including its 10<sup>th</sup> harmonic.

### 3.6.2 Measuring Instruments

The measuring equipment is listed in the section 4 of this test report.

### 3.6.3 Test Procedures

1. The testing follows FCC KDB 971168 v02r02 Section 6.0.
2. The EUT was connected to the spectrum analyzer and system simulator via a power divider.
3. The RF output of EUT was connected to the spectrum analyzer by an RF cable and attenuator. The path loss was compensated to the results for each measurement.
4. The middle channel for the highest RF power within the transmitting frequency was measured.
5. The conducted spurious emission for the whole frequency range was taken.
6. The RF fundamental frequency should be excluded against the limit line in the operating frequency band.
7. The limit line is derived from  $43 + 10\log(P)$  dB below the transmitter power P(Watts)  
 $= P(W) - [43 + 10\log(P)]$  (dB)  
 $= [30 + 10\log(P)]$  (dBm) -  $[43 + 10\log(P)]$  (dB)  
 $= -13\text{dBm}$ .

### 3.6.4 Test Setup

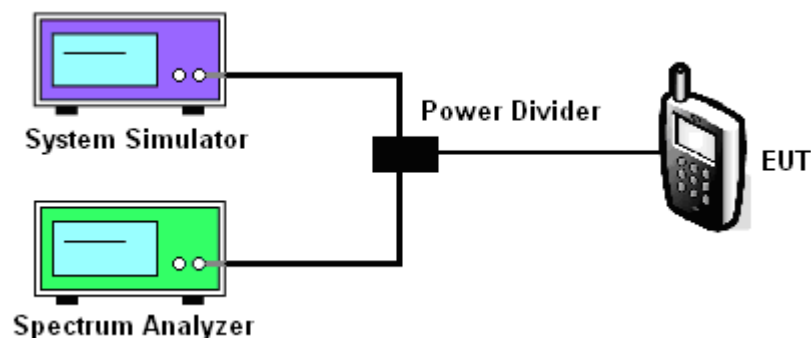



3.6.5 Test Result (Plots) of Conducted Spurious Emission

Band :	CDMA2000 BC0	Channel :	CH384
Test Mode :	1xRTT_RC3+SO55 (QPSK)	Frequency :	836.52 MHz

Conducted Spurious Emission Plot between 30MHz ~ 9GHz

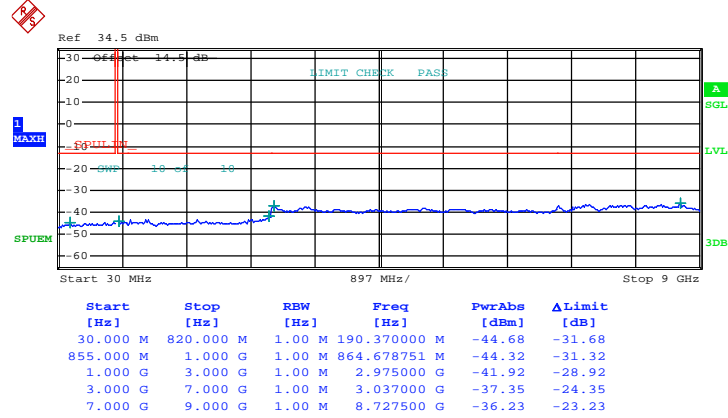

Date: 1.JUL.2015 15:27:47



<b>Band :</b>	CDMA2000 BC1	<b>Channel :</b>	CH600
<b>Test Mode :</b>	1xRTT_RC3+SO55 (QPSK)	<b>Frequency :</b>	1880.0 MHz

**Conducted Spurious Emission Plot between 30MHz ~ 19.1GHz**

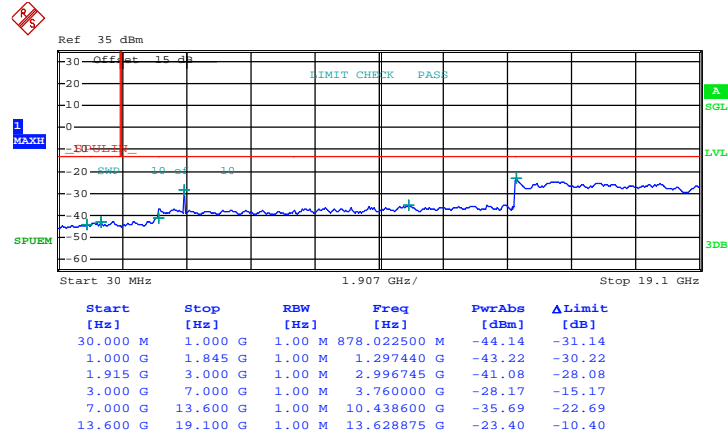

Date: 1.JUL.2015 17:17:52



## 3.7 Field Strength of Spurious Radiation Measurement

### 3.7.1 Description of Field Strength of Spurious Radiated Measurement

The power of any emission outside of the authorized operating frequency ranges must be attenuated below the transmitter power (P) by a factor of at least  $43 + 10 \log (P)$  dB. The spectrum is scanned from 30 MHz up to a frequency including its 10th harmonic.

### 3.7.2 Measuring Instruments

The measuring equipment is listed in the section 4 of this test report.

### 3.7.3 Test Procedures

1. The testing follows FCC KDB 971168 v02r02 Section 5.8 and ANSI / TIA-603-C-2004 Section 2.2.12.
2. The EUT was placed on a rotatable wooden table 0.8 meters above the ground.
3. The EUT was set 3 meters from the receiving antenna, which was mounted on the antenna tower.
4. The table was rotated 360 degrees to determine the position of the highest spurious emission.
5. The height of the receiving antenna is varied between one meter and four meters to search for the maximum spurious emission for both horizontal and vertical polarizations.
6. Make the measurement with the spectrum analyzer's RBW = 1MHz, VBW = 3MHz, taking record of maximum spurious emission.
7. A horn antenna was substituted in place of the EUT and was driven by a signal generator.
8. Tune the output power of signal generator to the same emission level with EUT maximum spurious emission.
9. Taking the record of output power at antenna port.
10. Repeat step 7 to step 8 for another polarization.
11.  $EIRP \text{ (dBm)} = S.G. \text{ Power} - Tx \text{ Cable Loss} + Tx \text{ Antenna Gain}$
12.  $ERP \text{ (dBm)} = EIRP - 2.15$
13. The RF fundamental frequency should be excluded against the limit line in the operating frequency band.
14. The limit line is derived from  $43 + 10\log(P)$  dB below the transmitter power P(Watts)  
 $= P(W) - [43 + 10\log(P)] \text{ (dB)}$   
 $= [30 + 10\log(P)] \text{ (dBm)} - [43 + 10\log(P)] \text{ (dB)}$   
 $= -13\text{dBm}.$

### 3.7.4 Test Setup

For radiated emissions from 30MHz to 1GHz

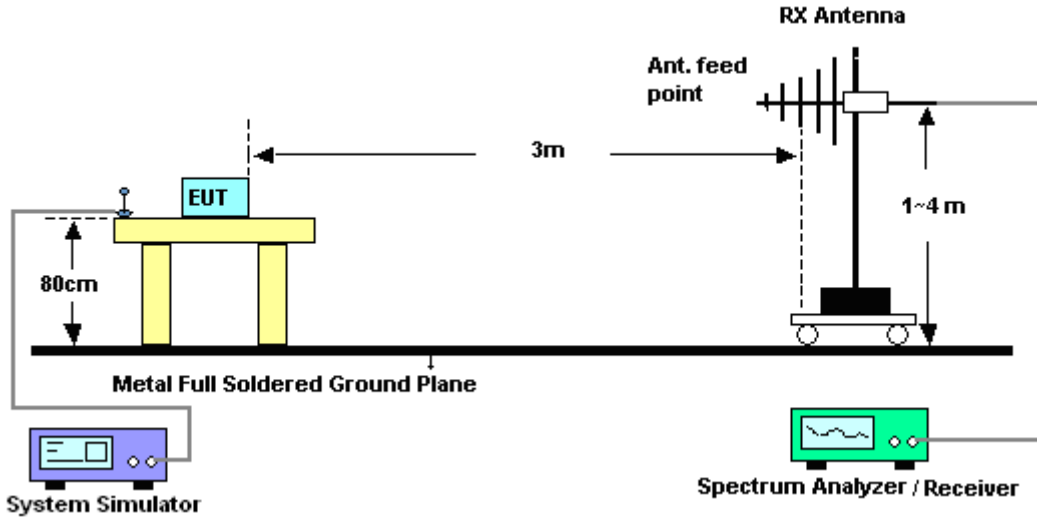

For radiated emissions above 1GHz

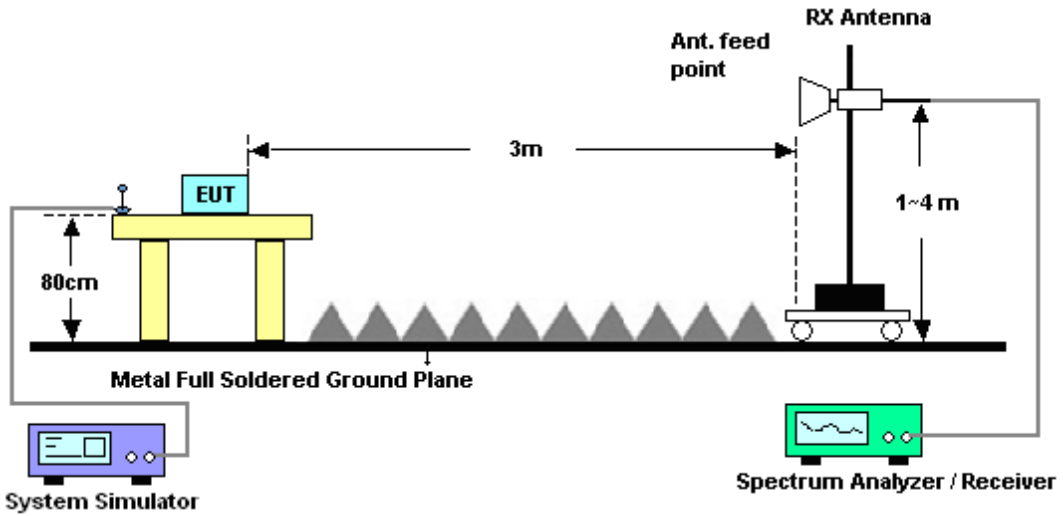



3.7.5 Test Result of Field Strength of Spurious Radiated

<b>Band :</b>	CDMA2000 BC0					<b>Temperature :</b>	23~25°C		
<b>Test Mode :</b>	1xRTT_RC3+SO55 (QPSK)					<b>Relative Humidity :</b>	48~52%		
<b>Test Engineer :</b>	Jeff Yao					<b>Polarization :</b>	Horizontal		
<b>Remark :</b>	Spurious emissions within 30-1000MHz were found more than 20dB below limit line.								
Frequency ( MHz )	ERP ( dBm )	Limit ( dBm )	Over Limit ( dB )	SPA Reading ( dBm )	S.G. Power ( dBm )	TX Cable loss ( dB )	TX Antenna Gain ( dBi )	Polarization ( H/V )	Result
1673.04	-37.61	-13	-24.61	-54.41	-40.58	0.88	6.00	H	Pass
2509.56	-46.62	-13	-33.62	-69.29	-49.23	1.08	5.84	H	Pass
3346.08	-57.86	-13	-44.86	-68.46	-62.23	1.14	7.66	H	Pass

<b>Band :</b>	CDMA2000 BC0					<b>Temperature :</b>	23~25°C		
<b>Test Mode :</b>	1xRTT_RC3+SO55 (QPSK)					<b>Relative Humidity :</b>	48~52%		
<b>Test Engineer :</b>	Jeff Yao					<b>Polarization :</b>	Vertical		
<b>Remark :</b>	Spurious emissions within 30-1000MHz were found more than 20dB below limit line.								
Frequency ( MHz )	ERP ( dBm )	Limit ( dBm )	Over Limit ( dB )	SPA Reading ( dBm )	S.G. Power ( dBm )	TX Cable loss ( dB )	TX Antenna Gain ( dBi )	Polarization ( H/V )	Result
1673.04	-42.31	-13	-29.31	-55.75	-45.28	0.88	6.00	V	Pass
2509.56	-48.80	-13	-35.80	-69.12	-51.41	1.08	5.84	V	Pass
3346.08	-57.86	-13	-44.86	-69.69	-62.23	1.14	7.66	V	Pass





<b>Band :</b>	CDMA2000 BC1						<b>Temperature :</b>	23~25°C	
<b>Test Mode :</b>	1xRTT_RC3+S055 (QPSK)						<b>Relative Humidity :</b>	48~52%	
<b>Test Engineer :</b>	Jeff Yao						<b>Polarization :</b>	Horizontal	
<b>Remark :</b>	Spurious emissions within 30-1000MHz were found more than 20dB below limit line.								
Frequency ( MHz )	EIRP ( dBm )	Limit ( dBm )	Over Limit ( dB )	SPA Reading ( dBm )	S.G. Power ( dBm )	TX Cable loss ( dB )	TX Antenna Gain ( dBi )	Polarization ( H/V )	Result
3760	-35.83	-13	-22.83	-52.71	-42.57	1.28	8.02	H	Pass
5640	-51.86	-13	-38.86	-69.85	-60.28	1.58	10.00	H	Pass
7520	-48.86	-13	-35.86	-70.80	-59.18	1.78	12.10	H	Pass

<b>Band :</b>	CDMA2000 BC1						<b>Temperature :</b>	23~25°C	
<b>Test Mode :</b>	1xRTT_RC3+S055 (QPSK)						<b>Relative Humidity :</b>	48~52%	
<b>Test Engineer :</b>	Jeff Yao						<b>Polarization :</b>	Vertical	
<b>Remark :</b>	Spurious emissions within 30-1000MHz were found more than 20dB below limit line.								
Frequency ( MHz )	EIRP ( dBm )	Limit ( dBm )	Over Limit ( dB )	SPA Reading ( dBm )	S.G. Power ( dBm )	TX Cable loss ( dB )	TX Antenna Gain ( dBi )	Polarization ( H/V )	Result
3760	-36.74	-13	-23.74	-54.49	-43.48	1.28	8.02	V	Pass
5640	-53.12	-13	-40.12	-70.2	-61.54	1.58	10	V	Pass
7520	-49.14	-13	-36.14	-71.39	-59.46	1.78	12.1	V	Pass

## 3.8 Frequency Stability Measurement

### 3.8.1 Description of Frequency Stability Measurement

The frequency stability shall be measured by variation of ambient temperature and variation of primary supply voltage to ensure that the fundamental emission stays within the authorized frequency block. The frequency stability of the transmitter shall be maintained within  $\pm 0.00025\%$  ( $\pm 2.5\text{ppm}$ ) of the center frequency.

### 3.8.2 Measuring Instruments

The measuring equipment is listed in the section 4 of this test report.

### 3.8.3 Test Procedures for Temperature Variation

1. The testing follows FCC KDB 971168 v02r02 Section 9.0.
2. The EUT was set up in the thermal chamber and connected with the system simulator.
3. With power OFF, the temperature was decreased to  $-30^{\circ}\text{C}$  and the EUT was stabilized before testing. Power was applied and the maximum change in frequency was recorded within one minute.
4. With power OFF, the temperature was raised in  $10^{\circ}\text{C}$  steps up to  $50^{\circ}\text{C}$ . The EUT was stabilized at each step for at least half an hour. Power was applied and the maximum frequency change was recorded within one minute.

### 3.8.4 Test Procedures for Voltage Variation

1. The testing follows FCC KDB 971168 v02r02 Section 9.0.
2. The EUT was placed in a temperature chamber at  $25\pm 5^{\circ}\text{C}$  and connected with the system simulator.
3. The power supply voltage to the EUT was varied from BEP to 115% of the nominal value measured at the input to the EUT.
4. The variation in frequency was measured for the worst case.

### 3.8.5 Test Setup

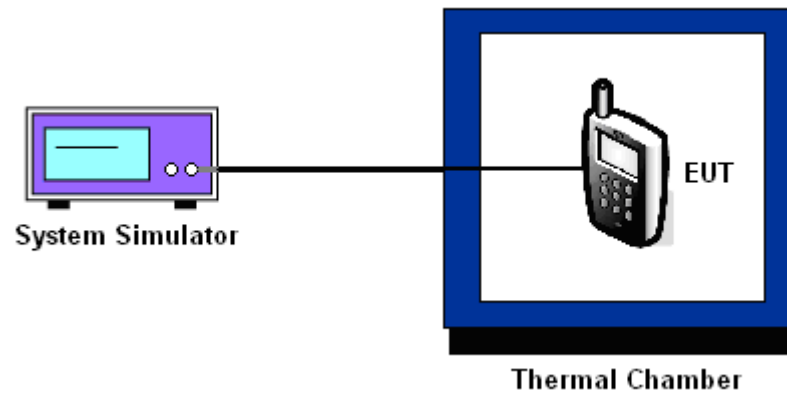



3.8.6 Test Result of Temperature Variation

<b>Band :</b>	CDMA2000 BC0 1xRTT_RC3+SO55	<b>Channel :</b>	384
<b>Limit (ppm) :</b>	2.5	<b>Frequency :</b>	836.52 MHz

Temperature (°C)	Deviation (ppm)	Result
50	0.0072	PASS
40	0.0036	
30	0.0024	
20(Ref.)	0.0000	
10	0.0012	
0	0.0012	
-10	0.0036	
-20	0.0024	
-30	0.0060	

<b>Band :</b>	CDMA2000 BC1 1xRTT_RC3+SO55	<b>Channel :</b>	600
<b>Limit (ppm) :</b>	within authorized band	<b>Frequency :</b>	1880.0 MHz

Temperature (°C)	Deviation (ppm)	Result
50	0.0027	PASS
40	0.0005	
30	0.0016	
20(Ref.)	0.0000	
10	0.0011	
0	0.0011	
-10	0.0005	
-20	0.0027	
-30	0.0048	

Note: The frequency fundamental emissions stay within the authorized frequency block based on the frequency deviation measured is small.



3.8.7 Test Result of Voltage Variation

Band & Channel	Mode	Voltage (Volt)	Deviation (ppm)	Limit (ppm)	Result
CDMA2000 BC0 CH384	1xRTT RC3+SO55	3.7	0.0000	2.5	Pass
		BEP	0.0012		
		4.2	0.0024		
CDMA2000 BC1 CH600	1xRTT RC3+SO55	3.7	0.0000	(Note 3.)	
		BEP	0.0011		
		4.2	0.0011		

Note:

1. Normal Voltage = 3.7V.
2. Battery End Point (BEP) = 3.6 V.
3. The frequency fundamental emissions stay within the authorized frequency block based on the frequency deviation measured is small.



## 4 List of Measuring Equipment

Instrument	Manufacturer	Model No.	Serial No.	Characteristics	Calibration Date	Test Date	Due Date	Remark
Spectrum Analyzer	R&S	FSP30	101400	9kHz~30GHz	Jan. 28, 2015	Jul. 01, 2015	Jan. 27, 2016	Conducted (TH01-SZ)
Thermal Chamber	Ten Billion Hongzhangroup	LP-150U	H2014081803	-40~+150°C	Sep. 16, 2014	Jul. 01, 2015	Sep. 15, 2015	Conducted (TH01-SZ)
EMI Test Receiver&SA	Agilent Technologies	N9038A	MY52260185	20Hz~26.5GHz	May 26, 2015	Jul. 09, 2015~ Jul. 10, 2015	May 25, 2016	Radiation (03CH01-SZ)
Spectrum Analyzer	R&S	FSV40	101041	10kHz~40GHz;Max x 30dBm	Sep. 25, 2014	Jul. 09, 2015~ Jul. 10, 2015	Sep. 24, 2015	Radiation (03CH01-SZ)
Bilog Antenna	TeseQ	CBL6112D	23188	30MHz~2GHz	Nov. 07, 2014	Jul. 09, 2015~ Jul. 10, 2015	Nov. 06, 2015	Radiation (03CH01-SZ)
Double Ridge Horn Antenna	ETS-Lindgren	3117	00119436	1GHz~18GHz	Oct. 15, 2014	Jul. 09, 2015~ Jul. 10, 2015	Oct. 14, 2015	Radiation (03CH01-SZ)
SHF-EHF Horn	com-power	AH-840	101071	18GHz~40GHz	Sep. 04, 2014	Jul. 09, 2015~ Jul. 10, 2015	Sep. 03, 2015	Radiation (03CH01-SZ)
Amplifier	ADVANTEST	BB525C	E9007003	9kHz~3000MHz / 30 dB	Jan. 28, 2015	Jul. 09, 2015~ Jul. 10, 2015	Jan. 27, 2016	Radiation (03CH01-SZ)
Amplifier	Yiai	AV3860B	04030	2GHz~26.5GHz	May 05, 2015	Jul. 09, 2015~ Jul. 10, 2015	May 04, 2016	Radiation (03CH01-SZ)
Amplifier	Agilent Technologies	83017A	MY39501302	500MHz~26.5GHz	Jan. 28, 2015	Jul. 09, 2015~ Jul. 10, 2015	Jan. 27, 2016	Radiation (03CH01-SZ)
AC Power Source	Chroma	61601	61601000198 5	N/A	NCR	Jul. 09, 2015~ Jul. 10, 2015	NCR	Radiation (03CH01-SZ)
Turn Table	EM	EM1000	N/A	0~360 degree	NCR	Jul. 09, 2015~ Jul. 10, 2015	NCR	Radiation (03CH01-SZ)
Antenna Mast	EM	EM1000	N/A	1 m~4 m	NCR	Jul. 09, 2015~ Jul. 10, 2015	NCR	Radiation (03CH01-SZ)



## 5 Uncertainty of Evaluation

### Uncertainty of Radiated Emission Measurement (30 MHz ~ 1000 MHz)

Measuring Uncertainty for a Level of Confidence of 95% ( $U = 2Uc(y)$ )	3.9dB
---	-------