

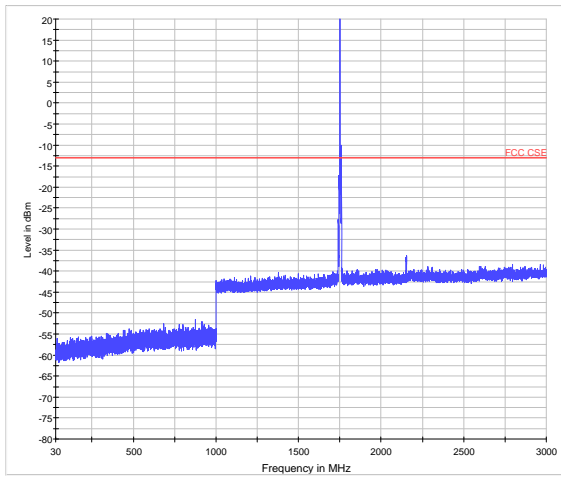

LTE Band 4 5MHz CH-High 30MHz~3GHz

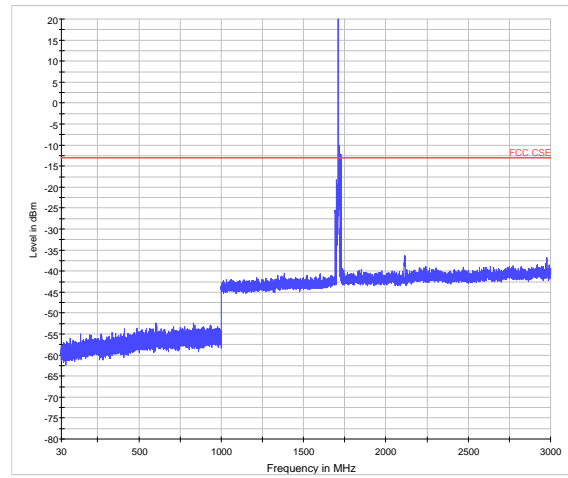

LTE Band 4 10MHz CH-Low 30MHz~3GHz



LTE Band 4 5MHz CH-High 3GHz~18GHz

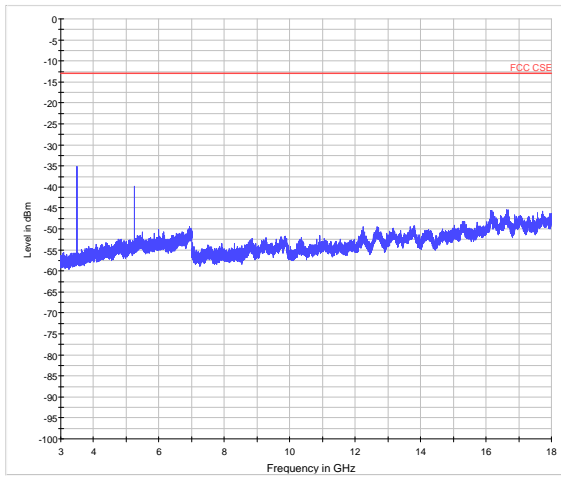

LTE Band 4 10MHz CH-Low 3GHz~18GHz

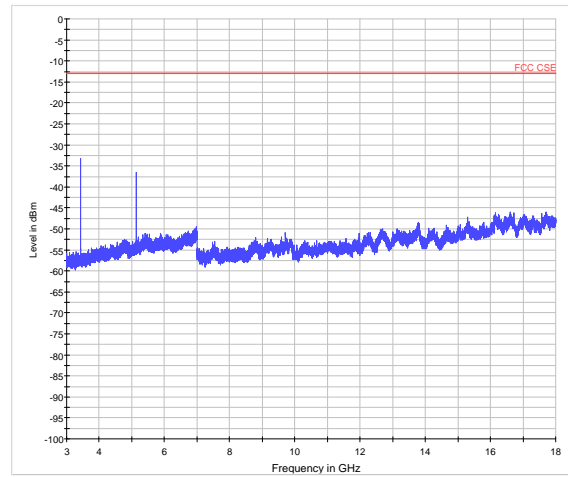

LTE Band 4 5MHz CH-High 18GHz ~26.5GHz

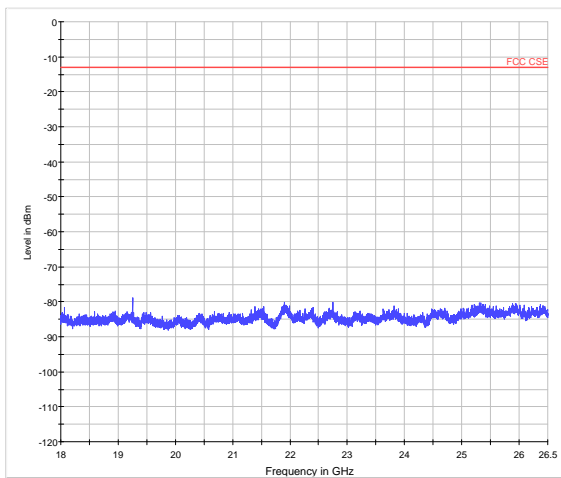

LTE Band 4 10MHz CH-Low 18GHz ~26.5GHz

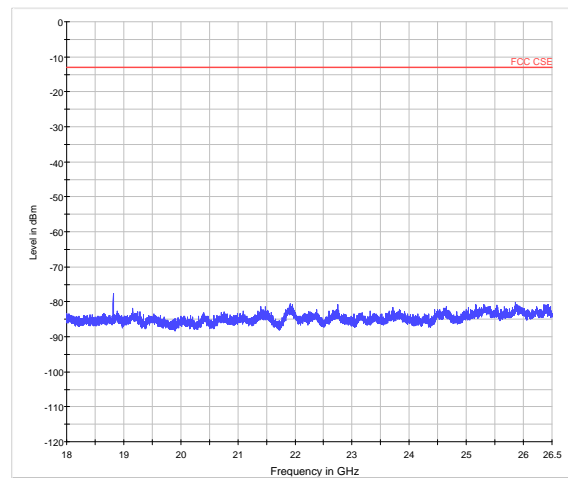



LTE Band 4 10MHz CH-Middle30MHz~3GHz

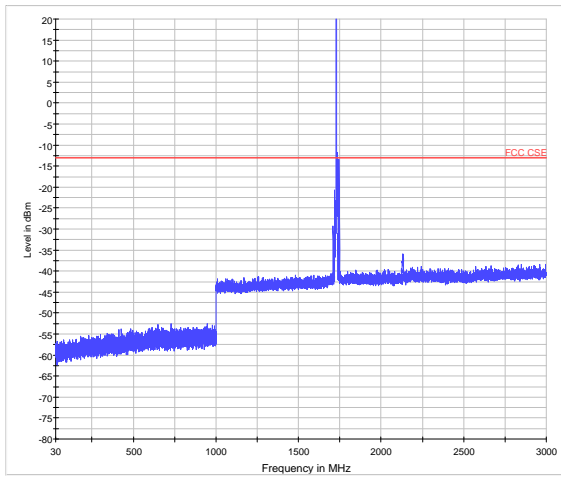

LTE Band 4 10MHz CH-High 30MHz~3GHz

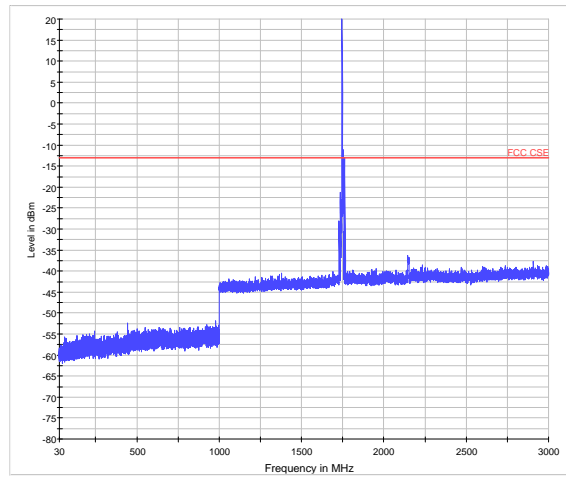

LTE Band 4 10MHz CH-Middle 3GHz~18GHz

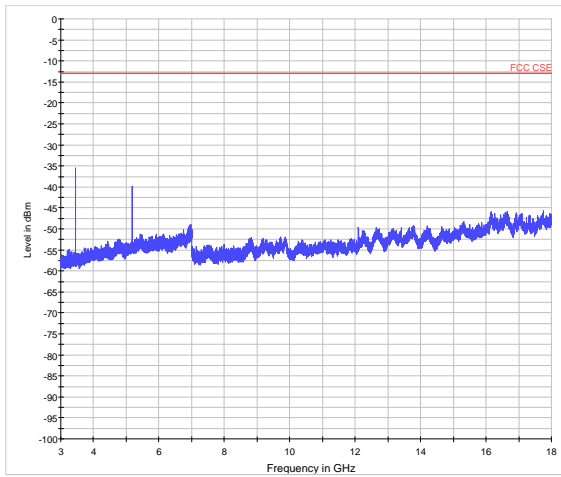

LTE Band 4 10MHz CH-High 3GHz~18GHz

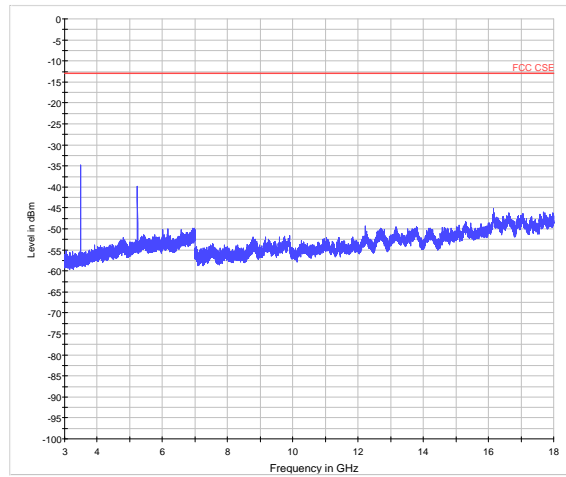

LTE Band 4 10MHz CH-Middle 18GHz~26.5GHz

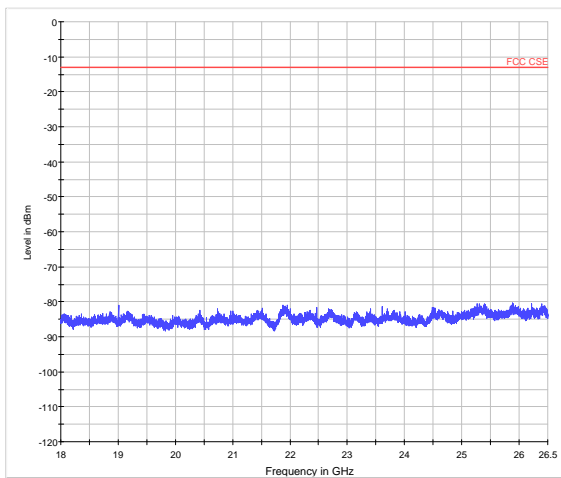

LTE Band 4 10MHz CH-High 18GHz ~26.5GHz

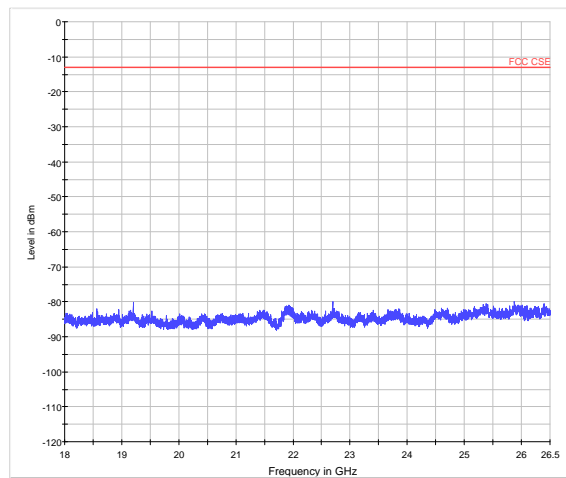



LTE Band 4 15MHz CH-Low 30MHz~3GHz

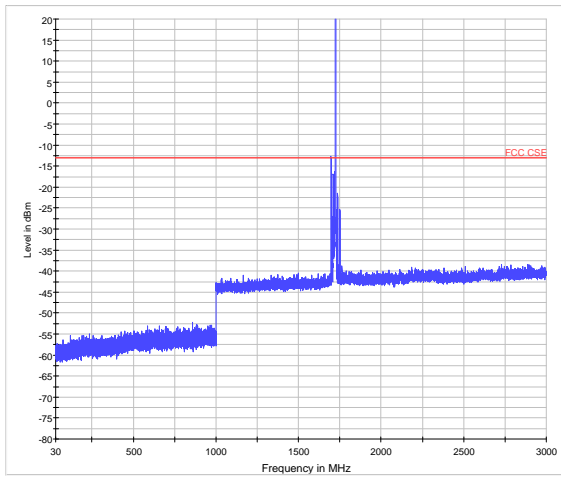

LTE Band 4 15MHz CH-Middle 30MHz~3GHz

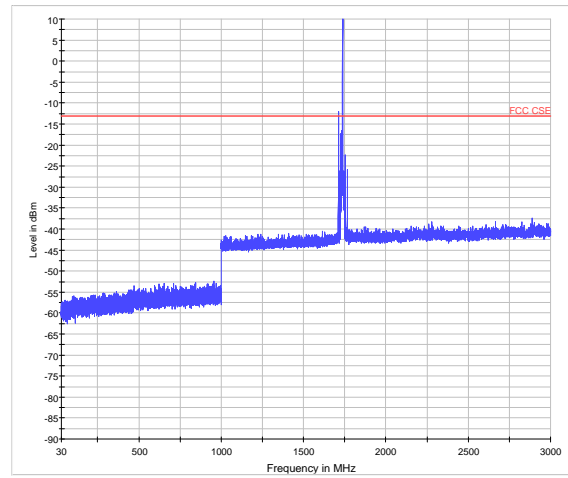

LTE Band 4 15MHz CH-Low 3GHz~18GHz

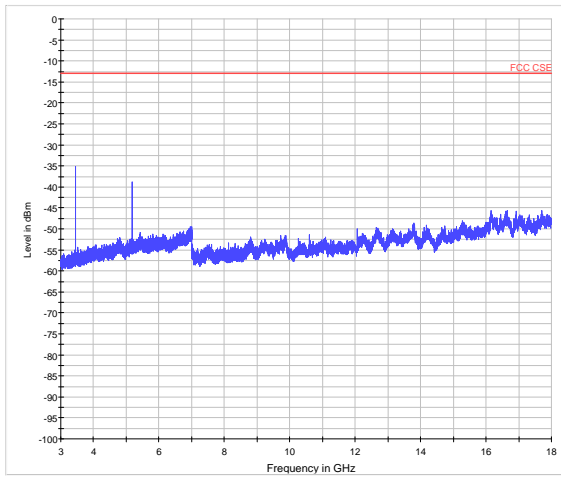

LTE Band 4 15MHz CH-Middle 3GHz~18GHz

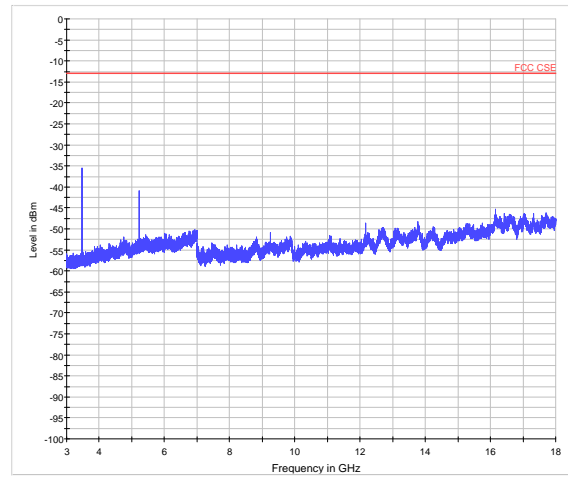

LTE Band 4 15MHz CH-Low 18GHz ~26.5GHz

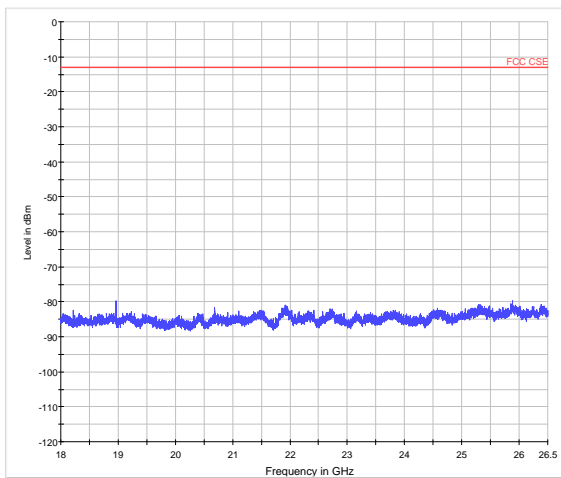

LTE Band 4 15MHz CH-Middle 18GHz~26.5GHz

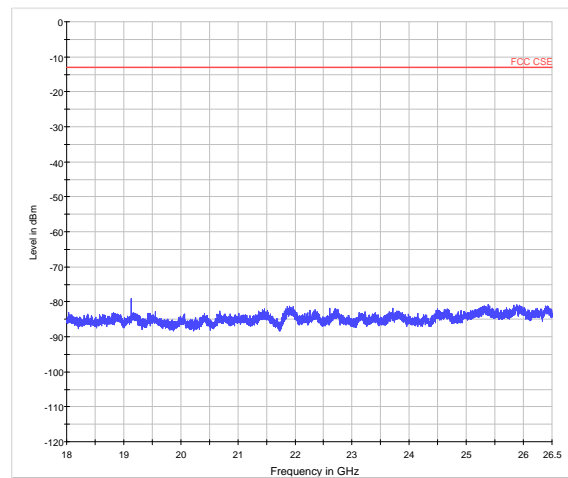



LTE Band 4 15MHz CH-High 30MHz~3GHz

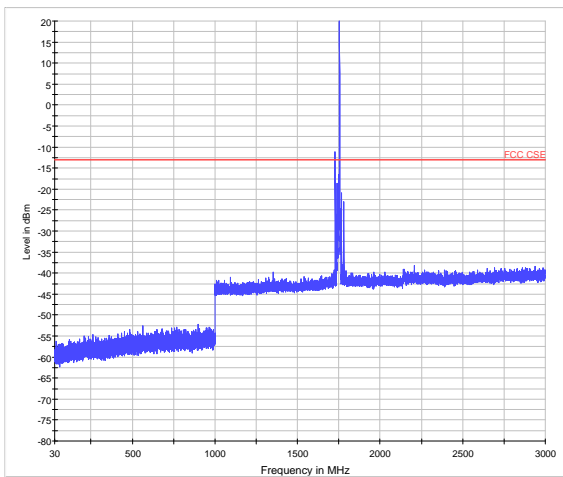

LTE Band 4 20MHz CH-Low 30MHz~3GHz

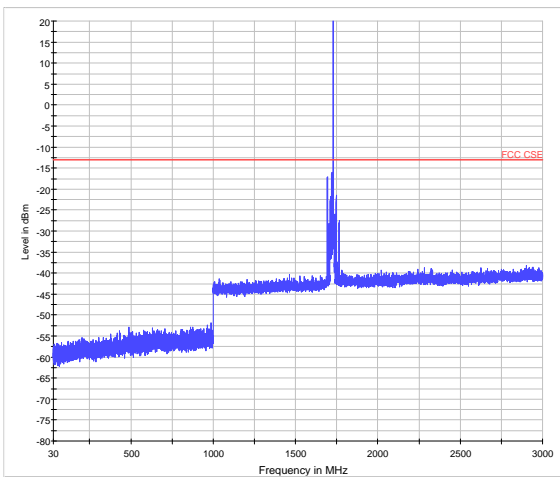

LTE Band 4 15MHz CH-High 3GHz~18GHz

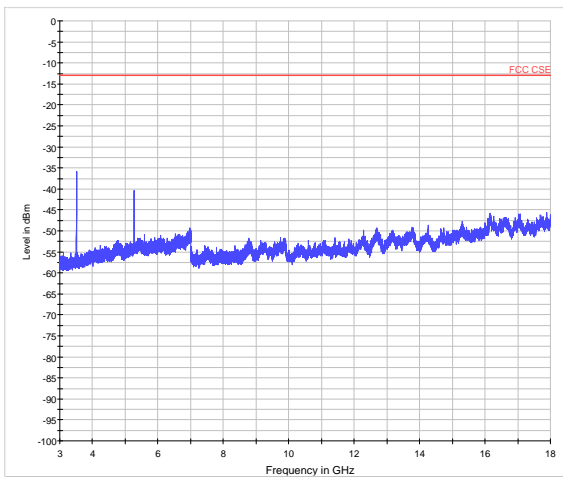

LTE Band 4 20MHz CH-Low 3GHz~18GHz

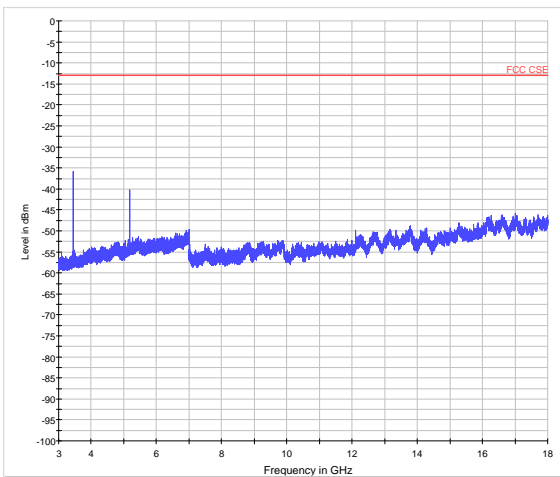

LTE Band 4 15MHz CH-High 18GHz ~26.5GHz

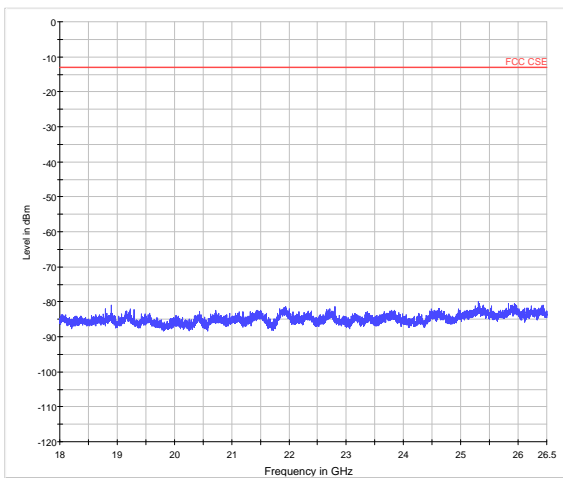

LTE Band 4 20MHz CH-Low 18GHz ~26.5GHz

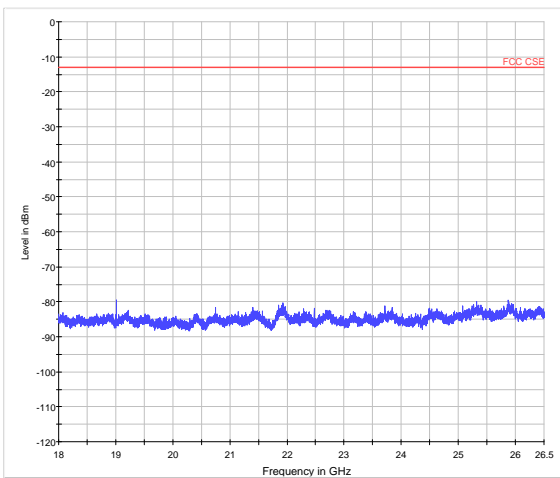



LTE Band 4 20MHz CH-Middle30MHz~3GHz

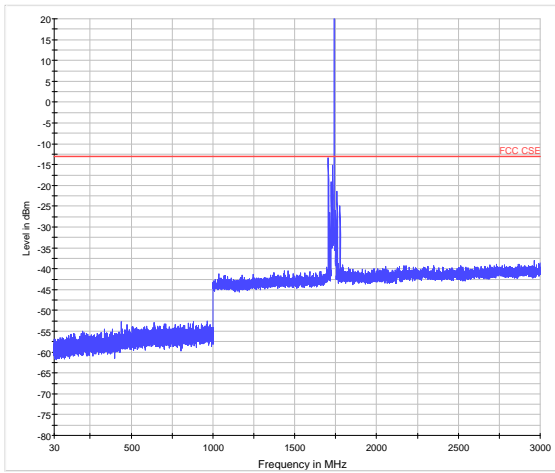

LTE Band 4 20MHz CH-High 30MHz~3GHz

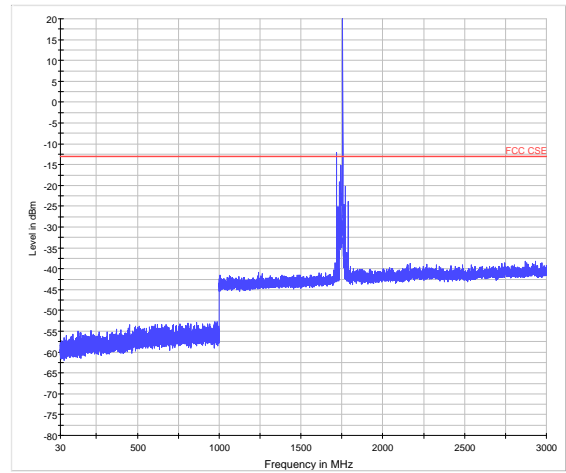

LTE Band 4 20MHz CH-Middle 3GHz~18GHz

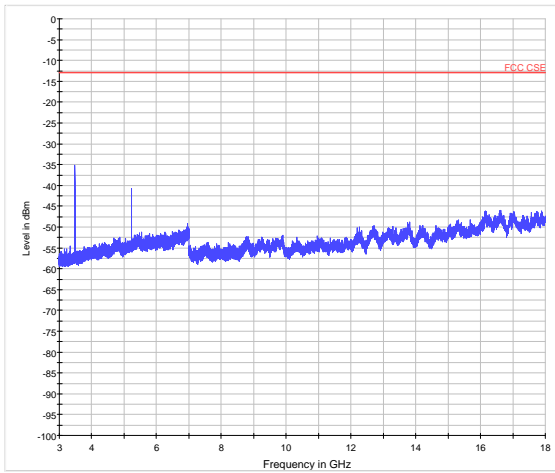

LTE Band 4 20MHz CH-High 3GHz~18GHz

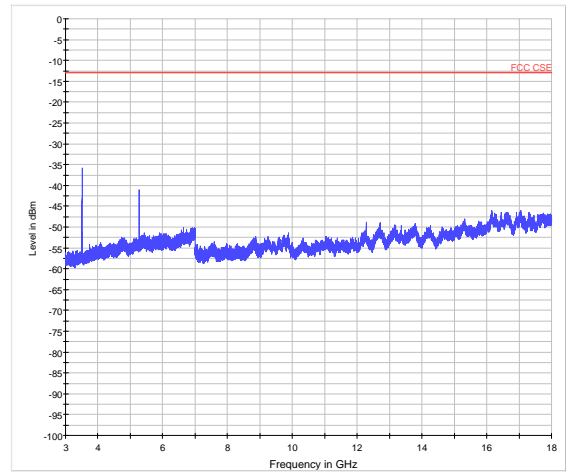

LTE Band 4 20MHz CH-Middle 18GHz~26.5GHz

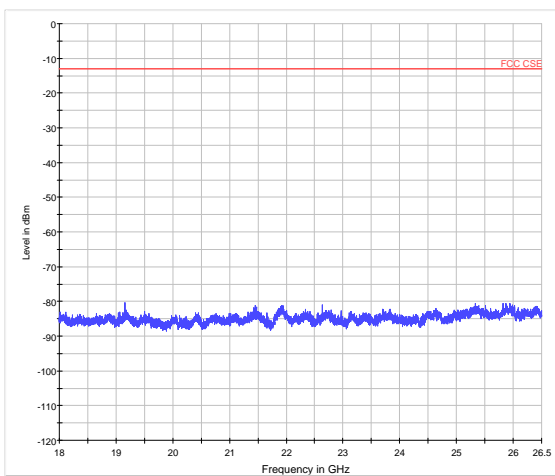

LTE Band 4 20MHz CH-High 18GHz ~26.5GHz

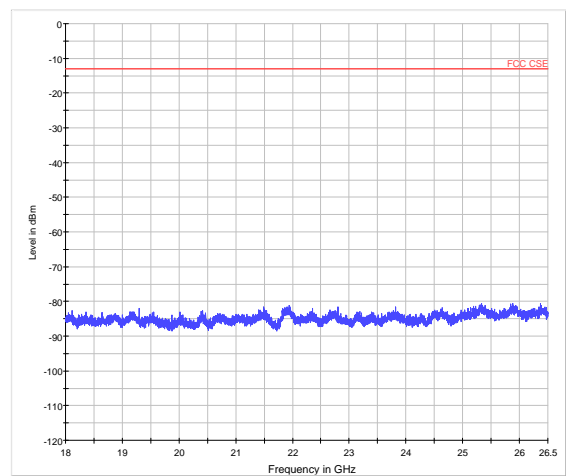



LTE Band 7 5MHz CH-Low 30MHz~3GHz

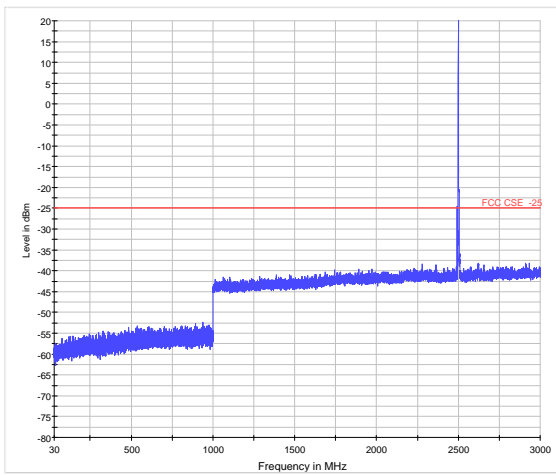

LTE Band 7 5MHz CH-Middle 30MHz~3GHz

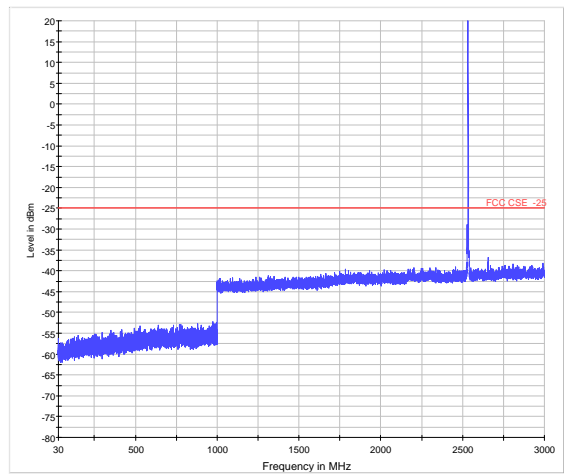

LTE Band 7 5MHz CH-Low 3GHz~18GHz

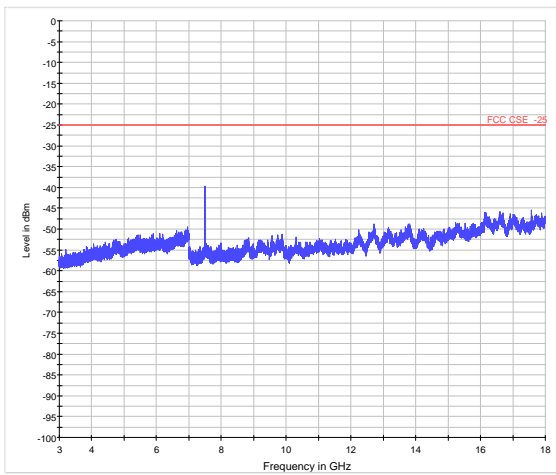

LTE Band 7 5MHz CH-Middle 3GHz~18GHz

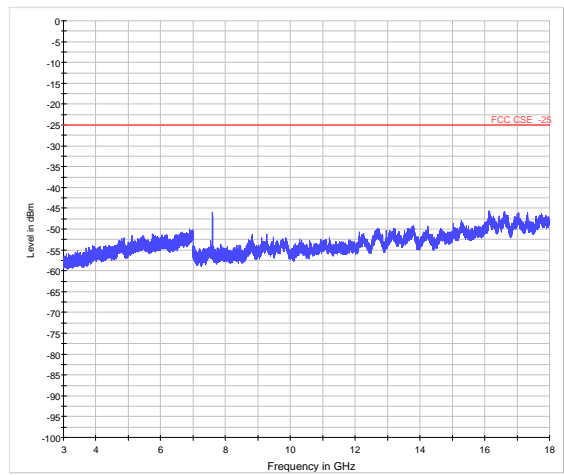

LTE Band 7 5MHz CH-Low 18GHz~26.5GHz

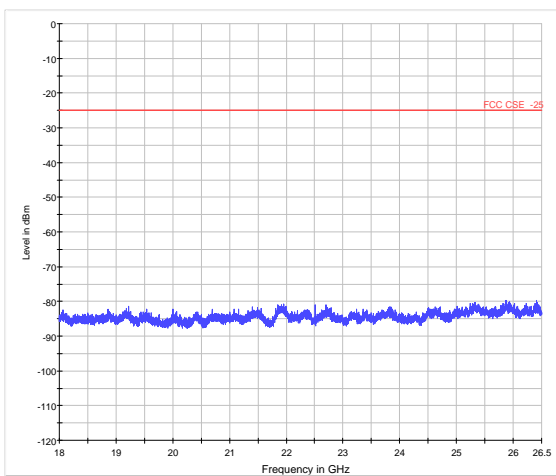

LTE Band 7 5MHz CH-Middle 18GHz~26.5GHz

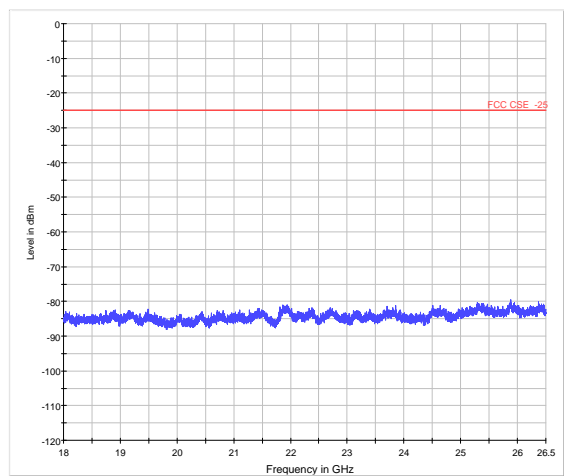



LTE Band 7 5MHz CH-High 30MHz~3GHz

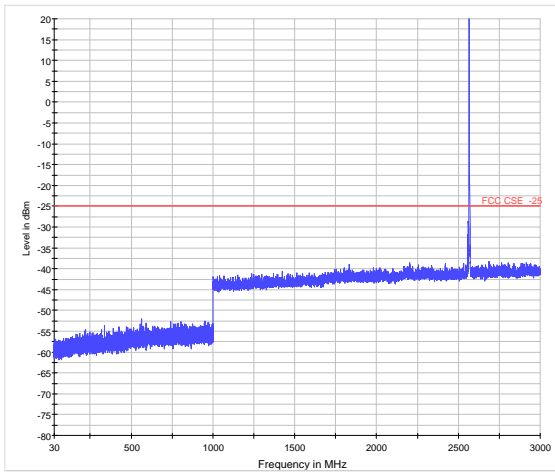

LTE Band 7 10MHz CH-Low 30MHz~3GHz

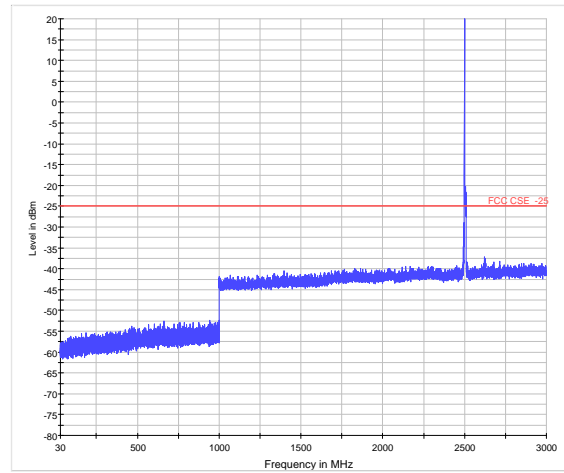

LTE Band 7 5MHz CH-High 3GHz~18GHz

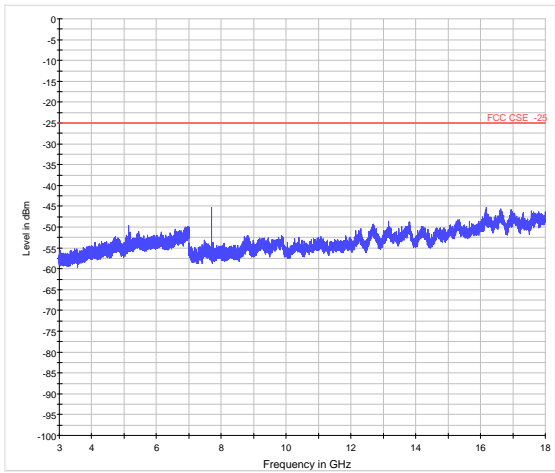

LTE Band 7 10MHz CH-Low 3GHz~18GHz

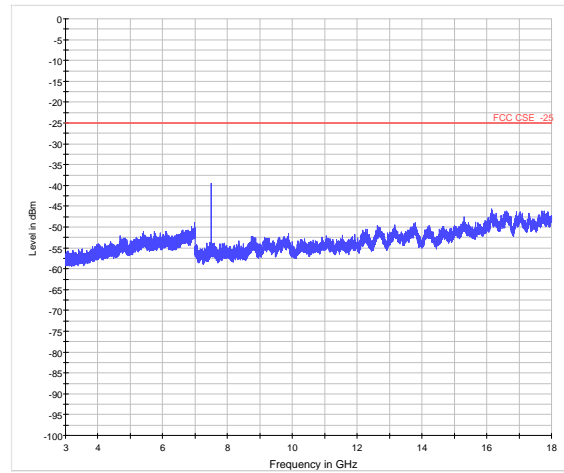

LTE Band 7 5MHz CH-High 18GHz~26.5GHz

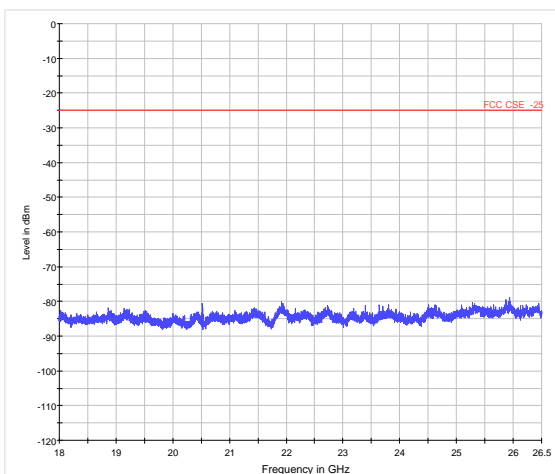

LTE Band 7 10MHz C CH-Low 18GHz~26.5GHz

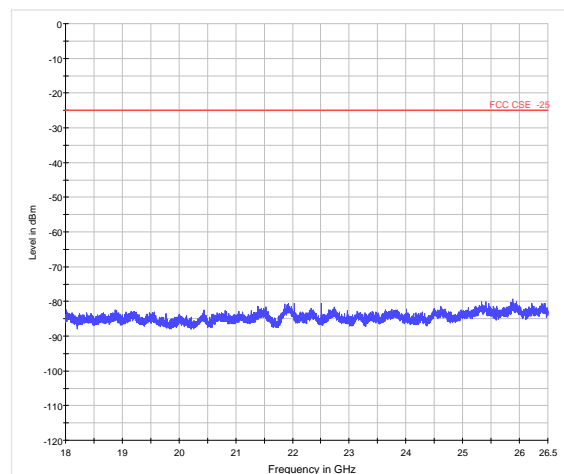



LTE Band 7 10MHz CH-Middle 30MHz~3GHz

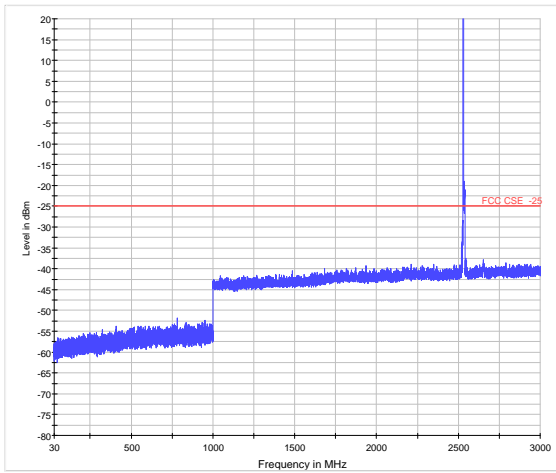

LTE Band 7 10MHz CH-High 30MHz~3GHz

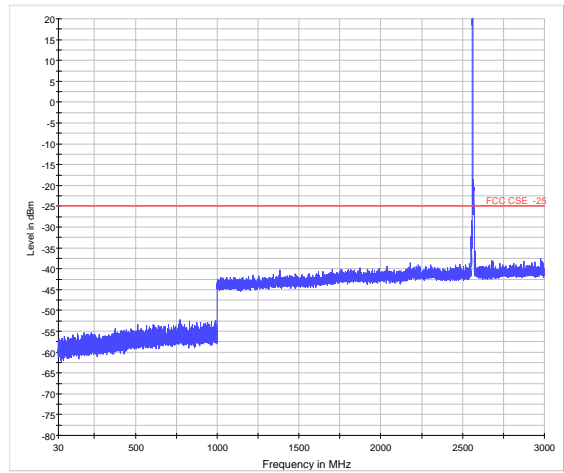

LTE Band 7 10MHz CH-Middle 3GHz~18GHz

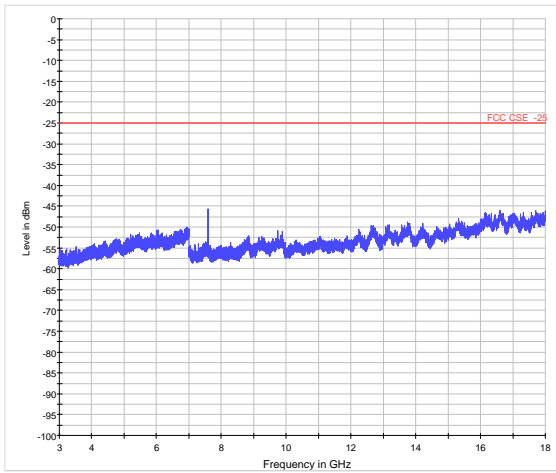

LTE Band 7 10MHz CH-High 3GHz~18GHz

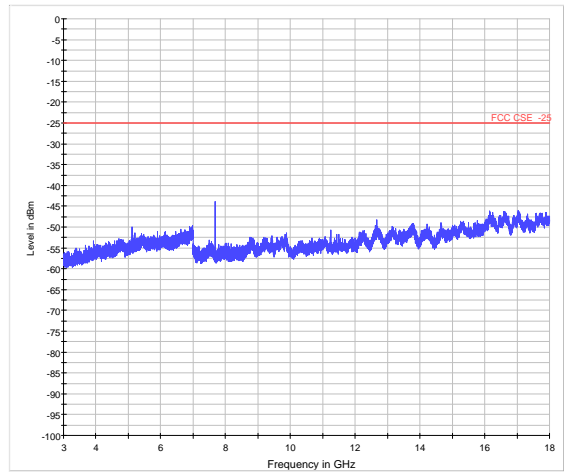

LTE Band 7 10MHz CH-Middle 18GHz~26.5GHz

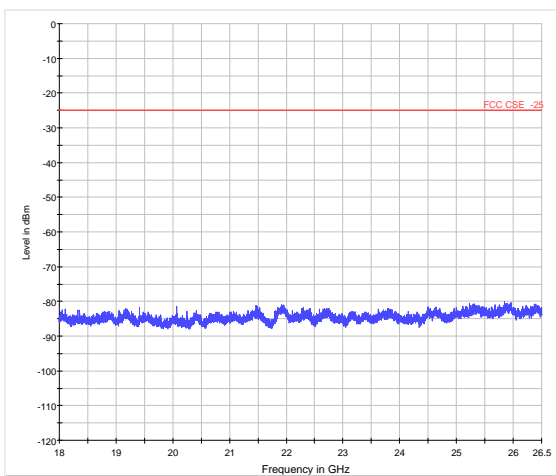

LTE Band 7 10MHz CH-High 18GHz~26.5GHz

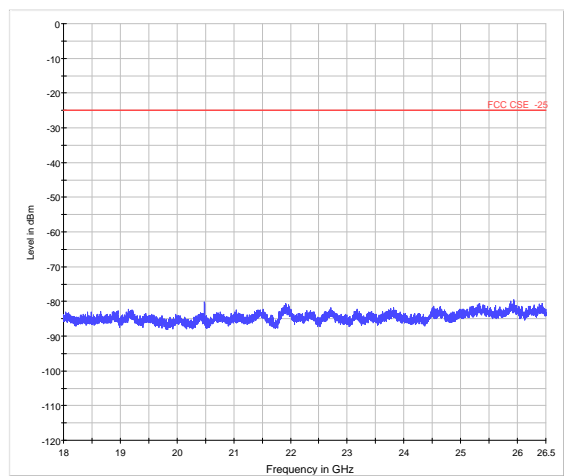



LTE Band 7 15MHz CH-Low 30MHz~3GHz

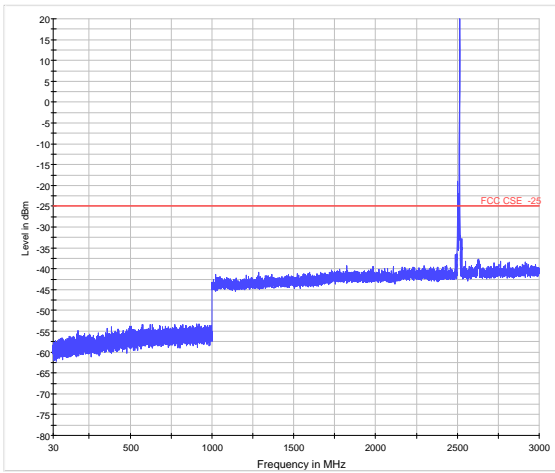

LTE Band 7 15MHz CH-Middle 30MHz~3GHz

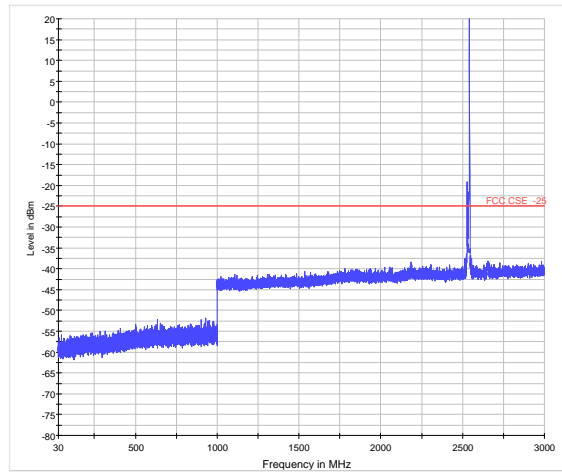

LTE Band 7 15MHz CH-Low 3GHz~18GHz

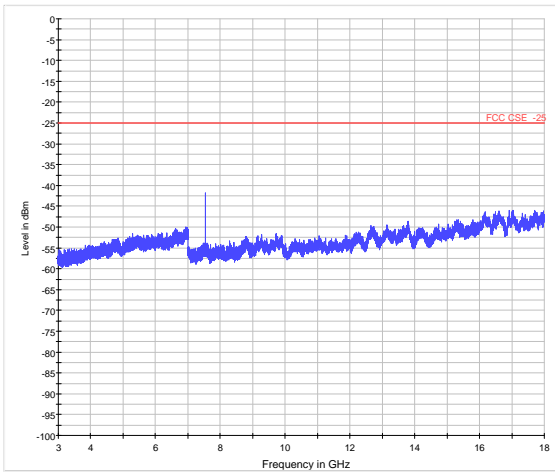

LTE Band 7 15MHz CH-Middle 3GHz~18GHz

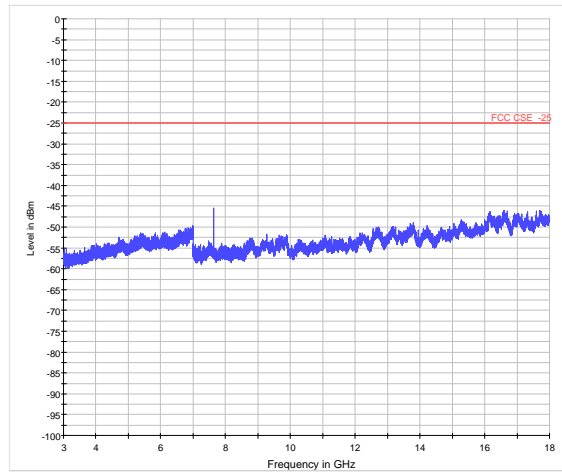

LTE Band 7 15MHz CH-Low 18GHz~26.5GHz

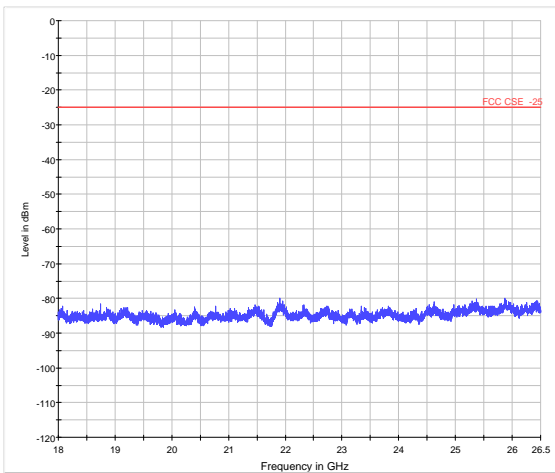

LTE Band 7 15MHz CH-Middle 18GHz~26.5GHz

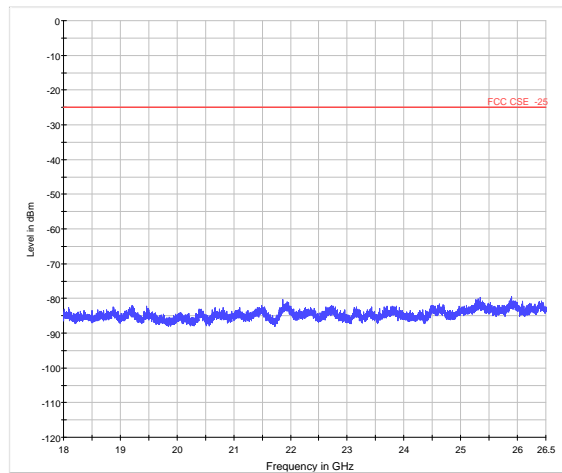



LTE Band 7 15MHz CH-High 30MHz~3GHz

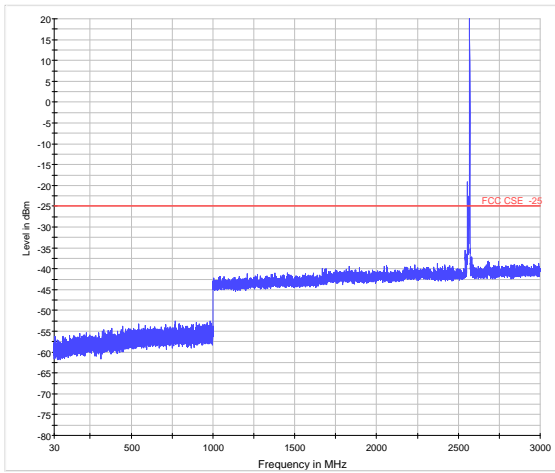

LTE Band 7 20MHz CH-Low 30MHz~3GHz

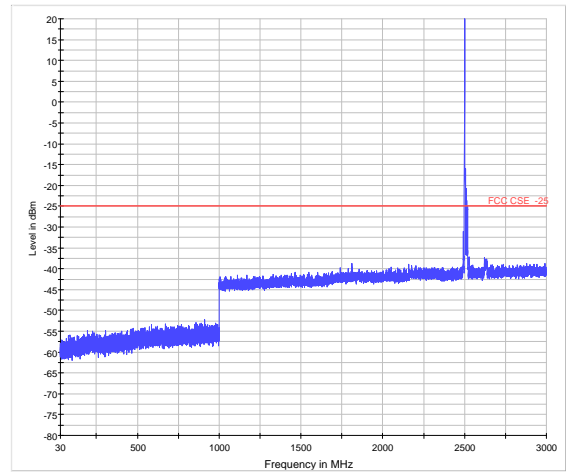

LTE Band 7 15MHz CH-High 3GHz~18GHz

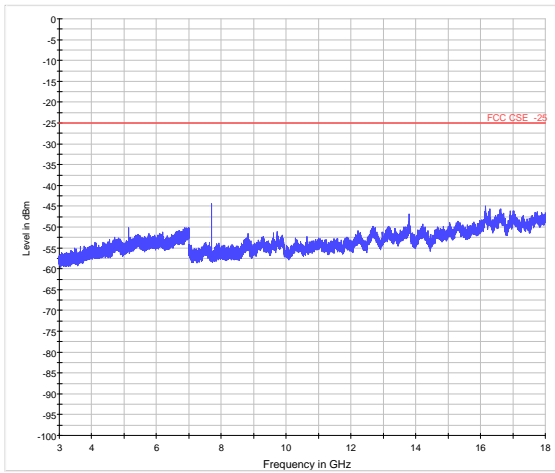

LTE Band 7 20MHz CH-Low 3GHz~18GHz

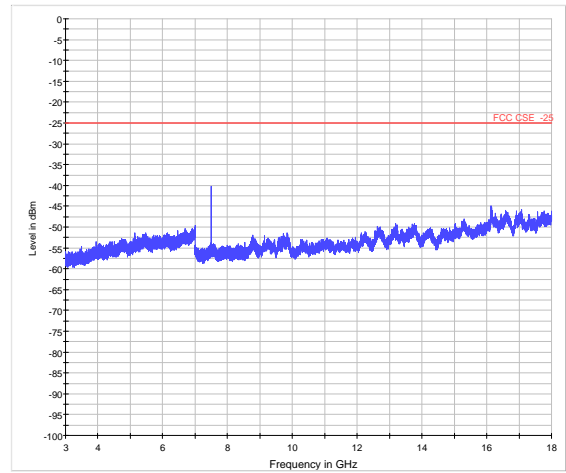

LTE Band 7 15MHz CH-High 18GHz~26.5GHz

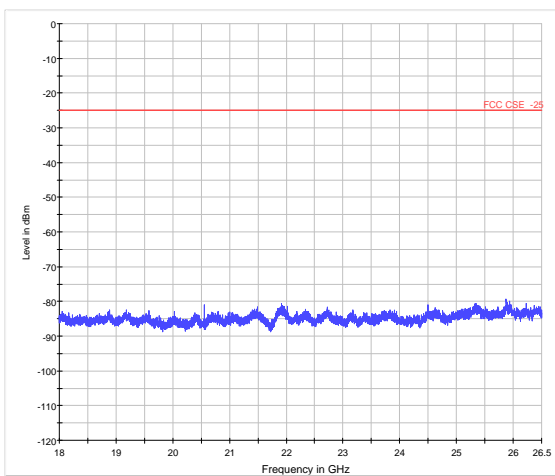

LTE Band 7 20MHz CH-Low 18GHz~26.5GHz

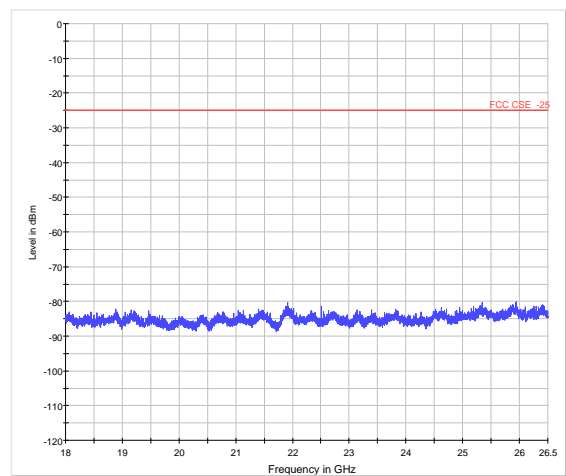



LTE Band 7 20MHz CH-Middle 30MHz~3GHz

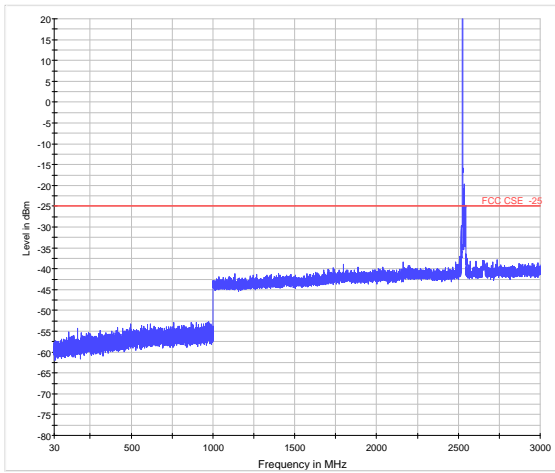

LTE Band 7 20MHz CH-High 30MHz~3GHz

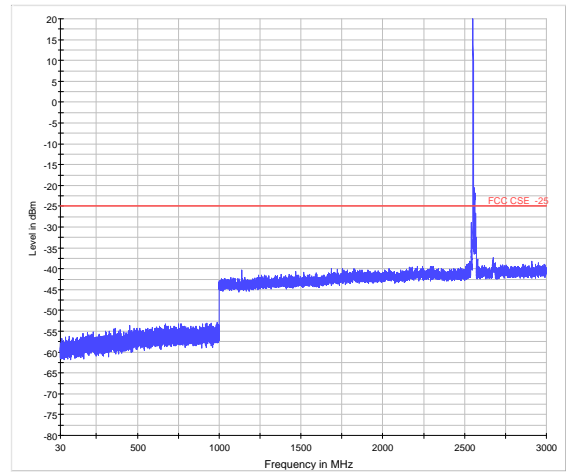

LTE Band 7 20MHz CH-Middle 3GHz~18GHz

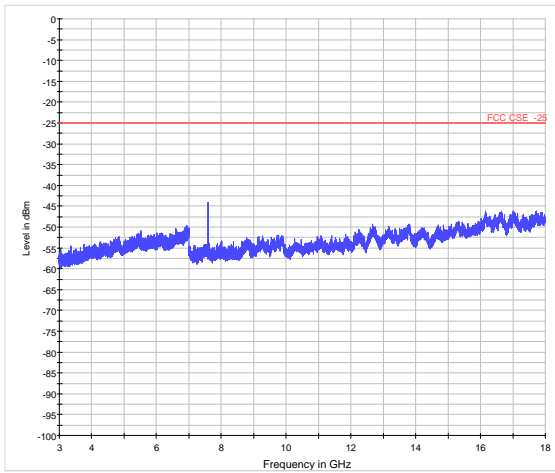

LTE Band 7 20MHz CH-High 3GHz~18GHz

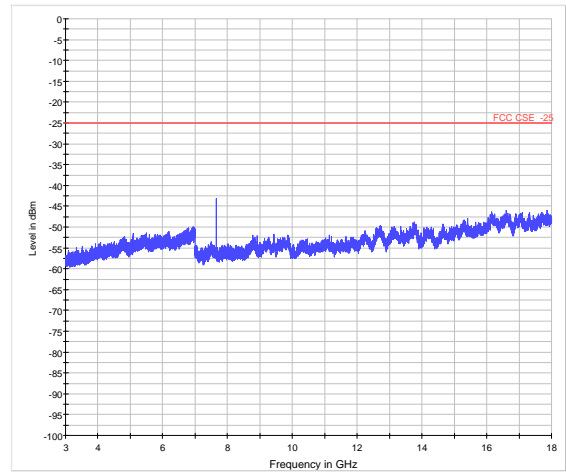

LTE Band 7 20MHz CH-Middle 18GHz~26.5GHz

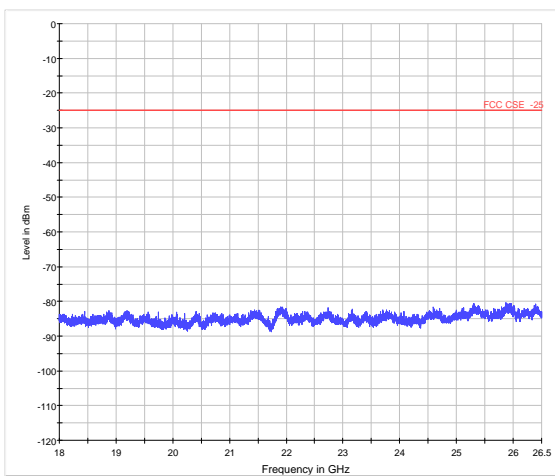

LTE Band 7 20MHz CH-High 18GHz~26.5GHz

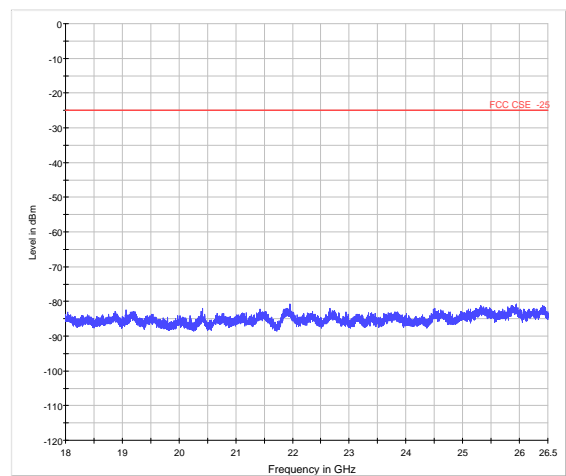



LTE Band 12 1.4MHz CH-Low 30MHz~1GHz

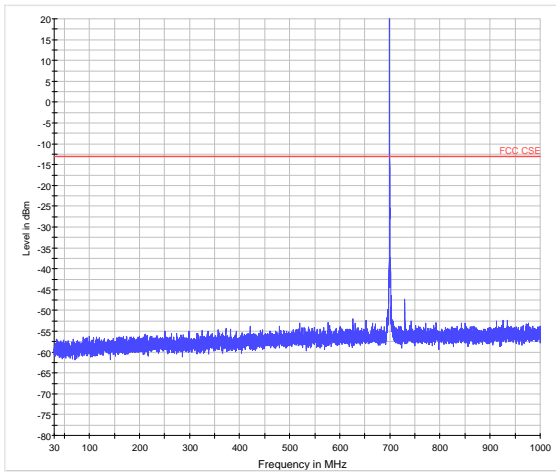

LTE Band 12 1.4MHz CH-Middle 30MHz~1GHz

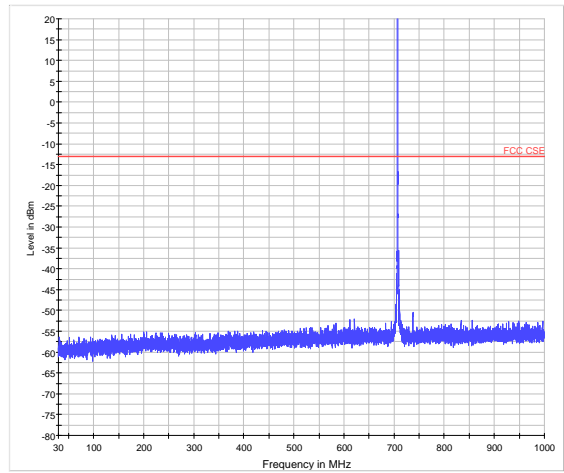

LTE Band 12 1.4MHz CH-Low 1GHz~3GHz

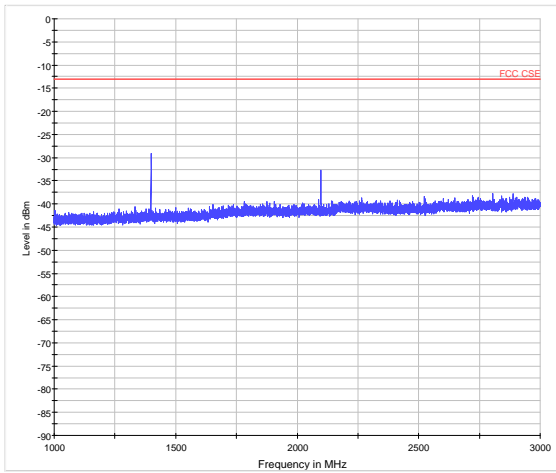

LTE Band 12 1.4MHz CH-Middle 1GHz~3GHz

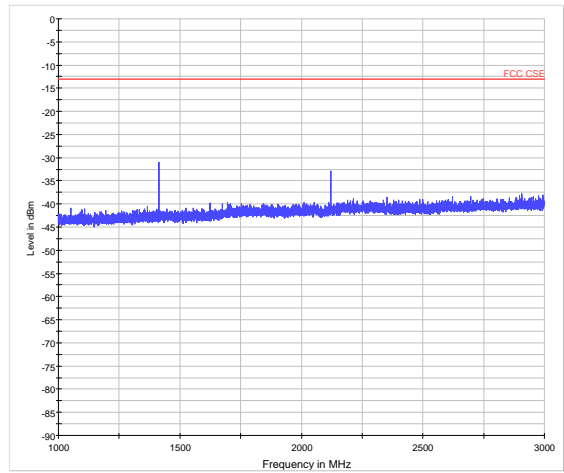

LTE Band 12 1.4MHz CH-Low 3GHz~8GHz

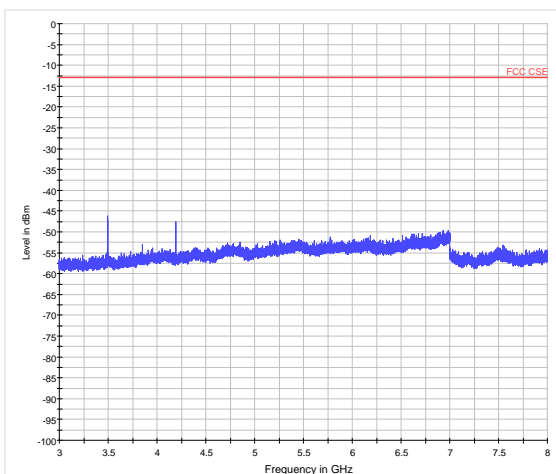

LTE Band 12 1.4MHz CH-Middle 3GHz~8GHz

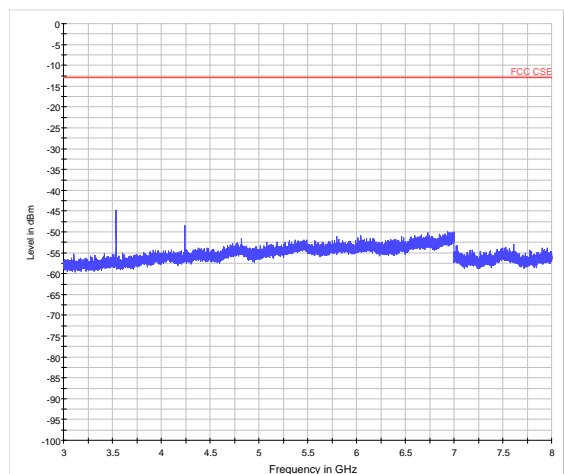



LTE Band 12 1.4MHz CH-High 30MHz~1GHz

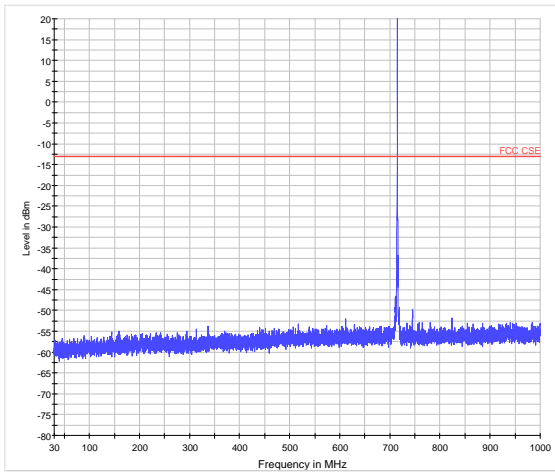

LTE Band 12 3MHz CH-Low 30MHz~1GHz

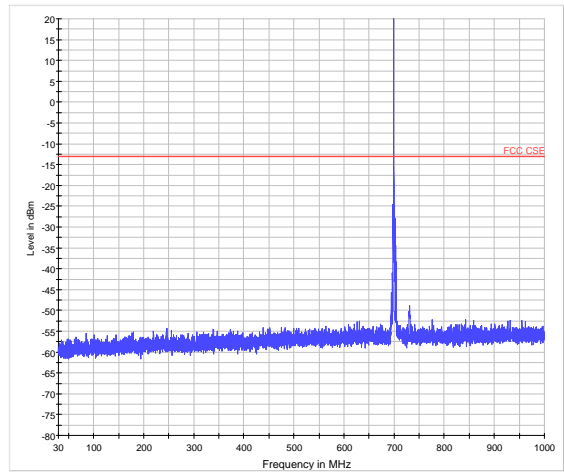

LTE Band 12 1.4MHz CH-High 1GHz~3GHz

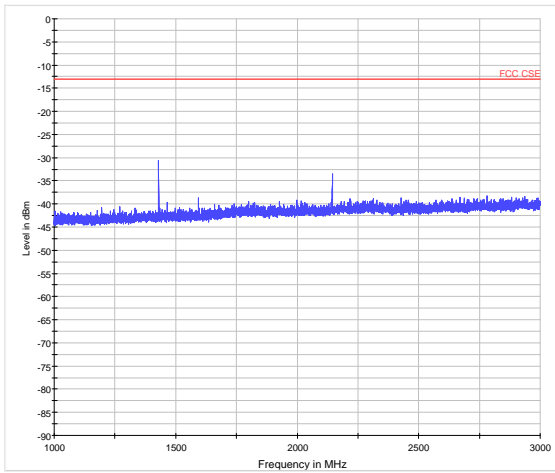

LTE Band 12 3MHz CH-Low 1GHz~3GHz

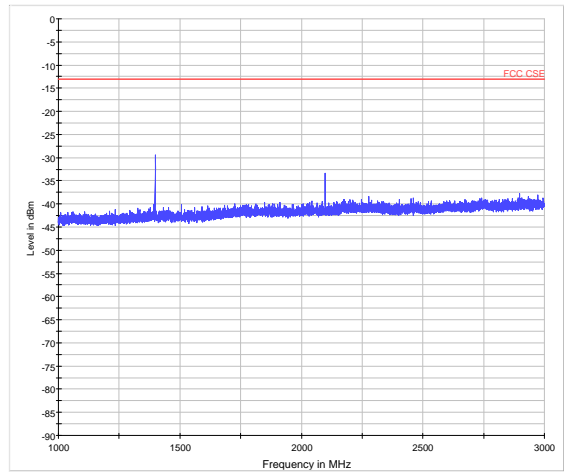

LTE Band 12 1.4MHz CH-High 3GHz~8GHz

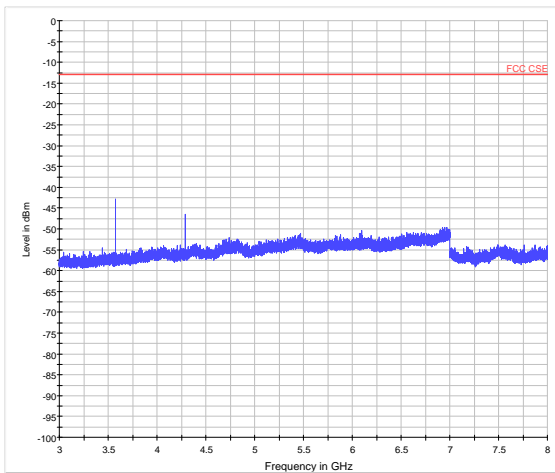

LTE Band 12 3MHz CH-Low 3GHz~8GHz

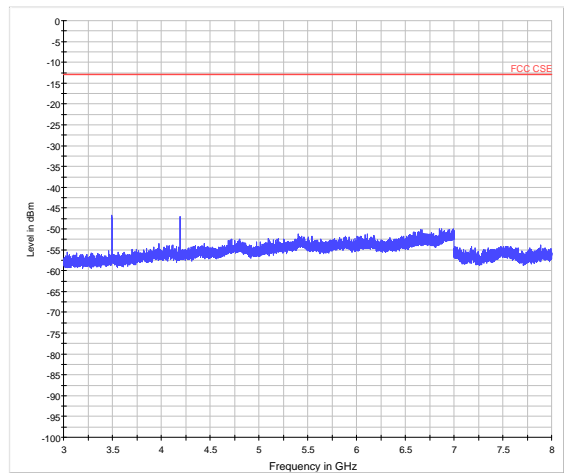



LTE Band 12 3MHz CH-Middle 30MHz~1GHz

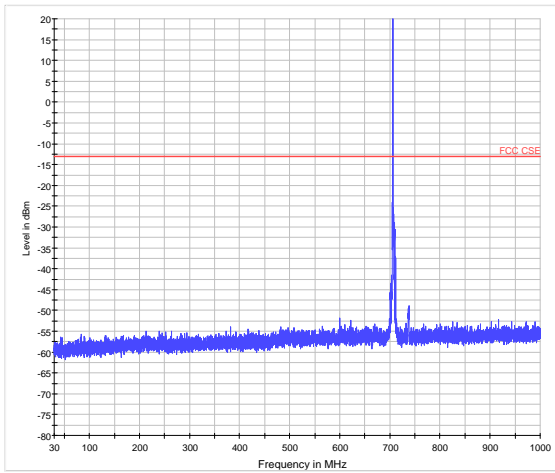

LTE Band 12 3MHz CH-High 30MHz~1GHz

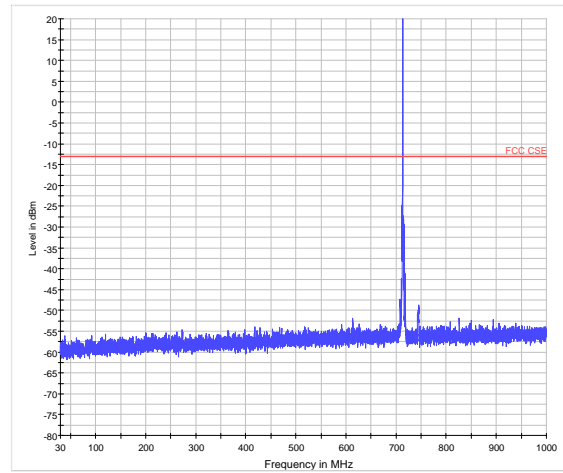

LTE Band 12 3MHz CH-Middle 1GHz~3GHz

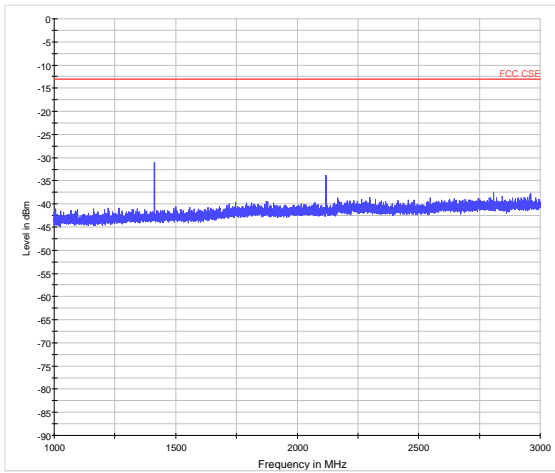

LTE Band 12 3MHz CH-High 1GHz~3GHz

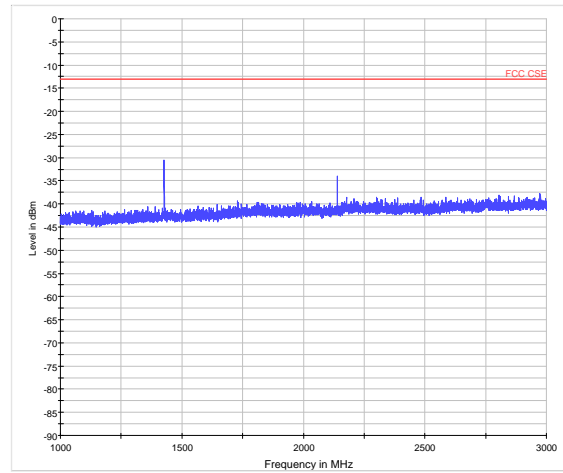

LTE Band 12 3MHz CH-Middle 3GHz~8GHz

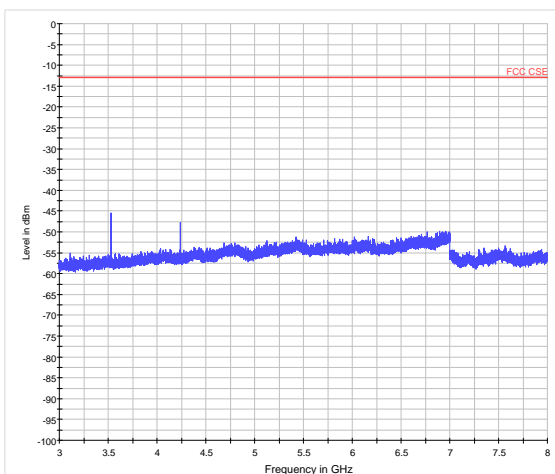

LTE Band 12 3MHz CH-High 3GHz~8GHz

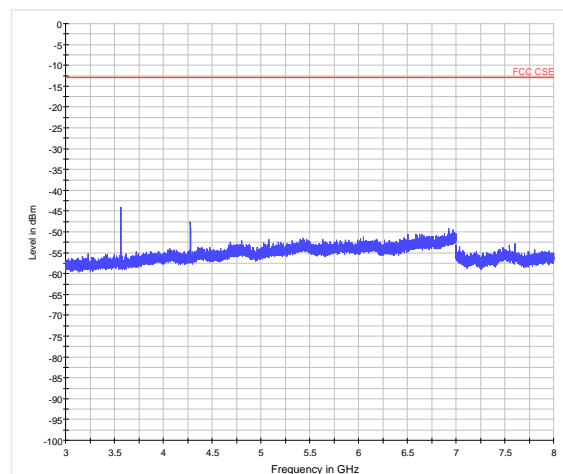



LTE Band 12 5MHz CH-Low 30MHz~1GHz

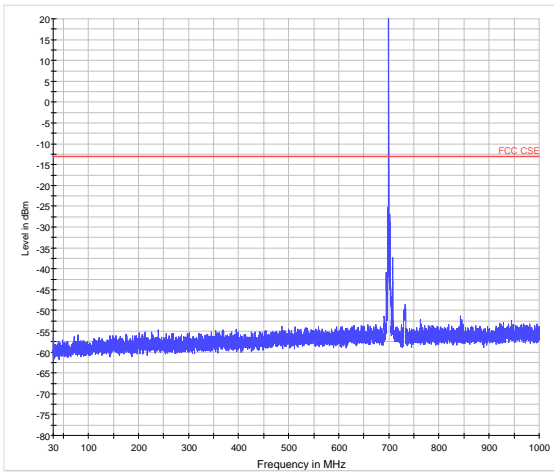

LTE Band 12 5MHz CH-Middle 30MHz~1GHz

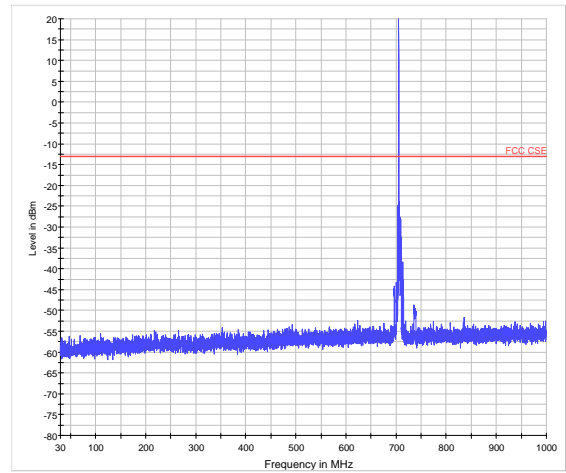

LTE Band 12 5MHz CH-Low 1GHz~3GHz

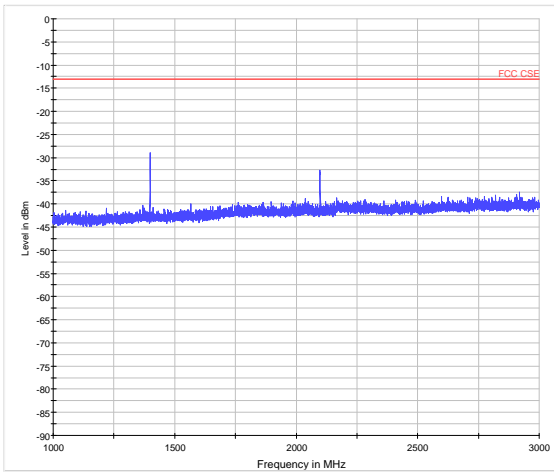

LTE Band 12 5MHz CH-Middle 1GHz~3GHz

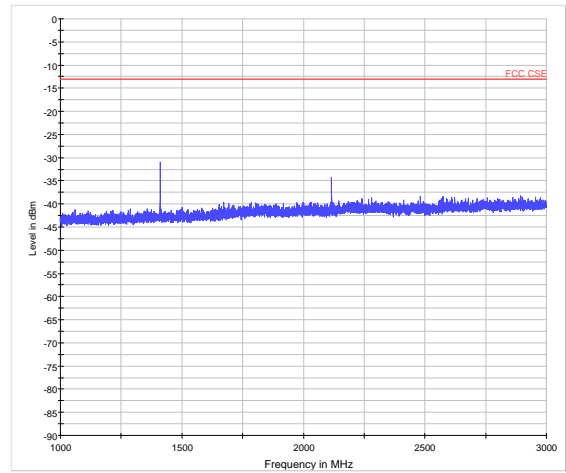

LTE Band 12 5MHz CH-Low 3GHz~8GHz

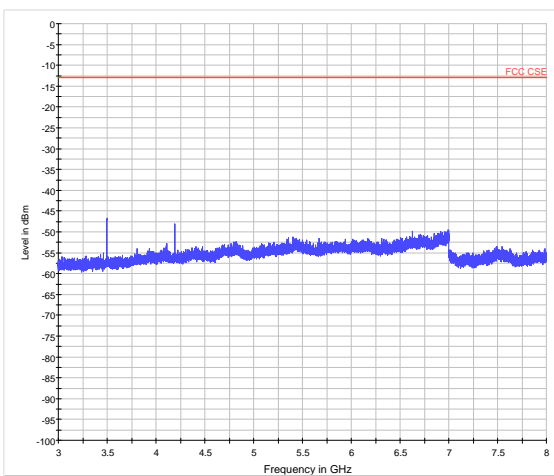

LTE Band 12 5MHz CH-Middle 3GHz~8GHz

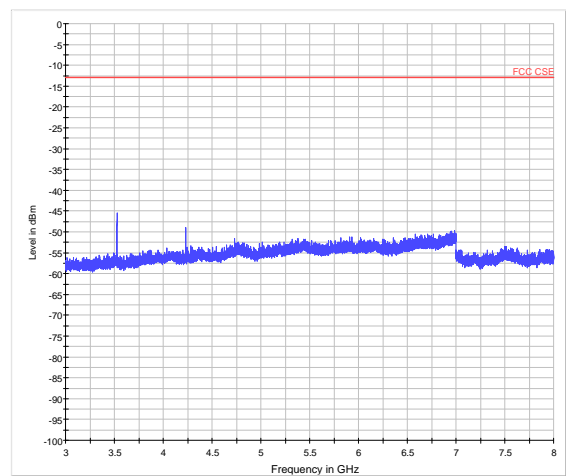



LTE Band 12 5MHz CH-High 30MHz~1GHz

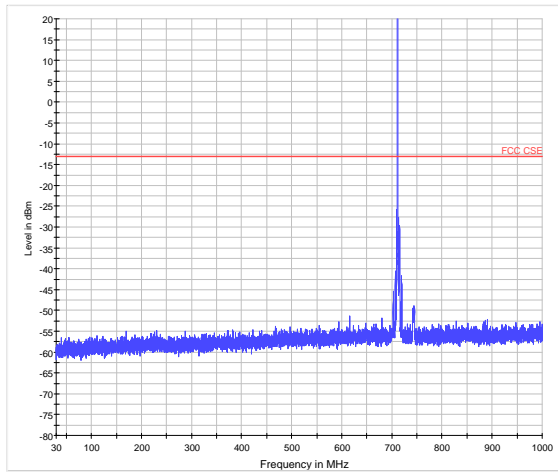

LTE Band 12 10MHz CH-Low 30MHz~1GHz

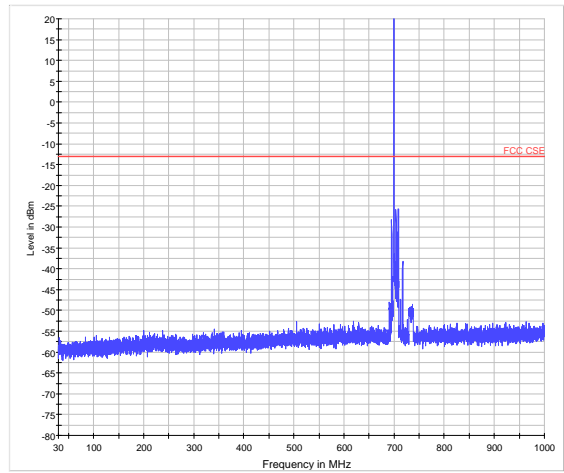

LTE Band 12 5MHz CH-High 1GHz~3GHz

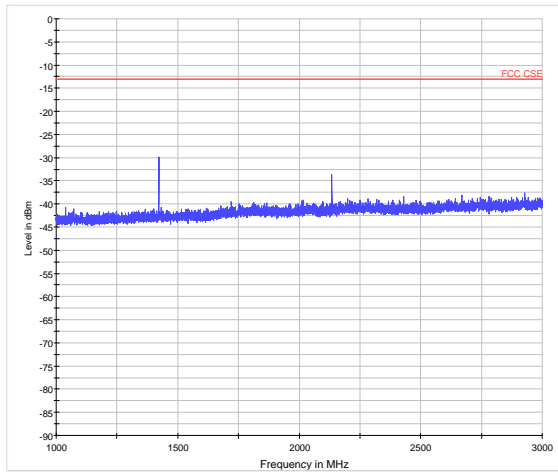

LTE Band 12 10MHz CH-Low 1GHz~3GHz

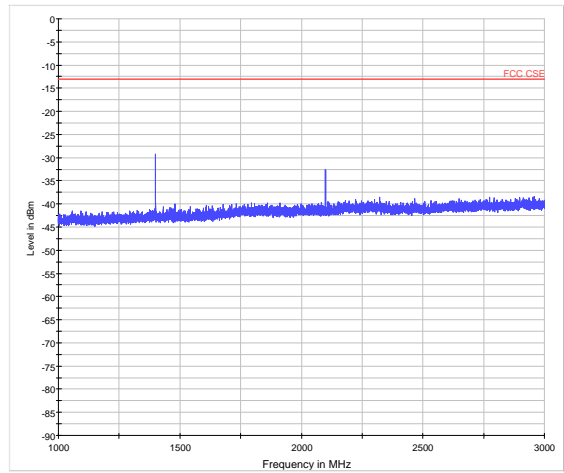

LTE Band 12 5MHz CH-High 3GHz~8GHz

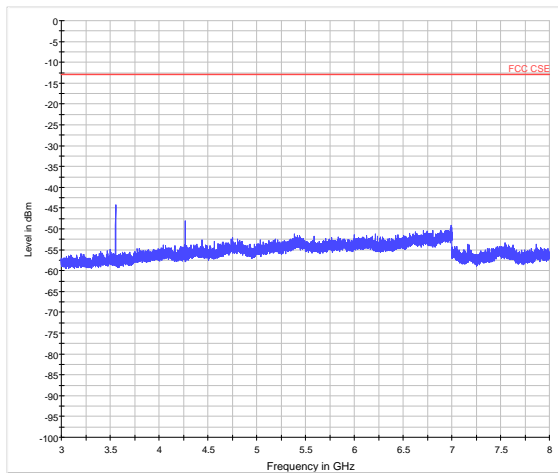

LTE Band 12 10MHz CH-Low 3GHz~8GHz

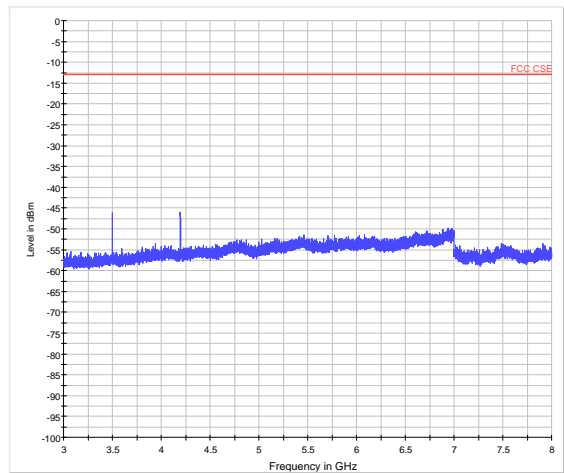



LTE Band 12 10MHz CH-Middle 30MHz~1GHz

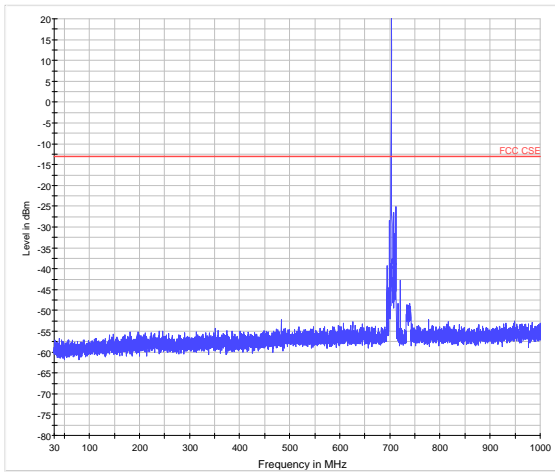

LTE Band 12 10MHz CH-High 30MHz~1GHz

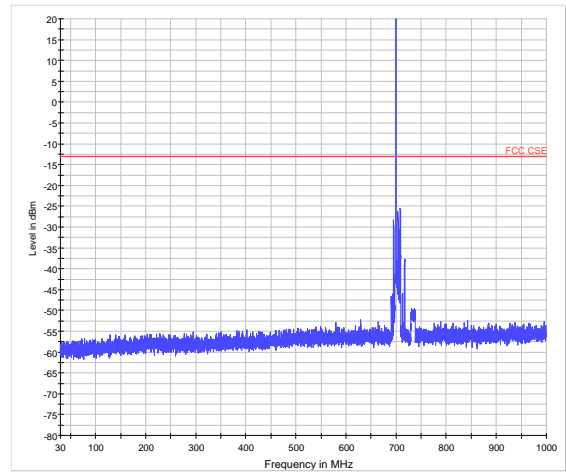

LTE Band 12 10MHz CH-Middle 1GHz~3GHz

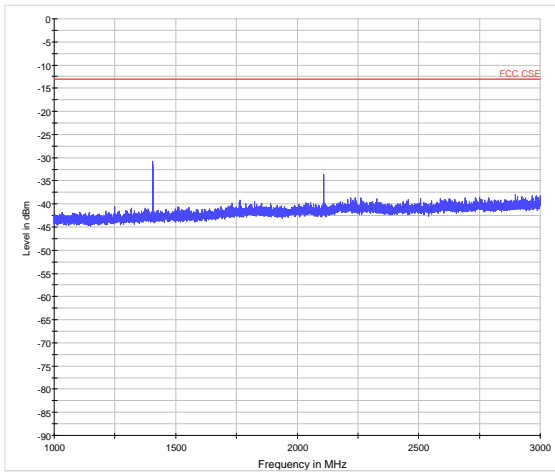

LTE Band 12 10MHz CH-High 1GHz~3GHz

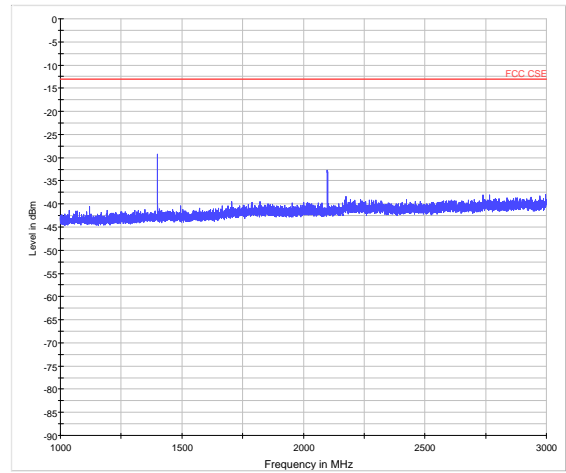

LTE Band 12 10MHz CH-Middle 3GHz~8GHz

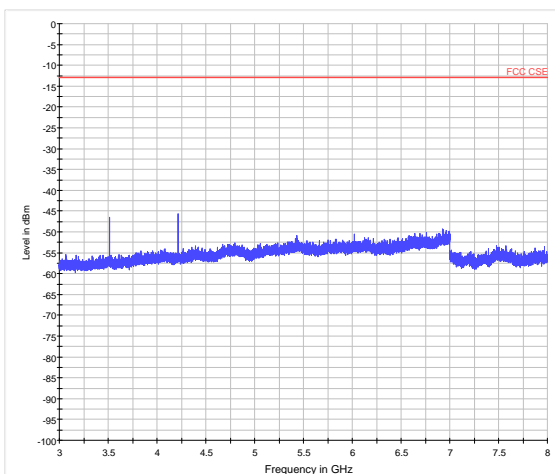

LTE Band 12 10MHz CH-High 3GHz~8GHz

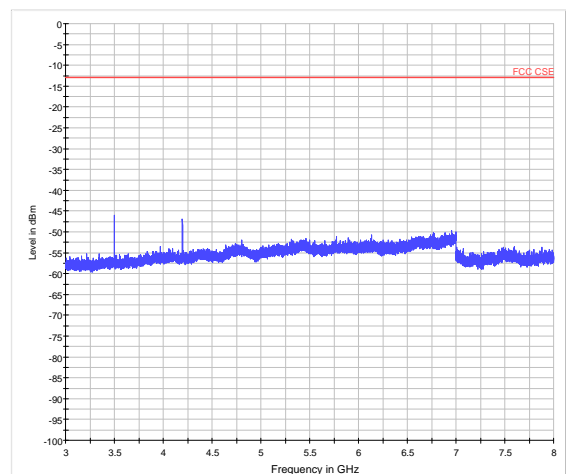



LTE Band 66 1.4MHz CH-Low 30MHz~3GHz

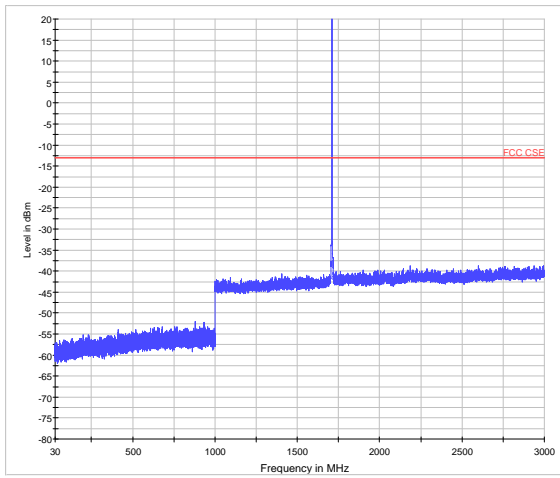

LTE Band 66 1.4MHz CH-Low 3GHz~18GHz

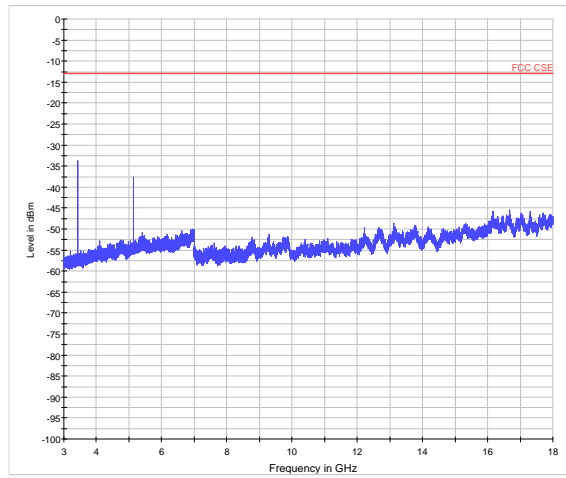

LTE Band 66 1.4MHz CH-Middle 30MHz~3GHz

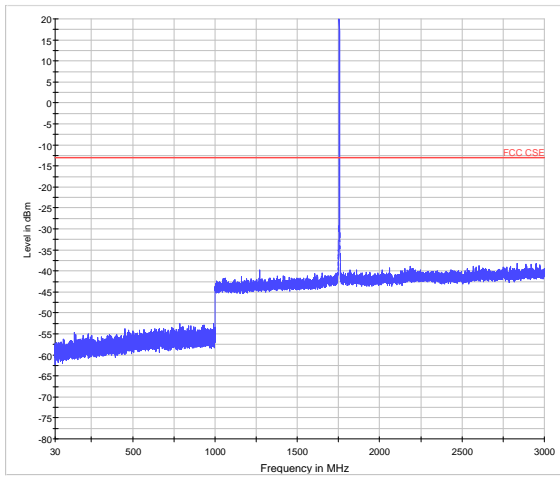

LTE Band 66 1.4MHz CH-Middle 3GHz~18GHz

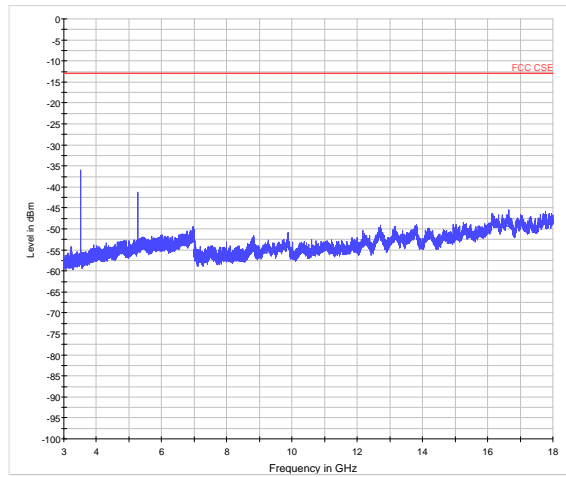

LTE Band 66 1.4MHz CH-High 30MHz~3GHz

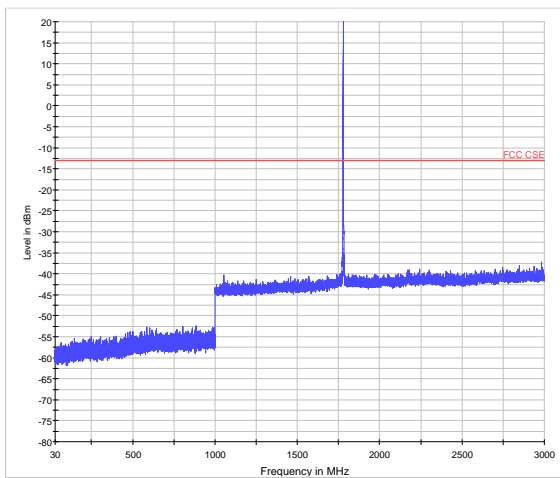

LTE Band 66 1.4MHz CH-High 3GHz~18GHz

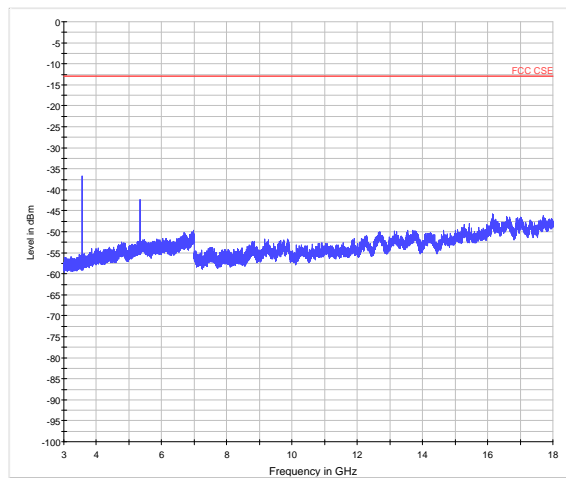



LTE Band 66 3MHz CH-Low 30MHz~3GHz

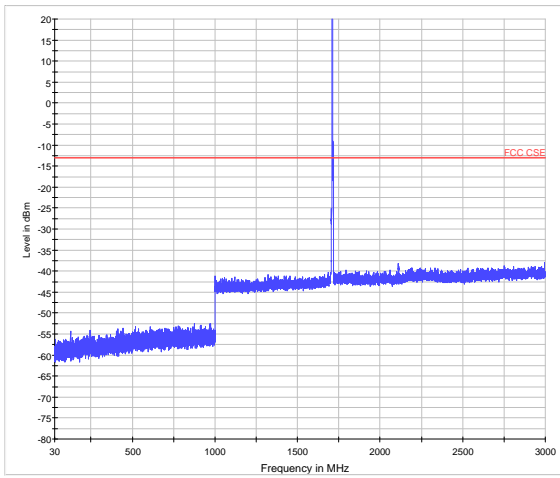

LTE Band 66 3MHz CH-Low 3GHz~18GHz

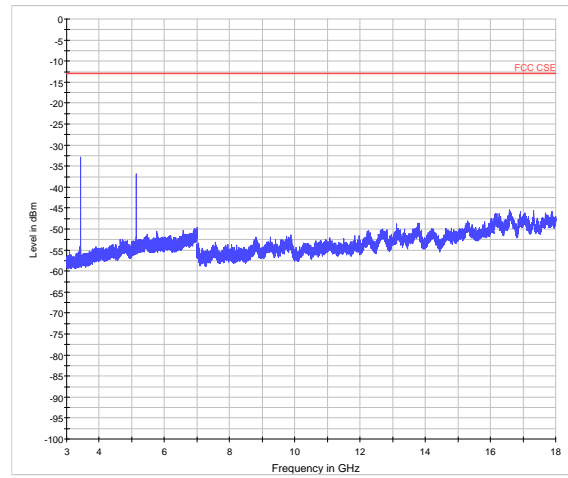

LTE Band 66 3MHz CH-Middle 30MHz~3GHz

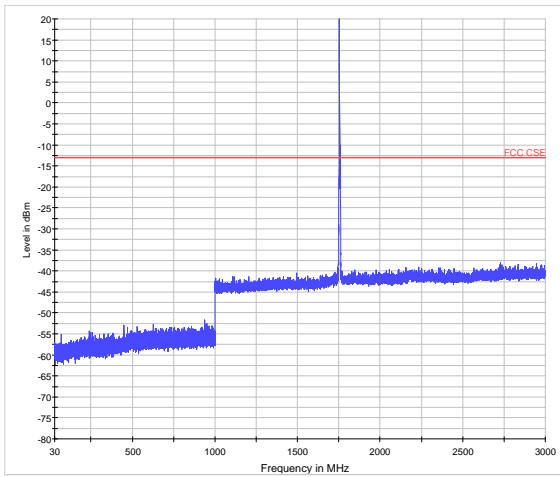

LTE Band 66 3MHz CH-Middle 3GHz~18GHz

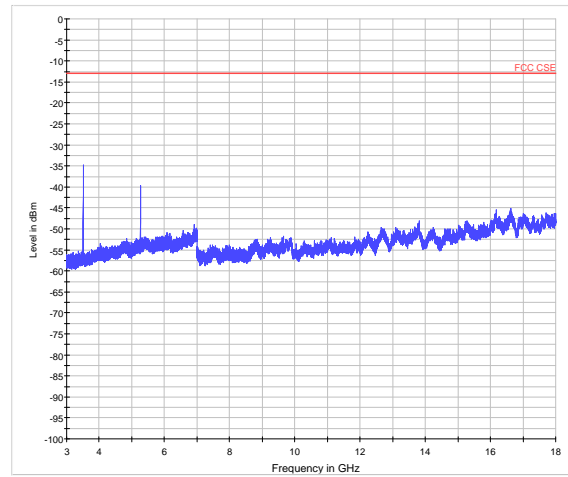

LTE Band 66 3MHz CH-High 30MHz~3GHz

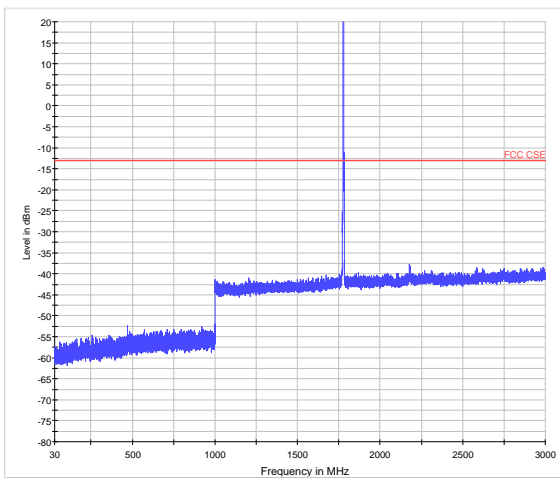

LTE Band 66 3MHz CH-High 3GHz~18GHz

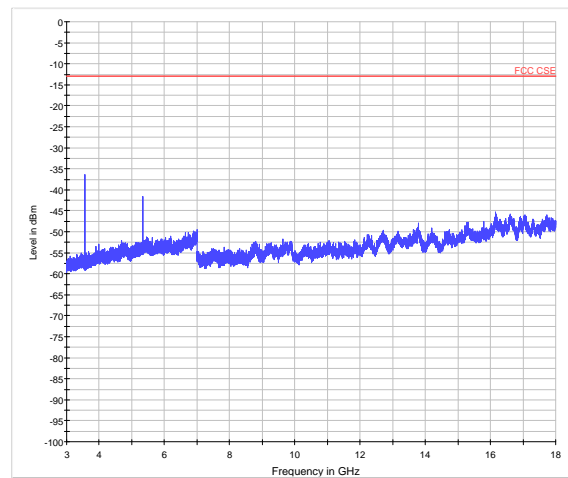



LTE Band 66 5MHz CH-Low 30MHz~3GHz

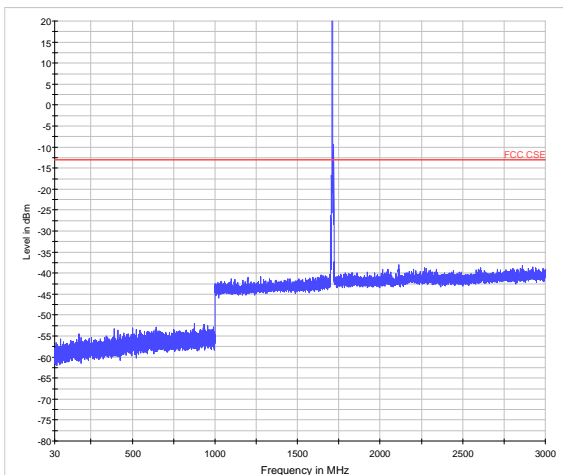

LTE Band 66 5MHz CH-Low 3GHz~18GHz

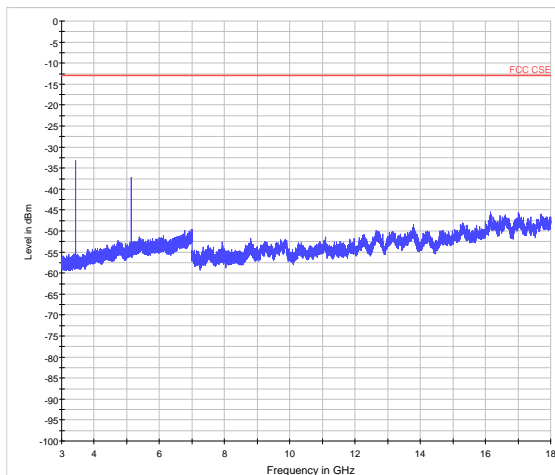

LTE Band 66 5MHz CH-Middle 30MHz~3GHz

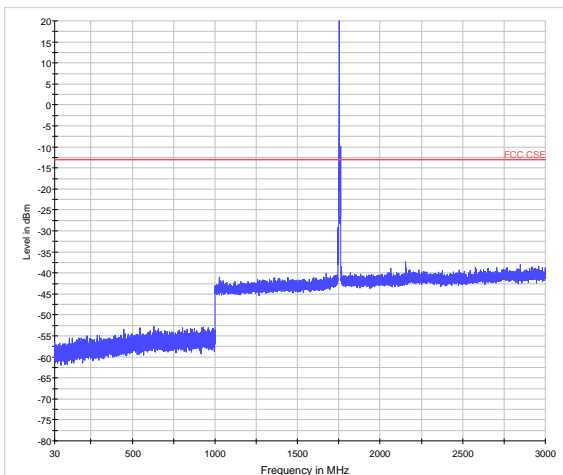

LTE Band 66 5MHz CH-Middle 3GHz~18GHz

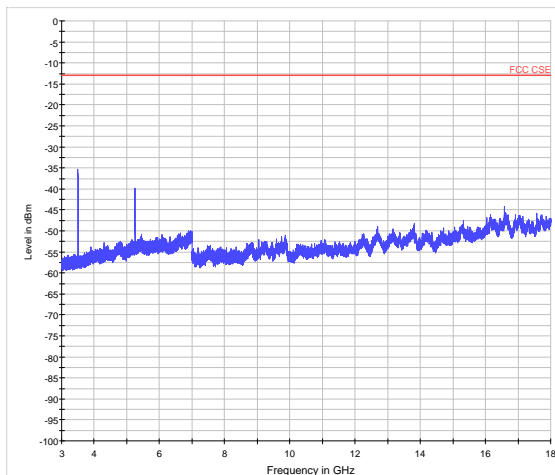

LTE Band 66 5MHz CH-High 30MHz~3GHz

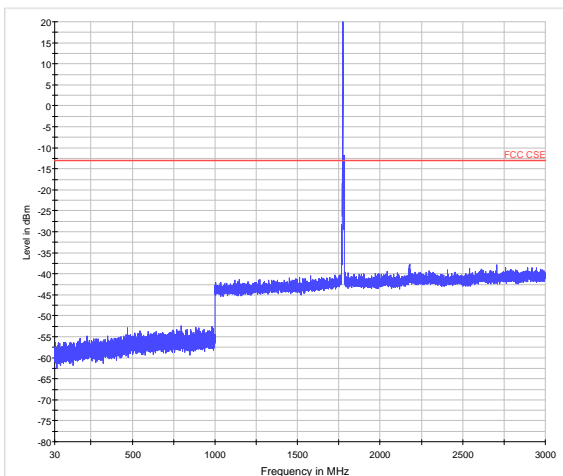

LTE Band 66 5MHz CH-High 3GHz~18GHz

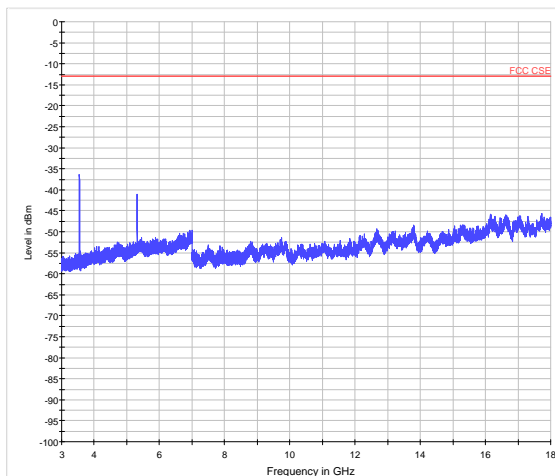



LTE Band 66 10MHz CH-Low 30MHz~3GHz

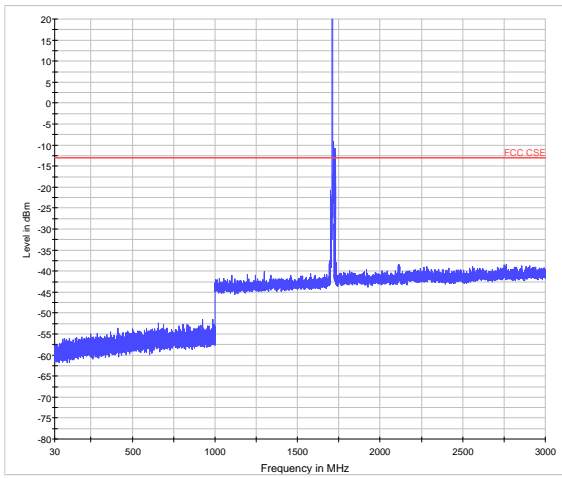

LTE Band 66 10MHz CH-Low 3GHz~18GHz

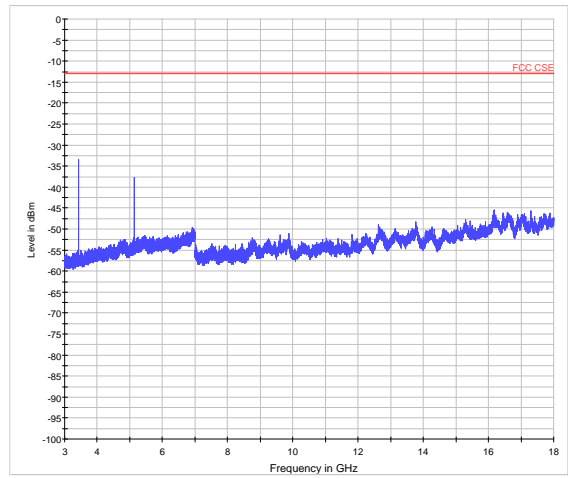

LTE Band 66 10MHz CH-Middle 30MHz~3GHz

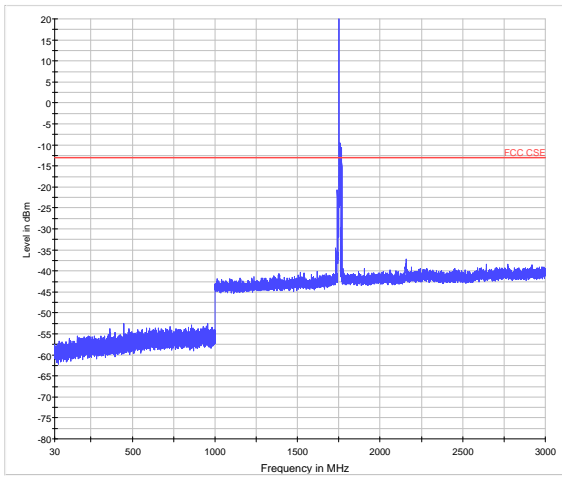

LTE Band 66 10MHz CH-Middle 3GHz~18GHz

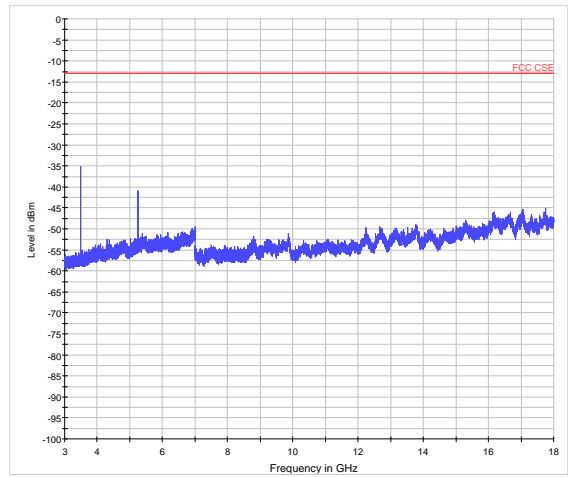

LTE Band 66 10MHz CH-High 30MHz~3GHz

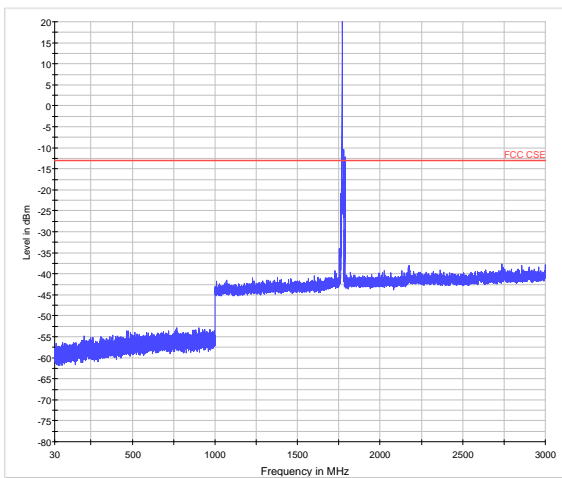

LTE Band 66 10MHz CH-High 3GHz~18GHz

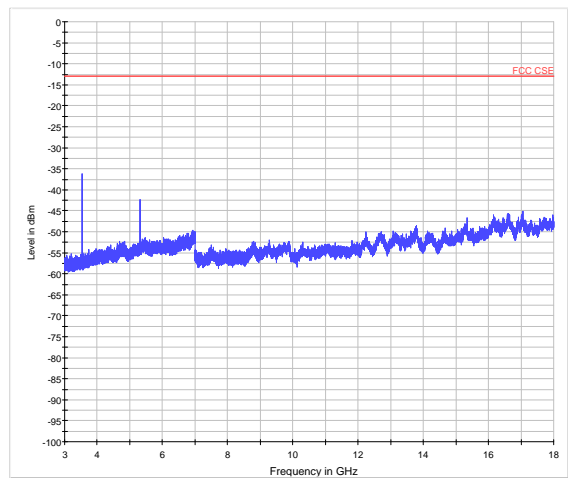



LTE Band 66 15MHz CH-Low 30MHz~3GHz

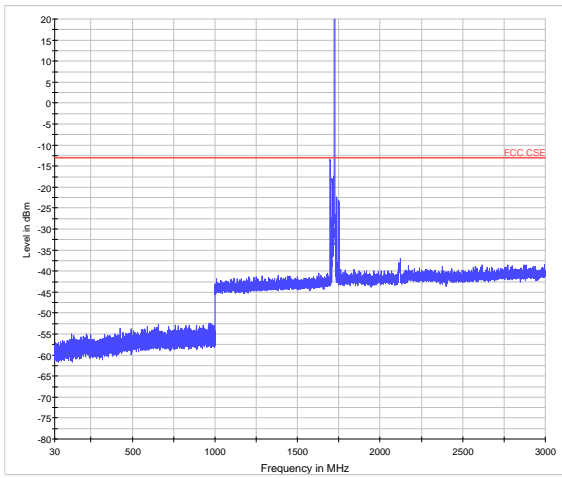

LTE Band 66 15MHz CH-Low 3GHz~18GHz

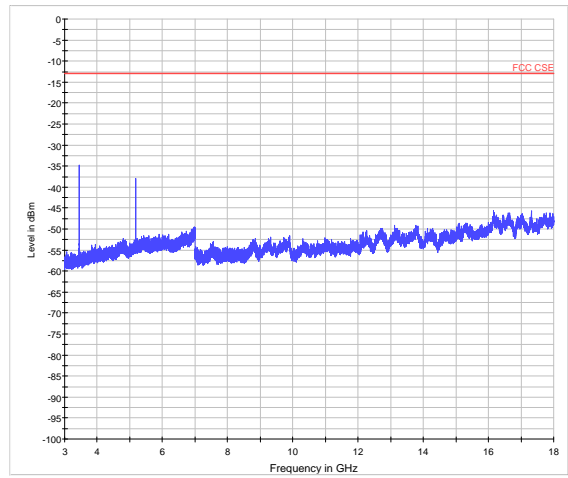

LTE Band 66 15MHz CH-Middle 30MHz~3GHz

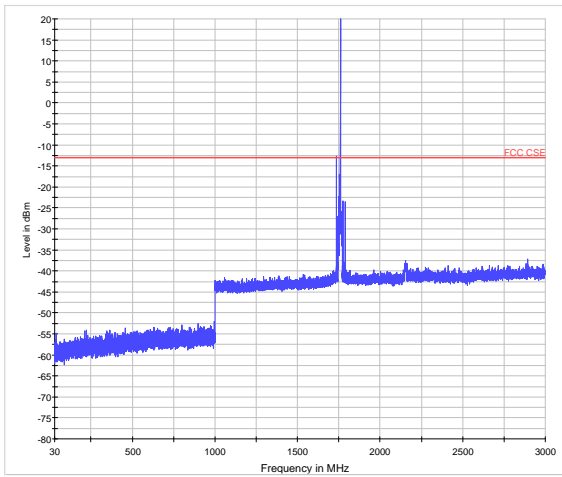

LTE Band 66 15MHz CH-Middle 3GHz~18GHz

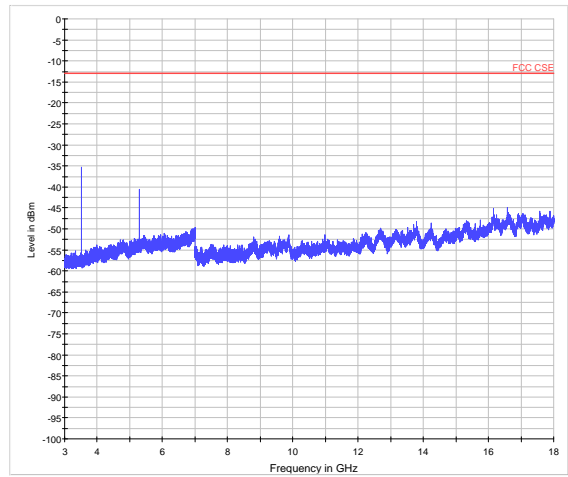

LTE Band 66 15MHz CH-High 30MHz~3GHz

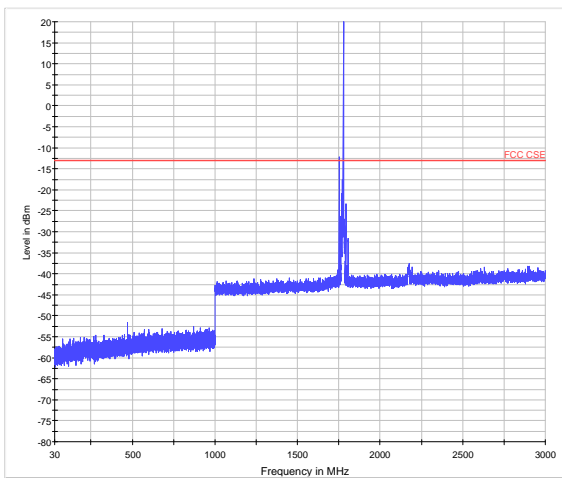

LTE Band 66 15MHz CH-High 3GHz~18GHz

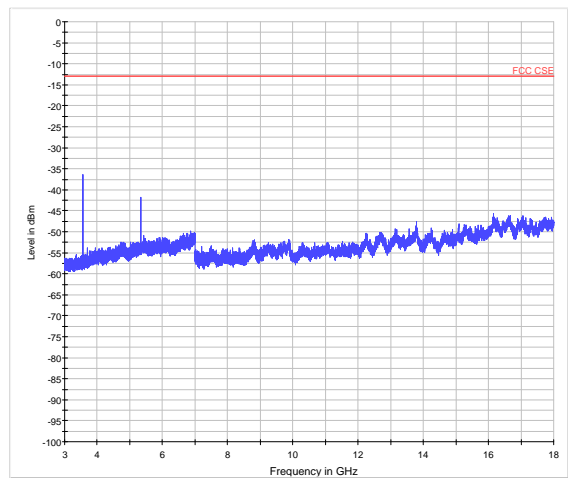



LTE Band 66 20MHz CH-Low 30MHz~3GHz

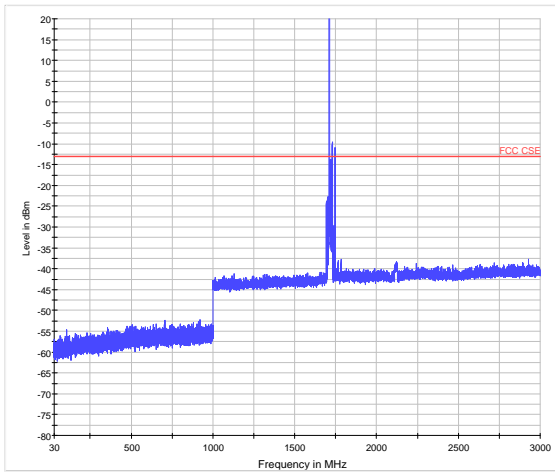

LTE Band 66 20MHz CH-Low 3GHz~18GHz

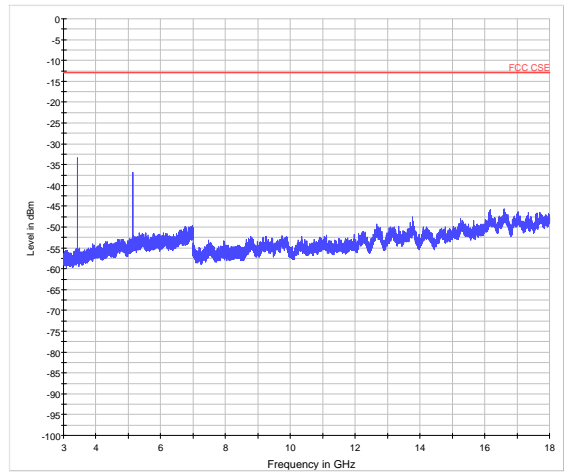

LTE Band 66 20MHz CH-Middle 30MHz~3GHz

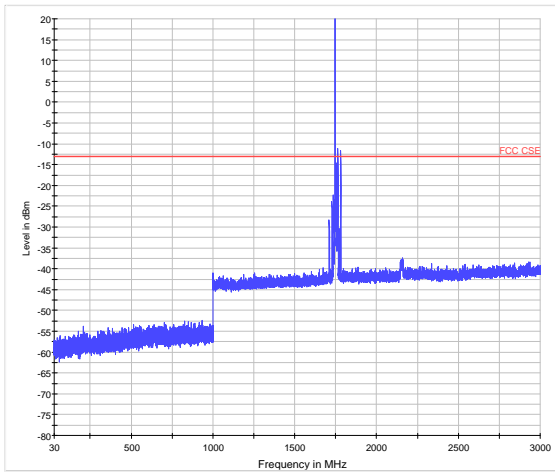

LTE Band 66 20MHz CH-Middle 3GHz~18GHz

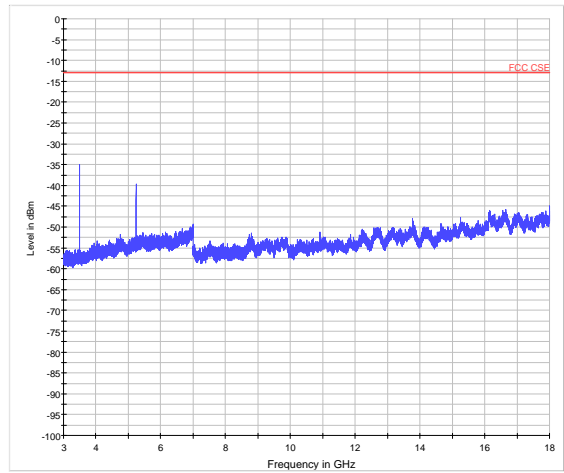

LTE Band 66 20MHz CH-High 30MHz~3GHz

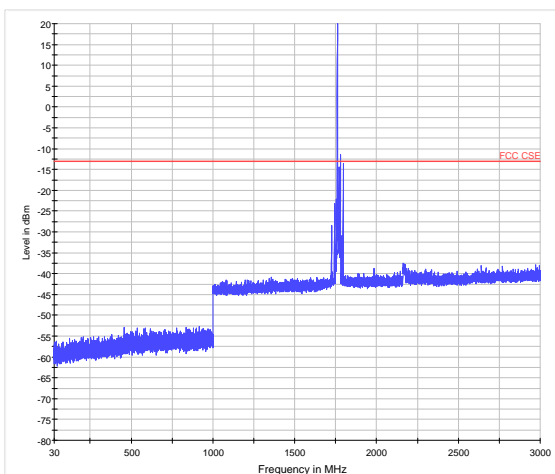

LTE Band 66 20MHz CH-High 3GHz~18GHz

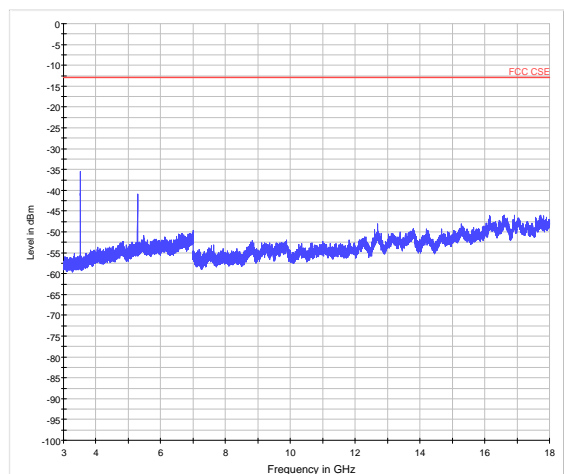

If disturbances were found more than 20dB below limit line, the mark is not required for the EUT.

The signal beyond the limit is carrier in the following plots.

Test Data File Name	Frequency (MHz)	Level (dBm)	Limit (dBm)	Margin (dB)
CSE_V9_1#_LTE B7_CHLOW_5M_RB1_3-18GHz	7500.8	-39.65	-25	14.65
CSE_V9_1#_LTE B7_CHLOW_10M_RB1_3-18GHz	7501.9	-39.56	-25	14.56
CSE_V9_1#_LTE B7_CHHIGH_10M_RB1_3-18GHz	7681.9	-43.88	-25	18.88
CSE_V9_1#_LTE B7_CHLOW_15M_RB1_3-18GHz	7542.4	-41.81	-25	16.81
CSE_V9_1#_LTE B7_CHHIGH_15M_RB1_3-18GHz	7707.8	-44.39	-25	19.39
CSE_V9_1#_LTE B7_CHLOW_20M_RB1_3-18GHz	7503.4	-40.28	-25	15.28
CSE_V9_1#_LTE B7_CHMID_20M_RB1_3-18GHz	7578.4	-43.98	-25	18.98
CSE_V9_1#_LTE B7_CHHIGH_20M_RB1_3-18GHz	7653.4	-43.25	-25	18.25
CSE_V9_1#_LTE B12_CHLOW_1.4M_RB1_1-3GHz	1398.5	-29.12	-13	16.12
CSE_V9_1#_LTE B12_CHMID_1.4M_RB1_1-3GHz	1414.0	-31.05	-13	18.05
CSE_V9_1#_LTE B12_CHHIGH_1.4M_RB1_1-3GHz	1429.5	-30.74	-13	17.74
CSE_V9_1#_LTE B12_CHLOW_3M_RB1_1-3GHz	1398.5	-29.37	-13	16.37
CSE_V9_1#_LTE B12_CHMID_3M_RB1_1-3GHz	1412.5	-31.04	-13	18.04
CSE_V9_1#_LTE B12_CHHIGH_3M_RB1_1-3GHz	1426.5	-30.47	-13	17.47
CSE_V9_1#_LTE B12_CHLOW_5M_RB1_1-3GHz	1398.5	-28.88	-13	15.88
CSE_V9_1#_LTE B12_CHMID_5M_RB1_1-3GHz	1410.5	-30.97	-13	17.97
CSE_V9_1#_LTE B12_CHHIGH_5M_RB1_1-3GHz	1422.5	-30.15	-13	17.15
CSE_V9_1#_LTE B12_CHLOW_10M_RB1_1-3GHz	1399.3	-29.20	-13	16.20
CSE_V9_1#_LTE B12_CHMID_10M_RB1_1-3GHz	1406.0	-31.10	-13	18.10
CSE_V9_1#_LTE B12_CHHIGH_10M_RB1_1-3GHz	1399.3	-29.23	-13	16.23
CSE_V9_1#_LTE B66_CHLOW_3M_RB1_3-18GHz	3420.4	-32.81	-13	19.81

5.8 Radiates Spurious Emission

Ambient condition

Temperature	Relative humidity	Pressure
23°C ~25°C	45%~50%	101.5kPa

Method of Measurement

1. The testing follows FCC KDB 971168 v03 Section 5.8 and ANSI/TIA-603-D-2010.
2. The EUT is placed on a turntable 0.8 meters above the ground in the chamber, 3 meter away from the antenna. The maximal emission value is acquired by adjusting the antenna height, polarisation and turntable azimuth. Normally, the height range of antenna is 1 m to 4 m, the azimuth range of turntable is 0° to 360°, and the receive antenna has two polarizations Vertical (V) and Horizontal (H).
3. A log-periodic antenna or double-ridged waveguide horn antenna shall be substituted in place of the EUT. The log-periodic antenna will be driven by a signal generator and the level will be adjusted till the same power value on the spectrum analyzer or receiver. The level of the spurious emissions can be calculated through the level of the signal generator, cable loss, the gain of the substitution antenna and the reading of the spectrum analyzer or receiver.
4. The EUT is then put into continuously transmitting mode at its maximum power level during the test. Set Test Receiver or Spectrum RBW=1MHz, VBW=3MHz, And the maximum value of the receiver should be recorded as (Pr).
5. The EUT shall be replaced by a substitution antenna. In the chamber, an substitution antenna for the frequency band of interest is placed at the reference point of the chamber. An RF Signal source for the frequency band of interest is connected to the substitution antenna with a cable that has been constructed to not interfere with the radiation pattern of the antenna. A power (PMea) is applied to the input of the substitution antenna, and adjust the level of the signal generator output until the value of the receiver reach the previously recorded (Pr). The power of signal source (PMea) is recorded. The test should be performed by rotating the test item and adjusting the receiving antenna polarization.
6. A amplifier should be connected to the Signal Source output port. And the cable should be connect between the Amplifier and the Substitution Antenna. The cable loss (Pcl) ,the Substitution Antenna Gain (Ga) and the Amplifier Gain (PAg) should be recorded after test.
7. The measurement results are obtained as described below:

$$\text{Power(EIRP)} = \text{PMea} - \text{PAg} - \text{Pcl} + \text{Ga}$$
 The measurement results are amend as described below:

$$\text{Power(EIRP)} = \text{PMea} - \text{Pcl} + \text{Ga}$$
8. This value is EIRP since the measurement is calibrated using an antenna of known gain (2.15 dBi) and known input power. ERP can be calculated from EIRP by subtracting the gain of the dipole, $\text{ERP} = \text{EIRP} - 2.15\text{dBi}$.

Test setup

30MHz~~~ 1GHz

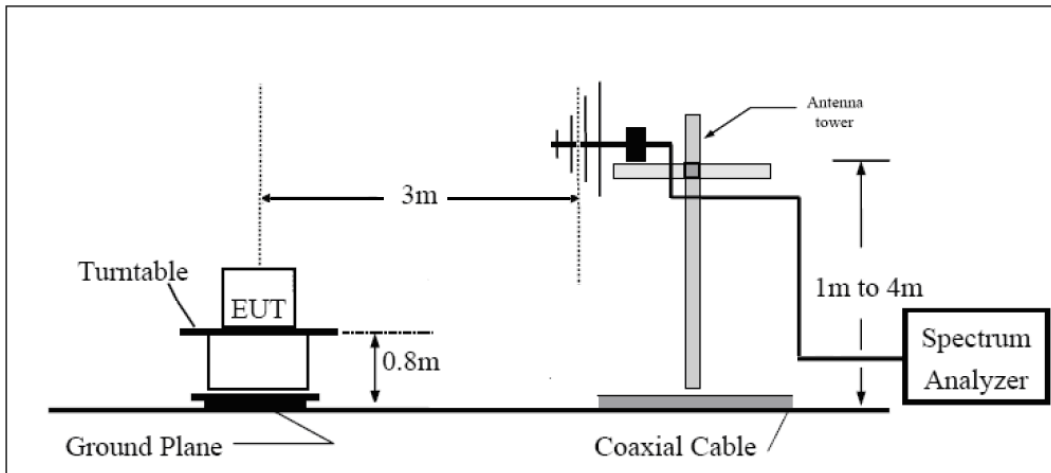

Above 1GHz

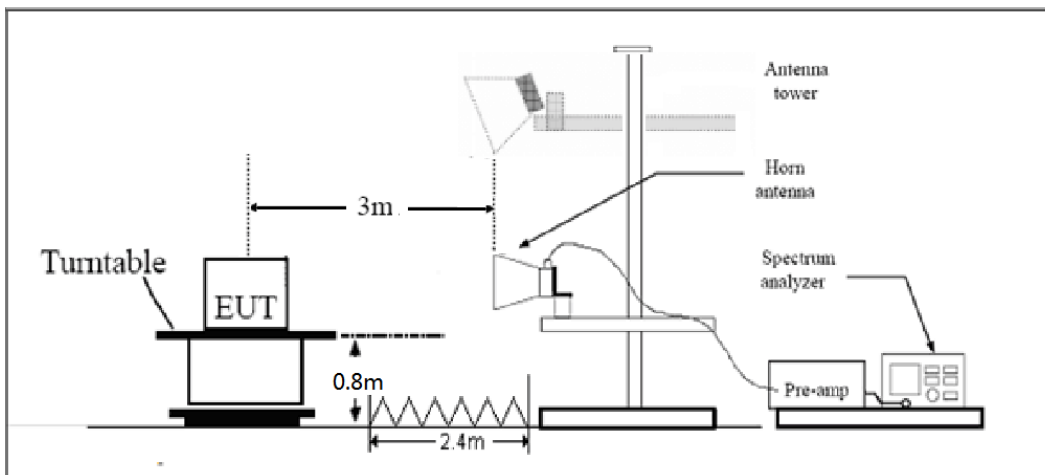

Note: Area side:2.4mX3.6m

The radiated emission was measured in the following position: EUT stand-up position (Z axis), lie-down position (X, Y axis). The worst emission was found in lie-down position (X axis) and the worst case was recorded.

Limits

LTE -4/66 Rule Part 27.53(h) specifies that “for operations in the 1695-1710 MHz, 1710-1755 MHz, 1755-1780 MHz, 1915-1920 MHz, 1995-2000 MHz, 2000-2020 MHz, 2110-2155 MHz, 2155-2180 MHz, and 2180-2200 bands, the power of any emission outside a licensee's frequency block shall be attenuated below the transmitter power (P) in watts by at least $43 + 10 \log_{10} (P)$ dB..”

LTE -12 Rule Part 27.53 (g) For operations in the 600 MHz band and the 698-746 MHz band, the power of any emission outside a licensee's frequency band(s) of operation shall be attenuated below the transmitter power (P) within the licensed band(s) of operation, measured in watts, by at least $43 + 10 \log (P)$ dB. Compliance with this provision is based on the use of measurement instrumentation employing a resolution bandwidth of 100 kilohertz or greater. However, in the 100 kilohertz bands



immediately outside and adjacent to a licensee's frequency block, a resolution bandwidth of at least 30 kHz may be employed.

LTE -7Rule Part 27.53(m) $55 + 10 \log (P)$ dB on all frequencies more than X megahertz from the channel edge, where X is the greater of 6 megahertz or the actual emission bandwidth as defined in paragraph (m)(4) of this section.

LTE 4/12/66 Limit	-13 dBm
LTE 7Limit	-25 dBm

Measurement Uncertainty

The assessed measurement uncertainty to ensure 95% confidence level for the normal distribution is with the coverage factor $k = \pm 1.96$, $U = \pm 3.55$ dB.

Test Result

LTE Band 4 QPSK 1.4MHz CH-Low, RB 1

Harmonic	Frequency (MHz)	SG (dBm)	Cable Loss (dB)	Gain (dBi)	Antenna Polarization	EIRP Level (dBm)	Limit (dBm)	Margin (dB)	Azimuth (deg)
2	3421.4	-54.15	2.6	10.15	Horizontal	-46.6	-13.00	33.6	315
3	5131.1	-56.05	2.4	11.35	Horizontal	-47.1	-13.00	34.1	270
4	6842.8	-50.55	4.5	10.85	Horizontal	-44.2	-13.00	31.2	135
5	8553.5	-48.55	5.1	11.35	Horizontal	-42.3	-13.00	29.3	225
6	10264.2	-47.85	5.3	11.95	Horizontal	-41.2	-13.00	28.2	180
7	11974.9	-47.25	5.5	13.55	Horizontal	-39.2	-13.00	26.2	45
8	13685.6	-44.75	6.3	13.75	Horizontal	-37.3	-13.00	24.3	315
9	15396.3	-46.75	6.7	13.85	Horizontal	-39.6	-13.00	26.6	270
10	17107.0	-43.55	6.8	14.25	Horizontal	-36.1	-13.00	23.1	135

Note: 1. The other Spurious RF Radiated emissions level is no more than noise floor.
 2. The worst emission was found in the antenna is Horizontal position.

LTE Band 4 QPSK 1.4MHz CH-Middle, RB 1

Harmonic	Frequency (MHz)	SG (dBm)	Cable Loss (dB)	Gain (dBi)	Antenna Polarization	EIRP Level (dBm)	Limit (dBm)	Margin (dB)	Azimuth (deg)
2	3464.3	-55.65	2.6	10.75	Horizontal	-47.5	-13.00	34.5	135
3	5197.5	-56.45	2.4	11.05	Horizontal	-47.8	-13.00	34.8	225
4	6930.0	-49.75	4.5	11.15	Horizontal	-43.1	-13.00	30.1	180
5	8662.5	-47.75	5.1	11.35	Horizontal	-41.5	-13.00	28.5	225
6	10395.0	-46.25	5.3	11.95	Horizontal	-39.6	-13.00	26.6	180
7	12127.5	-48.05	5.5	13.55	Horizontal	-40.0	-13.00	27.0	45
8	13860.0	-43.75	6.3	13.75	Horizontal	-36.3	-13.00	23.3	270
9	15592.5	-46.85	6.7	13.85	Horizontal	-39.7	-13.00	26.7	90
10	17325.0	-42.75	6.8	14.25	Horizontal	-35.3	-13.00	22.3	180

Note: 1. The other Spurious RF Radiated emissions level is no more than noise floor.
 2. The worst emission was found in the antenna is Horizontal position.



LTE Band 4 QPSK 1.4MHz CH-High, RB 1

Harmonic	Frequency (MHz)	SG (dBm)	Cable Loss (dB)	Gain (dBi)	Antenna Polarization	EIRP Level (dBm)	Limit (dBm)	Margin (dB)	Azimuth (deg)
2	3507.8	-53.35	2.6	10.15	Horizontal	-45.8	-13.00	32.8	315
3	5261.6	-56.95	2.4	11.05	Horizontal	-48.3	-13.00	35.3	270
4	7017.2	38.35	4.5	11.15	Horizontal	45.0	-13.00	-58.0	135
5	8771.5	-47.95	5.1	11.35	Horizontal	-41.7	-13.00	28.7	225
6	10525.8	-45.75	5.3	11.95	Horizontal	-39.1	-13.00	26.1	180
7	12280.1	-47.65	5.5	13.55	Horizontal	-39.6	-13.00	26.6	45
8	14034.4	-44.05	6.3	13.75	Horizontal	-36.6	-13.00	23.6	315
9	15788.7	-45.55	6.7	13.85	Horizontal	-38.4	-13.00	25.4	270
10	17543.0	-44.55	6.8	14.25	Horizontal	-37.1	-13.00	24.1	135

Note: 1.The other Spurious RF Radiated emissions level is no more than noise floor.

2. The worst emission was found in the antenna is Horizontal position.

LTE Band 4 QPSK 3MHz CH-Low, RB 1

Harmonic	Frequency (MHz)	SG (dBm)	Cable Loss (dB)	Gain (dBi)	Antenna Polarization	EIRP Level (dBm)	Limit (dBm)	Margin (dB)	Azimuth (deg)
2	3423.0	-53.85	2.6	10.15	Horizontal	-46.3	-13.00	33.3	270
3	5134.5	-57.15	2.4	11.35	Horizontal	-48.2	-13.00	35.2	225
4	6846.0	-51.55	4.5	10.85	Horizontal	-45.2	-13.00	32.2	315
5	8557.5	-48.25	5.1	11.35	Horizontal	-42.0	-13.00	29.0	270
6	10269.0	-47.95	5.3	11.95	Horizontal	-41.3	-13.00	28.3	135
7	11980.5	-47.55	5.5	13.55	Horizontal	-39.5	-13.00	26.5	225
8	13692.0	-44.95	6.3	13.75	Horizontal	-37.5	-13.00	24.5	180
9	15403.5	-46.75	6.7	13.85	Horizontal	-39.6	-13.00	26.6	45
10	17115.0	-45.25	6.8	14.25	Horizontal	-37.8	-13.00	24.8	315

Note: 1.The other Spurious RF Radiated emissions level is no more than noise floor.

2. The worst emission was found in the antenna is Horizontal position.

LTE Band 4 QPSK 3MHz CH-Middle, RB 1

Harmonic	Frequency (MHz)	SG (dBm)	Cable Loss (dB)	Gain (dBi)	Antenna Polarization	EIRP Level (dBm)	Limit (dBm)	Margin (dB)	Azimuth (deg)
2	3465.0	-55.95	2.6	10.75	Horizontal	-47.8	-13.00	34.8	270
3	5197.5	-56.35	2.4	11.05	Horizontal	-47.7	-13.00	34.7	135
4	6930.0	-51.65	4.5	11.15	Horizontal	-45.0	-13.00	32.0	90
5	8662.5	-47.35	5.1	11.35	Horizontal	-41.1	-13.00	28.1	225
6	10395.0	-47.15	5.3	11.95	Horizontal	-40.5	-13.00	27.5	180
7	12127.5	-46.85	5.5	13.55	Horizontal	-38.8	-13.00	25.8	225
8	13860.0	-44.85	6.3	13.75	Horizontal	-37.4	-13.00	24.4	180
9	15592.5	-47.85	6.7	13.85	Horizontal	-40.7	-13.00	27.7	45
10	17325.0	-44.25	6.8	14.25	Horizontal	-36.8	-13.00	23.8	315

Note: 1.The other Spurious RF Radiated emissions level is no more than noise floor.
2. The worst emission was found in the antenna is Horizontal position.

LTE Band 4 QPSK 3MHz CH-High, RB 1

Harmonic	Frequency (MHz)	SG (dBm)	Cable Loss (dB)	Gain (dBi)	Antenna Polarization	EIRP Level (dBm)	Limit (dBm)	Margin (dB)	Azimuth (deg)
2	3504.8	-53.75	2.6	10.15	Horizontal	-46.2	-13.00	33.2	135
3	5256.8	-56.25	2.4	11.05	Horizontal	-47.6	-13.00	34.6	315
4	7014.0	-52.55	4.5	11.15	Horizontal	-45.9	-13.00	32.9	90
5	8767.5	-48.65	5.1	11.35	Horizontal	-42.4	-13.00	29.4	180
6	10521.0	-46.55	5.3	11.95	Horizontal	-39.9	-13.00	26.9	225
7	12274.5	-48.05	5.5	13.55	Horizontal	-40.0	-13.00	27.0	90
8	14028.0	-44.15	6.3	13.75	Horizontal	-36.7	-13.00	23.7	270
9	15781.5	-46.25	6.7	13.85	Horizontal	-39.1	-13.00	26.1	135
10	17535.0	-44.55	6.8	14.25	Horizontal	-37.1	-13.00	24.1	270

Note: 1.The other Spurious RF Radiated emissions level is no more than noise floor.
2. The worst emission was found in the antenna is Horizontal position.



LTE Band 4 QPSK 5MHz CH-Low, RB 1

Harmonic	Frequency (MHz)	SG (dBm)	Cable Loss (dB)	Gain (dBi)	Antenna Polarization	EIRP Level (dBm)	Limit (dBm)	Margin (dB)	Azimuth (deg)
2	3425.0	-53.15	2.6	10.15	Horizontal	-45.6	-13.00	32.6	315
3	5131.1	-56.75	2.4	11.35	Horizontal	-47.8	-13.00	34.8	270
4	6850.0	-51.85	4.5	10.85	Horizontal	-45.5	-13.00	32.5	45
5	8562.5	-48.05	5.1	11.35	Horizontal	-41.8	-13.00	28.8	225
6	10275.0	-47.55	5.3	11.95	Horizontal	-40.9	-13.00	27.9	315
7	11987.5	-47.05	5.5	13.55	Horizontal	-39.0	-13.00	26.0	90
8	13700.0	-45.65	6.3	13.75	Horizontal	-38.2	-13.00	25.2	45
9	15412.5	-45.75	6.7	13.85	Horizontal	-38.6	-13.00	25.6	315
10	17125.0	-44.45	6.8	14.25	Horizontal	-37.0	-13.00	24.0	180

Note: 1.The other Spurious RF Radiated emissions level is no more than noise floor.
2. The worst emission was found in the antenna is Horizontal position.

LTE Band 4 QPSK 5MHz CH-Middle, RB 1

Harmonic	Frequency (MHz)	SG (dBm)	Cable Loss (dB)	Gain (dBi)	Antenna Polarization	EIRP Level (dBm)	Limit (dBm)	Margin (dB)	Azimuth (deg)
2	3460.5	-55.75	2.6	10.75	Horizontal	-47.6	-13.00	34.6	135
3	5191.5	-55.35	2.4	11.05	Horizontal	-46.7	-13.00	33.7	315
4	6930.0	-52.35	4.5	11.15	Horizontal	-45.7	-13.00	32.7	90
5	8662.5	-48.15	5.1	11.35	Horizontal	-41.9	-13.00	28.9	180
6	10395.0	-46.85	5.3	11.95	Horizontal	-40.2	-13.00	27.2	270
7	12127.5	-47.05	5.5	13.55	Horizontal	-39.0	-13.00	26.0	315
8	13860.0	-44.45	6.3	13.75	Horizontal	-37.0	-13.00	24.0	225
9	15592.5	-47.35	6.7	13.85	Horizontal	-40.2	-13.00	27.2	45
10	17325.0	-43.75	6.8	14.25	Horizontal	-36.3	-13.00	23.3	180

Note: 1.The other Spurious RF Radiated emissions level is no more than noise floor.
2. The worst emission was found in the antenna is Horizontal position.

LTE Band 4 QPSK 5MHz CH-High, RB 1

Harmonic	Frequency (MHz)	SG (dBm)	Cable Loss (dB)	Gain (dBi)	Antenna Polarization	EIRP Level (dBm)	Limit (dBm)	Margin (dB)	Azimuth (deg)
2	3500.6	-53.95	2.6	10.15	Horizontal	-46.4	-13.00	33.4	90
3	5250.8	-57.25	2.4	11.05	Horizontal	-48.6	-13.00	35.6	315
4	7010.0	-52.15	4.5	11.15	Horizontal	-45.5	-13.00	32.5	270
5	8762.5	-49.55	5.1	11.35	Horizontal	-43.3	-13.00	30.3	45
6	10515.0	-46.35	5.3	11.95	Horizontal	-39.7	-13.00	26.7	180
7	12267.5	-46.15	5.5	13.55	Horizontal	-38.1	-13.00	25.1	90
8	14020.0	-44.25	6.3	13.75	Horizontal	-36.8	-13.00	23.8	225
9	15772.5	-45.55	6.7	13.85	Horizontal	-38.4	-13.00	25.4	270
10	17525.0	-44.75	6.8	14.25	Horizontal	-37.3	-13.00	24.3	315

Note: 1.The other Spurious RF Radiated emissions level is no more than noise floor.

2. The worst emission was found in the antenna is Horizontal position.

LTE Band 4 QPSK 10MHz CH-Low, RB 1

Harmonic	Frequency (MHz)	SG (dBm)	Cable Loss (dB)	Gain (dBi)	Antenna Polarization	EIRP Level (dBm)	Limit (dBm)	Margin (dB)	Azimuth (deg)
2	3420.8	-54.05	2.6	10.15	Horizontal	-46.5	-13.00	33.5	270
3	5131.9	-55.65	2.4	11.35	Horizontal	-46.7	-13.00	33.7	180
4	6860.0	-51.25	4.5	10.85	Horizontal	-44.9	-13.00	31.9	45
5	8575.0	-48.05	5.1	11.35	Horizontal	-41.8	-13.00	28.8	225
6	10290.0	-47.65	5.3	11.95	Horizontal	-41.0	-13.00	28.0	180
7	12005.0	-47.25	5.5	13.55	Horizontal	-39.2	-13.00	26.2	315
8	13720.0	-44.85	6.3	13.75	Horizontal	-37.4	-13.00	24.4	45
9	15435.0	-46.35	6.7	13.85	Horizontal	-39.2	-13.00	26.2	225
10	17150.0	-43.95	6.8	14.25	Horizontal	-36.5	-13.00	23.5	90

Note: 1.The other Spurious RF Radiated emissions level is no more than noise floor.

2. The worst emission was found in the antenna is Horizontal position.



LTE Band 4 QPSK 10MHz CH-Middle, RB 1

Harmonic	Frequency (MHz)	SG (dBm)	Cable Loss (dB)	Gain (dBi)	Antenna Polarization	EIRP Level (dBm)	Limit (dBm)	Margin (dB)	Azimuth (deg)
2	3456.0	-55.95	2.6	10.75	Horizontal	-47.8	-13.00	34.8	45
3	5184.4	-55.95	2.4	11.05	Horizontal	-47.3	-13.00	34.3	180
4	6930.0	-52.15	4.5	11.15	Horizontal	-45.5	-13.00	32.5	90
5	8662.5	-49.15	5.1	11.35	Horizontal	-42.9	-13.00	29.9	270
6	10395.0	-46.75	5.3	11.95	Horizontal	-40.1	-13.00	27.1	45
7	12127.5	-45.95	5.5	13.55	Horizontal	-37.9	-13.00	24.9	225
8	13860.0	-45.45	6.3	13.75	Horizontal	-38.0	-13.00	25.0	315
9	15592.5	-47.55	6.7	13.85	Horizontal	-40.4	-13.00	27.4	180
10	17325.0	-43.55	6.8	14.25	Horizontal	-36.1	-13.00	23.1	135

Note: 1.The other Spurious RF Radiated emissions level is no more than noise floor.

2. The worst emission was found in the antenna is Horizontal position.

LTE Band 4 QPSK 10MHz CH-High, RB 1

Harmonic	Frequency (MHz)	SG (dBm)	Cable Loss (dB)	Gain (dBi)	Antenna Polarization	EIRP Level (dBm)	Limit (dBm)	Margin (dB)	Azimuth (deg)
2	3490.9	-53.05	2.6	10.15	Horizontal	-45.5	-13.00	32.5	315
3	5236.9	-56.35	2.4	11.05	Horizontal	-47.7	-13.00	34.7	90
4	7000.0	-51.95	4.5	11.15	Horizontal	-45.3	-13.00	32.3	270
5	8750.0	-47.55	5.1	11.35	Horizontal	-41.3	-13.00	28.3	45
6	10500.0	-46.45	5.3	11.95	Horizontal	-39.8	-13.00	26.8	225
7	12250.0	-46.55	5.5	13.55	Horizontal	-38.5	-13.00	25.5	180
8	14000.0	-45.55	6.3	13.75	Horizontal	-38.1	-13.00	25.1	270
9	15750.0	-46.95	6.7	13.85	Horizontal	-39.8	-13.00	26.8	315
10	17500.0	-44.75	6.8	14.25	Horizontal	-37.3	-13.00	24.3	180

Note: 1.The other Spurious RF Radiated emissions level is no more than noise floor.

2. The worst emission was found in the antenna is Horizontal position.

LTE Band 4 QPSK 15MHz CH Low, RB 1

Harmonic	Frequency (MHz)	SG (dBm)	Cable Loss (dB)	Gain (dBi)	Antenna Polarization	EIRP Level (dBm)	Limit (dBm)	Margin (dB)	Azimuth (deg)
2	3448.1	-53.05	2.6	10.15	Horizontal	-45.5	-13.00	32.5	225
3	5132.6	-55.55	2.4	11.35	Horizontal	-46.6	-13.00	33.6	180
4	6870.0	-51.25	4.5	10.85	Horizontal	-44.9	-13.00	31.9	270
5	8587.5	-48.95	5.1	11.35	Horizontal	-42.7	-13.00	29.7	45
6	10305.0	-47.75	5.3	11.95	Horizontal	-41.1	-13.00	28.1	135
7	12022.5	-48.55	5.5	13.55	Horizontal	-40.5	-13.00	27.5	90
8	13740.0	-45.65	6.3	13.75	Horizontal	-38.2	-13.00	25.2	135
9	15457.5	-47.15	6.7	13.85	Horizontal	-40.0	-13.00	27.0	225
10	17175.0	-44.85	6.8	14.25	Horizontal	-37.4	-13.00	24.4	315

Note: 1.The other Spurious RF Radiated emissions level is no more than noise floor.

2. The worst emission was found in the antenna is Horizontal position.

LTE Band 4 QPSK 15MHz CH-Middle, RB 1

Harmonic	Frequency (MHz)	SG (dBm)	Cable Loss (dB)	Gain (dBi)	Antenna Polarization	EIRP Level (dBm)	Limit (dBm)	Margin (dB)	Azimuth (deg)
2	3478.1	-59.95	2.6	10.75	Horizontal	-51.8	-13.00	38.8	180
3	5217.8	-55.55	2.4	11.05	Horizontal	-46.9	-13.00	33.9	315
4	6930.0	-51.85	4.5	11.15	Horizontal	-45.2	-13.00	32.2	90
5	8662.5	-48.05	5.1	11.35	Horizontal	-41.8	-13.00	28.8	225
6	10395.0	-46.05	5.3	11.95	Horizontal	-39.4	-13.00	26.4	270
7	12127.5	-47.75	5.5	13.55	Horizontal	-39.7	-13.00	26.7	45
8	13860.0	-44.35	6.3	13.75	Horizontal	-36.9	-13.00	23.9	180
9	15592.5	-45.95	6.7	13.85	Horizontal	-38.8	-13.00	25.8	90
10	17325.0	-43.95	6.8	14.25	Horizontal	-36.5	-13.00	23.5	135

Note: 1.The other Spurious RF Radiated emissions level is no more than noise floor.

2. The worst emission was found in the antenna is Horizontal position.



LTE Band 4 QPSK 15MHz CH-High, RB 1

Harmonic	Frequency (MHz)	SG (dBm)	Cable Loss (dB)	Gain (dBi)	Antenna Polarization	EIRP Level (dBm)	Limit (dBm)	Margin (dB)	Azimuth (deg)
2	3508.1	-54.45	2.6	10.15	Horizontal	-46.9	-13.00	33.9	225
3	5262.8	-54.85	2.4	11.05	Horizontal	-46.2	-13.00	33.2	45
4	6990.0	-52.55	4.5	11.15	Horizontal	-45.9	-13.00	32.9	270
5	8737.5	-49.35	5.1	11.35	Horizontal	-43.1	-13.00	30.1	315
6	10485.0	-47.05	5.3	11.95	Horizontal	-40.4	-13.00	27.4	90
7	12232.5	-47.65	5.5	13.55	Horizontal	-39.6	-13.00	26.6	225
8	13980.0	-45.85	6.3	13.75	Horizontal	-38.4	-13.00	25.4	45
9	15727.5	-46.65	6.7	13.85	Horizontal	-39.5	-13.00	26.5	180
10	17475.0	-45.05	6.8	14.25	Horizontal	-37.6	-13.00	24.6	90

Note: 1.The other Spurious RF Radiated emissions level is no more than noise floor.
2. The worst emission was found in the antenna is Horizontal position.

LTE Band 4 QPSK 20MHz CH-Low, RB 1

Harmonic	Frequency (MHz)	SG (dBm)	Cable Loss (dB)	Gain (dBi)	Antenna Polarization	EIRP Level (dBm)	Limit (dBm)	Margin (dB)	Azimuth (deg)
2	3421.9	-56.85	2.6	10.15	Horizontal	-49.3	-13.00	36.3	315
3	5133.0	-56.25	2.4	11.35	Horizontal	-47.3	-13.00	34.3	270
4	6880.0	-51.85	4.5	10.85	Horizontal	-45.5	-13.00	32.5	45
5	8600.0	-48.65	5.1	11.35	Horizontal	-42.4	-13.00	29.4	225
6	10320.0	-47.75	5.3	11.95	Horizontal	-41.1	-13.00	28.1	180
7	12040.0	-46.95	5.5	13.55	Horizontal	-38.9	-13.00	25.9	270
8	13760.0	-44.85	6.3	13.75	Horizontal	-37.4	-13.00	24.4	90
9	15480.0	-47.55	6.7	13.85	Horizontal	-40.4	-13.00	27.4	90
10	17200.0	-44.35	6.8	14.25	Horizontal	-36.9	-13.00	23.9	225

Note: 1.The other Spurious RF Radiated emissions level is no more than noise floor.
2. The worst emission was found in the antenna is Horizontal position.

LTE Band 4 QPSK 20MHz CH-Middle, RB 1

Harmonic	Frequency (MHz)	SG (dBm)	Cable Loss (dB)	Gain (dBi)	Antenna Polarization	EIRP Level (dBm)	Limit (dBm)	Margin (dB)	Azimuth (deg)
2	3447.0	-56.25	2.6	10.75	Horizontal	-48.1	-13.00	35.1	45
3	5170.5	-56.25	2.4	11.05	Horizontal	-47.6	-13.00	34.6	225
4	6930.0	-52.45	4.5	11.15	Horizontal	-45.8	-13.00	32.8	270
5	8662.5	-48.65	5.1	11.35	Horizontal	-42.4	-13.00	29.4	90
6	10395.0	-46.55	5.3	11.95	Horizontal	-39.9	-13.00	26.9	225
7	12127.5	-46.95	5.5	13.55	Horizontal	-38.9	-13.00	25.9	315
8	13860.0	-44.55	6.3	13.75	Horizontal	-37.1	-13.00	24.1	180
9	15592.5	-46.95	6.7	13.85	Horizontal	-39.8	-13.00	26.8	45
10	17325.0	-44.95	6.8	14.25	Horizontal	-37.5	-13.00	24.5	180

Note: 1.The other Spurious RF Radiated emissions level is no more than noise floor.

2. The worst emission was found in the antenna is Horizontal position.

LTE Band 4 QPSK 20MHz CH-High, RB 1

Harmonic	Frequency (MHz)	SG (dBm)	Cable Loss (dB)	Gain (dBi)	Antenna Polarization	EIRP Level (dBm)	Limit (dBm)	Margin (dB)	Azimuth (deg)
2	3472.1	-55.15	2.6	10.15	Horizontal	-47.6	-13.00	34.6	315
3	5208.4	-56.55	2.4	11.05	Horizontal	-47.9	-13.00	34.9	225
4	6980.0	-52.05	4.5	11.15	Horizontal	-45.4	-13.00	32.4	45
5	8725.0	-48.85	5.1	11.35	Horizontal	-42.6	-13.00	29.6	180
6	10470.0	-45.65	5.3	11.95	Horizontal	-39.0	-13.00	26.0	270
7	12215.0	-47.55	5.5	13.55	Horizontal	-39.5	-13.00	26.5	315
8	13960.0	-44.75	6.3	13.75	Horizontal	-37.3	-13.00	24.3	90
9	15705.0	-45.85	6.7	13.85	Horizontal	-38.7	-13.00	25.7	180
10	17450.0	-44.45	6.8	14.25	Horizontal	-37.0	-13.00	24.0	135

Note: 1.The other Spurious RF Radiated emissions level is no more than noise floor.

2. The worst emission was found in the antenna is Horizontal position.



LTE Band 7 QPSK 5MHz CH-Low, RB 1

Harmonic	Frequency (MHz)	SG (dBm)	Cable Loss (dB)	Gain (dBi)	Antenna Polarization	EIRP Level (dBm)	Limit (dBm)	Margin (dB)	Azimuth (deg)
2	5005.0	-54.85	2.00	9.15	Horizontal	-47.7	-25.00	34.7	180
3	7507.5	-52.45	2.50	11.35	Horizontal	-43.6	-25.00	30.6	225
4	10010.0	-49.65	4.20	12.05	Horizontal	-41.8	-25.00	28.8	45
5	12512.5	-48.45	5.20	12.85	Horizontal	-40.8	-25.00	27.8	180
6	15015.0	-46.83	5.50	14.23	Horizontal	-38.1	-25.00	25.1	270
7	17517.5	-46.15	5.70	14.15	Horizontal	-37.7	-25.00	24.7	135
8	20020.0	-44.06	6.30	13.76	Horizontal	-36.6	-25.00	23.6	180
9	22522.5	-43.35	6.80	14.05	Horizontal	-36.1	-25.00	23.1	225
10	25025.0	-43.44	6.90	14.84	Horizontal	-35.5	-25.00	22.5	90

Note: 1.The other Spurious RF Radiated emissions level is no more than noise floor.

2. The worst emission was found in the antenna is Horizontal position.

LTE Band 7 QPSK 5MHz CH-Middle, RB 1

Harmonic	Frequency (MHz)	SG (dBm)	Cable Loss (dB)	Gain (dBi)	Antenna Polarization	EIRP Level (dBm)	Limit (dBm)	Margin (dB)	Azimuth (deg)
2	5070.0	-55.25	2.00	9.15	Horizontal	-48.1	-25.00	35.1	135
3	7605.0	-52.15	2.50	11.35	Horizontal	-43.3	-25.00	30.3	180
4	10140.0	-47.55	4.20	12.05	Horizontal	-39.7	-25.00	26.7	90
5	12675.0	-47.65	5.20	12.85	Horizontal	-40.0	-25.00	27.0	45
6	15210.0	-47.03	5.50	14.23	Horizontal	-38.3	-25.00	25.3	180
7	17745.0	-45.65	5.70	14.15	Horizontal	-37.2	-25.00	24.2	270
8	20280.0	-43.96	6.30	13.76	Horizontal	-36.5	-25.00	23.5	45
9	22815.0	-43.45	6.80	14.05	Horizontal	-36.2	-25.00	23.2	180
10	25350.0	-42.54	6.90	14.84	Horizontal	-34.6	-25.00	21.6	225

Note: 1.The other Spurious RF Radiated emissions level is no more than noise floor.

2. The worst emission was found in the antenna is Horizontal position.

LTE Band 7 QPSK 5MHz CH-High, RB 1



Harmonic	Frequency (MHz)	SG (dBm)	Cable Loss (dB)	Gain (dBi)	Antenna Polarization	EIRP Level (dBm)	Limit (dBm)	Margin (dB)	Azimuth (deg)
2	5135.0	-55.25	2.00	9.15	Horizontal	-48.1	-25.00	35.1	225
3	7702.5	-52.15	2.50	11.35	Horizontal	-43.3	-25.00	30.3	45
4	10270.0	-48.05	4.20	12.05	Horizontal	-40.2	-25.00	27.2	90
5	12837.5	-46.15	5.20	12.85	Horizontal	-38.5	-25.00	25.5	180
6	15405.0	-48.93	5.50	14.23	Horizontal	-40.2	-25.00	27.2	180
7	17972.5	-46.25	5.70	14.15	Horizontal	-37.8	-25.00	24.8	270
8	20540.0	-43.66	6.30	13.76	Horizontal	-36.2	-25.00	23.2	135
9	23107.5	-43.05	6.80	14.05	Horizontal	-35.8	-25.00	22.8	180
10	25675.0	-43.54	6.90	14.84	Horizontal	-35.6	-25.00	22.6	225

Note: 1.The other Spurious RF Radiated emissions level is no more than noise floor.
2. The worst emission was found in the antenna is Horizontal position.

LTE Band 7 QPSK 10MHz CH-Low, RB 1

Harmonic	Frequency (MHz)	SG (dBm)	Cable Loss (dB)	Gain (dBi)	Antenna Polarization	EIRP Level (dBm)	Limit (dBm)	Margin (dB)	Azimuth (deg)
2	5010.0	-55.65	2.00	9.15	Horizontal	-48.5	-25.00	35.5	225
3	7515.0	-52.35	2.50	11.35	Horizontal	-43.5	-25.00	30.5	45
4	10020.0	-49.15	4.20	12.05	Horizontal	-41.3	-25.00	28.3	180
5	12525.0	-47.45	5.20	12.85	Horizontal	-39.8	-25.00	26.8	270
6	15030.0	-47.33	5.50	14.23	Horizontal	-38.6	-25.00	25.6	135
7	17535.0	-46.65	5.70	14.15	Horizontal	-38.2	-25.00	25.2	135
8	20040.0	-44.56	6.30	13.76	Horizontal	-37.1	-25.00	24.1	0
9	22545.0	-43.95	6.80	14.05	Horizontal	-36.7	-25.00	23.7	90
10	25050.0	-43.84	6.90	14.84	Horizontal	-35.9	-25.00	22.9	180

Note: 1.The other Spurious RF Radiated emissions level is no more than noise floor.
2. The worst emission was found in the antenna is Horizontal position.

LTE Band 7 QPSK 10MHz CH-Middle, RB 1

Harmonic	Frequency (MHz)	SG (dBm)	Cable Loss (dB)	Gain (dBi)	Antenna Polarization	EIRP Level (dBm)	Limit (dBm)	Margin (dB)	Azimuth (deg)
2	5070.0	-54.45	2.00	9.15	Horizontal	-47.3	-25.00	34.3	45
3	7605.0	-52.05	2.50	11.35	Horizontal	-43.2	-25.00	30.2	180
4	10140.0	-48.25	4.20	12.05	Horizontal	-40.4	-25.00	27.4	45
5	12675.0	-47.15	5.20	12.85	Horizontal	-39.5	-25.00	26.5	135
6	15210.0	-45.83	5.50	14.23	Horizontal	-37.1	-25.00	24.1	180
7	17745.0	-44.65	5.70	14.15	Horizontal	-36.2	-25.00	23.2	135
8	20280.0	-43.16	6.30	13.76	Horizontal	-35.7	-25.00	22.7	225
9	22815.0	-41.55	6.80	14.05	Horizontal	-34.3	-25.00	21.3	90
10	25350.0	-41.04	6.90	14.84	Horizontal	-33.1	-25.00	20.1	315

Note: 1.The other Spurious RF Radiated emissions level is no more than noise floor.

2. The worst emission was found in the antenna is Horizontal position.

LTE Band 7 QPSK 10MHz CH-High, RB 1

Harmonic	Frequency (MHz)	SG (dBm)	Cable Loss (dB)	Gain (dBi)	Antenna Polarization	EIRP Level (dBm)	Limit (dBm)	Margin (dB)	Azimuth (deg)
2	5130.0	-54.65	2.00	10.15	Horizontal	-46.5	-25.00	33.5	45
3	7695.0	-51.55	2.50	11.35	Horizontal	-42.7	-25.00	29.7	180
4	10260.0	-48.65	4.20	12.05	Horizontal	-40.8	-25.00	27.8	225
5	12825.0	-46.75	5.20	14.85	Horizontal	-37.1	-25.00	24.1	45
6	15390.0	-47.53	5.50	13.23	Horizontal	-39.8	-25.00	26.8	90
7	17955.0	-42.45	5.70	12.15	Horizontal	-36.0	-25.00	23.0	180
8	20520.0	-43.56	6.30	13.76	Horizontal	-36.1	-25.00	23.1	270
9	23085.0	-42.45	6.80	14.05	Horizontal	-35.2	-25.00	22.2	180
10	25650.0	-41.94	6.90	14.84	Horizontal	-34.0	-25.00	21.0	270

Note: 1.The other Spurious RF Radiated emissions level is no more than noise floor.

2. The worst emission was found in the antenna is Horizontal position.



LTE Band 7 QPSK 15MHz CH-Low, RB 1

Harmonic	Frequency (MHz)	SG (dBm)	Cable Loss (dB)	Gain (dBi)	Antenna Polarization	EIRP Level (dBm)	Limit (dBm)	Margin (dB)	Azimuth (deg)
2	5015.0	-56.75	2.00	10.15	Horizontal	-48.6	-25.00	35.6	270
3	7522.5	-51.65	2.50	11.35	Horizontal	-42.8	-25.00	29.8	135
4	10030.0	-48.75	4.20	12.05	Horizontal	-40.9	-25.00	27.9	180
5	12537.5	-49.55	5.20	14.85	Horizontal	-39.9	-25.00	26.9	225
6	15045.0	-47.03	5.50	13.23	Horizontal	-39.3	-25.00	26.3	45
7	17552.5	-44.35	5.70	12.15	Horizontal	-37.9	-25.00	24.9	90
8	20060.0	-43.96	6.30	13.76	Horizontal	-36.5	-25.00	23.5	180
9	22567.5	-42.55	6.80	14.05	Horizontal	-35.3	-25.00	22.3	270
10	25075.0	-42.14	6.90	14.84	Horizontal	-34.2	-25.00	21.2	135

Note: 1.The other Spurious RF Radiated emissions level is no more than noise floor.
2. The worst emission was found in the antenna is Horizontal position.

LTE Band 7 QPSK 15MHz CH-Middle, RB 1

Harmonic	Frequency (MHz)	SG (dBm)	Cable Loss (dB)	Gain (dBi)	Antenna Polarization	EIRP Level (dBm)	Limit (dBm)	Margin (dB)	Azimuth (deg)
2	5070.0	-55.55	2.00	10.15	Horizontal	-47.4	-25.00	34.4	180
3	7605.0	-51.55	2.50	11.35	Horizontal	-42.7	-25.00	29.7	270
4	10140.0	-48.15	4.20	12.05	Horizontal	-40.3	-25.00	27.3	135
5	12675.0	-48.85	5.20	14.85	Horizontal	-39.2	-25.00	26.2	225
6	15210.0	-45.23	5.50	13.23	Horizontal	-37.5	-25.00	24.5	135
7	17745.0	-43.35	5.70	12.15	Horizontal	-36.9	-25.00	23.9	18
8	20280.0	-43.36	6.30	13.76	Horizontal	-35.9	-25.00	22.9	180
9	22815.0	-41.65	6.80	14.05	Horizontal	-34.4	-25.00	21.4	270
10	25350.0	-41.64	6.90	14.84	Horizontal	-33.7	-25.00	20.7	45

Note: 1.The other Spurious RF Radiated emissions level is no more than noise floor.
2. The worst emission was found in the antenna is Horizontal position.



LTE Band 7 QPSK 15MHz CH-High, RB 1

Harmonic	Frequency (MHz)	SG (dBm)	Cable Loss (dB)	Gain (dBi)	Antenna Polarization	EIRP Level (dBm)	Limit (dBm)	Margin (dB)	Azimuth (deg)
2	5125.0	-54.55	2.00	10.15	Horizontal	-46.4	-25.00	33.4	270
3	7687.5	-51.65	2.50	11.35	Horizontal	-42.8	-25.00	29.8	135
4	10250.0	-47.75	4.20	12.05	Horizontal	-39.9	-25.00	26.9	45
5	12812.5	-47.95	5.20	14.85	Horizontal	-38.3	-25.00	25.3	270
6	15375.0	-45.83	5.50	13.23	Horizontal	-38.1	-25.00	25.1	180
7	17937.5	-43.95	5.70	12.15	Horizontal	-37.5	-25.00	24.5	270
8	20500.0	-44.26	6.30	13.76	Horizontal	-36.8	-25.00	23.8	135
9	23062.5	-43.15	6.80	14.05	Horizontal	-35.9	-25.00	22.9	180
10	25625.0	-42.54	6.90	14.84	Horizontal	-34.6	-25.00	21.6	270

Note: 1.The other Spurious RF Radiated emissions level is no more than noise floor.

2. The worst emission was found in the antenna is Horizontal position.

LTE Band 7 QPSK 20MHz CH-Low, RB 1

Harmonic	Frequency (MHz)	SG (dBm)	Cable Loss (dB)	Gain (dBi)	Antenna Polarization	EIRP Level (dBm)	Limit (dBm)	Margin (dB)	Azimuth (deg)
2	5020.0	-54.15	2.00	10.15	Horizontal	-46.0	-25.00	33.0	270
3	7530.0	-52.55	2.50	11.35	Horizontal	-43.7	-25.00	30.7	180
4	10040.0	-47.65	4.20	12.05	Horizontal	-39.8	-25.00	26.8	270
5	12550.0	-50.35	5.20	14.85	Horizontal	-40.7	-25.00	27.7	135
6	15060.0	-45.83	5.50	13.23	Horizontal	-38.1	-25.00	25.1	180
7	17570.0	-43.75	5.70	12.15	Horizontal	-37.3	-25.00	24.3	270
8	20080.0	-43.96	6.30	13.76	Horizontal	-36.5	-25.00	23.5	135
9	22590.0	-43.05	6.80	14.05	Horizontal	-35.8	-25.00	22.8	45
10	25100.0	-42.84	6.90	14.84	Horizontal	-34.9	-25.00	21.9	270

Note: 1.The other Spurious RF Radiated emissions level is no more than noise floor.

2. The worst emission was found in the antenna is Horizontal position.

LTE Band 7 QPSK 20MHz CH-Middle, RB 1

Harmonic	Frequency (MHz)	SG (dBm)	Cable Loss (dB)	Gain (dBi)	Antenna Polarization	EIRP Level (dBm)	Limit (dBm)	Margin (dB)	Azimuth (deg)
2	5070.0	-55.65	2.00	10.15	Horizontal	-47.5	-25.00	34.5	270
3	7605.0	-51.35	2.50	11.35	Horizontal	-42.5	-25.00	29.5	135
4	10140.0	-48.35	4.20	12.05	Horizontal	-40.5	-25.00	27.5	45
5	12675.0	-50.25	5.20	14.85	Horizontal	-40.6	-25.00	27.6	270
6	15210.0	-44.93	5.50	13.23	Horizontal	-37.2	-25.00	24.2	180
7	17745.0	-43.85	5.70	12.15	Horizontal	-37.4	-25.00	24.4	270
8	20280.0	-43.56	6.30	13.76	Horizontal	-36.1	-25.00	23.1	135
9	22815.0	-42.75	6.80	14.05	Horizontal	-35.5	-25.00	22.5	45
10	25350.0	-42.64	6.90	14.84	Horizontal	-34.7	-25.00	21.7	180

Note: 1.The other Spurious RF Radiated emissions level is no more than noise floor.

2. The worst emission was found in the antenna is Horizontal position.

LTE Band 7 QPSK 20MHz CH-High, RB 1

Harmonic	Frequency (MHz)	SG (dBm)	Cable Loss (dB)	Gain (dBi)	Antenna Polarization	EIRP Level (dBm)	Limit (dBm)	Margin (dB)	Azimuth (deg)
2	5120.0	-55.05	2.00	10.15	Horizontal	-46.9	-25.00	33.9	45
3	7680.0	-52.35	2.50	11.35	Horizontal	-43.5	-25.00	30.5	180
4	10240.0	-47.85	4.20	12.05	Horizontal	-40.0	-25.00	27.0	270
5	12800.0	-47.35	5.20	14.85	Horizontal	-37.7	-25.00	24.7	135
6	15360.0	-46.83	5.50	13.23	Horizontal	-39.1	-25.00	26.1	45
7	17920.0	-43.65	5.70	12.15	Horizontal	-37.2	-25.00	24.2	270
8	20480.0	-43.86	6.30	13.76	Horizontal	-36.4	-25.00	23.4	180
9	23040.0	-42.95	6.80	14.05	Horizontal	-35.7	-25.00	22.7	270
10	25600.0	-42.84	6.90	14.84	Horizontal	-34.9	-25.00	21.9	135

Note: 1.The other Spurious RF Radiated emissions level is no more than noise floor.

2. The worst emission was found in the antenna is Horizontal position.

LTE Band 12 QPSK 1.4MHz CH-Low, RB 1

Harmonic	Frequency (MHz)	SG (dBm)	Cable Loss (dB)	Gain (dBi)	Antenna Polarization	ERP Level (dBm)	Limit (dBm)	Margin (dB)	Azimuth (deg)
2	1399.40	-36.70	2.00	10.15	Horizontal	-30.7	-13.00	17.69	45
3	2099.10	-39.10	2.50	11.35	Horizontal	-32.4	-13.00	19.44	270
4	2798.80	-43.80	4.20	10.85	Horizontal	-39.3	-13.00	26.33	45
5	3498.50	-51.40	5.20	11.35	Horizontal	-47.4	-13.00	34.38	180
6	4198.20	-49.80	5.50	11.95	Horizontal	-45.5	-13.00	32.55	270
7	4897.90	-54.80	5.70	13.55	Horizontal	-49.1	-13.00	36.10	135
8	5597.60	-53.10	6.30	13.75	Horizontal	-47.8	-13.00	34.80	45
9	6297.30	-51.80	6.80	13.85	Horizontal	-46.9	-13.00	33.90	270
10	6997.00	-51.10	6.90	14.25	Horizontal	-45.9	-13.00	32.90	180

Note: 1.The other Spurious RF Radiated emissions level is no more than noise floor.
 2. The worst emission was found in the antenna is Horizontal position.

LTE Band 12 QPSK 1.4MHz CH-Middle, RB 1

Harmonic	Frequency (MHz)	SG (dBm)	Cable Loss (dB)	Gain (dBi)	Antenna Polarization	ERP Level (dBm)	Limit (dBm)	Margin (dB)	Azimuth (deg)
2	1415.00	-31.40	2.00	10.75	Horizontal	-24.8	-13.00	11.84	270
3	2122.50	-37.89	2.51	11.05	Horizontal	-31.5	-13.00	18.52	180
4	2830.00	-47.20	4.20	11.15	Horizontal	-42.4	-13.00	29.44	270
5	3537.50	-55.70	5.20	11.15	Horizontal	-51.9	-13.00	38.90	270
6	4245.00	-50.40	5.50	11.95	Horizontal	-46.1	-13.00	33.06	270
7	4952.50	-54.10	5.70	13.55	Horizontal	-48.4	-13.00	35.40	135
8	5660.00	-53.50	6.30	13.75	Horizontal	-48.2	-13.00	35.20	45
9	6367.50	-50.50	6.80	13.85	Horizontal	-45.6	-13.00	32.60	270
10	7075.00	-48.70	6.90	14.25	Horizontal	-43.5	-13.00	30.50	180

Note: 1.The other Spurious RF Radiated emissions level is no more than noise floor.
 2. The worst emission was found in the antenna is Horizontal position.



LTE Band 12 QPSK 1.4MHz CH-High, RB 1

Harmonic	Frequency (MHz)	SG (dBm)	Cable Loss (dB)	Gain (dBi)	Antenna Polarization	ERP Level (dBm)	Limit (dBm)	Margin (dB)	Azimuth (deg)
2	1430.60	-25.90	2.00	10.15	Horizontal	-19.9	-13.00	6.91	135
3	2145.90	-37.29	2.51	11.05	Horizontal	-30.9	-13.00	17.86	45
4	2861.20	-42.70	4.20	11.15	Horizontal	-37.9	-13.00	24.88	180
5	3576.50	-56.40	5.20	11.15	Horizontal	-52.6	-13.00	39.60	270
6	4291.80	-53.60	5.50	11.95	Horizontal	-49.3	-13.00	36.30	135
7	5007.10	-52.70	5.70	13.55	Horizontal	-47.0	-13.00	34.00	180
8	5722.40	-53.10	6.30	13.75	Horizontal	-47.8	-13.00	34.80	270
9	6437.70	-50.80	6.80	13.85	Horizontal	-45.9	-13.00	32.90	135
10	7153.00	-48.50	6.90	14.25	Horizontal	-43.3	-13.00	30.30	45

Note: 1.The other Spurious RF Radiated emissions level is no more than noise floor.

2. The worst emission was found in the antenna is Horizontal position.

LTE Band 12 QPSK 3MHz CH-Low, RB 1

Harmonic	Frequency (MHz)	SG (dBm)	Cable Loss (dB)	Gain (dBi)	Antenna Polarization	ERP Level (dBm)	Limit (dBm)	Margin (dB)	Azimuth (deg)
2	1401.00	-36.90	2.00	10.15	Horizontal	-30.9	-13.00	17.94	45
3	2101.50	-39.39	2.51	11.35	Horizontal	-32.7	-13.00	19.73	270
4	2802.00	-43.40	4.20	10.85	Horizontal	-38.9	-13.00	25.91	180
5	3502.50	-54.75	5.20	11.35	Horizontal	-50.75	-13.00	37.75	0
6	4203.00	-52.00	5.50	11.95	Horizontal	-47.7	-13.00	34.66	270
7	4903.50	-51.00	5.70	13.55	Horizontal	-45.3	-13.00	32.32	180
8	5604.00	-55.60	6.30	13.75	Horizontal	-50.3	-13.00	37.30	270
9	6304.50	-53.30	6.80	13.85	Horizontal	-48.4	-13.00	35.40	135
10	7005.00	-51.60	6.90	14.25	Horizontal	-46.4	-13.00	33.40	90

Note: 1.The other Spurious RF Radiated emissions level is no more than noise floor.

2. The worst emission was found in the antenna is Horizontal position.



LTE Band 12 QPSK 3MHz CH-Middle, RB 1

Harmonic	Frequency (MHz)	SG (dBm)	Cable Loss (dB)	Gain (dBi)	Antenna Polarization	ERP Level (dBm)	Limit (dBm)	Margin (dB)	Azimuth (deg)
2	1415.00	-32.20	2.00	10.75	Horizontal	-25.6	-13.00	12.63	270
3	2122.50	-38.29	2.51	11.05	Horizontal	-31.9	-13.00	18.87	135
4	2830.00	-46.00	4.20	11.15	Horizontal	-41.2	-13.00	28.22	45
5	3537.50	-49.80	5.20	11.15	Horizontal	-46.0	-13.00	33.00	90
6	4245.00	-54.40	5.50	11.95	Horizontal	-50.1	-13.00	37.10	135
7	4952.50	-53.30	5.70	13.55	Horizontal	-47.6	-13.00	34.60	225
8	5660.00	-53.40	6.30	13.75	Horizontal	-48.1	-13.00	35.10	225
9	6367.50	-50.30	6.80	13.85	Horizontal	-45.4	-13.00	32.40	180
10	7075.00	-48.60	6.90	14.25	Horizontal	-43.4	-13.00	30.40	45

Note: 1. The other Spurious RF Radiated emissions level is no more than noise floor.
2. The worst emission was found in the antenna is Horizontal position.

LTE Band 12 QPSK 3MHz CH-High, RB 1

Harmonic	Frequency (MHz)	SG (dBm)	Cable Loss (dB)	Gain (dBi)	Antenna Polarization	ERP Level (dBm)	Limit (dBm)	Margin (dB)	Azimuth (deg)
2	1429.00	-26.90	2.00	10.15	Horizontal	-20.9	-13.00	7.90	180
3	2143.50	-37.79	2.51	11.05	Horizontal	-31.4	-13.00	18.39	45
4	2858.00	-44.70	4.20	11.15	Horizontal	-39.9	-13.00	26.87	180
5	3572.50	-55.80	5.20	11.15	Horizontal	-52.0	-13.00	39.00	225
6	4287.00	-49.10	5.50	11.95	Horizontal	-44.8	-13.00	31.85	180
7	5001.50	-52.50	5.70	13.55	Horizontal	-46.8	-13.00	33.80	45
8	5716.00	-53.10	6.30	13.75	Horizontal	-47.8	-13.00	34.80	315
9	6430.50	-50.60	6.80	13.85	Horizontal	-45.7	-13.00	32.70	270
10	7145.00	-48.30	6.90	14.25	Horizontal	-43.1	-13.00	30.10	315

Note: 1. The other Spurious RF Radiated emissions level is no more than noise floor.
2. The worst emission was found in the antenna is Horizontal position.



LTE Band 12 QPSK 5MHz CH-Low, RB 1

Harmonic	Frequency (MHz)	SG (dBm)	Cable Loss (dB)	Gain (dBi)	Antenna Polarization	ERP Level (dBm)	Limit (dBm)	Margin (dB)	Azimuth (deg)
2	1403.00	-34.70	2.00	10.15	Horizontal	-28.7	-13.00	15.65	45
3	2104.50	-33.80	2.50	11.35	Horizontal	-27.1	-13.00	14.06	270
4	2806.00	-44.00	4.20	10.85	Horizontal	-39.5	-13.00	26.53	180
5	3507.50	-50.90	5.20	11.35	Horizontal	-46.9	-13.00	33.91	270
6	4209.00	-48.80	5.50	11.95	Horizontal	-44.5	-13.00	31.52	135
7	4910.50	-54.10	5.70	13.55	Horizontal	-48.4	-13.00	35.40	90
8	5612.00	-51.50	6.30	13.75	Horizontal	-46.2	-13.00	33.20	225
9	6313.50	-51.20	6.80	13.85	Horizontal	-46.3	-13.00	33.30	180
10	7015.00	-50.50	6.90	14.25	Horizontal	-45.3	-13.00	32.30	45

Note: 1. The other Spurious RF Radiated emissions level is no more than noise floor.
2. The worst emission was found in the antenna is Horizontal position.

LTE Band 12 QPSK 5MHz CH-Middle, RB 1

Harmonic	Frequency (MHz)	SG (dBm)	Cable Loss (dB)	Gain (dBi)	Antenna Polarization	ERP Level (dBm)	Limit (dBm)	Margin (dB)	Azimuth (deg)
2	1415.00	-35.70	2.00	10.75	Horizontal	-29.1	-13.00	16.07	270
3	2122.50	-34.89	2.51	11.05	Horizontal	-28.5	-13.00	15.53	135
4	2830.00	-45.40	4.20	11.15	Horizontal	-40.6	-13.00	27.63	45
5	3537.50	-50.60	5.20	11.15	Horizontal	-46.8	-13.00	33.80	225
6	4245.00	-50.10	5.50	11.95	Horizontal	-45.8	-13.00	32.83	180
7	4952.50	-55.40	5.70	13.55	Horizontal	-49.7	-13.00	36.70	45
8	5660.00	-53.60	6.30	13.75	Horizontal	-48.3	-13.00	35.30	315
9	6367.50	-47.90	6.80	13.85	Horizontal	-43.0	-13.00	30.00	270
10	7075.00	-48.20	6.90	14.25	Horizontal	-43.0	-13.00	30.00	135

Note: 1. The other Spurious RF Radiated emissions level is no more than noise floor.
2. The worst emission was found in the antenna is Horizontal position.



LTE Band 12 QPSK 5MHz CH-High, RB 1

Harmonic	Frequency (MHz)	SG (dBm)	Cable Loss (dB)	Gain (dBi)	Antenna Polarization	ERP Level (dBm)	Limit (dBm)	Margin (dB)	Azimuth (deg)
2	1427.00	-27.30	2.00	10.15	Horizontal	-21.3	-13.00	8.29	180
3	2140.50	-36.89	2.51	11.05	Horizontal	-30.5	-13.00	17.46	45
4	2854.00	-45.50	4.20	11.15	Horizontal	-40.7	-13.00	27.74	180
5	3567.50	-51.10	5.20	11.15	Horizontal	-47.3	-13.00	34.33	90
6	4281.00	-50.40	5.50	11.95	Horizontal	-46.1	-13.00	33.14	225
7	4994.50	-51.50	5.70	13.55	Horizontal	-45.8	-13.00	32.80	180
8	5708.00	-53.00	6.30	13.75	Horizontal	-47.7	-13.00	34.70	45
9	6421.50	-51.30	6.80	13.85	Horizontal	-46.4	-13.00	33.40	225
10	7135.00	-48.90	6.90	14.25	Horizontal	-43.7	-13.00	30.70	180

Note: 1.The other Spurious RF Radiated emissions level is no more than noise floor.
2. The worst emission was found in the antenna is Horizontal position.

LTE Band 12 QPSK 10MHz CH-Low, RB 1

Harmonic	Frequency (MHz)	SG (dBm)	Cable Loss (dB)	Gain (dBi)	Antenna Polarization	ERP Level (dBm)	Limit (dBm)	Margin (dB)	Azimuth (deg)
2	1408.00	-34.80	2.00	10.15	Horizontal	-28.8	-13.00	15.77	270
3	2112.00	-33.99	2.51	11.35	Horizontal	-27.3	-13.00	14.29	135
4	2816.00	-44.00	4.20	10.85	Horizontal	-39.5	-13.00	26.55	45
5	3520.00	-50.20	5.20	11.35	Horizontal	-46.2	-13.00	33.20	135
6	4224.00	-47.80	5.50	11.95	Horizontal	-43.5	-13.00	30.55	0
7	4928.00	-55.10	5.70	13.55	Horizontal	-49.4	-13.00	36.40	90
8	5632.00	-53.70	6.30	13.75	Horizontal	-48.4	-13.00	35.40	135
9	6336.00	-51.70	6.80	13.85	Horizontal	-46.8	-13.00	33.80	270
10	7040.00	-48.80	6.90	14.25	Horizontal	-43.6	-13.00	30.60	225

Note: 1.The other Spurious RF Radiated emissions level is no more than noise floor.
2. The worst emission was found in the antenna is Horizontal position.

LTE Band 12 QPSK 10MHz CH-Middle, RB 1

Harmonic	Frequency (MHz)	SG (dBm)	Cable Loss (dB)	Gain (dBi)	Antenna Polarization	ERP Level (dBm)	Limit (dBm)	Margin (dB)	Azimuth (deg)
2	1415.00	-37.40	2.00	10.75	Horizontal	-30.8	-13.00	17.82	270
3	2122.50	-34.59	2.51	11.05	Horizontal	-28.2	-13.00	15.18	180
4	2830.00	-45.00	4.20	11.15	Horizontal	-40.2	-13.00	27.21	270
5	3537.50	-50.70	5.20	11.15	Horizontal	-46.9	-13.00	33.86	135
6	4245.00	-49.40	5.50	11.95	Horizontal	-45.1	-13.00	32.15	225
7	4952.50	-55.10	5.70	13.55	Horizontal	-49.4	-13.00	36.40	135
8	5660.00	-53.20	6.30	13.75	Horizontal	-47.9	-13.00	34.90	0
9	6367.50	-50.20	6.80	13.85	Horizontal	-45.3	-13.00	32.30	45
10	7075.00	-49.60	6.90	14.25	Horizontal	-44.4	-13.00	31.40	135

Note: 1.The other Spurious RF Radiated emissions level is no more than noise floor.

2. The worst emission was found in the antenna is Horizontal position.

LTE Band 12 QPSK 10MHz CH-High, RB 1

Harmonic	Frequency (MHz)	SG (dBm)	Cable Loss (dB)	Gain (dBi)	Antenna Polarization	ERP Level (dBm)	Limit (dBm)	Margin (dB)	Azimuth (deg)
2	1422.00	-32.90	2.00	10.15	Horizontal	-26.9	-13.00	13.88	135
3	2133.00	-34.89	2.51	11.05	Horizontal	-28.5	-13.00	15.54	45
4	2844.00	-45.80	4.20	11.15	Horizontal	-41.0	-13.00	27.99	180
5	3555.00	-50.70	5.20	11.15	Horizontal	-46.9	-13.00	33.86	0
6	4266.00	-49.60	5.50	11.95	Horizontal	-45.3	-13.00	32.27	90
7	4977.00	-54.40	5.70	13.55	Horizontal	-48.7	-13.00	35.70	135
8	5688.00	-52.80	6.30	13.75	Horizontal	-47.5	-13.00	34.50	270
9	6399.00	-52.00	6.80	13.85	Horizontal	-47.1	-13.00	34.10	225
10	7110.00	-49.10	6.90	14.25	Horizontal	-43.9	-13.00	30.90	135

Note: 1.The other Spurious RF Radiated emissions level is no more than noise floor.

2. The worst emission was found in the antenna is Horizontal position.

LTE Band 66 QPSK 1.4MHz CH-Low, RB 1

Harmonic	Frequency (MHz)	SG (dBm)	Cable Loss (dB)	Gain (dBi)	Antenna Polarization	EIRP Level (dBm)	Limit (dBm)	Margin (dB)	Azimuth (deg)
2	3421.4	-56.15	2.6	10.15	Horizontal	-48.6	-13.00	35.6	315
3	5131.1	-56.65	2.4	11.35	Horizontal	-47.7	-13.00	34.7	270
4	6842.8	-51.15	4.5	10.85	Horizontal	-44.8	-13.00	31.8	135
5	8553.5	-78.35	5.1	11.35	Horizontal	-72.1	-13.00	59.1	225
6	10264.2	-47.85	5.3	11.95	Horizontal	-41.2	-13.00	28.2	180
7	11974.9	-47.25	5.5	13.55	Horizontal	-39.2	-13.00	26.2	45
8	13685.6	-44.75	6.3	13.75	Horizontal	-37.3	-13.00	24.3	315
9	15396.3	-46.75	6.7	13.85	Horizontal	-39.6	-13.00	26.6	270
10	17107.0	-43.55	6.8	14.25	Horizontal	-36.1	-13.00	23.1	135

Note: 1.The other Spurious RF Radiated emissions level is no more than noise floor.
2. The worst emission was found in the antenna is Horizontal position.

LTE Band 66 QPSK 1.4MHz CH-Middle, RB 1

Harmonic	Frequency (MHz)	SG (dBm)	Cable Loss (dB)	Gain (dBi)	Antenna Polarization	EIRP Level (dBm)	Limit (dBm)	Margin (dB)	Azimuth (deg)
2	3464.3	-54.85	2.6	10.75	Horizontal	-46.7	-13.00	33.7	90
3	5197.5	-56.35	2.4	11.05	Horizontal	-47.7	-13.00	34.7	225
4	6930.0	-50.05	4.5	11.15	Horizontal	-43.4	-13.00	30.4	180
5	8662.5	-47.65	5.1	11.35	Horizontal	-41.4	-13.00	28.4	225
6	10395.0	-46.25	5.3	11.95	Horizontal	-39.6	-13.00	26.6	180
7	12127.5	-48.05	5.5	13.55	Horizontal	-40.0	-13.00	27.0	45
8	13860.0	-43.75	6.3	13.75	Horizontal	-36.3	-13.00	23.3	270
9	15592.5	-46.85	6.7	13.85	Horizontal	-39.7	-13.00	26.7	90
10	17325.0	-42.75	6.8	14.25	Horizontal	-35.3	-13.00	22.3	180

Note: 1.The other Spurious RF Radiated emissions level is no more than noise floor.
2. The worst emission was found in the antenna is Horizontal position.



LTE Band 66 QPSK 1.4MHz CH-High, RB 1

Harmonic	Frequency (MHz)	SG (dBm)	Cable Loss (dB)	Gain (dBi)	Antenna Polarization	EIRP Level (dBm)	Limit (dBm)	Margin (dB)	Azimuth (deg)
2	3507.8	-55.05	2.6	10.15	Horizontal	-47.5	-13.00	34.5	315
3	5261.6	-57.05	2.4	11.05	Horizontal	-48.4	-13.00	35.4	270
4	7017.2	38.35	4.5	11.15	Horizontal	-45.0	-13.00	32.0	135
5	8771.5	-47.95	5.1	11.35	Horizontal	-41.7	-13.00	28.7	225
6	10525.8	-45.75	5.3	11.95	Horizontal	-39.1	-13.00	26.1	180
7	12280.1	-47.65	5.5	13.55	Horizontal	-39.6	-13.00	26.6	45
8	14034.4	-44.05	6.3	13.75	Horizontal	-36.6	-13.00	23.6	315
9	15788.7	-45.55	6.7	13.85	Horizontal	-38.4	-13.00	25.4	270
10	17543.0	-44.55	6.8	14.25	Horizontal	-37.1	-13.00	24.1	135

Note: 1.The other Spurious RF Radiated emissions level is no more than noise floor.

2. The worst emission was found in the antenna is Horizontal position.

LTE Band 66 QPSK 3MHz CH-Low, RB 1

Harmonic	Frequency (MHz)	SG (dBm)	Cable Loss (dB)	Gain (dBi)	Antenna Polarization	EIRP Level (dBm)	Limit (dBm)	Margin (dB)	Azimuth (deg)
2	3423.0	-56.15	2.6	10.15	Horizontal	-48.6	-13.00	35.6	90
3	5134.5	-57.15	2.4	11.35	Horizontal	-48.2	-13.00	35.2	225
4	6846.0	-51.55	4.5	10.85	Horizontal	-45.2	-13.00	32.2	315
5	8557.5	-48.25	5.1	11.35	Horizontal	-42.0	-13.00	29.0	270
6	10269.0	-47.95	5.3	11.95	Horizontal	-41.3	-13.00	28.3	135
7	11980.5	-47.55	5.5	13.55	Horizontal	-39.5	-13.00	26.5	225
8	13692.0	-44.95	6.3	13.75	Horizontal	-37.5	-13.00	24.5	180
9	15403.5	-46.75	6.7	13.85	Horizontal	-39.6	-13.00	26.6	45
10	17115.0	-45.25	6.8	14.25	Horizontal	-37.8	-13.00	24.8	315

Note: 1.The other Spurious RF Radiated emissions level is no more than noise floor.

2. The worst emission was found in the antenna is Horizontal position.



LTE Band 66 QPSK 3MHz CH-Middle, RB 1

Harmonic	Frequency (MHz)	SG (dBm)	Cable Loss (dB)	Gain (dBi)	Antenna Polarization	EIRP Level (dBm)	Limit (dBm)	Margin (dB)	Azimuth (deg)
2	3465.0	-55.65	2.6	10.75	Horizontal	-47.5	-13.00	34.5	270
3	5197.5	-55.75	2.4	11.05	Horizontal	-47.1	-13.00	34.1	135
4	6930.0	-51.65	4.5	11.15	Horizontal	-45.0	-13.00	32.0	90
5	8662.5	-47.35	5.1	11.35	Horizontal	-41.1	-13.00	28.1	225
6	10395.0	-47.15	5.3	11.95	Horizontal	-40.5	-13.00	27.5	180
7	12127.5	-46.85	5.5	13.55	Horizontal	-38.8	-13.00	25.8	225
8	13860.0	-44.85	6.3	13.75	Horizontal	-37.4	-13.00	24.4	180
9	15592.5	-47.85	6.7	13.85	Horizontal	-40.7	-13.00	27.7	45
10	17325.0	-44.25	6.8	14.25	Horizontal	-36.8	-13.00	23.8	315

Note: 1.The other Spurious RF Radiated emissions level is no more than noise floor.
2. The worst emission was found in the antenna is Horizontal position.

LTE Band 66 QPSK 3MHz CH-High, RB 1

Harmonic	Frequency (MHz)	SG (dBm)	Cable Loss (dB)	Gain (dBi)	Antenna Polarization	EIRP Level (dBm)	Limit (dBm)	Margin (dB)	Azimuth (deg)
2	3504.8	-55.95	2.6	10.15	Horizontal	-48.4	-13.00	35.4	45
3	5256.8	-58.65	2.4	11.05	Horizontal	-50.0	-13.00	37.0	315
4	7014.0	-52.55	4.5	11.15	Horizontal	-45.9	-13.00	32.9	90
5	8767.5	-48.65	5.1	11.35	Horizontal	-42.4	-13.00	29.4	180
6	10521.0	-46.55	5.3	11.95	Horizontal	-39.9	-13.00	26.9	225
7	12274.5	-48.05	5.5	13.55	Horizontal	-40.0	-13.00	27.0	90
8	14028.0	-44.15	6.3	13.75	Horizontal	-36.7	-13.00	23.7	270
9	15781.5	-46.25	6.7	13.85	Horizontal	-39.1	-13.00	26.1	135
10	17535.0	-44.55	6.8	14.25	Horizontal	-37.1	-13.00	24.1	270

Note: 1.The other Spurious RF Radiated emissions level is no more than noise floor.
2. The worst emission was found in the antenna is Horizontal position.



LTE Band 66 QPSK 5MHz CH-Low, RB 1

Harmonic	Frequency (MHz)	SG (dBm)	Cable Loss (dB)	Gain (dBi)	Antenna Polarization	EIRP Level (dBm)	Limit (dBm)	Margin (dB)	Azimuth (deg)
2	3425.0	-55.15	2.6	10.15	Horizontal	-47.6	-13.00	34.6	180
3	5131.1	-57.15	2.4	11.35	Horizontal	-48.2	-13.00	35.2	270
4	6850.0	-49.85	4.5	10.85	Horizontal	-43.5	-13.00	30.5	45
5	8562.5	-49.05	5.1	11.35	Horizontal	-42.8	-13.00	29.8	225
6	10275.0	-47.55	5.3	11.95	Horizontal	-40.9	-13.00	27.9	315
7	11987.5	-47.05	5.5	13.55	Horizontal	-39.0	-13.00	26.0	90
8	13700.0	-45.65	6.3	13.75	Horizontal	-38.2	-13.00	25.2	45
9	15412.5	-46.75	6.7	13.85	Horizontal	-39.6	-13.00	26.6	315
10	17125.0	-44.45	6.8	14.25	Horizontal	-37.0	-13.00	24.0	180

Note: 1.The other Spurious RF Radiated emissions level is no more than noise floor.
2. The worst emission was found in the antenna is Horizontal position.

LTE Band 66 QPSK 5MHz CH-Middle, RB 1

Harmonic	Frequency (MHz)	SG (dBm)	Cable Loss (dB)	Gain (dBi)	Antenna Polarization	EIRP Level (dBm)	Limit (dBm)	Margin (dB)	Azimuth (deg)
2	3460.5	-54.65	2.6	10.75	Horizontal	-46.5	-13.00	33.5	45
3	5191.5	-55.25	2.4	11.05	Horizontal	-46.6	-13.00	33.6	315
4	6930.0	-52.05	4.5	11.15	Horizontal	-45.4	-13.00	32.4	90
5	8662.5	-47.15	5.1	11.35	Horizontal	-40.9	-13.00	27.9	180
6	10395.0	-46.85	5.3	11.95	Horizontal	-40.2	-13.00	27.2	270
7	12127.5	-47.05	5.5	13.55	Horizontal	-39.0	-13.00	26.0	315
8	13860.0	-44.45	6.3	13.75	Horizontal	-37.0	-13.00	24.0	225
9	15592.5	-47.35	6.7	13.85	Horizontal	-40.2	-13.00	27.2	45
10	17325.0	-43.75	6.8	14.25	Horizontal	-36.3	-13.00	23.3	180

Note: 1.The other Spurious RF Radiated emissions level is no more than noise floor.
2. The worst emission was found in the antenna is Horizontal position.



LTE Band 66 QPSK 5MHz CH-High, RB 1

Harmonic	Frequency (MHz)	SG (dBm)	Cable Loss (dB)	Gain (dBi)	Antenna Polarization	EIRP Level (dBm)	Limit (dBm)	Margin (dB)	Azimuth (deg)
2	3500.6	-55.35	2.6	10.15	Horizontal	-47.8	-13.00	34.8	90
3	5250.8	-58.25	2.4	11.05	Horizontal	-49.6	-13.00	36.6	315
4	7010.0	-52.35	4.5	11.15	Horizontal	-45.7	-13.00	32.7	270
5	8762.5	-48.55	5.1	11.35	Horizontal	-42.3	-13.00	29.3	45
6	10515.0	-46.55	5.3	11.95	Horizontal	-39.9	-13.00	26.9	180
7	12267.5	-46.85	5.5	13.55	Horizontal	-38.8	-13.00	25.8	90
8	14020.0	-44.25	6.3	13.75	Horizontal	-36.8	-13.00	23.8	225
9	15772.5	-45.55	6.7	13.85	Horizontal	-38.4	-13.00	25.4	270
10	17525.0	-44.75	6.8	14.25	Horizontal	-37.3	-13.00	24.3	315

Note: 1.The other Spurious RF Radiated emissions level is no more than noise floor.
2. The worst emission was found in the antenna is Horizontal position.

LTE Band 66 QPSK 10MHz CH-Low, RB 1

Harmonic	Frequency (MHz)	SG (dBm)	Cable Loss (dB)	Gain (dBi)	Antenna Polarization	EIRP Level (dBm)	Limit (dBm)	Margin (dB)	Azimuth (deg)
2	3420.8	-57.15	2.6	10.15	Horizontal	-49.6	-13.00	36.6	270
3	5131.9	-55.65	2.4	11.35	Horizontal	-46.7	-13.00	33.7	180
4	6860.0	-51.25	4.5	10.85	Horizontal	-44.9	-13.00	31.9	45
5	8575.0	-48.05	5.1	11.35	Horizontal	-41.8	-13.00	28.8	225
6	10290.0	-47.65	5.3	11.95	Horizontal	-41.0	-13.00	28.0	180
7	12005.0	-47.25	5.5	13.55	Horizontal	-39.2	-13.00	26.2	315
8	13720.0	-44.85	6.3	13.75	Horizontal	-37.4	-13.00	24.4	45
9	15435.0	-46.35	6.7	13.85	Horizontal	-39.2	-13.00	26.2	225
10	17150.0	-43.95	6.8	14.25	Horizontal	-36.5	-13.00	23.5	90

Note: 1.The other Spurious RF Radiated emissions level is no more than noise floor.
2. The worst emission was found in the antenna is Horizontal position.



LTE Band 66 QPSK 10MHz CH-Middle, RB 1

Harmonic	Frequency (MHz)	SG (dBm)	Cable Loss (dB)	Gain (dBi)	Antenna Polarization	EIRP Level (dBm)	Limit (dBm)	Margin (dB)	Azimuth (deg)
2	3456.0	-56.45	2.6	10.75	Horizontal	-48.3	-13.00	35.3	225
3	5184.4	-55.65	2.4	11.05	Horizontal	-47.0	-13.00	34.0	180
4	6930.0	-52.15	4.5	11.15	Horizontal	-45.5	-13.00	32.5	90
5	8662.5	-49.15	5.1	11.35	Horizontal	-42.9	-13.00	29.9	270
6	10395.0	-46.65	5.3	11.95	Horizontal	-40.0	-13.00	27.0	45
7	12127.5	-45.65	5.5	13.55	Horizontal	-37.6	-13.00	24.6	225
8	13860.0	-45.45	6.3	13.75	Horizontal	-38.0	-13.00	25.0	315
9	15592.5	-47.55	6.7	13.85	Horizontal	-40.4	-13.00	27.4	180
10	17325.0	-43.55	6.8	14.25	Horizontal	-36.1	-13.00	23.1	135

Note: 1.The other Spurious RF Radiated emissions level is no more than noise floor.
2. The worst emission was found in the antenna is Horizontal position.

LTE Band 66 QPSK 10MHz CH-High, RB 1

Harmonic	Frequency (MHz)	SG (dBm)	Cable Loss (dB)	Gain (dBi)	Antenna Polarization	EIRP Level (dBm)	Limit (dBm)	Margin (dB)	Azimuth (deg)
2	3490.9	-56.55	2.6	10.15	Horizontal	-49.0	-13.00	36.0	315
3	5236.9	-57.35	2.4	11.05	Horizontal	-48.7	-13.00	35.7	90
4	7000.0	-51.95	4.5	11.15	Horizontal	-45.3	-13.00	32.3	270
5	8750.0	-47.55	5.1	11.35	Horizontal	-41.3	-13.00	28.3	45
6	10500.0	-46.45	5.3	11.95	Horizontal	-39.8	-13.00	26.8	225
7	12250.0	-46.55	5.5	13.55	Horizontal	-38.5	-13.00	25.5	180
8	14000.0	-45.55	6.3	13.75	Horizontal	-38.1	-13.00	25.1	270
9	15750.0	-46.95	6.7	13.85	Horizontal	-39.8	-13.00	26.8	315
10	17500.0	-44.75	6.8	14.25	Horizontal	-37.3	-13.00	24.3	180

Note: 1.The other Spurious RF Radiated emissions level is no more than noise floor.
2. The worst emission was found in the antenna is Horizontal position.



LTE Band 66 QPSK 15MHz CH Low, RB 1

Harmonic	Frequency (MHz)	SG (dBm)	Cable Loss (dB)	Gain (dBi)	Antenna Polarization	EIRP Level (dBm)	Limit (dBm)	Margin (dB)	Azimuth (deg)
2	3448.1	-54.85	2.6	10.15	Horizontal	-47.3	-13.00	34.3	225
3	5132.6	-56.55	2.4	11.35	Horizontal	-47.6	-13.00	34.6	180
4	6870.0	-51.25	4.5	10.85	Horizontal	-44.9	-13.00	31.9	270
5	8587.5	-48.95	5.1	11.35	Horizontal	-42.7	-13.00	29.7	45
6	10305.0	-47.75	5.3	11.95	Horizontal	-41.1	-13.00	28.1	135
7	12022.5	-48.55	5.5	13.55	Horizontal	-40.5	-13.00	27.5	90
8	13740.0	-45.65	6.3	13.75	Horizontal	-38.2	-13.00	25.2	135
9	15457.5	-47.15	6.7	13.85	Horizontal	-40.0	-13.00	27.0	225
10	17175.0	-44.85	6.8	14.25	Horizontal	-37.4	-13.00	24.4	315

Note: 1.The other Spurious RF Radiated emissions level is no more than noise floor.
2. The worst emission was found in the antenna is Horizontal position.

LTE Band 66 QPSK 15MHz CH-Middle, RB 1

Harmonic	Frequency (MHz)	SG (dBm)	Cable Loss (dB)	Gain (dBi)	Antenna Polarization	EIRP Level (dBm)	Limit (dBm)	Margin (dB)	Azimuth (deg)
2	3478.1	-56.15	2.6	10.75	Horizontal	-48.0	-13.00	35.0	180
3	5217.8	-55.55	2.4	11.05	Horizontal	-46.9	-13.00	33.9	315
4	6930.0	-51.85	4.5	11.15	Horizontal	-45.2	-13.00	32.2	90
5	8662.5	-48.05	5.1	11.35	Horizontal	-41.8	-13.00	28.8	225
6	10395.0	-46.05	5.3	11.95	Horizontal	-39.4	-13.00	26.4	270
7	12127.5	-47.75	5.5	13.55	Horizontal	-39.7	-13.00	26.7	45
8	13860.0	-44.35	6.3	13.75	Horizontal	-36.9	-13.00	23.9	180
9	15592.5	-45.95	6.7	13.85	Horizontal	-38.8	-13.00	25.8	90
10	17325.0	-43.95	6.8	14.25	Horizontal	-36.5	-13.00	23.5	135

Note: 1.The other Spurious RF Radiated emissions level is no more than noise floor.
2. The worst emission was found in the antenna is Horizontal position.

LTE Band 66 QPSK 15MHz CH-High, RB 1

Harmonic	Frequency (MHz)	SG (dBm)	Cable Loss (dB)	Gain (dBi)	Antenna Polarization	EIRP Level (dBm)	Limit (dBm)	Margin (dB)	Azimuth (deg)
2	3508.1	-54.75	2.6	10.15	Horizontal	-47.2	-13.00	34.2	225
3	5262.8	-57.65	2.4	11.05	Horizontal	-49.0	-13.00	36.0	45
4	6990.0	-52.55	4.5	11.15	Horizontal	-45.9	-13.00	32.9	270
5	8737.5	-49.35	5.1	11.35	Horizontal	-43.1	-13.00	30.1	315
6	10485.0	-47.05	5.3	11.95	Horizontal	-40.4	-13.00	27.4	90
7	12232.5	-47.65	5.5	13.55	Horizontal	-39.6	-13.00	26.6	225
8	13980.0	-45.85	6.3	13.75	Horizontal	-38.4	-13.00	25.4	45
9	15727.5	-46.65	6.7	13.85	Horizontal	-39.5	-13.00	26.5	180
10	17475.0	-45.05	6.8	14.25	Horizontal	-37.6	-13.00	24.6	90

Note: 1.The other Spurious RF Radiated emissions level is no more than noise floor.

2. The worst emission was found in the antenna is Horizontal position.

LTE Band 66 QPSK 20MHz CH-Low, RB 1

Harmonic	Frequency (MHz)	SG (dBm)	Cable Loss (dB)	Gain (dBi)	Antenna Polarization	EIRP Level (dBm)	Limit (dBm)	Margin (dB)	Azimuth (deg)
2	3421.9	-55.15	2.6	10.15	Horizontal	-47.6	-13.00	34.6	315
3	5133.0	-56.15	2.4	11.35	Horizontal	-47.2	-13.00	34.2	270
4	6880.0	-51.85	4.5	10.85	Horizontal	-45.5	-13.00	32.5	45
5	8600.0	-48.65	5.1	11.35	Horizontal	-42.4	-13.00	29.4	225
6	10320.0	-47.75	5.3	11.95	Horizontal	-41.1	-13.00	28.1	180
7	12040.0	-46.95	5.5	13.55	Horizontal	-38.9	-13.00	25.9	270
8	13760.0	-44.85	6.3	13.75	Horizontal	-37.4	-13.00	24.4	90
9	15480.0	-47.55	6.7	13.85	Horizontal	-40.4	-13.00	27.4	90
10	17200.0	-44.35	6.8	14.25	Horizontal	-36.9	-13.00	23.9	225

Note: 1.The other Spurious RF Radiated emissions level is no more than noise floor.

2. The worst emission was found in the antenna is Horizontal position.

LTE Band 66 QPSK 20MHz CH-Middle, RB 1

Harmonic	Frequency (MHz)	SG (dBm)	Cable Loss (dB)	Gain (dBi)	Antenna Polarization	EIRP Level (dBm)	Limit (dBm)	Margin (dB)	Azimuth (deg)
2	3447.0	-55.75	2.6	10.75	Horizontal	-47.6	-13.00	34.6	45
3	5170.5	-56.05	2.4	11.05	Horizontal	-47.4	-13.00	34.4	225
4	6930.0	-52.45	4.5	11.15	Horizontal	-45.8	-13.00	32.8	270
5	8662.5	-48.65	5.1	11.35	Horizontal	-42.4	-13.00	29.4	90
6	10395.0	-46.55	5.3	11.95	Horizontal	-39.9	-13.00	26.9	225
7	12127.5	-46.95	5.5	13.55	Horizontal	-38.9	-13.00	25.9	315
8	13860.0	-44.55	6.3	13.75	Horizontal	-37.1	-13.00	24.1	180
9	15592.5	-46.95	6.7	13.85	Horizontal	-39.8	-13.00	26.8	45
10	17325.0	-44.95	6.8	14.25	Horizontal	-37.5	-13.00	24.5	180

Note: 1.The other Spurious RF Radiated emissions level is no more than noise floor.

2. The worst emission was found in the antenna is Horizontal position.

LTE Band 66 QPSK 20MHz CH-High, RB 1

Harmonic	Frequency (MHz)	SG (dBm)	Cable Loss (dB)	Gain (dBi)	Antenna Polarization	EIRP Level (dBm)	Limit (dBm)	Margin (dB)	Azimuth (deg)
2	3472.1	-54.85	2.6	10.15	Horizontal	-47.3	-13.00	34.3	315
3	5208.4	-56.85	2.4	11.05	Horizontal	-48.2	-13.00	35.2	225
4	6980.0	-52.05	4.5	11.15	Horizontal	-45.4	-13.00	32.4	45
5	8725.0	-48.85	5.1	11.35	Horizontal	-42.6	-13.00	29.6	180
6	10470.0	-45.65	5.3	11.95	Horizontal	-39.0	-13.00	26.0	270
7	12215.0	-47.55	5.5	13.55	Horizontal	-39.5	-13.00	26.5	315
8	13960.0	-44.75	6.3	13.75	Horizontal	-37.3	-13.00	24.3	90
9	15705.0	-45.85	6.7	13.85	Horizontal	-38.7	-13.00	25.7	180
10	17450.0	-44.45	6.8	14.25	Horizontal	-37.0	-13.00	24.0	135

Note: 1.The other Spurious RF Radiated emissions level is no more than noise floor.

2. The worst emission was found in the antenna is Horizontal position.

6 Main Test Instruments

Name	Manufacturer	Type	Serial Number	Calibration Date	Expiration Date
Base Station Simulator	R&S	CMW500	113645	2017-05-14	2018-05-13
Power Splitter	Hua Xiang	SHX-GF2-2-13	10120101	2017-05-14	2018-05-13
Universal Radio Communication Tester	Agilent	E5515C	MY48367192	2017-05-14	2018-05-13
Spectrum Analyzer	Agilent	N9010A	MY47191109	2017-05-14	2018-05-13
Signal Analyzer	R&S	FSV30	100815	2016-12-18	2017-12-17
Signal Analyzer	R&S	FSV30	100815	2017-12-17	2018-12-16
Signal generator	R&S	SMB 100A	102594	2017-05-14	2018-05-13
EMI Test Receiver	R&S	ESCI	100948	2017-05-20	2018-05-19
Trilog Antenna	SCHWARZBECK	VUBL 9163	9163-201	2017-11-18	2020-11-17
Horn Antenna	R&S	HF907	100126	2014-12-06	2019-12-05
Horn Antenna	ETS-Lindgren	3160-09	00102643	2015-01-30	2018-01-29
Climatic Chamber	Re Ce	PT-30B	20101891	2015-07-18	2018-07-17
RF Cable	Agilent	SMA 15cm	0001	2017-08-04	2018-02-03
Preamplifier	R&S	SCU18	102327	2017-06-18	2018-06-17
Software	R&S	EMC32	V 8.52.0	NA	NA

*****END OF REPORT *****