



中国认可  
国际互认  
检测  
TESTING  
CNAS L2264

## RF TEST REPORT

**Applicant** ZTE Corporation

**FCC ID** SRQ-ZTEB2017G

**Product** LTE/WCDMA/CDMA/GSM (GPRS)  
Mutil-Mode Digital Mobile Phone

**Brand** ZTE

**Model** ZTE B2017G

**Report No.** RXA1607-0132RF06

**Issue Date** September 1, 2016

TA Technology (Shanghai) Co., Ltd. tested the above equipment in accordance with the requirements in **FCC CFR47 Part 15C (2015)**. The test results show that the equipment tested is capable of demonstrating compliance with the requirements as documented in this report.

Performed by: Xianqing Li

Reviewed by: Kai Xu

---

### TA Technology (Shanghai) Co., Ltd.

No.145, Jintang Rd, Tangzhen Industry Park, Pudong Shanghai, China

TEL: +86-021-50791141/2/3

FAX: +86-021-50791141/2/3-8000



# TABLE OF CONTENT

- 1. Test Laboratory ..... 4
  - 1.1. Notes of the test report..... 4
  - 1.2. Test facility ..... 4
  - 1.3. Testing Location ..... 5
- 2. General Description of Equipment under Test..... 6
- 3. Applied Standards ..... 8
- 4. Test Configuration ..... 9
- 5. Test Case Results ..... 10
  - 5.1. 20dB Bandwidth ..... 10
  - 5.2. Frequency Stability..... 12
  - 5.3. Radiates Emission ..... 14
  - 5.4. Conducted Emission ..... 21
- 6. Main Test Instruments ..... 24
- ANNEX A: EUT Appearance and Test Setup ..... 25
  - A.1 EUT Appearance ..... 25
  - A.2 Test Setup ..... 25



## Summary of measurement results

Number	Summary of measurements of results	Clause in FCC rules	Verdict
1	20 dB bandwidth	2.1049	PASS
2	Frequency Stability Tolerance	15.225(e)	PASS
3	Radiated Emissions	15.225 (a) (b) (c) (d) and 15.209	PASS
4	Conducted Emissions	15.207	PASS

Date of Testing: July 10, 2016 ~ August 12, 2016

## 1. Test Laboratory

### 1.1. Notes of the test report

This report shall not be reproduced in full or partial, without the written approval of TA technology (shanghai) co., Ltd).The results documented in this report apply only to the tested sample, under the conditions and modes of operation as described herein .Measurement Uncertainties were not taken into account and are published for informational purposes only. This report is written to support regulatory compliance of the applicable standards stated above. This report must not be used by the client to claim product certification, approval, or endorsement by CNAS or any government agencies.

### 1.2. Test facility

#### **CNAS (accreditation number: L2264)**

TA Technology (Shanghai) Co., Ltd. has obtained the accreditation of China National Accreditation Service for Conformity Assessment (CNAS).

#### **FCC (recognition number is 428261)**

TA Technology (Shanghai) Co., Ltd. has been listed on the US Federal Communications Commission list of test facilities recognized to perform electromagnetic emissions measurements.

#### **IC (recognition number is 8510A)**

TA Technology (Shanghai) Co., Ltd. has been listed by industry Canada to perform electromagnetic emission measurement.

#### **VCCI (recognition number is C-4595, T-2154, R-4113, G-766)**

TA Technology (Shanghai) Co., Ltd. has been listed by industry Japan to perform electromagnetic emission measurement.

#### **A2LA (Certificate Number: 3857.01)**

TA Technology (Shanghai) Co., Ltd. has been listed by American Association for Laboratory Accreditation to perform electromagnetic emission measurement.



### 1.3. Testing Location

Company: TA Technology (Shanghai) Co., Ltd.  
Address: No.145, Jintang Rd, Tangzhen Industry Park, Pudong  
City: Shanghai  
Post code: 201201  
Country: P. R. China  
Contact: Xu Kai  
Telephone: +86-021-50791141/2/3  
Fax: +86-021-50791141/2/3-8000  
Website: <http://www.ta-shanghai.com>  
E-mail: [xukai@ta-shanghai.com](mailto:xukai@ta-shanghai.com)



## 2. General Description of Equipment under Test

### Client Information

<b>Applicant</b>	ZTE Corporation
<b>Applicant address</b>	ZTE Plaza, Keji Road South, Hi-Tech Industrial Park, Nanshan District, Shenzhen, Guangdong,518057, P.R. China
<b>Manufacturer</b>	ZTE Corporation
<b>Manufacturer address</b>	ZTE Plaza, Keji Road South, Hi-Tech Industrial Park, Nanshan District, Shenzhen, Guangdong,518057, P.R. China

**General information**

Model:	ZTE B2017G
IMEI:	SIM1:860935030016782 SIM2:860935030018788
Hardware Version:	uj3A
Software Version:	ZTE B2017G_USAV1.0.0B01
Power Supply:	Battery/AC adapter
Antenna Type:	Internal Antenna
Test Mode:	NFC
Modulation Type:	ASK
Operating Frequency Range(s)	13.56MHz
EUT Accessory	
Battery 1	Manufacturer: SHENZHEN RUIDE ELECTRONIC INDUSTRIAL CO.,LTD Model: Li3927T44P8h726044 Power Rating: 3.85V/2705mAh
Battery 2	Manufacturer: SCUD (Fujian) Electronics Co., Ltd. Model: Li3927T44P8h726044 Power Rating: 3.85V/2705mAh
Earphone	Manufacturer: KINGSTATE ELECTRONICS CORP. Model: KJAG4020AWKCB-2
Adapter	Manufacturer: Salcomp (Shenzhen) Co., Ltd Model: STC-A5915A-Z Input power: 100-240Vac, 50/60Hz, 0.45A Output power: 5.0V, 1.5A/9.0V, 1.5A
Phone cover	Manufacturer: Shenzhen senyuanxiang Technology Co. Ltd. Model: senyuanxiang
<p>Note: The information of the EUT is declared by the manufacturer. Please refer to the specifications or user manual for details.</p>	



### 3. Applied Standards

According to the specifications of the manufacturer, it must comply with the requirements of the following standards:

#### Test standards

- FCC CFR47 Part 2 (2015)
- FCC CFR47 Part 15C (2015)
- ANSI C63.10 (2013)



## 4. Test Configuration

### Test Mode

The EUT was programmed to be in continuously transmitting mode and the transmit duty cycle is not less than 98%.

The EUT has been associated with peripherals and configuration operated in a manner tended to maximize its emission characteristics in a typical application.

## 5. Test Case Results

### 5.1. 20dB Bandwidth

#### Ambient condition

Temperature	Relative humidity	Pressure
23°C ~25°C	45%~50%	101.5kPa

#### Method of Measurement

The EUT was connected to the spectrum analyzer through an external attenuator (20dB) and a known loss cable. RBW is set to 10 kHz; VBW is set to 3 times thw RBW on spectrum analyzer.

#### Test Setup

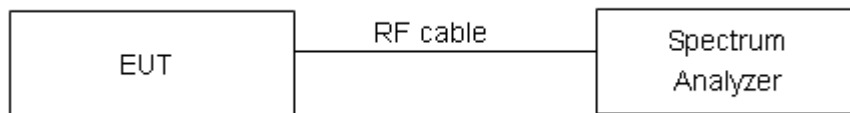

#### Limits

No specific occupied bandwidth requirements in part 2.1049.

#### Measurement Uncertainty

The assessed measurement uncertainty to ensure 95% confidence level for the normal distribution is with the coverage factor  $k = 2$ ,  $U = 936$  Hz.

**Test Results:**

Carrier frequency (MHz)	99% Bandwidth (kHz)	20dB Bandwidth (kHz)	Conclusion
13.56MHz	22.464	25.46	PASS

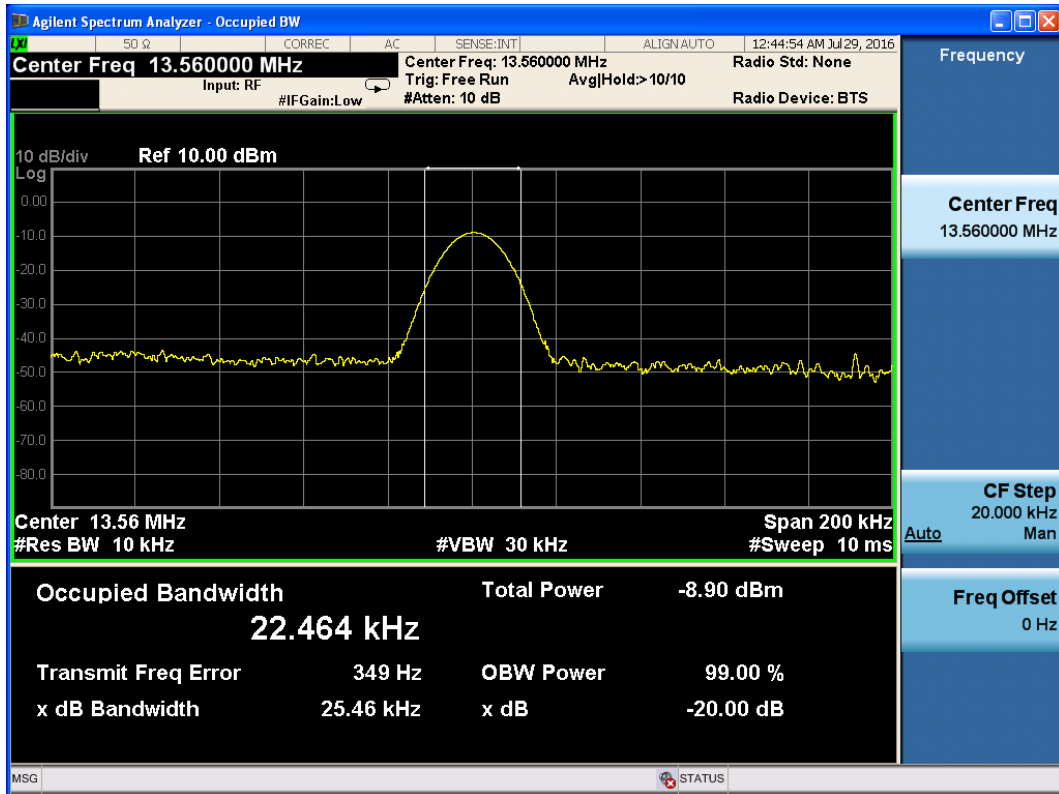

## 5.2. Frequency Stability

### Ambient condition

Temperature	Relative humidity
21°C ~25°C	40%~60%

### Method of Measurement

1. Frequency Stability (Temperature Variation)

The temperature inside the climate chamber is varied from -20°C to +50°C in 10°C step size,

(1) With all power removed, the temperature was decreased to 0°C and permitted to stabilize for three hours.

(2) Measure the carrier frequency with the test equipment in a “call mode”. These measurements should be made within 1 minute of powering up the mobile station, to prevent significant self warming.

(3) Repeat the above measurements at 10°C increments from -20°C to +50°C. Allow at least 1.5 hours at each temperature, un-powered, before making measurements.

2. Frequency Stability (Voltage Variation)

The frequency stability shall be measured with variation of primary supply voltage as follows:

(1) Vary primary supply voltage from 85 to 115 percent of the nominal value for other than hand carried battery equipment.

(2) For hand carried, battery powered equipment, reduce primary supply voltage to the battery-operating end point which shall be specified by the manufacturer.

This transceiver is specified to operate with an input voltage of between 3.4 V and 4.4 V, with a nominal voltage of 3.85V.

### Test setup

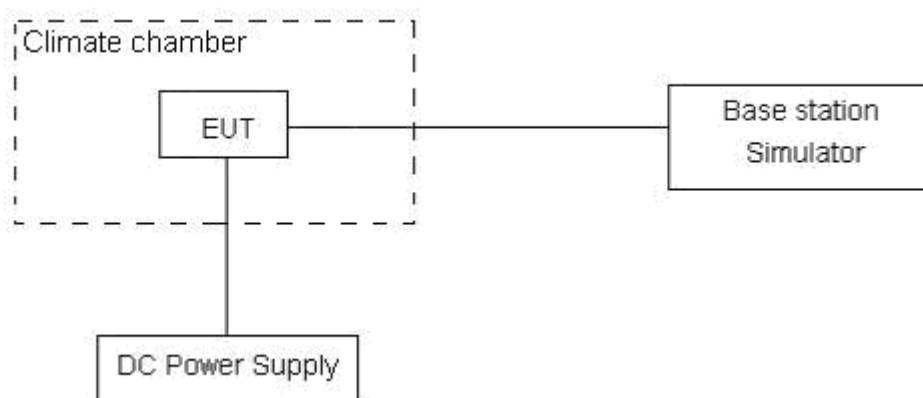

**Limits**

Rule Part 15.225 (e) The frequency tolerance of the carrier signal shall be maintained within  $\pm 0.01\%$  of the operating frequency over a temperature variation of  $-20$  degrees to  $+ 50$  degrees C at normal supply voltage, and for a variation in the primary supply voltage from 85% to 115% of the rated supply voltage at a temperature of 20 degrees C. For battery operated equipment, the equipment tests shall be performed using a new battery.

**Measurement Uncertainty**

The assessed measurement uncertainty to ensure 99.75% confidence level for the normal distribution is with the coverage factor  $k = 3$ ,  $U = 0.01\text{ppm}$ .

**Test Result**

Test status	Frequency				Tolerance (MHz)			
	13.56MHz				1min	2min	5min	10min
	1min	2min	5min	10min				
-20°C/3.85 V	13.559343	13.559293	13.559307	13.559285	0.000657	0.000707	0.000693	0.000715
-10°C/3.85 V	13.559313	13.559287	13.559301	13.559281	0.000687	0.000713	0.000699	0.000719
0°C/3.85 V	13.559297	13.559284	13.559291	13.559278	0.000703	0.000716	0.000709	0.000722
10°C/3.85 V	13.559293	13.559282	13.559285	13.559274	0.000707	0.000718	0.000715	0.000726
20°C/3.85 V	13.559279	13.559277	13.559279	13.559272	0.000721	0.000723	0.000721	0.000728
30°C/3.85 V	13.559269	13.559276	13.559272	13.559271	0.000731	0.000724	0.000728	0.000729
40°C/3.85 V	13.559261	13.559272	13.559268	13.559267	0.000739	0.000728	0.000732	0.000733
50°C/3.85 V	13.559256	13.559268	13.559264	13.559262	0.000744	0.000732	0.000736	0.000738
20°C/3.4 V	13.559272	13.559274	13.559277	13.559268	0.000728	0.000726	0.000723	0.000732
20°C/4.4 V	13.559269	13.559269	13.559272	13.559267	0.000731	0.000731	0.000728	0.000733

Test status	Tolerance (%)				Limit 0.01%	Conclusion
	1min	2min	5min	10min		
-20°C/3.85 V	0.004845	0.005214	0.005111	0.005273	pass	PASS
-10°C/3.85 V	0.005066	0.005258	0.005155	0.005302	pass	PASS
0°C/3.85 V	0.005184	0.005280	0.005229	0.005325	pass	PASS
10°C/3.85 V	0.005214	0.005295	0.005273	0.005354	pass	PASS
20°C/3.85 V	0.005317	0.005332	0.005317	0.005369	pass	PASS
30°C/3.85 V	0.005391	0.005339	0.005369	0.005376	pass	PASS
40°C/3.85 V	0.005450	0.005369	0.005398	0.005406	pass	PASS
50°C/3.85 V	0.005487	0.005398	0.005428	0.005443	pass	PASS
20°C/3.4 V	0.005369	0.005354	0.005332	0.005398	pass	PASS
20°C/4.4 V	0.005391	0.005391	0.005369	0.005406	pass	PASS

### 5.3. Radiates Emission

#### Ambient condition

Temperature	Relative humidity	Pressure
23°C ~25°C	45%~50%	102.5kPa

#### Method of Measurement

The test set-up was made in accordance to the general provisions of ANSI C63.10-2013. The Equipment Under Test (EUT) was set up on a non-conductive table in the semi-anechoic chamber. The test was performed at the distance of 3 m between the EUT and the receiving antenna. The radiated emissions measurements were made in a typical installation configuration.

Sweep the whole frequency band through the range from 9 kHz to the 10th harmonic of the carrier, and the emissions less than 20 dB below the permissible value are reported.

During the test, below 30MHz, the center of the loop shall be 1 meters; above 30MHz, the height of receive antenna shall be moved from 1 to 4 meters, and the antenna shall be performed under horizontal and vertical polarization. The turntable shall be rotated from 0 to 360 degrees for detecting the maximum of radiated spurious signal level. The measurements shall be repeated with orthogonal polarization of the test antenna. The data of cable loss and antenna factor has been calibrated in full testing frequency range before the testing.

Set the spectrum analyzer in the following:

Below 1GHz (detector: Peak and Quasi-Peak)

RBW=100 kHz / VBW=300 kHz / Sweep=AUTO

Above 1GHz (detector: Peak):

(a) PEAK: RBW=1MHz VBW=3MHz/ Sweep=AUTO

(b) AVERAGE: RBW=1MHz / VBW=3MHz / Sweep=AUTO

The radiated emission was measured in the following position: EUT stand-up position (Z axis), lie-down position (X, Y axis). The worst emission was found in stand-up position (Z axis) and the worst case was recorded.

The test is in transmitting mode.

**Test setup**

**9kHz~~~ 30MHz**

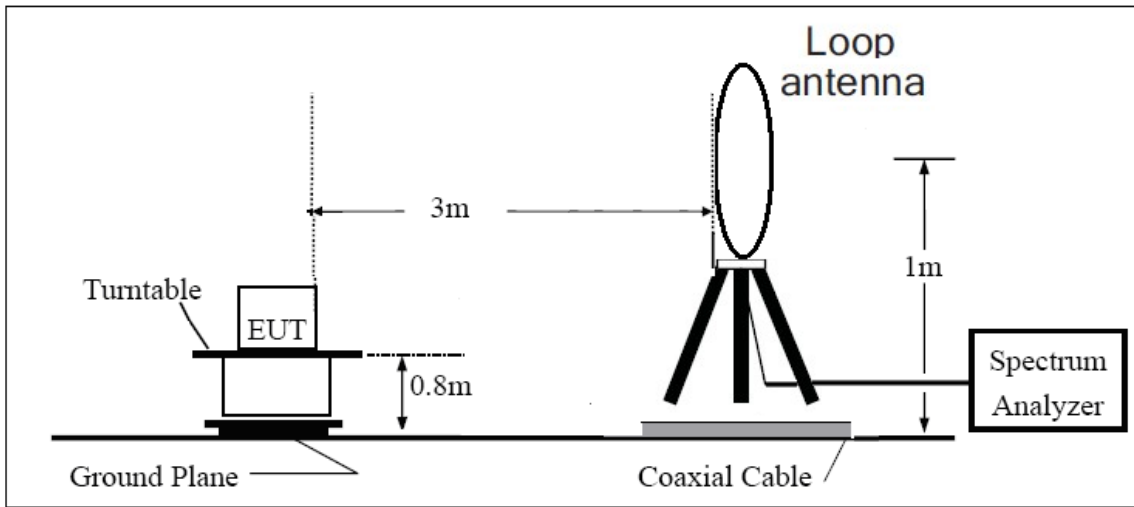

**30MHz~~~ 1GHz**

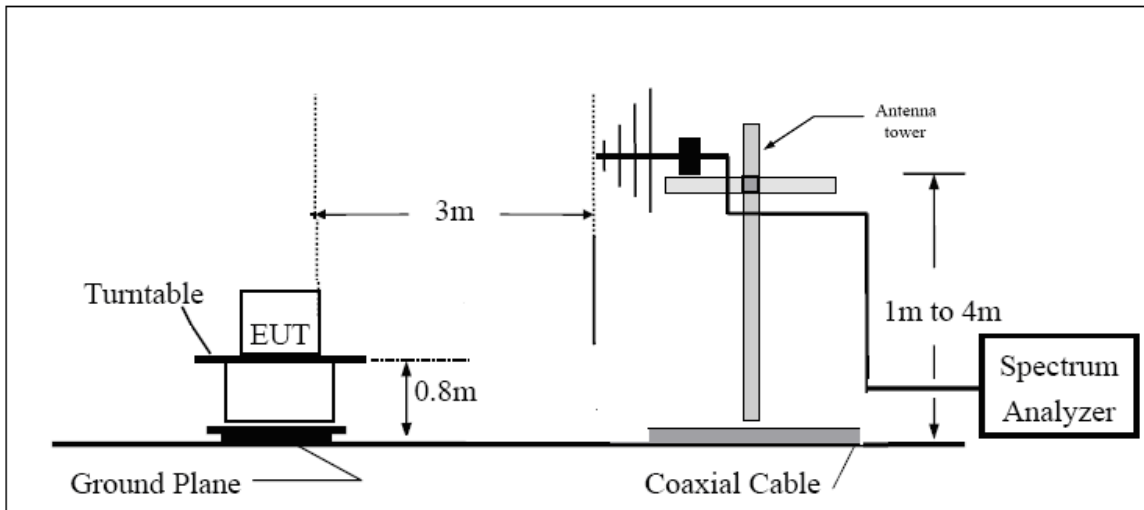

**Above 1GHz**

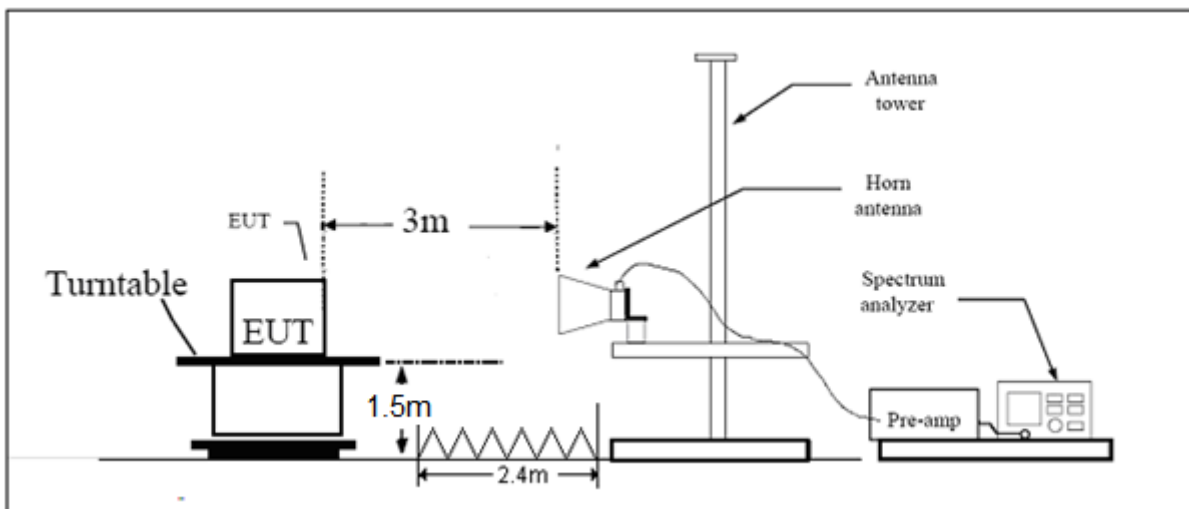

Note: Area side:2.4mX3.6m

**Limits**

Clause 15.225(a) the field strength of any emissions within the band 13.553-13.567 MHz shall not exceed 15,848 microvolts/meter at 30 meters.

Clause 15.225(b) within the bands 13.410-13.553 MHz and 13.567-13.710 MHz, the field strength of any emissions shall not exceed 334 microvolts/meter at 30 meters.

Clause 15.225(c) within the bands 13.110-13.410 MHz and 13.710-14.010 MHz the field strength of any emissions shall not exceed 106 microvolts/meter at 30 meters.

Clause 15.225(d) The field strength of any emissions appearing outside of the 13.110-14.010 MHz band shall not exceed the general radiated emission limits in §15.209.

§15.209 (a) Except as provided elsewhere in this subpart, the emissions from an intentional radiator shall not exceed the field strength levels specified in the following table:

Frequency of emission (MHz)	Field strength(uV/m)	Field strength(dBuV/m)
0.009–0.490	2400/F(kHz)	/
0.490–1.705	24000/F(kHz)	/
1.705–30.0	30	/
30-88	100	40
88-216	150	43.5
216-960	200	46
Above960	500	54

\*\*Except as provided in paragraph (g), fundamental emissions from intentional radiators operating under this section shall not be located in the frequency bands 54-72 MHz, 76-88 MHz, 174-216 MHz or 470-806 MHz. However, operation within these frequency bands is permitted under other sections of this part, e.g., §§15.231 and 15.241.

§15.209 (b) In the emission table above, the tighter limit applies at the band edges.

§15.209 (d) The emission limits shown in the above table are based on measurements employing a CISPR quasi-peak detector except for the frequency bands 9-90 kHz, 110-490 kHz and above 1000 MHz. Radiated emission limits in these three bands are based on measurements employing an average detector.

**Measurement Uncertainty**

The assessed measurement uncertainty to ensure 95% confidence level for the normal distribution is with the coverage factor  $k = 1.96$ .

Frequency	Uncertainty
9kHz-30MHz	3.55 dB
30MHz-200MHz	4.19 dB
200MHz-1GHz	3.63 dB
Above 1GHz	3.68 dB

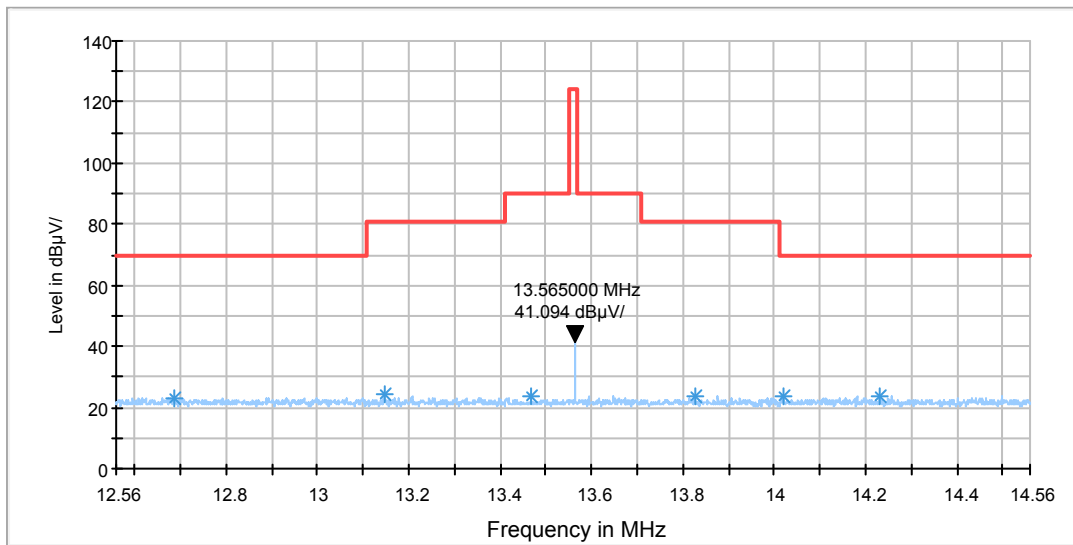
**Test result****In-band**

Radiates Emission from 12.56MHz to 14.56MHz

Note: This graph displays the maximum values of horizontal and vertical by software

**Out-of-band**

The following graphs display the maximum values of horizontal and vertical by software.  
 For above 1GHz, Blue trace uses the peak detection, Green trace uses the average detection.

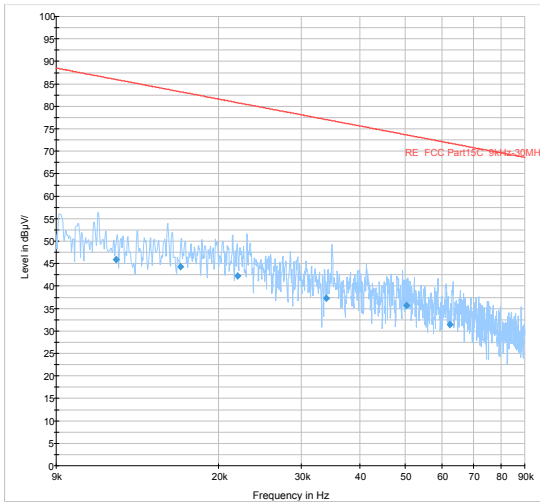

Radiates Emission from 9kHz to 90kHz

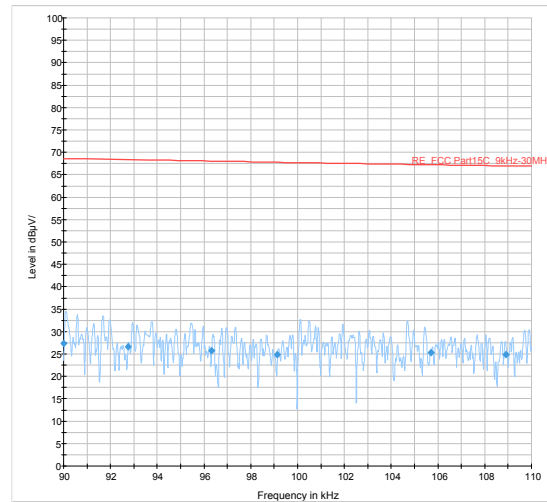

Radiates Emission from 90kHz to 110kHz

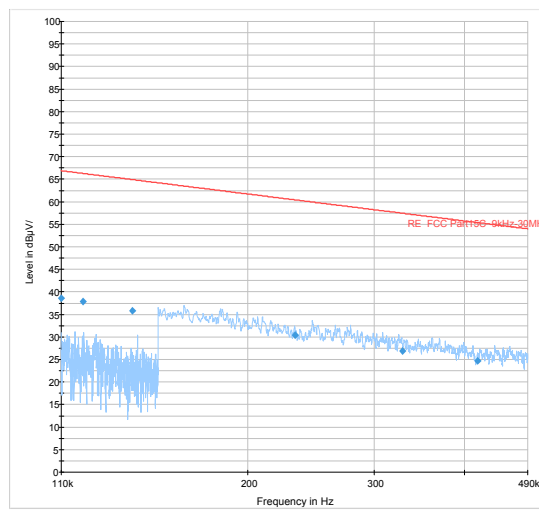

Radiates Emission from 110kHz to 490kHz

FCC RE 490K-30MHz QP

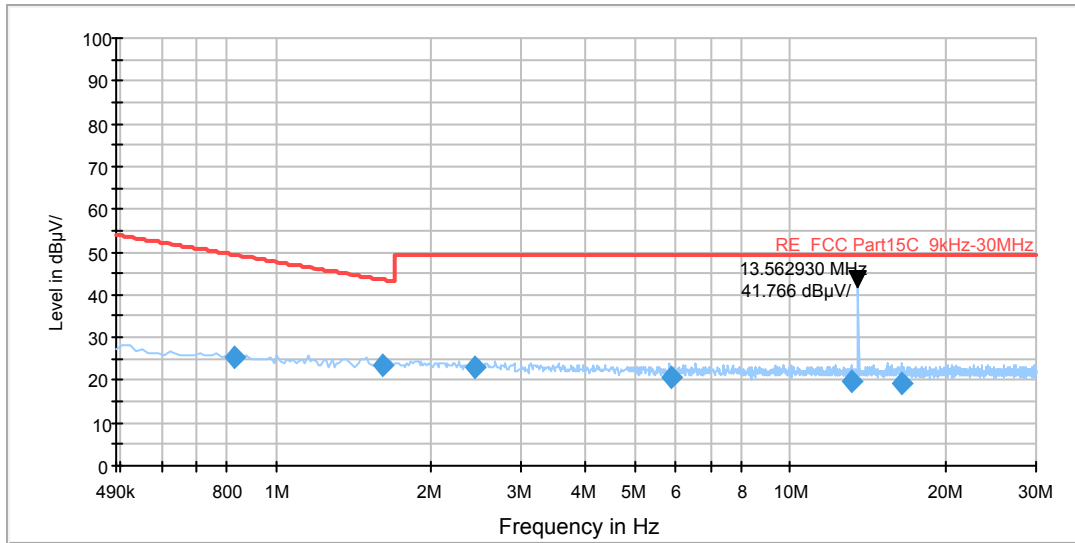

Radiates Emission from 490kHz to 30MHz

Frequency (MHz)	Quasi-Peak (dBuV/m)	Height (cm)	Polarization	Azimuth (deg)	Reading value (dBuV/m)	Correct Factor (dB)	Margin (dB)	Limit (dBuV/m)
0.828630	25.5	100.0	V	134.0	45.1	19.6	23.9	49.4
1.610645	23.4	100.0	V	0.0	42.8	19.4	20.1	43.5
2.436925	22.9	100.0	V	134.0	42.3	19.4	26.6	49.5
5.862310	20.7	100.0	V	0.0	40.0	19.3	28.8	49.5
13.123280	19.6	100.0	V	0.0	39.2	19.6	29.9	49.5
16.457910	19.4	100.0	V	0.0	39.0	19.6	30.1	49.5

- Remark: 1. Quasi-Peak = Reading value + Correction factor**  
**2. Correction Factor = Antenna factor+ Insertion loss (cable loss+amplifier gain)**  
**3. Margin = Limit – Quasi-Peak**

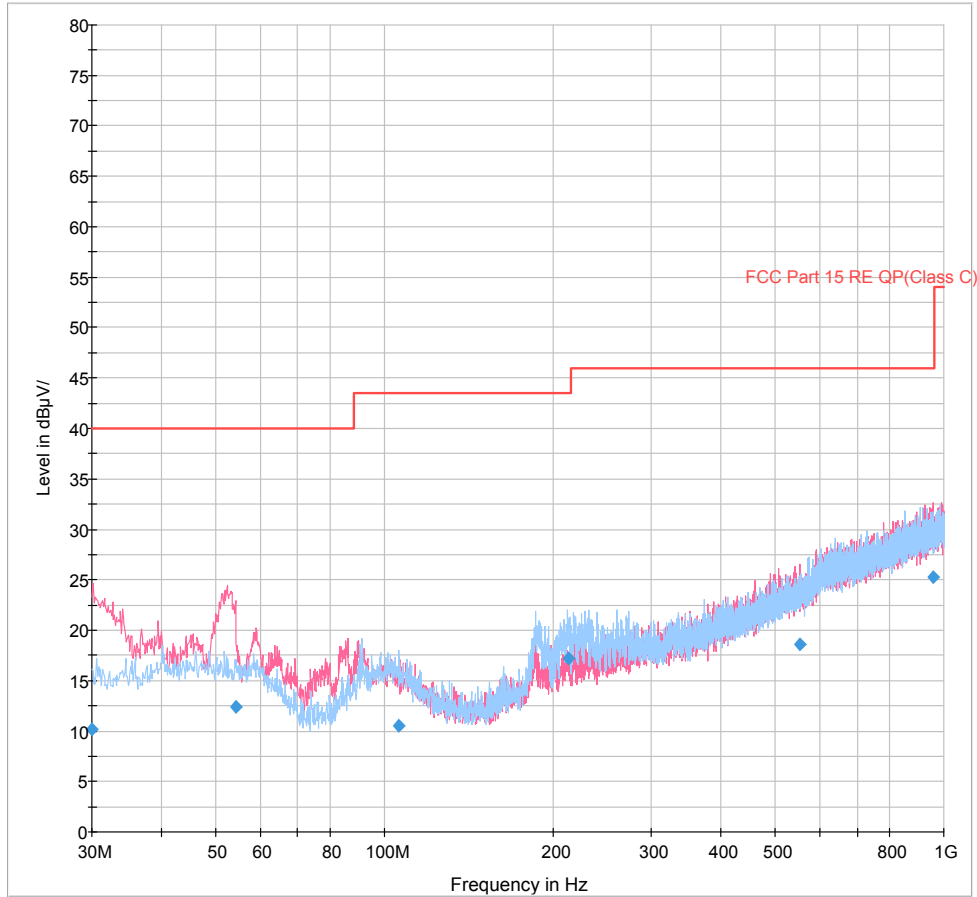

Radiates Emission from 30MHz to 1GHz

Note: This graph displays the maximum values of horizontal and vertical by software

Frequency (MHz)	Quasi-Peak (dBuV/m)	Height (cm)	Polarization	Azimuth (deg)	Reading value (dBuV/m)	Correct Factor (dB)	Margin (dB)	Limit (dBuV/m)
30.000000	10.2	100.0	V	333.0	22.1	11.9	29.8	40.0
54.368750	12.4	114.0	V	173.0	25.2	12.8	27.6	40.0
105.866250	10.6	125.0	H	113.0	23.3	12.7	32.9	43.5
213.323750	17.2	125.0	H	270.0	29.8	12.6	26.3	43.5
552.300000	18.6	100.0	V	286.0	39.7	21.1	27.4	46.0
956.183750	25.2	125.0	V	157.0	51.3	26.1	20.8	46.0

### 5.4. Conducted Emission

#### Ambient condition

Temperature	Relative humidity	Pressure
23°C ~25°C	45%~50%	101.5kPa

#### Methods of Measurement

The EUT is placed on a non-metallic table of 80cm height above the horizontal metal reference ground plane. During the test, the EUT was operating in its typical mode. The test method is according to ANSI C63.10-2013. Connect the AC power line of the EUT to the L.I.S.N. Use EMI receiver to detect the average and Quasi-peak value. RBW is set to 9 kHz, VBW is set to 30kHz. The measurement result should include both L line and N line.

The test is in transmitting mode.

#### Test Setup

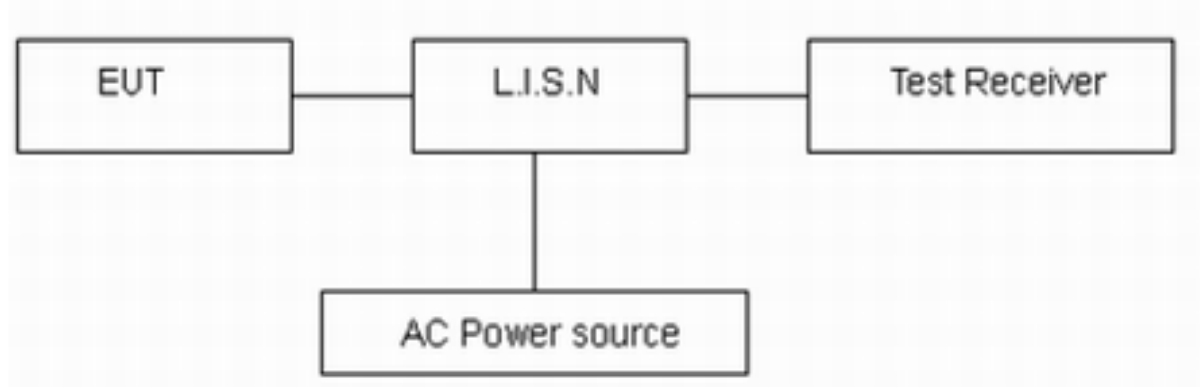

Note: AC Power source is used to change the voltage 110V/60Hz.

#### Limits

§15.207 (a) Except as shown in paragraphs (b) and (c) of this section, for an intentional radiator that is designed to be connected to the public utility (AC) power line, the radio frequency voltage that is conducted back onto the AC power line on any frequency or frequencies, within the band 150 kHz to 30 MHz, shall not exceed the limits in the following table, as measured using a 50 μH/50 ohms line impedance stabilization network (LISN). Compliance with the provisions of this paragraph shall be based on the measurement of the radio frequency voltage between each power line and ground at the power terminal. The lower limit applies at the boundary between the frequency ranges.

Frequency (MHz)	Conducted Limits(dBμV)	
	Quasi-peak	Average
0.15 - 0.5	66 to 56 *	56 to 46 *
0.5 - 5	56	46



5 - 30	60	50
*: Decreases with the logarithm of the frequency.		

### Measurement Uncertainty

The assessed measurement uncertainty to ensure 95% confidence level for the normal distribution is with the coverage factor  $k = 1.96$ ,  $U = 2.69$  dB.



Test Results:

Following plots, Blue trace uses the peak detection and Green trace uses the average detection.

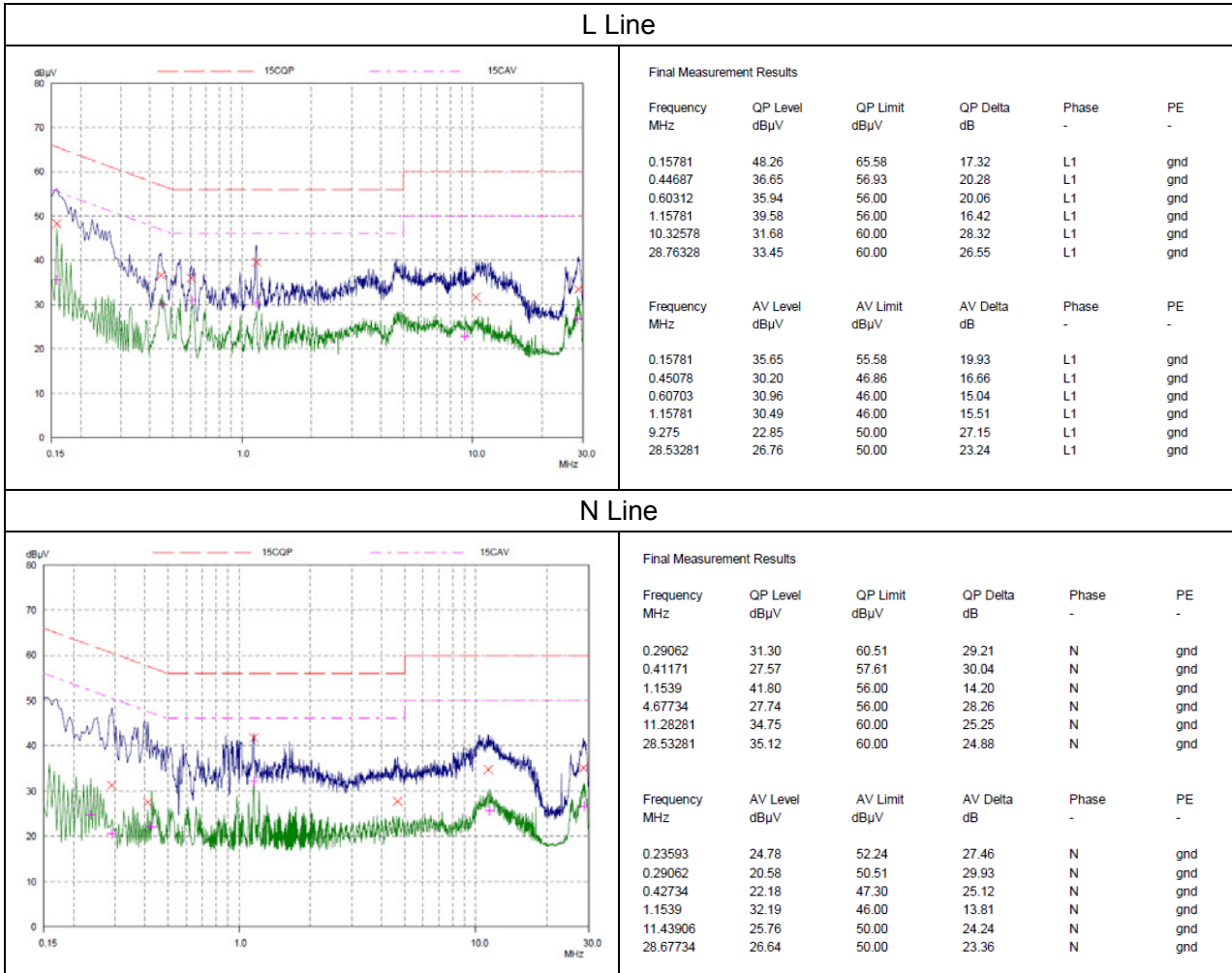



## 6. Main Test Instruments

Name	Type/ Model	Manufacturer	Serial Number	Calibration Date	Expiration Time
Spectrum Analyzer	FSV30	R&S	100815	2015-12-17	2016-12-16
EMI Test Receiver	ESCI	R&S	100948	2016-06-01	2017-05-31
TRILOG Broadband Antenna	VULB 9163	Schwarzbeck	9163-201	2014-12-06	2017-12-05
Loop Antenna	FMZB1519	SCHWARZBE CK	1519-047	2014-02-19	2017-02-18
EMI Test Receiver	ESCS30	R&S	100138	2015-12-17	2016-12-16
LISN	ENV216	R&S	101171	2013-12-18	2016-12-17
Spectrum Analyzer	N9010A	Agilent	MY47191109	2016-05-21	2017-05-20
MOB COMMS DC SUPPLY	66319D	Agilent	MY43004105	2016-05-21	2017-05-20
Peak Power Meter	U2021XA	Keysight	MY55240003	2016-06-26	2017-06-25
RF Cable	SMA 15cm	Agilent	0001	2016-06-06	2016-09-05

\*\*\*\*\*END OF REPORT \*\*\*\*\*

## ANNEX A: EUT Appearance and Test Setup

### A.1 EUT Appearance



a1: EUT

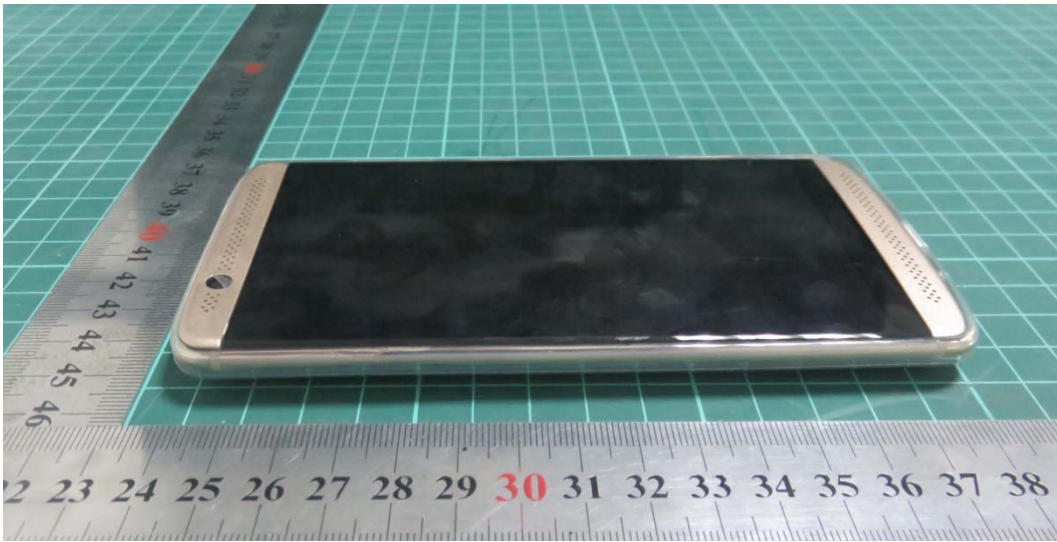

a2: EUT with Phone cover  
a: EUT



Phone cover

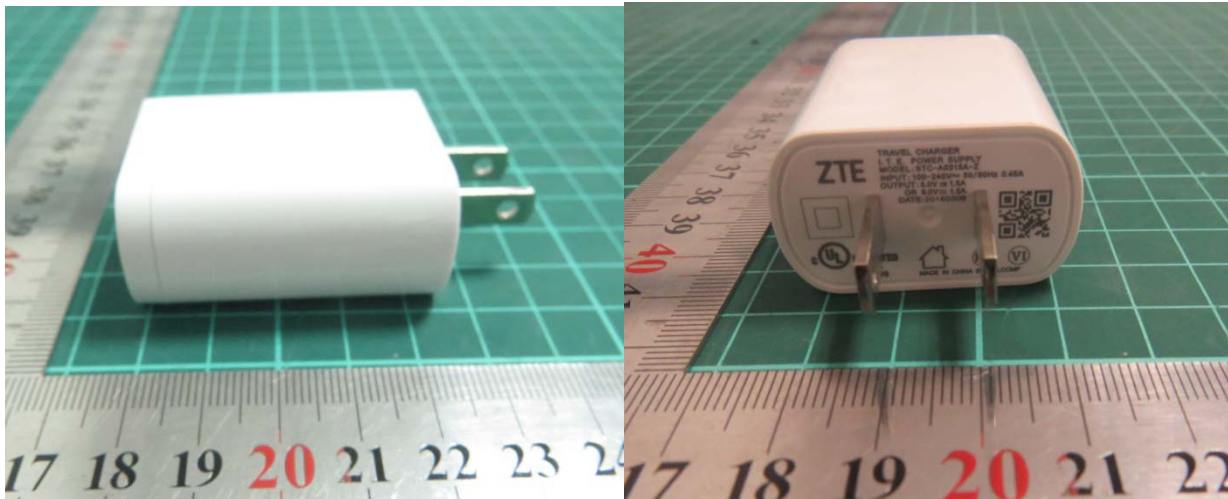

Adapter



Earphone

Picture 1 Constituents of EUT

## A.2 Test Setup



9kHz - 30MHz



30MHz - 1GHz

**Picture 2 Radiated Emission Test Setup**

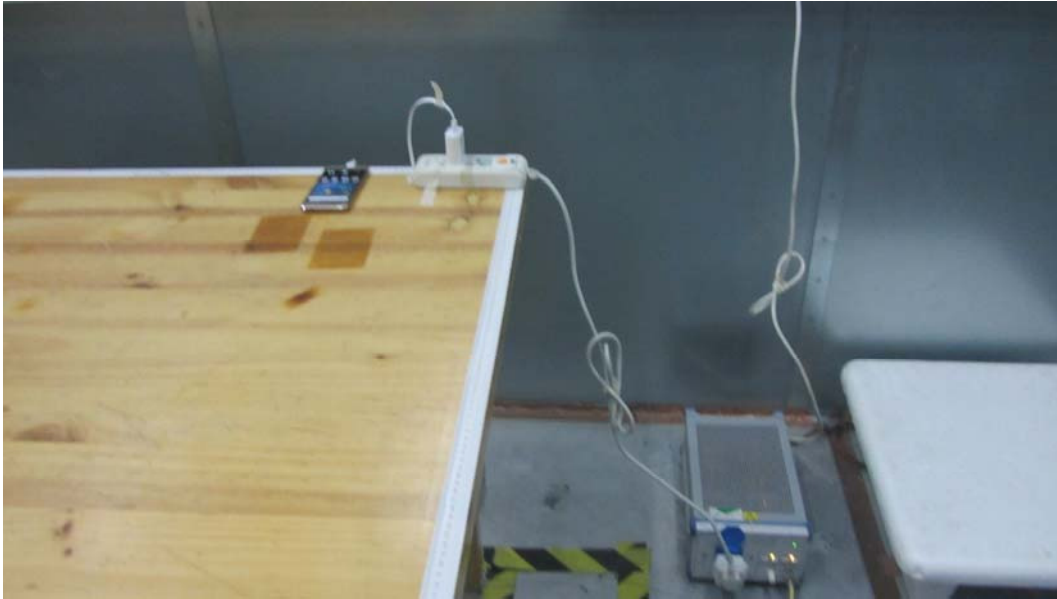

**Picture 3 Conducted Emission Test Setup**