

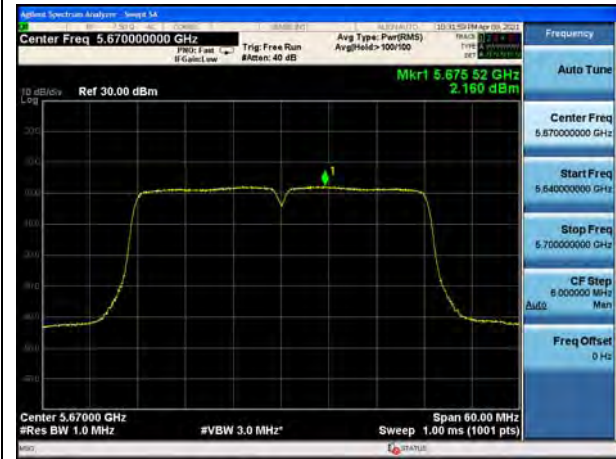

U-NII-2C, 802.11ac VHT40, Channel No.: 134

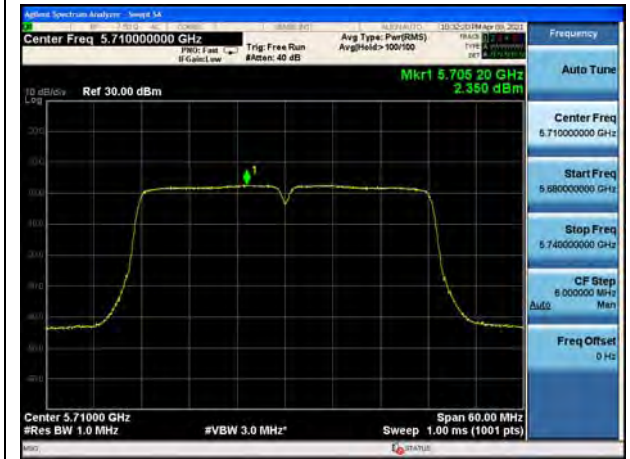

U-NII-2C, 802.11ac VHT40, Channel No.: 142



U-NII-2C, 802.11ac VHT80, Channel No.: 106



U-NII-2C, 802.11ac VHT80, Channel No.: 138

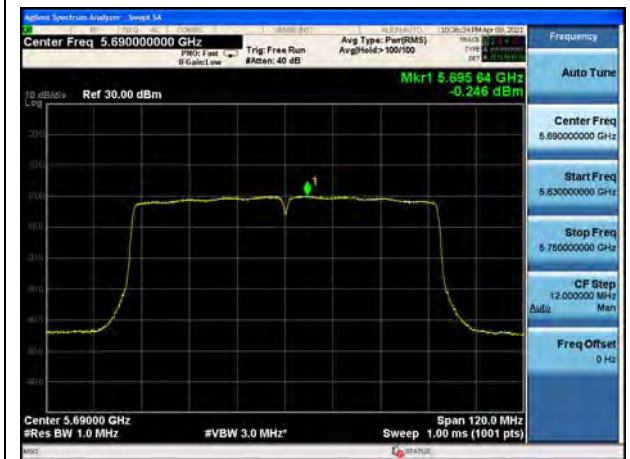

U-NII-2C, 802.11ax HE20, Channel No.: 100



U-NII-2C, 802.11ax HE20, Channel No.: 116

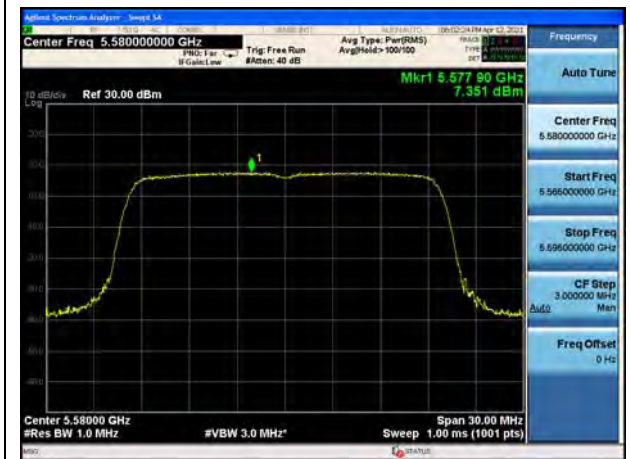



U-NII-2C, 802.11ax HE20, Channel No.: 140

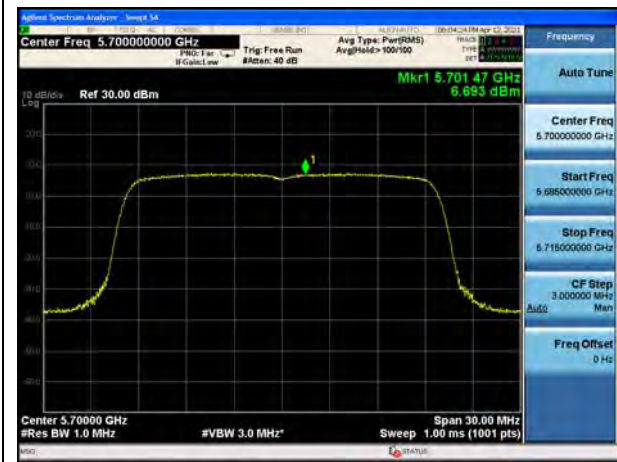

U-NII-2C, 802.11ax HE20, Channel No.: 144

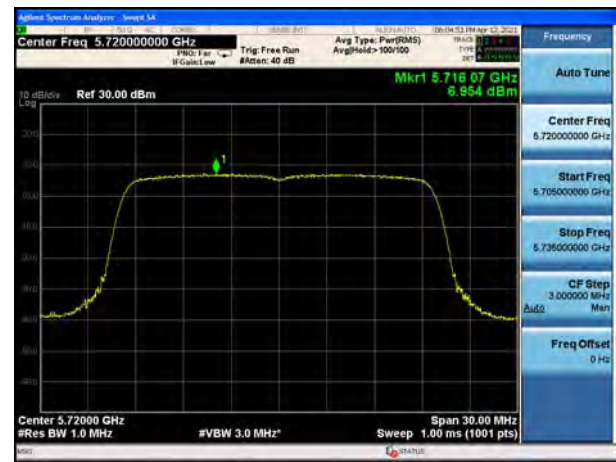

U-NII-2C, 802.11ax HE40, Channel No.: 102

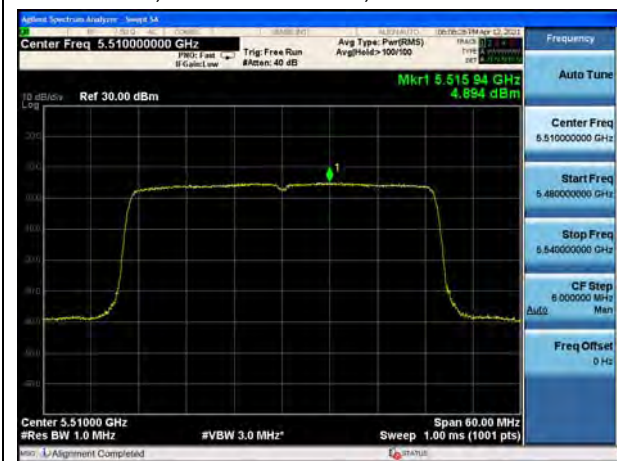

U-NII-2C, 802.11ax HE40, Channel No.: 110

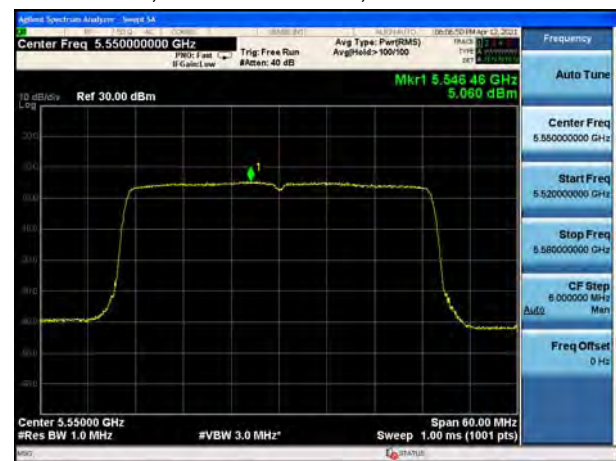

U-NII-2C, 802.11ax HE40, Channel No.: 134

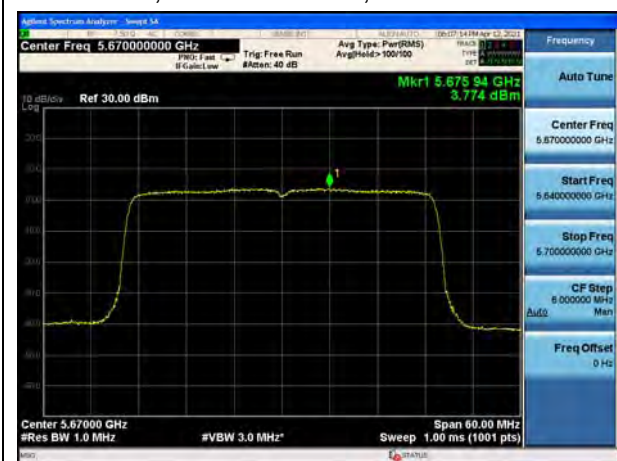

U-NII-2C, 802.11ax HE40, Channel No.: 142

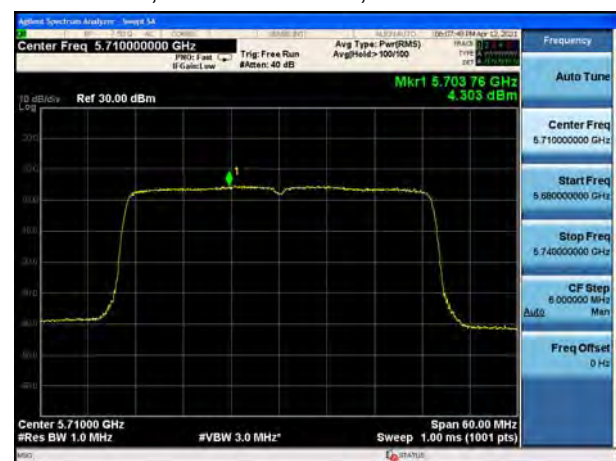



U-NII-2C, 802.11ax HE80, Channel No.: 106



U-NII-2C, 802.11ax HE80, Channel No.: 138

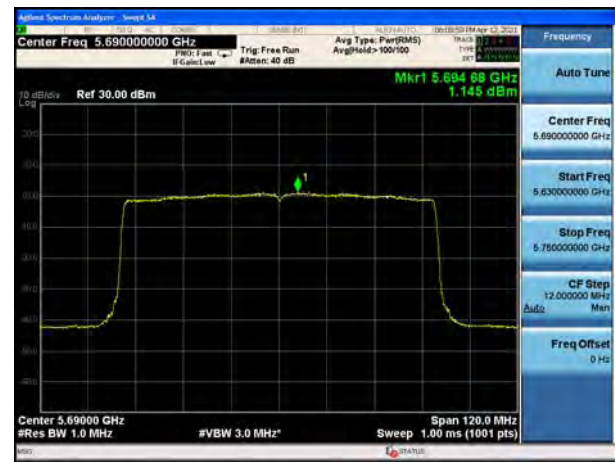

U-NII-2C, 802.11ax HE20 MU Mode 26-Tones, Channel No.: 100

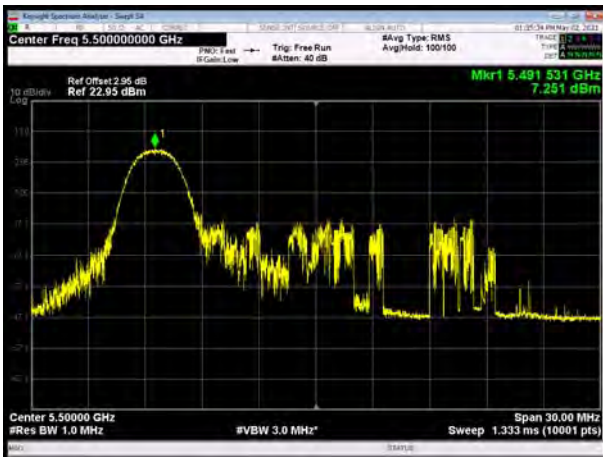

U-NII-2C, 802.11ax HE20 MU Mode 52-Tones, Channel No.: 100

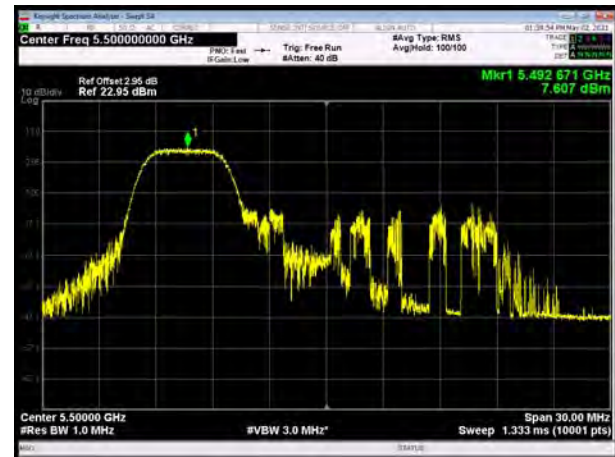

U-NII-2C, 802.11ax HE20 MU Mode 26-Tones, Channel No.: 116

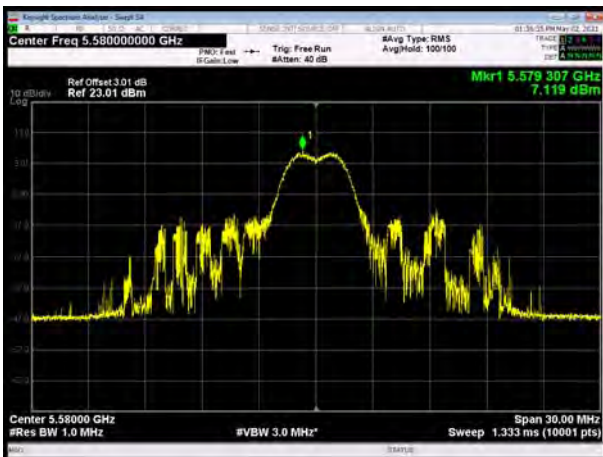

U-NII-2C, 802.11ax HE20 MU Mode 52-Tones, Channel No.: 116

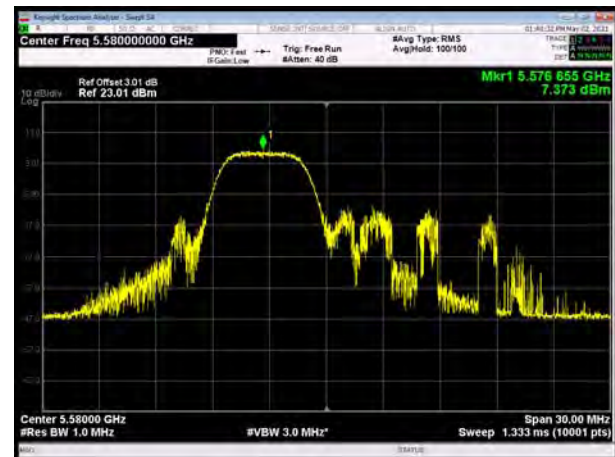

U-NII-2C, 802.11ax HE20 MU Mode 26-Tones,
Channel No.: 140

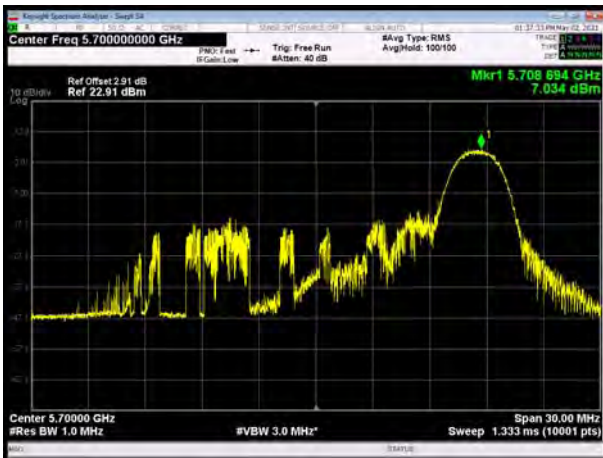

U-NII-2C, 802.11ax HE20 MU Mode 52-Tones,
Channel No.: 140

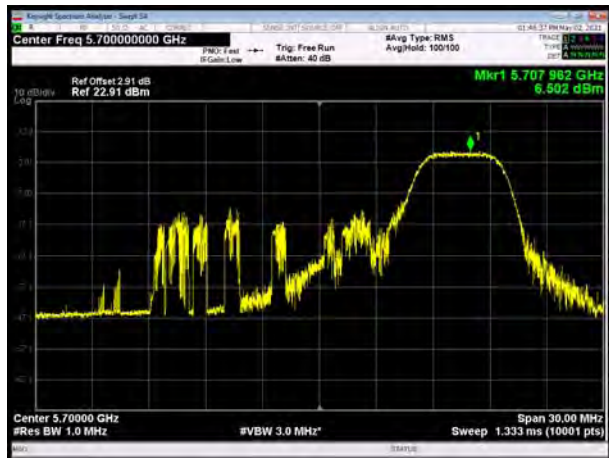

U-NII-2C, 802.11ax HE20 MU Mode 26-Tones,
Channel No.: 144

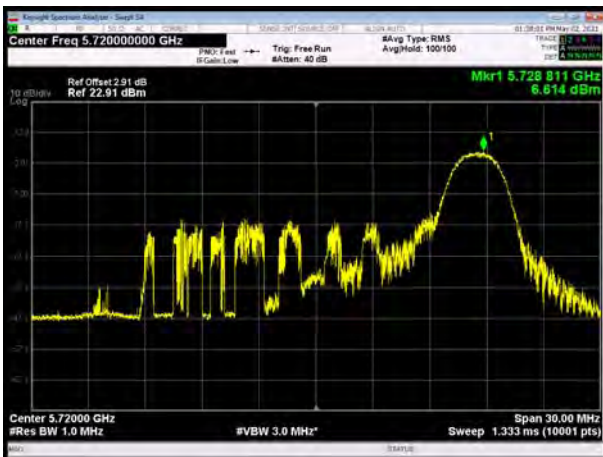

U-NII-2C, 802.11ax HE20 MU Mode 52-Tones,
Channel No.: 144

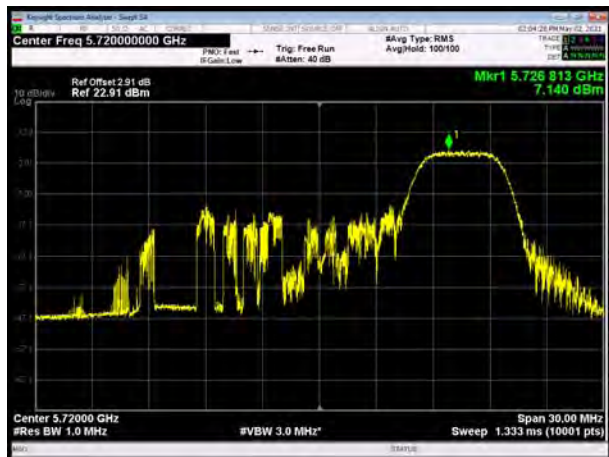

U-NII-2C, 802.11ax HE20 MU Mode 106-Tones,
Channel No.: 100

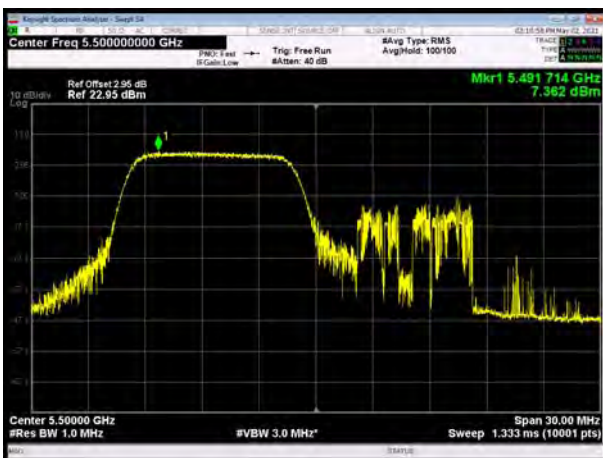

U-NII-2C, 802.11ax HE20 SU Mode 242-Tones,
Channel No.: 100

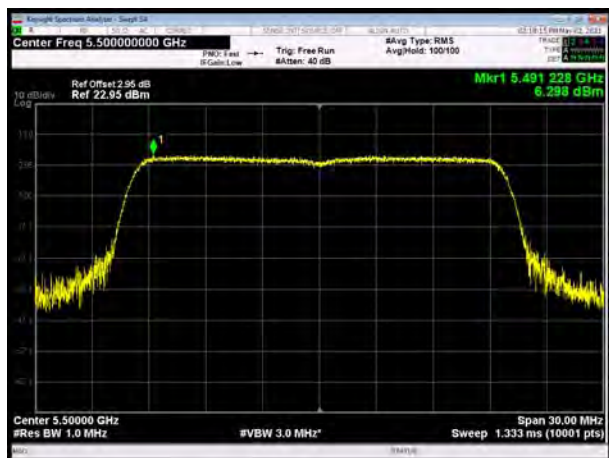

U-NII-2C, 802.11ax HE20 MU Mode 106-Tones,
Channel No.: 116

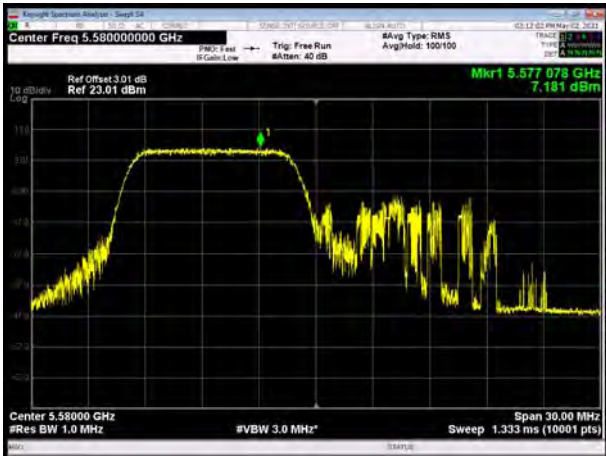

U-NII-2C, 802.11ax HE20 SU Mode 242-Tones,
Channel No.: 116

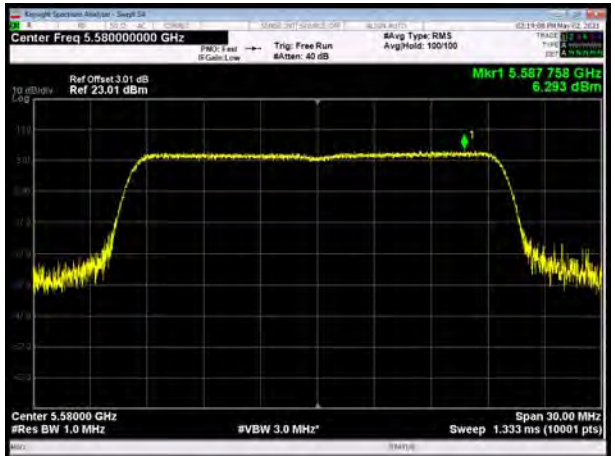

U-NII-2C, 802.11ax HE20 MU Mode 106-Tones,
Channel No.:140

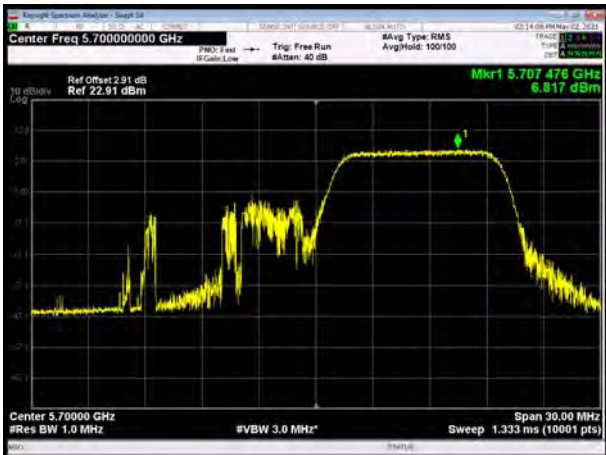

U-NII-2C, 802.11ax HE20 SU Mode 242-Tones,
Channel No.: 140

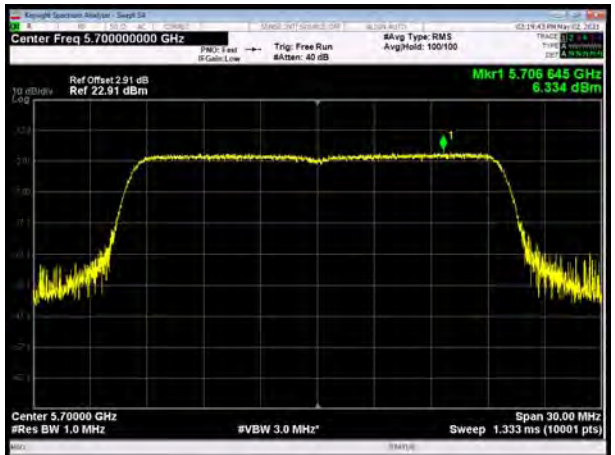

U-NII-2C, 802.11ax HE20 MU Mode 106-Tones,
Channel No.: 144

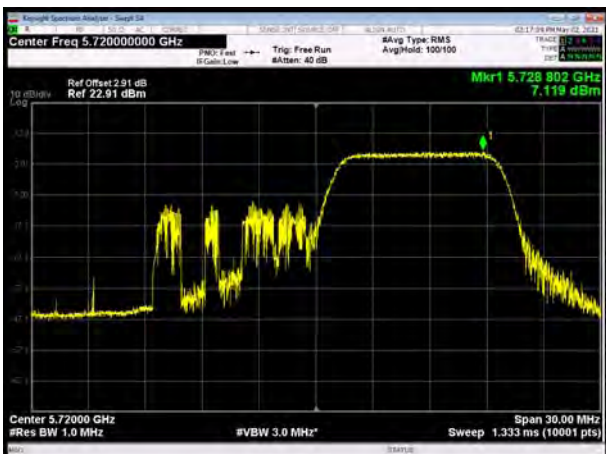

U-NII-2C, 802.11ax HE20 SU Mode 242-Tones,
Channel No.: 144

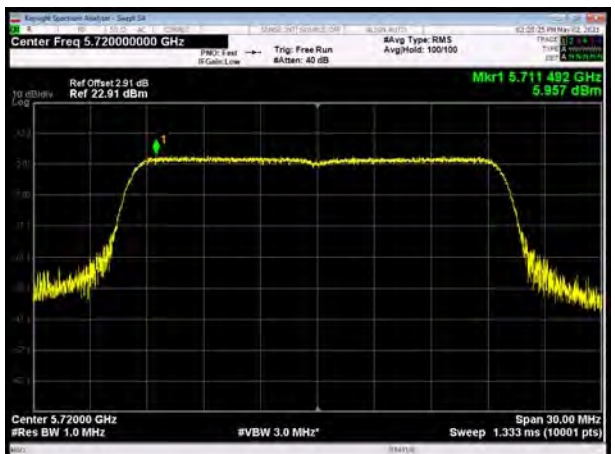

U-NII-2C, 802.11ax HE40 SU Mode 484-Tones,
Channel No.: 102

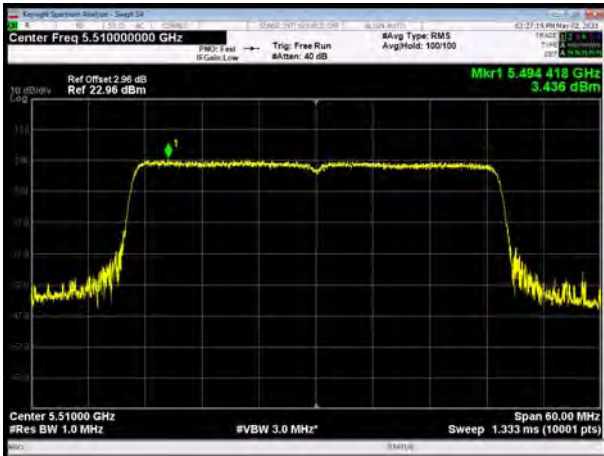

U-NII-2C, 802.11ax HE80 SU Mode 996-Tones,
Channel No.: 106

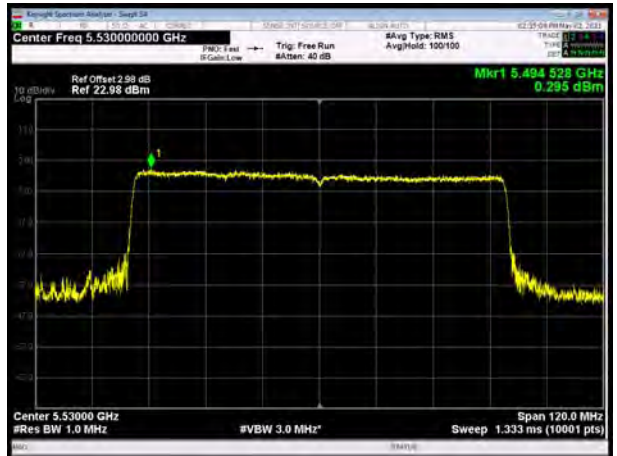

U-NII-2C, 802.11ax HE40 SU Mode 484-Tones,
Channel No.: 110

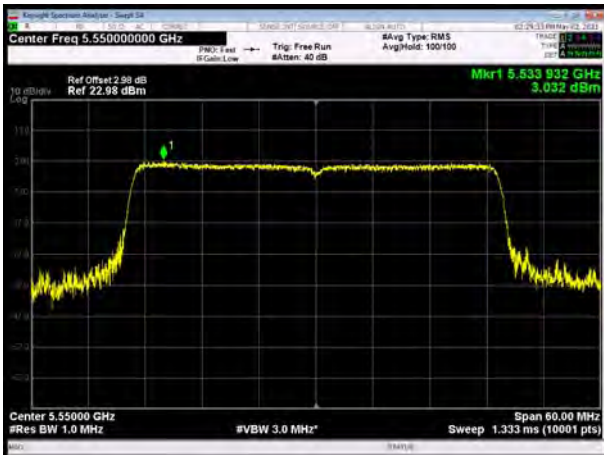

U-NII-2C, 802.11ax HE80 SU Mode 996-Tones,
Channel No.: 138

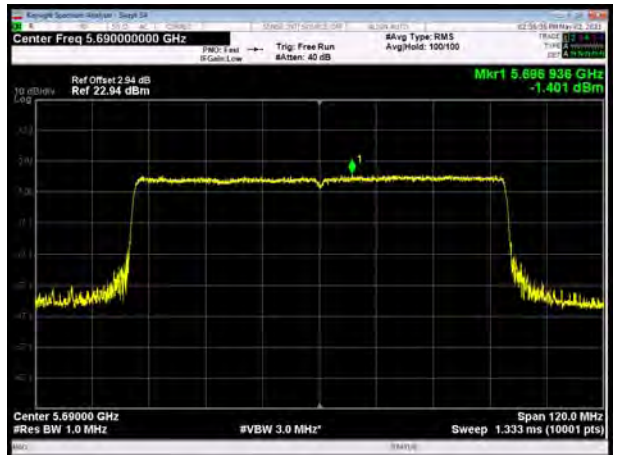

U-NII-2C, 802.11ax HE40 SU Mode 484-Tones,
Channel No.: 134

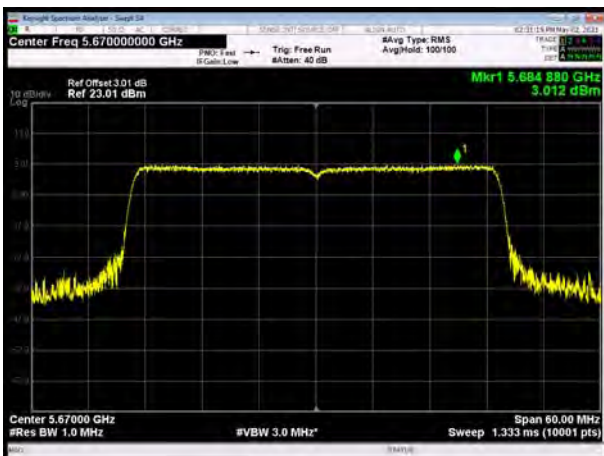

U-NII-2C, 802.11ax HE40 SU Mode 484-Tones,
Channel No.: 142

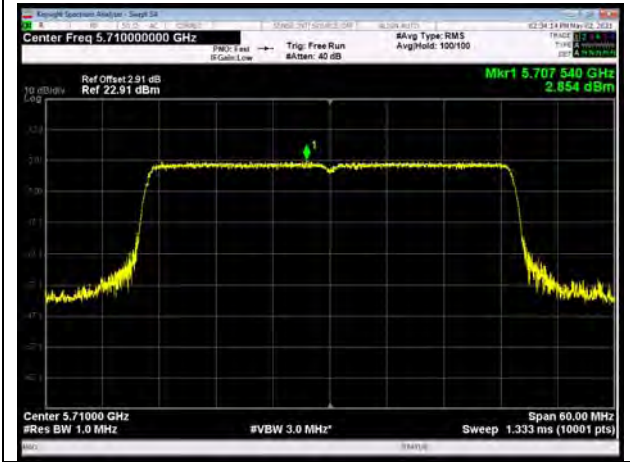

U-NII-3, 802.11n HT20, Channel No.: 149

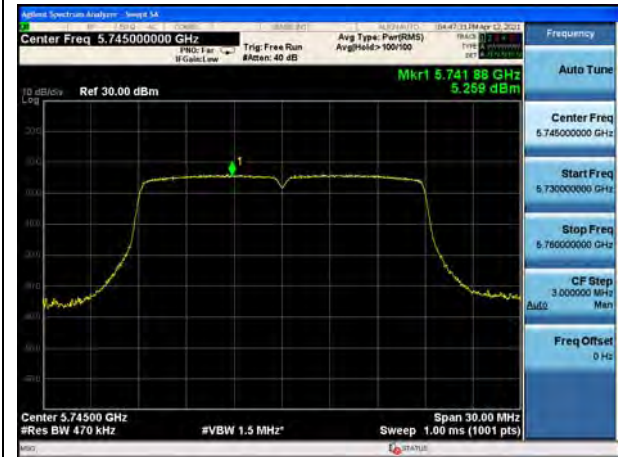

U-NII-3, 802.11n HT20, Channel No.: 157



U-NII-3, 802.11n HT20, Channel No.: 165



U-NII-3, 802.11n HT40, Channel No.: 151

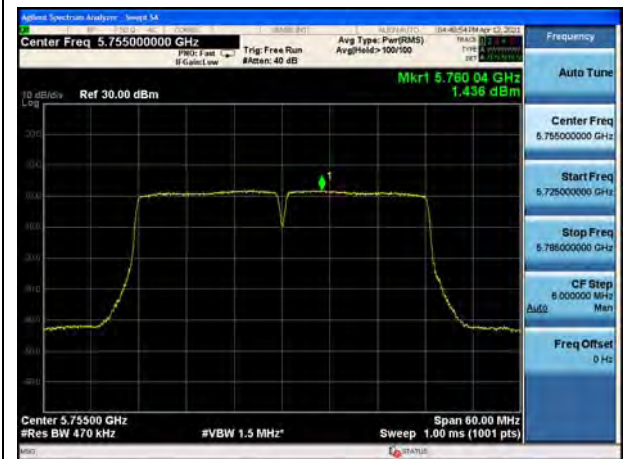

U-NII-3, 802.11ac VHT20, Channel No.: 149

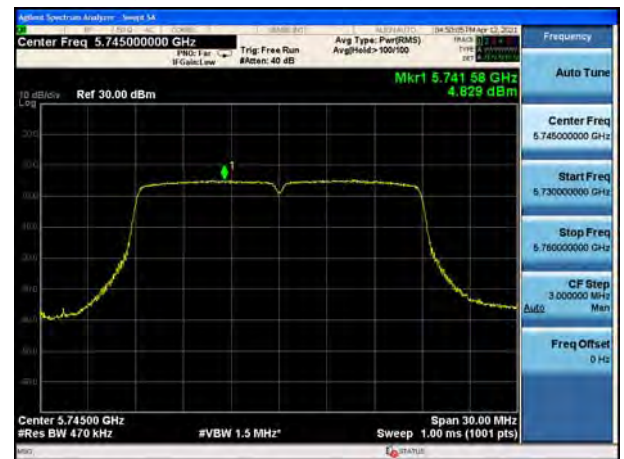

U-NII-3, 802.11n HT40, Channel No.: 159



U-NII-3, 802.11ac VHT20, Channel No.: 157

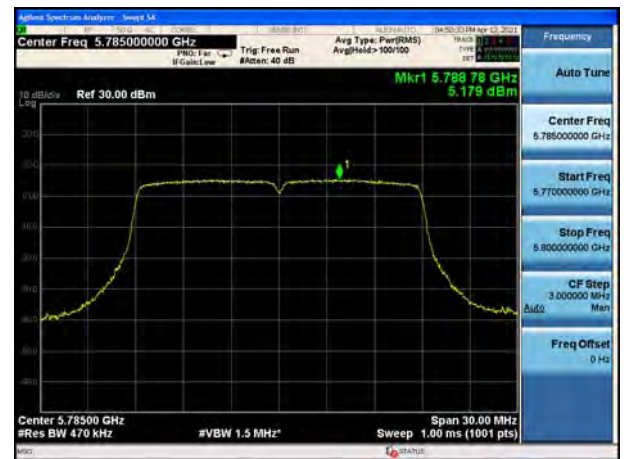

U-NII-3, 802.11ac VHT40, Channel No.: 151



U-NII-3, 802.11ac VHT20, Channel No.: 165

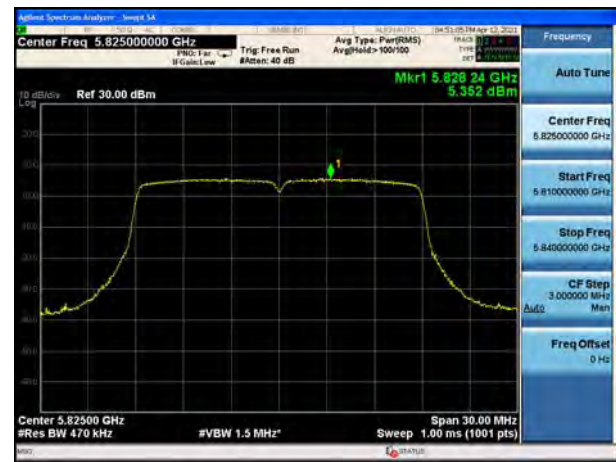

U-NII-3, 802.11ac VHT40, Channel No.: 159



U-NII-3, 802.11ac VHT80, Channel No.: 155



U-NII-3, 802.11ax HE20, Channel No.: 149



U-NII-3, 802.11ax HE40, Channel No.: 151

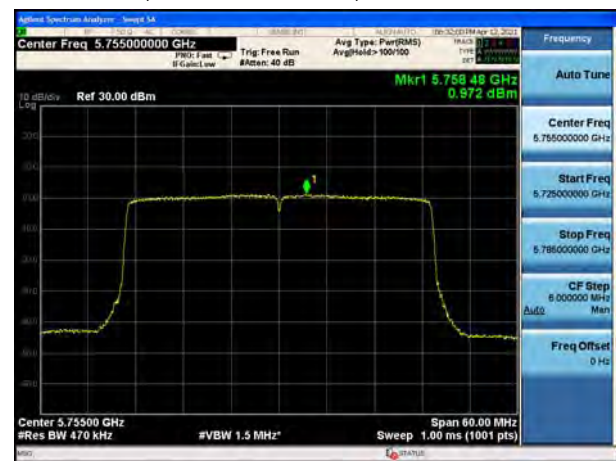

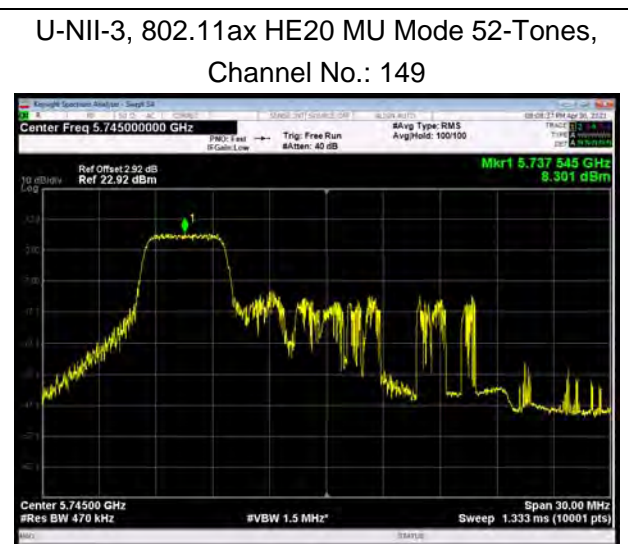
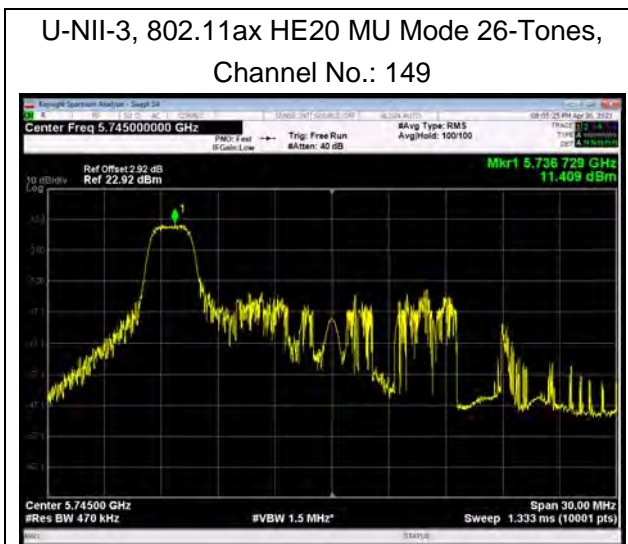
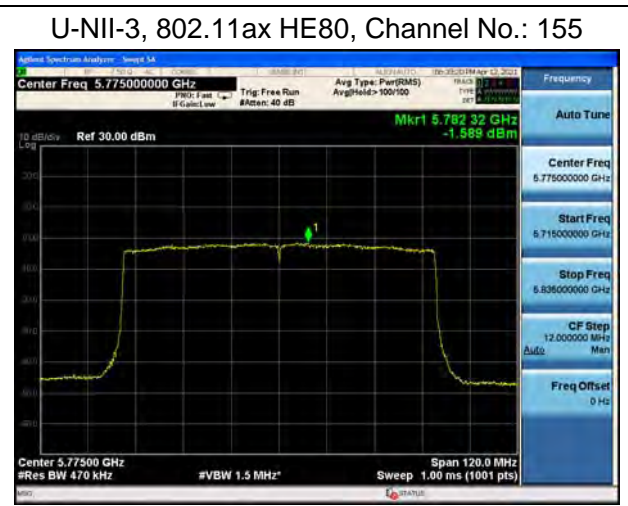
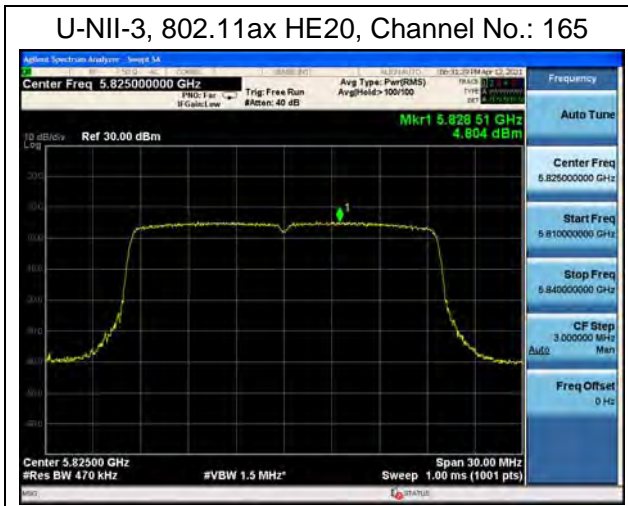
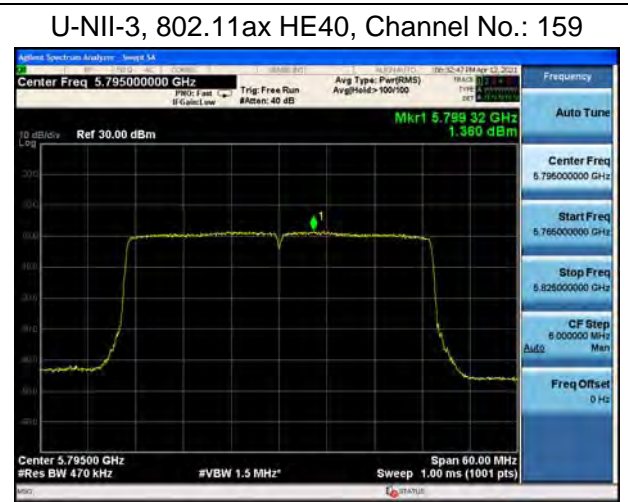
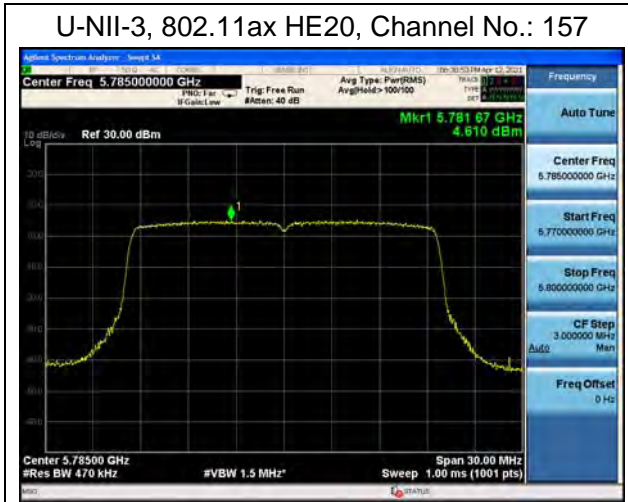

U-NII-3, 802.11ax HE20 MU Mode 26-Tones,
Channel No.: 157

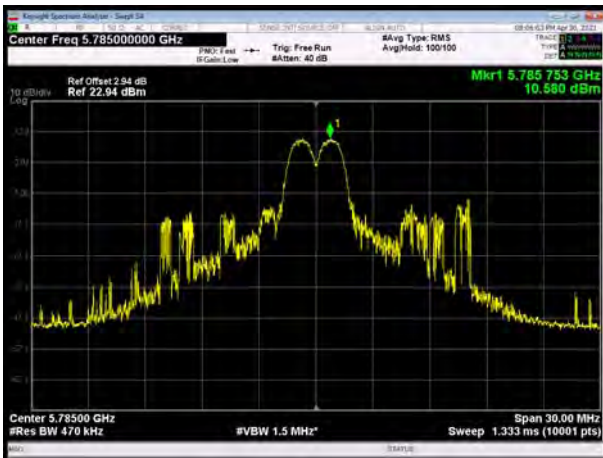

U-NII-3, 802.11ax HE20 MU Mode 52-Tones,
Channel No.: 157

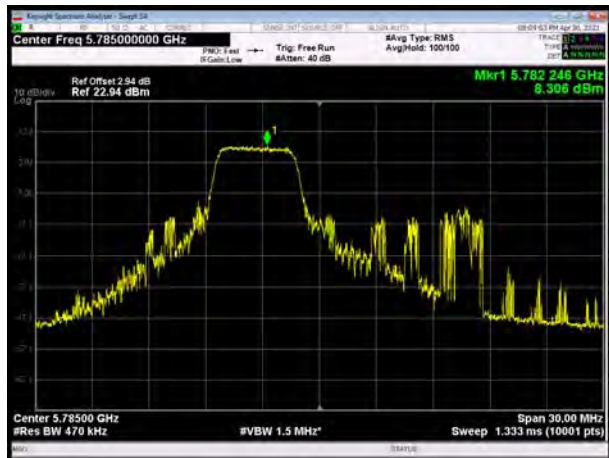

U-NII-3, 802.11ax HE20 MU Mode 26-Tones,
Channel No.: 165

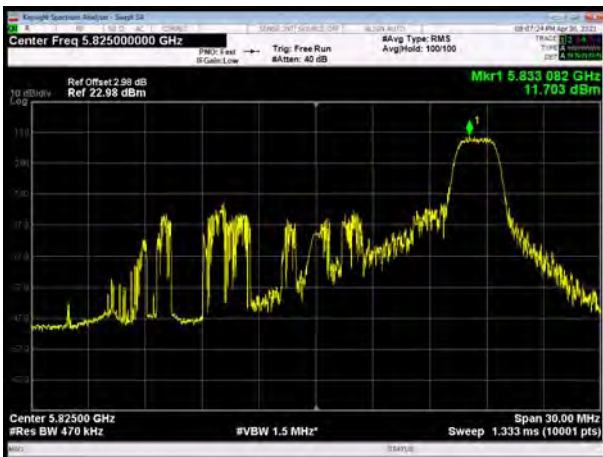

U-NII-3, 802.11ax HE20 MU Mode 52-Tones,
Channel No.: 165

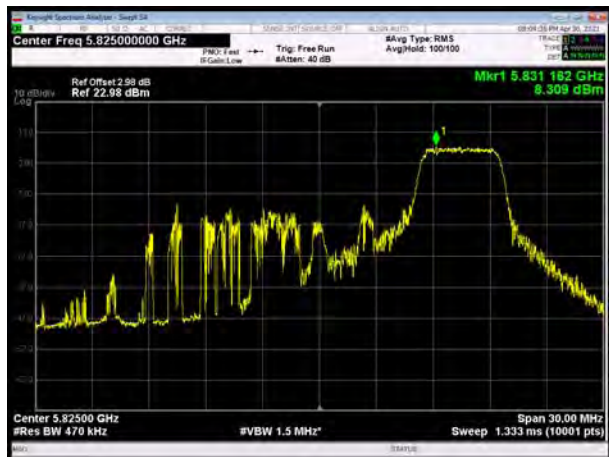

U-NII-3, 802.11ax HE20 MU Mode 106-Tones,
Channel No.: 149



U-NII-3, 802.11ax HE20 SU Mode 242-Tones,
Channel No.: 149

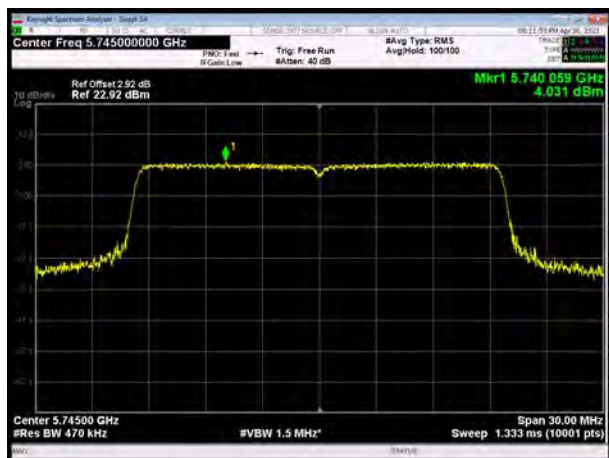

U-NII-3, 802.11ax HE20 MU Mode 106-Tones,
Channel No.: 157

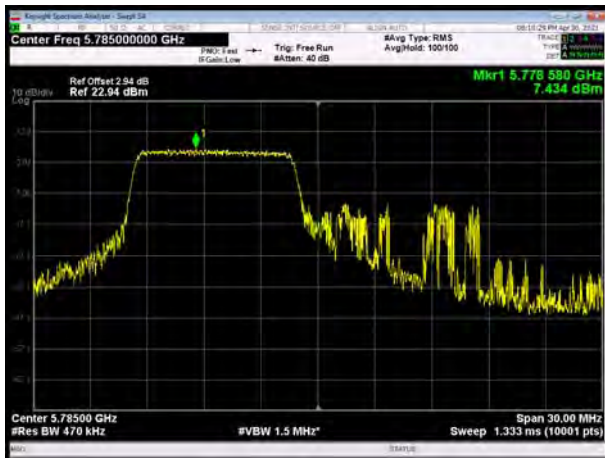

U-NII-3, 802.11ax HE20 SU Mode 242-Tones,
Channel No.: 157

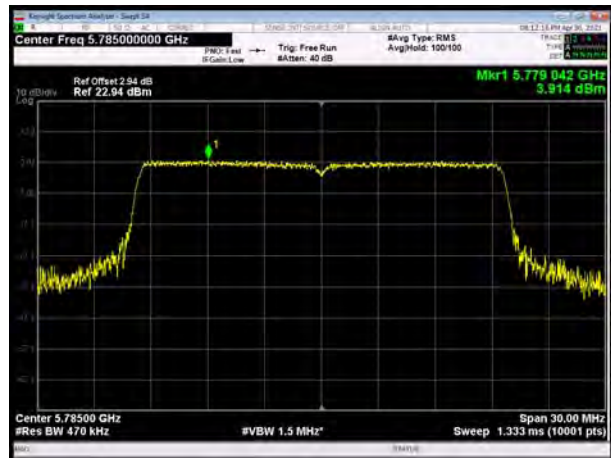

U-NII-3, 802.11ax HE20 MU Mode 106-Tones,
Channel No.:165

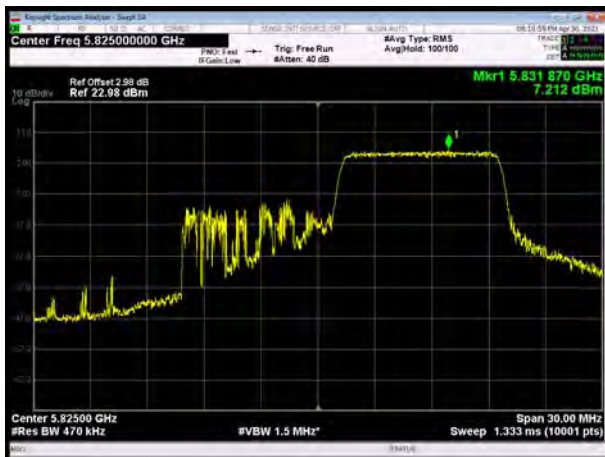

U-NII-3, 802.11ax HE20 SU Mode 242-Tones,
Channel No.: 165

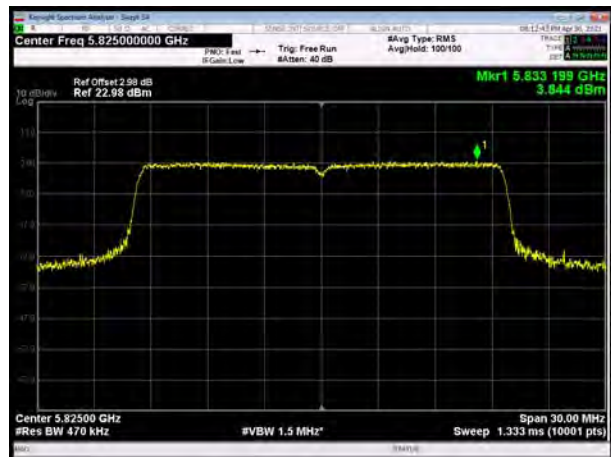

U-NII-3, 802.11ax HE40 SU Mode 484-Tones,
Channel No.: 151

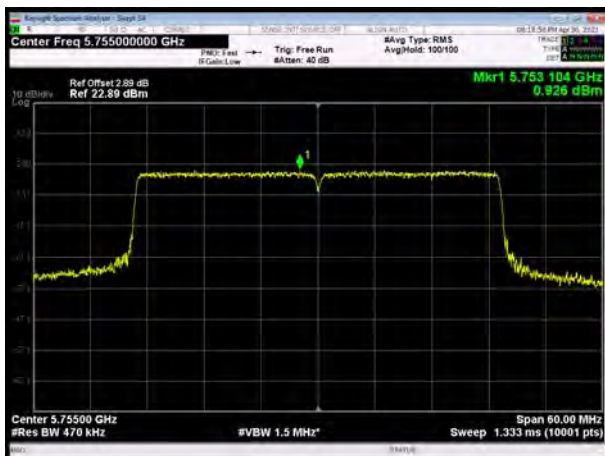

U-NII-3, 802.11ax HE80 SU Mode 996-Tones,
Channel No.: 155

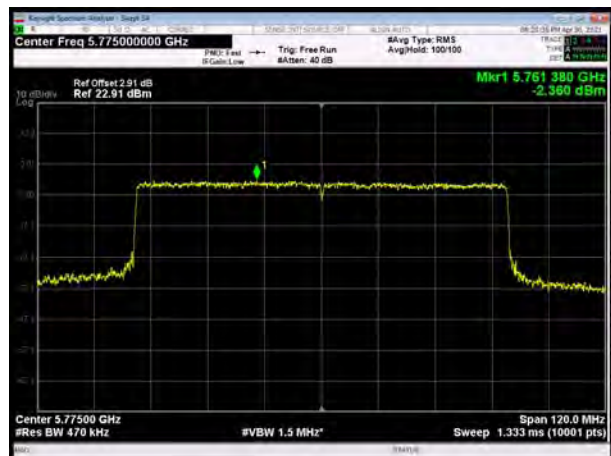

U-NII-3, 802.11ax HE40 SU Mode 484-Tones,
Channel No.: 159

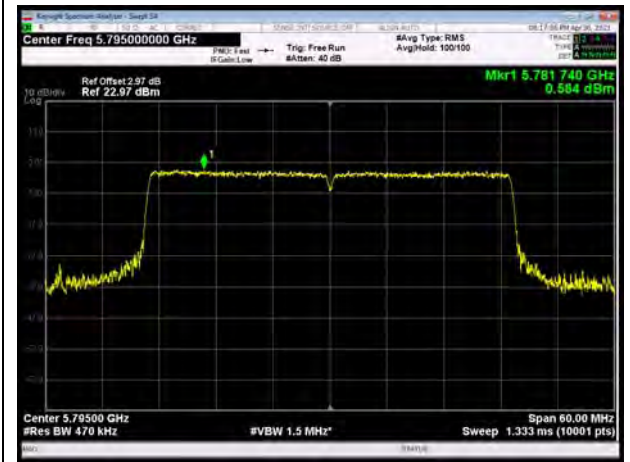

5.5. Unwanted Emission

Ambient condition

Temperature	Relative humidity	Pressure
23°C ~25°C	45%~50%	101.5kPa

Method of Measurement

The test set-up was made in accordance to the general provisions of ANSI C63.10. The Equipment Under Test (EUT) was set up on a non-conductive table in the semi-anechoic chamber. The test was performed at the distance of 3 m between the EUT and the receiving antenna. The radiated emissions measurements were made in a typical installation configuration.

Sweep the whole frequency band range from 9kHz to the 10th harmonic of the carrier, and the emissions less than 20 dB below the permissible value are reported.

During the test, the height of receive antenna shall be moved from 1 to 4 meters, and the antenna shall be performed under horizontal and vertical polarization. The turntable shall be rotated from 0 to 360 degrees for detecting the maximum of radiated spurious signal level. The measurements shall be repeated with orthogonal polarization of the test antenna. The data of cable loss and antenna factor has been calibrated in full testing frequency range before the testing.

Set the spectrum analyzer in the following:

9kHz~150 kHz

RBW=200Hz, VBW=1kHz/ Sweep=AUTO

150 kHz~30MHz

RBW=9KHz, VBW=30KHz,/ Sweep=AUTO

Below 1GHz

RBW=100kHz / VBW=300kHz / Sweep=AUTO

a) Peak emission levels are measured by setting the instrument as follows:

Above 1GHz

PEAK: RBW=1MHz VBW=3MHz/ Sweep=AUTO

b) Average emission levels are measured by setting the instrument as follows:

Above 1GHz

AVERAGE: RBW=1MHz / VBW=3MHz / Sweep=AUTO

c) Detector: The measurements employing a CISPR quasi-peak detector except for the frequency bands 9-90 kHz, 110-490 kHz and above 1000 MHz. Radiated emission limits in these three bands are based on measurements employing an average detector.

d) Averaging type = power (i.e., rms) (As an alternative, the detector and averaging type may be set for linear voltage averaging. Some instruments require linear display mode to use linear voltage averaging. Log or dB averaging shall not be used.)

e) Sweep time = auto.

f) Perform a trace average of at least 100 traces if the transmission is continuous. If the transmission is not continuous, then the number of traces shall be increased by a factor of $1 / D$, where D is the duty cycle. For example, with 50% duty cycle, at least 200 traces shall be averaged. (If a specific



emission is demonstrated to be continuous—i.e., 100% duty cycle—then rather than turning ON and OFF with the transmit cycle, at least 100 traces shall be averaged.)

g) If tests are performed with the EUT transmitting at a duty cycle less than 98%, then a correction factor shall be added to the measurement results prior to comparing with the emission limit, to compute the emission level that would have been measured had the test been performed at 100% duty cycle. The correction factor is computed as follows:

1) If power averaging (rms) mode was used in the preceding step e), then the correction factor is $[10 \log (1 / D)]$, where D is the duty cycle. For example, if the transmit duty cycle was 50%, then 3 dB shall be added to the measured emission levels.

2) If linear voltage averaging mode was used in the preceding step e), then the correction factor is $[20 \log (1 / D)]$, where D is the duty cycle. For example, if the transmit duty cycle was 50%, then 6 dB shall be added to the measured emission levels.

3) If a specific emission is demonstrated to be continuous (100% duty cycle) rather than turning ON and OFF with the transmit cycle, then no duty cycle correction is required for that emission.

Reduce the video bandwidth until no significant variations in the displayed signal are observed in subsequent traces, provided the video bandwidth is no less than 1 Hz. For regulatory requirements that specify averaging only over the transmit duration (e.g., digital transmission system [DTS] and Unlicensed National Information Infrastructure [U-NII]), the video bandwidth shall be greater than $[1 / (\text{minimum transmitter on time})]$ and no less than 1 Hz.

The field strength of spurious emission was measured in the following position: EUT stand-up position (Z axis), lie-down position (X, Y axis). The worst emission was found in stand-up position (Z axis) and the loop antenna is vertical, others antenna are vertical and horizontal.

The test is in transmitting mode.

9KHz~~~30MHz

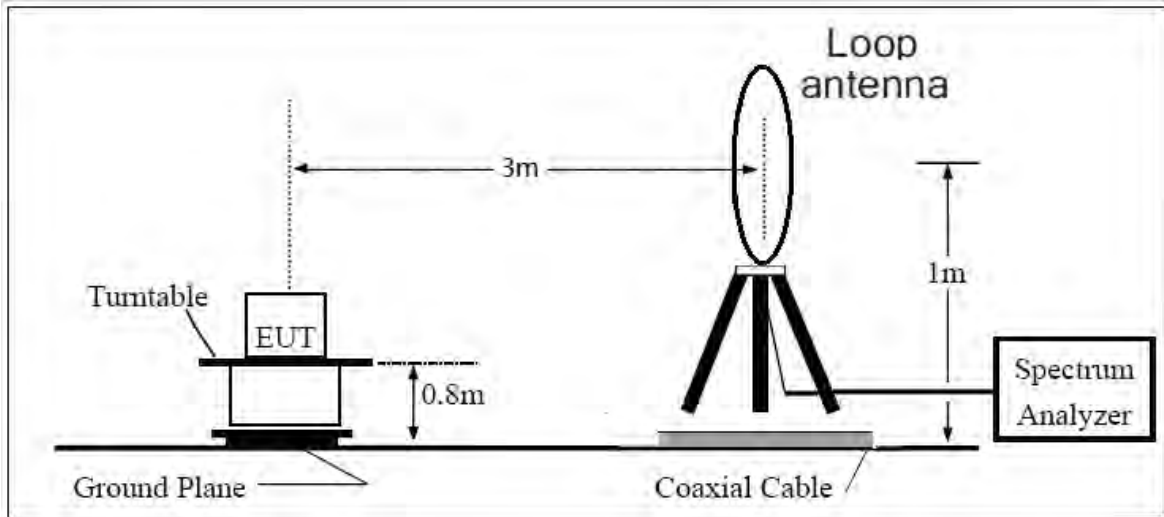

30MHz~~~ 1GHz

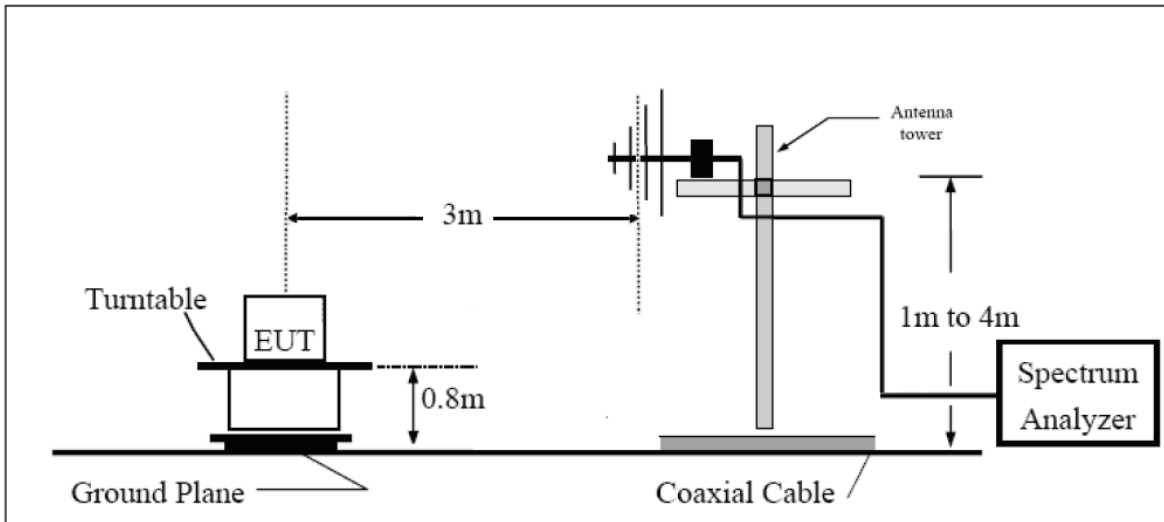

Above 1GHz

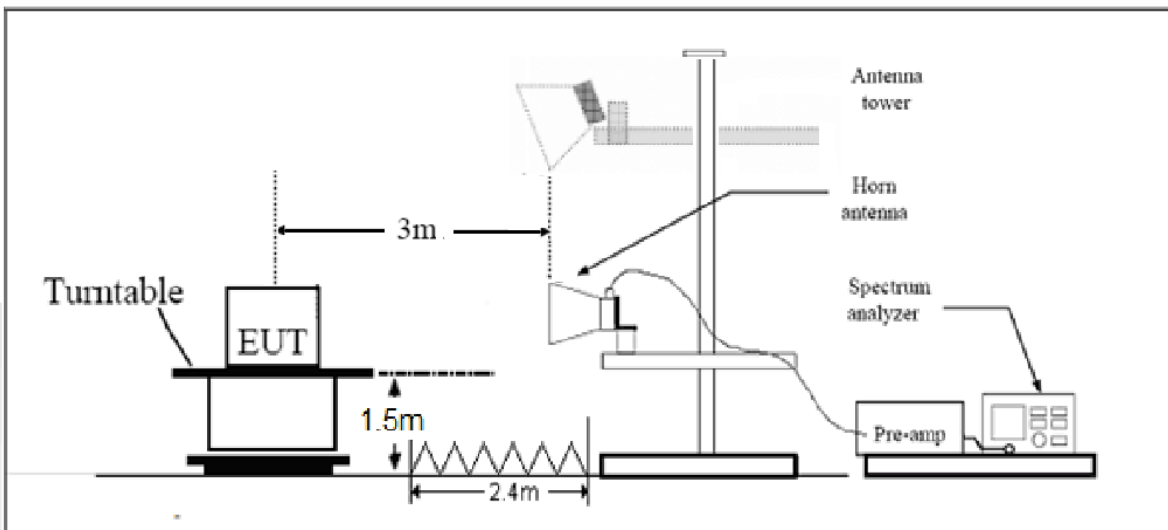

Note: Area side:2.4mX3.6m

**Limits**

- (1) For transmitters operating in the 5725-5850 MHz band: All emissions shall be limited to a level of -27 dBm/MHz at 75 MHz or more above or below the band edge increasing linearly to 10 dBm/MHz at 25 MHz above or below the band edge, and from 25 MHz above or below the band edge increasing linearly to a level of 15.6 dBm/MHz at 5 MHz above or below the band edge, and from 5 MHz above or below the band edge increasing linearly to a level of 27 dBm/MHz at the band edge.
- (2) For transmitters operating in the 5.15-5.25 GHz band: All emissions outside of the 5.15-5.35 GHz band shall not exceed an e.i.r.p. of -27 dBm/MHz(68.2dBμV/m).
- (3) For transmitters operating in the 5.25-5.35 GHz band: All emissions outside of the 5.15-5.35 GHz band shall not exceed an e.i.r.p. of -27 dBm/MHz(68.2dBμV/m).
- (4) For transmitters operating in the 5.47-5.725 GHz band: All emissions outside of the 5.47-5.725 GHz band shall not exceed an e.i.r.p. of -27 dBm/MHz(68.2dBμV/m).

Note: the following formula is used to convert the EIRP to field strength

§1、 $E[\text{dB}\mu\text{V}/\text{m}] = \text{EIRP}[\text{dBm}] - 20 \log(d[\text{meters}]) + 104.77$, where E = field strength and

d = distance at which field strength limit is specified in the rules;

§2、 $E[\text{dB}\mu\text{V}/\text{m}] = \text{EIRP}[\text{dBm}] + 95.2$, for d = 3 meters

- (5) Unwanted spurious emissions fallen in restricted bands per FCC Part15.205 shall comply with the general field strength limits set forth in § 15.209 as below table.

Frequency of emission (MHz)	Field strength(uV/m)	Field strength(dBuV/m)
0.009–0.490	2400/F(kHz)	/
0.490–1.705	24000/F(kHz)	/
1.705–30.0	30	/
30-88	100	40
88-216	150	43.5
216-960	200	46
Above960	500	54



MHz	MHz	MHz	GHz
0.090 - 0.110	16.42 - 16.423	399.9 - 410	4.5 - 5.15
0.495 - 0.505	16.69475 - 16.69525	608 - 614	5.35 - 5.46
2.1735 - 2.1905	16.80425 - 16.80475	960 - 1240	7.25 - 7.75
4.125 - 4.128	25.5 - 25.67	1300 - 1427	8.025 - 8.5
4.17725 - 4.17775	37.5 - 38.25	1435 - 1626.5	9.0 - 9.2
4.20725 - 4.20775	73 - 74.6	1645.5 - 1646.5	9.3 - 9.5
6.215 - 6.218	74.8 - 75.2	1660 - 1710	10.6 - 12.7
6.26775 - 6.26825	108 - 121.94	1718.8 - 1722.2	13.25 - 13.4
6.31175 - 6.31225	123 - 138	2200 - 2300	14.47 - 14.5
8.291 - 8.294	149.9 - 150.05	2310 - 2390	15.35 - 16.2
8.362 - 8.366	156.52475 - 156.52525	2483.5 - 2500	17.7 - 21.4
8.37625 - 8.38675	156.7 - 156.9	2690 - 2900	22.01 - 23.12
8.41425 - 8.41475	162.0125 - 167.17	3260 - 3267	23.6 - 24.0
12.29 - 12.293	167.72 - 173.2	3332 - 3339	31.2 - 31.8
12.51975 - 12.52025	240 - 285	3345.8 - 3358	36.43 - 36.5
12.57675 - 12.57725	322 - 335.4	3600 - 4400	(²)
13.36 - 13.41			

Measurement Uncertainty

The assessed measurement uncertainty to ensure 95% confidence level for the normal distribution is with the coverage factor $k = 1.96$.

Frequency	Uncertainty
9KHz-30MHz	3.55 dB
30MHz-200MHz	4.17 dB
200MHz-1GHz	4.84 dB
1-18GHz	4.35 dB
18-26.5GHz	5.90 dB
26.5GHz~40GHz	5.92 dB



Test Results:

The modulation and bandwidth are similar for 802.11n mode for 20MHz/40MHz and 802.11ac mode for V20MHz/V40MHz, therefore investigated worst case to representative mode in test report.

The signal beyond the limit is carrier.

U-NII-1

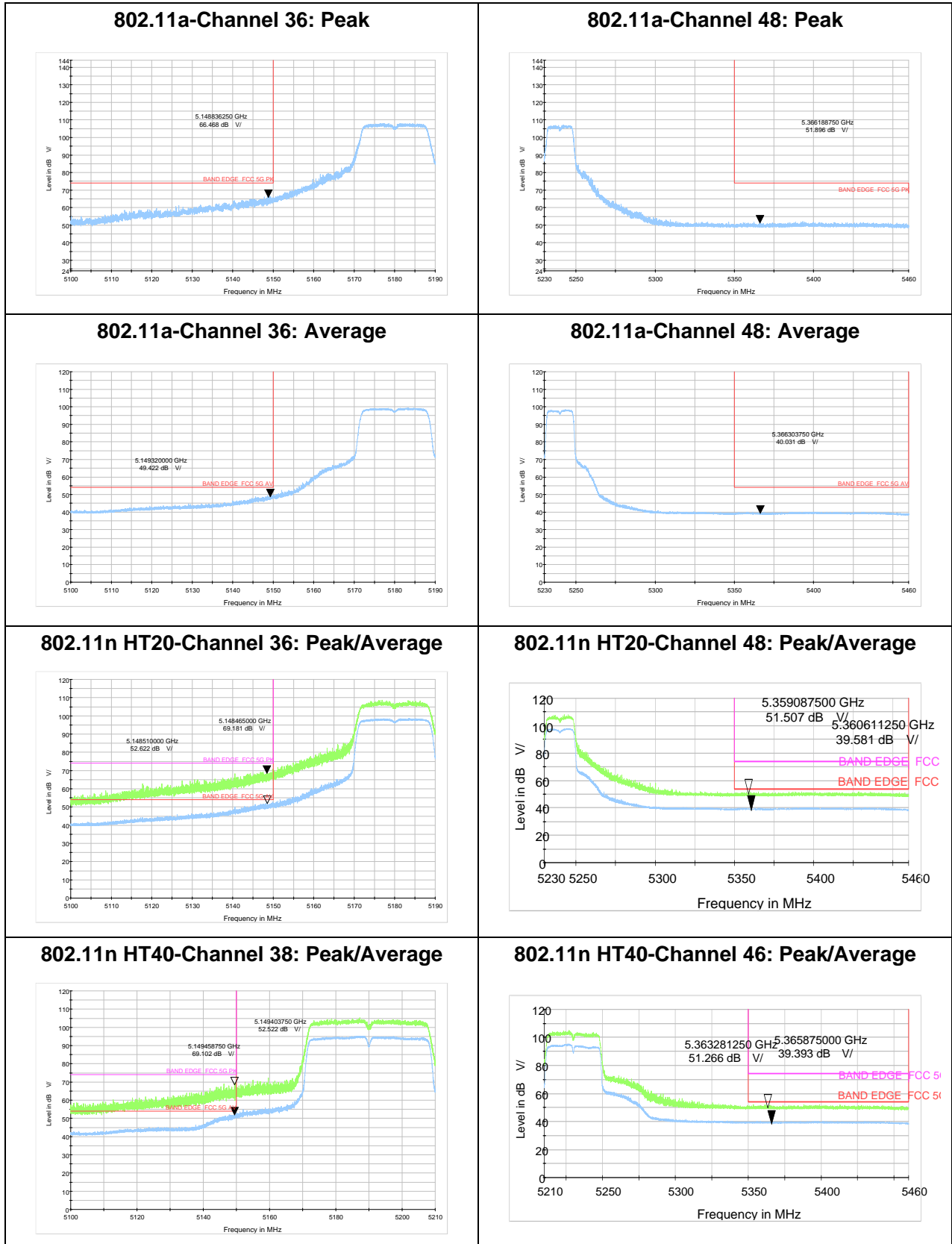



802.11ac VHT80 –Channel 42: Peak/Average

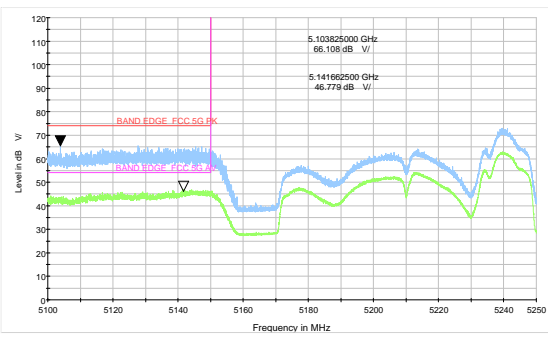

802.11ax HE20-Channel 36: Peak/Average

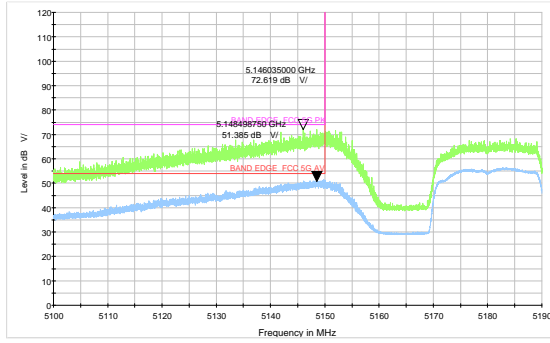

802.11ax HE20-Channel 48: Peak/Average

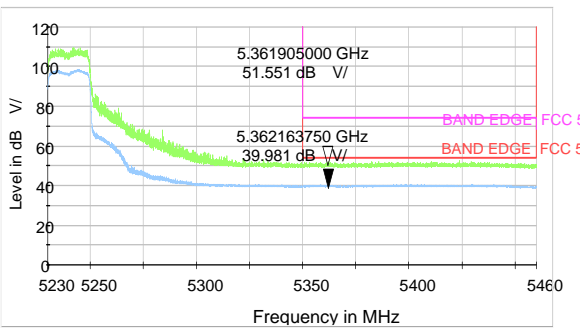

802.11ax HE40-Channel 38: Peak/Average

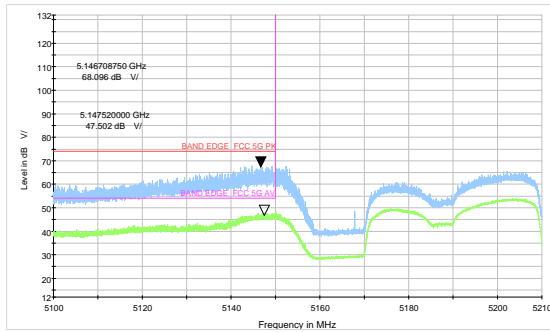

802.11ax HE40-Channel 46: Peak/Average

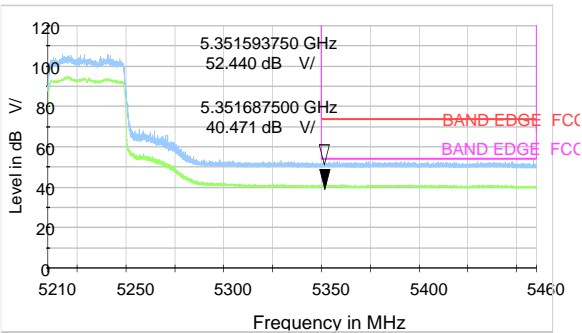

802.11ax HE80-Channel 42: Peak/Average

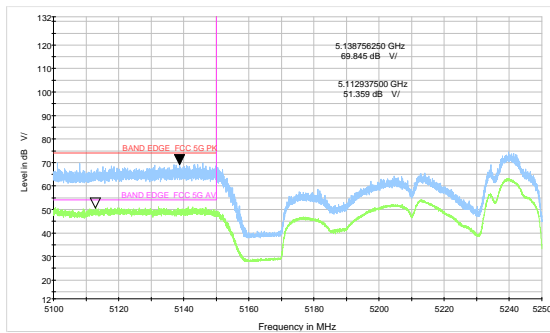

U-NII-2A

802.11a-Channel 52: Peak

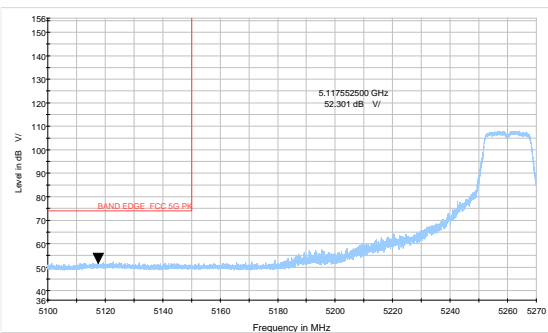

802.11a-Channel 64: Peak

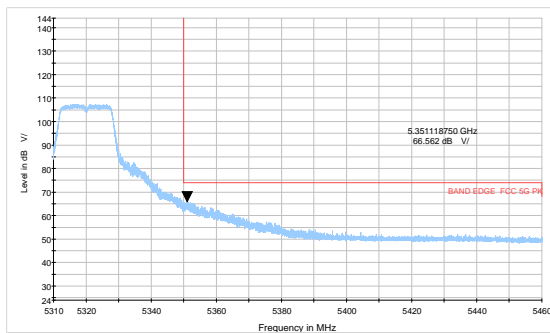



802.11a-Channel 52: Average

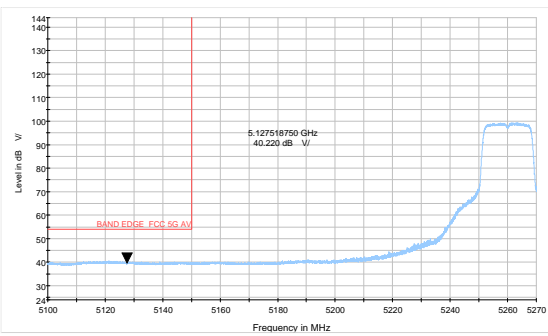

802.11a-Channel 64: Average

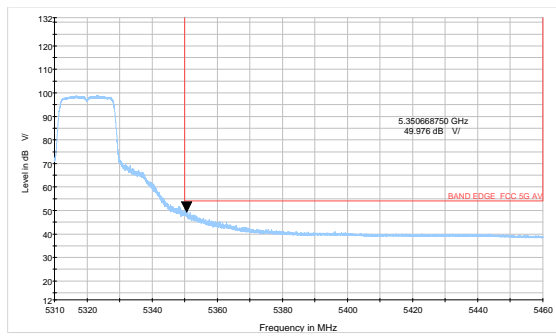

802.11n HT20-Channel 52: Peak/Average

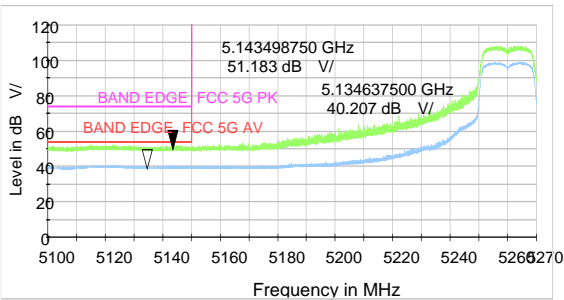

802.11n HT20-Channel 64: Peak/Average

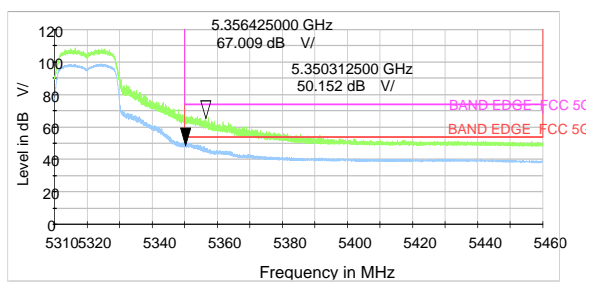

802.11n HT40-Channel 54: Peak/Average

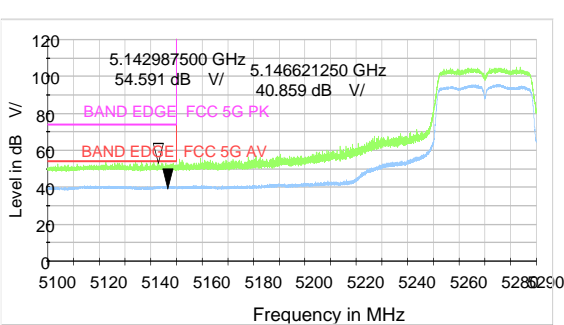

802.11n HT40-Channel 62: Peak/Average

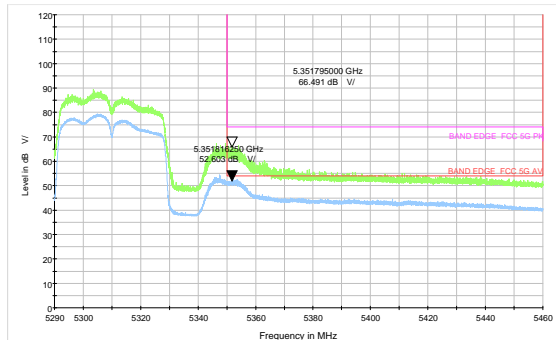

802.11ac VHT80 -Channel 58: Peak/Average

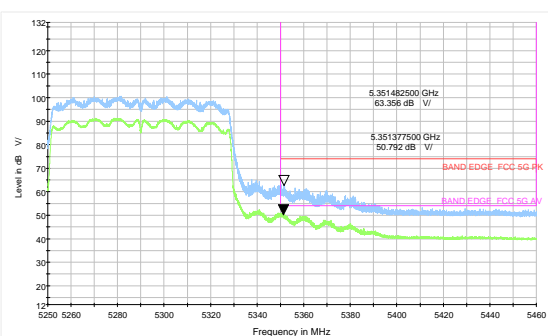

802.11ax HE20-Channel 52: Peak/Average

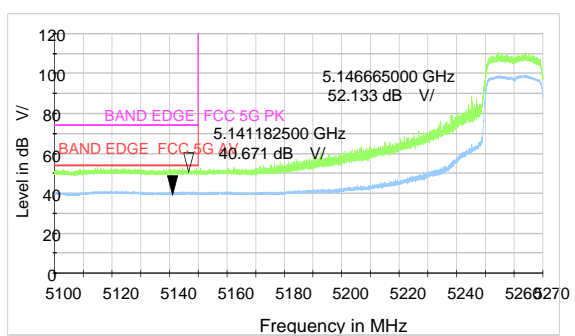



802.11ax HE20-Channel 64: Peak/Average

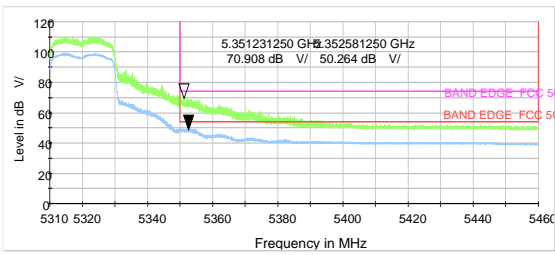

802.11ax HE40-Channel 54: Peak/Average

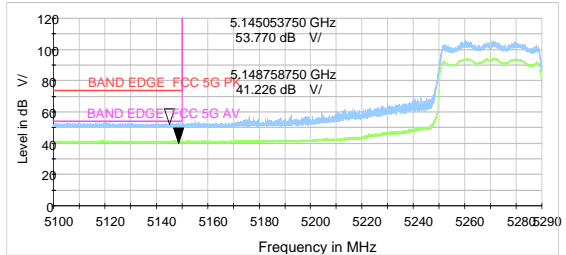

802.11ax HE40-Channel 62: Peak/Average

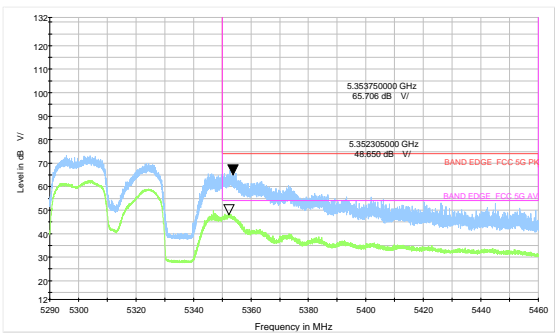

802.11ax HE80-Channel 58: Peak/Average

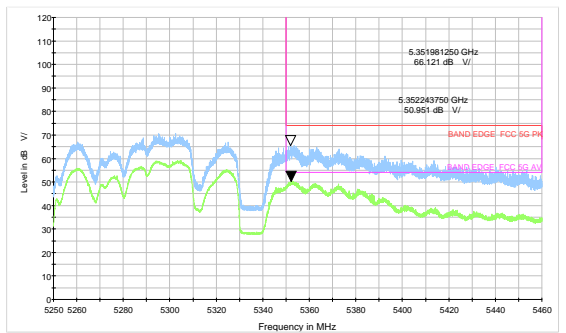

U-NII-2C

802.11a-Channel 100: Peak

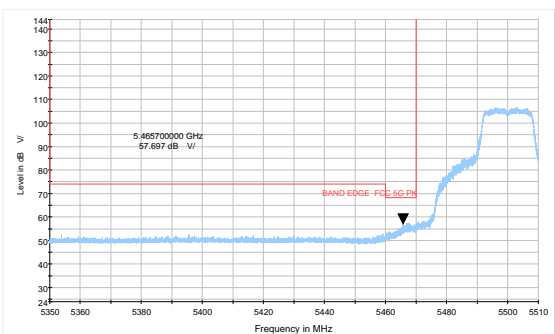

802.11n HT20-Channel 100: Peak/ Average

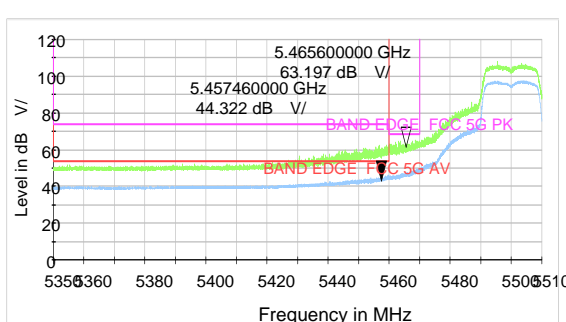

802.11a-Channel 100: Average

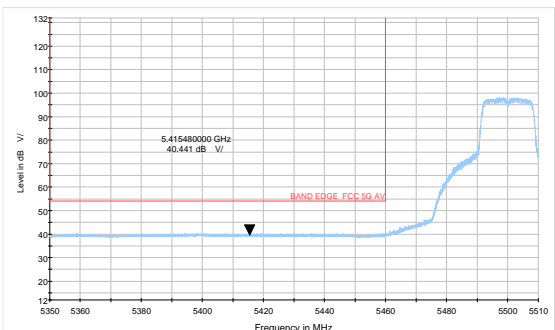

802.11n HT20-Channel 140: Peak

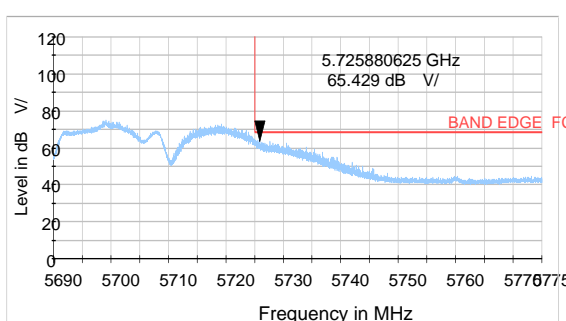



802.11a-Channel 140: Peak

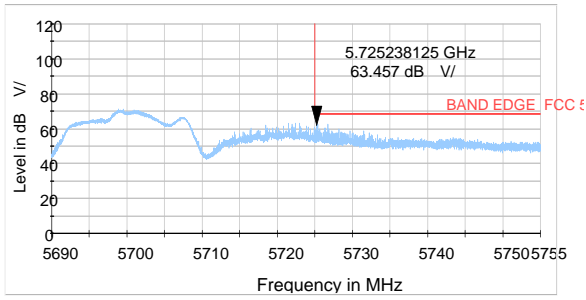

802.11n HT40-Channel 102: Peak/ Average

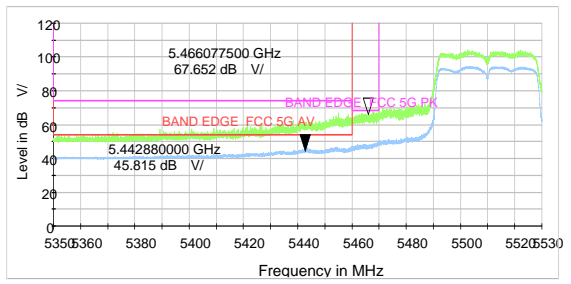

802.11ac VHT80-Channel 106: Peak/ Average

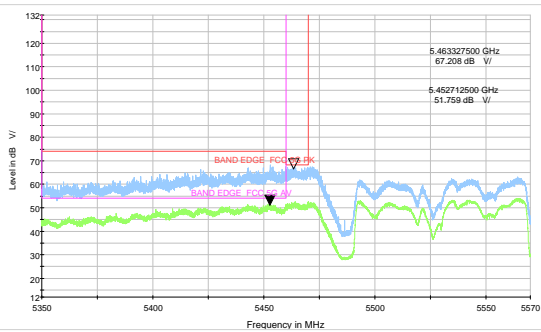

802.11n HT40-Channel 134: Peak

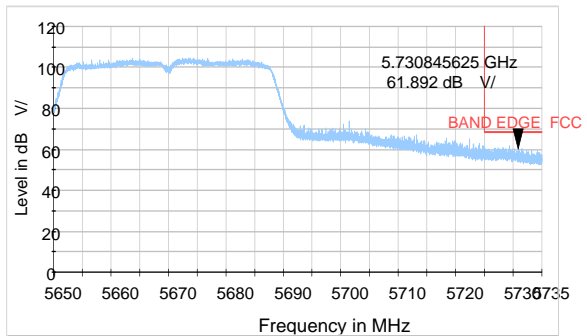

802.11ax HE20-Channel 100: Peak/ Average

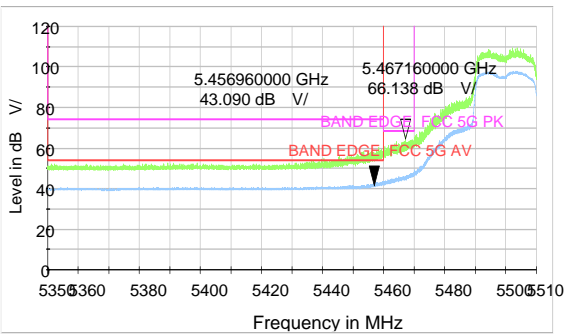

802.11ax HE20-Channel 140: Peak

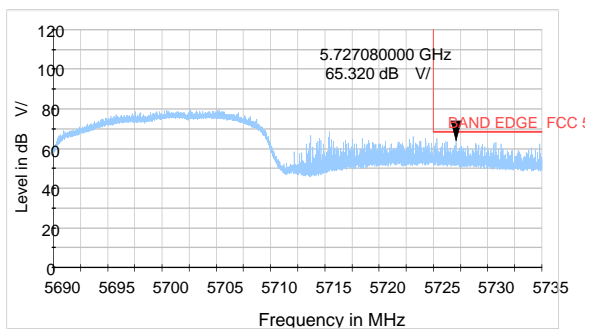

802.11ax HE40-Channel 102: Peak/ Average

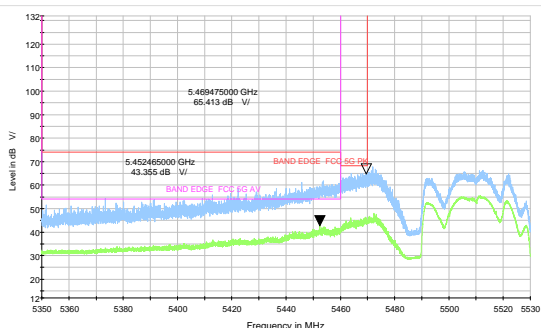

802.11ax HE40-Channel 134: Peak

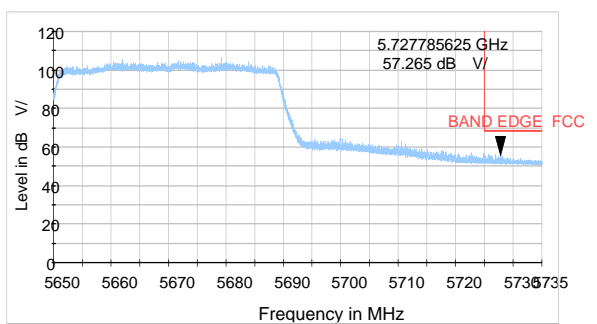



802.11ax HE80-Channel 106: Peak/ Average

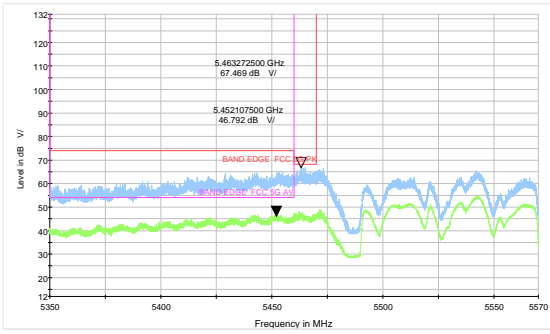

U-NII-3

802.11a-Channel 149: Peak

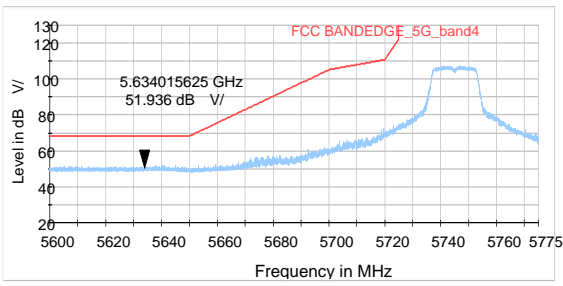

802.11a-Channel 165: Peak

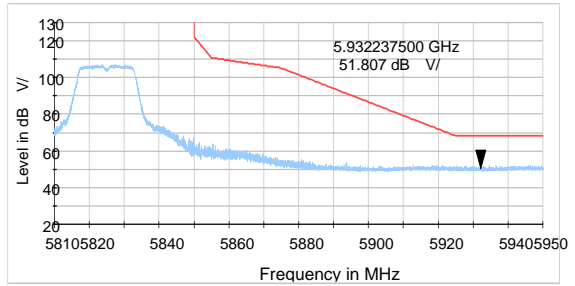

802.11n HT20-Channel 149: Peak

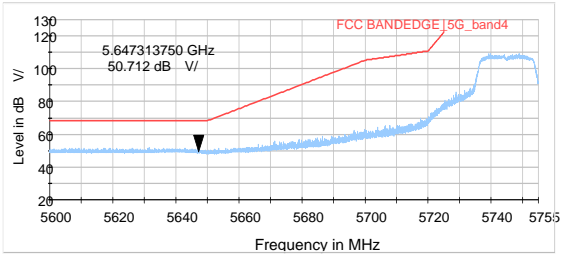

802.11n HT20-Channel 165: Peak

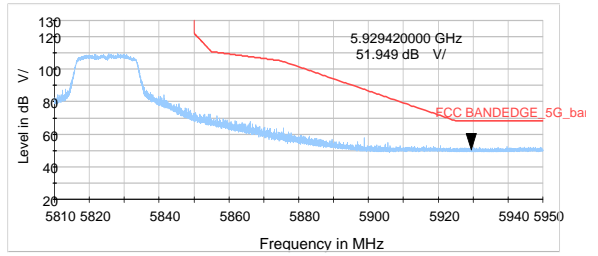

802.11n HT40-Channel 151: Peak

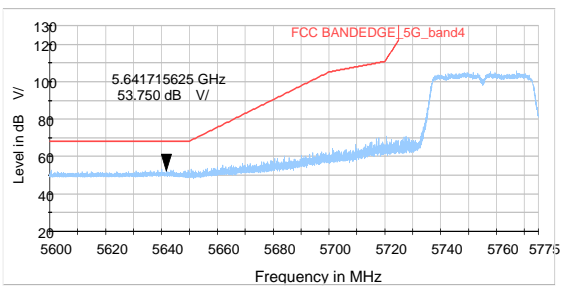

802.11n HT40-Channel 159: Peak

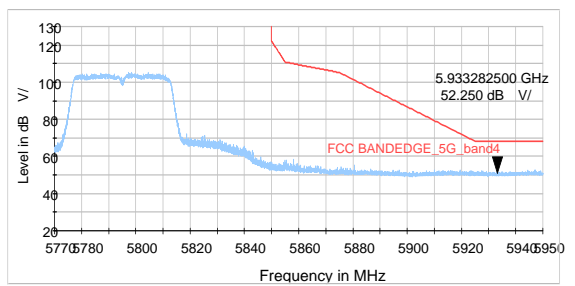



802.11ac VHT80- Channel 155: Peak

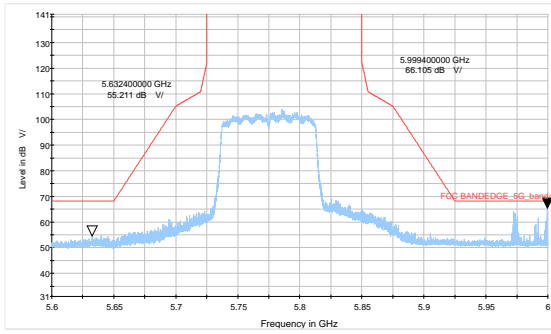

802.11ax HE20-Channel 149: Peak

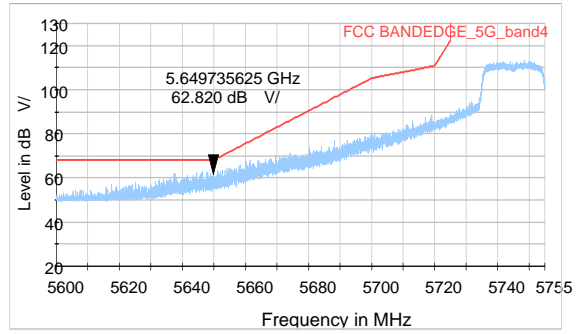

802.11ax HE20-Channel 165: Peak

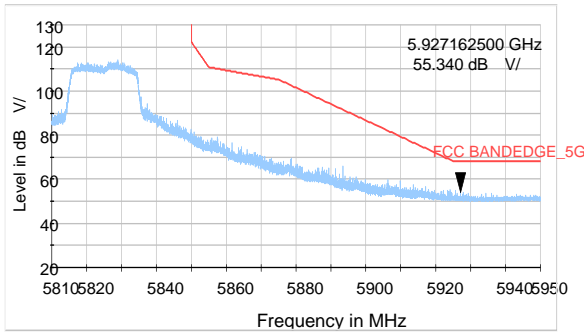

802.11ax HE40-Channel 151: Peak

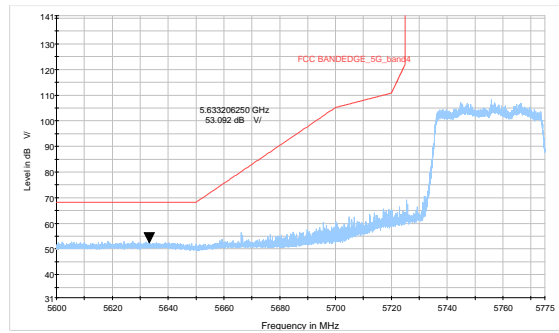

802.11ax HE40-Channel 159: Peak

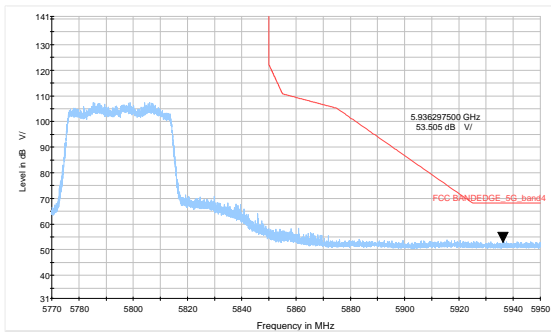

802.11ax HE80- Channel 155: Peak

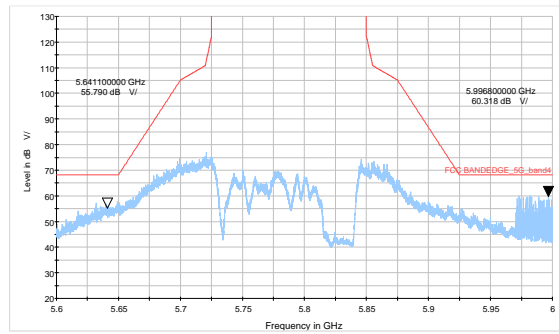

Result of RE

Test result

Sweep the whole frequency band through the range from 9kHz to the 10th harmonic of the carrier, the Emissions in the frequency band 9kHz-30MHz and 26.5GHz-40GHz are more than 20dB below the limit are not reported.

After the pretest, MIMO was selected as the worst antenna for 802.11n HT20/40, 802.11ac VHT20/40/80, 802.11ax HE20/HE40/HE80. SISO Antenna 1 was selected as the worst SISO antenna for 802.11a.

During the test, the Radiates Emission from 30MHz to 1GHz was performed in all modes with all channels, 802.11ax HE20 Channel 36 are selected as the worst condition. The test data of the worst-case condition was recorded in this report.

Continuous TX mode:

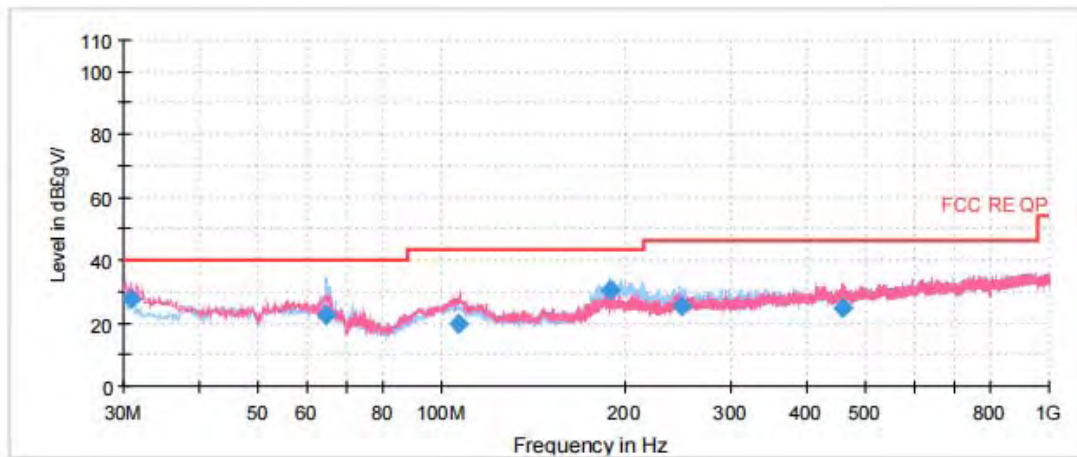

Radiates Emission from 30MHz to 1GHz

Frequency (MHz)	Quasi-Peak (dBuV/m)	Limit (dBuV/m)	Margin (dB)	Height (cm)	Polarization	Azimuth (deg)	Correct Factor (dB)
30.842500	27.68	40.00	12.32	121.0	V	298.0	-4.5
64.717500	22.78	40.00	17.22	225.0	H	255.0	-6.9
106.636250	19.89	43.50	23.61	109.0	V	259.0	-5.8
189.165000	30.18	43.50	13.32	175.0	H	280.0	-6.4
249.588750	25.51	46.00	20.49	125.0	H	270.0	-4.4
456.037500	24.76	46.00	21.24	220.0	V	70.0	-0.4

Remark: 1. Correction Factor = Antenna factor+ Insertion loss(cable loss+amplifier gain)

2. Margin = Limit – Quasi-Peak

802.11a CH36

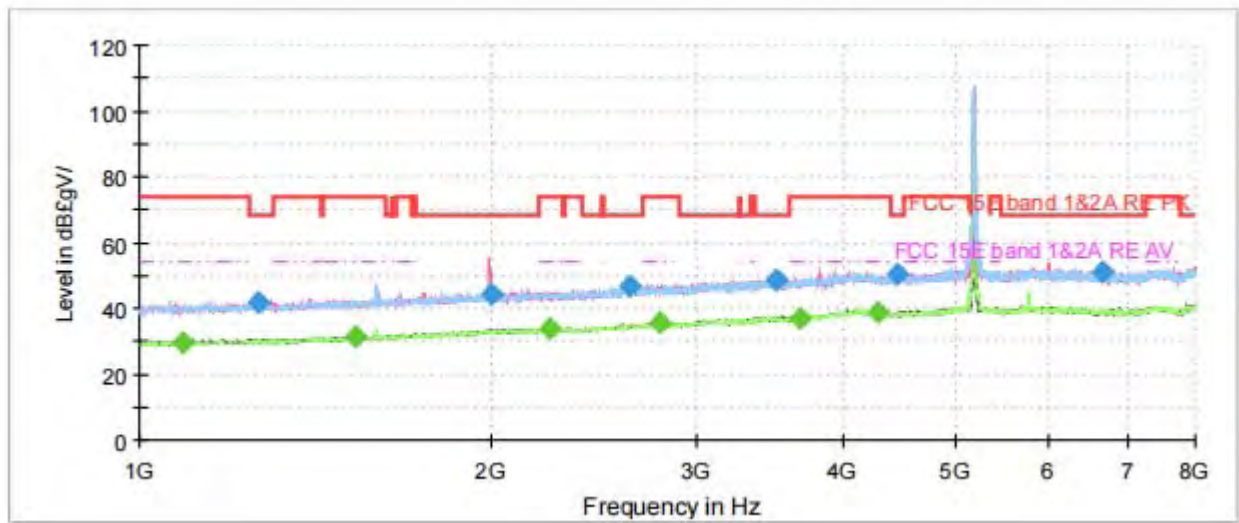

Note: The signal beyond the limit is carrier.
Radiates Emission from 1GHz to 8GHz

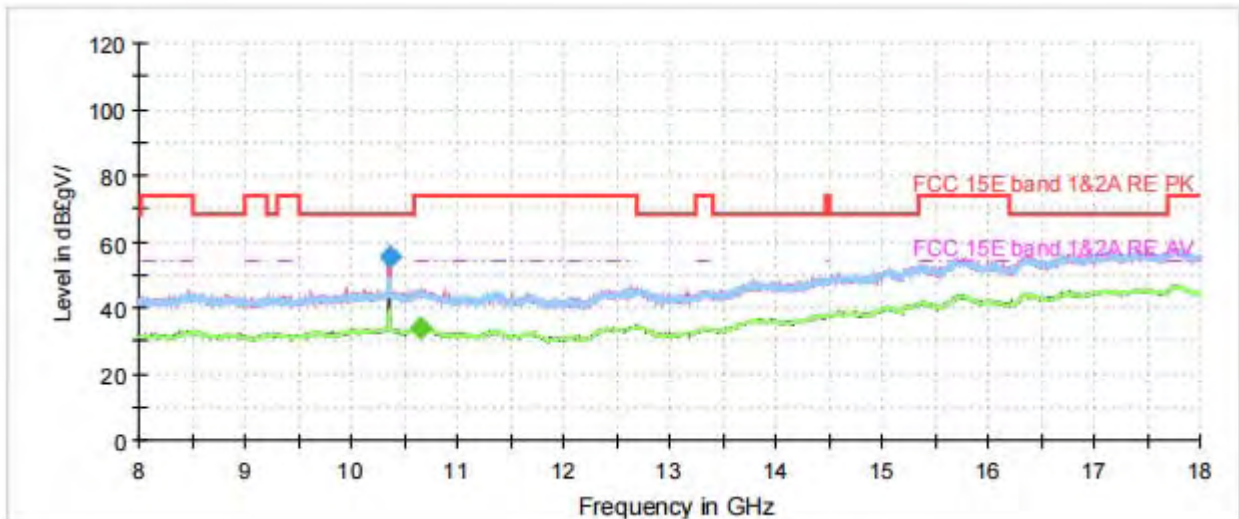

Radiates Emission from 8GHz to 18GHz



Frequency (MHz)	Peak (dBuV/m)	Average (dBuV/m)	Limit (dBuV/m)	Margin (dB)	Height (cm)	Polarization	Azimuth (deg)	Correct Factor (dB)
1088.375000	---	29.48	54.00	24.52	200.0	V	42.0	-7.9
1261.625000	41.77	---	68.20	26.43	200.0	V	293.0	-6.9
1530.250000	---	31.13	54.00	22.87	100.0	V	349.0	-5.4
2003.625000	44.04	---	68.20	24.16	100.0	V	7.0	-2.6
2241.625000	---	33.80	54.00	20.20	200.0	H	132.0	-1.7
2630.125000	47.01	---	68.20	21.19	200.0	H	330.0	0.2
2785.000000	---	35.40	54.00	18.60	100.0	H	229.0	0.9
3504.250000	48.58	---	68.20	19.62	100.0	H	35.0	3.7
3674.000000	---	37.10	54.00	16.90	200.0	V	30.0	4.4
4278.625000	---	38.91	54.00	15.09	100.0	V	241.0	6.2
4447.500000	50.49	---	68.20	17.71	200.0	H	174.0	6.3
6658.625000	51.00	---	68.20	17.21	100.0	V	203.0	10.4

Remark: 1. Correction Factor = Antenna factor+ Insertion loss (cable loss + amplifier gain)

802.11a CH40

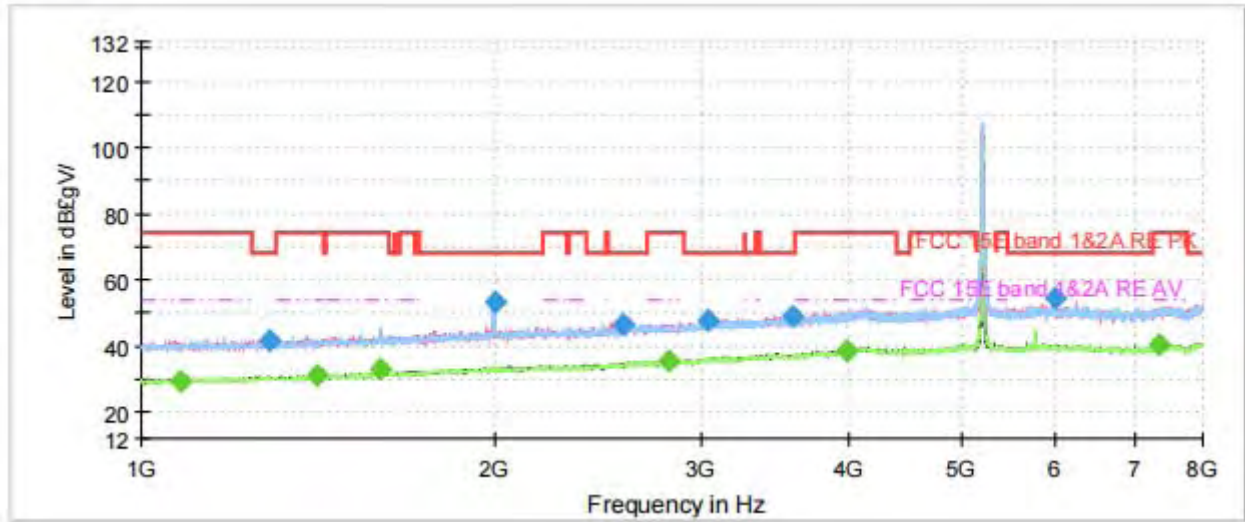

Note: The signal beyond the limit is carrier.
Radiates Emission from 1GHz to 8GHz

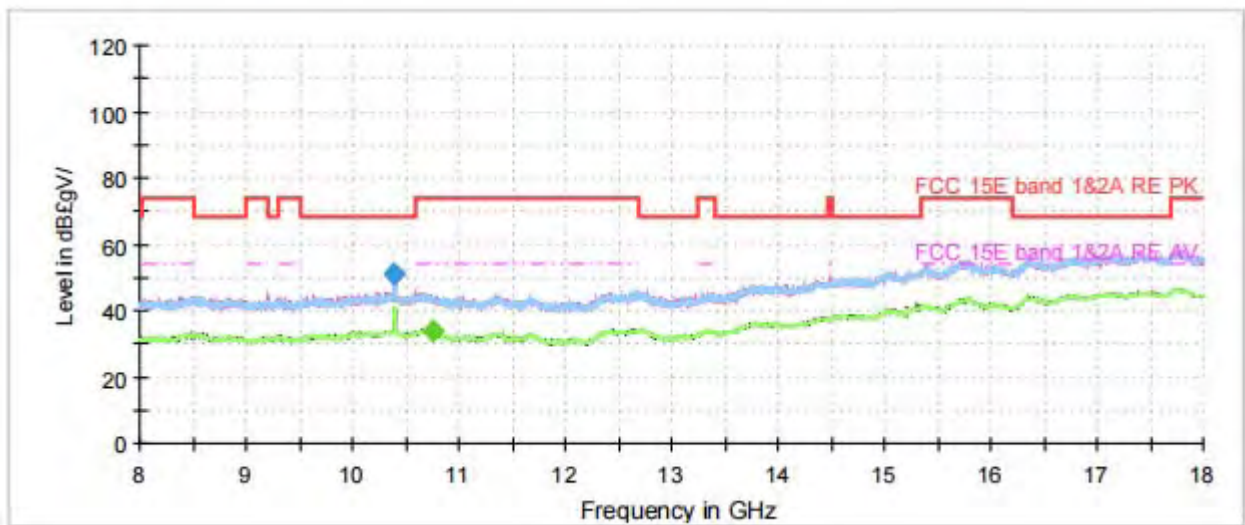

Radiates Emission from 8GHz to 18GHz



Frequency (MHz)	Peak (dBuV/m)	Average (dBuV/m)	Limit (dBuV/m)	Margin (dB)	Height (cm)	Polarization	Azimuth (deg)	Correct Factor (dB)
1079.625000	---	29.31	54.00	24.69	200.0	V	147.0	-7.9
1287.000000	41.67	---	68.20	26.53	200.0	H	221.0	-6.8
1413.875000	---	30.91	54.00	23.09	100.0	V	169.0	-6.1
1596.750000	---	32.84	54.00	21.16	200.0	V	285.0	-5.1
1999.250000	53.42	---	68.20	14.78	100.0	V	0.0	-2.7
2575.000000	46.73	---	68.20	21.47	200.0	V	141.0	-0.1
2814.750000	---	35.46	54.00	18.54	100.0	H	197.0	1.0
3032.625000	47.61	---	68.20	20.59	200.0	V	54.0	2.2
3583.875000	48.67	---	68.20	19.53	200.0	H	161.0	4.0
3975.875000	---	38.70	54.00	15.30	200.0	V	116.0	6.0
5990.125000	54.20	---	68.20	14.00	200.0	V	350.0	9.7
7357.750000	---	40.49	54.00	13.51	100.0	H	53.0	11.5

Remark: 1. Correction Factor = Antenna factor+ Insertion loss (cable loss + amplifier gain)

802.11a CH48

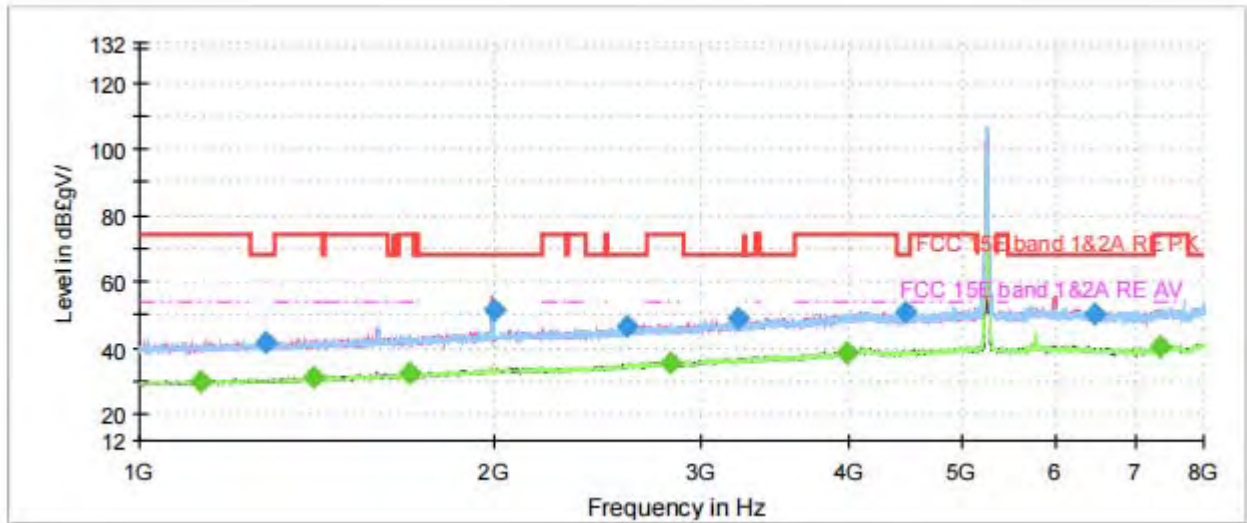

Note: The signal beyond the limit is carrier.
Radiates Emission from 1GHz to 8GHz

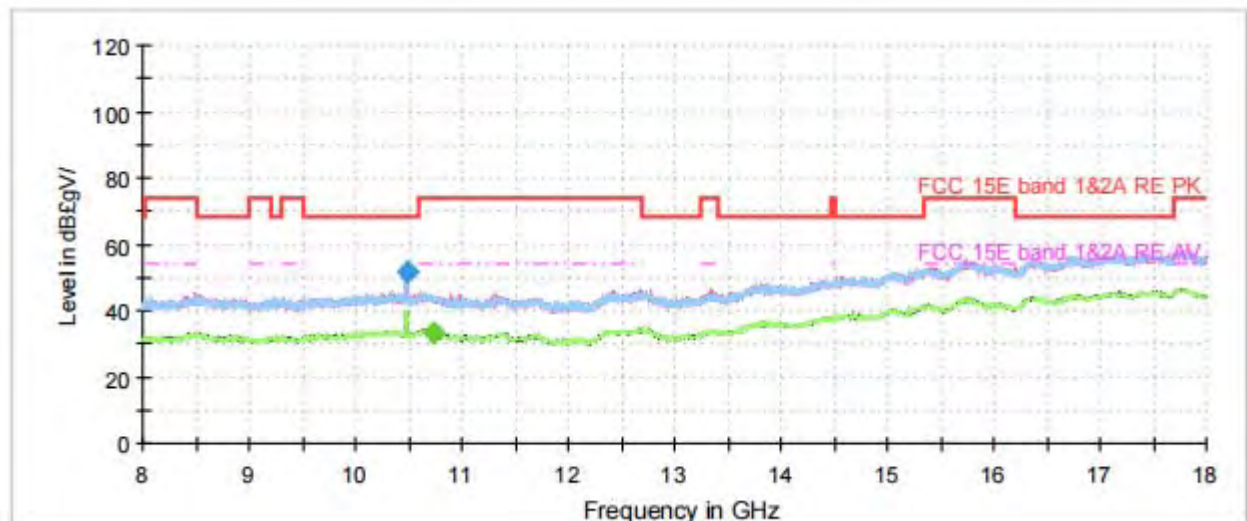

Radiates Emission from 8GHz to 18GHz



Frequency (MHz)	Peak (dBuV/m)	Average (dBuV/m)	Limit (dBuV/m)	Margin (dB)	Height (cm)	Polarization	Azimuth (deg)	Correct Factor (dB)
1124.250000	---	29.88	54.00	24.12	100.0	V	24.0	-7.7
1277.375000	41.46	---	68.20	26.74	200.0	H	353.0	-6.8
1402.500000	---	31.03	54.00	22.97	100.0	V	184.0	-6.1
1692.125000	---	32.12	54.00	21.88	100.0	V	238.0	-4.5
2000.125000	51.62	---	68.20	16.58	200.0	H	26.0	-2.7
2591.625000	46.46	---	68.20	21.74	100.0	V	322.0	0.0
2817.375000	---	35.44	54.00	18.56	100.0	V	316.0	1.0
3214.625000	49.09	---	68.20	19.11	200.0	H	353.0	2.7
3984.625000	---	38.71	54.00	15.29	100.0	V	353.0	6.1
4465.875000	50.64	---	68.20	17.56	200.0	V	156.0	6.4
6461.750000	50.44	---	68.20	17.76	200.0	V	199.0	10.3
7349.875000	---	40.57	54.00	13.43	200.0	H	223.0	11.5

Remark: 1. Correction Factor = Antenna factor+ Insertion loss (cable loss + amplifier gain)

802.11a CH52

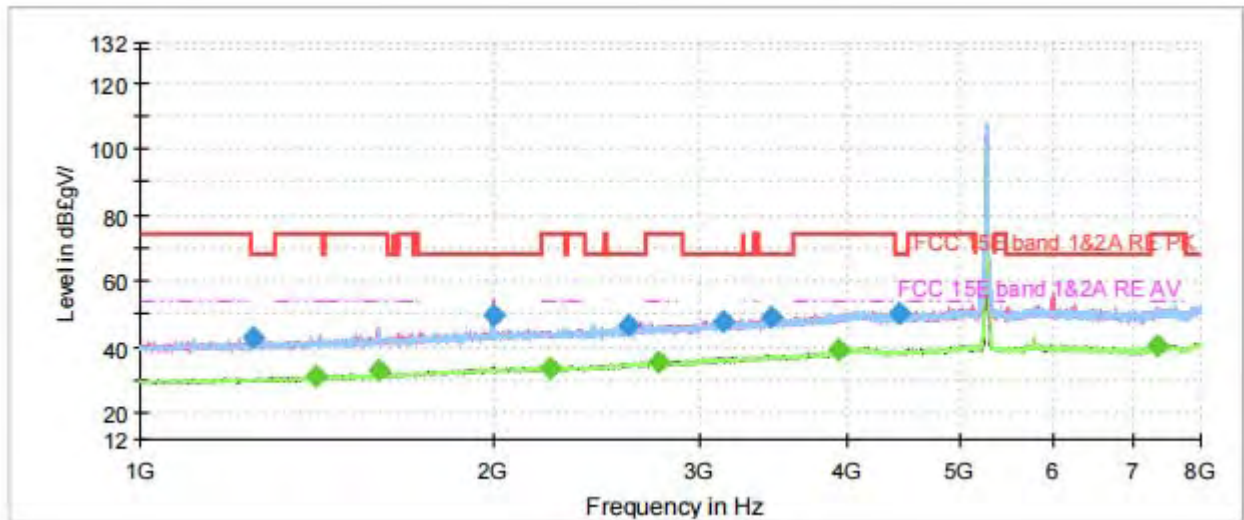

Note: The signal beyond the limit is carrier.
Radiates Emission from 1GHz to 8GHz

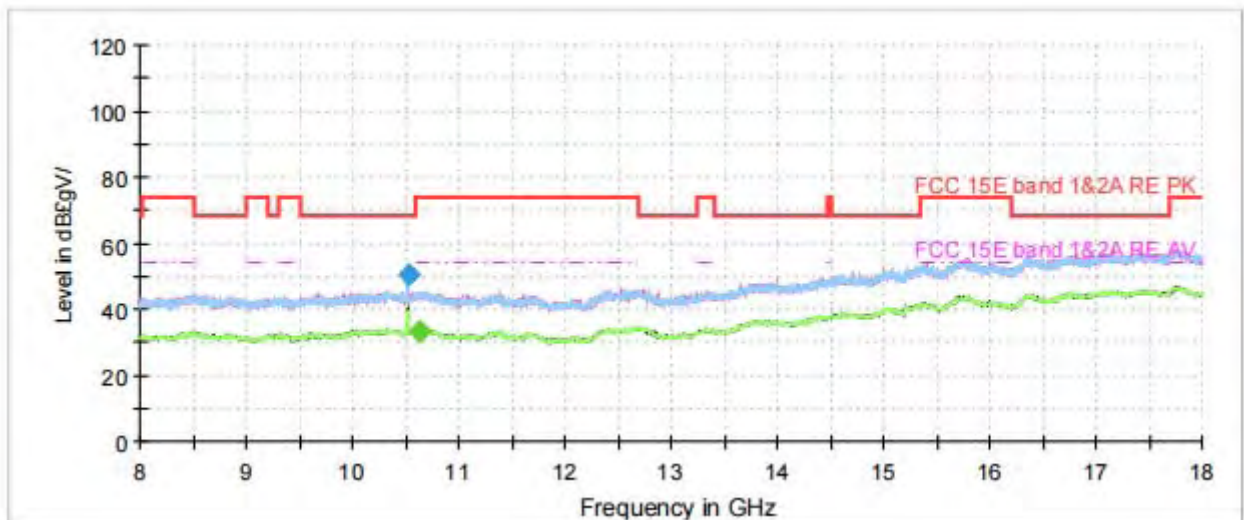

Radiates Emission from 8GHz to 18GHz



Frequency (MHz)	Peak (dBuV/m)	Average (dBuV/m)	Limit (dBuV/m)	Margin (dB)	Height (cm)	Polarization	Azimuth (deg)	Correct Factor (dB)
1249.375000	42.95	---	68.20	25.25	100.0	V	138.0	-7.0
1411.250000	---	31.06	54.00	22.94	200.0	V	17.0	-6.1
1595.000000	---	32.86	54.00	21.14	100.0	H	292.0	-5.1
2000.125000	49.70	---	68.20	18.50	200.0	V	238.0	-2.7
2235.500000	---	33.57	54.00	20.43	200.0	V	247.0	-1.7
2602.125000	46.34	---	68.20	21.86	100.0	H	16.0	0.0
2767.500000	---	35.49	54.00	18.51	100.0	H	57.0	0.8
3134.125000	47.66	---	68.20	20.54	100.0	H	0.0	2.5
3451.750000	49.07	---	68.20	19.13	200.0	V	295.0	3.6
3936.500000	---	38.92	54.00	15.08	200.0	V	183.0	5.7
4438.750000	50.17	---	68.20	18.03	200.0	H	197.0	6.3
7349.875000	---	40.26	54.00	13.74	100.0	H	10.0	11.5

Remark: 1. Correction Factor = Antenna factor+ Insertion loss (cable loss + amplifier gain)

802.11a CH60

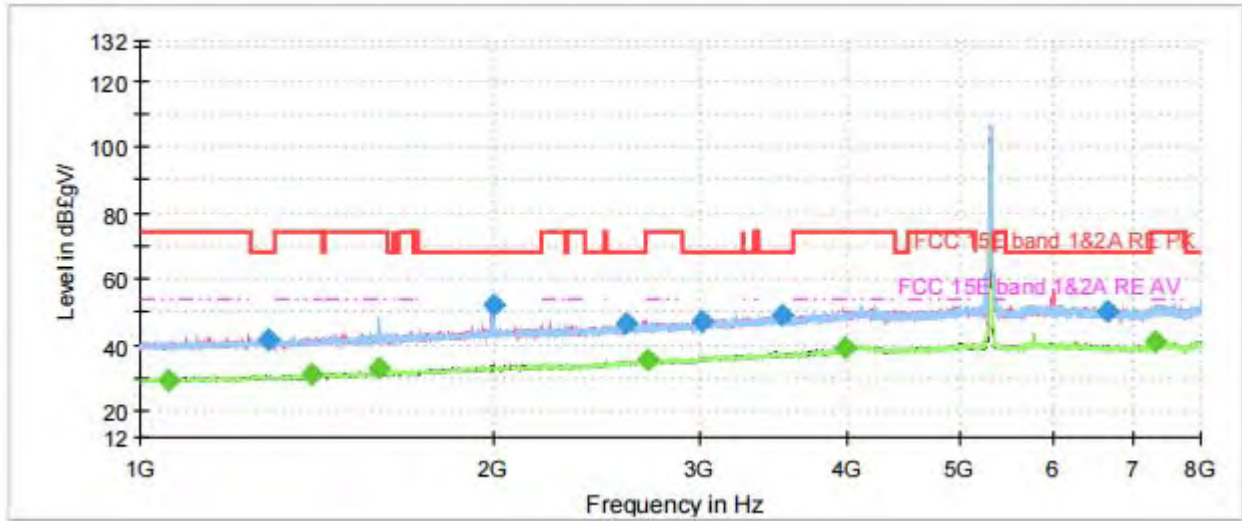

Note: The signal beyond the limit is carrier.
Radiates Emission from 1GHz to 8GHz

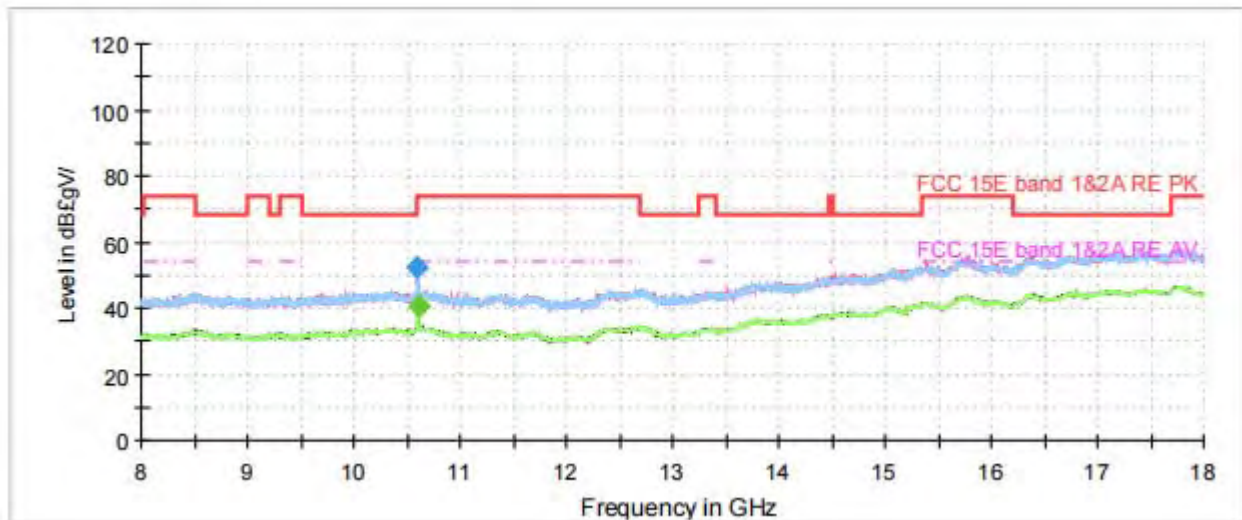

Radiates Emission from 8GHz to 18GHz



Frequency (MHz)	Peak (dBuV/m)	Average (dBuV/m)	Limit (dBuV/m)	Margin (dB)	Height (cm)	Polarization	Azimuth (deg)	Correct Factor (dB)
1055.125000	---	29.30	54.00	24.70	200.0	V	265.0	-8.1
1283.500000	41.79	---	68.20	26.41	200.0	V	134.0	-6.8
1398.125000	---	30.92	54.00	23.08	100.0	V	318.0	-6.2
1597.625000	---	33.17	54.00	20.83	200.0	H	356.0	-5.1
2000.125000	52.21	---	68.20	15.99	100.0	V	223.0	-2.7
2596.875000	46.19	---	68.20	22.01	200.0	H	214.0	0.0
2708.875000	---	35.41	54.00	18.59	100.0	H	104.0	0.6
3014.250000	46.87	---	68.20	21.33	200.0	V	277.0	2.0
3524.375000	48.90	---	68.20	19.30	100.0	V	343.0	3.8
3983.750000	---	38.89	54.00	15.11	200.0	H	208.0	6.1
6663.000000	50.42	---	68.20	17.78	200.0	V	73.0	10.4
7328.000000	---	40.63	54.00	13.37	100.0	V	0.0	11.4

Remark: 1. Correction Factor = Antenna factor+ Insertion loss (cable loss + amplifier gain)

802.11a CH64

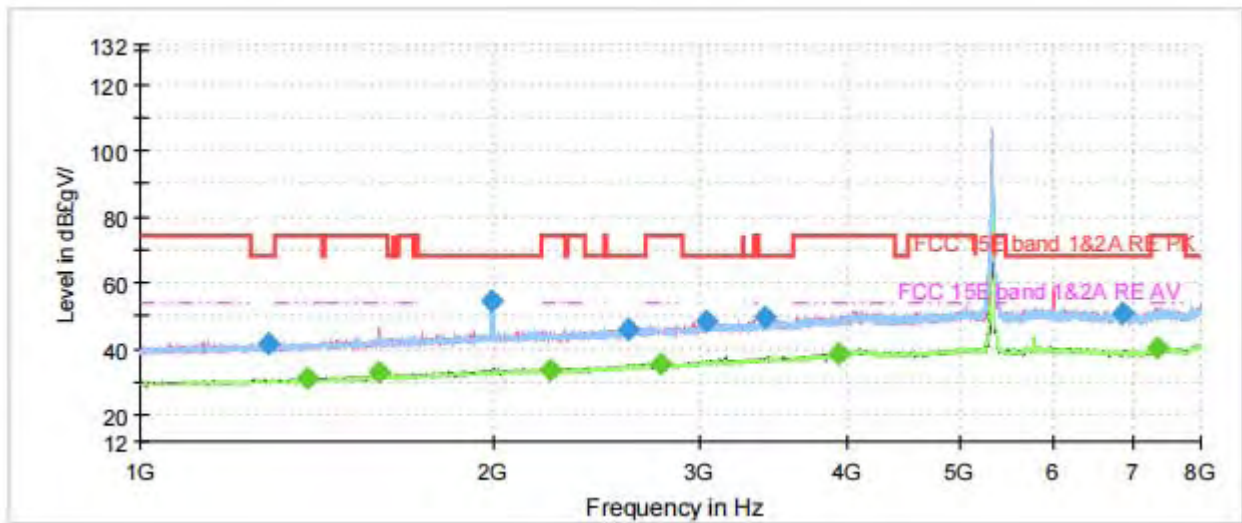

Note: The signal beyond the limit is carrier.
Radiates Emission from 1GHz to 8GHz

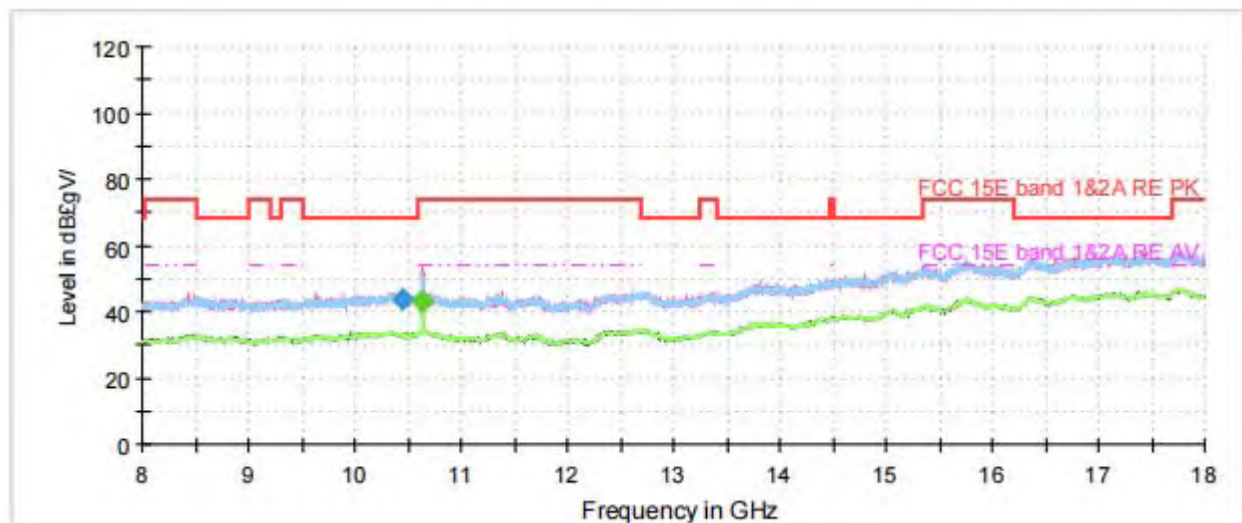

Radiates Emission from 8GHz to 18GHz



Frequency (MHz)	Peak (dBuV/m)	Average (dBuV/m)	Limit (dBuV/m)	Margin (dB)	Height (cm)	Polarization	Azimuth (deg)	Correct Factor (dB)
1284.375000	41.62	---	68.20	26.58	200.0	H	12.0	-6.8
1389.375000	---	30.97	54.00	23.03	100.0	V	149.0	-6.2
1598.500000	---	33.19	54.00	20.81	200.0	V	274.0	-5.1
1994.000000	54.19	---	68.20	14.01	200.0	V	304.0	-2.7
2234.625000	---	33.70	54.00	20.30	200.0	V	165.0	-1.7
2599.500000	45.70	---	68.20	22.50	200.0	V	142.0	0.0
2771.875000	---	35.38	54.00	18.62	100.0	H	201.0	0.8
3038.750000	48.14	---	68.20	20.06	200.0	V	125.0	2.2
3404.500000	49.24	---	68.20	18.96	200.0	V	119.0	3.4
3940.000000	---	38.72	54.00	15.28	100.0	H	10.0	5.7
6877.375000	50.60	---	68.20	17.60	100.0	V	240.0	10.7
7342.875000	---	40.39	54.00	13.61	200.0	H	309.0	11.4

Remark: 1. Correction Factor = Antenna factor+ Insertion loss (cable loss + amplifier gain)

802.11a CH100

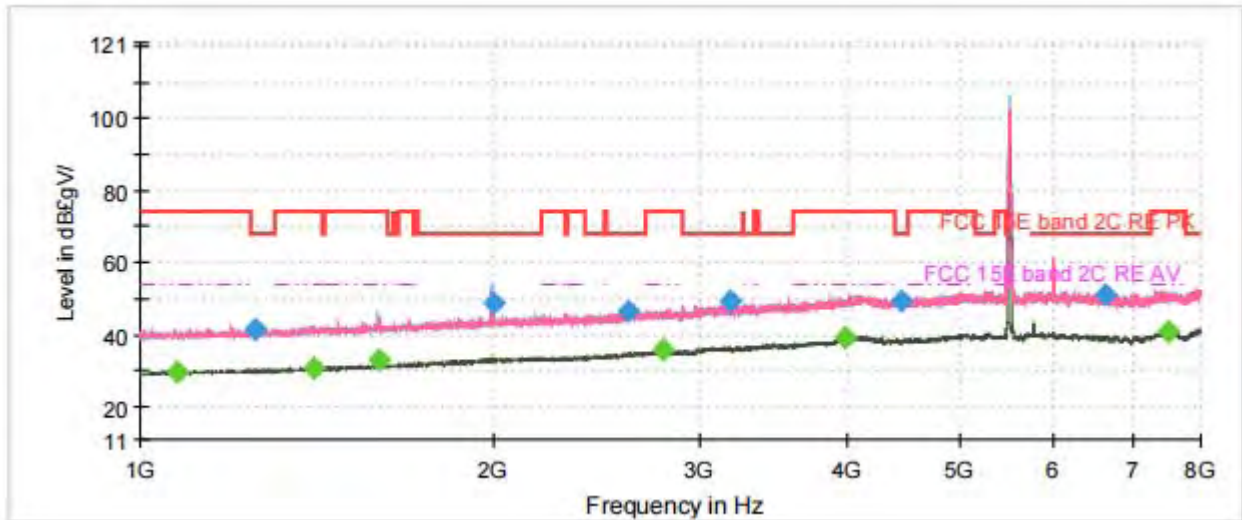

Note: The signal beyond the limit is carrier.
Radiates Emission from 1GHz to 8GHz

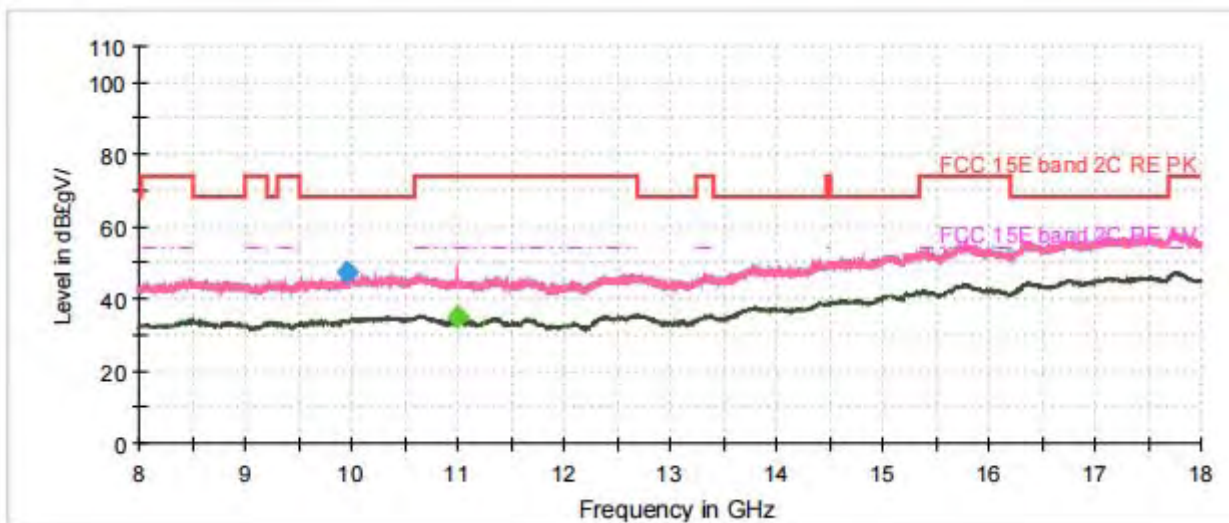

Radiates Emission from 8GHz to 18GHz



Frequency (MHz)	Peak (dBuV/m)	Average (dBuV/m)	Limit (dBuV/m)	Margin (dB)	Height (cm)	Polarization	Azimuth (deg)	Correct Factor (dB)
1077.000000	---	29.88	54.00	24.12	200.0	H	78.0	-7.9
1254.625000	41.63	---	68.20	26.57	200.0	H	114.0	-7.0
1406.000000	---	30.87	54.00	23.13	200.0	V	316.0	-6.1
1595.000000	---	32.75	54.00	21.25	200.0	H	322.0	-5.1
2000.125000	49.04	---	68.20	19.16	200.0	V	14.0	-2.7
2598.625000	46.78	---	68.20	21.42	200.0	V	271.0	0.0
2786.750000	---	35.56	54.00	18.44	200.0	H	114.0	0.9
3184.000000	49.14	---	68.20	19.06	200.0	H	0.0	2.6
3982.875000	---	38.98	54.00	15.02	100.0	V	18.0	6.0
4456.250000	49.52	---	68.20	18.68	200.0	H	114.0	6.4
6644.625000	51.03	---	68.20	17.17	200.0	H	6.0	10.4
7497.750000	---	40.65	54.00	13.35	100.0	V	50.0	11.5

Remark: 1. Correction Factor = Antenna factor+ Insertion loss (cable loss + amplifier gain)

802.11a CH116

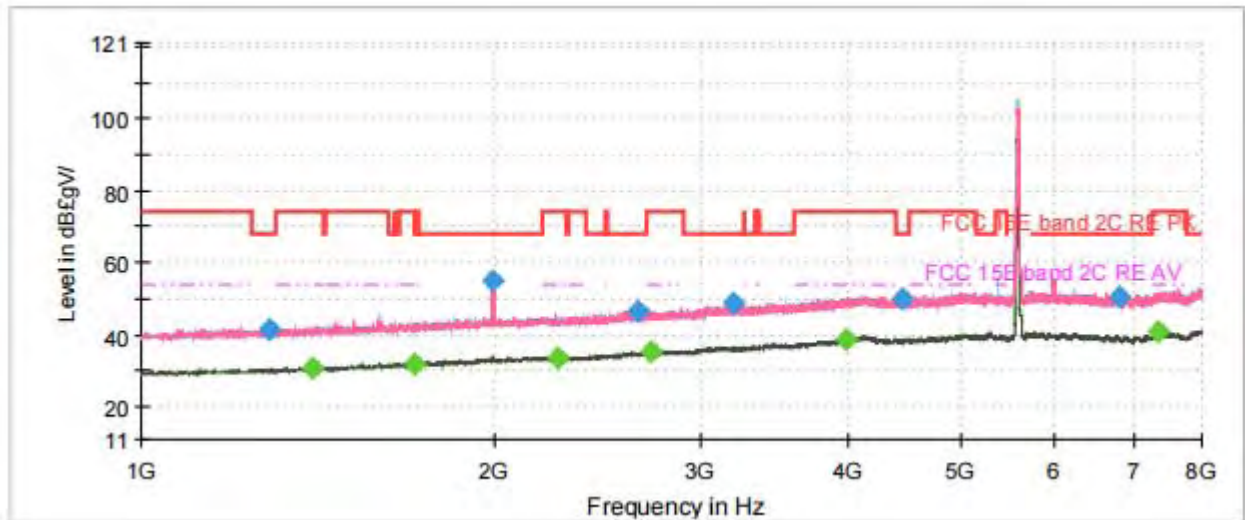

Note: The signal beyond the limit is carrier.
Radiates Emission from 1GHz to 8GHz

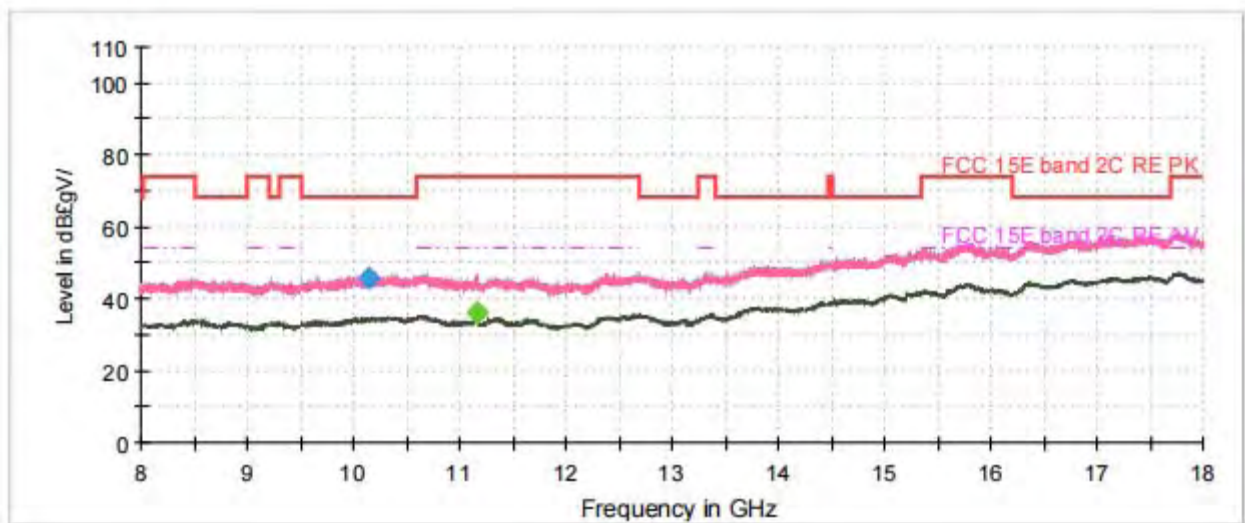

Radiates Emission from 8GHz to 18GHz



Frequency (MHz)	Peak (dBuV/m)	Average (dBuV/m)	Limit (dBuV/m)	Margin (dB)	Height (cm)	Polarization	Azimuth (deg)	Correct Factor (dB)
1287.000000	41.53	---	68.20	26.67	200.0	V	221.0	-6.8
1398.125000	---	30.99	54.00	23.01	200.0	H	14.0	-6.2
1705.250000	---	32.03	54.00	21.97	200.0	V	179.0	-4.5
1991.375000	54.86	---	68.20	13.34	200.0	V	293.0	-2.7
2260.000000	---	33.48	54.00	20.52	100.0	H	325.0	-1.6
2644.125000	46.74	---	68.20	21.46	200.0	H	184.0	0.3
2719.375000	---	35.44	54.00	18.56	100.0	H	62.0	0.6
3192.750000	48.85	---	68.20	19.35	200.0	V	269.0	2.6
3983.750000	---	38.68	54.00	15.32	100.0	H	0.0	6.1
4456.250000	50.11	---	68.20	18.09	100.0	H	50.0	6.4
6813.500000	50.59	---	68.20	17.61	200.0	V	324.0	10.6
7342.000000	---	40.82	54.00	13.18	200.0	H	102.0	11.4

Remark: 1. Correction Factor = Antenna factor+ Insertion loss (cable loss + amplifier gain)

802.11a CH140

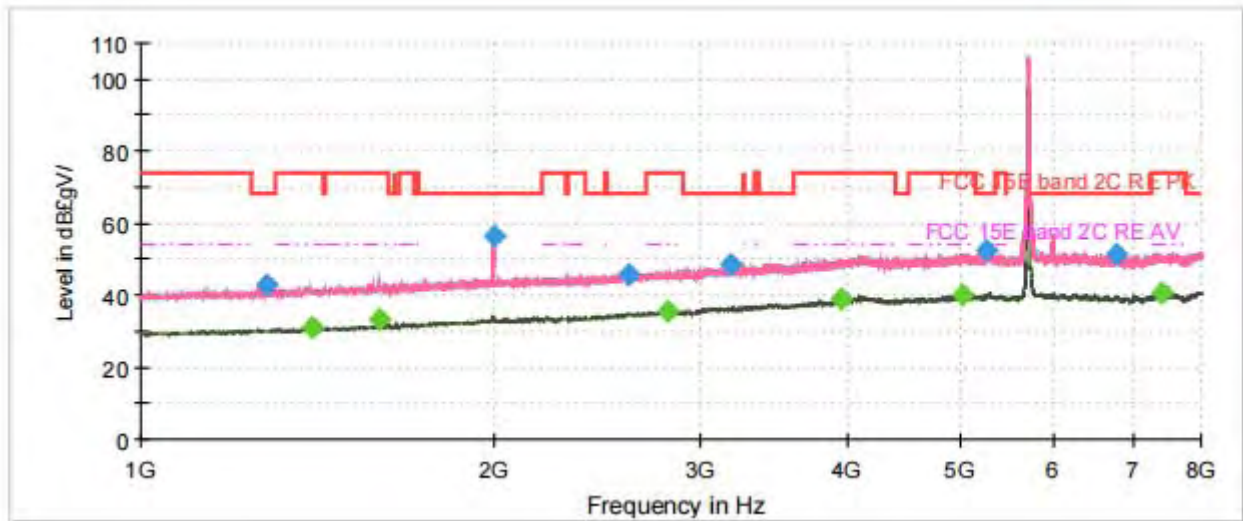

Note: The signal beyond the limit is carrier.
Radiates Emission from 1GHz to 8GHz

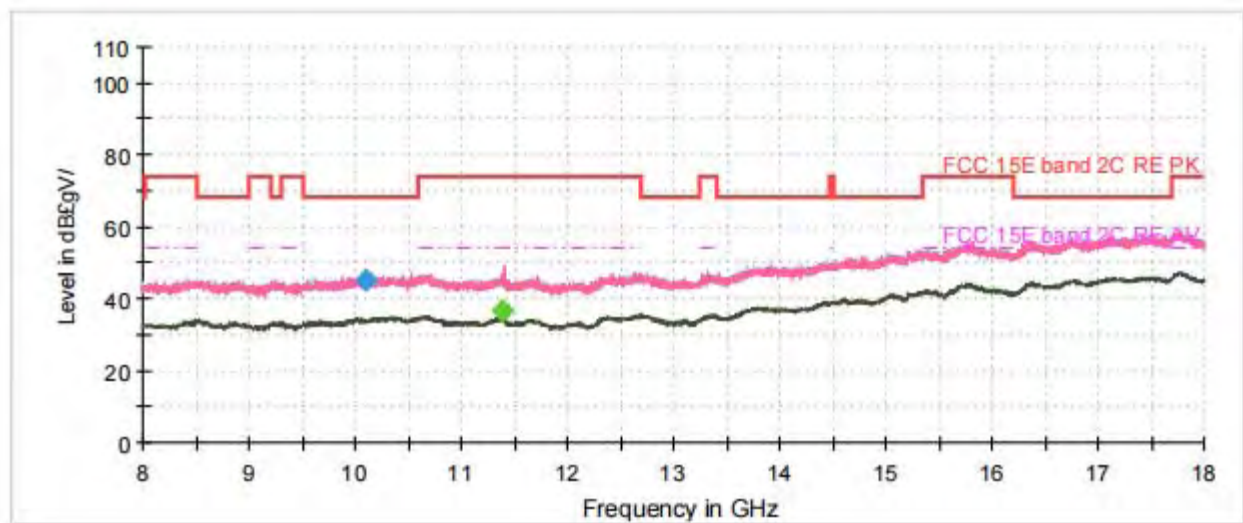

Radiates Emission from 8GHz to 18GHz



Frequency (MHz)	Peak (dBuV/m)	Average (dBuV/m)	Limit (dBuV/m)	Margin (dB)	Height (cm)	Polarization	Azimuth (deg)	Correct Factor (dB)
1280.875000	42.62	---	68.20	25.58	200.0	H	7.0	-6.8
1401.625000	---	30.86	54.00	23.14	200.0	H	98.0	-6.2
1594.125000	---	33.34	54.00	20.66	100.0	H	2.0	-5.1
1996.625000	56.59	---	68.20	11.61	100.0	V	0.0	-2.7
2603.000000	45.76	---	68.20	22.44	100.0	V	284.0	0.0
2811.250000	---	35.36	54.00	18.64	200.0	V	223.0	1.0
3183.125000	48.55	---	68.20	19.65	100.0	V	193.0	2.6
3946.125000	---	38.70	54.00	15.30	200.0	H	310.0	5.8
5018.875000	---	40.22	54.00	13.78	200.0	H	176.0	8.7
5257.750000	52.53	---	68.20	15.67	100.0	V	309.0	8.8
6784.625000	51.22	---	68.20	16.98	200.0	H	316.0	10.5
7403.250000	---	40.44	54.00	13.56	200.0	V	142.0	11.5

Remark: 1. Correction Factor = Antenna factor+ Insertion loss (cable loss + amplifier gain)

802.11a CH149

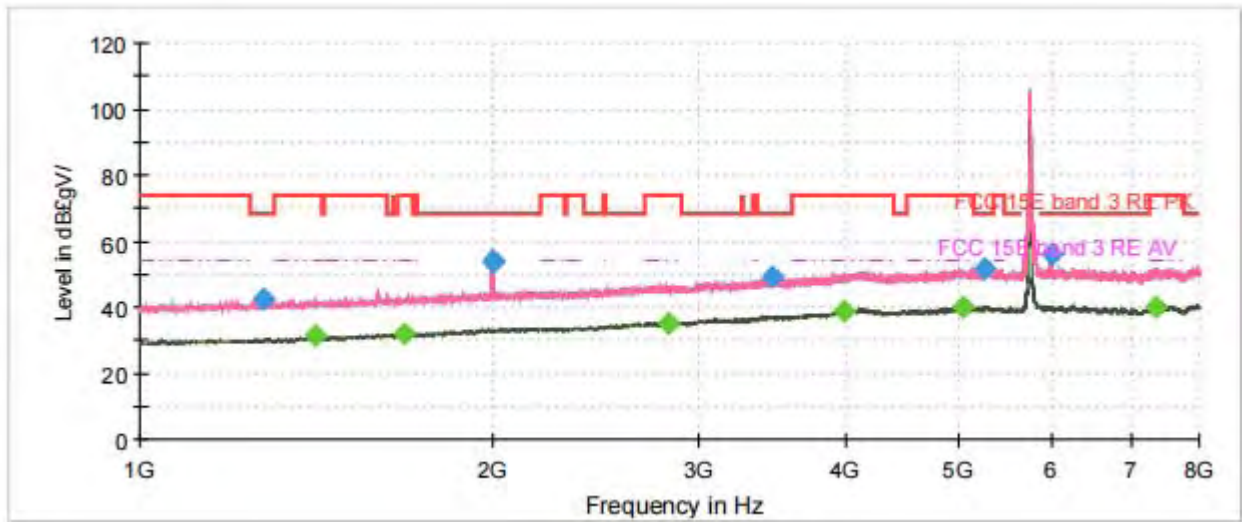

Note: The signal beyond the limit is carrier.
Radiates Emission from 1GHz to 8GHz

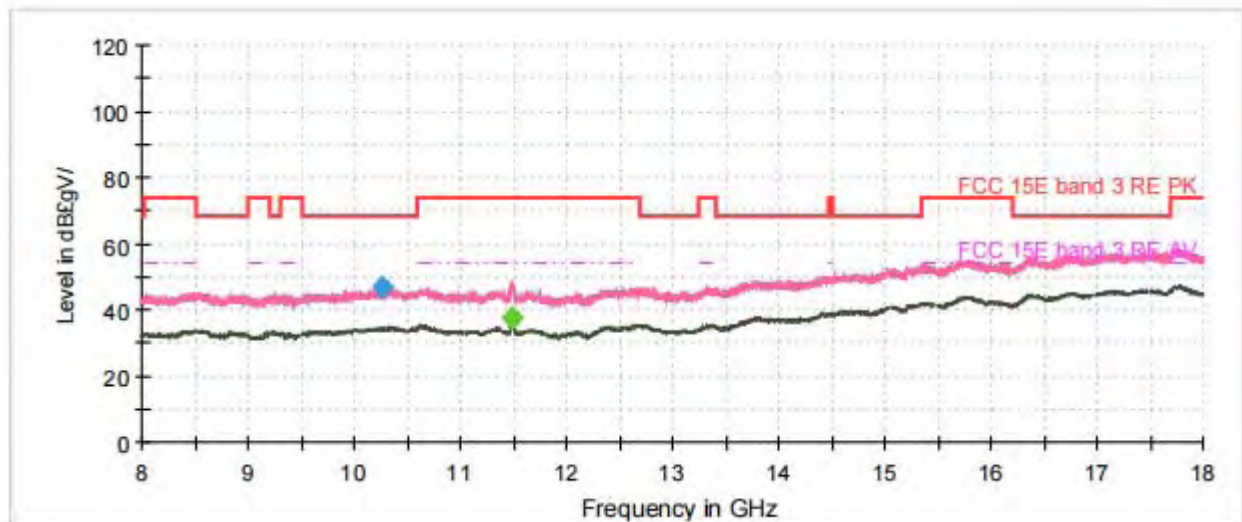

Radiates Emission from 8GHz to 18GHz



Frequency (MHz)	Peak (dBuV/m)	Average (dBuV/m)	Limit (dBuV/m)	Margin (dB)	Height (cm)	Polarization	Azimuth (deg)	Correct Factor (dB)
1275.625000	42.20	---	68.20	26.00	100.0	V	0.0	-6.9
1413.875000	---	31.19	54.00	22.81	200.0	V	28.0	-6.1
1680.750000	---	31.92	54.00	22.08	100.0	V	279.0	-4.6
1997.500000	53.92	---	68.20	14.28	200.0	H	2.0	-2.7
2000.125000	53.79	---	68.20	14.41	200.0	V	346.0	-2.7
2822.625000	---	35.34	54.00	18.66	200.0	H	154.0	1.0
3456.125000	49.39	---	68.20	18.81	100.0	H	124.0	3.6
3980.250000	---	38.85	54.00	15.15	200.0	V	108.0	6.0
5039.875000	---	40.14	54.00	13.86	200.0	V	0.0	8.7
5258.625000	51.95	---	68.20	16.25	200.0	H	289.0	8.8
5990.125000	56.22	---	68.20	11.99	200.0	V	359.0	9.7
7356.000000	---	40.25	54.00	13.75	100.0	H	124.0	11.5

Remark: 1. Correction Factor = Antenna factor+ Insertion loss (cable loss + amplifier gain)

802.11a CH157

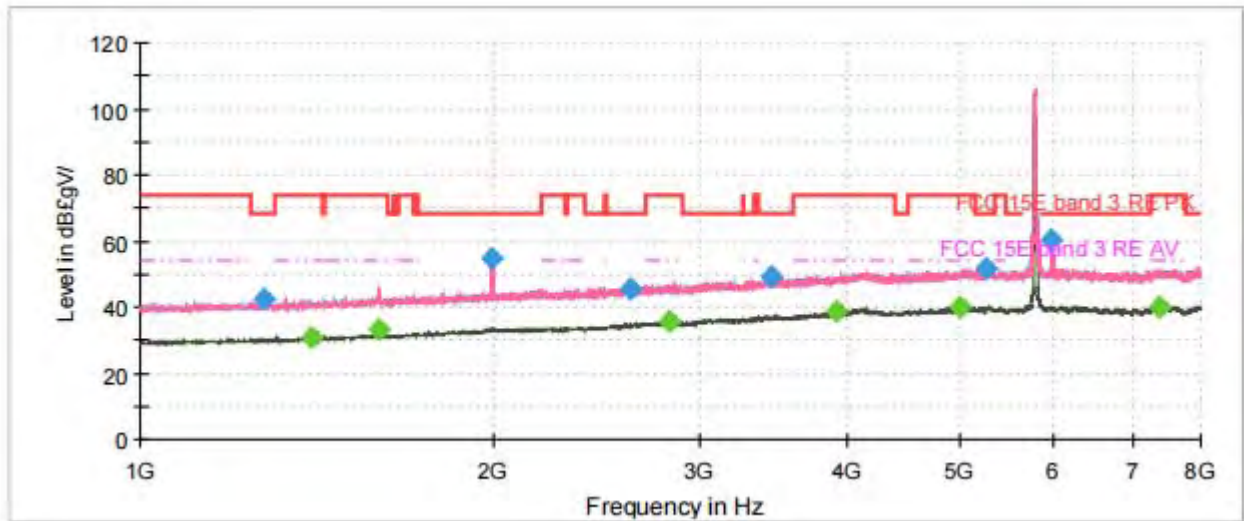

Note: The signal beyond the limit is carrier.
Radiates Emission from 1GHz to 8GHz

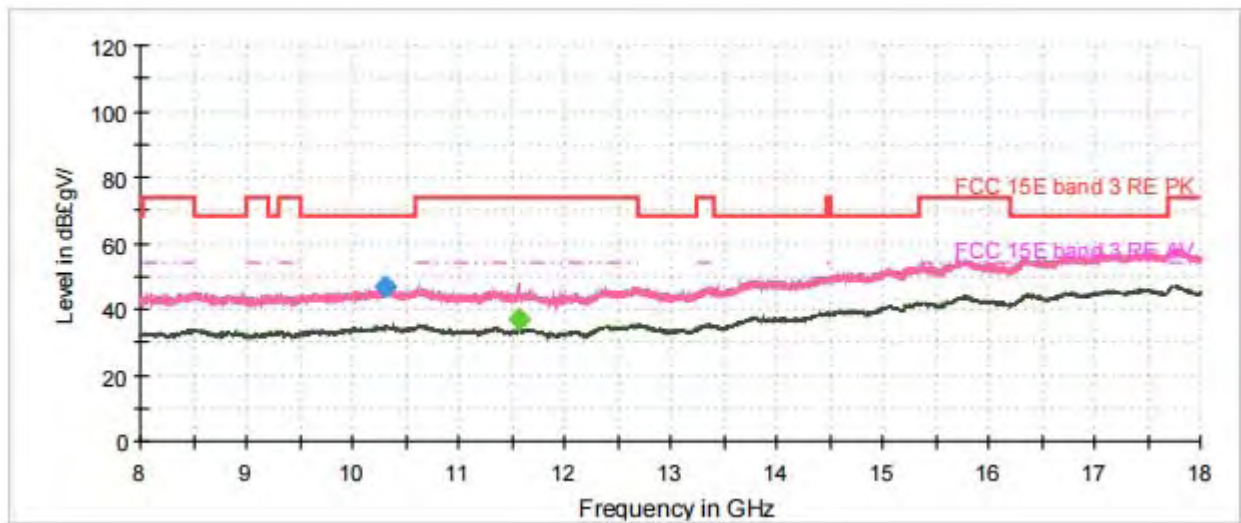

Radiates Emission from 8GHz to 18GHz



Frequency (MHz)	Peak (dBuV/m)	Average (dBuV/m)	Limit (dBuV/m)	Margin (dB)	Height (cm)	Polarization	Azimuth (deg)	Correct Factor (dB)
1273.875000	42.72	---	68.20	25.48	100.0	V	117.0	-6.9
1400.750000	---	30.93	54.00	23.07	100.0	H	228.0	-6.2
1597.625000	---	33.03	54.00	20.97	200.0	V	284.0	-5.1
1995.750000	54.62	---	68.20	13.58	200.0	H	19.0	-2.7
2617.000000	45.80	---	68.20	22.40	200.0	H	316.0	0.1
2827.000000	---	35.39	54.00	18.61	200.0	V	64.0	1.0
3446.500000	48.94	---	68.20	19.26	200.0	V	133.0	3.6
3923.375000	---	38.95	54.00	15.05	100.0	H	192.0	5.6
5000.500000	---	40.09	54.00	13.91	200.0	V	139.0	8.7
5253.375000	51.76	---	68.20	16.44	100.0	H	174.0	8.8
5976.125000	60.61	---	68.20	7.59	100.0	V	340.0	9.7
7381.375000	---	40.18	54.00	13.82	100.0	V	201.0	11.5

Remark: 1. Correction Factor = Antenna factor+ Insertion loss (cable loss + amplifier gain)



802.11a CH165

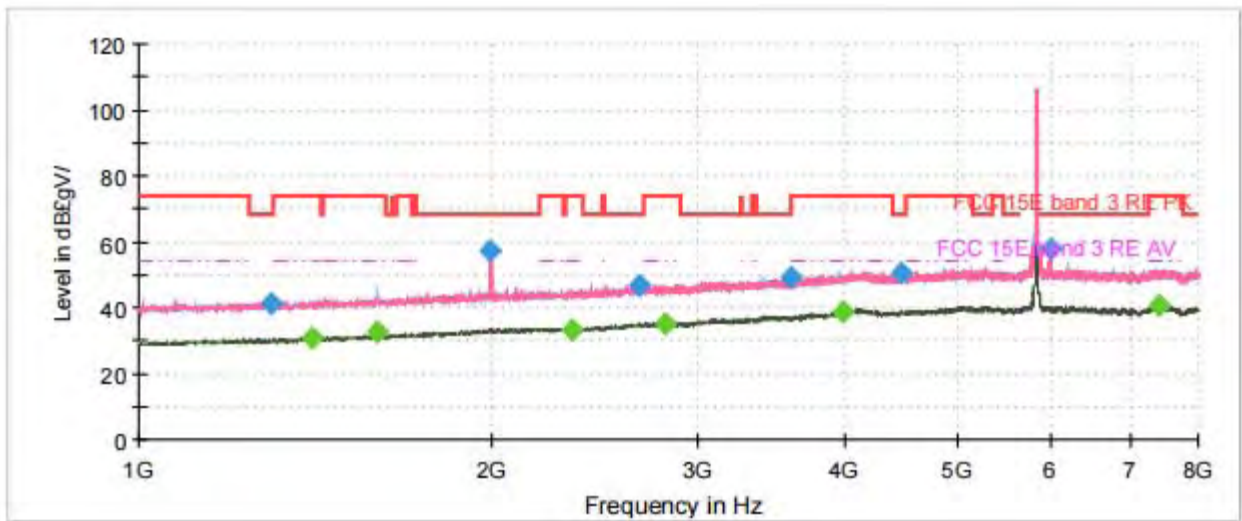

Note: The signal beyond the limit is carrier.
Radiates Emission from 1GHz to 8GHz

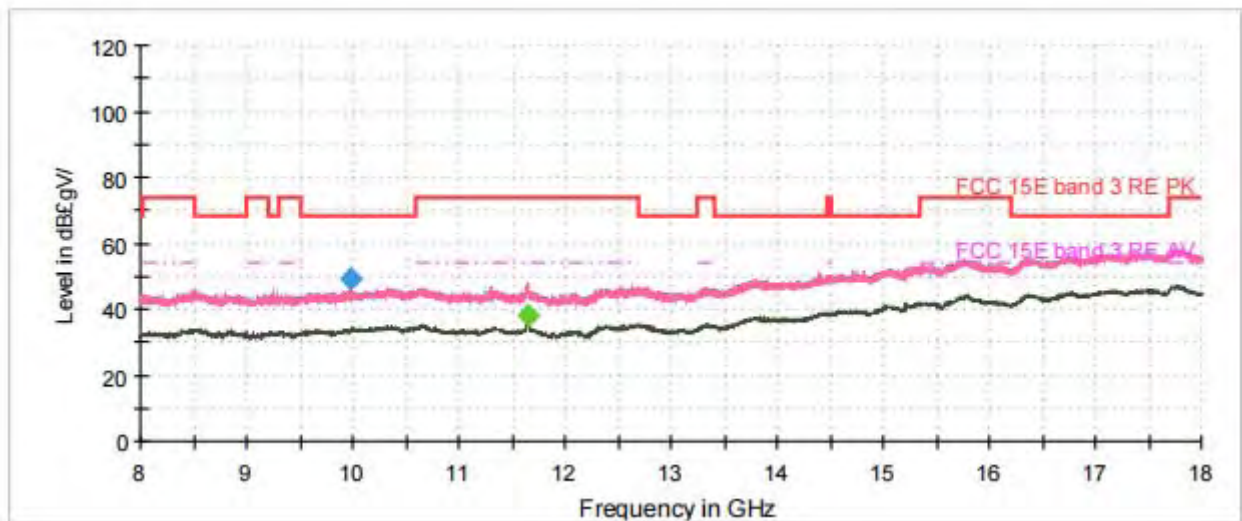

Radiates Emission from 8GHz to 18GHz



Frequency (MHz)	Peak (dBuV/m)	Average (dBuV/m)	Limit (dBuV/m)	Margin (dB)	Height (cm)	Polarization	Azimuth (deg)	Correct Factor (dB)
1297.500000	41.53	---	68.20	26.67	200.0	V	88.0	-6.8
1403.375000	---	30.91	54.00	23.09	100.0	V	0.0	-6.1
1599.375000	---	32.73	54.00	21.27	200.0	H	319.0	-5.0
1994.000000	57.05	---	68.20	11.15	200.0	V	106.0	-2.7
2339.000000	---	33.50	54.00	20.50	200.0	H	319.0	-1.5
2665.125000	46.71	---	68.20	21.49	100.0	H	79.0	0.4
2814.750000	---	35.33	54.00	18.67	200.0	V	238.0	1.0
3591.750000	49.22	---	68.20	18.98	200.0	V	69.0	4.0
3975.000000	---	38.56	54.00	15.44	100.0	V	178.0	6.0
4465.875000	50.21	---	68.20	17.99	100.0	H	200.0	6.4
5995.375000	57.75	---	68.20	10.45	100.0	V	295.0	9.7
7399.750000	---	40.41	54.00	13.59	200.0	H	291.0	11.5

Remark: 1. Correction Factor = Antenna factor+ Insertion loss (cable loss + amplifier gain)

802.11n (HT20) CH36

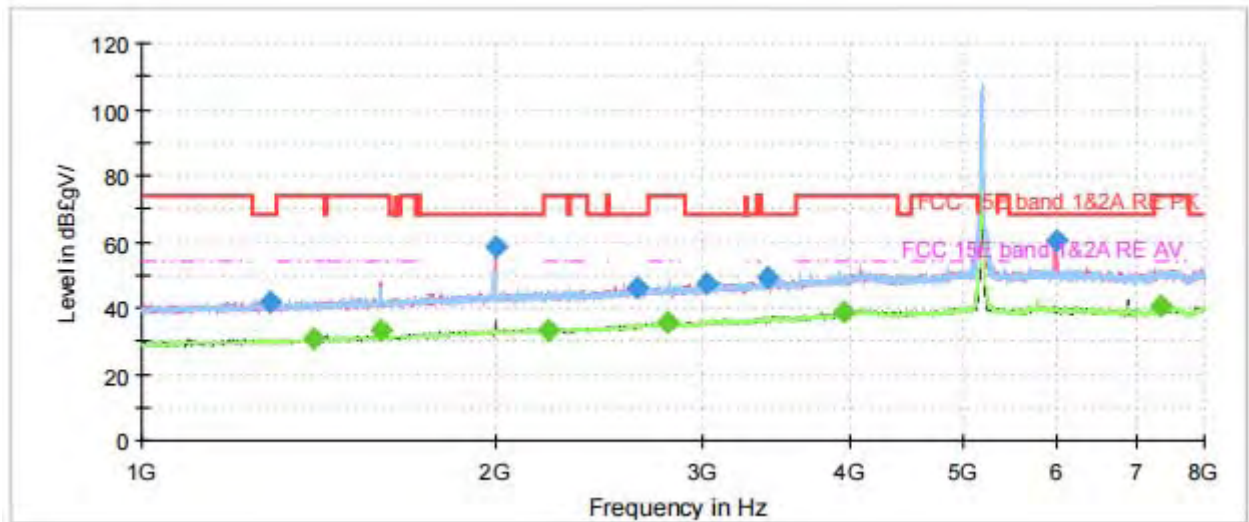

Note: The signal beyond the limit is carrier.
Radiates Emission from 1GHz to 8GHz

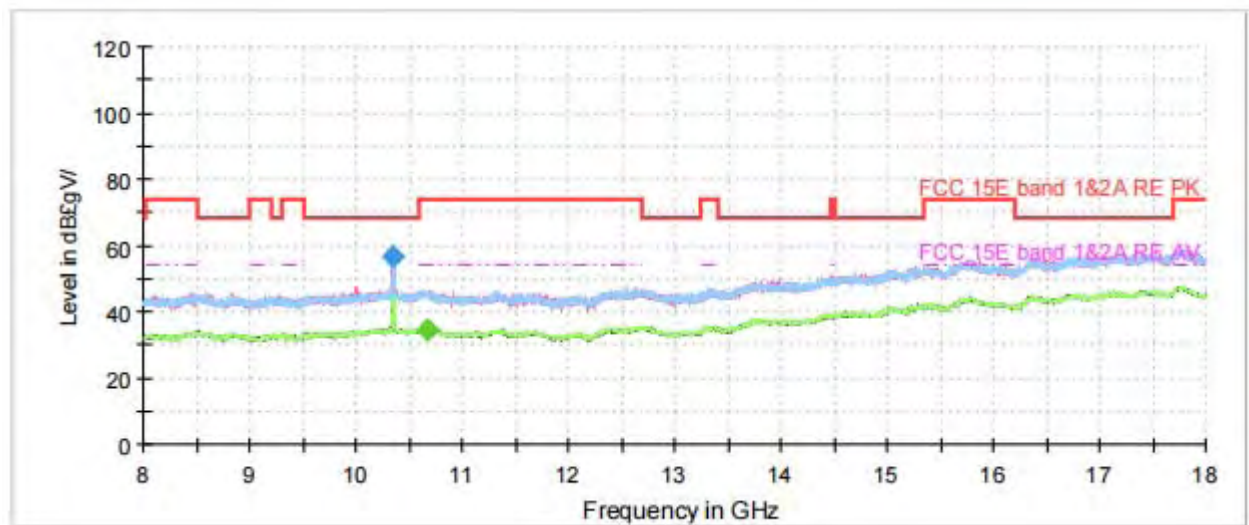

Radiates Emission from 8GHz to 18GHz



Frequency (MHz)	Peak (dBuV/m)	Average (dBuV/m)	Limit (dBuV/m)	Margin (dB)	Height (cm)	Polarization	Azimuth (deg)	Correct Factor (dB)
1284.375000	42.08	---	68.20	26.12	100.0	H	311.0	-6.8
1399.875000	---	30.76	54.00	23.24	200.0	V	353.0	-6.2
1595.875000	---	32.94	54.00	21.06	200.0	V	281.0	-5.1
1996.625000	58.62	---	68.20	9.58	100.0	V	294.0	-2.7
2212.750000	---	33.50	54.00	20.50	200.0	H	39.0	-1.7
2636.250000	46.19	---	68.20	22.01	200.0	V	61.0	0.3
2794.625000	---	35.49	54.00	18.51	100.0	V	18.0	0.9
3021.250000	47.62	---	68.20	20.58	200.0	H	244.0	2.1
3409.750000	49.25	---	68.20	18.95	200.0	V	258.0	3.5
3954.000000	---	38.64	54.00	15.36	100.0	H	340.0	5.8
5989.250000	60.12	---	68.20	8.08	100.0	V	189.0	9.7
7356.000000	---	40.61	54.00	13.39	100.0	H	264.0	11.5

Remark: 1. Correction Factor = Antenna factor+ Insertion loss (cable loss + amplifier gain)

802.11n (HT20) CH40

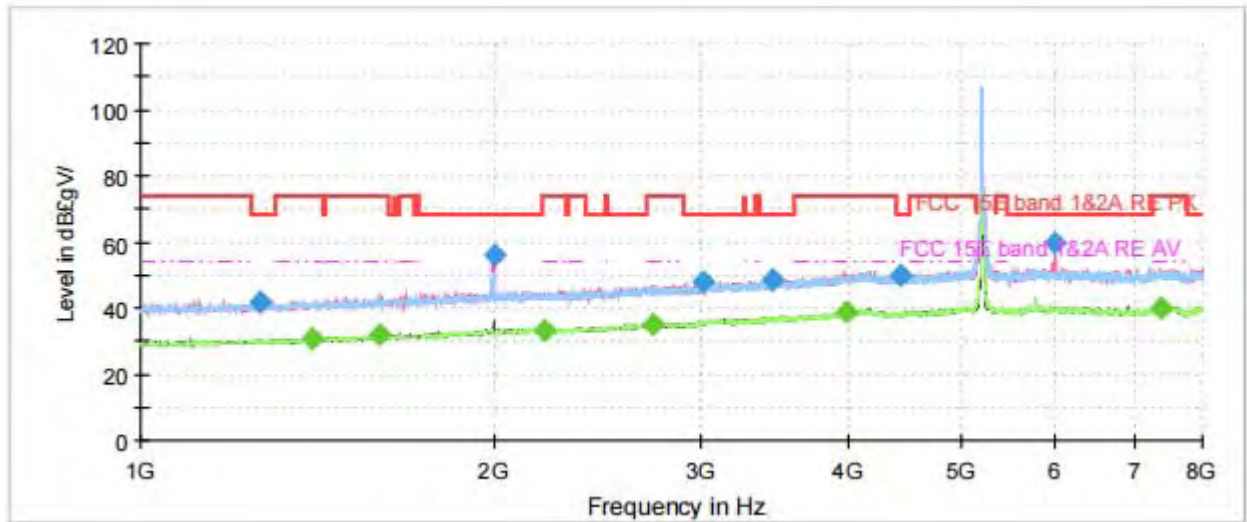

Note: The signal beyond the limit is carrier.
Radiates Emission from 1GHz to 8GHz

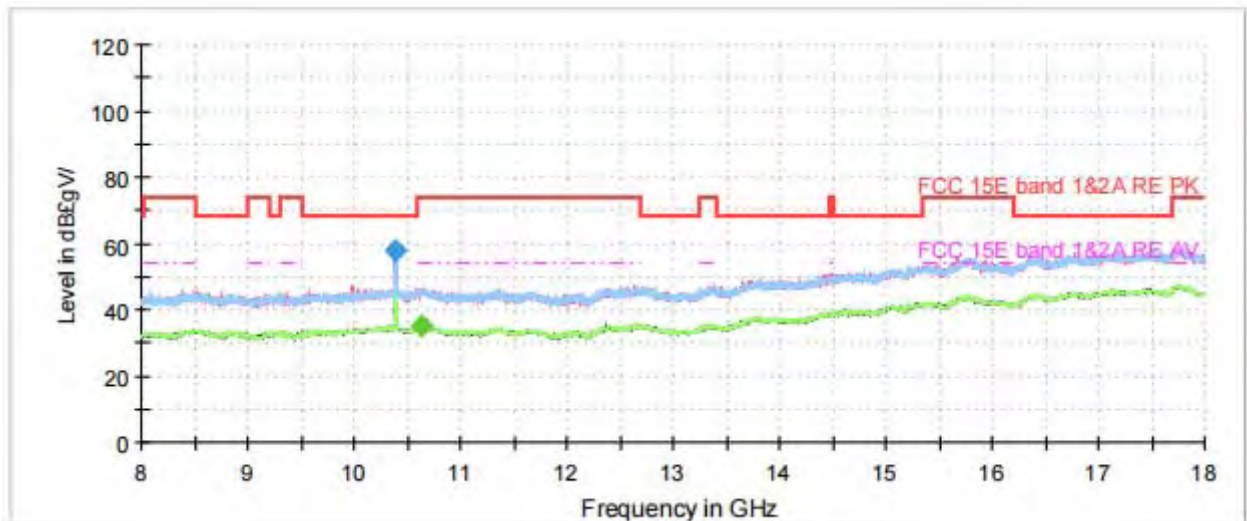

Radiates Emission from 8GHz to 18GHz



Frequency (MHz)	Peak (dBuV/m)	Average (dBuV/m)	Limit (dBuV/m)	Margin (dB)	Height (cm)	Polarization	Azimuth (deg)	Correct Factor (dB)
1261.625000	42.14	---	68.20	26.06	200.0	H	212.0	-6.9
1400.750000	---	30.71	54.00	23.29	100.0	V	66.0	-6.2
1594.125000	---	32.12	54.00	21.88	200.0	V	275.0	-5.1
1996.625000	56.19	---	68.20	12.01	100.0	V	353.0	-2.7
2206.625000	---	33.50	54.00	20.50	100.0	V	206.0	-1.8
2730.750000	---	35.25	54.00	18.75	200.0	H	137.0	0.7
3013.375000	47.97	---	68.20	20.23	100.0	V	254.0	2.0
3450.000000	48.86	---	68.20	19.34	100.0	H	103.0	3.6
3978.500000	---	38.77	54.00	15.23	200.0	V	191.0	6.0
4425.625000	49.82	---	68.20	18.38	200.0	H	92.0	6.3
5982.250000	59.41	---	68.20	8.79	100.0	V	102.0	9.7
7387.500000	---	40.25	54.00	13.75	100.0	H	321.0	11.5

Remark: 1. Correction Factor = Antenna factor+ Insertion loss (cable loss + amplifier gain)

802.11n (HT20) CH48

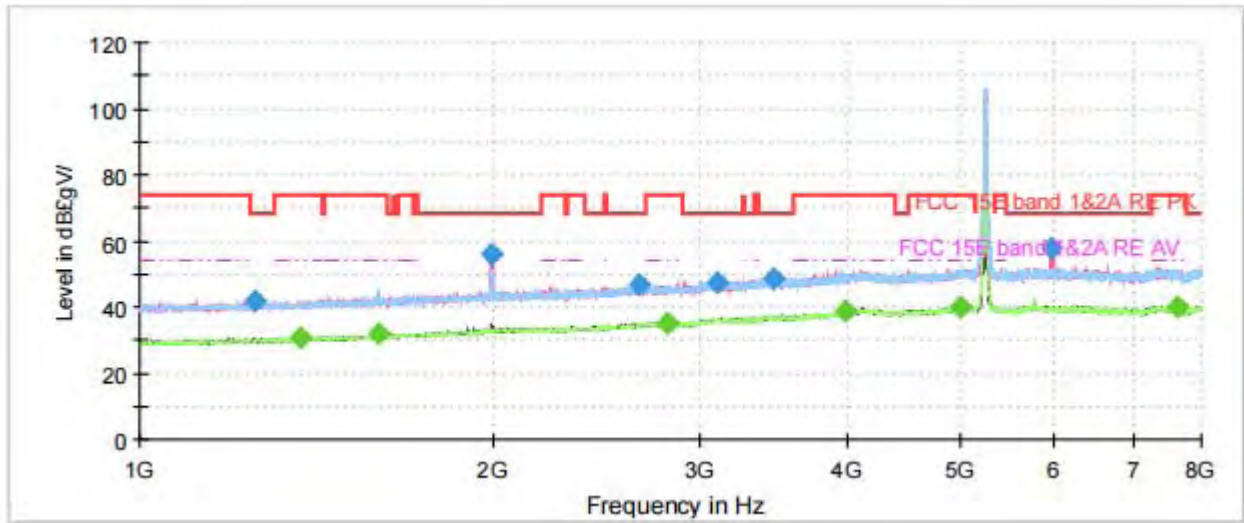

Note: The signal beyond the limit is carrier.
Radiates Emission from 1GHz to 8GHz

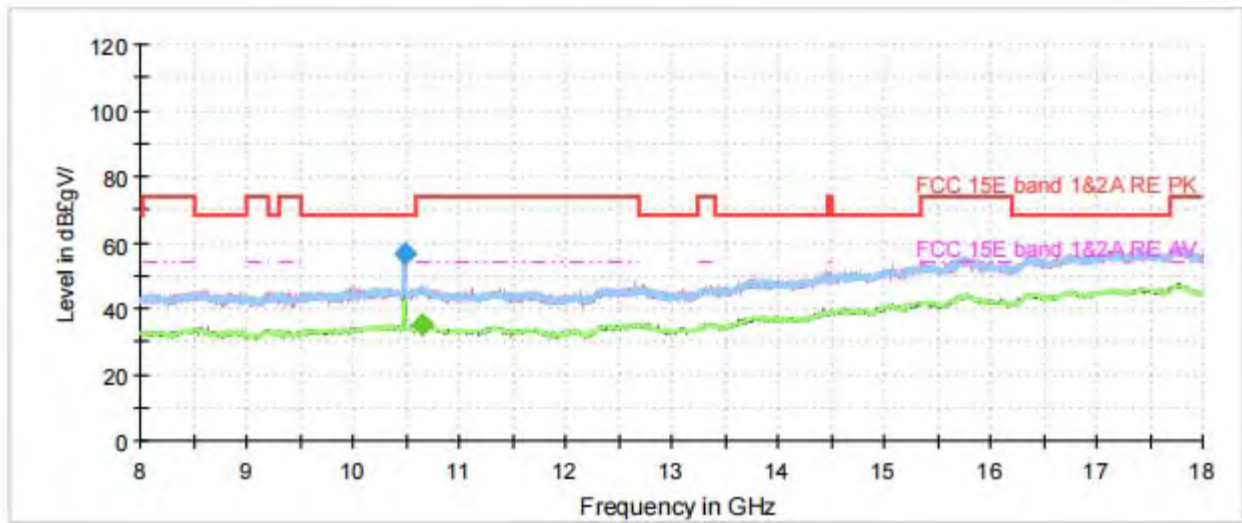

Radiates Emission from 8GHz to 18GHz



Frequency (MHz)	Peak (dBuV/m)	Average (dBuV/m)	Limit (dBuV/m)	Margin (dB)	Height (cm)	Polarization	Azimuth (deg)	Correct Factor (dB)
1252.000000	41.80	---	68.20	26.40	200.0	H	14.0	-7.0
1367.500000	---	30.69	54.00	23.31	200.0	V	357.0	-6.4
1595.000000	---	32.00	54.00	22.00	200.0	V	278.0	-5.1
1994.875000	56.18	---	68.20	12.02	100.0	V	350.0	-2.7
2657.250000	46.53	---	68.20	21.67	200.0	H	80.0	0.4
2811.250000	---	35.22	54.00	18.78	100.0	H	348.0	1.0
3100.875000	47.08	---	68.20	21.12	100.0	V	226.0	2.5
3465.750000	48.76	---	68.20	19.44	100.0	V	226.0	3.6
3989.875000	---	38.61	54.00	15.39	200.0	V	198.0	6.1
4999.625000	---	40.15	54.00	13.85	100.0	V	118.0	8.7
5977.875000	57.84	---	68.20	10.36	200.0	V	278.0	9.7
7618.500000	---	40.25	54.00	13.75	200.0	V	357.0	11.4

Remark: 1. Correction Factor = Antenna factor+ Insertion loss (cable loss + amplifier gain)

802.11n (HT20) CH52

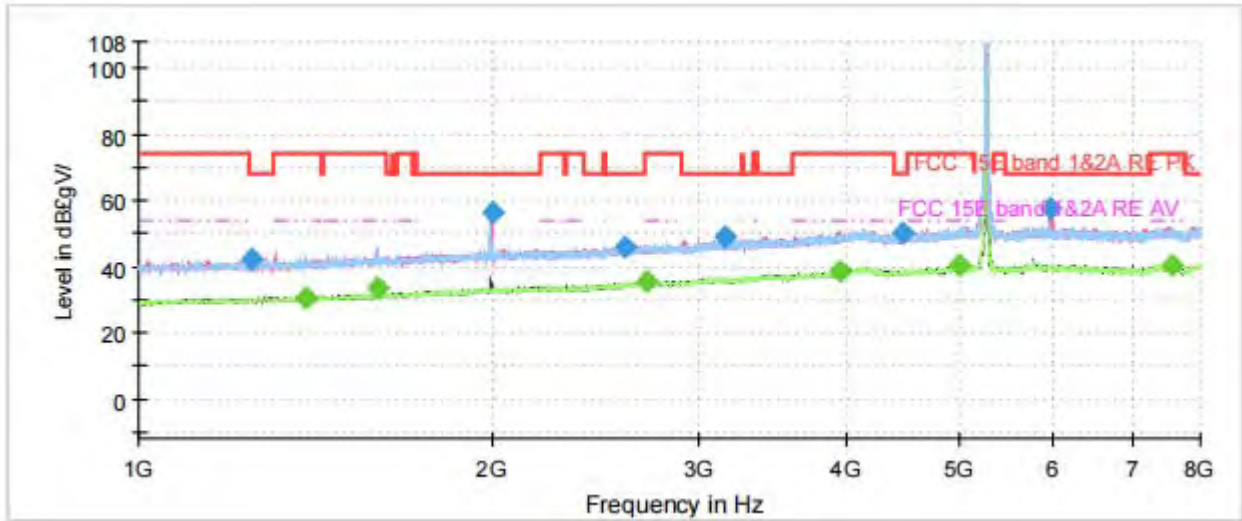

Note: The signal beyond the limit is carrier.
Radiates Emission from 1GHz to 8GHz

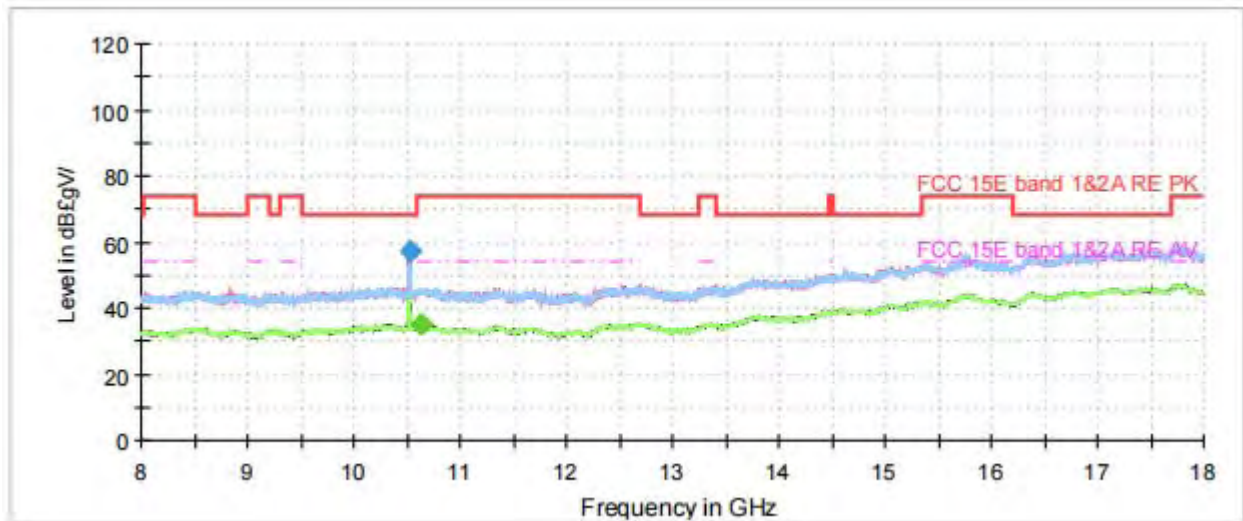

Radiates Emission from 8GHz to 18GHz



Frequency (MHz)	Peak (dBuV/m)	Average (dBuV/m)	Limit (dBuV/m)	Margin (dB)	Height (cm)	Polarization	Azimuth (deg)	Correct Factor (dB)
1245.000000	41.93	---	68.20	26.27	100.0	V	162.0	-7.0
1390.250000	---	30.67	54.00	23.33	100.0	H	0.0	-6.2
1597.625000	---	33.56	54.00	20.44	100.0	H	312.0	-5.1
1996.625000	56.52	---	68.20	11.68	200.0	V	233.0	-2.7
2590.750000	45.67	---	68.20	22.53	200.0	V	215.0	0.0
2708.875000	---	35.43	54.00	18.57	200.0	H	26.0	0.6
3151.625000	49.18	---	68.20	19.02	200.0	H	2.0	2.5
3954.875000	---	38.67	54.00	15.33	200.0	V	227.0	5.8
4468.500000	50.08	---	68.20	18.12	200.0	V	257.0	6.4
4999.625000	---	40.16	54.00	13.84	200.0	H	74.0	8.7
5974.375000	57.49	---	68.20	10.71	100.0	V	86.0	9.7
7584.375000	---	40.29	54.00	13.71	100.0	V	0.0	11.4

Remark: 1. Correction Factor = Antenna factor+ Insertion loss (cable loss + amplifier gain)

802.11n (HT20) CH60

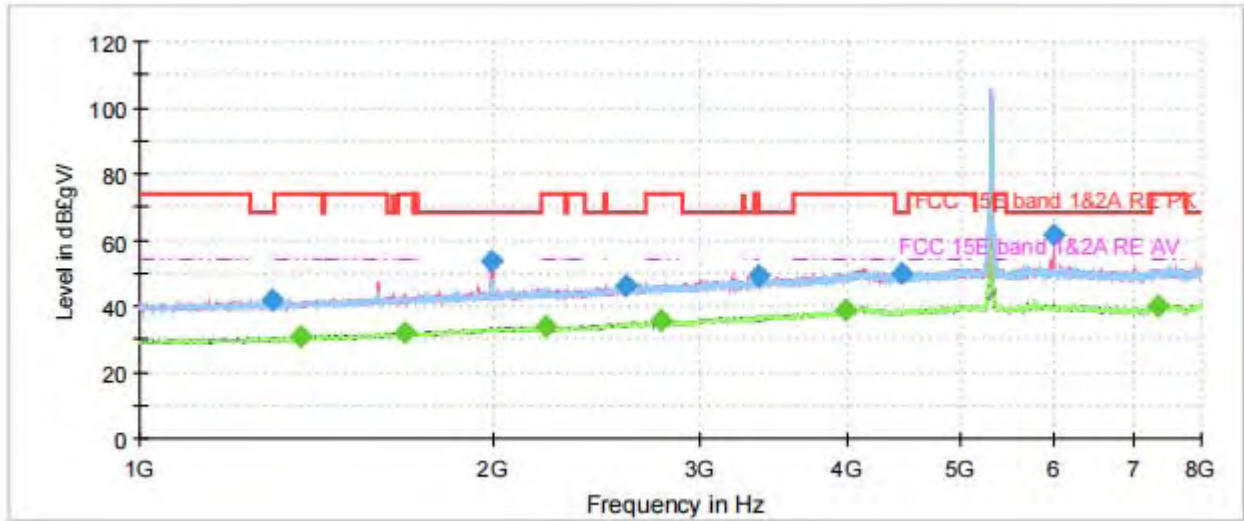

Note: The signal beyond the limit is carrier.
Radiates Emission from 1GHz to 8GHz

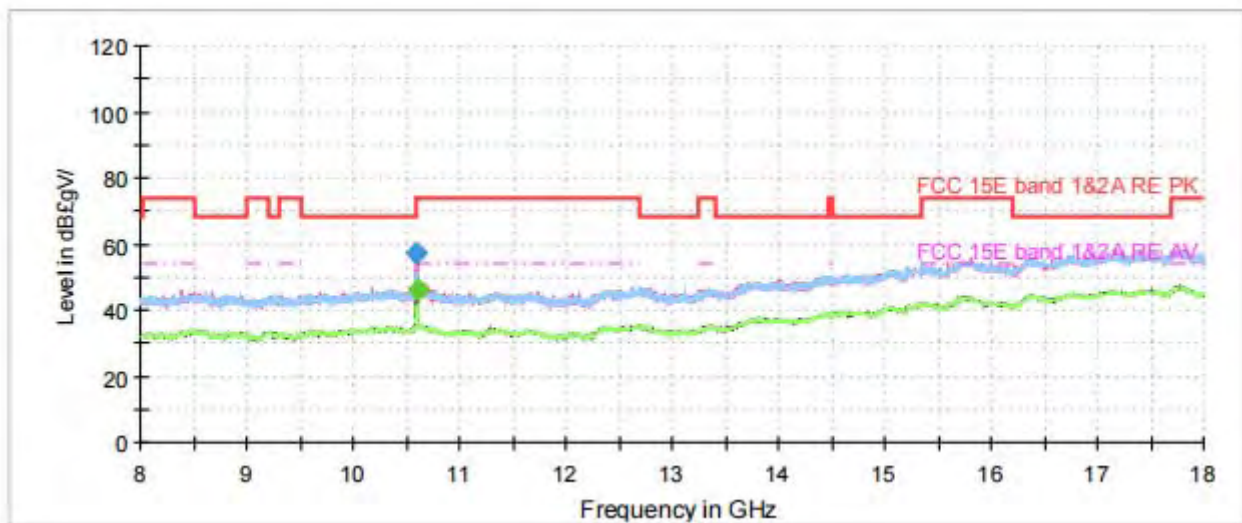

Radiates Emission from 8GHz to 18GHz



Frequency (MHz)	Peak (dBuV/m)	Average (dBuV/m)	Limit (dBuV/m)	Margin (dB)	Height (cm)	Polarization	Azimuth (deg)	Correct Factor (dB)
1294.000000	41.71	---	68.20	26.49	200.0	V	293.0	-6.8
1367.500000	---	30.92	54.00	23.08	100.0	V	74.0	-6.4
1679.875000	---	31.93	54.00	22.07	200.0	H	276.0	-4.6
1994.000000	53.68	---	68.20	14.52	100.0	V	359.0	-2.7
2213.625000	---	33.88	54.00	20.12	100.0	H	338.0	-1.7
2596.000000	46.19	---	68.20	22.01	200.0	V	0.0	0.0
2773.625000	---	35.40	54.00	18.60	100.0	V	110.0	0.8
3363.375000	49.24	---	68.20	18.96	200.0	V	185.0	3.3
3983.750000	---	38.71	54.00	15.29	100.0	V	1.0	6.1
4442.250000	49.86	---	68.20	18.34	200.0	V	293.0	6.3
5989.250000	61.32	---	68.20	6.88	100.0	V	337.0	9.7
7349.875000	---	40.05	54.00	13.95	200.0	H	0.0	11.5

Remark: 1. Correction Factor = Antenna factor+ Insertion loss (cable loss + amplifier gain)

802.11n (HT20) CH64

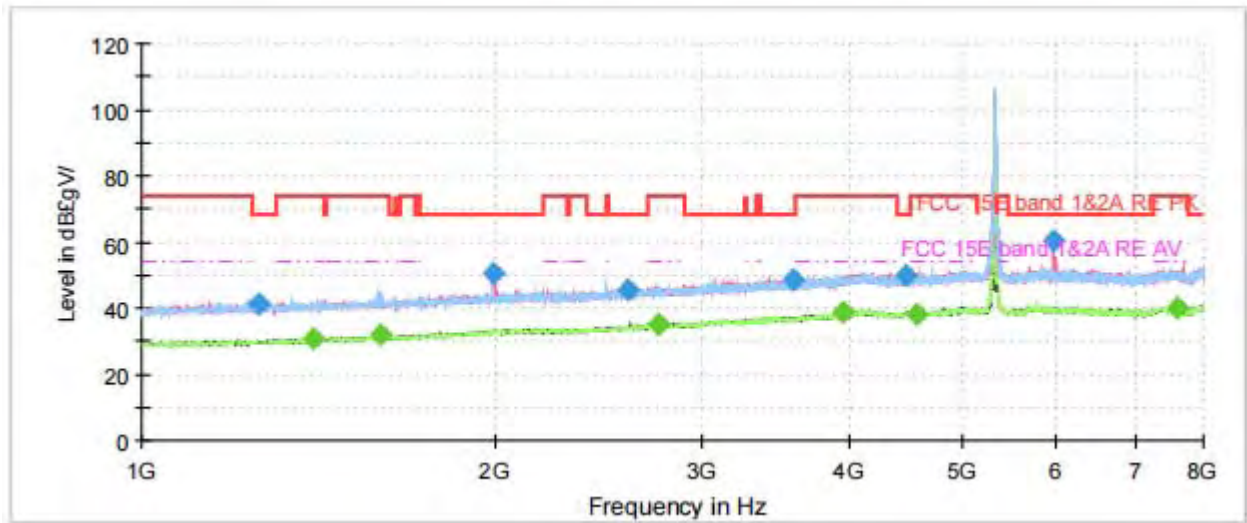

Note: The signal beyond the limit is carrier.
Radiates Emission from 1GHz to 8GHz

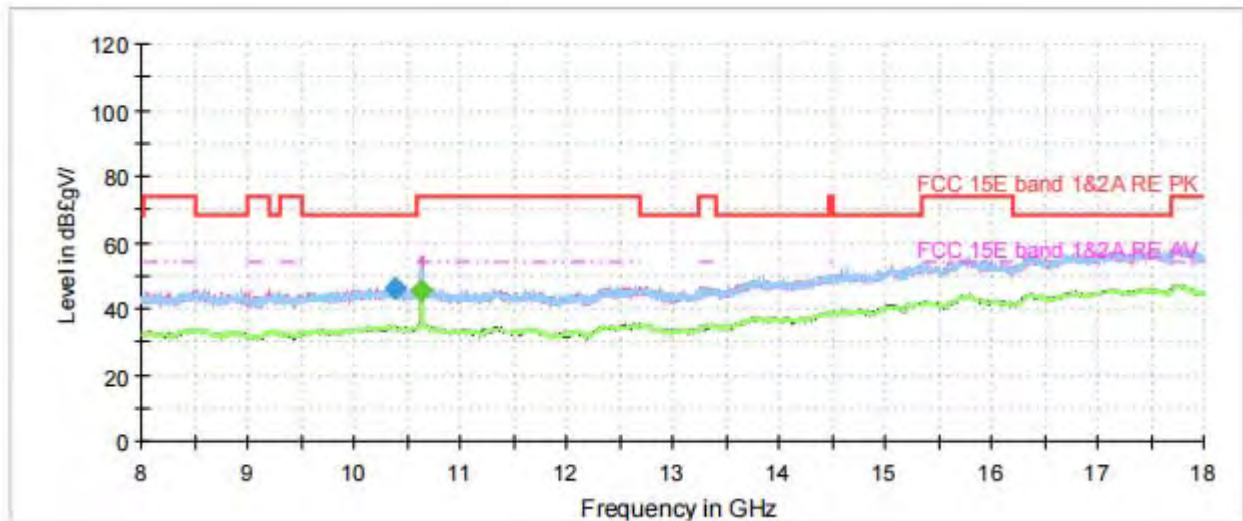

Radiates Emission from 8GHz to 18GHz



Frequency (MHz)	Peak (dBuV/m)	Average (dBuV/m)	Limit (dBuV/m)	Margin (dB)	Height (cm)	Polarization	Azimuth (deg)	Correct Factor (dB)
1259.000000	41.44	---	68.20	26.76	100.0	V	39.0	-7.0
1398.125000	---	30.54	54.00	23.46	100.0	H	329.0	-6.2
1596.750000	---	32.04	54.00	21.96	100.0	H	287.0	-5.1
1993.125000	50.44	---	68.20	17.76	100.0	H	0.0	-2.7
2596.000000	45.64	---	68.20	22.56	100.0	V	145.0	0.0
2757.000000	---	35.30	54.00	18.70	100.0	V	220.0	0.8
3576.000000	48.65	---	68.20	19.55	100.0	V	63.0	4.0
3947.875000	---	38.55	54.00	15.45	100.0	H	348.0	5.8
4465.875000	49.77	---	68.20	18.43	100.0	V	2.0	6.4
4556.000000	---	38.33	54.00	15.67	100.0	V	39.0	6.7
5976.125000	60.21	---	68.20	7.99	100.0	V	138.0	9.7
7615.000000	---	40.03	54.00	13.97	100.0	H	134.0	11.4

Remark: 1. Correction Factor = Antenna factor+ Insertion loss (cable loss + amplifier gain)

802.11n (HT20) CH100

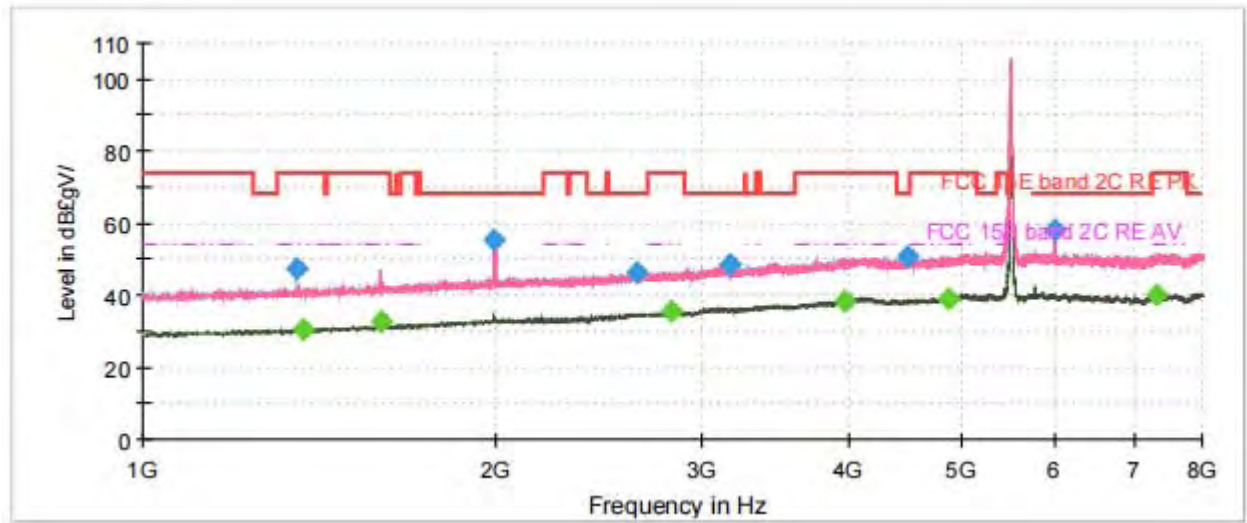

Note: The signal beyond the limit is carrier.
Radiates Emission from 1GHz to 8GHz

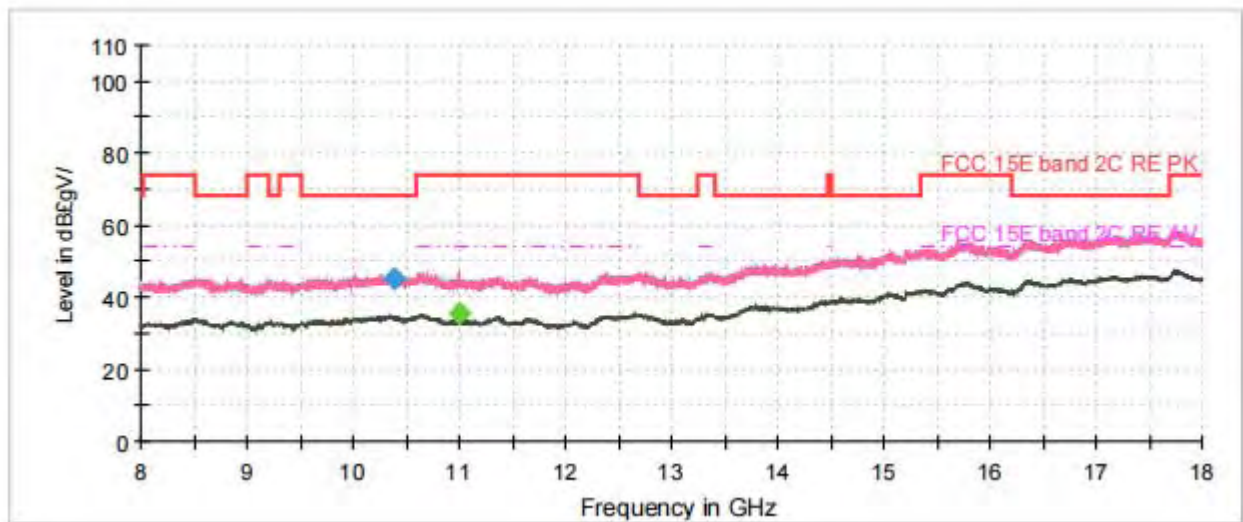

Radiates Emission from 8GHz to 18GHz



Frequency (MHz)	Peak (dBuV/m)	Average (dBuV/m)	Limit (dBuV/m)	Margin (dB)	Height (cm)	Polarization	Azimuth (deg)	Correct Factor (dB)
1352.625000	47.66	---	74.00	26.34	100.0	H	0.0	-6.5
1367.500000	---	30.71	54.00	23.29	200.0	H	133.0	-6.4
1598.500000	---	32.74	54.00	21.26	100.0	H	0.0	-5.1
1990.500000	55.39	---	68.20	12.81	100.0	V	284.0	-2.7
2642.375000	46.13	---	68.20	22.07	200.0	V	158.0	0.3
2818.250000	---	35.41	54.00	18.59	200.0	V	349.0	1.0
3169.125000	48.57	---	68.20	19.63	100.0	V	0.0	2.6
3966.250000	---	38.61	54.00	15.39	200.0	H	321.0	5.9
4478.125000	50.82	---	68.20	17.38	200.0	H	201.0	6.4
4866.625000	---	39.00	54.00	15.00	200.0	H	346.0	7.9
5998.875000	58.35	---	68.20	9.85	100.0	V	346.0	9.7
7331.500000	---	40.12	54.00	13.88	200.0	V	81.0	11.4

Remark: 1. Correction Factor = Antenna factor+ Insertion loss (cable loss + amplifier gain)

802.11n (HT20) CH116

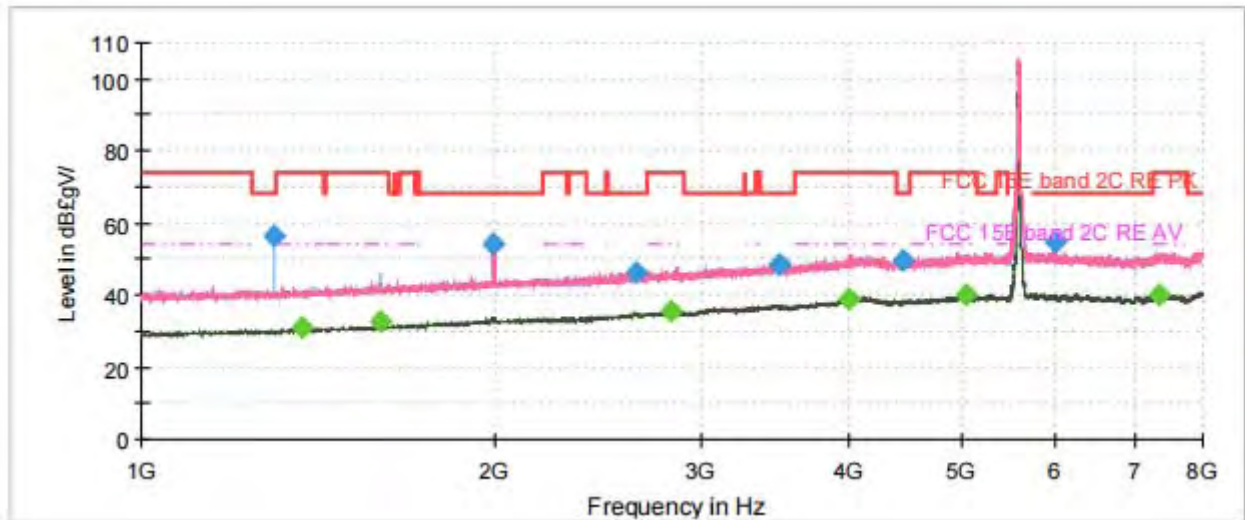

Note: The signal beyond the limit is carrier.
Radiates Emission from 1GHz to 8GHz

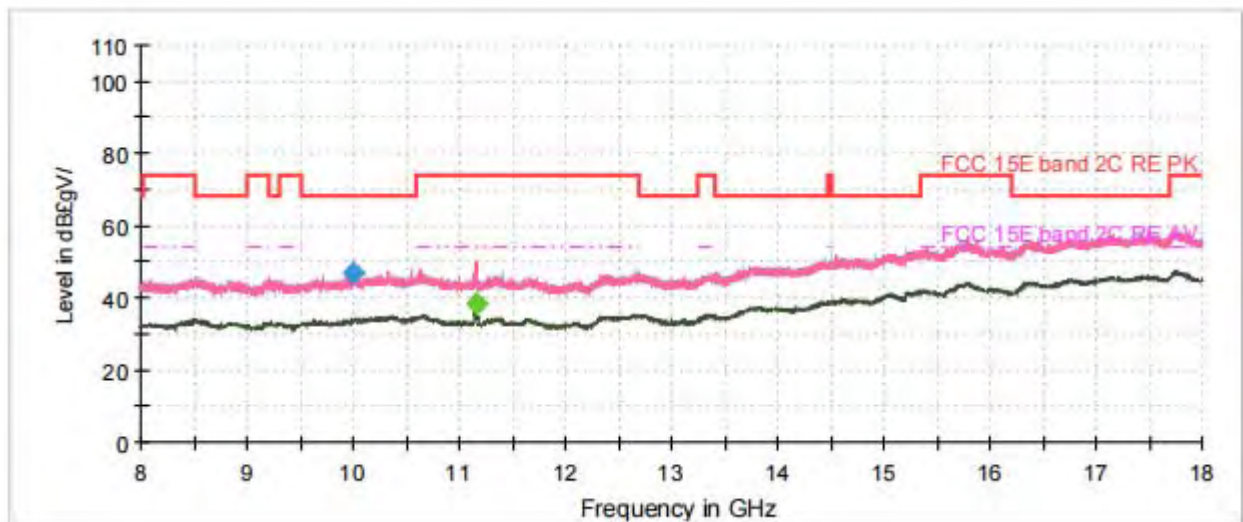

Radiates Emission from 8GHz to 18GHz



Frequency (MHz)	Peak (dBUV/m)	Average (dBUV/m)	Limit (dBUV/m)	Margin (dB)	Height (cm)	Polarization	Azimuth (deg)	Correct Factor (dB)
1296.625000	56.20	---	68.20	12.00	100.0	H	197.0	-6.8
1367.500000	---	30.85	54.00	23.15	200.0	H	312.0	-6.4
1594.125000	---	32.59	54.00	21.41	200.0	V	75.0	-5.1
1992.250000	54.10	---	68.20	14.10	200.0	V	340.0	-2.7
2637.125000	46.40	---	68.20	21.80	100.0	H	0.0	0.3
2827.875000	---	35.27	54.00	18.73	200.0	H	301.0	1.0
3486.750000	48.66	---	68.20	19.54	100.0	H	29.0	3.7
3992.500000	---	38.85	54.00	15.15	100.0	H	153.0	6.1
4452.750000	49.50	---	68.20	18.70	200.0	V	5.0	6.3
5038.125000	---	39.99	54.00	14.01	200.0	V	17.0	8.7
5978.750000	54.82	---	68.20	13.38	200.0	V	132.0	9.7
7351.625000	---	40.26	54.00	13.74	100.0	H	359.0	11.5

Remark: 1. Correction Factor = Antenna factor+ Insertion loss (cable loss + amplifier gain)

802.11n (HT20) CH140

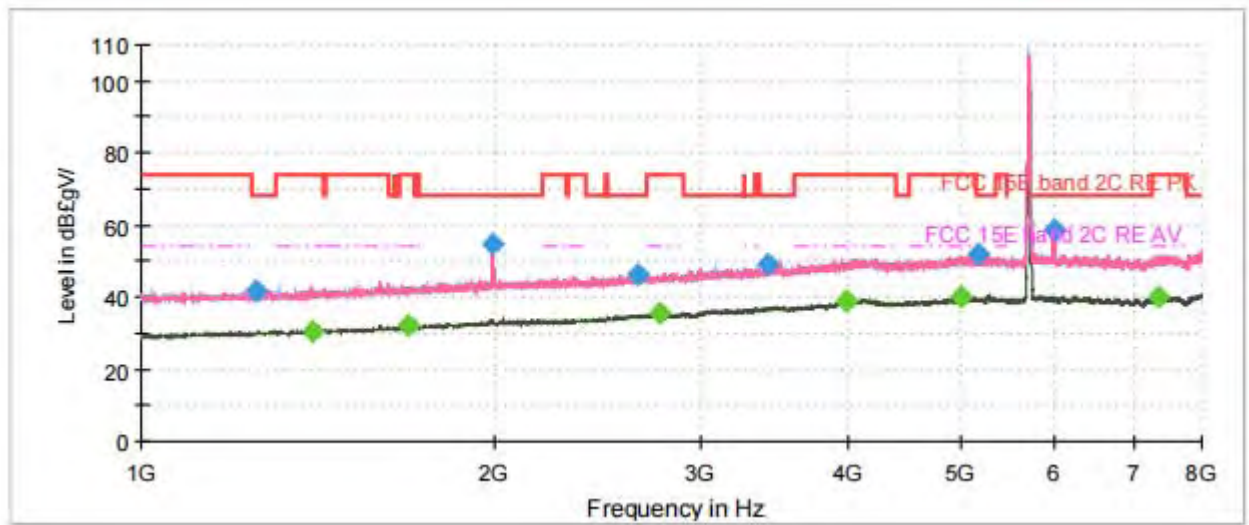

Note: The signal beyond the limit is carrier.
Radiates Emission from 1GHz to 8GHz

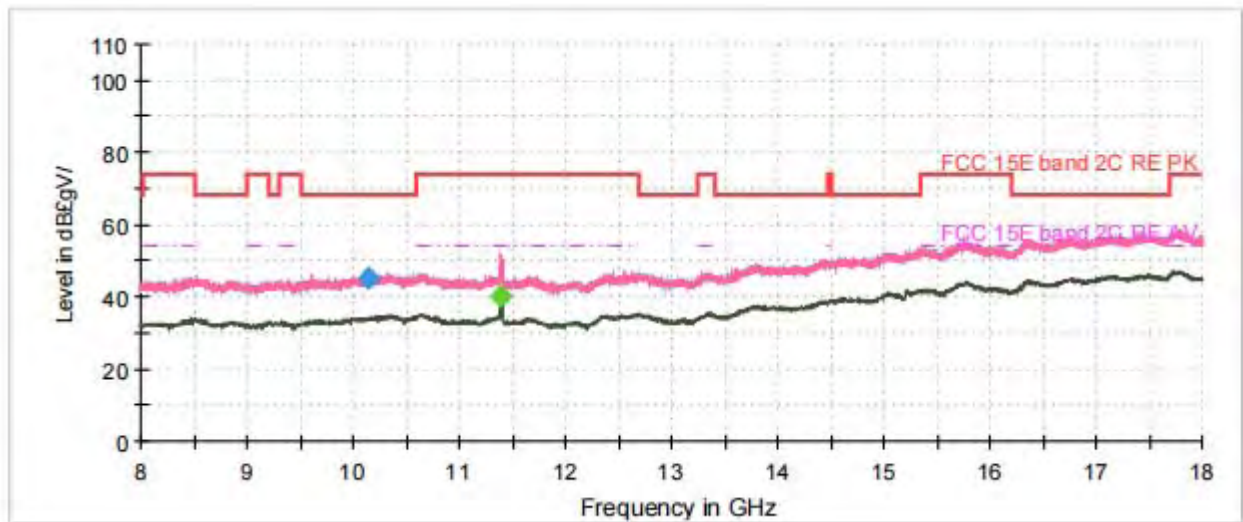

Radiates Emission from 8GHz to 18GHz



Frequency (MHz)	Peak (dBuV/m)	Average (dBuV/m)	Limit (dBuV/m)	Margin (dB)	Height (cm)	Polarization	Azimuth (deg)	Correct Factor (dB)
1254.625000	42.00	---	68.20	26.20	200.0	H	233.0	-7.0
1397.250000	---	30.70	54.00	23.30	200.0	H	161.0	-6.2
1684.250000	---	32.11	54.00	21.89	100.0	H	277.0	-4.6
1994.000000	54.54	---	68.20	13.66	100.0	V	343.0	-2.7
2650.250000	46.27	---	68.20	21.93	200.0	V	142.0	0.4
2768.375000	---	35.29	54.00	18.71	200.0	H	252.0	0.8
3423.750000	49.25	---	68.20	18.95	100.0	H	22.0	3.5
3983.750000	---	38.77	54.00	15.23	100.0	V	326.0	6.1
4999.625000	---	40.14	54.00	13.86	100.0	V	343.0	8.7
5164.125000	51.89	---	68.20	16.31	200.0	H	88.0	8.7
6000.625000	58.76	---	68.20	9.44	100.0	V	326.0	9.7
7358.625000	---	40.32	54.00	13.68	200.0	V	181.0	11.5

Remark: 1. Correction Factor = Antenna factor+ Insertion loss (cable loss + amplifier gain)

802.11n (HT20) CH149

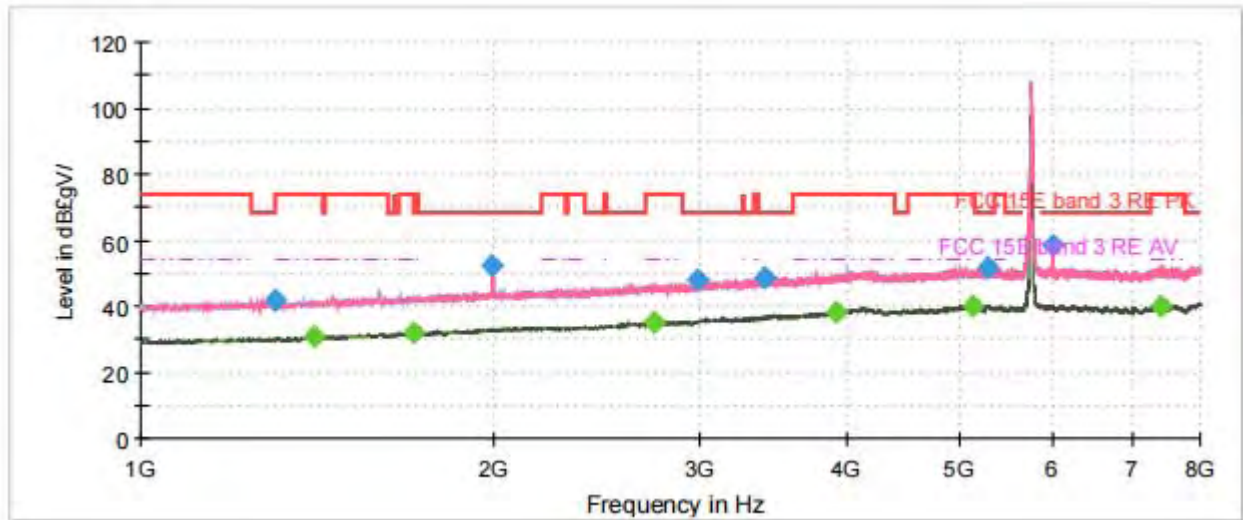

Note: The signal beyond the limit is carrier.
Radiates Emission from 1GHz to 8GHz

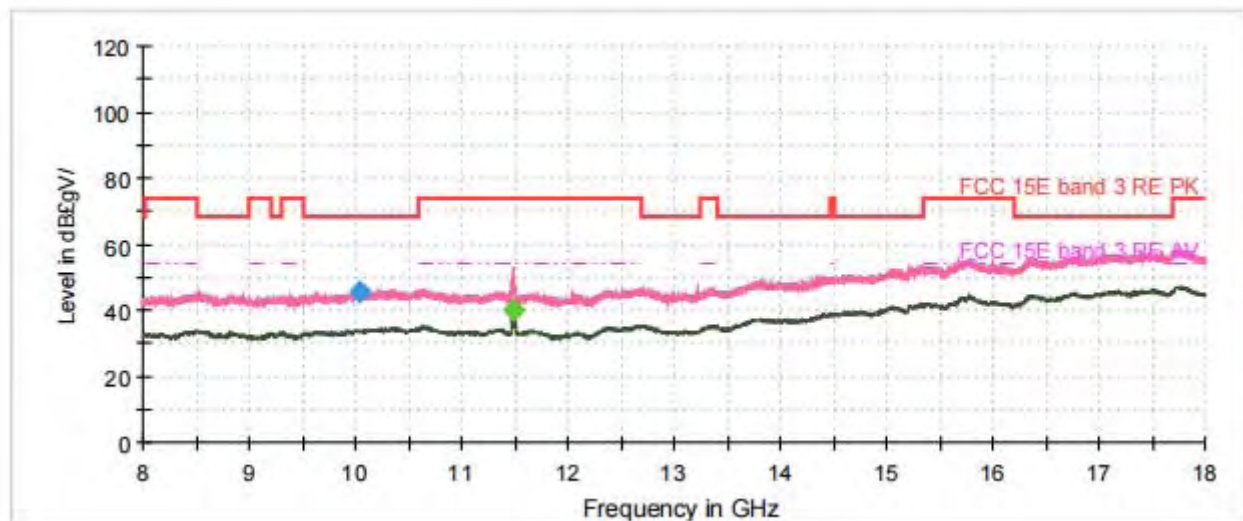

Radiates Emission from 8GHz to 18GHz



Frequency (MHz)	Peak (dBUV/m)	Average (dBUV/m)	Limit (dBUV/m)	Margin (dB)	Height (cm)	Polarization	Azimuth (deg)	Correct Factor (dB)
1299.250000	41.92	---	68.20	26.28	200.0	V	3.0	-6.8
1405.125000	---	31.04	54.00	22.96	200.0	V	328.0	-6.1
1707.000000	---	31.90	54.00	22.10	100.0	H	99.0	-4.4
1991.375000	52.28	---	68.20	15.92	200.0	V	187.0	-2.7
2738.625000	---	35.16	54.00	18.84	200.0	V	123.0	0.7
2981.875000	47.78	---	68.20	20.42	200.0	V	159.0	1.8
3397.500000	48.84	---	68.20	19.36	100.0	H	119.0	3.4
3923.375000	---	38.42	54.00	15.58	100.0	V	290.0	5.6
5123.875000	---	40.16	54.00	13.84	200.0	V	322.0	8.7
5272.625000	51.55	---	68.20	16.65	200.0	V	28.0	8.8
5984.875000	58.53	---	68.20	9.67	100.0	V	325.0	9.7
7416.375000	---	40.25	54.00	13.75	200.0	V	171.0	11.5

Remark: 1. Correction Factor = Antenna factor+ Insertion loss (cable loss + amplifier gain)

802.11n (HT20) CH157

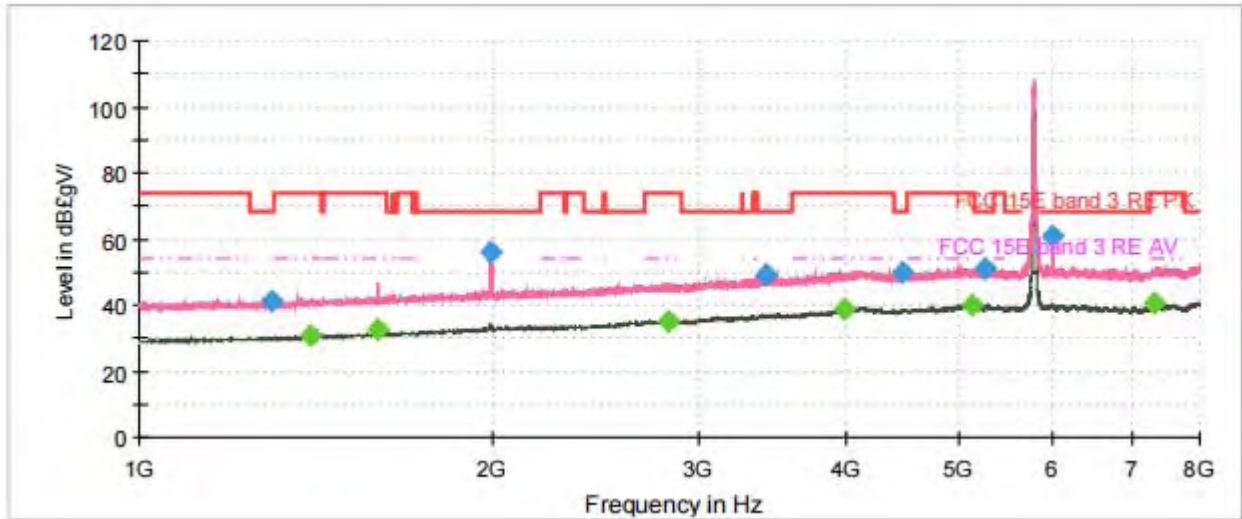

Note: The signal beyond the limit is carrier.
Radiates Emission from 1GHz to 8GHz

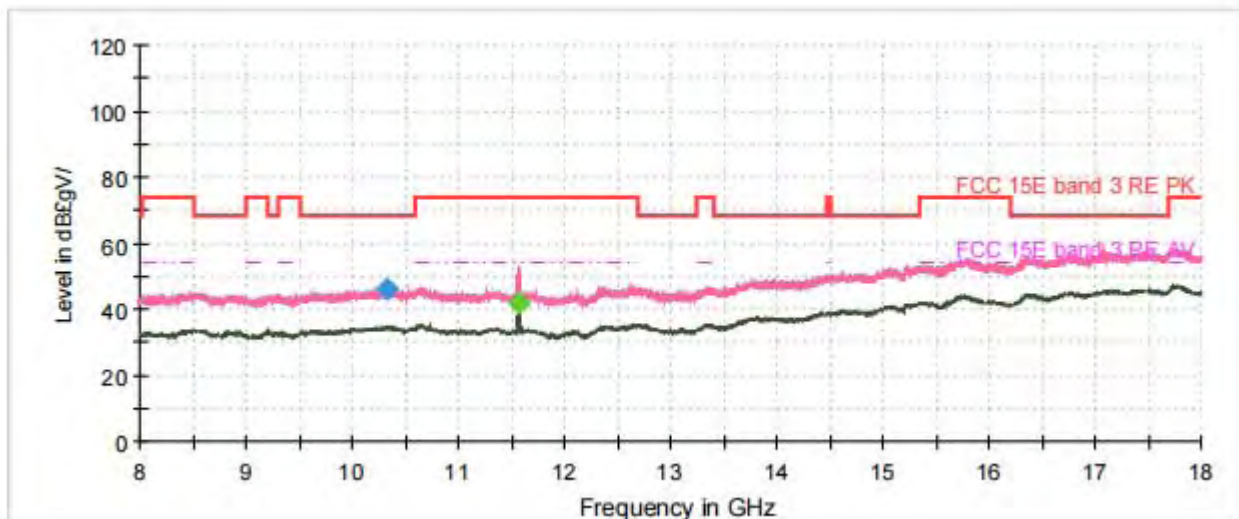

Radiates Emission from 8GHz to 18GHz



Frequency (MHz)	Peak (dBuV/m)	Average (dBuV/m)	Limit (dBuV/m)	Margin (dB)	Height (cm)	Polarization	Azimuth (deg)	Correct Factor (dB)
1296.625000	41.43	---	68.20	26.77	200.0	H	323.0	-6.8
1396.375000	---	30.66	54.00	23.34	100.0	H	122.0	-6.2
1595.875000	---	32.58	54.00	21.42	200.0	V	285.0	-5.1
1993.125000	56.11	---	68.20	12.09	100.0	V	231.0	-2.7
2819.125000	---	35.23	54.00	18.77	100.0	H	192.0	1.0
3412.375000	49.33	---	68.20	18.87	100.0	V	318.0	3.5
3987.250000	---	38.54	54.00	15.46	200.0	H	213.0	6.1
4461.500000	49.89	---	68.20	18.31	200.0	H	69.0	6.4
5122.125000	---	40.16	54.00	13.84	200.0	H	105.0	8.7
5256.000000	51.31	---	68.20	16.89	100.0	H	294.0	8.8
5986.625000	61.08	---	68.20	7.13	100.0	V	336.0	9.7
7322.750000	---	40.72	54.00	13.28	100.0	H	353.0	11.4

Remark: 1. Correction Factor = Antenna factor+ Insertion loss (cable loss + amplifier gain)

802.11n (HT20) CH165

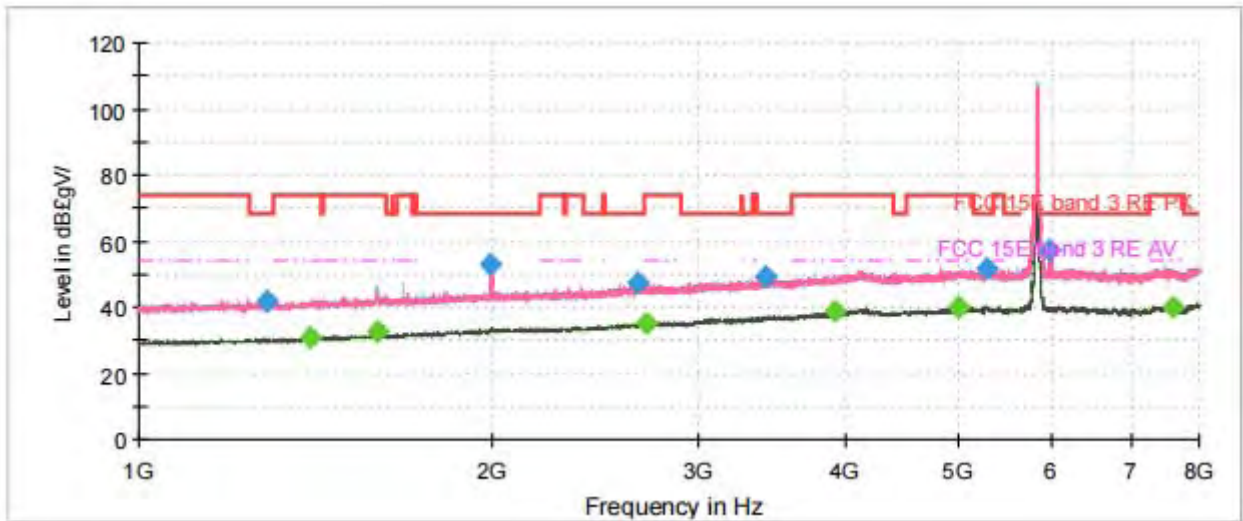

Note: The signal beyond the limit is carrier.
Radiates Emission from 1GHz to 8GHz

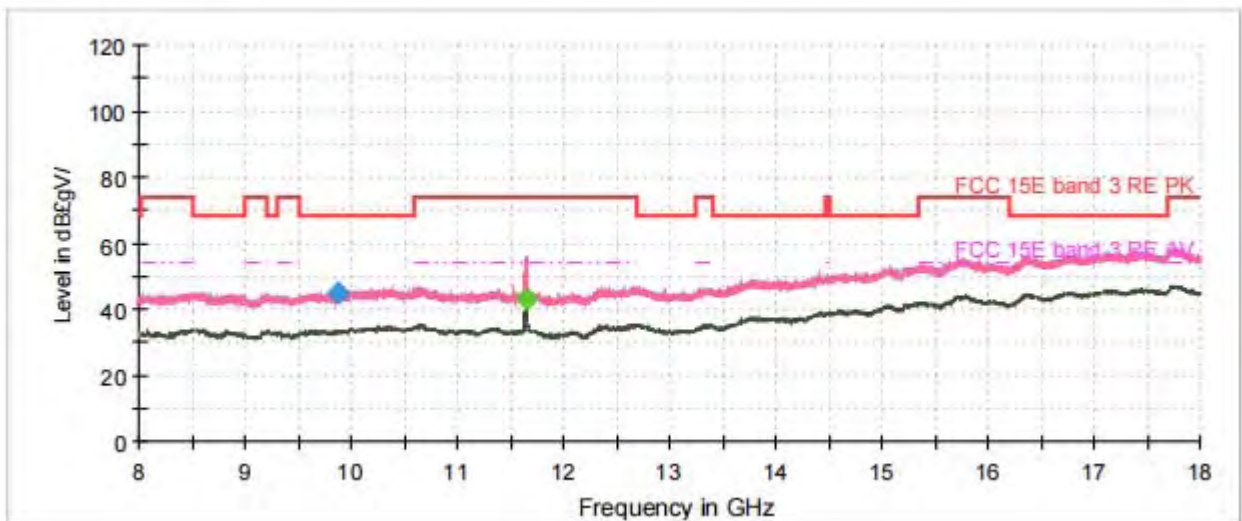

Radiates Emission from 8GHz to 18GHz



Frequency (MHz)	Peak (dBuV/m)	Average (dBuV/m)	Limit (dBuV/m)	Margin (dB)	Height (cm)	Polarization	Azimuth (deg)	Correct Factor (dB)
1282.625000	41.59	---	68.20	26.61	200.0	H	51.0	-6.8
1398.125000	---	30.80	54.00	23.20	100.0	V	291.0	-6.2
1594.125000	---	32.52	54.00	21.48	200.0	V	243.0	-5.1
1993.125000	52.92	---	68.20	15.28	100.0	V	302.0	-2.7
2653.750000	47.15	---	68.20	21.05	100.0	V	191.0	0.4
2704.500000	---	35.24	54.00	18.76	100.0	V	208.0	0.6
3413.250000	49.32	---	68.20	18.88	100.0	V	111.0	3.5
3914.625000	---	38.60	54.00	15.40	100.0	V	65.0	5.6
4997.000000	---	40.00	54.00	14.00	200.0	H	208.0	8.7
5283.125000	51.45	---	68.20	16.75	200.0	V	207.0	8.8
5975.250000	57.17	---	68.20	11.03	100.0	V	215.0	9.7
7615.000000	---	40.24	54.00	13.76	200.0	V	284.0	11.4

Remark: 1. Correction Factor = Antenna factor+ Insertion loss (cable loss + amplifier gain)

802.11n (HT40) CH38

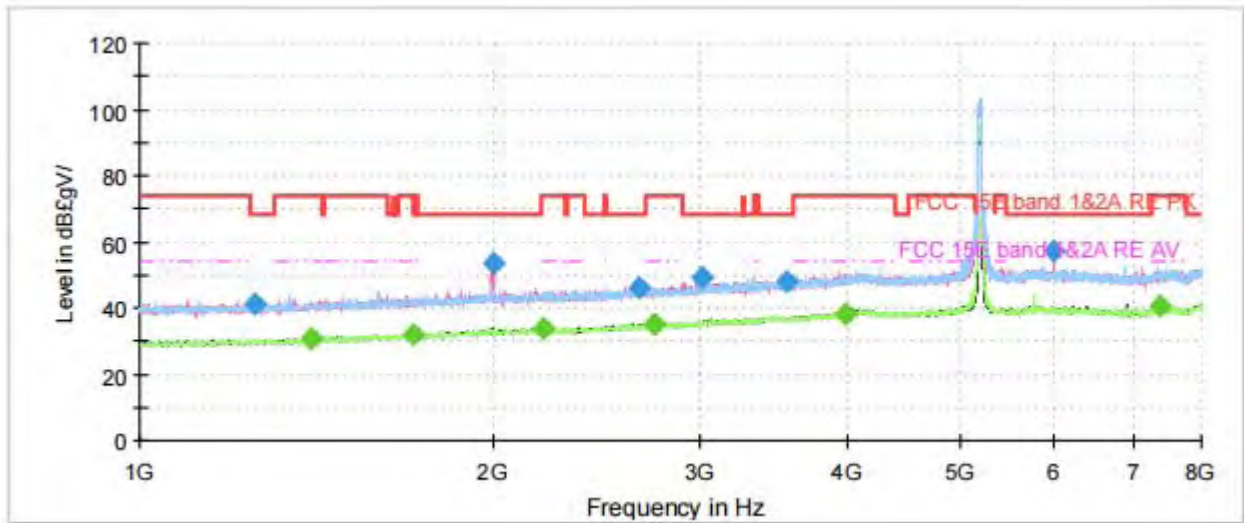

Note: The signal beyond the limit is carrier.
Radiates Emission from 1GHz to 8GHz

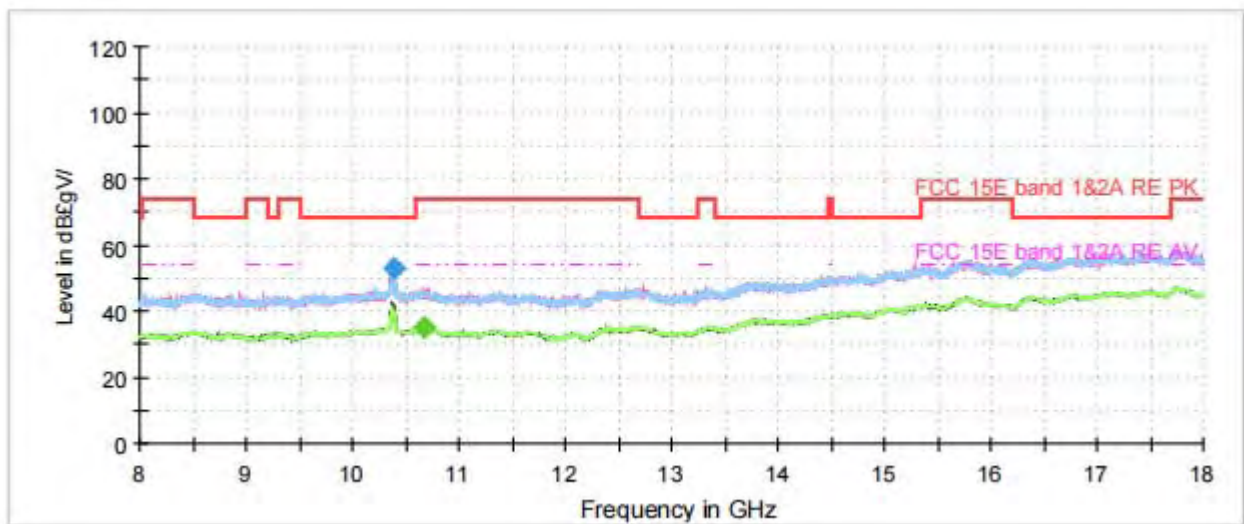

Radiates Emission from 8GHz to 18GHz



Frequency (MHz)	Peak (dBuV/m)	Average (dBuV/m)	Limit (dBuV/m)	Margin (dB)	Height (cm)	Polarization	Azimuth (deg)	Correct Factor (dB)
1254.625000	41.42	---	68.20	26.78	100.0	H	353.0	-7.0
1397.250000	---	30.97	54.00	23.03	100.0	H	179.0	-6.2
1705.250000	---	31.74	54.00	22.26	100.0	V	162.0	-4.5
1996.625000	53.25	---	68.20	14.95	100.0	V	247.0	-2.7
2207.500000	---	33.64	54.00	20.36	100.0	V	97.0	-1.8
2655.500000	46.33	---	68.20	21.87	100.0	V	151.0	0.4
2737.750000	---	35.16	54.00	18.84	100.0	V	3.0	0.7
3002.875000	49.13	---	68.20	19.07	100.0	H	246.0	2.0
3552.375000	48.09	---	68.20	20.11	100.0	V	313.0	3.9
3984.625000	---	38.37	54.00	15.63	100.0	V	174.0	6.1
5989.250000	57.06	---	68.20	11.14	100.0	V	79.0	9.7
7387.500000	---	40.32	54.00	13.68	100.0	H	144.0	11.5

Remark: 1. Correction Factor = Antenna factor+ Insertion loss (cable loss + amplifier gain)

802.11n (HT40) CH46

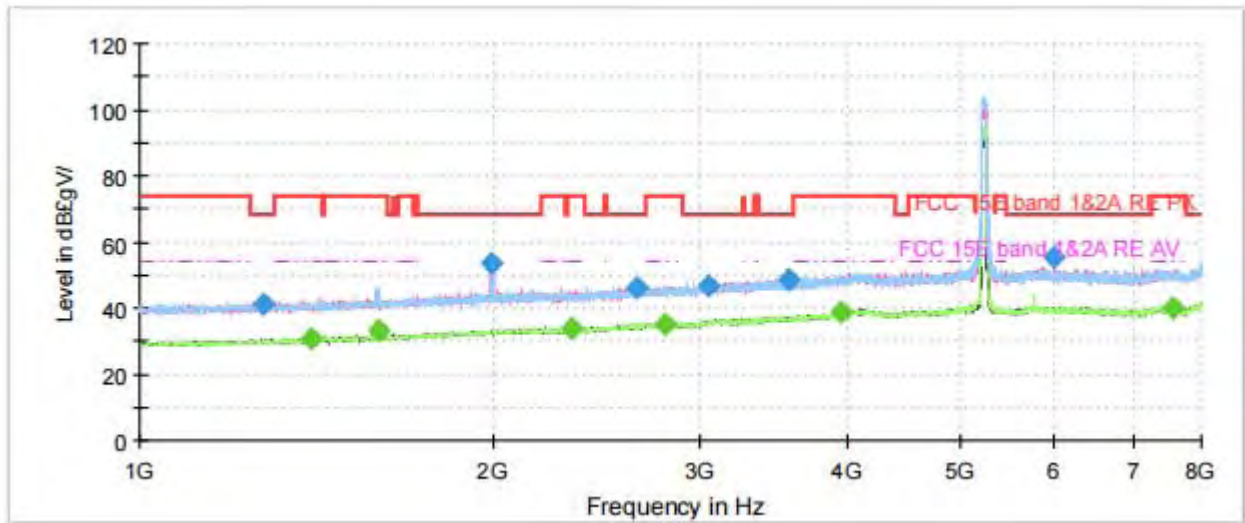

Note: The signal beyond the limit is carrier.
Radiates Emission from 1GHz to 8GHz

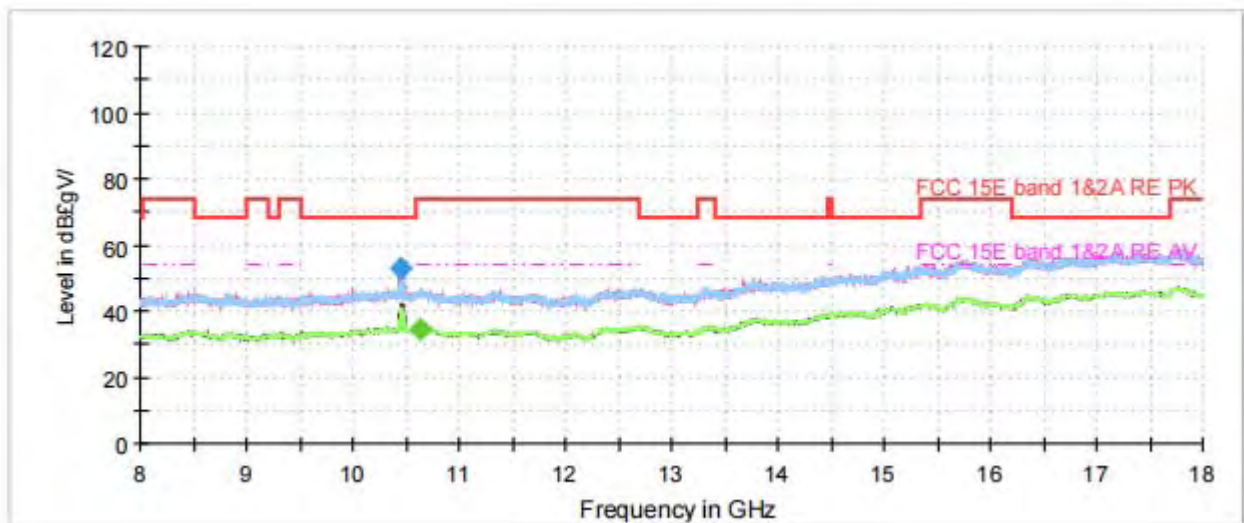

Radiates Emission from 8GHz to 18GHz



Frequency (MHz)	Peak (dBuV/m)	Average (dBuV/m)	Limit (dBuV/m)	Margin (dB)	Height (cm)	Polarization	Azimuth (deg)	Correct Factor (dB)
1273.875000	41.29	---	68.20	26.91	100.0	H	341.0	-6.9
1397.250000	---	30.97	54.00	23.03	100.0	V	81.0	-6.2
1596.750000	---	33.47	54.00	20.53	100.0	H	4.0	-5.1
1995.750000	53.25	---	68.20	14.95	100.0	V	3.0	-2.7
2335.250000	---	33.66	54.00	20.34	100.0	H	241.0	-1.4
2643.250000	46.07	---	68.20	22.13	100.0	V	111.0	0.3
2798.125000	---	35.31	54.00	18.69	100.0	V	111.0	0.9
3041.375000	46.93	---	68.20	21.27	100.0	H	247.0	2.2
3560.250000	48.69	---	68.20	19.51	100.0	V	9.0	3.9
3941.750000	---	38.84	54.00	15.16	100.0	V	267.0	5.7
5988.375000	55.57	---	68.20	12.63	100.0	V	0.0	9.7
7562.500000	---	40.18	54.00	13.82	100.0	H	210.0	11.4

Remark: 1. Correction Factor = Antenna factor+ Insertion loss (cable loss + amplifier gain)

802.11n (HT40) CH54

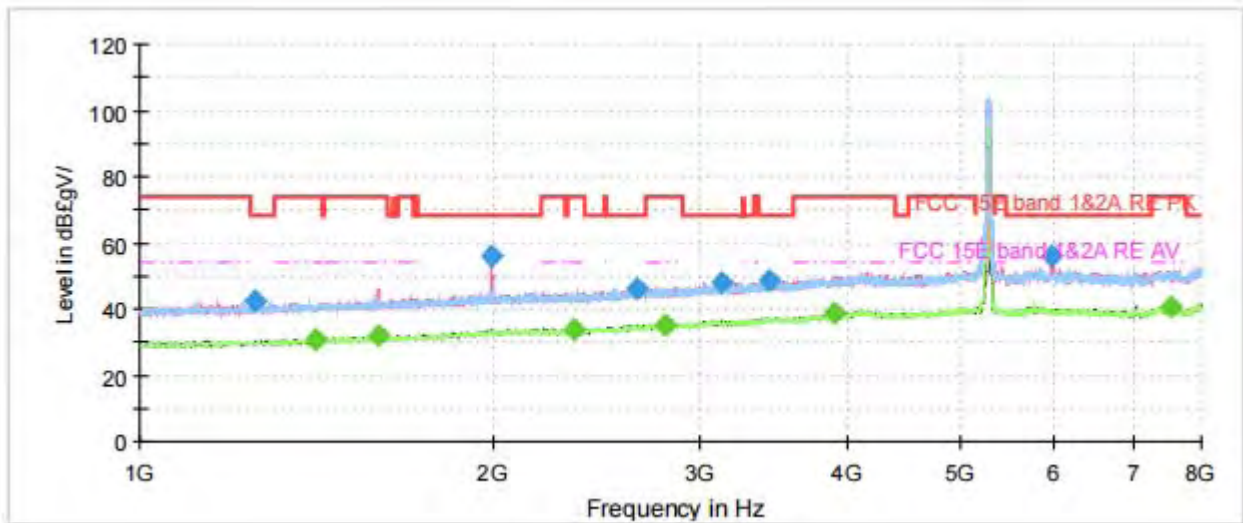

Note: The signal beyond the limit is carrier.
Radiates Emission from 1GHz to 8GHz

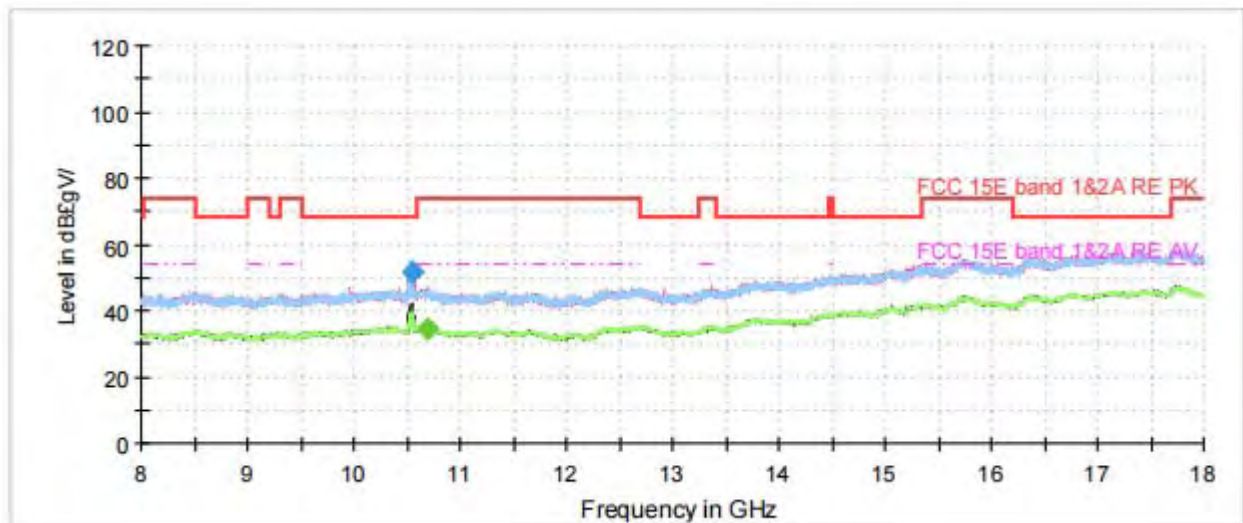

Radiates Emission from 8GHz to 18GHz



Frequency (MHz)	Peak (dBuV/m)	Average (dBuV/m)	Limit (dBuV/m)	Margin (dB)	Height (cm)	Polarization	Azimuth (deg)	Correct Factor (dB)
1251.125000	42.23	---	68.20	25.97	100.0	H	334.0	-7.0
1413.875000	---	30.74	54.00	23.26	100.0	V	115.0	-6.1
1595.875000	---	32.16	54.00	21.84	100.0	V	276.0	-5.1
1994.875000	56.09	---	68.20	12.11	100.0	V	356.0	-2.7
2336.125000	---	33.55	54.00	20.45	100.0	V	231.0	-1.4
2645.875000	46.44	---	68.20	21.76	100.0	H	340.0	0.3
2804.250000	---	35.27	54.00	18.73	100.0	V	0.0	0.9
3127.125000	47.98	---	68.20	20.22	100.0	V	54.0	2.5
3437.750000	48.53	---	68.20	19.67	100.0	V	170.0	3.5
3905.000000	---	38.56	54.00	15.44	100.0	H	300.0	5.5
5976.125000	56.15	---	68.20	12.05	100.0	V	262.0	9.7
7545.875000	---	40.39	54.00	13.61	100.0	V	0.0	11.5

Remark: 1. Correction Factor = Antenna factor+ Insertion loss (cable loss + amplifier gain)

802.11n (HT40) CH62

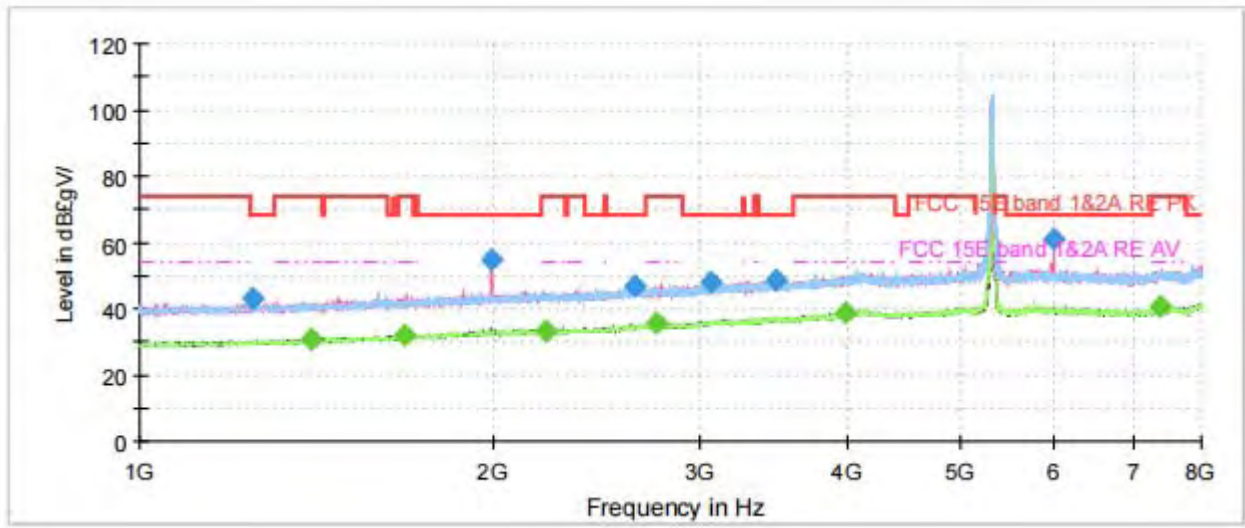

Note: The signal beyond the limit is carrier.
Radiates Emission from 1GHz to 8GHz

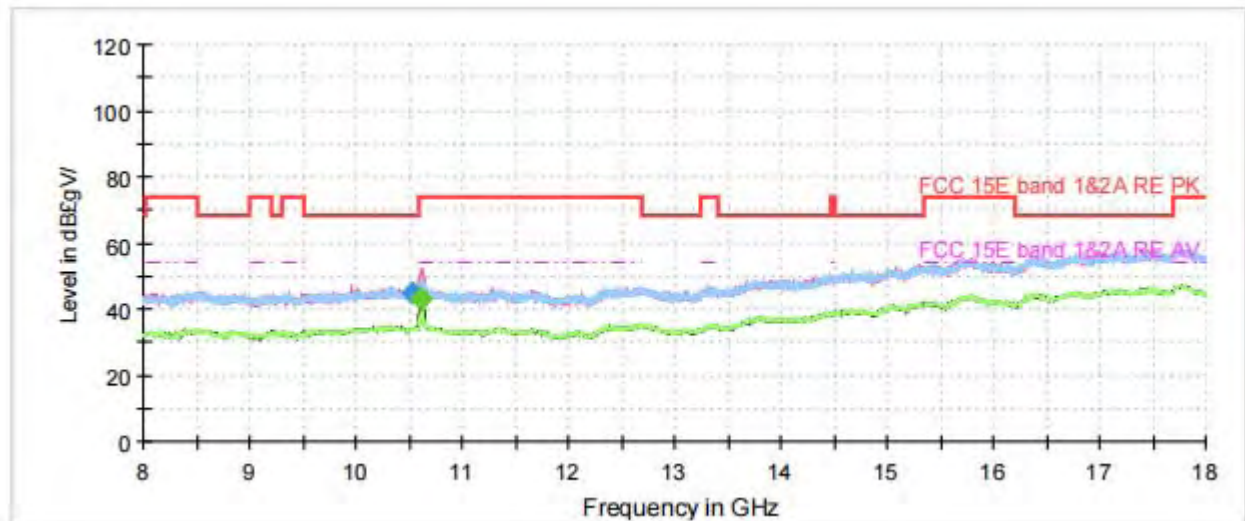

Radiates Emission from 8GHz to 18GHz



Frequency (MHz)	Peak (dBuV/m)	Average (dBuV/m)	Limit (dBuV/m)	Margin (dB)	Height (cm)	Polarization	Azimuth (deg)	Correct Factor (dB)
1245.000000	42.97	---	68.20	25.23	100.0	H	339.0	-7.0
1400.750000	---	30.70	54.00	23.30	100.0	V	9.0	-6.2
1683.375000	---	32.00	54.00	22.00	100.0	H	67.0	-4.6
1995.750000	54.55	---	68.20	13.65	100.0	V	0.0	-2.7
2218.875000	---	33.24	54.00	20.76	100.0	V	40.0	-1.7
2637.125000	46.82	---	68.20	21.38	100.0	V	148.0	0.3
2747.375000	---	35.41	54.00	18.59	100.0	V	70.0	0.7
3065.875000	48.09	---	68.20	20.11	100.0	V	3.0	2.4
3474.500000	48.36	---	68.20	19.84	100.0	V	256.0	3.7
3979.375000	---	38.68	54.00	15.32	100.0	H	213.0	6.0
5987.500000	60.92	---	68.20	7.28	100.0	V	339.0	9.7
7363.875000	---	40.38	54.00	13.62	100.0	H	122.0	11.5

Remark: 1. Correction Factor = Antenna factor+ Insertion loss (cable loss + amplifier gain)

802.11n (HT40) CH102

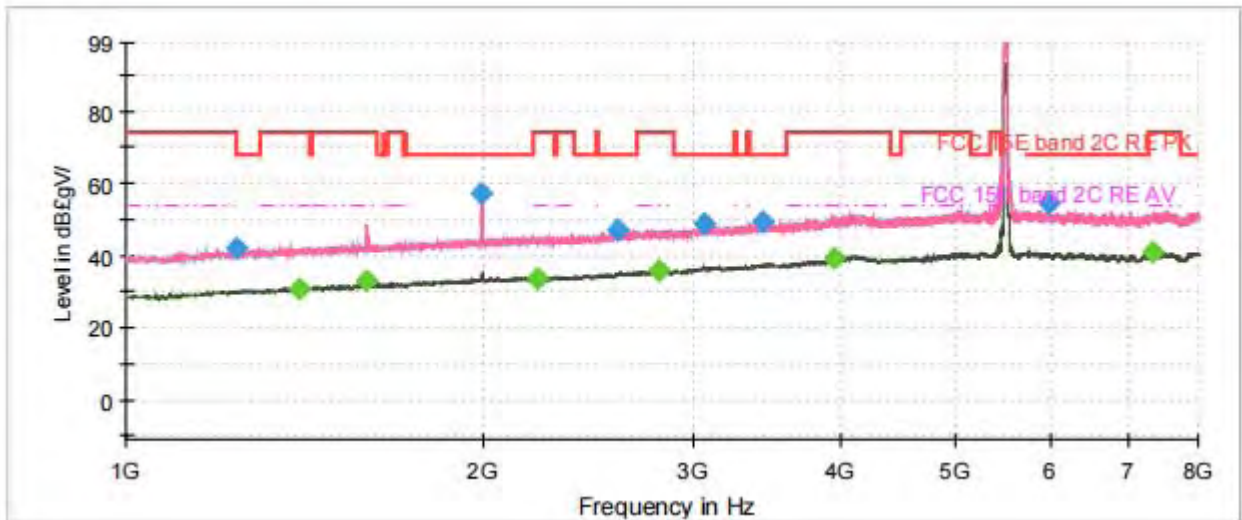

Note: The signal beyond the limit is carrier.
Radiates Emission from 1GHz to 8GHz

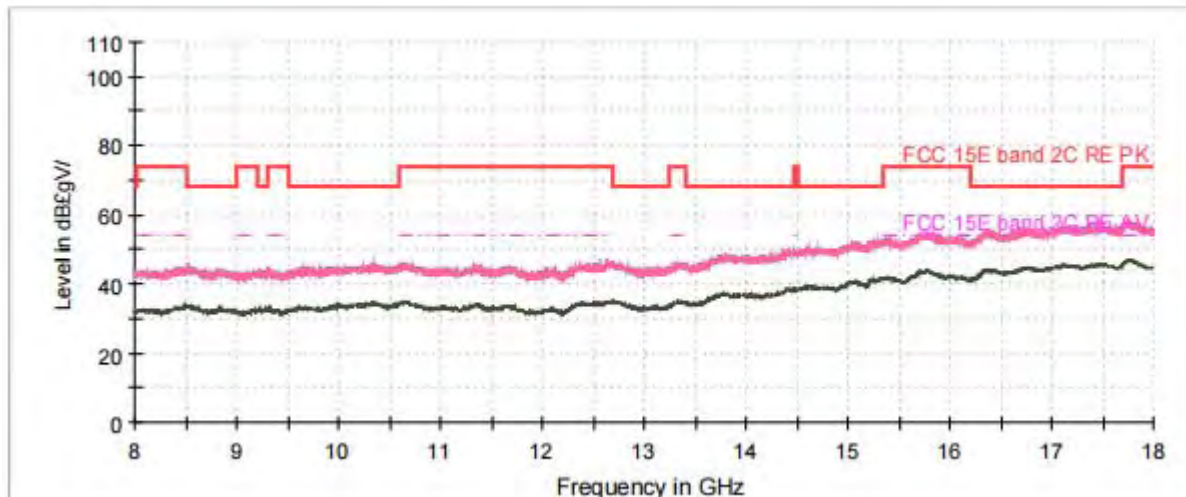

Radiates Emission from 8GHz to 18GHz



Frequency (MHz)	Peak (dBuV/m)	Average (dBuV/m)	Limit (dBuV/m)	Margin (dB)	Height (cm)	Polarization	Azimuth (deg)	Correct Factor (dB)
1241.500000	42.26	---	68.20	25.94	100.0	H	207.0	-7.1
1399.875000	---	31.00	54.00	23.00	200.0	V	45.0	-6.2
1592.375000	---	32.82	54.00	21.18	200.0	H	4.0	-5.1
1995.750000	57.14	---	68.20	11.06	200.0	V	285.0	-2.7
2222.375000	---	33.67	54.00	20.33	100.0	H	70.0	-1.7
2594.250000	47.17	---	68.20	21.03	200.0	V	106.0	0.0
2805.125000	---	35.92	54.00	18.08	100.0	V	321.0	1.0
3064.125000	48.60	---	68.20	19.60	100.0	V	0.0	2.4
3434.250000	49.09	---	68.20	19.11	200.0	V	94.0	3.5
3946.125000	---	39.12	54.00	14.88	100.0	V	174.0	5.8
5996.250000	54.67	---	68.20	13.53	200.0	V	3.0	9.7
7339.375000	---	40.82	54.00	13.18	100.0	V	253.0	11.4

Remark: 1. Correction Factor = Antenna factor+ Insertion loss (cable loss + amplifier gain)

802.11n (HT40) CH118

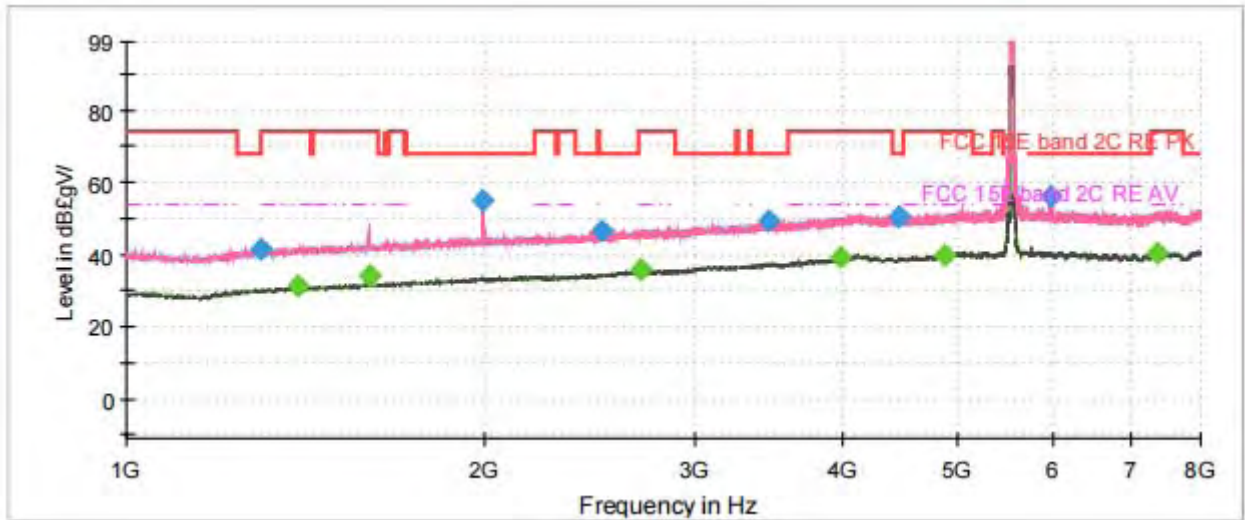

Note: The signal beyond the limit is carrier.
Radiates Emission from 1GHz to 8GHz

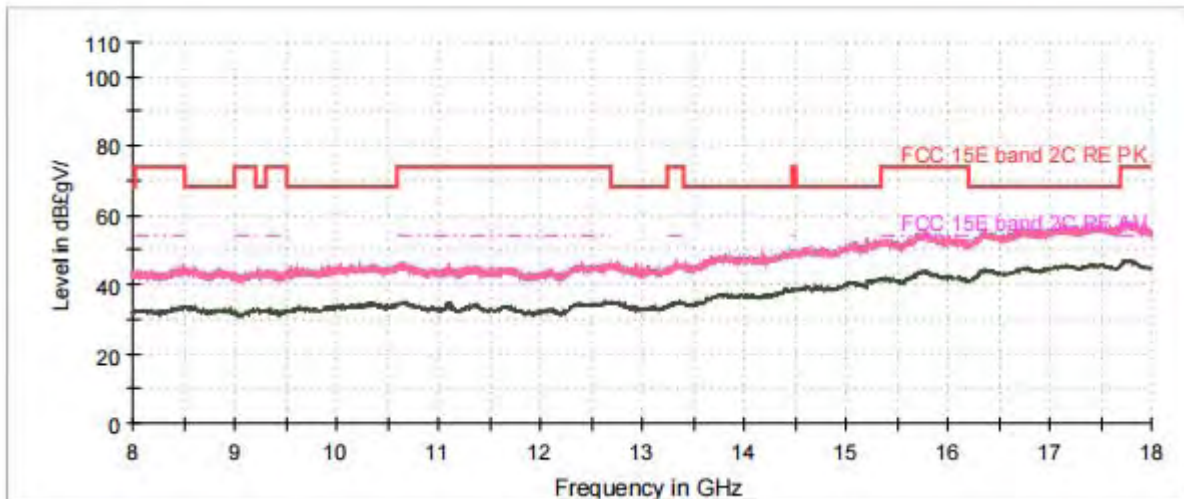

Radiates Emission from 8GHz to 18GHz



Frequency (MHz)	Peak (dBuV/m)	Average (dBuV/m)	Limit (dBuV/m)	Margin (dB)	Height (cm)	Polarization	Azimuth (deg)	Correct Factor (dB)
1297.500000	41.63	---	68.20	26.57	100.0	H	345.0	-6.8
1396.375000	---	31.21	54.00	22.79	100.0	V	324.0	-6.2
1598.500000	---	33.94	54.00	20.06	200.0	V	276.0	-5.1
1995.750000	54.79	---	68.20	13.41	100.0	V	0.0	-2.7
2509.375000	46.69	---	68.20	21.51	200.0	H	130.0	-0.6
2708.875000	---	35.59	54.00	18.41	200.0	H	217.0	0.6
3468.375000	49.49	---	68.20	18.71	100.0	H	22.0	3.6
3980.250000	---	38.94	54.00	15.06	100.0	V	157.0	6.0
4459.750000	50.42	---	68.20	17.78	200.0	V	96.0	6.4
4870.125000	---	39.89	54.00	14.11	200.0	H	205.0	7.9
5988.375000	56.28	---	68.20	11.92	100.0	V	300.0	9.7
7362.125000	---	40.57	54.00	13.43	100.0	V	140.0	11.5

Remark: 1. Correction Factor = Antenna factor+ Insertion loss (cable loss + amplifier gain)

802.11n (HT40) CH134

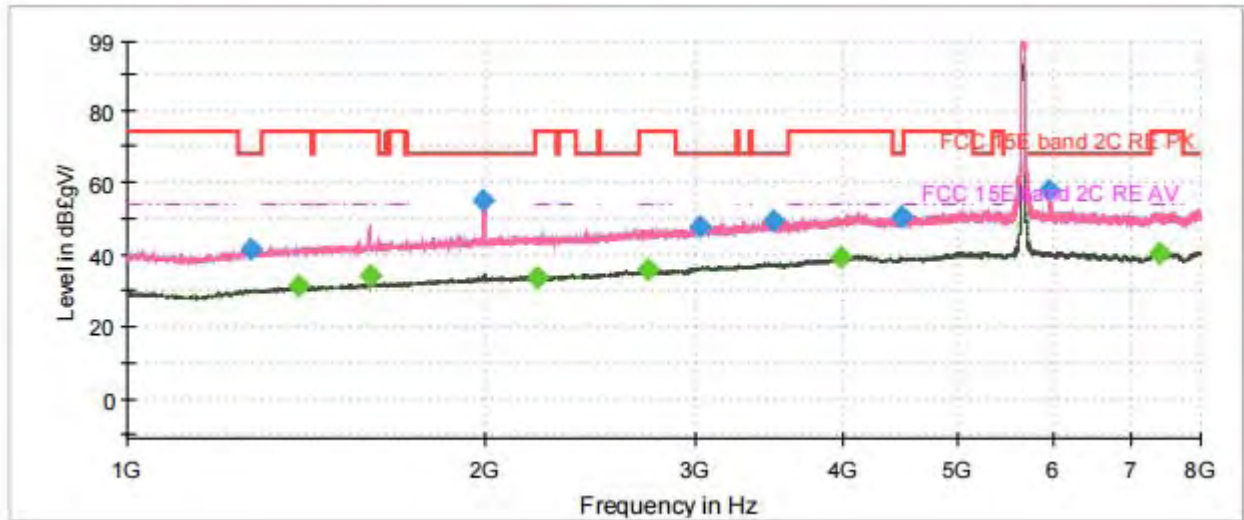

Note: The signal beyond the limit is carrier.
Radiates Emission from 1GHz to 8GHz

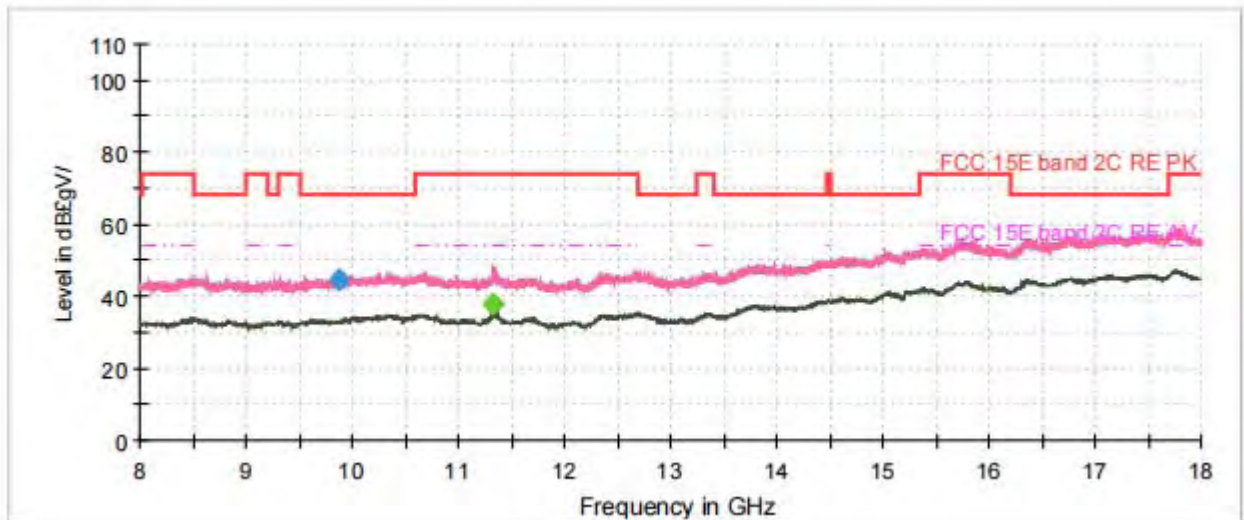

Radiates Emission from 8GHz to 18GHz



Frequency (MHz)	Peak (dBuV/m)	Average (dBuV/m)	Limit (dBuV/m)	Margin (dB)	Height (cm)	Polarization	Azimuth (deg)	Correct Factor (dB)
1270.375000	41.65	---	68.20	26.55	100.0	V	306.0	-6.9
1393.750000	---	31.05	54.00	22.95	100.0	V	293.0	-6.2
1598.500000	---	34.19	54.00	19.81	200.0	V	279.0	-5.1
1994.000000	55.11	---	68.20	13.09	200.0	V	106.0	-2.7
2212.750000	---	33.69	54.00	20.31	100.0	V	253.0	-1.7
2745.625000	---	35.60	54.00	18.40	100.0	V	244.0	0.7
3037.000000	47.69	---	68.20	20.51	100.0	H	167.0	2.2
3501.625000	49.51	---	68.20	18.69	100.0	H	343.0	3.7
3989.000000	---	39.05	54.00	14.95	100.0	H	167.0	6.1
4473.750000	50.50	---	68.20	17.70	100.0	V	312.0	6.4
5974.375000	57.80	---	68.20	10.40	100.0	V	347.0	9.7
7380.500000	---	40.42	54.00	13.58	200.0	V	255.0	11.5

Remark: 1. Correction Factor = Antenna factor+ Insertion loss (cable loss + amplifier gain)

802.11n (HT40) CH151

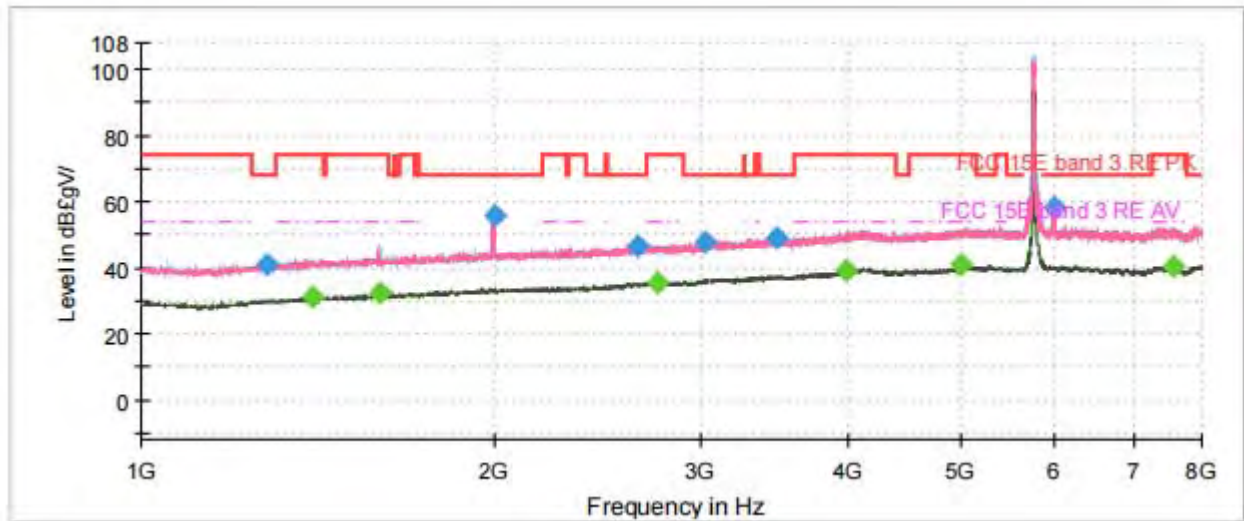

Note: The signal beyond the limit is carrier.
Radiates Emission from 1GHz to 8GHz

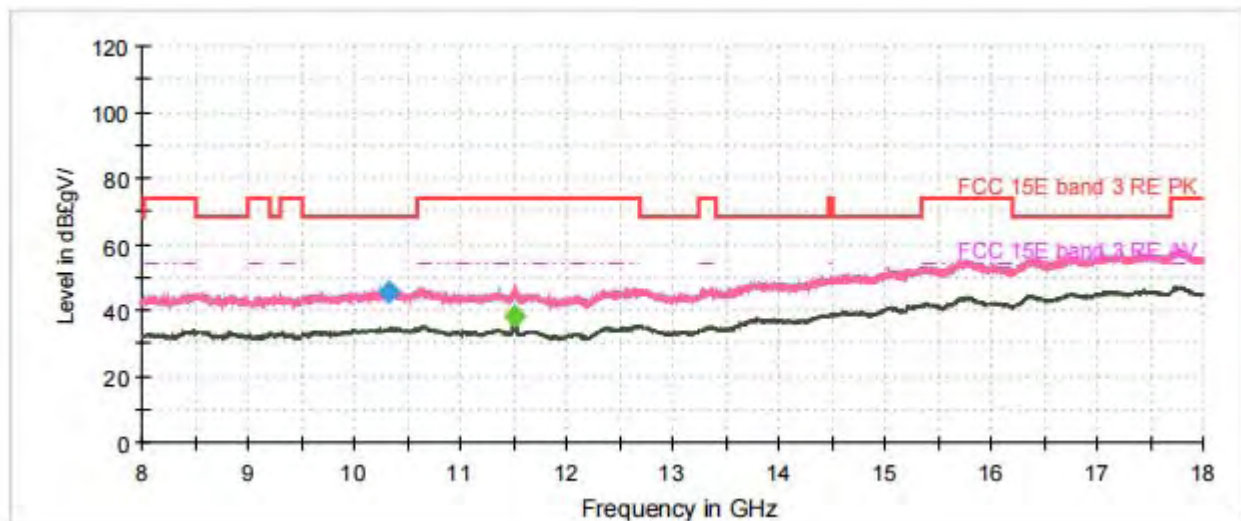

Radiates Emission from 8GHz to 18GHz



Frequency (MHz)	Peak (dBuV/m)	Average (dBuV/m)	Limit (dBuV/m)	Margin (dB)	Height (cm)	Polarization	Azimuth (deg)	Correct Factor (dB)
1279.125000	41.07	---	68.20	27.13	100.0	H	253.0	-6.8
1400.750000	---	30.81	54.00	23.19	100.0	V	139.0	-6.2
1599.375000	---	32.16	54.00	21.84	100.0	H	0.0	-5.0
1997.500000	55.39	---	68.20	12.81	200.0	H	22.0	-2.7
2644.125000	46.69	---	68.20	21.51	100.0	V	298.0	0.3
2755.250000	---	35.53	54.00	18.47	100.0	V	238.0	0.8
3022.125000	47.43	---	68.20	20.77	100.0	V	214.0	2.1
3478.875000	49.21	---	68.20	18.99	100.0	V	93.0	3.7
3984.625000	---	39.03	54.00	14.97	100.0	V	162.0	6.1
5000.500000	---	40.70	54.00	13.30	100.0	V	58.0	8.7
5994.500000	58.42	---	68.20	9.78	100.0	V	157.0	9.7
7565.125000	---	40.25	54.00	13.75	200.0	V	85.0	11.4

Remark: 1. Correction Factor = Antenna factor+ Insertion loss (cable loss + amplifier gain)

802.11n (HT40) CH159

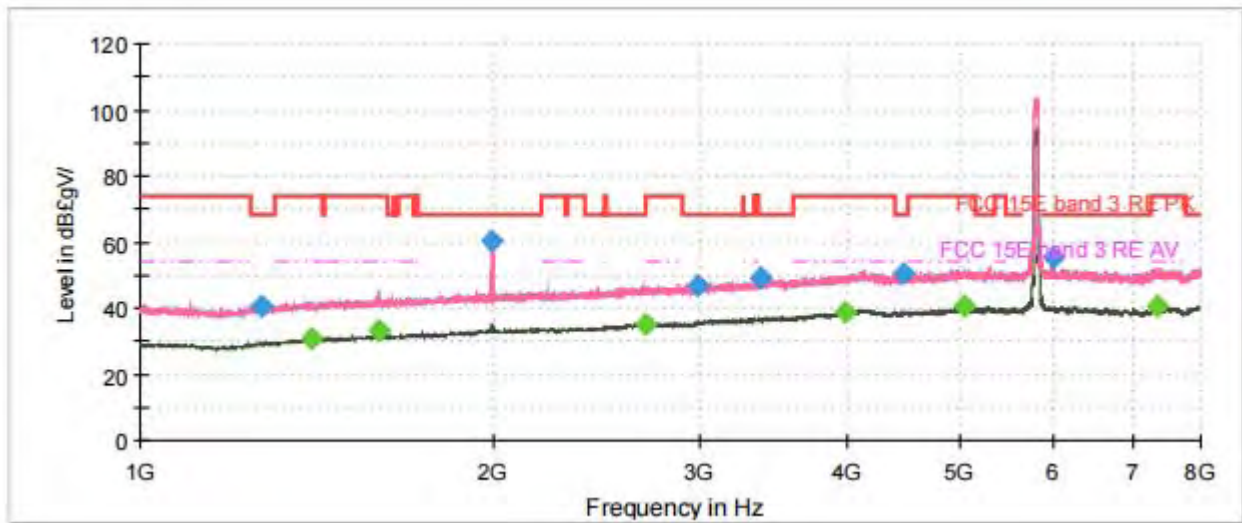

Note: The signal beyond the limit is carrier.
Radiates Emission from 1GHz to 8GHz

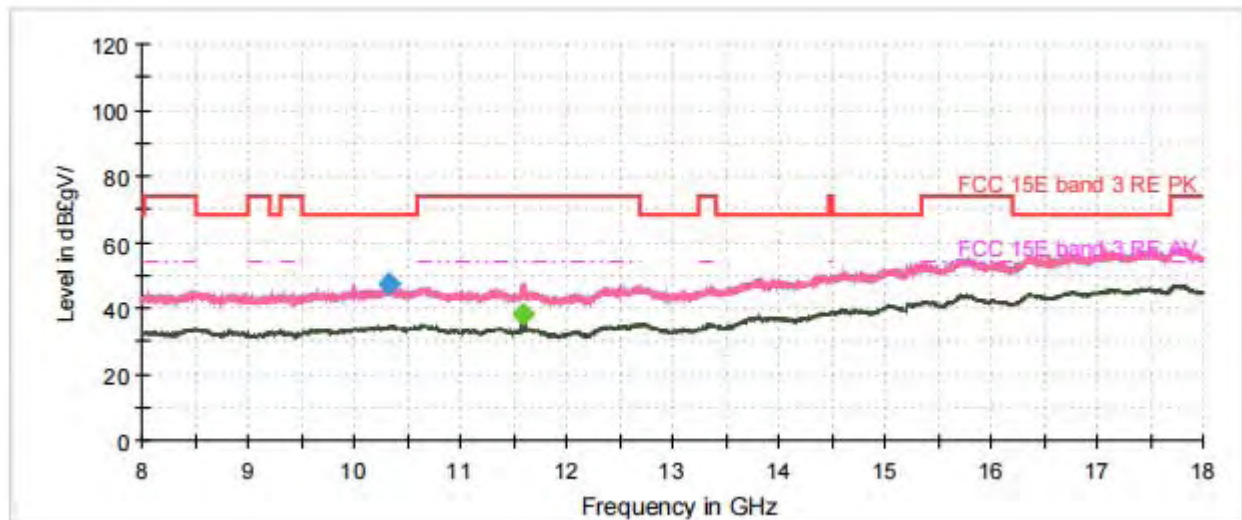

Radiates Emission from 8GHz to 18GHz



Frequency (MHz)	Peak (dBuV/m)	Average (dBuV/m)	Limit (dBuV/m)	Margin (dB)	Height (cm)	Polarization	Azimuth (deg)	Correct Factor (dB)
1270.375000	40.88	---	68.20	27.32	200.0	V	231.0	-6.9
1401.625000	---	30.98	54.00	23.02	100.0	V	332.0	-6.2
1596.750000	---	33.13	54.00	20.87	100.0	H	315.0	-5.1
1995.750000	60.08	---	68.20	8.12	100.0	V	284.0	-2.7
2691.375000	---	35.36	54.00	18.64	200.0	V	195.0	0.5
2978.375000	46.79	---	68.20	21.41	100.0	H	76.0	1.8
3368.625000	48.93	---	68.20	19.27	100.0	H	359.0	3.3
3988.125000	---	38.82	54.00	15.18	200.0	H	199.0	6.1
4468.500000	50.40	---	68.20	17.80	100.0	V	41.0	6.4
5024.125000	---	40.58	54.00	13.42	200.0	V	62.0	8.7
5990.125000	55.53	---	68.20	12.67	100.0	V	297.0	9.7
7339.375000	---	40.64	54.00	13.36	200.0	H	223.0	11.4

Remark: 1. Correction Factor = Antenna factor+ Insertion loss (cable loss + amplifier gain)

802.11ac (HT80) CH42

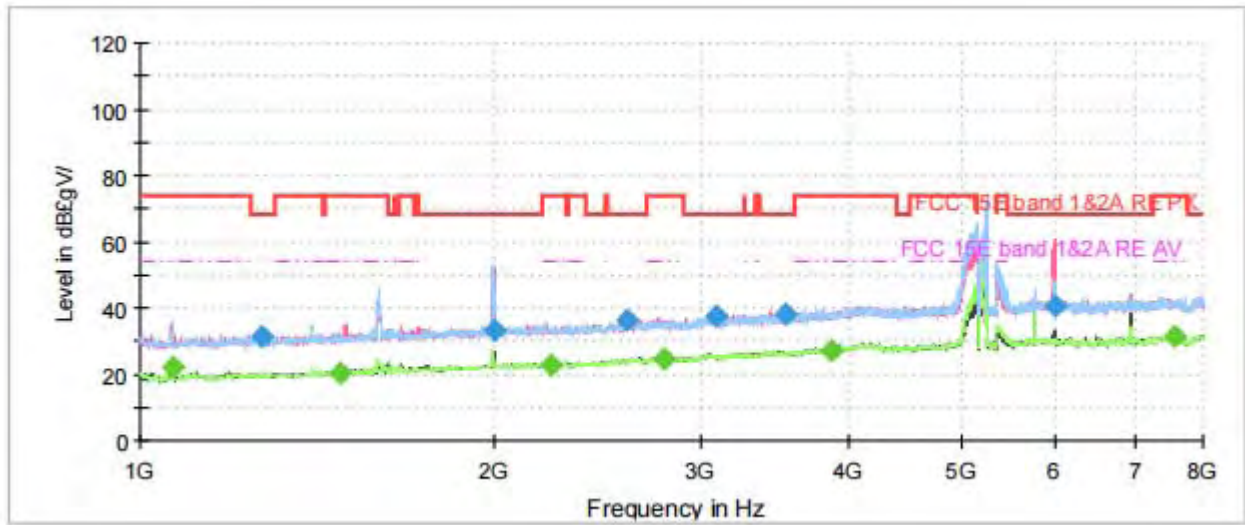

Note: The signal beyond the limit is carrier.
Radiates Emission from 1GHz to 8GHz

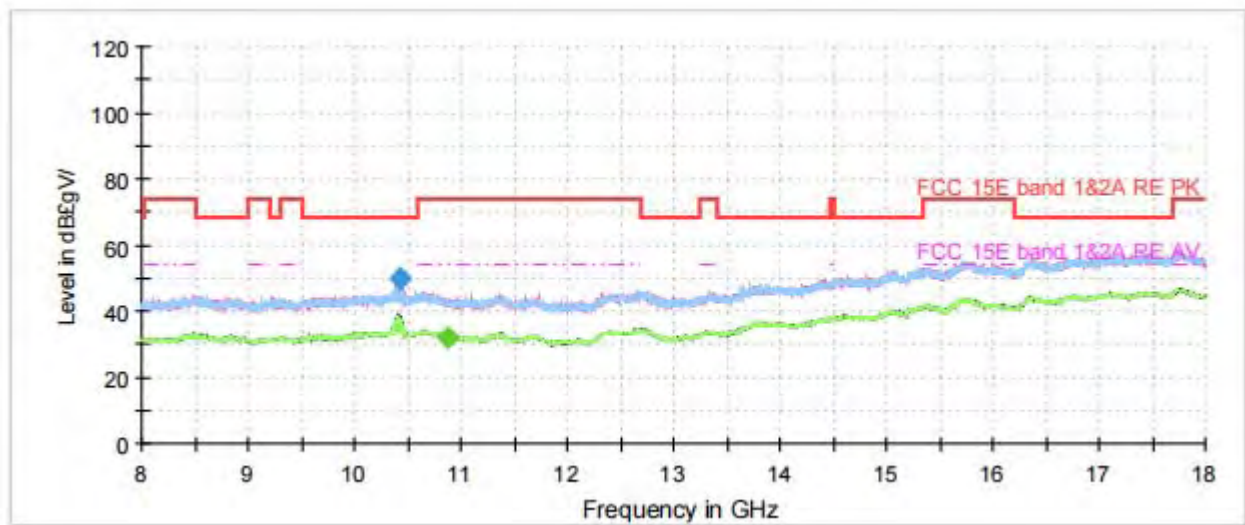

Radiates Emission from 8GHz to 18GHz



Frequency (MHz)	Peak (dBuV/m)	Average (dBuV/m)	Limit (dBuV/m)	Margin (dB)	Height (cm)	Polarization	Azimuth (deg)	Correct Factor (dB)
1064.750000	---	22.33	54.00	31.67	200.0	H	344.0	-18.0
1269.500000	31.09	---	68.20	37.11	100.0	H	0.0	-16.9
1477.750000	---	20.57	54.00	33.43	200.0	V	283.0	-15.7
1997.500000	33.52	---	68.20	34.68	100.0	V	295.0	-12.7
2229.375000	---	22.67	54.00	31.33	100.0	H	129.0	-11.7
2594.250000	36.33	---	68.20	31.87	100.0	V	104.0	-10.0
2791.125000	---	24.70	54.00	29.30	100.0	V	324.0	-9.1
3084.250000	37.55	---	68.20	30.65	100.0	H	30.0	-7.6
3540.125000	38.16	---	68.20	30.04	200.0	H	260.0	-6.2
3872.625000	---	27.33	54.00	26.67	100.0	V	245.0	-4.7
5988.375000	40.91	---	68.20	27.29	100.0	H	129.0	-0.3
7562.500000	---	31.11	54.00	22.89	200.0	V	154.0	1.4

Remark: 1. Correction Factor = Antenna factor+ Insertion loss (cable loss + amplifier gain)

802.11ac (HT80) CH58

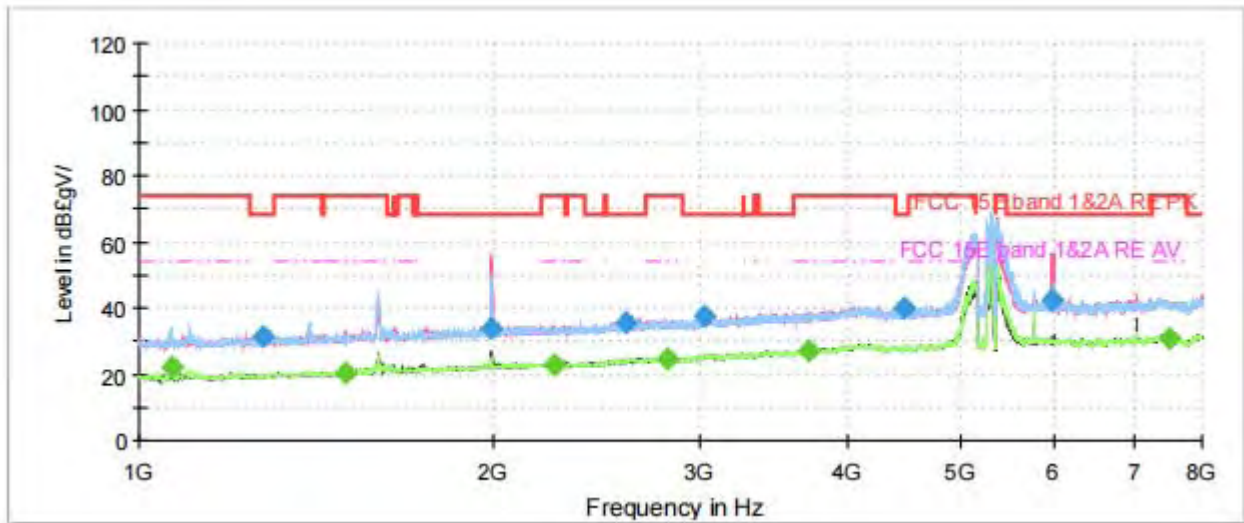

Note: The signal beyond the limit is carrier.
Radiates Emission from 1GHz to 8GHz

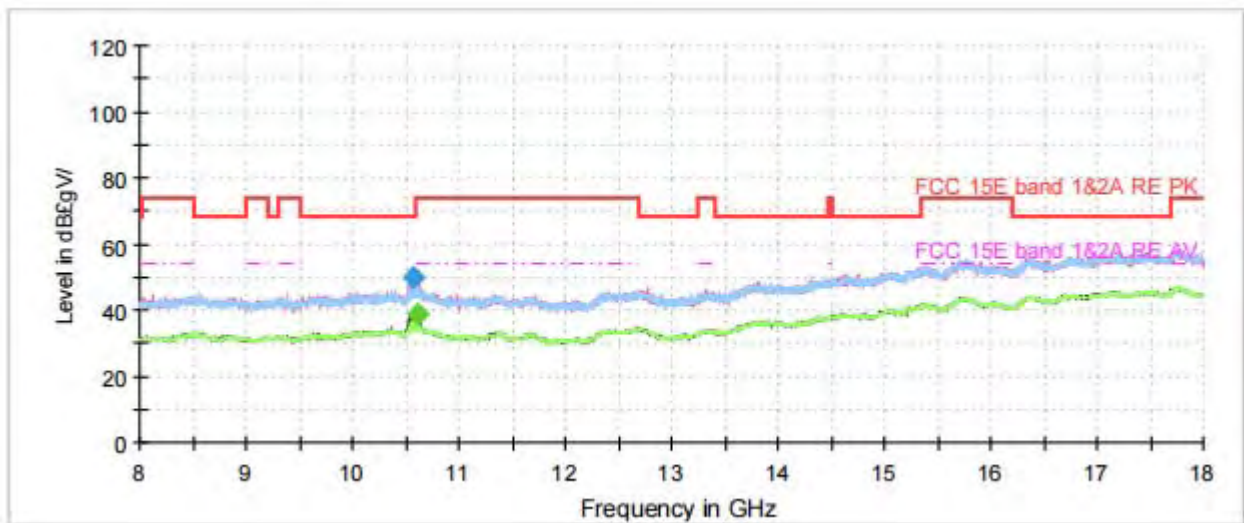

Radiates Emission from 8GHz to 18GHz



Frequency (MHz)	Peak (dBuV/m)	Average (dBuV/m)	Limit (dBuV/m)	Margin (dB)	Height (cm)	Polarization	Azimuth (deg)	Correct Factor (dB)
1064.750000	---	22.30	54.00	31.70	100.0	H	0.0	-18.0
1273.000000	31.19	---	68.20	37.01	100.0	V	123.0	-16.9
1500.500000	---	20.45	54.00	33.55	200.0	V	250.0	-15.6
1991.375000	33.85	---	68.20	34.35	100.0	V	334.0	-12.7
2255.625000	---	22.68	54.00	31.32	100.0	V	129.0	-11.6
2594.250000	35.62	---	68.20	32.58	200.0	H	183.0	-10.0
2812.125000	---	24.69	54.00	29.31	200.0	V	70.0	-9.0
3015.125000	37.26	---	68.20	30.94	100.0	V	147.0	-8.0
3702.875000	---	27.06	54.00	26.94	100.0	V	334.0	-5.5
4468.500000	40.10	---	68.20	28.10	100.0	H	218.0	-3.6
5977.875000	42.41	---	68.20	25.79	100.0	H	144.0	-0.3
7508.250000	---	31.07	54.00	22.93	100.0	V	322.0	1.5

Remark: 1. Correction Factor = Antenna factor+ Insertion loss (cable loss + amplifier gain)

802.11ac (HT80) CH106

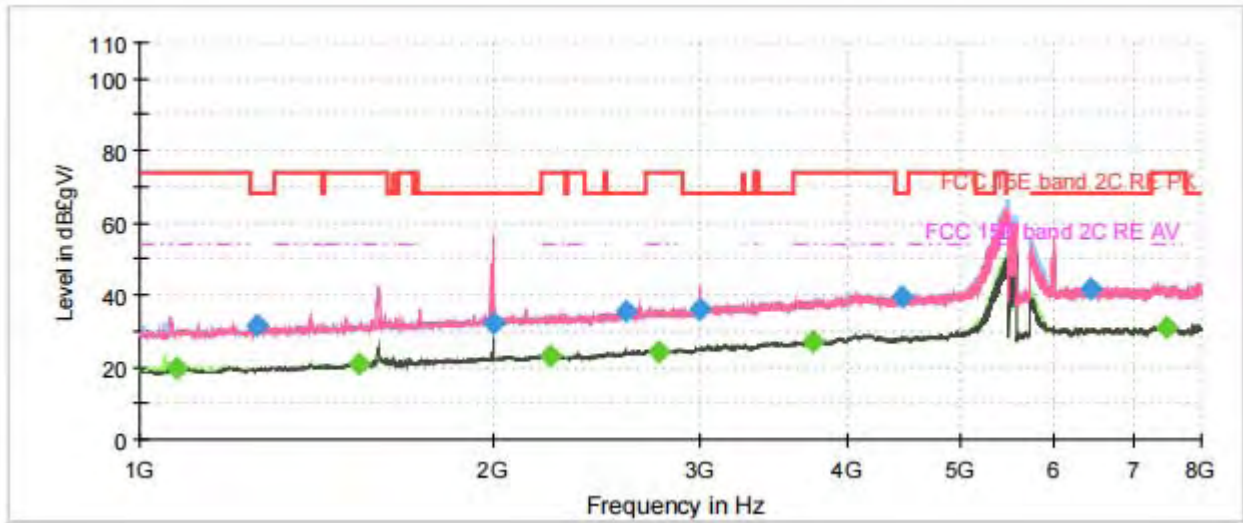

Note: The signal beyond the limit is carrier.
Radiates Emission from 1GHz to 8GHz

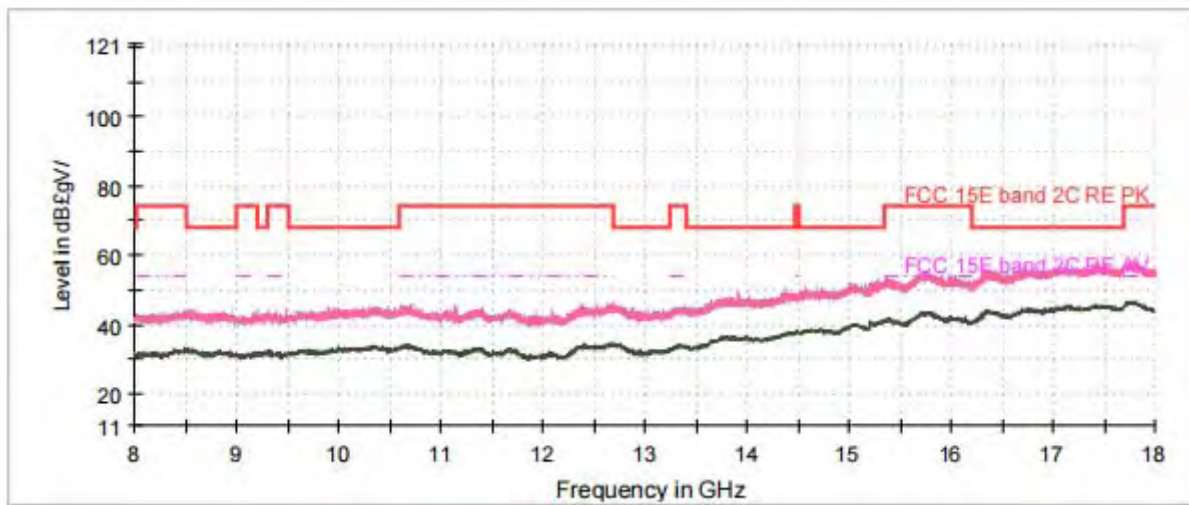

Radiates Emission from 8GHz to 18GHz



Frequency (MHz)	Peak (dBuV/m)	Average (dBuV/m)	Limit (dBuV/m)	Margin (dB)	Height (cm)	Polarization	Azimuth (deg)	Correct Factor (dB)
1076.125000	---	19.51	54.00	34.49	100.0	V	140.0	-17.9
1259.875000	31.77	---	68.20	36.43	100.0	V	62.0	-16.9
1534.625000	---	21.09	54.00	32.91	200.0	H	339.0	-15.4
1997.500000	32.29	---	68.20	35.91	100.0	V	193.0	-12.7
2238.125000	---	22.90	54.00	31.10	200.0	H	60.0	-11.7
2591.625000	35.30	---	68.20	32.90	200.0	H	0.0	-10.0
2758.750000	---	24.41	54.00	29.59	100.0	H	0.0	-9.2
2997.625000	36.34	---	68.20	31.86	100.0	V	253.0	-8.1
3738.750000	---	27.14	54.00	26.86	100.0	H	255.0	-5.3
4454.500000	39.31	---	68.20	28.89	200.0	H	114.0	-3.7
6439.875000	41.87	---	68.20	26.33	100.0	V	21.0	0.3
7466.250000	---	31.09	54.00	22.92	100.0	H	172.0	1.5

Remark: 1. Correction Factor = Antenna factor+ Insertion loss (cable loss + amplifier gain)



802.11ac (HT80) CH138

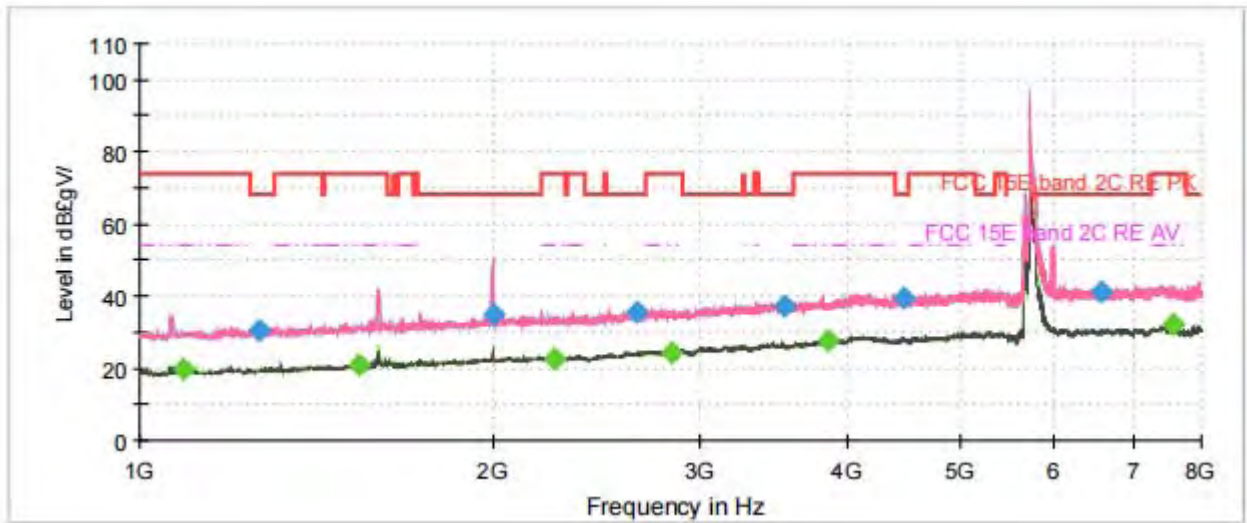

Note: The signal beyond the limit is carrier.
Radiates Emission from 1GHz to 8GHz

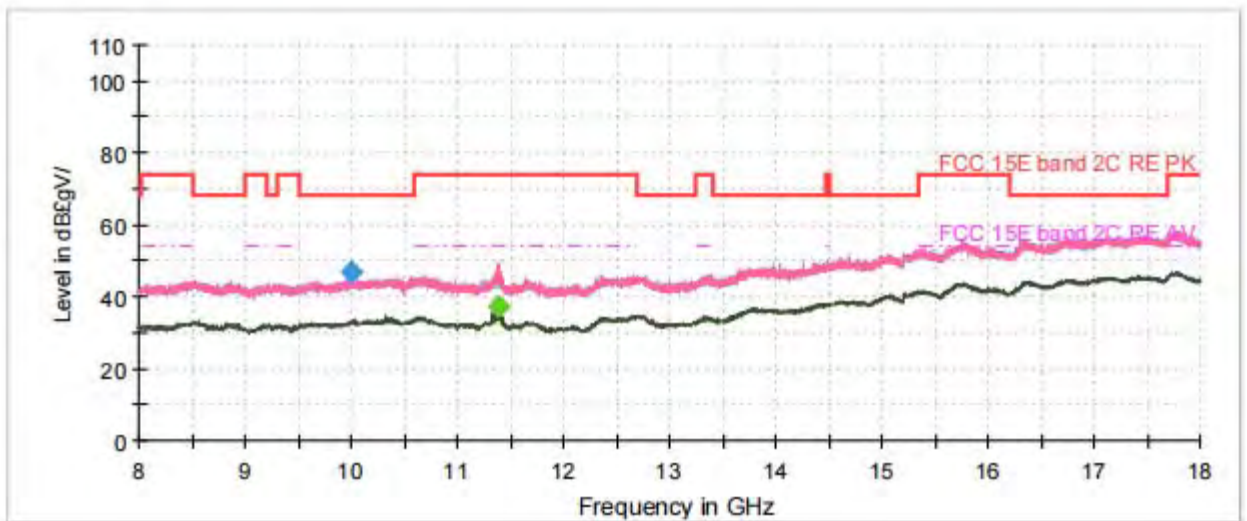

Radiates Emission from 8GHz to 18GHz



Frequency (MHz)	Peak (dBuV/m)	Average (dBuV/m)	Limit (dBuV/m)	Margin (dB)	Height (cm)	Polarization	Azimuth (deg)	Correct Factor (dB)
1086.625000	---	19.56	54.00	34.44	100.0	H	0.0	-17.9
1264.250000	30.39	---	68.20	37.81	200.0	H	242.0	-16.9
1538.125000	---	21.14	54.00	32.86	200.0	H	345.0	-15.4
1996.625000	34.95	---	68.20	33.25	200.0	H	358.0	-12.7
2253.000000	---	22.71	54.00	31.29	200.0	H	170.0	-11.6
2643.250000	35.65	---	68.20	32.55	200.0	V	305.0	-9.7
2829.625000	---	24.38	54.00	29.62	100.0	V	163.0	-9.0
3538.375000	37.05	---	68.20	31.15	200.0	H	52.0	-6.2
3844.625000	---	27.48	54.00	26.52	200.0	H	345.0	-4.8
4475.500000	39.28	---	68.20	28.92	200.0	V	0.0	-3.6
6591.250000	41.34	---	68.20	26.86	100.0	H	177.0	0.4
7565.125000	---	31.97	54.00	22.03	200.0	H	70.0	1.4

Remark: 1. Correction Factor = Antenna factor+ Insertion loss (cable loss + amplifier gain)

802.11ac (HT80) CH155

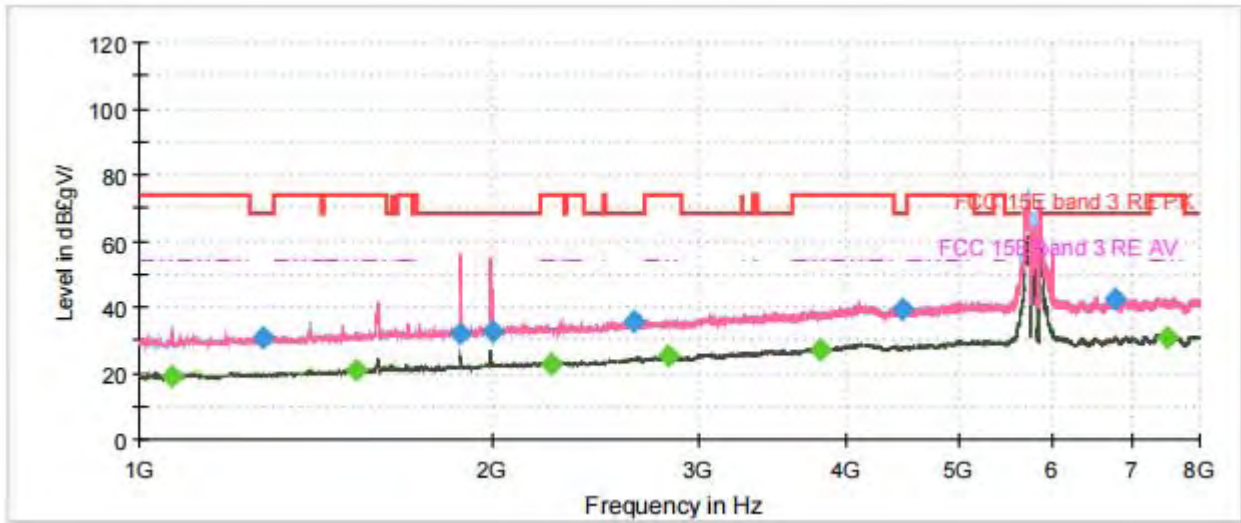

Note: The signal beyond the limit is carrier.
Radiates Emission from 1GHz to 8GHz

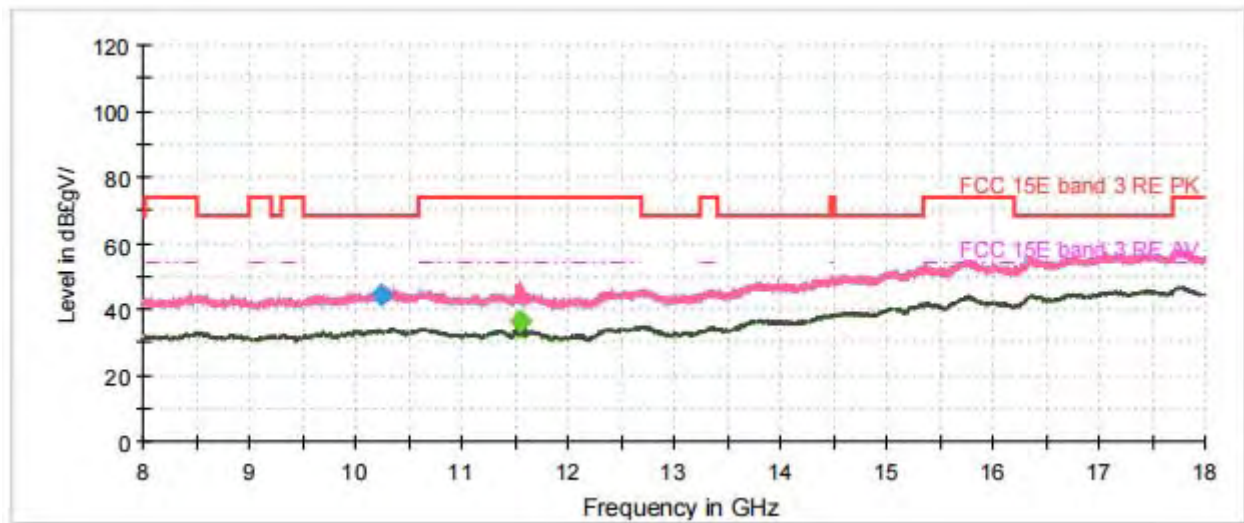

Radiates Emission from 8GHz to 18GHz



Frequency (MHz)	Peak (dBuV/m)	Average (dBuV/m)	Limit (dBuV/m)	Margin (dB)	Height (cm)	Polarization	Azimuth (deg)	Correct Factor (dB)
1063.875000	---	19.33	54.00	34.67	200.0	H	324.0	-18.0
1276.500000	30.76	---	68.20	37.44	100.0	H	245.0	-16.8
1531.125000	---	20.63	54.00	33.37	200.0	H	283.0	-15.4
1879.375000	32.16	---	68.20	36.04	200.0	V	223.0	-13.4
1997.500000	32.48	---	68.20	35.72	100.0	H	159.0	-12.7
2246.000000	---	22.75	54.00	31.25	200.0	V	229.0	-11.7
2638.000000	35.55	---	68.20	32.65	200.0	V	211.0	-9.7
2820.000000	---	24.93	54.00	29.07	100.0	H	171.0	-9.0
3806.125000	---	27.32	54.00	26.68	200.0	H	161.0	-5.0
4474.625000	39.45	---	68.20	28.75	200.0	H	11.0	-3.6
6787.250000	42.27	---	68.20	25.93	200.0	H	289.0	0.5
7496.000000	---	30.75	54.00	23.25	100.0	H	353.0	1.5

Remark: 1. Correction Factor = Antenna factor+ Insertion loss (cable loss + amplifier gain)

802.11ax (HE20) CH36

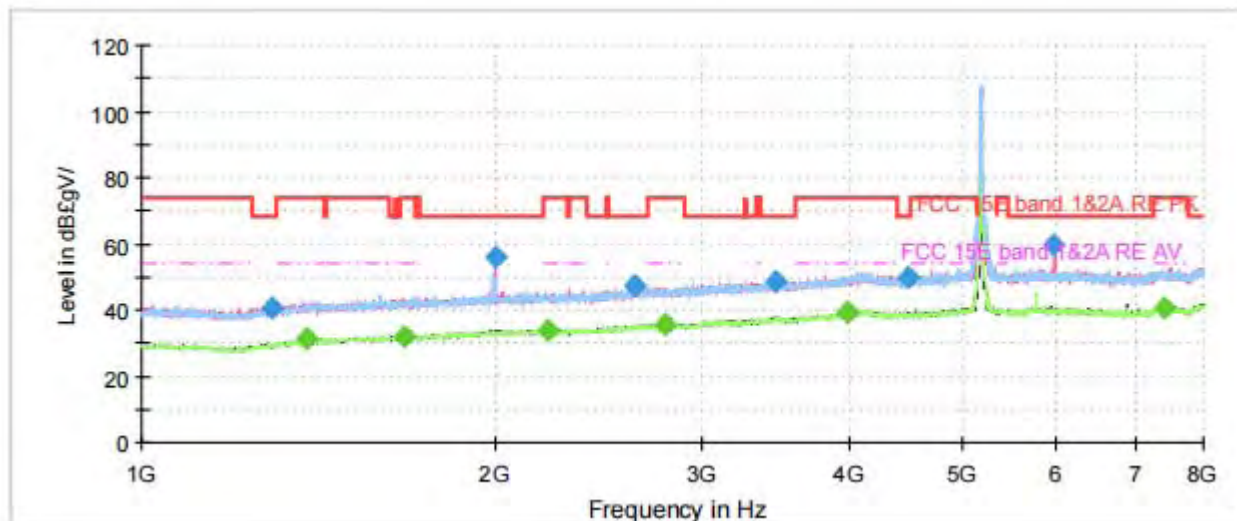

Note: The signal beyond the limit is carrier.
Radiates Emission from 1GHz to 8GHz

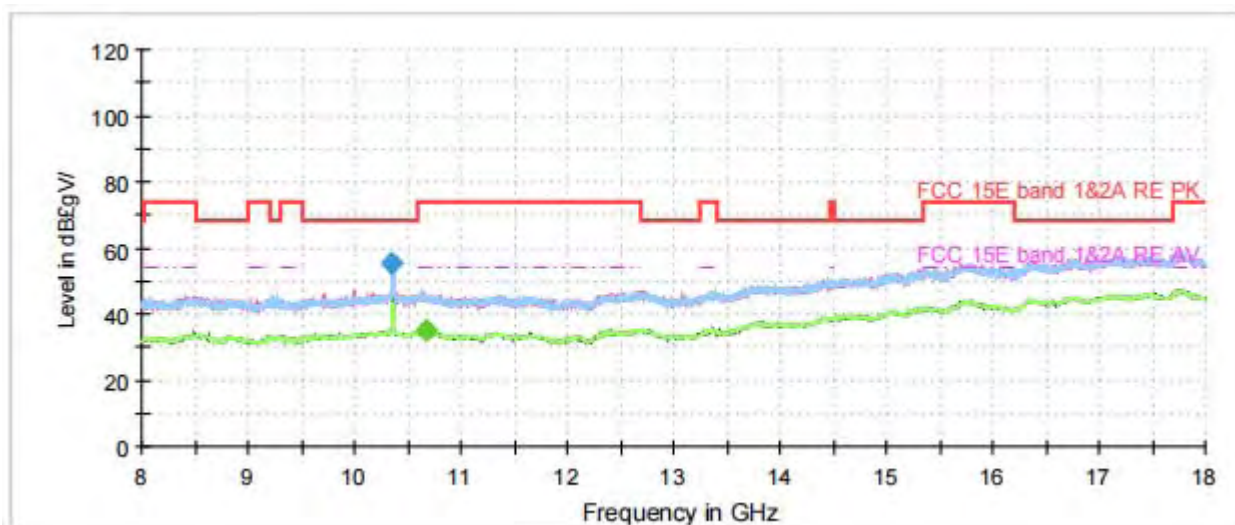

Radiates Emission from 8GHz to 18GHz



Frequency (MHz)	Peak (dBuV/m)	Average (dBuV/m)	Limit (dBuV/m)	Margin (dB)	Height (cm)	Polarization	Azimuth (deg)	Correct Factor (dB)
1293.125000	40.84	---	68.20	27.36	100.0	H	279.0	-6.8
1378.875000	---	31.09	54.00	22.91	100.0	V	136.0	-6.3
1672.875000	---	32.20	54.00	21.80	100.0	H	0.0	-4.6
1999.250000	56.14	---	68.20	12.06	100.0	V	302.0	-2.7
2212.750000	---	33.55	54.00	20.45	100.0	V	55.0	-1.7
2621.375000	47.27	---	68.20	20.93	100.0	H	320.0	0.2
2785.000000	---	35.53	54.00	18.47	100.0	H	62.0	0.9
3456.125000	48.79	---	68.20	19.41	100.0	H	80.0	3.6
3982.875000	---	39.12	54.00	14.88	100.0	H	28.0	6.0
4477.250000	49.65	---	68.20	18.55	100.0	H	0.0	6.4
5977.875000	59.76	---	68.20	8.44	100.0	V	331.0	9.7
7424.250000	---	40.83	54.00	13.17	100.0	V	0.0	11.5

Remark: 1. Correction Factor = Antenna factor+ Insertion loss (cable loss + amplifier gain)

802.11ax (HE20) CH40

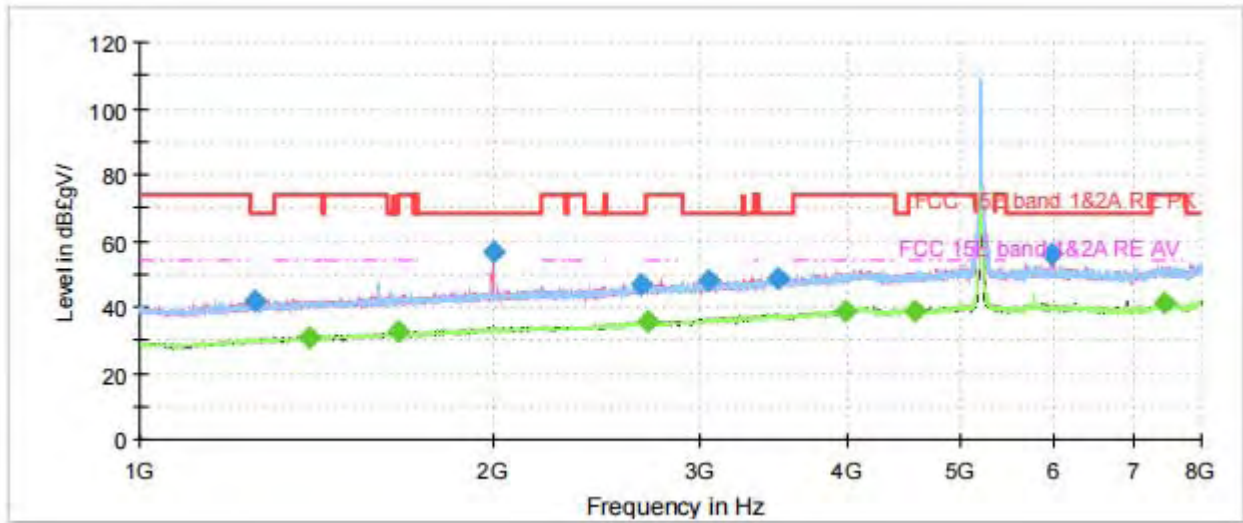

Note: The signal beyond the limit is carrier.
Radiates Emission from 1GHz to 8GHz

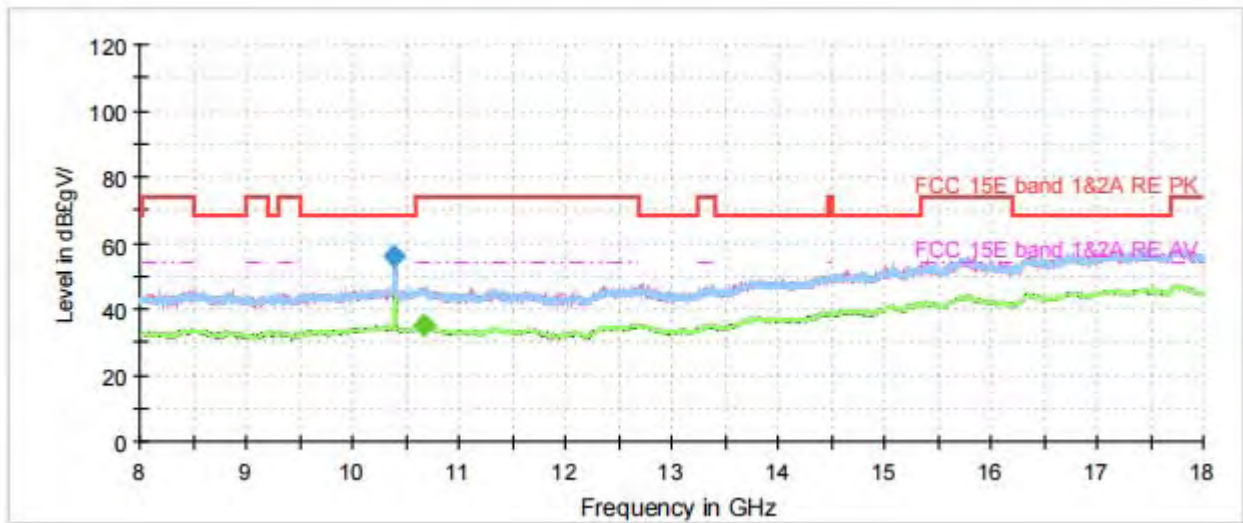

Radiates Emission from 8GHz to 18GHz



Frequency (MHz)	Peak (dBuV/m)	Average (dBuV/m)	Limit (dBuV/m)	Margin (dB)	Height (cm)	Polarization	Azimuth (deg)	Correct Factor (dB)
1254.625000	41.60	---	68.20	26.60	100.0	H	229.0	-7.0
1392.875000	---	31.06	54.00	22.94	100.0	V	181.0	-6.2
1661.500000	---	32.31	54.00	21.69	100.0	H	229.0	-4.7
1999.250000	56.73	---	68.20	11.47	100.0	V	277.0	-2.7
2670.375000	46.64	---	68.20	21.56	100.0	H	336.0	0.4
2709.750000	---	35.58	54.00	18.42	100.0	H	285.0	0.6
3044.000000	48.29	---	68.20	19.91	100.0	H	250.0	2.2
3493.750000	48.87	---	68.20	19.33	100.0	V	181.0	3.7
3986.375000	---	39.00	54.00	15.00	100.0	H	325.0	6.1
4556.875000	---	38.97	54.00	15.03	100.0	V	181.0	6.7
5970.875000	55.98	---	68.20	12.22	100.0	V	0.0	9.7
7456.625000	---	41.01	54.00	12.99	100.0	V	139.0	11.5

Remark: 1. Correction Factor = Antenna factor+ Insertion loss (cable loss + amplifier gain)

802.11ax (HE20) CH48

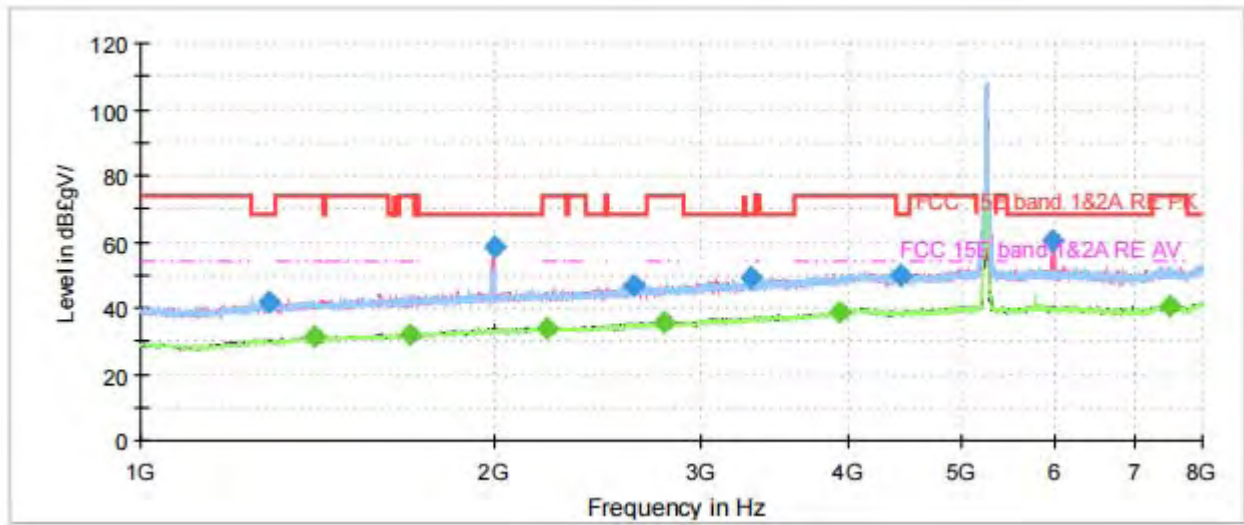

Note: The signal beyond the limit is carrier.
Radiates Emission from 1GHz to 8GHz

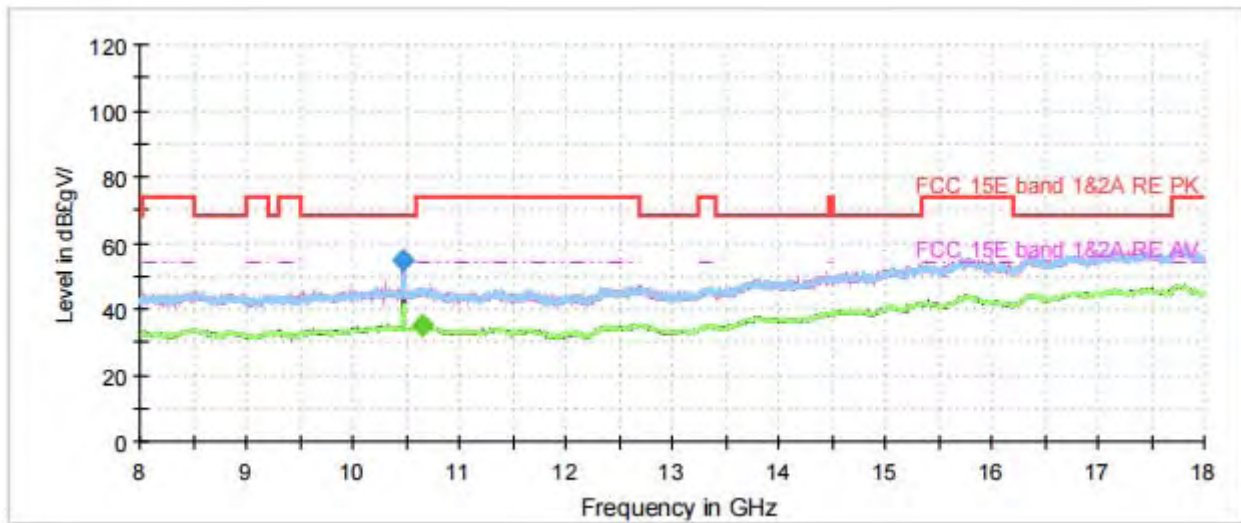

Radiates Emission from 8GHz to 18GHz



Frequency (MHz)	Peak (dBuV/m)	Average (dBuV/m)	Limit (dBuV/m)	Margin (dB)	Height (cm)	Polarization	Azimuth (deg)	Correct Factor (dB)
1283.500000	41.55	---	68.20	26.65	100.0	V	49.0	-6.8
1404.250000	---	31.38	54.00	22.62	100.0	V	326.0	-6.1
1696.500000	---	32.17	54.00	21.83	100.0	H	351.0	-4.5
1997.500000	58.26	---	68.20	9.94	100.0	V	297.0	-2.7
2211.875000	---	33.87	54.00	20.13	100.0	V	9.0	-1.7
2621.375000	46.61	---	68.20	21.59	100.0	V	9.0	0.2
2781.500000	---	35.69	54.00	18.31	100.0	V	55.0	0.9
3304.750000	49.20	---	68.20	19.00	100.0	V	160.0	3.0
3940.875000	---	38.93	54.00	15.07	100.0	H	297.0	5.7
4422.125000	50.11	---	68.20	18.09	100.0	H	356.0	6.3
5971.750000	60.06	---	68.20	8.14	100.0	V	336.0	9.7
7511.750000	---	40.69	54.00	13.31	100.0	H	126.0	11.5

Remark: 1. Correction Factor = Antenna factor+ Insertion loss (cable loss + amplifier gain)

802.11ax (HE20) CH52

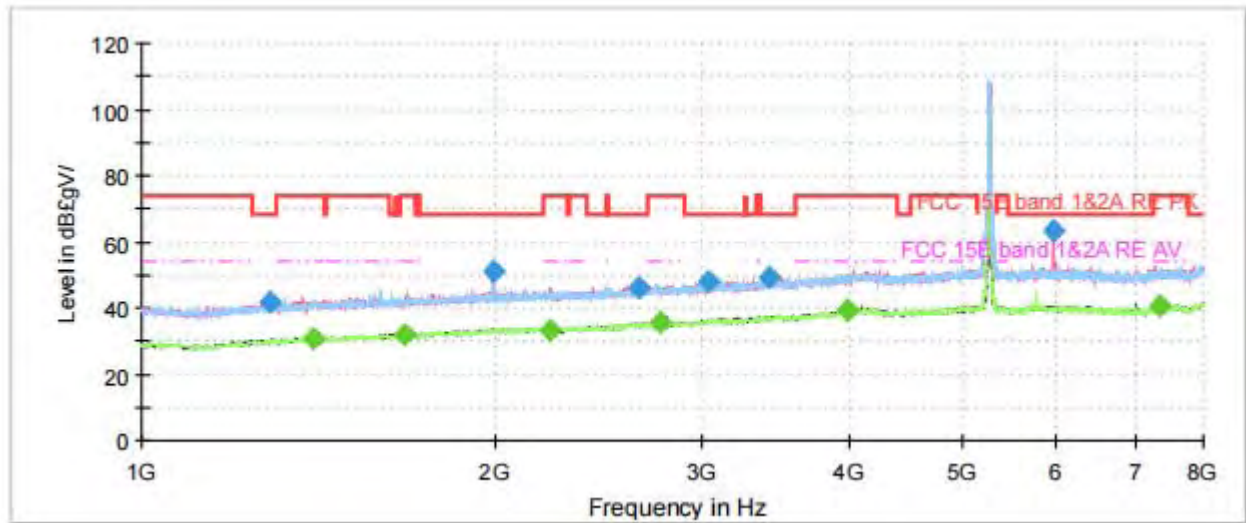

Note: The signal beyond the limit is carrier.
Radiates Emission from 1GHz to 8GHz

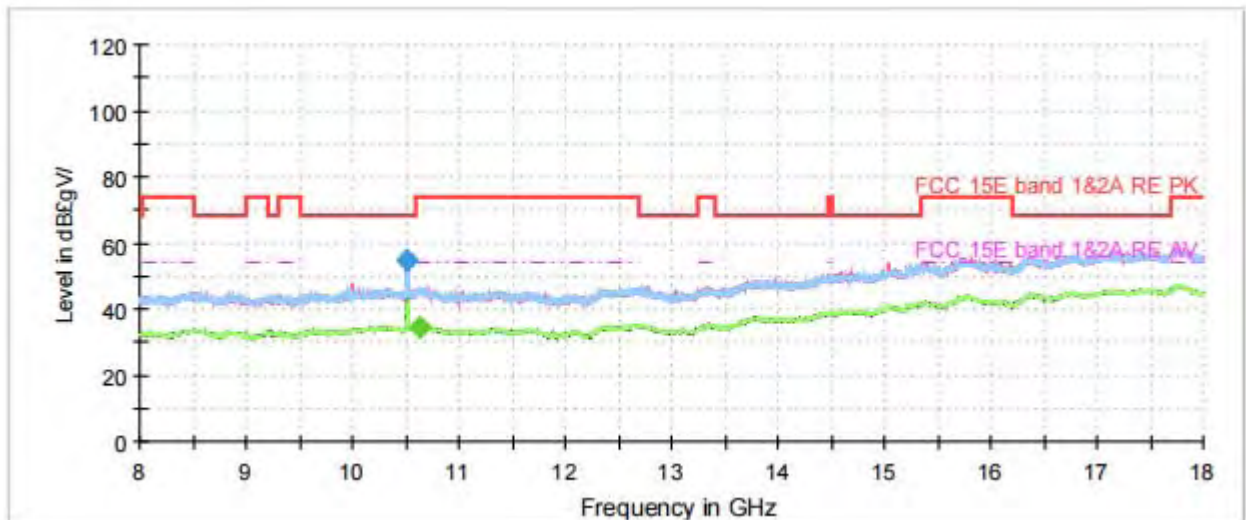

Radiates Emission from 8GHz to 18GHz



Frequency (MHz)	Peak (dBuV/m)	Average (dBuV/m)	Limit (dBuV/m)	Margin (dB)	Height (cm)	Polarization	Azimuth (deg)	Correct Factor (dB)
1283.500000	41.56	---	68.20	26.64	100.0	V	25.0	-6.8
1396.375000	---	30.94	54.00	23.06	100.0	V	270.0	-6.2
1672.000000	---	32.18	54.00	21.82	100.0	V	31.0	-4.6
1992.250000	51.32	---	68.20	16.88	100.0	V	234.0	-2.7
2225.000000	---	33.54	54.00	20.46	100.0	H	175.0	-1.7
2643.250000	46.28	---	68.20	21.92	100.0	V	25.0	0.3
2768.375000	---	35.72	54.00	18.28	100.0	H	229.0	0.8
3037.000000	47.90	---	68.20	20.30	100.0	H	252.0	2.2
3420.250000	49.05	---	68.20	19.15	100.0	V	327.0	3.5
3988.125000	---	39.28	54.00	14.72	100.0	H	349.0	6.1
5977.000000	63.26	---	68.20	4.94	100.0	V	340.0	9.7
7339.375000	---	40.83	54.00	13.17	100.0	H	68.0	11.4

Remark: 1. Correction Factor = Antenna factor+ Insertion loss (cable loss + amplifier gain)

802.11ax (HE20) CH60

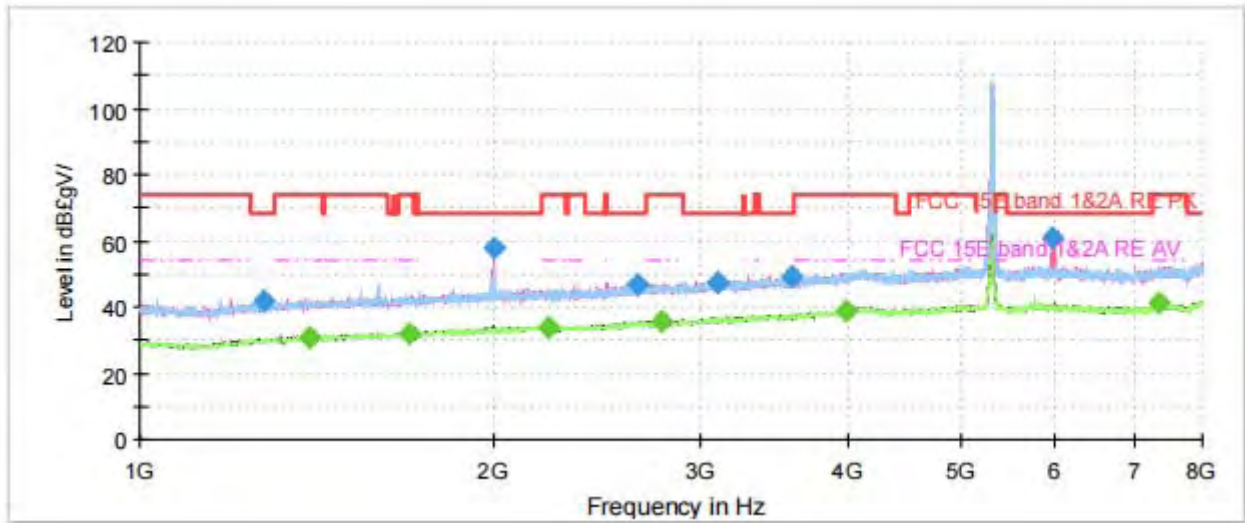

Note: The signal beyond the limit is carrier.
Radiates Emission from 1GHz to 8GHz

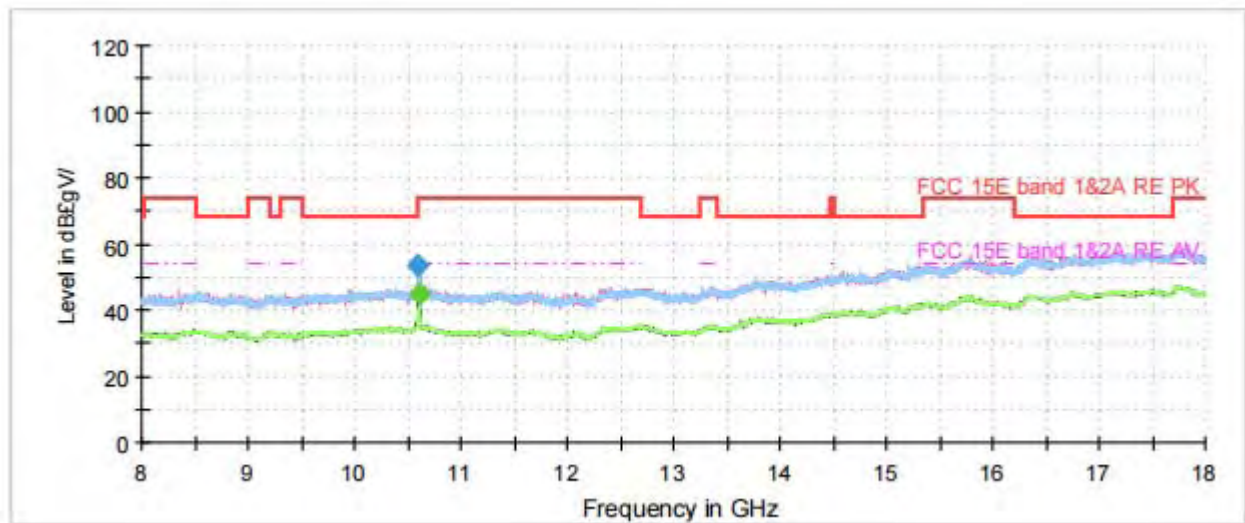

Radiates Emission from 8GHz to 18GHz



Frequency (MHz)	Peak (dBuV/m)	Average (dBuV/m)	Limit (dBuV/m)	Margin (dB)	Height (cm)	Polarization	Azimuth (deg)	Correct Factor (dB)
1273.875000	41.67	---	68.20	26.53	100.0	H	129.0	-6.9
1392.875000	---	30.94	54.00	23.06	100.0	V	50.0	-6.2
1694.750000	---	32.23	54.00	21.77	100.0	H	118.0	-4.5
1999.250000	57.60	---	68.20	10.60	100.0	V	284.0	-2.7
2228.500000	---	33.56	54.00	20.44	100.0	H	4.0	-1.7
2644.125000	46.58	---	68.20	21.62	100.0	V	25.0	0.3
2775.375000	---	35.72	54.00	18.28	100.0	V	0.0	0.9
3099.125000	47.44	---	68.20	20.76	100.0	V	85.0	2.5
3581.250000	49.04	---	68.20	19.16	100.0	H	225.0	4.0
3988.125000	---	38.86	54.00	15.14	100.0	V	253.0	6.1
5972.625000	61.07	---	68.20	7.13	100.0	V	343.0	9.7
7349.875000	---	40.94	54.00	13.06	100.0	V	108.0	11.5

Remark: 1. Correction Factor = Antenna factor+ Insertion loss (cable loss + amplifier gain)

802.11ax (HE20) CH64

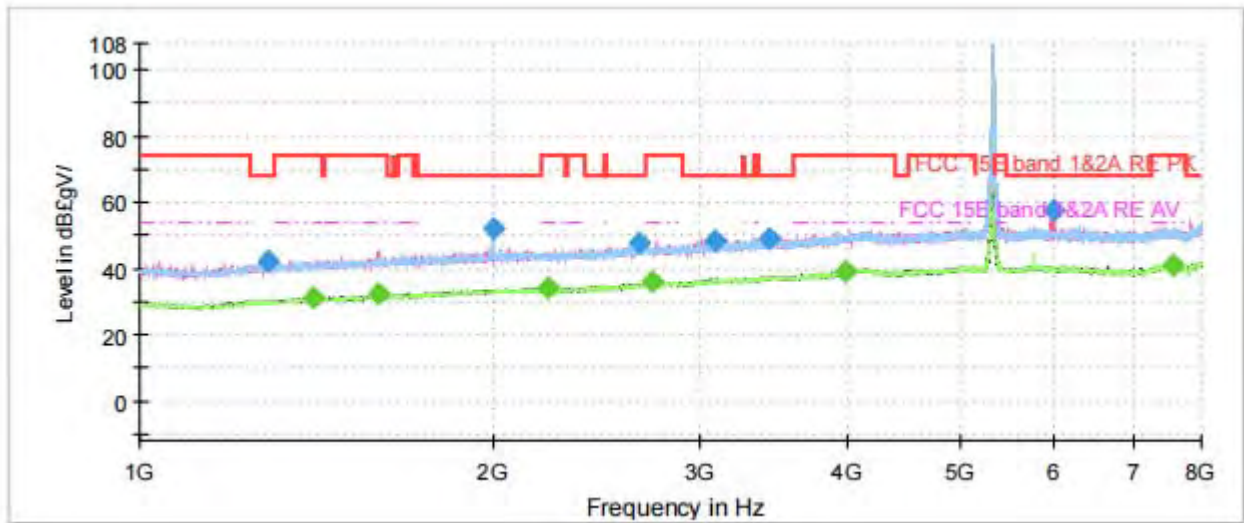

Note: The signal beyond the limit is carrier.
Radiates Emission from 1GHz to 8GHz

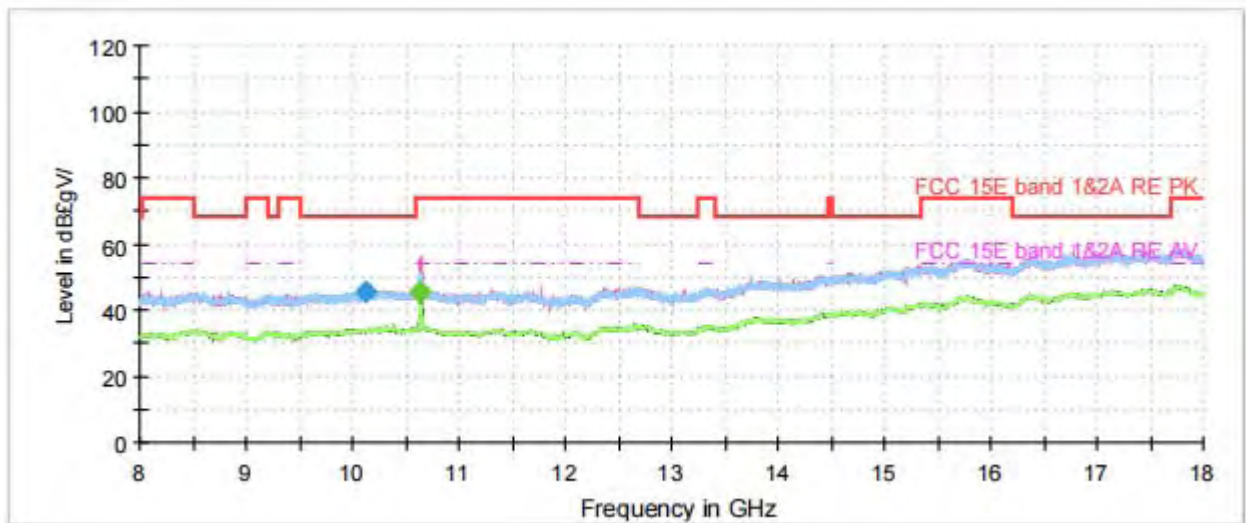

Radiates Emission from 8GHz to 18GHz



Frequency (MHz)	Peak (dBuV/m)	Average (dBuV/m)	Limit (dBuV/m)	Margin (dB)	Height (cm)	Polarization	Azimuth (deg)	Correct Factor (dB)
1286.125000	41.92	---	68.20	26.28	100.0	H	0.0	-6.8
1404.250000	---	30.96	54.00	23.04	100.0	H	356.0	-6.1
1594.125000	---	32.35	54.00	21.65	100.0	V	244.0	-5.1
1996.625000	52.06	---	68.20	16.14	100.0	H	80.0	-2.7
2222.375000	---	34.08	54.00	19.92	100.0	H	200.0	-1.7
2659.000000	47.51	---	68.20	20.69	100.0	V	179.0	0.4
2732.500000	---	35.79	54.00	18.21	100.0	H	344.0	0.7
3086.875000	48.13	---	68.20	20.07	100.0	V	105.0	2.4
3438.625000	48.98	---	68.20	19.22	100.0	V	67.0	3.5
3986.375000	---	39.09	54.00	14.91	100.0	H	63.0	6.1
5991.875000	57.81	---	68.20	10.39	100.0	V	250.0	9.7
7584.375000	---	40.85	54.00	13.15	100.0	V	268.0	11.4

Remark: 1. Correction Factor = Antenna factor+ Insertion loss (cable loss + amplifier gain)

802.11ax (HE20) CH100

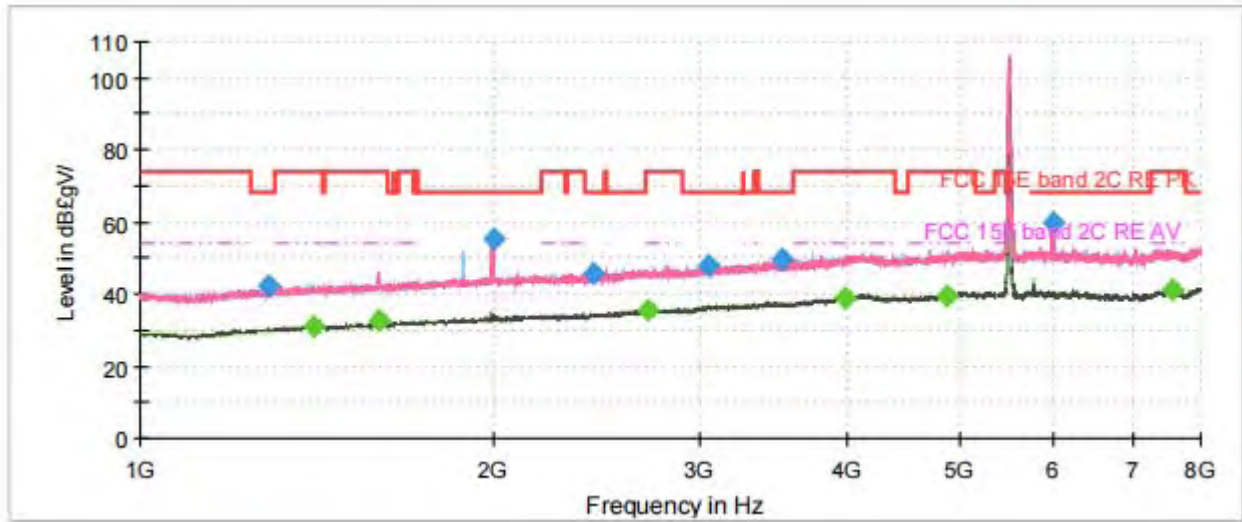

Note: The signal beyond the limit is carrier.
Radiates Emission from 1GHz to 8GHz

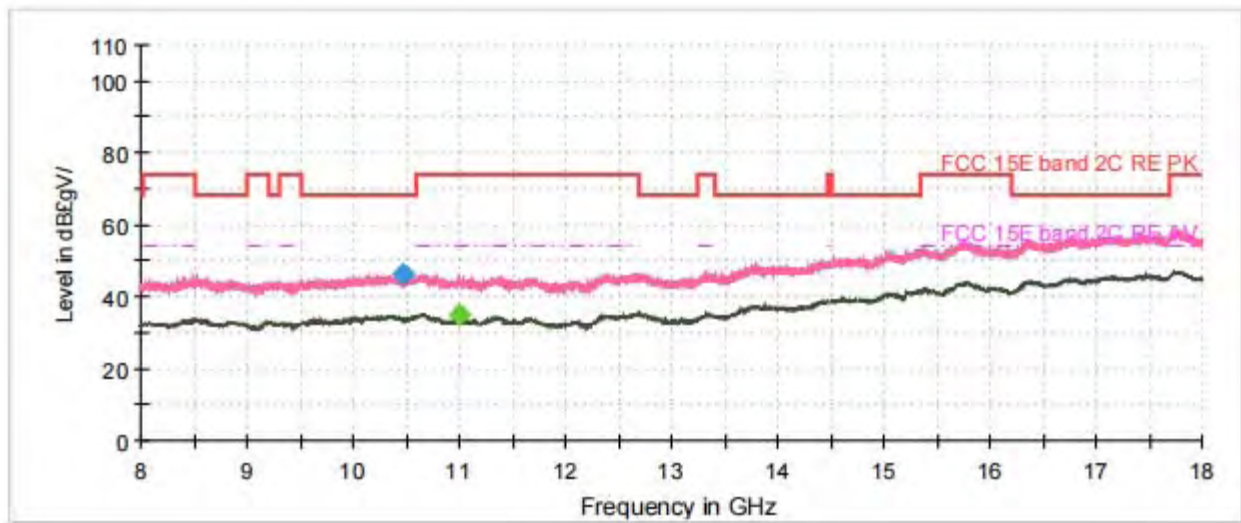

Radiates Emission from 8GHz to 18GHz



Frequency (MHz)	Peak (dBuV/m)	Average (dBuV/m)	Limit (dBuV/m)	Margin (dB)	Height (cm)	Polarization	Azimuth (deg)	Correct Factor (dB)
1282.625000	42.47	---	68.20	25.73	200.0	V	38.0	-6.8
1402.500000	---	31.24	54.00	22.76	200.0	V	1.0	-6.1
1593.250000	---	32.76	54.00	21.24	200.0	V	285.0	-5.1
1997.500000	55.44	---	68.20	12.76	100.0	V	352.0	-2.7
2430.625000	45.53	---	68.20	22.67	100.0	H	143.0	-1.0
2705.375000	---	35.59	54.00	18.41	200.0	V	55.0	0.6
3052.750000	47.86	---	68.20	20.34	200.0	H	229.0	2.3
3517.375000	49.41	---	68.20	18.79	200.0	H	247.0	3.8
3985.500000	---	39.09	54.00	14.91	100.0	H	161.0	6.1
4866.625000	---	39.69	54.00	14.31	200.0	H	229.0	7.9
5979.625000	60.03	---	68.20	8.17	100.0	V	340.0	9.7
7570.375000	---	40.91	54.00	13.09	100.0	H	0.0	11.4

Remark: 1. Correction Factor = Antenna factor+ Insertion loss (cable loss + amplifier gain)

802.11ax (HE20) CH116

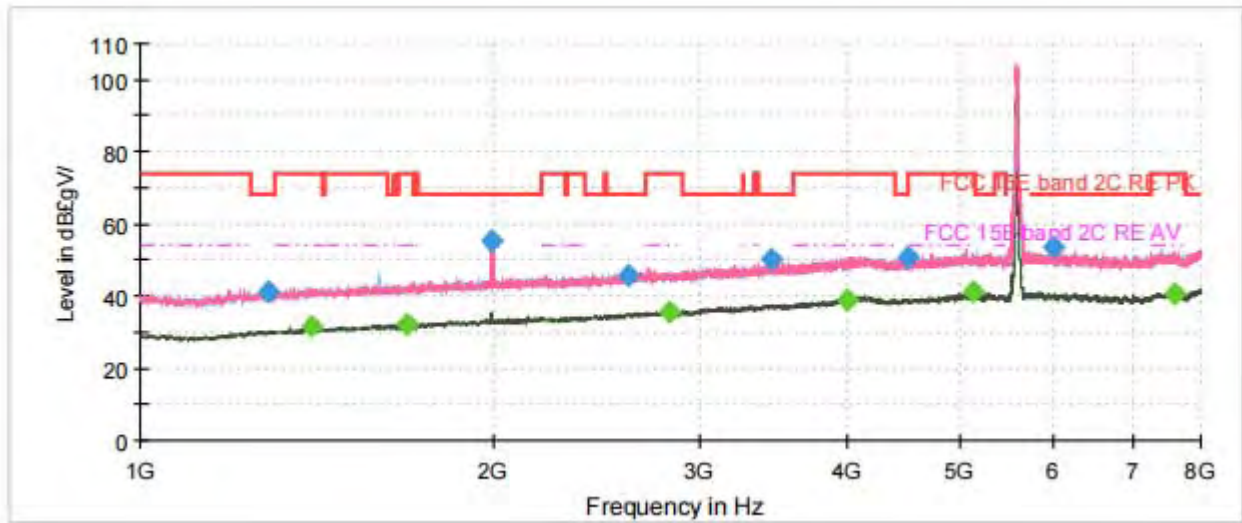

Note: The signal beyond the limit is carrier.
Radiates Emission from 1GHz to 8GHz

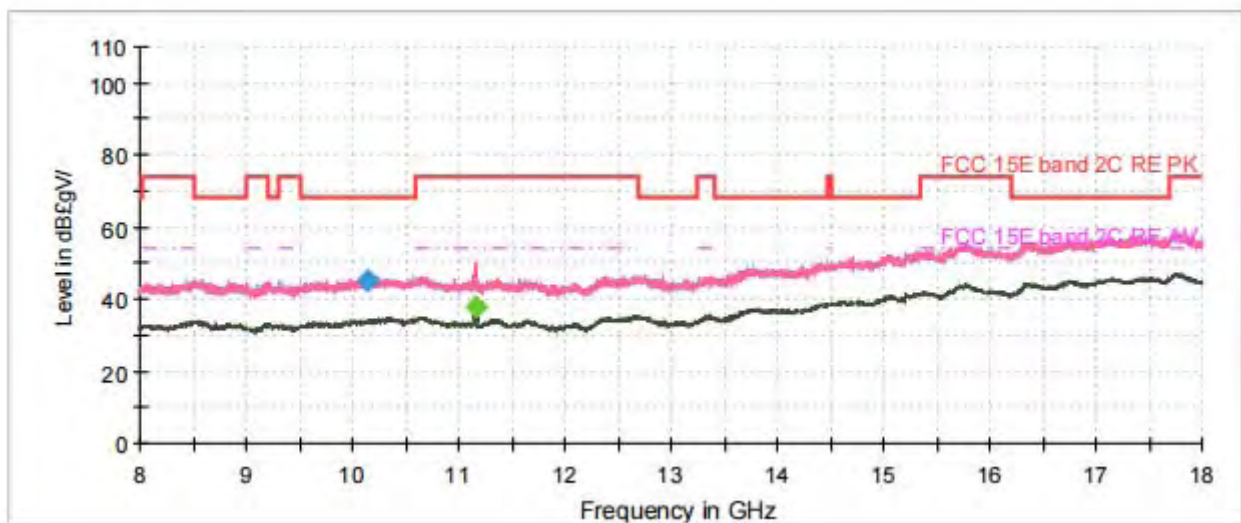

Radiates Emission from 8GHz to 18GHz



Frequency (MHz)	Peak (dBuV/m)	Average (dBuV/m)	Limit (dBuV/m)	Margin (dB)	Height (cm)	Polarization	Azimuth (deg)	Correct Factor (dB)
1286.125000	41.44	---	68.20	26.76	200.0	H	230.0	-6.8
1399.000000	---	31.32	54.00	22.68	200.0	H	298.0	-6.2
1689.500000	---	32.18	54.00	21.82	100.0	V	228.0	-4.5
1992.250000	55.40	---	68.20	12.80	200.0	V	284.0	-2.7
2600.375000	45.93	---	68.20	22.27	100.0	H	277.0	0.0
2823.500000	---	35.72	54.00	18.28	200.0	H	261.0	1.0
3448.250000	49.94	---	68.20	18.26	100.0	H	230.0	3.6
3994.250000	---	39.08	54.00	14.92	200.0	V	348.0	6.1
4512.250000	50.81	---	74.00	23.19	100.0	V	332.0	6.5
5118.625000	---	40.94	54.00	13.06	200.0	H	305.0	8.7
5998.875000	53.46	---	68.20	14.74	100.0	V	112.0	9.7
7613.250000	---	40.85	54.00	13.15	200.0	H	205.0	11.4

Remark: 1. Correction Factor = Antenna factor+ Insertion loss (cable loss + amplifier gain)

802.11ax (HE20) CH140

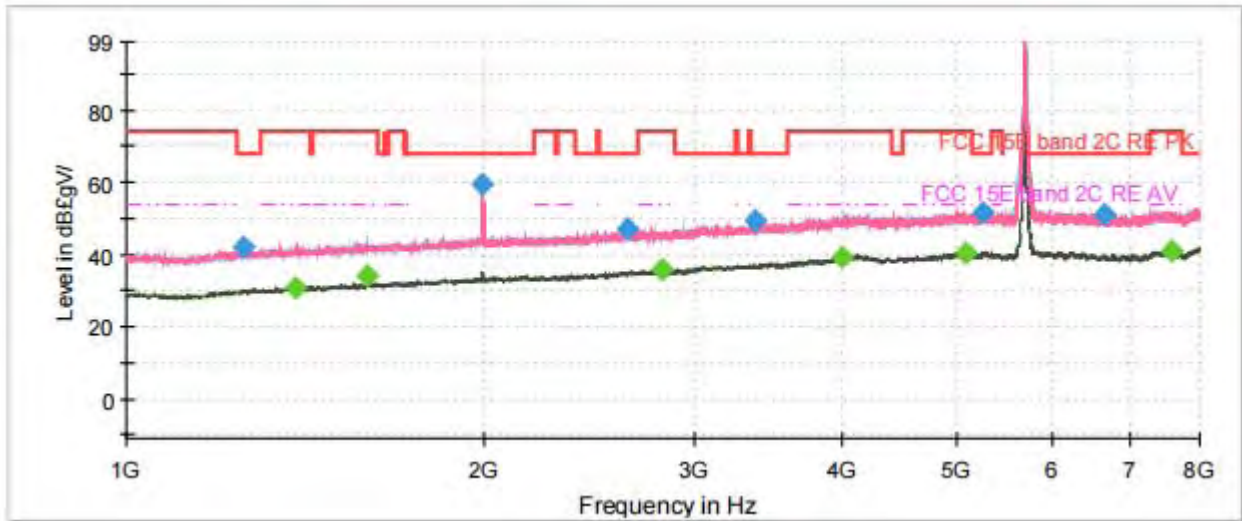

Note: The signal beyond the limit is carrier.
Radiates Emission from 1GHz to 8GHz

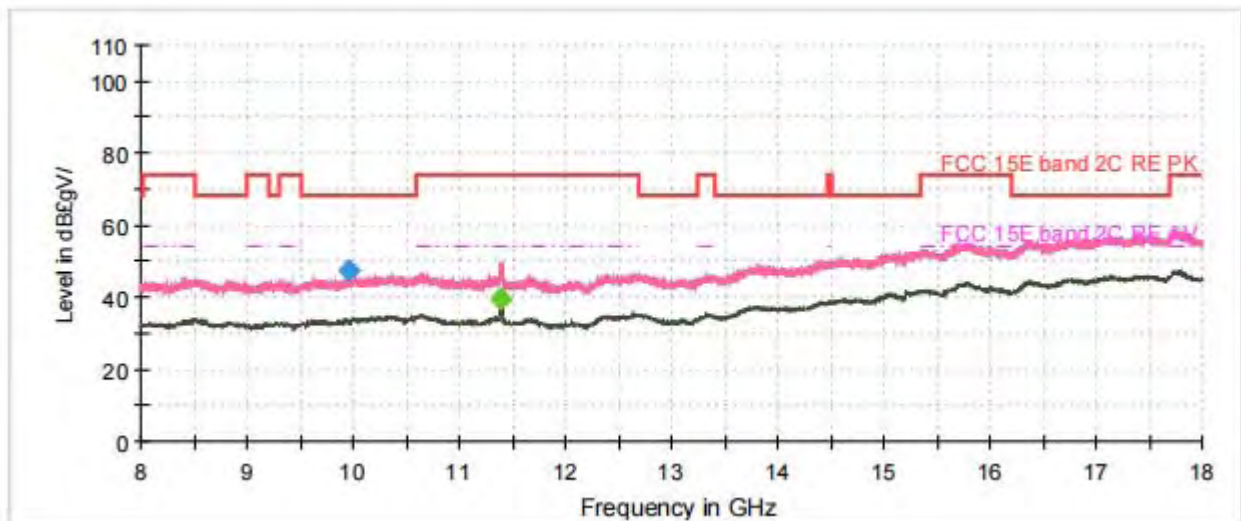

Radiates Emission from 8GHz to 18GHz



Frequency (MHz)	Peak (dBuV/m)	Average (dBuV/m)	Limit (dBuV/m)	Margin (dB)	Height (cm)	Polarization	Azimuth (deg)	Correct Factor (dB)
1254.625000	41.99	---	68.20	26.21	200.0	V	302.0	-7.0
1385.875000	---	30.86	54.00	23.14	100.0	V	294.0	-6.3
1593.250000	---	33.94	54.00	20.06	200.0	H	0.0	-5.1
1993.125000	59.38	---	68.20	8.82	100.0	V	294.0	-2.7
2638.000000	47.22	---	68.20	20.98	200.0	V	0.0	0.3
2825.250000	---	35.86	54.00	18.14	100.0	H	326.0	1.0
3380.000000	49.36	---	68.20	18.84	200.0	V	39.0	3.4
3993.375000	---	39.30	54.00	14.70	200.0	H	103.0	6.1
5086.250000	---	40.57	54.00	13.43	200.0	V	277.0	8.7
5263.000000	51.48	---	68.20	16.72	100.0	V	205.0	8.8
6647.250000	50.91	---	68.20	17.29	200.0	V	331.0	10.4
7586.125000	---	41.05	54.00	12.95	200.0	V	164.0	11.4

Remark: 1. Correction Factor = Antenna factor+ Insertion loss (cable loss + amplifier gain)



802.11ax (HE20) CH149

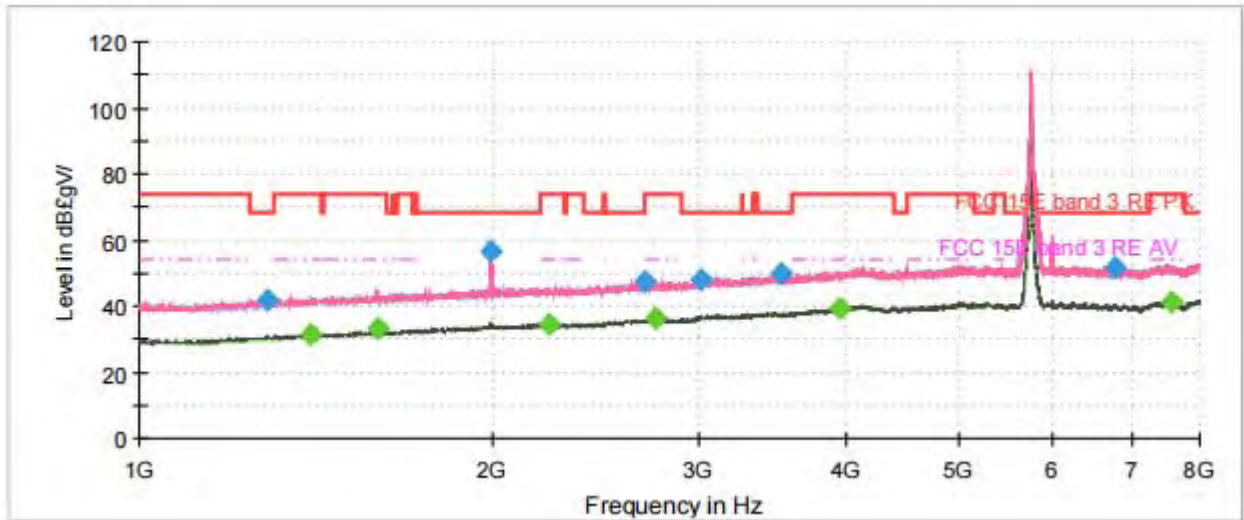

Note: The signal beyond the limit is carrier.
Radiates Emission from 1GHz to 8GHz

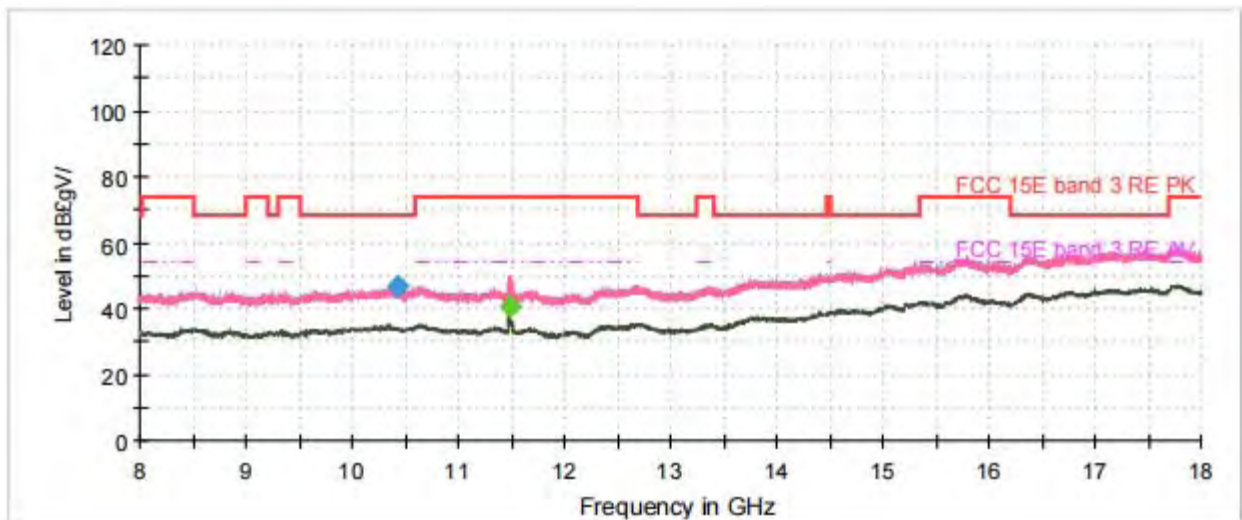

Radiates Emission from 8GHz to 18GHz



Frequency (MHz)	Peak (dBuV/m)	Average (dBuV/m)	Limit (dBuV/m)	Margin (dB)	Height (cm)	Polarization	Azimuth (deg)	Correct Factor (dB)
1286.125000	41.92	---	68.20	26.28	100.0	V	187.0	-6.8
1399.000000	---	31.35	54.00	22.65	200.0	H	318.0	-6.2
1597.625000	---	33.11	54.00	20.89	100.0	V	35.0	-5.1
1991.375000	56.79	---	68.20	11.41	200.0	V	28.0	-2.7
2230.250000	---	34.16	54.00	19.84	200.0	V	90.0	-1.7
2688.750000	47.61	---	68.20	20.59	100.0	V	301.0	0.5
2754.375000	---	36.24	54.00	17.76	200.0	V	234.0	0.8
3008.125000	47.80	---	68.20	20.40	200.0	V	159.0	2.0
3522.625000	49.60	---	68.20	18.60	200.0	V	133.0	3.8
3957.500000	---	39.44	54.00	14.56	200.0	H	48.0	5.9
6765.375000	51.39	---	68.20	16.81	100.0	V	176.0	10.5
7553.750000	---	41.51	54.00	12.49	200.0	V	171.0	11.5

Remark: 1. Correction Factor = Antenna factor+ Insertion loss (cable loss + amplifier gain)

802.11ax (HE20) CH157

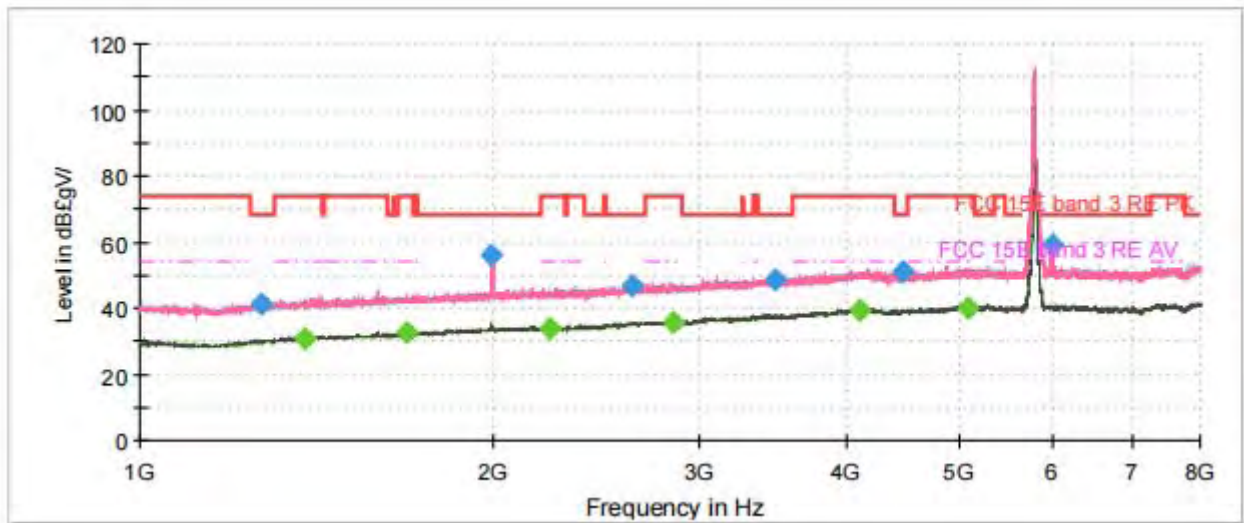

Note: The signal beyond the limit is carrier.
Radiates Emission from 1GHz to 8GHz

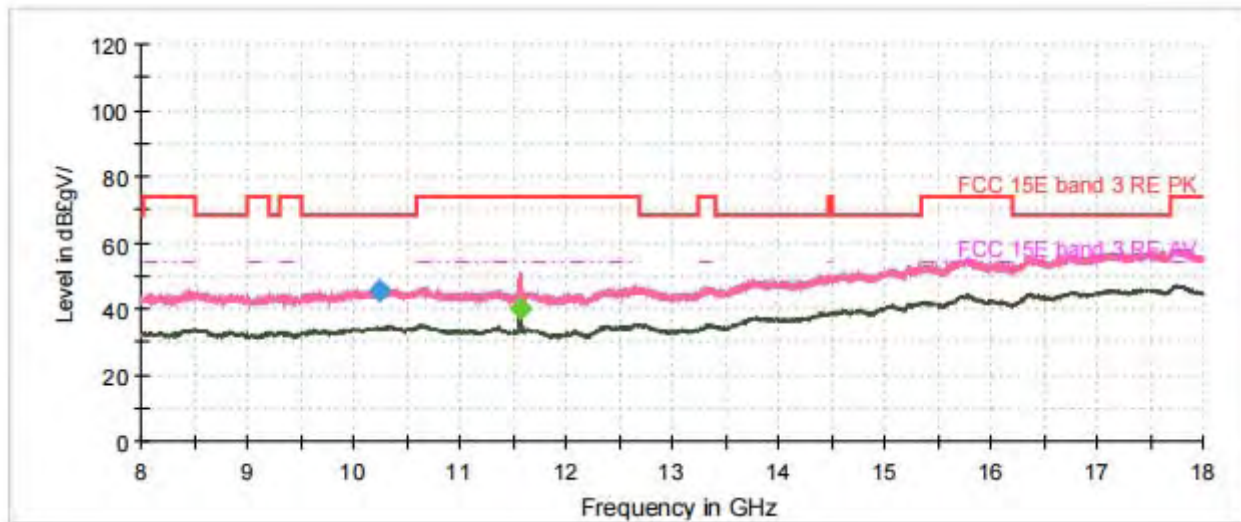

Radiates Emission from 8GHz to 18GHz



Frequency (MHz)	Peak (dBuV/m)	Average (dBuV/m)	Limit (dBuV/m)	Margin (dB)	Height (cm)	Polarization	Azimuth (deg)	Correct Factor (dB)
1269.500000	41.48	---	68.20	26.72	100.0	V	2.0	-6.9
1384.125000	---	30.51	54.00	23.49	200.0	H	4.0	-6.3
1690.375000	---	32.42	54.00	21.58	100.0	V	194.0	-4.5
1990.500000	56.01	---	68.20	12.19	100.0	V	206.0	-2.7
2229.375000	---	34.08	54.00	19.92	100.0	V	224.0	-1.7
2621.375000	46.85	---	68.20	21.35	200.0	V	118.0	0.2
2850.625000	---	35.67	54.00	18.33	200.0	V	185.0	1.1
3473.625000	48.81	---	68.20	19.39	200.0	H	165.0	3.6
4101.000000	---	39.48	54.00	14.52	100.0	H	197.0	6.8
4458.875000	50.78	---	68.20	17.42	100.0	H	135.0	6.4
5083.625000	---	40.21	54.00	13.79	200.0	H	23.0	8.7
5997.125000	59.38	---	68.20	8.82	100.0	V	358.0	9.7

Remark: 1. Correction Factor = Antenna factor+ Insertion loss (cable loss + amplifier gain)

802.11ax (HE20) CH165

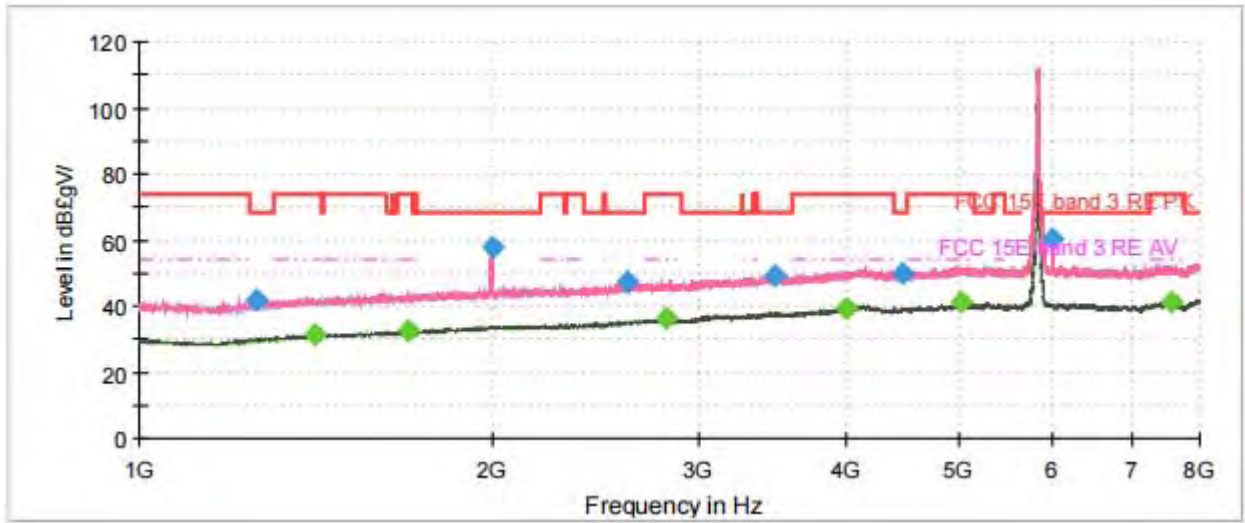

Note: The signal beyond the limit is carrier.
Radiates Emission from 1GHz to 8GHz

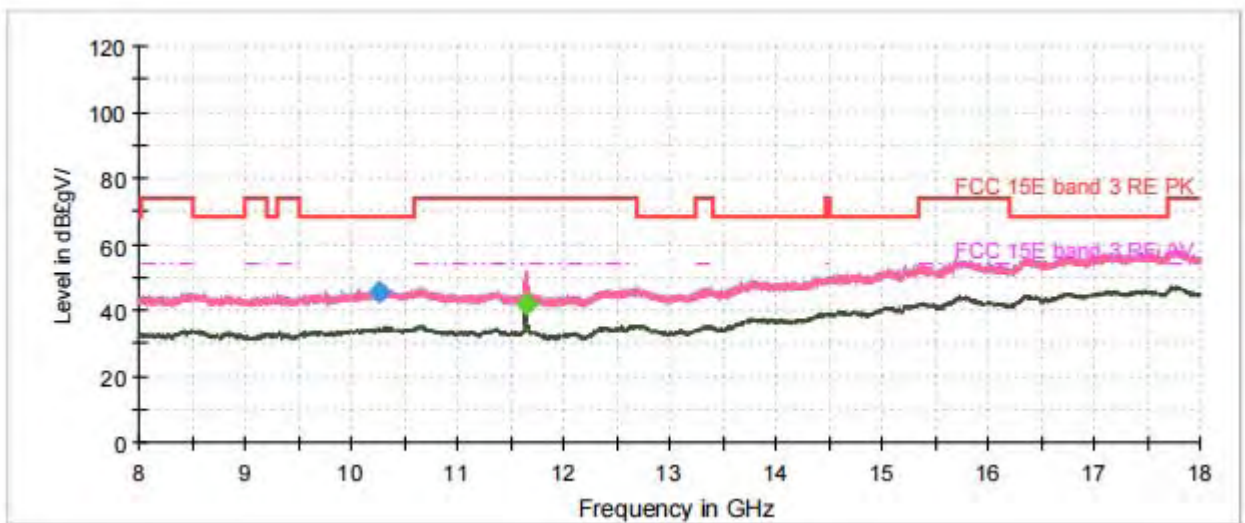

Radiates Emission from 8GHz to 18GHz



Frequency (MHz)	Peak (dBuV/m)	Average (dBuV/m)	Limit (dBuV/m)	Margin (dB)	Height (cm)	Polarization	Azimuth (deg)	Correct Factor (dB)
1255.500000	41.55	---	68.20	26.65	200.0	V	232.0	-7.0
1412.125000	---	31.28	54.00	22.72	200.0	V	33.0	-6.1
1694.750000	---	32.60	54.00	21.40	100.0	H	120.0	-4.5
1999.250000	57.61	---	68.20	10.59	200.0	V	358.0	-2.7
2608.250000	47.45	---	68.20	20.75	200.0	V	63.0	0.1
2805.125000	---	36.03	54.00	17.97	200.0	V	99.0	1.0
3483.250000	49.44	---	68.20	18.76	100.0	H	0.0	3.7
3993.375000	---	39.26	54.00	14.74	200.0	V	214.0	6.1
4467.625000	50.12	---	68.20	18.08	200.0	H	336.0	6.4
5020.625000	---	40.96	54.00	13.04	200.0	H	165.0	8.7
5984.000000	60.49	---	68.20	7.71	100.0	V	78.0	9.7
7570.375000	---	41.16	54.00	12.84	200.0	V	105.0	11.4

Remark: 1. Correction Factor = Antenna factor+ Insertion loss (cable loss + amplifier gain)

802.11ax (HE40) CH38

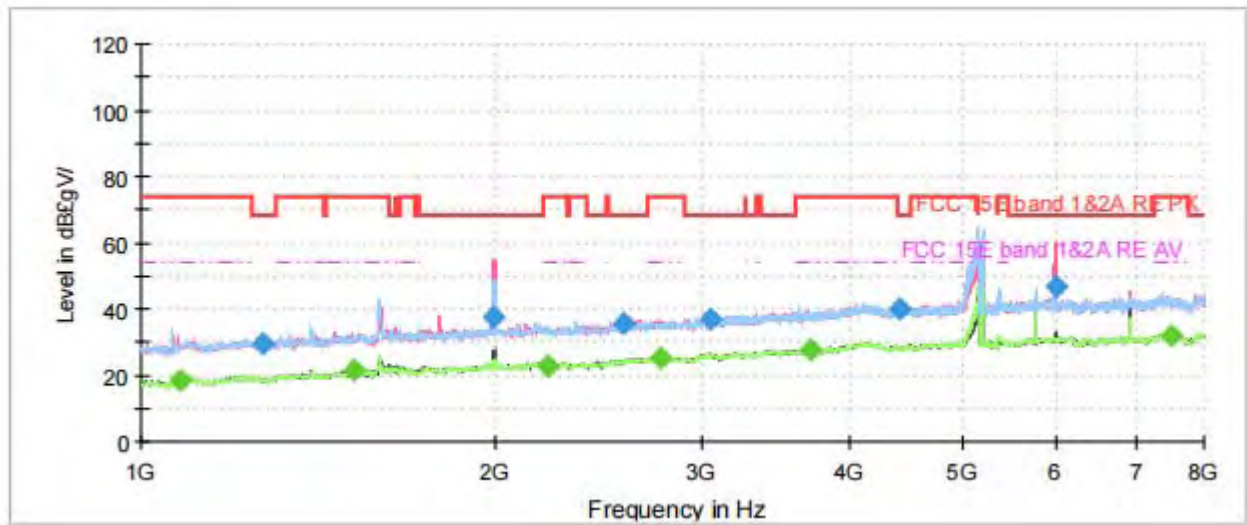

Note: The signal beyond the limit is carrier.
Radiates Emission from 1GHz to 8GHz

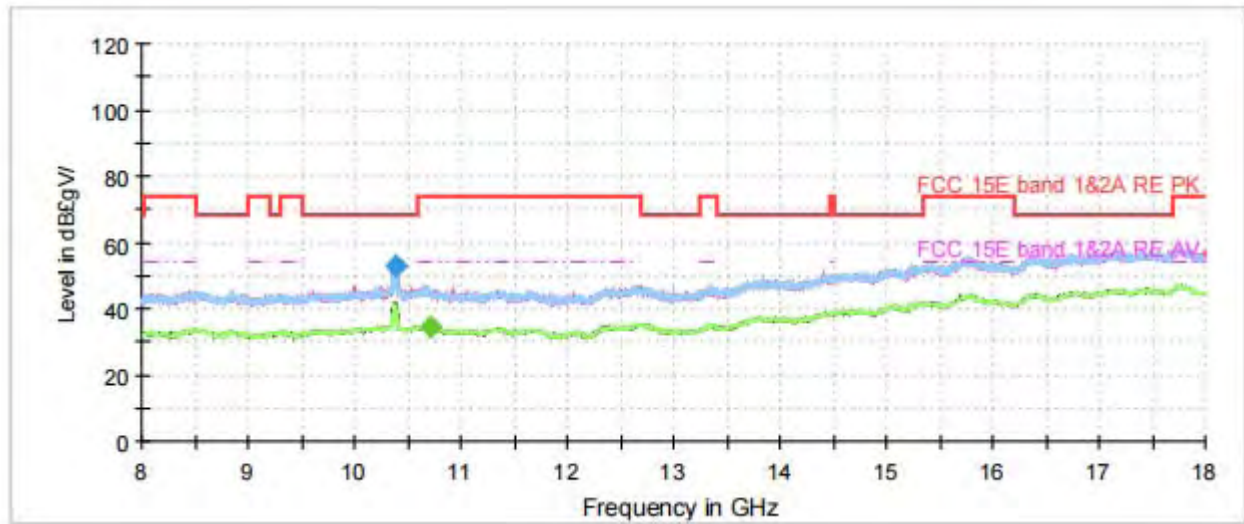

Radiates Emission from 8GHz to 18GHz



Frequency (MHz)	Peak (dBuV/m)	Average (dBuV/m)	Limit (dBuV/m)	Margin (dB)	Height (cm)	Polarization	Azimuth (deg)	Correct Factor (dB)
1077.875000	---	18.60	54.00	35.40	100.0	V	291.0	-17.9
1266.875000	29.63	---	68.20	38.57	100.0	V	236.0	-16.9
1516.250000	---	21.53	54.00	32.47	100.0	V	291.0	-15.5
1995.750000	37.60	---	68.20	30.60	200.0	H	316.0	-12.7
2218.000000	---	22.76	54.00	31.24	100.0	V	160.0	-11.7
2572.375000	35.84	---	68.20	32.36	100.0	H	248.0	-10.1
2767.500000	---	25.10	54.00	28.90	100.0	H	297.0	-9.2
3051.000000	37.04	---	68.20	31.16	100.0	H	248.0	-7.7
3712.500000	---	27.89	54.00	26.11	100.0	H	344.0	-5.5
4409.875000	40.28	---	68.20	27.92	100.0	V	143.0	-3.8
5979.625000	46.87	---	68.20	21.33	100.0	V	78.0	-0.3
7495.125000	---	31.97	54.00	22.03	100.0	V	0.0	1.5

Remark: 1. Correction Factor = Antenna factor+ Insertion loss (cable loss + amplifier gain)

802.11ax (HE40) CH46

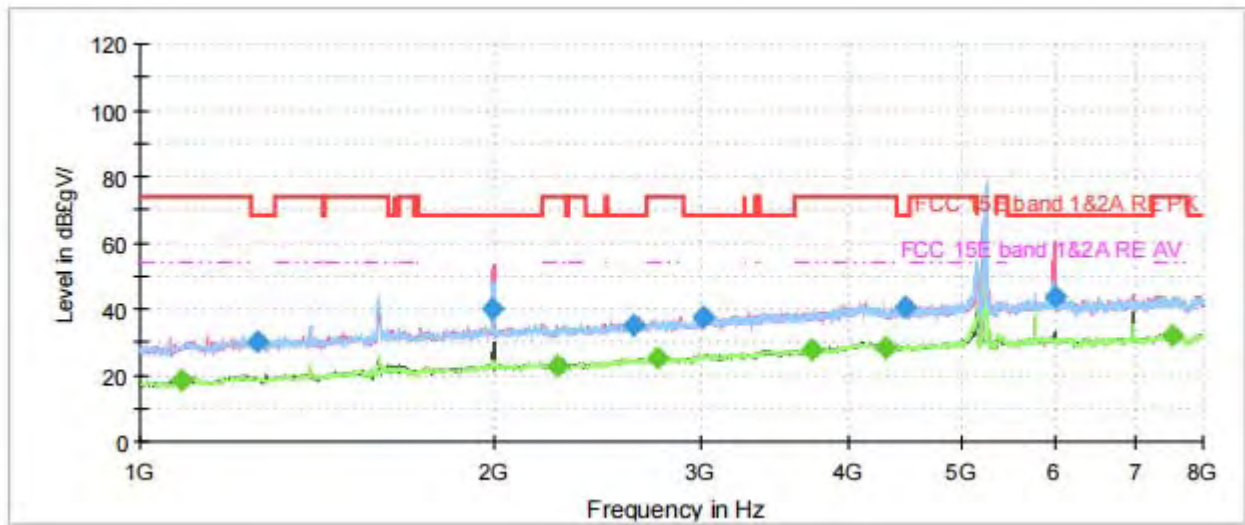

Note: The signal beyond the limit is carrier.
Radiates Emission from 1GHz to 8GHz

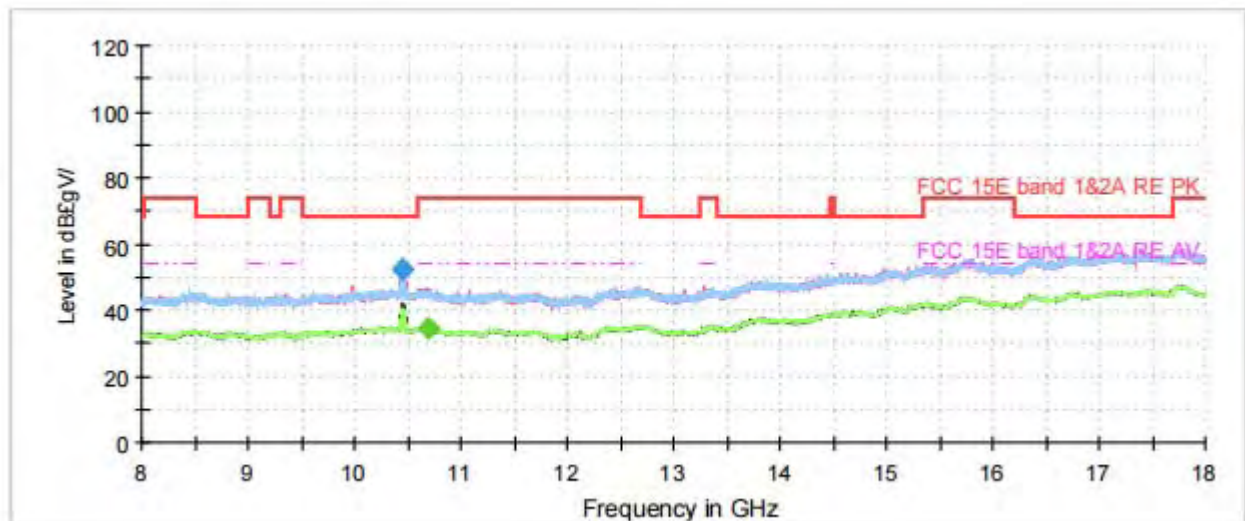

Radiates Emission from 8GHz to 18GHz



Frequency (MHz)	Peak (dBuV/m)	Average (dBuV/m)	Limit (dBuV/m)	Margin (dB)	Height (cm)	Polarization	Azimuth (deg)	Correct Factor (dB)
1084.875000	---	18.77	54.00	35.23	100.0	H	339.0	-17.9
1257.250000	29.94	---	68.20	38.26	200.0	V	215.0	-17.0
1995.750000	40.05	---	68.20	28.15	100.0	H	346.0	-12.7
2261.750000	---	22.81	54.00	31.19	200.0	V	184.0	-11.6
2621.375000	35.37	---	68.20	32.83	100.0	V	220.0	-9.8
2753.500000	---	25.17	54.00	28.83	200.0	H	250.0	-9.2
3002.000000	37.25	---	68.20	30.95	100.0	H	116.0	-8.1
3725.625000	---	27.50	54.00	26.50	200.0	V	283.0	-5.4
4305.750000	---	28.09	54.00	25.91	200.0	V	117.0	-4.0
4470.250000	40.65	---	68.20	27.55	200.0	H	14.0	-3.6
5985.750000	43.52	---	68.20	24.68	200.0	H	129.0	-0.3
7541.500000	---	31.70	54.00	22.30	100.0	H	219.0	1.5

Remark: 1. Correction Factor = Antenna factor+ Insertion loss (cable loss + amplifier gain)

802.11ax (HE40)CH54

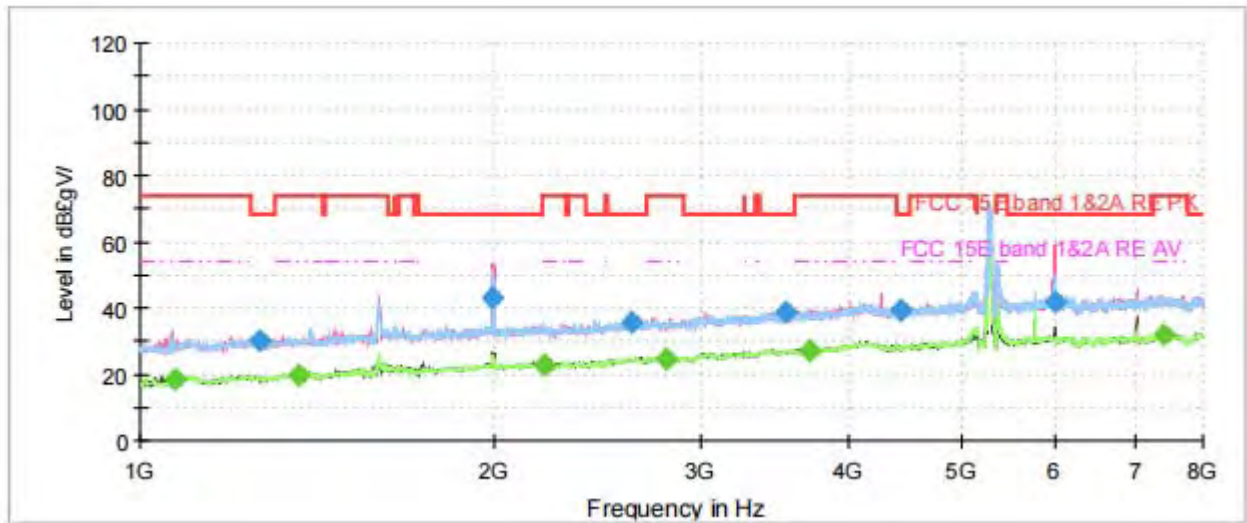

Note: The signal beyond the limit is carrier.
Radiates Emission from 1GHz to 8GHz

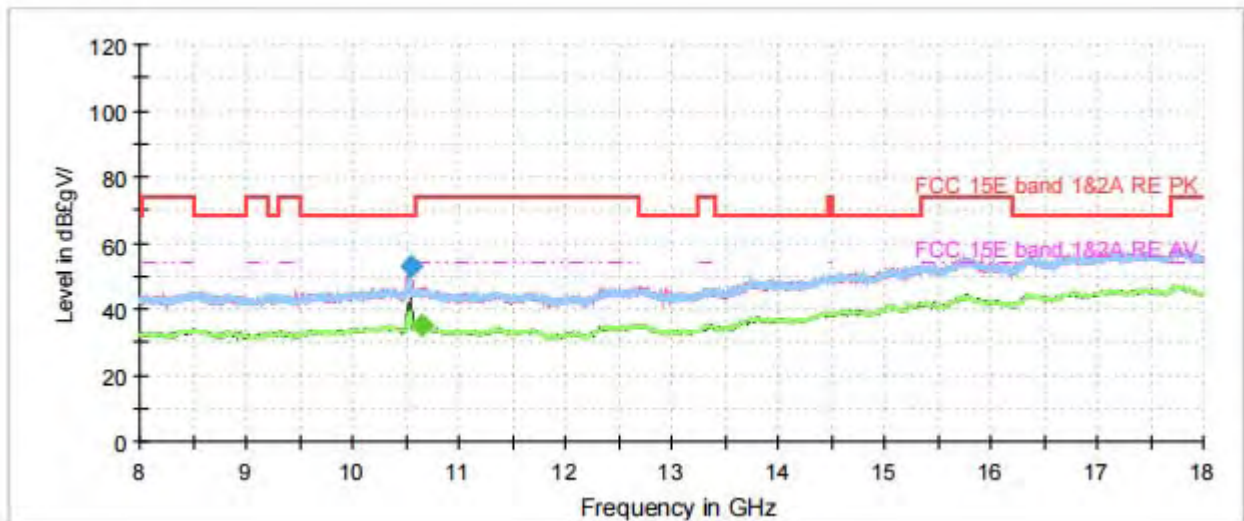

Radiates Emission from 8GHz to 18GHz



Frequency (MHz)	Peak (dBuV/m)	Average (dBuV/m)	Limit (dBuV/m)	Margin (dB)	Height (cm)	Polarization	Azimuth (deg)	Correct Factor (dB)
1072.625000	---	18.16	54.00	35.84	100.0	V	295.0	-18.0
1264.250000	30.10	---	68.20	38.10	100.0	V	306.0	-16.9
1366.625000	---	19.55	54.00	34.45	100.0	H	209.0	-16.4
1995.750000	43.25	---	68.20	24.95	100.0	H	353.0	-12.7
2206.625000	---	22.90	54.00	31.10	100.0	V	253.0	-11.8
2610.000000	35.45	---	68.20	32.75	200.0	V	156.0	-9.9
2798.125000	---	24.67	54.00	29.33	100.0	V	147.0	-9.1
3535.750000	39.03	---	68.20	29.17	200.0	V	271.0	-6.2
3712.500000	---	27.26	54.00	26.74	200.0	V	259.0	-5.5
4438.750000	39.09	---	68.20	29.11	200.0	V	162.0	-3.7
5987.500000	42.07	---	68.20	26.13	200.0	H	241.0	-0.3
7413.750000	---	31.89	54.00	22.11	100.0	V	141.0	1.5

Remark: 1. Correction Factor = Antenna factor+ Insertion loss (cable loss + amplifier gain)

802.11ax (HE40) CH62

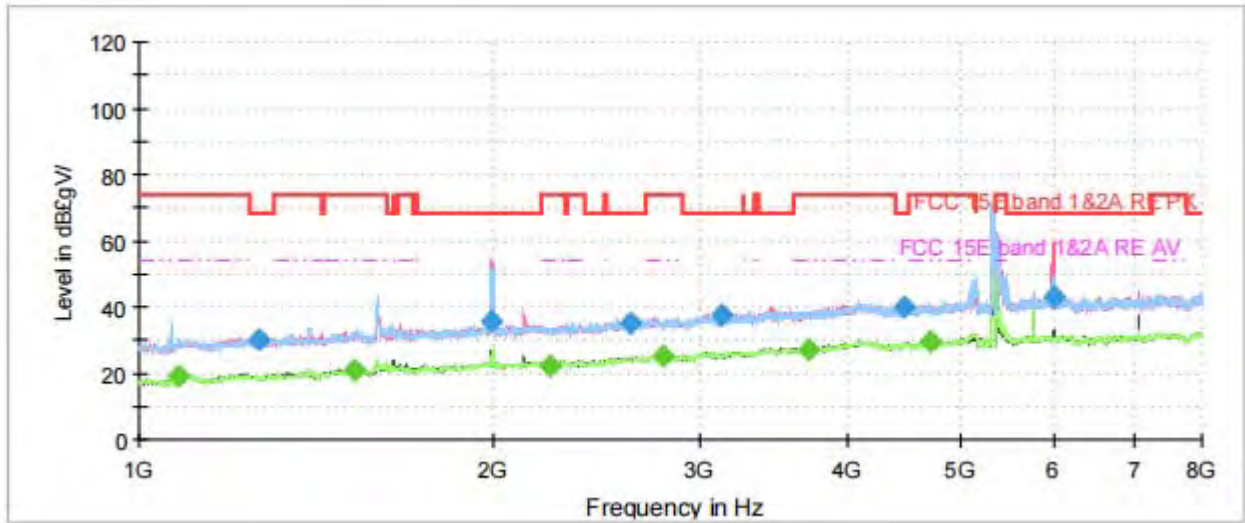

Note: The signal beyond the limit is carrier.
Radiates Emission from 1GHz to 8GHz

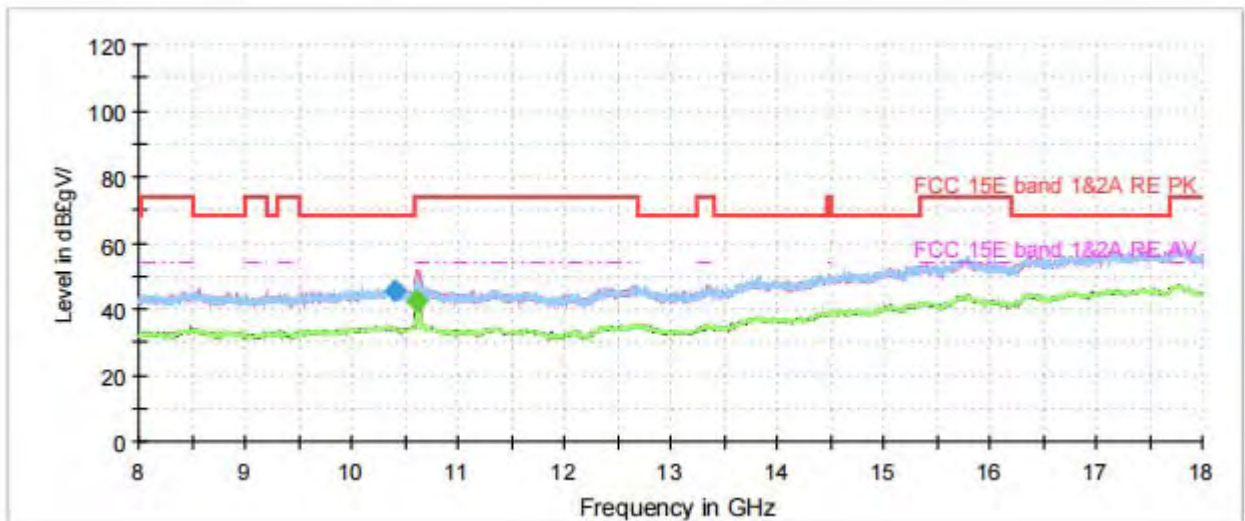

Radiates Emission from 8GHz to 18GHz



Frequency (MHz)	Peak (dBuV/m)	Average (dBuV/m)	Limit (dBuV/m)	Margin (dB)	Height (cm)	Polarization	Azimuth (deg)	Correct Factor (dB)
1079.625000	---	19.18	54.00	34.82	200.0	H	339.0	-17.9
1261.625000	30.31	---	68.20	37.89	100.0	H	156.0	-16.9
1524.125000	---	21.09	54.00	32.91	200.0	V	86.0	-15.4
1991.375000	35.95	---	68.20	32.25	200.0	V	92.0	-12.7
2234.625000	---	22.27	54.00	31.73	100.0	V	219.0	-11.7
2611.750000	35.23	---	68.20	32.97	200.0	V	0.0	-9.9
2785.000000	---	24.94	54.00	29.06	100.0	V	331.0	-9.1
3120.125000	37.24	---	68.20	30.96	200.0	V	185.0	-7.5
3712.500000	---	27.18	54.00	26.82	100.0	V	337.0	-5.5
4475.500000	39.71	---	68.20	28.49	100.0	V	271.0	-3.6
4707.375000	---	29.40	54.00	24.60	100.0	H	2.0	-2.9
5985.750000	43.29	---	68.20	24.91	200.0	H	274.0	-0.3

Remark: 1. Correction Factor = Antenna factor+ Insertion loss (cable loss + amplifier gain)

802.11ax (HE40)CH102

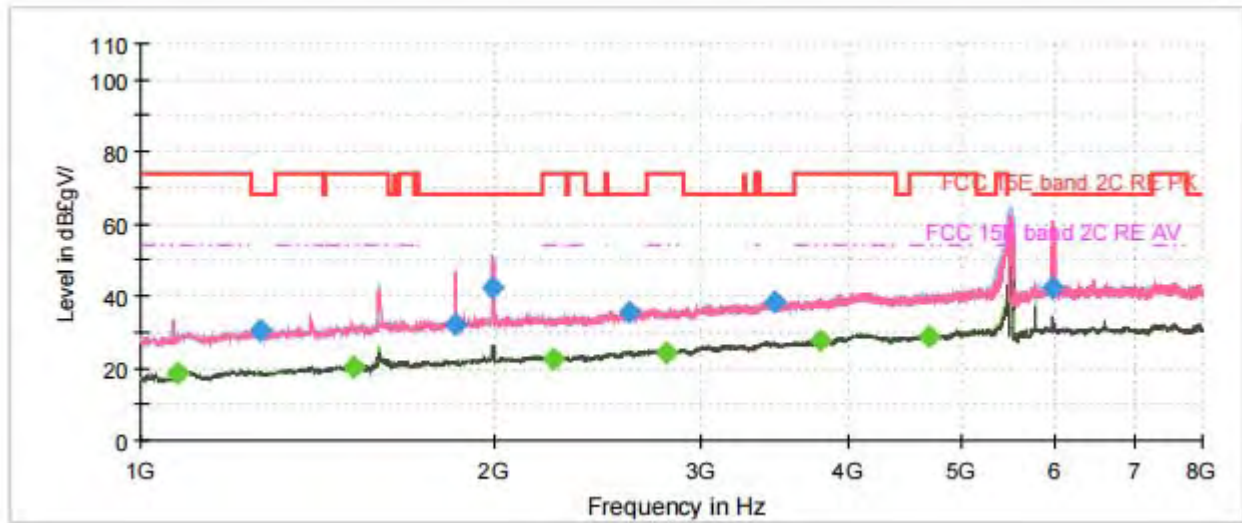

Radiates Emission from 1GHz to 8GHz

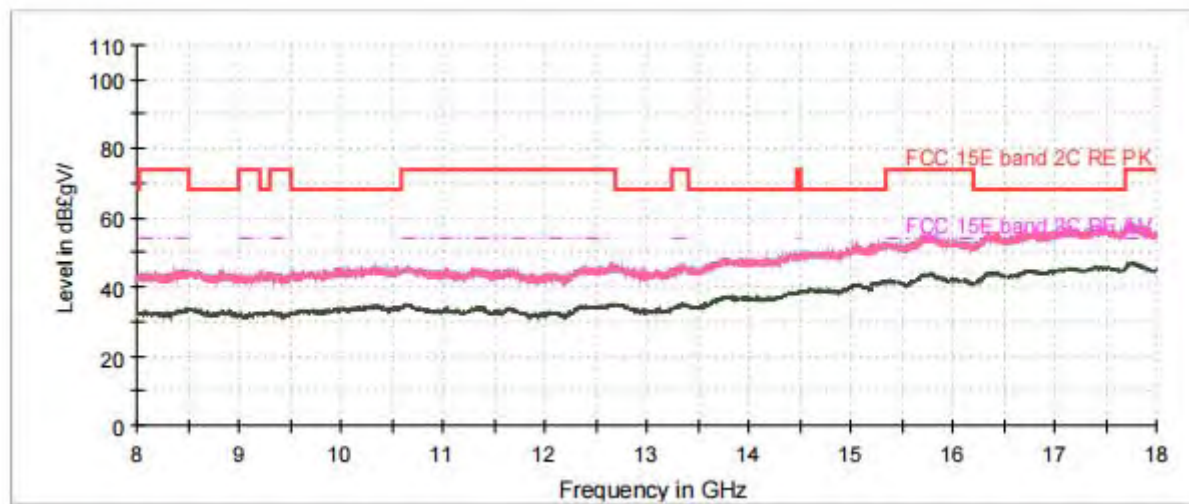

Radiates Emission from 8GHz to 18GHz



Frequency (MHz)	Peak (dBuV/m)	Average (dBuV/m)	Limit (dBuV/m)	Margin (dB)	Height (cm)	Polarization	Azimuth (deg)	Correct Factor (dB)
1073.500000	---	18.43	54.00	35.57	200.0	V	197.0	-18.0
1261.625000	30.36	---	68.20	37.84	200.0	H	234.0	-16.9
1515.375000	---	20.50	54.00	33.50	200.0	H	129.0	-15.5
1854.875000	32.32	---	68.20	35.88	200.0	H	210.0	-13.6
1994.875000	42.41	---	68.20	25.79	200.0	H	2.0	-12.7
2242.500000	---	22.58	54.00	31.42	200.0	H	335.0	-11.7
2602.125000	35.70	---	68.20	32.50	200.0	H	330.0	-10.0
2792.875000	---	24.38	54.00	29.62	200.0	H	280.0	-9.1
3468.375000	38.60	---	68.20	29.60	200.0	V	19.0	-6.4
3790.375000	---	27.71	54.00	26.29	200.0	H	341.0	-5.1
4687.250000	---	28.84	54.00	25.16	100.0	H	3.0	-3.0
5977.875000	42.10	---	68.20	26.10	100.0	H	176.0	-0.3

Remark: 1. Correction Factor = Antenna factor+ Insertion loss (cable loss + amplifier gain)

802.11ax (HE40) CH118

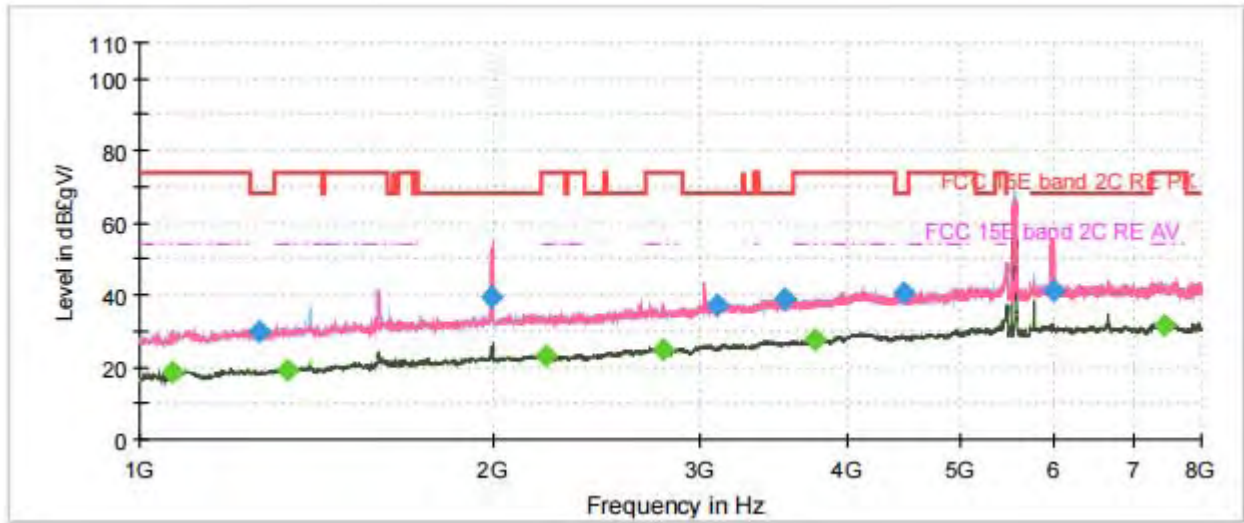

Note: The signal beyond the limit is carrier.
Radiates Emission from 1GHz to 8GHz

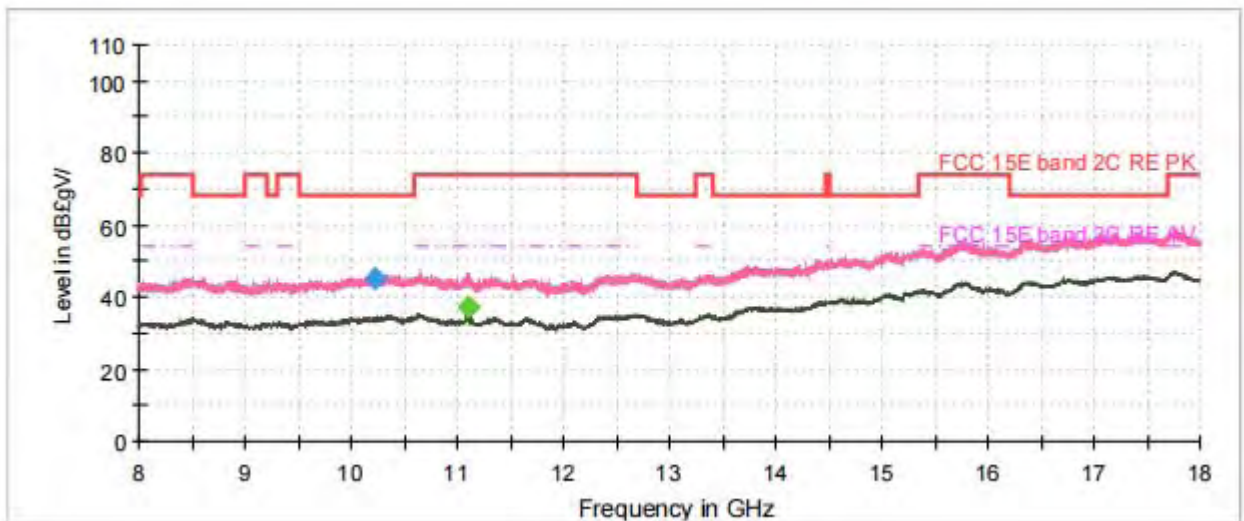

Radiates Emission from 8GHz to 18GHz



Frequency (MHz)	Peak (dBuV/m)	Average (dBuV/m)	Limit (dBuV/m)	Margin (dB)	Height (cm)	Polarization	Azimuth (deg)	Correct Factor (dB)
1066.500000	---	18.37	54.00	35.63	200.0	H	45.0	-18.0
1264.250000	29.90	---	68.20	38.30	200.0	H	161.0	-16.9
1335.125000	---	19.36	54.00	34.64	200.0	V	47.0	-16.6
1995.750000	39.57	---	68.20	28.63	200.0	H	239.0	-12.7
2211.875000	---	22.87	54.00	31.13	200.0	H	195.0	-11.7
2785.875000	---	24.64	54.00	29.36	100.0	H	56.0	-9.1
3096.500000	37.32	---	68.20	30.88	200.0	V	136.0	-7.5
3540.125000	38.79	---	68.20	29.41	100.0	H	329.0	-6.2
3758.875000	---	27.53	54.00	26.47	200.0	V	277.0	-5.2
4471.125000	40.58	---	68.20	27.62	200.0	H	161.0	-3.6
5989.250000	41.00	---	68.20	27.20	100.0	H	4.0	-0.3
7432.125000	---	31.36	54.00	22.64	200.0	H	222.0	1.5

Remark: 1. Correction Factor = Antenna factor+ Insertion loss (cable loss + amplifier gain)

802.11ax (HE40) CH134

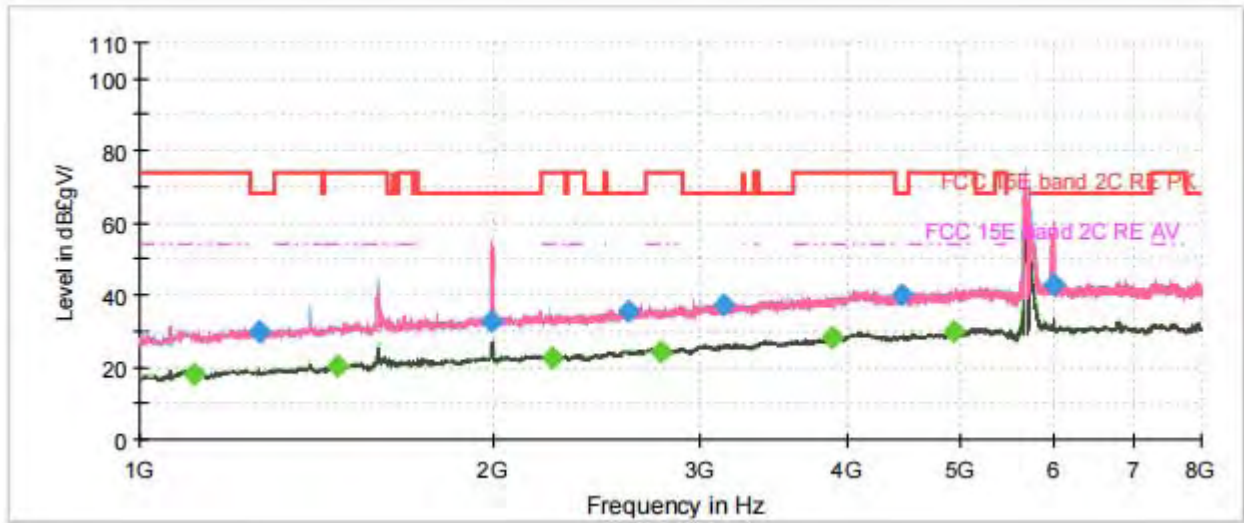

Note: The signal beyond the limit is carrier.
Radiates Emission from 1GHz to 8GHz

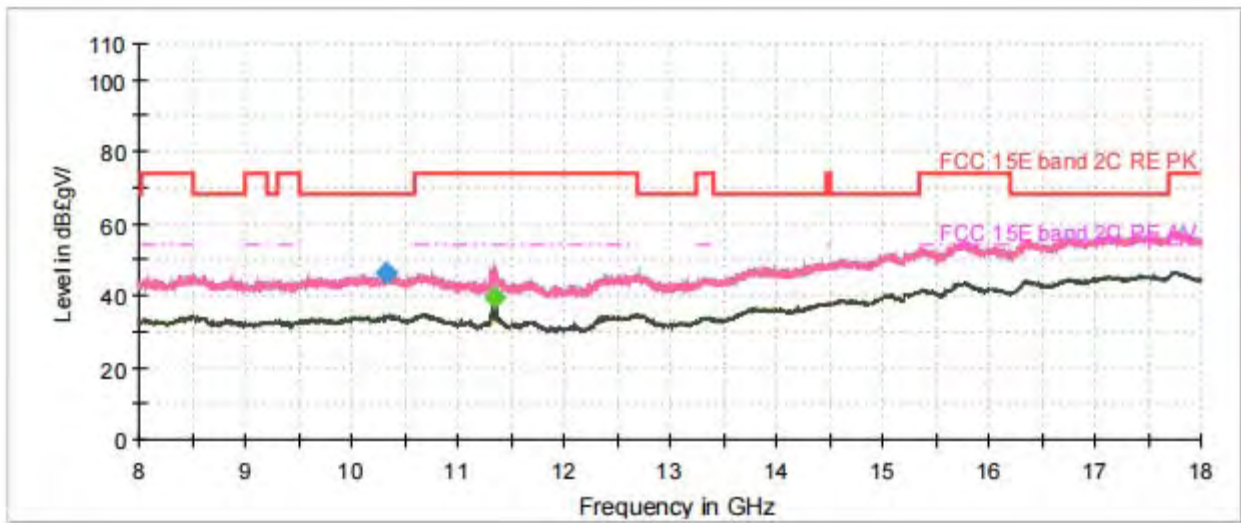

Radiates Emission from 8GHz to 18GHz



Frequency (MHz)	Peak (dBuV/m)	Average (dBuV/m)	Limit (dBuV/m)	Margin (dB)	Height (cm)	Polarization	Azimuth (deg)	Correct Factor (dB)
1113.750000	---	18.26	54.00	35.74	200.0	H	100.0	-17.7
1261.625000	30.11	---	68.20	38.09	100.0	H	330.0	-16.9
1475.125000	---	20.46	54.00	33.54	200.0	H	223.0	-15.7
1992.250000	32.94	---	68.20	35.26	100.0	H	0.0	-12.7
2247.750000	---	22.34	54.00	31.66	200.0	H	294.0	-11.7
2603.875000	35.30	---	68.20	32.90	100.0	H	189.0	-9.9
2774.500000	---	24.39	54.00	29.61	200.0	H	270.0	-9.2
3139.375000	37.44	---	68.20	30.76	100.0	H	166.0	-7.5
3880.500000	---	28.01	54.00	25.99	100.0	H	160.0	-4.6
4443.125000	39.89	---	68.20	28.32	100.0	H	194.0	-3.7
4924.375000	---	29.87	54.00	24.13	100.0	H	177.0	-1.8
5987.500000	42.78	---	68.20	25.42	200.0	V	43.0	-0.3

Remark: 1. Correction Factor = Antenna factor+ Insertion loss (cable loss + amplifier gain)

802.11ax (HE40) CH151

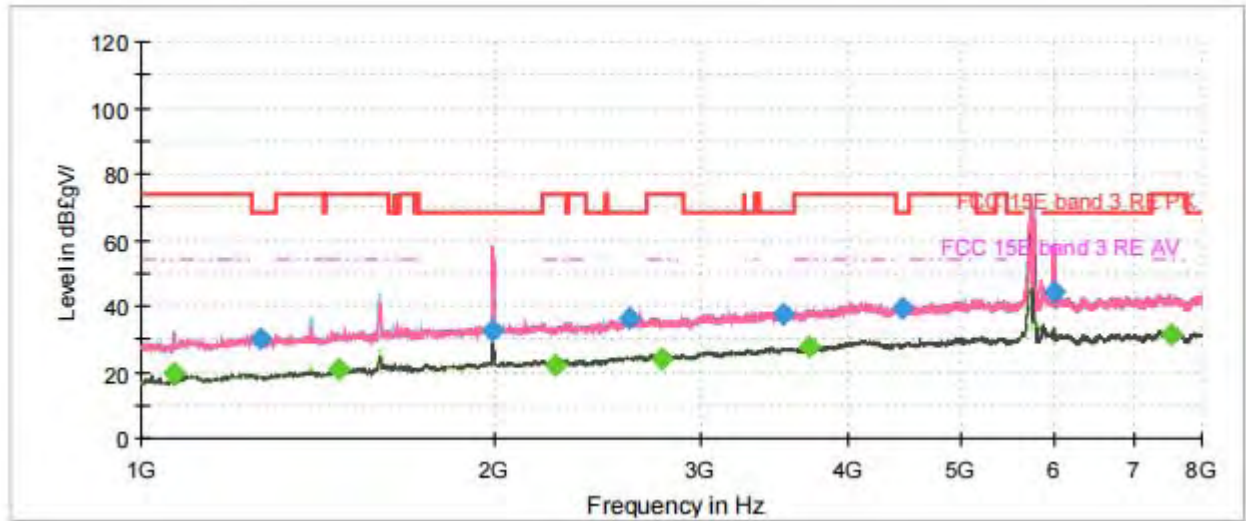

Note: The signal beyond the limit is carrier.
Radiates Emission from 1GHz to 8GHz

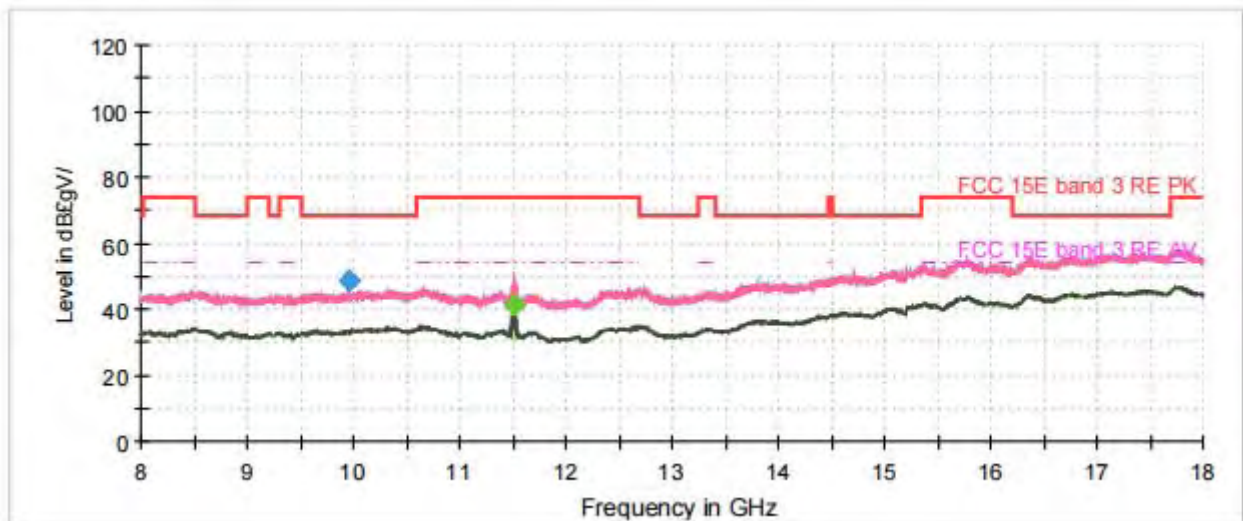

Radiates Emission from 8GHz to 18GHz



Frequency (MHz)	Peak (dBuV/m)	Average (dBuV/m)	Limit (dBuV/m)	Margin (dB)	Height (cm)	Polarization	Azimuth (deg)	Correct Factor (dB)
1064.750000	---	19.79	54.00	34.21	100.0	V	8.0	-18.0
1265.125000	29.95	---	68.20	38.25	100.0	H	93.0	-16.9
1475.125000	---	20.67	54.00	33.33	100.0	H	343.0	-15.7
1994.875000	32.38	---	68.20	35.82	200.0	H	0.0	-12.7
2253.875000	---	22.04	54.00	31.96	100.0	H	199.0	-11.6
2603.875000	36.21	---	68.20	31.99	200.0	H	256.0	-9.9
2778.000000	---	24.13	54.00	29.87	100.0	H	24.0	-9.1
3521.750000	37.77	---	68.20	30.43	100.0	H	42.0	-6.2
3712.500000	---	27.67	54.00	26.33	200.0	V	104.0	-5.5
4444.000000	39.65	---	68.20	28.55	200.0	H	283.0	-3.7
5985.750000	44.13	---	68.20	24.07	100.0	V	318.0	-0.3
7542.375000	---	31.41	54.00	22.59	100.0	H	128.0	1.5

Remark: 1. Correction Factor = Antenna factor+ Insertion loss (cable loss + amplifier gain)

802.11ax (HE40) CH159

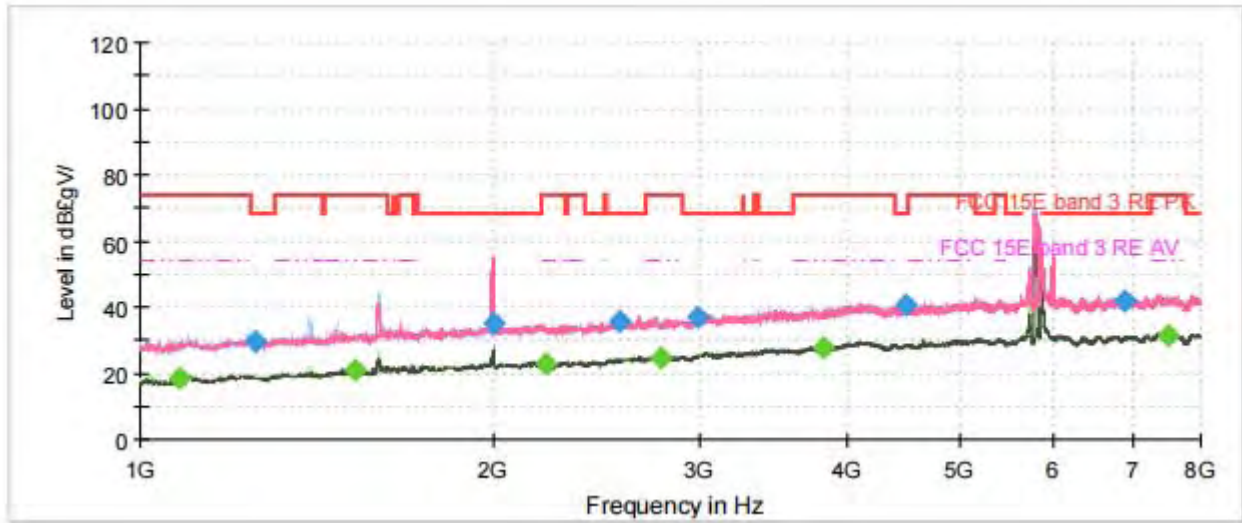

Note: The signal beyond the limit is carrier.
Radiates Emission from 1GHz to 8GHz

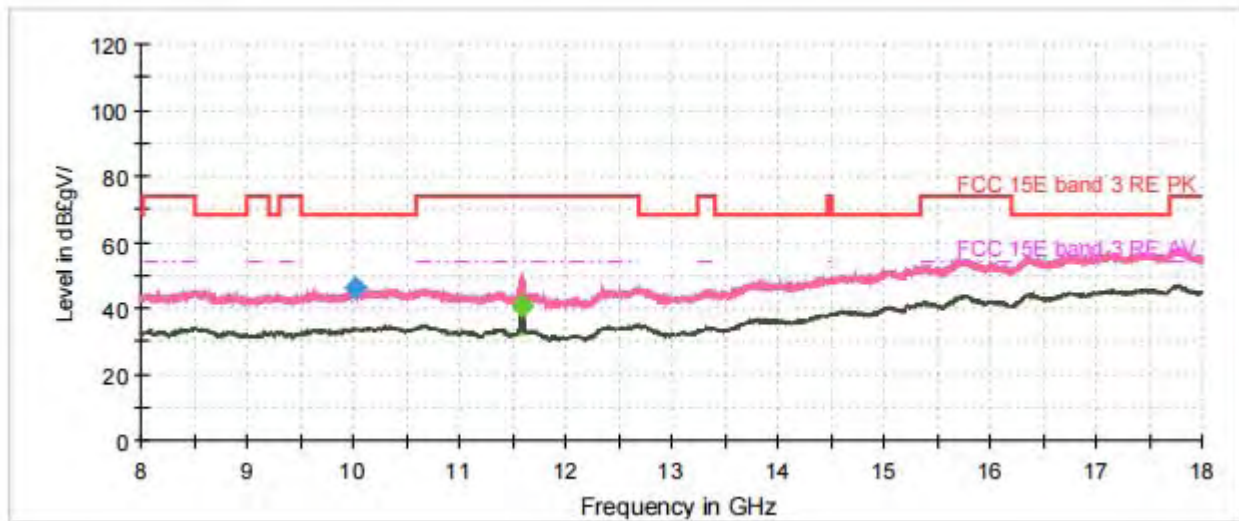

Radiates Emission from 8GHz to 18GHz



Frequency (MHz)	Peak (dBuV/m)	Average (dBuV/m)	Limit (dBuV/m)	Margin (dB)	Height (cm)	Polarization	Azimuth (deg)	Correct Factor (dB)
1079.625000	---	18.31	54.00	35.69	100.0	H	277.0	-17.9
1251.125000	29.43	---	68.20	38.77	100.0	H	295.0	-17.0
1525.000000	---	21.21	54.00	32.79	100.0	V	290.0	-15.4
1998.375000	34.83	---	68.20	33.37	100.0	V	221.0	-12.7
2216.250000	---	22.92	54.00	31.08	100.0	H	147.0	-11.7
2563.625000	35.70	---	68.20	32.50	200.0	V	59.0	-10.2
2771.000000	---	24.55	54.00	29.45	200.0	H	26.0	-9.2
2983.625000	36.66	---	68.20	31.54	100.0	V	245.0	-8.2
3815.750000	---	27.83	54.00	26.17	200.0	V	197.0	-4.9
4479.000000	40.92	---	68.20	27.28	100.0	H	0.0	-3.6
6882.625000	41.88	---	68.20	26.32	100.0	H	40.0	0.7
7496.000000	---	31.24	54.00	22.76	200.0	H	79.0	1.5

Remark: 1. Correction Factor = Antenna factor+ Insertion loss (cable loss + amplifier gain)

802.11ax (HE80) CH42

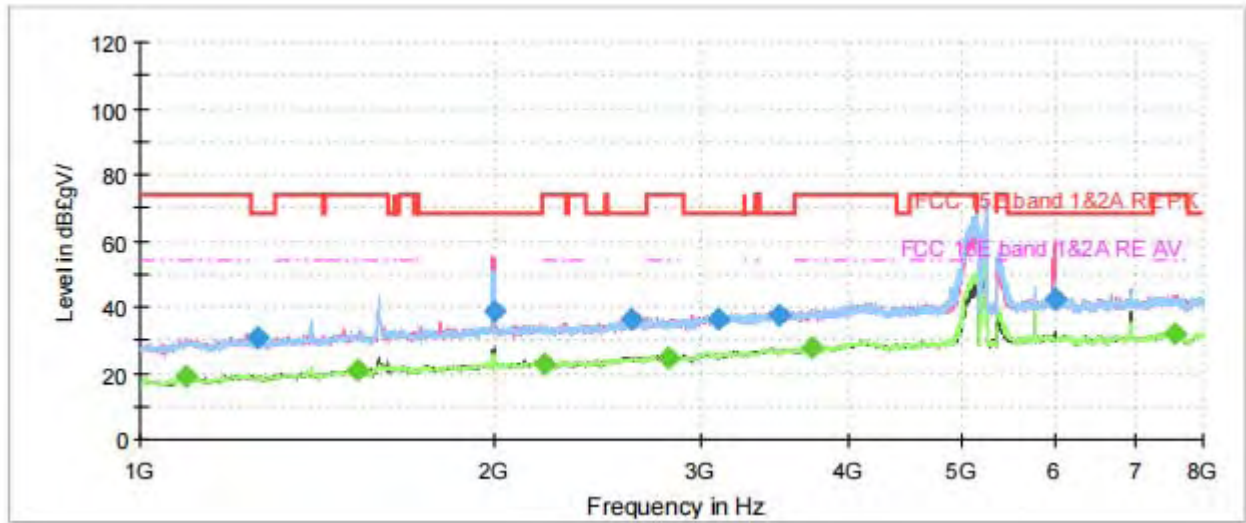

Note: The signal beyond the limit is carrier.
Radiates Emission from 1GHz to 8GHz

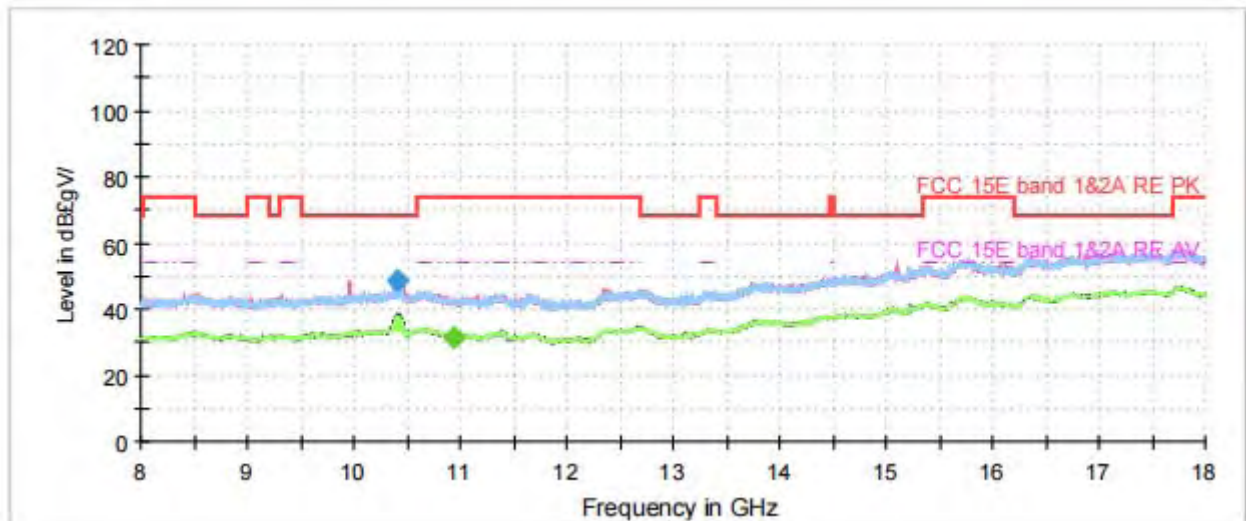

Radiates Emission from 8GHz to 18GHz



Frequency (MHz)	Peak (dBuV/m)	Average (dBuV/m)	Limit (dBuV/m)	Margin (dB)	Height (cm)	Polarization	Azimuth (deg)	Correct Factor (dB)
1092.750000	---	19.02	54.00	34.98	200.0	H	355.0	-17.8
1258.125000	30.88	---	68.20	37.32	200.0	H	0.0	-17.0
1527.625000	---	21.12	54.00	32.88	200.0	V	105.0	-15.4
1996.625000	38.94	---	68.20	29.26	100.0	H	20.0	-12.7
2208.375000	---	22.97	54.00	31.03	200.0	H	206.0	-11.7
2610.875000	36.14	---	68.20	32.06	200.0	H	72.0	-9.9
2814.750000	---	24.69	54.00	29.31	100.0	V	328.0	-9.0
3101.750000	36.54	---	68.20	31.66	200.0	H	206.0	-7.5
3492.000000	37.80	---	68.20	30.40	200.0	H	320.0	-6.3
3722.125000	---	27.41	54.00	26.59	100.0	V	328.0	-5.4
5981.375000	42.45	---	68.20	25.75	100.0	H	138.0	-0.3
7566.875000	---	31.92	54.00	22.08	100.0	H	48.0	1.4

Remark: 1. Correction Factor = Antenna factor+ Insertion loss (cable loss + amplifier gain)

802.11ax (HE80) CH58

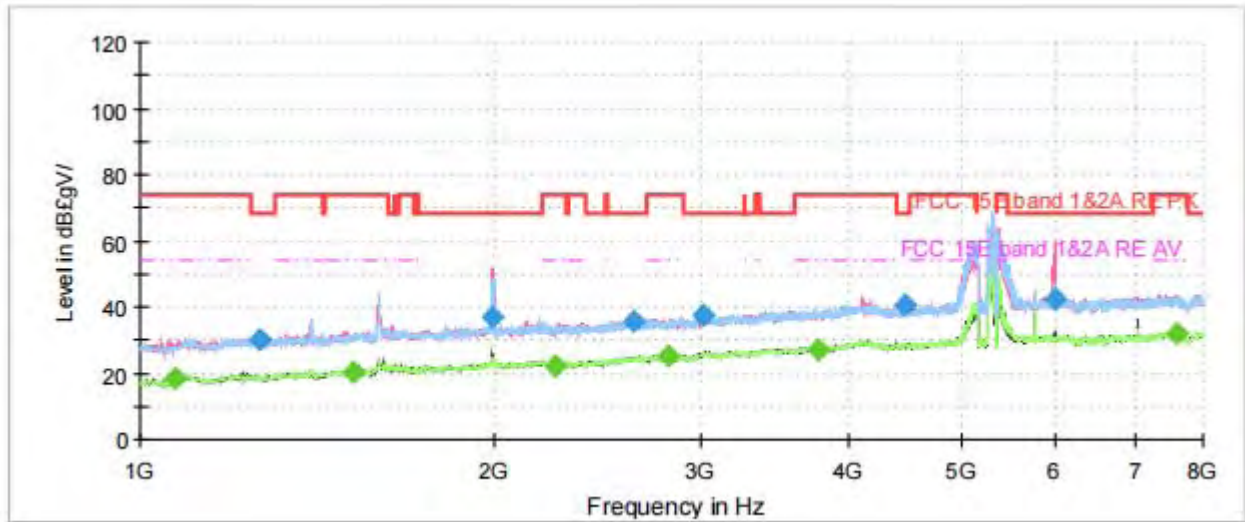

Note: The signal beyond the limit is carrier.
Radiates Emission from 1GHz to 8GHz

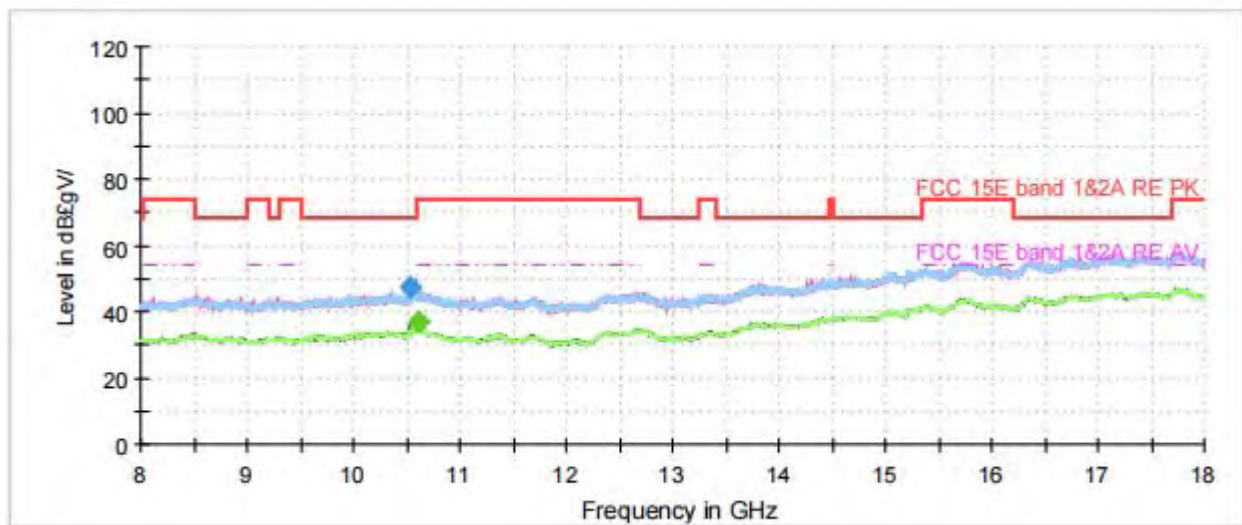

Radiates Emission from 8GHz to 18GHz



Frequency (MHz)	Peak (dBuV/m)	Average (dBuV/m)	Limit (dBuV/m)	Margin (dB)	Height (cm)	Polarization	Azimuth (deg)	Correct Factor (dB)
1070.875000	---	18.56	54.00	35.44	200.0	V	78.0	-18.0
1261.625000	30.20	---	68.20	38.00	200.0	H	312.0	-16.9
1515.375000	---	20.58	54.00	33.42	200.0	V	95.0	-15.5
1994.000000	36.78	---	68.20	31.42	100.0	V	206.0	-12.7
2251.250000	---	22.11	54.00	31.89	100.0	V	135.0	-11.6
2624.000000	35.65	---	68.20	32.55	100.0	H	20.0	-9.8
2811.250000	---	24.95	54.00	29.05	200.0	V	238.0	-9.0
3002.000000	37.31	---	68.20	30.89	200.0	H	336.0	-8.1
3761.500000	---	27.10	54.00	26.90	100.0	V	235.0	-5.2
4465.000000	40.34	---	68.20	27.86	200.0	V	139.0	-3.6
5985.750000	42.52	---	68.20	25.68	100.0	H	140.0	-0.3
7597.500000	---	31.79	54.00	22.21	100.0	V	200.0	1.4

Remark: 1. Correction Factor = Antenna factor+ Insertion loss (cable loss + amplifier gain)

802.11ax (HE80) CH106

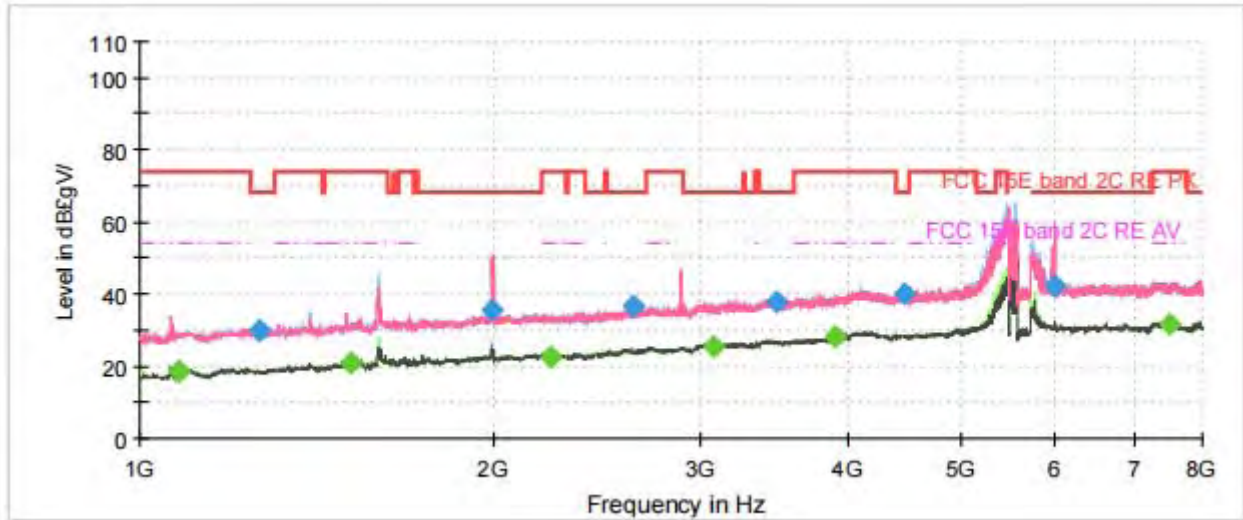

Note: The signal beyond the limit is carrier.
Radiates Emission from 1GHz to 8GHz

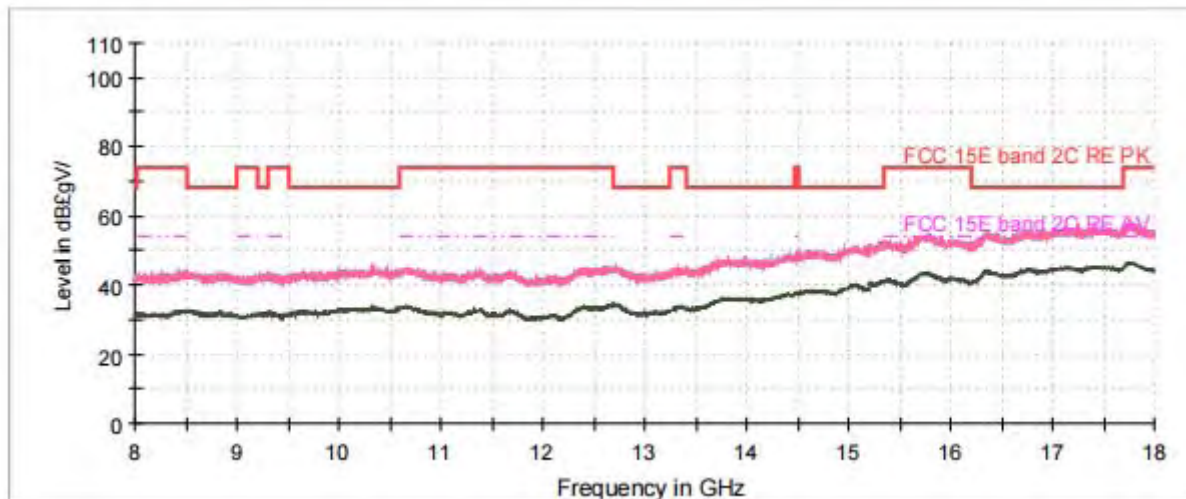

Radiates Emission from 8GHz to 18GHz



Frequency (MHz)	Peak (dBuV/m)	Average (dBuV/m)	Limit (dBuV/m)	Margin (dB)	Height (cm)	Polarization	Azimuth (deg)	Correct Factor (dB)
1079.625000	---	18.36	54.00	35.64	200.0	H	304.0	-17.9
1262.500000	29.91	---	68.20	38.29	100.0	H	277.0	-16.9
1511.000000	---	21.09	54.00	32.91	100.0	V	126.0	-15.5
1993.125000	35.58	---	68.20	32.62	200.0	H	280.0	-12.7
2233.750000	---	22.68	54.00	31.32	200.0	H	232.0	-11.7
2623.125000	36.79	---	68.20	31.41	200.0	V	50.0	-9.8
2721.125000	---	25.42	54.00	28.58	100.0	H	207.0	-7.6
3479.750000	37.89	---	68.20	30.31	200.0	H	304.0	-6.3
3906.750000	---	28.12	54.00	25.88	200.0	H	274.0	-4.5
4463.250000	39.79	---	68.20	28.41	100.0	H	231.0	-3.6
5988.375000	42.39	---	68.20	25.81	100.0	H	326.0	-0.3
7496.000000	---	31.33	54.00	22.67	100.0	V	120.0	1.5

Remark: 1. Correction Factor = Antenna factor+ Insertion loss (cable loss + amplifier gain)



802.11ax (HE80) CH138

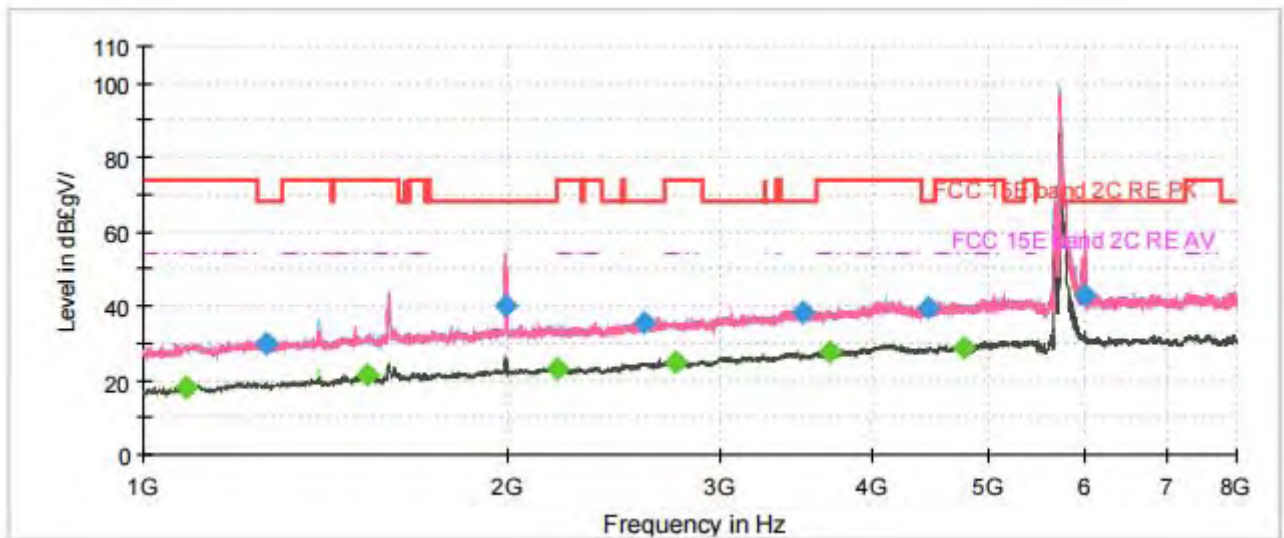

Note: The signal beyond the limit is carrier.
Radiates Emission from 1GHz to 8GHz

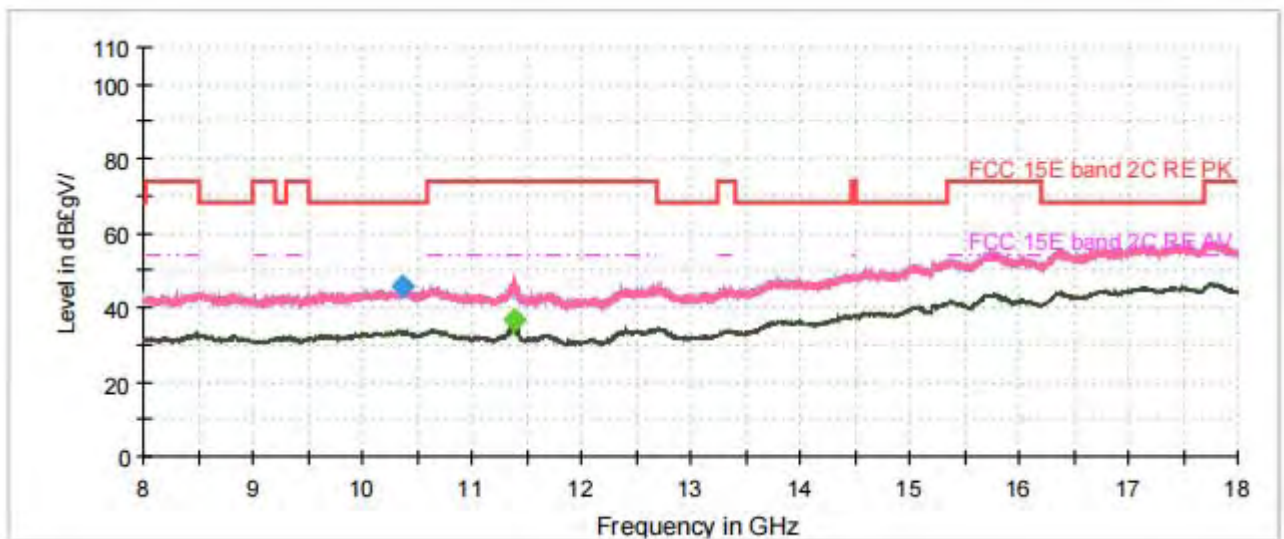

Radiates Emission from 8GHz to 18GHz



Frequency (MHz)	Peak (dBuV/m)	Average (dBuV/m)	Limit (dBuV/m)	Margin (dB)	Height (cm)	Polarization	Azimuth (deg)	Correct Factor (dB)
1082.250000	---	18.24	54.00	35.76	100.0	H	0.0	-17.9
1265.125000	29.98	---	68.20	38.22	200.0	H	283.0	-16.9
1532.000000	---	21.23	54.00	32.77	200.0	V	94.0	-15.4
1993.125000	40.31	---	68.20	27.89	100.0	V	305.0	-12.7
2200.500000	---	22.86	54.00	31.14	100.0	H	150.0	-11.8
2590.750000	35.35	---	68.20	32.85	200.0	V	59.0	-10.0
2756.125000	---	24.89	54.00	29.11	100.0	V	293.0	-9.2
3501.625000	38.61	---	68.20	29.59	200.0	V	0.0	-6.3
3694.125000	---	27.70	54.00	26.30	200.0	H	353.0	-5.5
4450.125000	39.50	---	68.20	28.70	200.0	V	249.0	-3.7
4760.750000	---	28.60	54.00	25.40	100.0	H	25.0	-2.8
5982.250000	43.12	---	68.20	25.08	100.0	H	167.0	-0.3

Remark: 1. Correction Factor = Antenna factor+ Insertion loss (cable loss + amplifier gain)

5.6. Conducted Emission

Ambient condition

Temperature	Relative humidity	Pressure
23°C ~25°C	45%~50%	101.5kPa

Methods of Measurement

The EUT IS placed on a non-metallic table of 80cm height above the horizontal metal reference ground plane. During the test, the EUT was operating in its typical mode. The test method is according to ANSI C63.10. Connect the AC power line of the EUT to the LISN Use EMI receiver to detect the average and Quasi-peak value. RBW is set to 9kHz, VBW is set to 30kHz The measurement result should include both L line and N line.

The test is in transmitting mode.

Test Setup

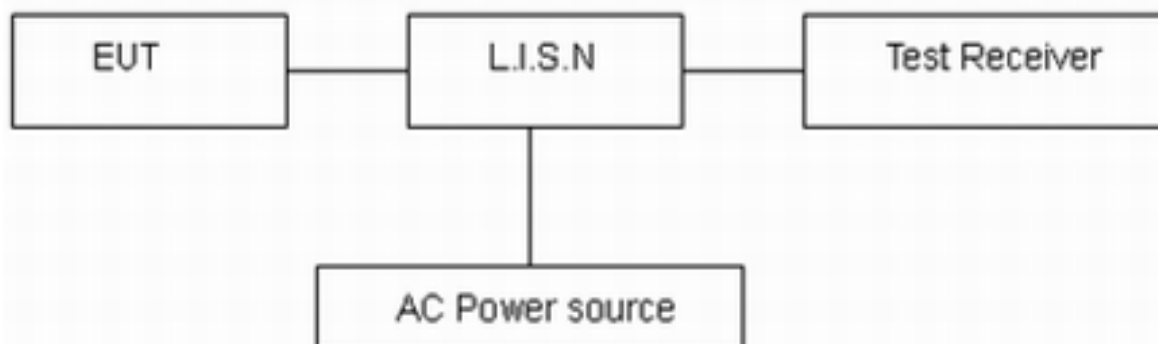

Note: AC Power source is used to change the voltage 110V/60Hz.

Limits

Frequency (MHz)	Conducted Limits(dBμV)	
	Quasi-peak	Average
0.15 - 0.5	66 to 56 *	56 to 46 *
0.5 - 5	56	46
5 - 30	60	50

*: Decreases with the logarithm of the frequency.

Measurement Uncertainty

The assessed measurement uncertainty to ensure 95% confidence level for the normal distribution is with the coverage factor $k = 1.96$, $U = 2.69$ dB.

**Test Results:**

Following plots, Blue trace uses the peak detection and Green trace uses the average detection. During the test, the Conducted Emission was performed in all modes with all channels, 802.11ax HE20 Channel 36 are selected as the worst condition. The test data of the worst-case condition was recorded in this report.

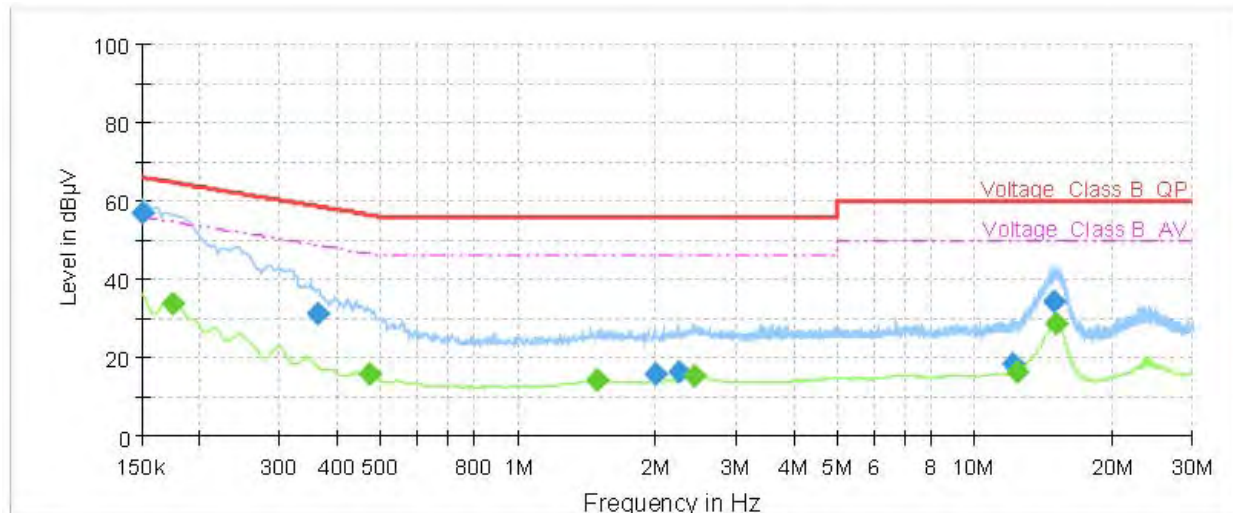

Frequency (MHz)	QuasiPeak (dBµV)	Average (dBµV)	Limit (dBµV)	Margin (dB)	Meas. Time (ms)	Bandwidth (kHz)	Line	Filter	Corr. (dB)
0.15	56.79	---	66.00	9.21	70.0	9.000	L1	ON	21
0.17	---	33.68	54.73	21.05	70.0	9.000	L1	ON	21
0.36	31.40	---	58.64	27.24	70.0	9.000	L1	ON	21
0.47	---	15.91	46.44	30.53	70.0	9.000	L1	ON	20
1.48	---	14.41	46.00	31.59	70.0	9.000	L1	ON	20
2.00	15.68	---	56.00	40.32	70.0	9.000	L1	ON	20
2.26	16.55	---	56.00	39.45	70.0	9.000	L1	ON	19
2.43	---	15.23	46.00	30.77	70.0	9.000	L1	ON	19
12.16	18.53	---	60.00	41.47	70.0	9.000	L1	ON	20
12.40	---	16.31	50.00	33.69	70.0	9.000	L1	ON	20
14.91	34.39	---	60.00	25.61	70.0	9.000	L1	ON	20
15.06	---	28.48	50.00	21.52	70.0	9.000	L1	ON	20

Remark: Correct factor=cable loss + LISN factor

L line Conducted Emission from 150 KHz to 30 MHz

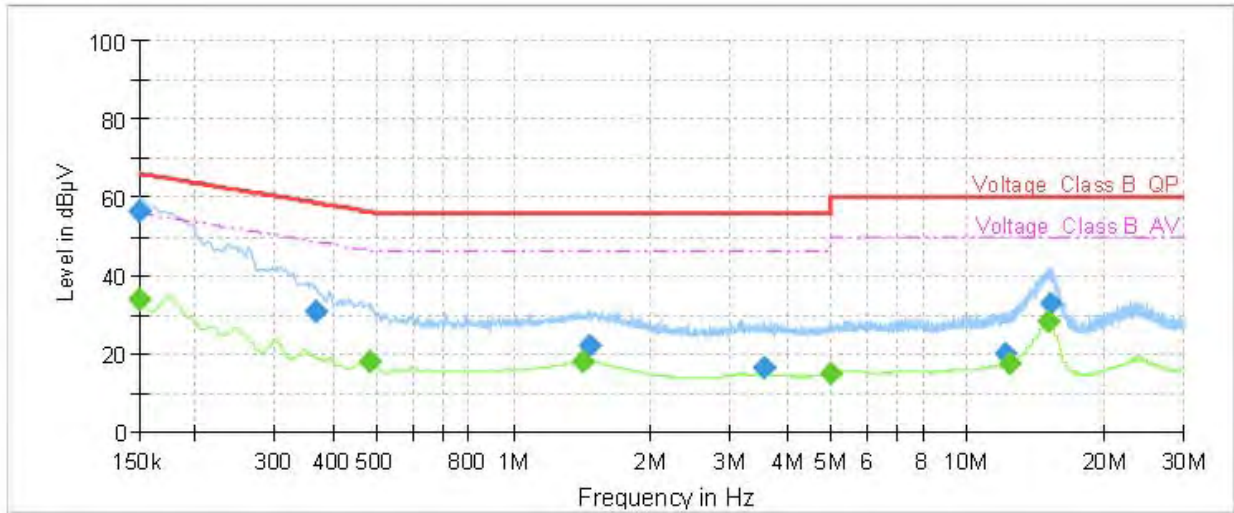

Frequency (MHz)	QuasiPeak (dBµV)	Average (dBµV)	Limit (dBµV)	Margin (dB)	Meas. Time (ms)	Bandwidth (kHz)	Line	Filter	Corr. (dB)
0.15	---	33.89	56.00	22.11	70.0	9.000	N	ON	21
0.15	56.56	---	66.00	9.44	70.0	9.000	N	ON	21
0.37	30.59	---	58.59	28.00	70.0	9.000	N	ON	21
0.48	---	18.06	46.33	28.27	70.0	9.000	N	ON	20
1.43	---	18.09	46.00	27.91	70.0	9.000	N	ON	20
1.47	22.21	---	56.00	33.79	70.0	9.000	N	ON	20
3.57	16.49	---	56.00	39.51	70.0	9.000	N	ON	19
4.98	---	14.73	46.00	31.27	70.0	9.000	N	ON	19
12.12	19.88	---	60.00	40.12	70.0	9.000	N	ON	20
12.40	---	17.53	50.00	32.47	70.0	9.000	N	ON	20
15.07	---	28.16	50.00	21.84	70.0	9.000	N	ON	20
15.25	32.90	---	60.00	27.11	70.0	9.000	N	ON	20

Remark: Correct factor=cable loss + LISN factor

N line Conducted Emission from 150 KHz to 30 MHz



6. Main Test Instruments

Name	Manufacturer	Type	Serial Number	Calibration Date	Expiration Date
Spectrum Analyzer	R&S	FSV40	15195-01-00	2020-05-18	2021-05-17
EMI Test Receiver	R&S	ESCI	100948	2020-05-18	2021-05-17
Loop Antenna	SCHWARZBECK	FMZB1519	1519-047	2020-04-02	2023-04-01
TRILOG Broadband Antenna	SCHWARZBECK	VULB 9163	391	2019-12-16	2021-12-15
Horn Antenna	R&S	HF907	102723	2018-08-11	2021-08-10
Horn Antenna	ETS-Lindgren	3160-09	00102643	2018-06-20	2021-06-19
Standard Gain Horn	STEATITE	QSH-SL-26-40 -K-15	16779	2019-12-24	2022-12-23
Broadband Horn Antenna	SCHWARZBECK	BBHA 9120D	430	2018-07-07	2021-07-06
EMI Test Receiver	R&S	ESR	101667	2020-05-18	2021-05-17
LISN	R&S	ENV216	101171	2018-12-15	2021-12-14
Spectrum Analyzer	KEYSIGHT	N9020A	MY54420163	2020-05-18	2021-05-17
RF Cable	Agilent	SMA 15cm	0001	2020-12-12	2021-06-11
TEMPERATURE CHAMBER	WEISS	VT4002	582261194500 10	2020-05-18	2021-05-17
WLAN AP	Cisco	Air-AP1262N- A-K9	LDK102073 (FCC ID)	/	/
Power Meter	R&S	NRP2	104306	2020-05-18	2021-05-17
Power Sensor	R&S	NRP-Z21	104799	2020-05-18	2021-05-17
DC Power Supply	GWINSTEK	GPS-3030D	GEP882653	2020-05-18	2021-05-17
Software	R&S	EMC32	9.26.0	/	/

*****END OF REPORT *****



ANNEX A: The EUT Appearance

The EUT Appearance are submitted separately.



ANNEX B: Test Setup Photos

The Test Setup Photos are submitted separately.