



# RF TEST REPORT

**Applicant** ZTE Corporation  
**FCC ID** SRQ-ZM8300G  
**Product** NB-IoT/eMTC Module  
**Model** ZM8300G  
**Report No.** RXA1709-0333RF03R1  
**Issue Date** November 14, 2017

TA Technology (Shanghai) Co., Ltd. tested the above equipment in accordance with the requirements in **FCC CFR47 Part 2 (2017)/ FCC CFR47 Part 27C (2017)**. The test results show that the equipment tested is capable of demonstrating compliance with the requirements as documented in this report.

*Jiang peng Lan*

*Performed by: Jiangpeng Lan*

*Kai Xu*

*Approved by: Kai Xu*

---

**TA Technology (Shanghai) Co., Ltd.**

No.145, Jintang Rd, Tangzhen Industry Park, Pudong Shanghai, China

TEL: +86-021-50791141/2/3

FAX: +86-021-50791141/2/3-8000

## Table of Contents

|          |                                                  |    |
|----------|--------------------------------------------------|----|
| 1        | Test Laboratory.....                             | 4  |
| 1.1      | Notes of the Test Report.....                    | 4  |
| 1.2      | Test facility.....                               | 4  |
| 1.3      | Testing Location.....                            | 5  |
| 2        | General Description of Equipment under Test..... | 6  |
| 3        | Applied Standards.....                           | 7  |
| 4        | Test Configuration.....                          | 8  |
| 5        | Test Information.....                            | 9  |
| 5.1      | RF Power Output.....                             | 9  |
| 5.2      | Effective Isotropic Radiated Power.....          | 11 |
| 5.3      | Occupied Bandwidth.....                          | 15 |
| 5.4      | Band Edge Compliance.....                        | 23 |
| 5.5      | Peak-to-Average Power Ratio (PAPR).....          | 29 |
| 5.6      | Frequency Stability.....                         | 31 |
| 5.7      | Spurious Emissions at Antenna Terminals.....     | 34 |
| 5.8      | Radiates Spurious Emission.....                  | 40 |
| 6        | Main Test Instruments.....                       | 46 |
| ANNEX A: | EUT Appearance and Test Setup.....               | 47 |
| A.1      | EUT Appearance.....                              | 47 |
| A.2      | Test Setup.....                                  | 49 |

## Summary of Measurement Results

| Number                                                                                                                                                          | Test Case                               | Clause in FCC rules         | Verdict |
|-----------------------------------------------------------------------------------------------------------------------------------------------------------------|-----------------------------------------|-----------------------------|---------|
| 1                                                                                                                                                               | RF power output                         | 2.1046                      | PASS    |
| 2                                                                                                                                                               | Effective Isotropic Radiated power      | 27.50(b)(10) /27.50(c)(10)  | PASS    |
| 3                                                                                                                                                               | Occupied Bandwidth                      | 2.1049                      | PASS    |
| 4                                                                                                                                                               | Band Edge Compliance                    | 27.53(g)                    | PASS    |
| 5                                                                                                                                                               | Peak-to-Average Power Ratio             | 27.50(d)/KDB971168 D01(5.7) | PASS    |
| 6                                                                                                                                                               | Frequency Stability                     | 2.1055 / 27.54              | PASS    |
| 7                                                                                                                                                               | Spurious Emissions at Antenna Terminals | 2.1051 /27.53(g) /27.53(f)  | PASS    |
| 8                                                                                                                                                               | Radiates Spurious Emission              | 2.1053 /27.53(g) /27.53(f)  | PASS    |
| Date of Testing: October 13, 2017~ October 30, 2017                                                                                                             |                                         |                             |         |
| Note: PASS: The EUT complies with the essential requirements in the standard.<br>FAIL: The EUT does not comply with the essential requirements in the standard. |                                         |                             |         |

# 1 Test Laboratory

## 1.1 Notes of the Test Report

This report shall not be reproduced in full or partial, without the written approval of **TA technology (shanghai) co., Ltd.** The results documented in this report apply only to the tested sample, under the conditions and modes of operation as described herein .Measurement Uncertainties were not taken into account and are published for informational purposes only. This report is written to support regulatory compliance of the applicable standards stated above. This report must not be used by the client to claim product certification, approval, or endorsement by any government agencies.

## 1.2 Test facility

### **CNAS (accreditation number: L2264)**

TA Technology (Shanghai) Co., Ltd. has obtained the accreditation of China National Accreditation Service for Conformity Assessment (CNAS).

### **FCC (Designation number: CN1179, Test Firm Registration Number: 446626)**

TA Technology (Shanghai) Co., Ltd. has been listed on the US Federal Communications Commission list of test facilities recognized to perform electromagnetic emissions measurements.

### **IC (recognition number is 8510A)**

TA Technology (Shanghai) Co., Ltd. has been listed by industry Canada to perform electromagnetic emission measurement.

### **VCCI (recognition number is C-4595, T-2154, R-4113, G-10766)**

TA Technology (Shanghai) Co., Ltd. has been listed by industry Japan to perform electromagnetic emission measurement.

### **A2LA (Certificate Number: 3857.01)**

TA Technology (Shanghai) Co., Ltd. has been listed by American Association for Laboratory Accreditation to perform electromagnetic emission measurement.

### 1.3 Testing Location

Company: TA Technology (Shanghai) Co., Ltd.  
Address: No.145, Jintang Rd, Tangzhen Industry Park, Pudong Shanghai, China  
City: Shanghai  
Post code: 201201  
Country: P. R. China  
Contact: Xu Kai  
Telephone: +86-021-50791141/2/3  
Fax: +86-021-50791141/2/3-8000  
Website: <http://www.ta-shanghai.com>  
E-mail: [xukai@ta-shanghai.com](mailto:xukai@ta-shanghai.com)

## 2 General Description of Equipment under Test

### Client Information

|                             |                                                                                                                |
|-----------------------------|----------------------------------------------------------------------------------------------------------------|
| <b>Applicant</b>            | ZTE Corporation                                                                                                |
| <b>Applicant address</b>    | ZTE Plaza, Keji Road South, Hi-Tech, Industrial Park, Nanshan District, Shenzhen, Guangdong, 518057, P.R.China |
| <b>Manufacturer</b>         | ZTE Corporation                                                                                                |
| <b>Manufacturer address</b> | ZTE Plaza, Keji Road South, Hi-Tech, Industrial Park, Nanshan District, Shenzhen, Guangdong, 518057, P.R.China |

### General information

| EUT Description                                                      |                                                                                                                                 |           |           |
|----------------------------------------------------------------------|---------------------------------------------------------------------------------------------------------------------------------|-----------|-----------|
| Model:                                                               | ZM8300G                                                                                                                         |           |           |
| IMEI:                                                                | 865199030108496                                                                                                                 |           |           |
| Hardware Version:                                                    | ek8A                                                                                                                            |           |           |
| Software Version:                                                    | EN_ZTE_ZM8300GV1.0.0B01                                                                                                         |           |           |
| Power Supply:                                                        | External power supply                                                                                                           |           |           |
| Antenna Type:                                                        | The EUT don't have standard Antenna, The Antenna used for testing in this report is the after-market accessory (Dipole Antenna) |           |           |
| Test Mode(s):                                                        | NB-IOT Band 12, NB-IOT Band 13;                                                                                                 |           |           |
| Test Modulation:                                                     | BPSK, QPSK                                                                                                                      |           |           |
| Category                                                             | NB1                                                                                                                             |           |           |
| Deployment:                                                          | Standalone, in-band, guard-band                                                                                                 |           |           |
| Sub-carrier spacing:                                                 | 3.75KHz, 15KHz                                                                                                                  |           |           |
| Ntones:                                                              | single, multi-tone                                                                                                              |           |           |
| Maximum E.R.P.                                                       | NB-IOT Band 12:                                                                                                                 | 23.51dBm  |           |
|                                                                      | NB-IOT Band 13:                                                                                                                 | 23.54dBm  |           |
| Rated Power Supply Voltage:                                          | 3.6V                                                                                                                            |           |           |
| Extreme Voltage:                                                     | Minimum: 3.0V    Maximum: 4.2V                                                                                                  |           |           |
| Extreme Temperature:                                                 | Lowest: -40°C    Highest: +85°C                                                                                                 |           |           |
| Operating Frequency Range(s)                                         | Mode                                                                                                                            | Tx (MHz)  | Rx (MHz)  |
|                                                                      | NB-IOT Band 12                                                                                                                  | 699 ~ 716 | 729 ~ 746 |
|                                                                      | NB-IOT Band 13                                                                                                                  | 777 ~ 787 | 746 ~ 756 |
| Note: 1. The information of the EUT is declared by the manufacturer. |                                                                                                                                 |           |           |

### **3 Applied Standards**

According to the specifications of the manufacturer, it must comply with the requirements of the following standards:

#### **Test standards**

**FCC CFR47 Part 2 (2017)**

**FCC CFR47 Part 27C (2017)**

**ANSI/TIA-603-D (2010)**

**KDB 971168 D01 Power Meas License Digital Systems v03**

## 4 Test Configuration

Radiated measurements are performed by rotating the EUT in three different orthogonal test planes. EUT stand-up position (Z axis), lie-down position (X, Y axis). Receiver antenna polarization (horizontal and vertical), the worst emission was found in position (X axis, horizontal polarization) and the worst case was recorded.

All mode and data rates and positions and RB size and modulations were investigated. Subsequently, only the worst case emissions are reported.

The following testing in NB-IOT is set based on the maximum RF Output Power.

The following testing in different Bandwidth is set to detail in the following table:

Test modes are chosen to be reported as the worst case configuration below for NB-IOT Band 12/13:

| Test items                                                                                                                                           | Modes      | Deployment mode | Subcarrier Spacing (kHz) |    | Modulation |      | Test Channel |   |   |
|------------------------------------------------------------------------------------------------------------------------------------------------------|------------|-----------------|--------------------------|----|------------|------|--------------|---|---|
|                                                                                                                                                      |            | Stand-alone     | 3.75                     | 15 | BPSK       | QPSK | L            | M | H |
| RF power output                                                                                                                                      | NB-IOT B12 | O               | O                        | O  | O          | O    | O            | O | O |
|                                                                                                                                                      | NB-IOT B13 | O               | O                        | O  | O          | O    | O            | O | O |
| Effective Isotropic Radiated power                                                                                                                   | NB-IOT B12 | O               | O                        | O  | O          | O    | O            | O | O |
|                                                                                                                                                      | NB-IOT B13 | O               | O                        | O  | O          | O    | O            | O | O |
| Occupied Bandwidth                                                                                                                                   | NB-IOT B12 | O               | O                        | O  | O          | O    | O            | O | O |
|                                                                                                                                                      | NB-IOT B13 | O               | O                        | O  | O          | O    | O            | O | O |
| Band Edge Compliance                                                                                                                                 | NB-IOT B12 | O               | O                        | O  | O          | O    | O            | - | O |
|                                                                                                                                                      | NB-IOT B13 | O               | O                        | O  | O          | O    | O            | - | O |
| Peak-to-Average Power Ratio                                                                                                                          | NB-IOT B12 | O               | O                        | O  | O          | O    | -            | O | - |
|                                                                                                                                                      | NB-IOT B13 | O               | O                        | O  | O          | O    | -            | O | - |
| Frequency Stability                                                                                                                                  | NB-IOT B12 | O               | O                        | O  | O          | O    | -            | O | - |
|                                                                                                                                                      | NB-IOT B13 | O               | O                        | O  | O          | O    | -            | O | - |
| Spurious Emissions at Antenna Terminals                                                                                                              | NB-IOT B12 | O               | -                        | O  | -          | O    | O            | O | O |
|                                                                                                                                                      | NB-IOT B13 | O               | -                        | O  | -          | O    | O            | O | O |
| Radiates Spurious Emission                                                                                                                           | NB-IOT B12 | O               | -                        | O  | -          | O    | O            | O | O |
|                                                                                                                                                      | NB-IOT B13 | O               | -                        | O  | -          | O    | O            | O | O |
| <b>Note</b><br>1. The mark "O" means that this configuration is chosen for testing.<br>2. The mark "-" means that this configuration is not testing. |            |                 |                          |    |            |      |              |   |   |



## 5 Test Information

### 5.1 RF Power Output

#### Ambient condition

| Temperature | Relative humidity | Pressure |
|-------------|-------------------|----------|
| 23°C ~25°C  | 45%~50%           | 101.5kPa |

#### Methods of Measurement

During the process of the testing, The EUT is controlled by the Base Station Simulator to ensure max power transmission and proper modulation.

#### Test Setup

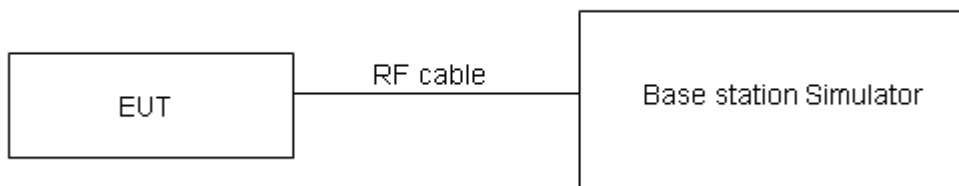

The loss between RF output port of the EUT and the input port of the tester has been taken into consideration.

#### Limits

No specific RF power output requirements in part 2.1046.

#### Measurement Uncertainty

The assessed measurement uncertainty to ensure 95% confidence level for the normal distribution is with the coverage factor  $k = 2$ ,  $U=0.4$  dB.

**Test Results**

| Mode               | Modulation | Sub-carrier spacing (KHz) | Ntones | Conducted Power (dBm)<br>Low/mid/high channel |             |             |
|--------------------|------------|---------------------------|--------|-----------------------------------------------|-------------|-------------|
|                    |            |                           |        | 23011/699.1                                   | 23095/707.5 | 23179/715.9 |
| Band 12 Standalone | BPSK       | 3.75                      | 1@0    | 23.80                                         | 23.60       | 23.66       |
|                    |            |                           | 1@47   | 23.65                                         | 23.55       | 23.62       |
|                    |            | 15                        | 1@0    | 23.94                                         | 23.85       | 23.92       |
|                    |            |                           | 1@11   | 23.91                                         | 23.81       | 23.95       |
|                    | QPSK       | 3.75                      | 1@0    | 23.75                                         | 23.58       | 23.71       |
|                    |            |                           | 1@47   | 23.68                                         | 23.59       | 23.70       |
|                    |            | 15                        | 1@0    | 23.94                                         | 23.84       | 23.93       |
|                    |            |                           | 1@11   | 23.97                                         | 23.88       | 23.97       |
|                    |            | 15                        | 12@0   | 22.10                                         | 22.09       | 22.19       |

| Mode               | Modulation | Sub-carrier spacing (KHz) | Ntones | Conducted Power (dBm) for low/mid/high channel |           |             |
|--------------------|------------|---------------------------|--------|------------------------------------------------|-----------|-------------|
|                    |            |                           |        | 23181/777.1                                    | 23230/782 | 23279/786.9 |
| Band 13 Standalone | BPSK       | 3.75                      | 1@0    | 23.54                                          | 23.53     | 23.55       |
|                    |            |                           | 1@47   | 23.50                                          | 23.49     | 23.48       |
|                    |            | 15                        | 1@0    | 23.98                                          | 23.99     | 23.87       |
|                    |            |                           | 1@11   | 23.96                                          | 23.95     | 23.82       |
|                    | QPSK       | 3.75                      | 1@0    | 23.55                                          | 23.53     | 23.50       |
|                    |            |                           | 1@47   | 23.53                                          | 23.52     | 23.46       |
|                    |            | 15                        | 1@0    | 23.96                                          | 23.98     | 23.89       |
|                    |            |                           | 1@11   | 23.95                                          | 23.94     | 23.88       |
|                    |            | 15                        | 12@0   | 22.31                                          | 22.30     | 22.16       |

## 5.2 Effective Isotropic Radiated Power

### Ambient condition

| Temperature | Relative humidity | Pressure |
|-------------|-------------------|----------|
| 23°C ~25°C  | 45%~50%           | 101.5kPa |

### Methods of Measurement

1. The testing follows FCC KDB 971168 v02r02 Section 5.8 and ANSI/TIA-603-D-2010.

a) Connect the equipment as illustrated. Mount the equipment with the manufacturer specified antenna in a vertical orientation on a manufacturer specified mounting surface located on a non-conducting rotating platform of a RF anechoic chamber (preferred) or a standard radiation site.

b) Key the transmitter, then rotate the EUT 360° azimuthally and record spectrum analyzer power level (LVL) measurements at angular increments that are sufficiently small to permit resolution of all peaks. If a standard radiation test site is used, raise and lower the test antenna to obtain a maximum reading at each angular increment. (Note: several batteries may be needed to offset the effect of battery voltage droop, which should not exceed 5% of the manufactured specified battery voltage during transmission).

c) Replace the transmitter under test with a vertically polarized half-wave dipole (or an antenna whose gain is known relative to an ideal half-wave dipole). The center of the antenna should be at the same location as the center of the antenna under test.

d) Connect the antenna to a signal generator with a known output power and record the path loss (in dB) as LOSS. If a standard radiation test site is used, raise and lower the test antenna to obtain a maximum reading.  $LOSS = \text{Generator Output Power (dBm)} - \text{Analyzer reading (dBm)}$

e) Determine the effective radiated output power at each angular position from the readings in steps b) and d) using the following equation:  $ERP \text{ (dBm)} = LVL \text{ (dBm)} + LOSS \text{ (dB)}$

f) The maximum ERP is the maximum value determined in the preceding step.

g) When calculating ERP, in addition to knowing the antenna radiation and matching characteristics, it is necessary to know the loss values of all elements (e.g.transmission line attenuation, mismatches, filters, combiners) interposed between the point where transmitter output power is measured, and the point where power is applied to the antenna. ERP can then be calculated as follows:

$$ERP \text{ (dBm)} = \text{Output Power (dBm)} - \text{Losses (dB)} + \text{Antenna Gain (dBd)}$$

where: dBd refers to gain relative to an ideal dipole.

$$EIRP \text{ (dBm)} = ERP \text{ (dBm)} + 2.15 \text{ (dB.)}$$

**Test setup**

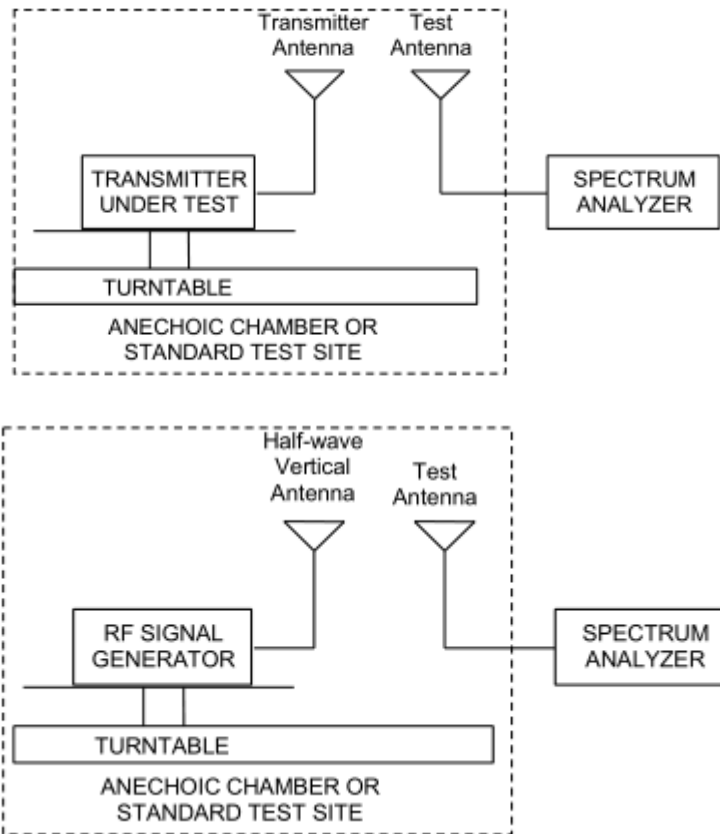

Note: Area side:2.4mX3.6m

The radiated emission was measured in the following position: EUT stand-up position (Z axis), lie-down position (X, Y axis). The worst emission was found in stand-up position (Z axis) and the worst case was recorded.

**Limits**

Rule Part 27.50(b) (10) specifies that “Portable stations (hand-held devices) transmitting in the 746-757 MHz, 776-788 MHz, and 805-806 MHz bands are limited to 3 watts ERP”

Rule Part 27.50(c) (10) specifies that “Portable stations (hand-held devices) in the 600 MHz uplink band and the 698-746 MHz band, and fixed and mobile stations in the 600 MHz uplink band are limited to 3 watts ERP”

|                              |                   |
|------------------------------|-------------------|
| Part 27.50(b)(10)Limit (ERP) | ≤ 3 W (34.77 dBm) |
| Part 27.50(c)(10)Limit (ERP) | ≤ 3 W (34.77 dBm) |

**Measurement Uncertainty**

The assessed measurement uncertainty to ensure 95% confidence level for the normal distribution is with the coverage factor  $k = 2$ ,  $U = 1.19$  dB

**Test Results**

The measurement is performed for both of horizontal and vertical antenna Polarization, and only the data of worst mode is recorded in this report.

| NB-IOT Band 12 |                 |            |              |                           |        |                    |              |                |           |
|----------------|-----------------|------------|--------------|---------------------------|--------|--------------------|--------------|----------------|-----------|
| Channel        | Frequency (MHz) | Modulation | Polarization | Sub-carrier spacing (KHz) | Ntones | Output power (dBm) | Losses (dBm) | Ant gain (dBi) | ERP (dBm) |
| 23011          | 699.1           | BPSK       | H            | 3.75                      | 1@0    | -27.41             | -47.92       | 2.06           | 22.57     |
|                |                 | QPSK       | H            | 3.75                      | 1@0    | -27.37             | -47.92       | 2.06           | 22.61     |
|                |                 | BPSK       | H            | 15                        | 1@0    | -26.40             | -47.85       | 2.06           | 23.51     |
|                |                 | QPSK       | H            | 15                        | 1@0    | -26.56             | -47.85       | 2.06           | 23.35     |
| 23095          | 707.5           | BPSK       | H            | 3.75                      | 1@0    | -28.14             | -48.27       | 2.03           | 22.16     |
|                |                 | QPSK       | H            | 3.75                      | 1@0    | -28.04             | -48.27       | 2.03           | 22.25     |
|                |                 | BPSK       | H            | 15                        | 1@0    | -27.23             | -48.26       | 2.03           | 23.06     |
|                |                 | QPSK       | H            | 15                        | 1@0    | -27.13             | -48.26       | 2.03           | 23.16     |
| 23179          | 715.9           | BPSK       | H            | 3.75                      | 1@0    | -28.35             | -48.68       | 1.96           | 22.28     |
|                |                 | QPSK       | H            | 3.75                      | 1@0    | -28.26             | -48.68       | 1.96           | 22.38     |
|                |                 | BPSK       | H            | 15                        | 1@0    | -27.44             | -48.66       | 1.96           | 23.18     |
|                |                 | QPSK       | H            | 15                        | 1@0    | -27.34             | -48.66       | 1.96           | 23.29     |

| NB-IOT Band 13 |                 |            |              |                           |        |                    |              |                |           |
|----------------|-----------------|------------|--------------|---------------------------|--------|--------------------|--------------|----------------|-----------|
| Channel        | Frequency (MHz) | Modulation | Polarization | Sub-carrier spacing (KHz) | Ntones | Output power (dBm) | Losses (dBm) | Ant gain (dBi) | ERP (dBm) |
| 23181          | 777.1           | BPSK       | H            | 3.75                      | 1@0    | -29.65             | -50.88       | 1.37           | 22.60     |
|                |                 | QPSK       | H            | 3.75                      | 1@0    | -29.61             | -50.88       | 1.37           | 22.64     |
|                |                 | BPSK       | H            | 15                        | 1@0    | -29.05             | -51.22       | 1.37           | 23.54     |
|                |                 | QPSK       | H            | 15                        | 1@0    | -29.22             | -51.22       | 1.37           | 23.38     |
| 23230          | 782             | BPSK       | H            | 3.75                      | 1@0    | -29.82             | -50.66       | 1.34           | 22.18     |
|                |                 | QPSK       | H            | 3.75                      | 1@0    | -29.73             | -50.66       | 1.34           | 22.28     |
|                |                 | BPSK       | H            | 15                        | 1@0    | -29.15             | -50.89       | 1.34           | 23.08     |
|                |                 | QPSK       | H            | 15                        | 1@0    | -29.05             | -50.89       | 1.34           | 23.19     |
| 23279          | 786.9           | BPSK       | H            | 3.75                      | 1@0    | -29.27             | -50.27       | 1.31           | 22.31     |
|                |                 | QPSK       | H            | 3.75                      | 1@0    | -29.17             | -50.27       | 1.31           | 22.41     |
|                |                 | BPSK       | H            | 15                        | 1@0    | -28.55             | -50.45       | 1.31           | 23.21     |
|                |                 | QPSK       | H            | 15                        | 1@0    | -28.45             | -50.45       | 1.31           | 23.32     |

Note: 1. EIRP= E.R.P+2.15

### 5.3 Occupied Bandwidth

#### Ambient condition

|             |                   |          |
|-------------|-------------------|----------|
| Temperature | Relative humidity | Pressure |
| 23°C ~25°C  | 45%~50%           | 101.5kPa |

#### Method of Measurement

The EUT was connected to Spectrum Analyzer and Base Station Simulator via power Splitter. The occupied bandwidth is measured using spectrum analyzer.

RBW is set to 2kHz, VBW is set to 6.2kHz for NB-IOT Band 12/13.

99% power and -26dBc occupied bandwidths are recorded. Spectrum analyzer plots are included on the following pages.

#### Test Setup

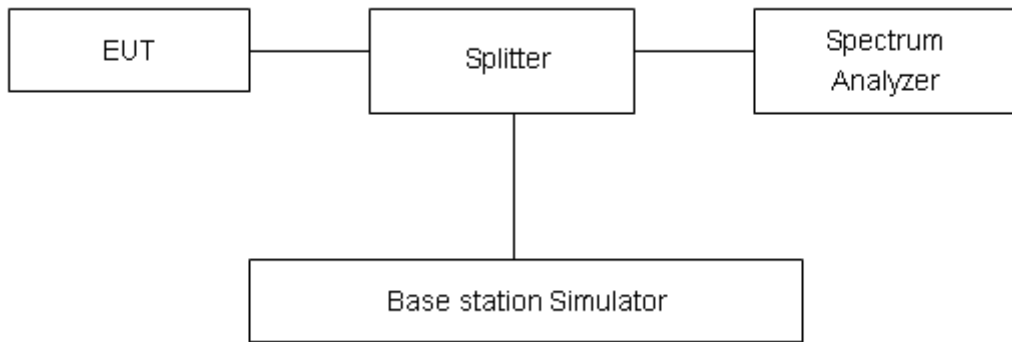

#### Limits

No specific occupied bandwidth requirements in part 2.1049.

#### Measurement Uncertainty

The assessed measurement uncertainty to ensure 95% confidence level for the normal distribution is with the coverage factor  $k = 2$ ,  $U=624\text{Hz}$ .

**Test Result**

| Mode               | Modulation | Sub-carrier spacing (KHz) | Ntones | Bandwidth(KHz) for low/mid/high channel |        |             |        |             |        |
|--------------------|------------|---------------------------|--------|-----------------------------------------|--------|-------------|--------|-------------|--------|
|                    |            |                           |        | 23011/699.1                             |        | 23095/707.5 |        | 23179/715.9 |        |
|                    |            |                           |        | 99% Power                               | -26dBc | 99% Power   | -26dBc | 99% Power   | -26dBc |
| Band 12 Standalone | BPSK       | 3.75                      | 1@0    | 50.088                                  | 38.13  | 46.454      | 36.33  | 47.092      | 37.14  |
|                    | QPSK       | 3.75                      | 1@0    | 57.542                                  | 38.97  | 55.123      | 39.82  | 56.826      | 38.59  |
|                    | BPSK       | 15                        | 1@0    | 128.04                                  | 119.4  | 130.25      | 105    | 126.67      | 104.4  |
|                    | QPSK       | 15                        | 1@0    | 115.93                                  | 115.9  | 119.41      | 128.2  | 117.87      | 118    |
|                    | QPSK       | 15                        | 12@0   | 183.31                                  | 238.3  | 183.79      | 238    | 182.91      | 239.5  |

| Mode               | Modulation | Sub-carrier spacing (KHz) | Ntones | Bandwidth(KHz) for low/mid/high channel |        |           |        |             |        |
|--------------------|------------|---------------------------|--------|-----------------------------------------|--------|-----------|--------|-------------|--------|
|                    |            |                           |        | 23181/777.1                             |        | 23230/782 |        | 23279/786.9 |        |
|                    |            |                           |        | 99% Power                               | -26dBc | 99% Power | -26dBc | 99% Power   | -26dBc |
| Band 13 Standalone | BPSK       | 3.75                      | 1@0    | 46.734                                  | 37.5   | 48.824    | 37.75  | 49.498      | 38.01  |
|                    | QPSK       | 3.75                      | 1@0    | 58.95                                   | 39.63  | 58.048    | 42.21  | 57.558      | 39.72  |
|                    | BPSK       | 15                        | 1@0    | 130.01                                  | 116.9  | 126.22    | 112.2  | 123.14      | 105.4  |
|                    | QPSK       | 15                        | 1@0    | 117.94                                  | 116.9  | 119.13    | 117.5  | 118.91      | 131.6  |
|                    | QPSK       | 15                        | 12@0   | 183.27                                  | 238.7  | 183.28    | 239.4  | 182.66      | 237.9  |





### NB-IOT Band 12 BPSK 3.75KHz 1@0 CH-Low

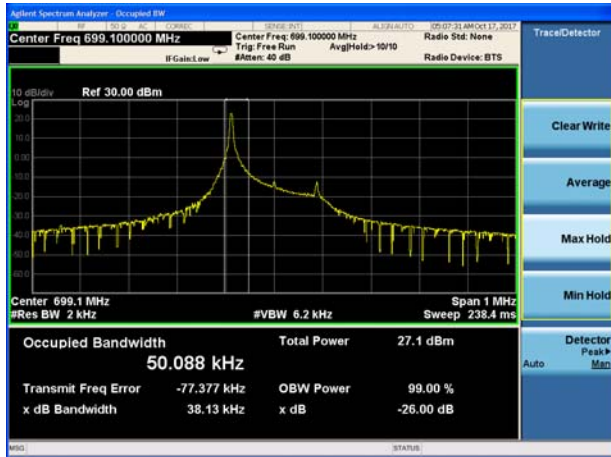

### NB-IOT Band 12 BPSK 15KHz 1@0 CH-Low



### NB-IOT Band 12 BPSK 3.75KHz 1@0 CH-Middle

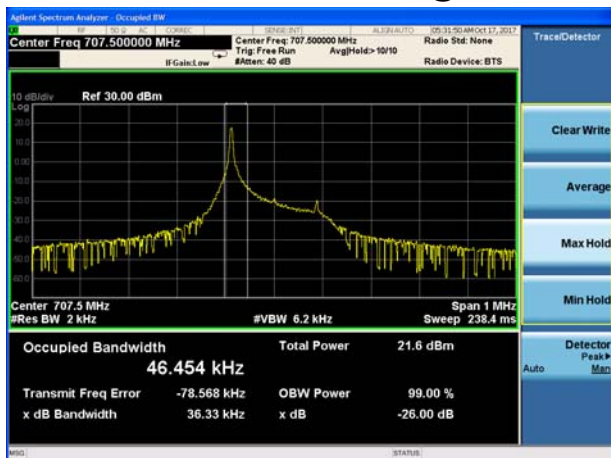

### NB-IOT Band 12 BPSK 15KHz 1@0 CH-Middle



### NB-IOT Band 12 BPSK 3.75KHz 1@0 CH-High

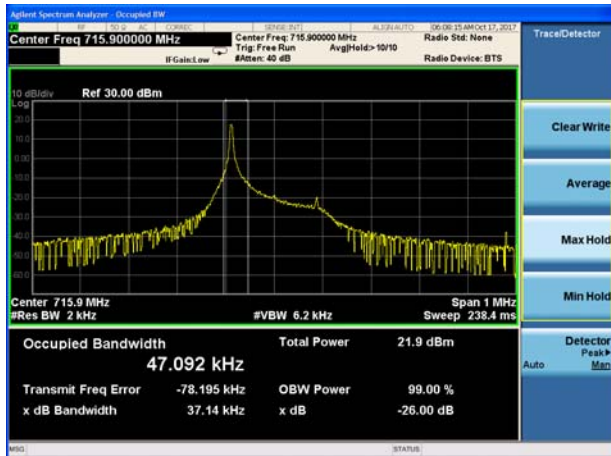

### NB-IOT Band 12 BPSK 15KHz 1@0 CH-High

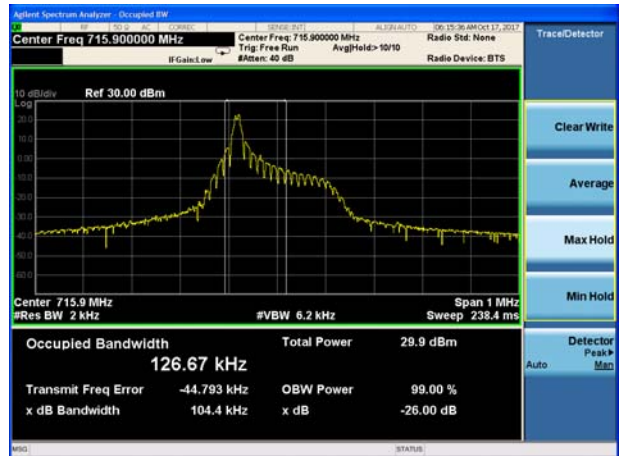

NB-IOT Band 12 QPSK 3.75KMHz 1@0 CH-Low

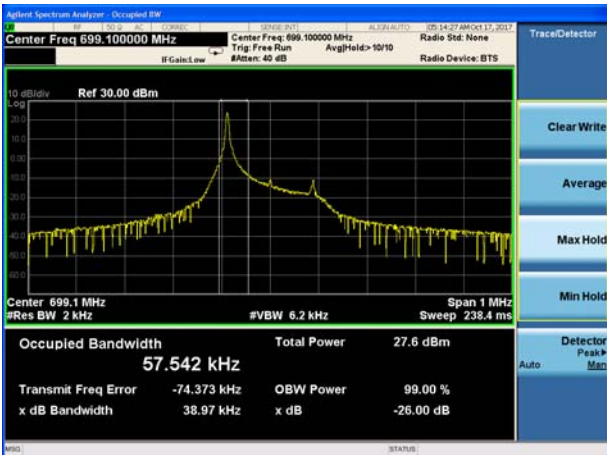

NB-IOT Band 12 QPSK 15KHz 1@0 CH-Low



NB-IOT Band 12 QPSK 3.75KHz 1@0 CH-Middle

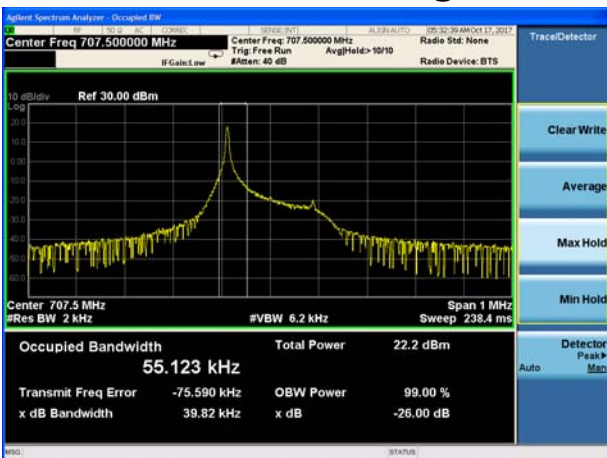

NB-IOT Band 12 QPSK 15KHz 1@0 CH-Middle

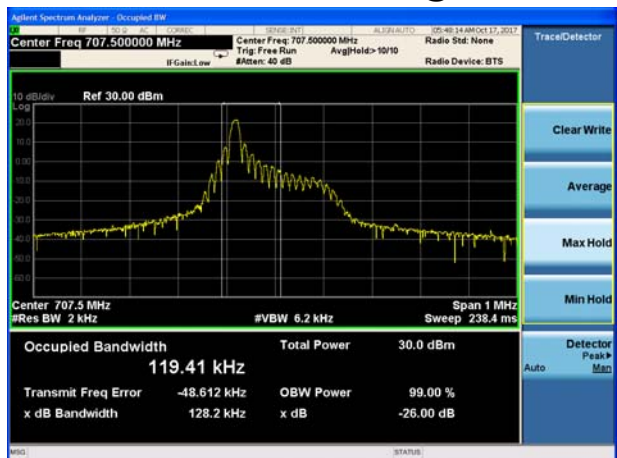

NB-IOT Band 12 QPSK 3.75KMHz 1@0 CH-High

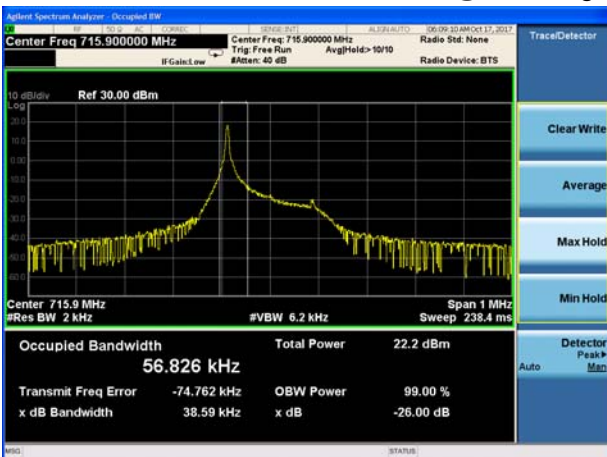

NB-IOT Band 12 QPSK 15KHz 1@0 CH-High

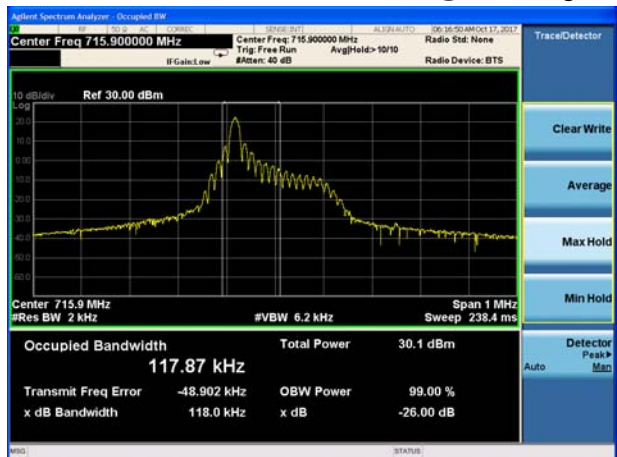

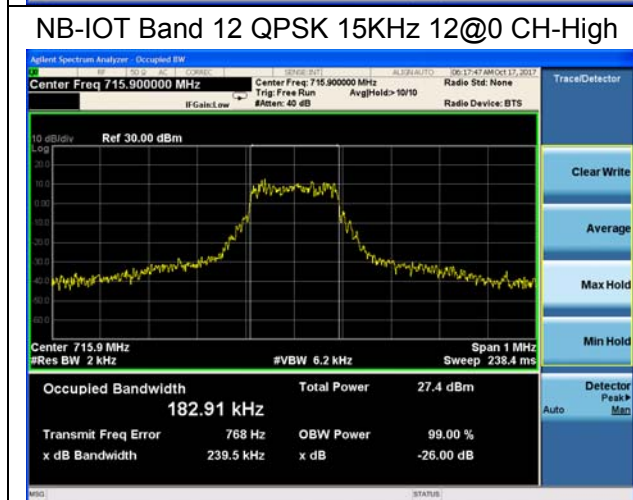
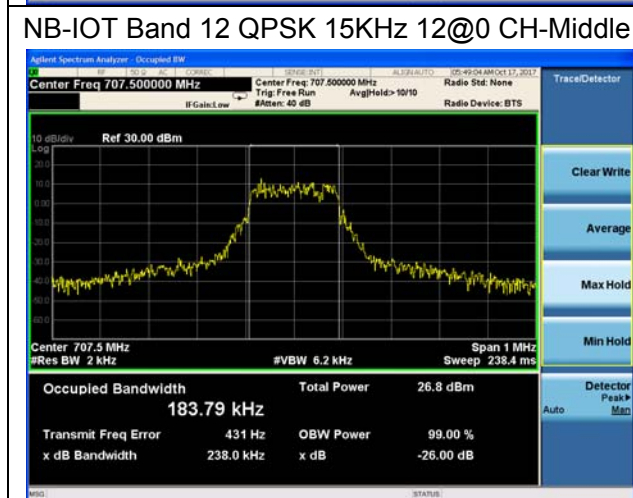
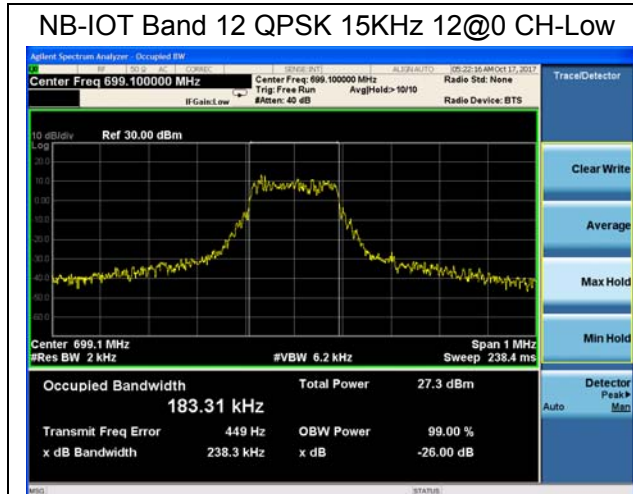

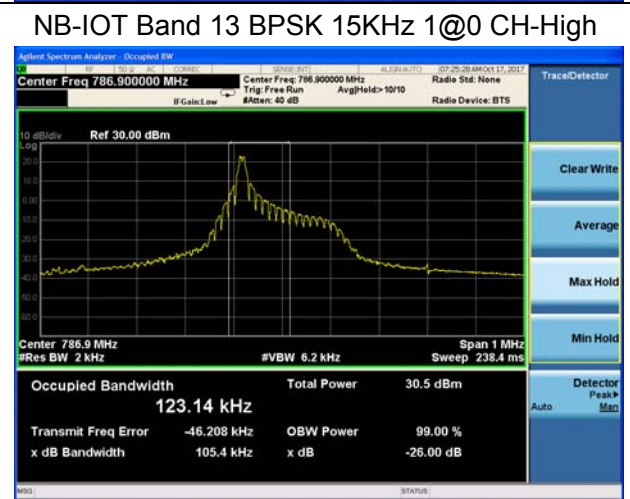
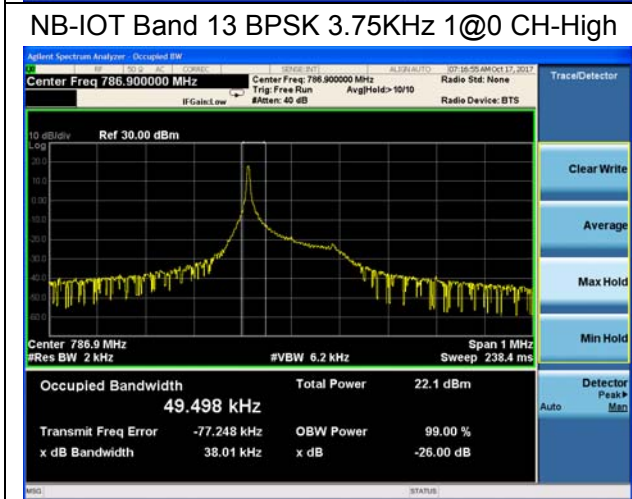
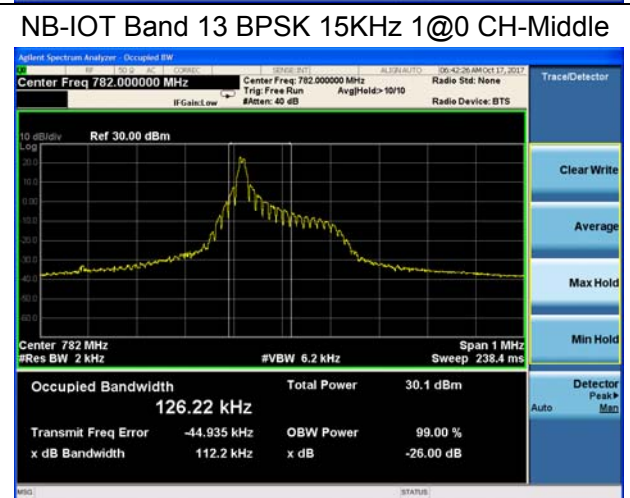
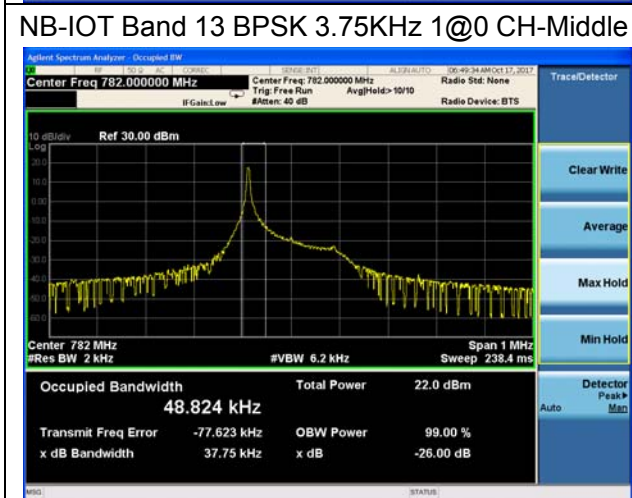
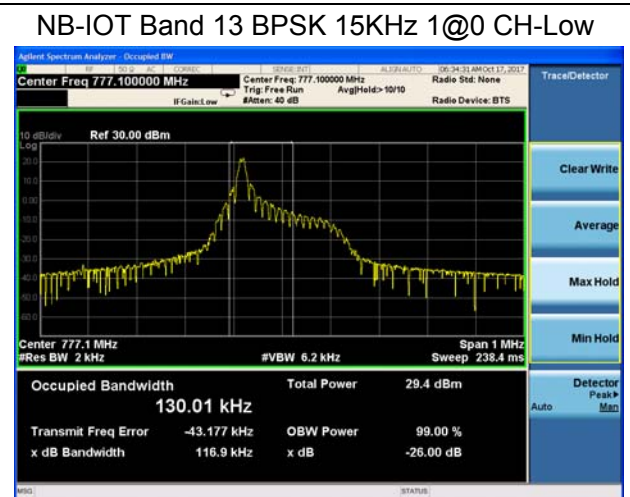
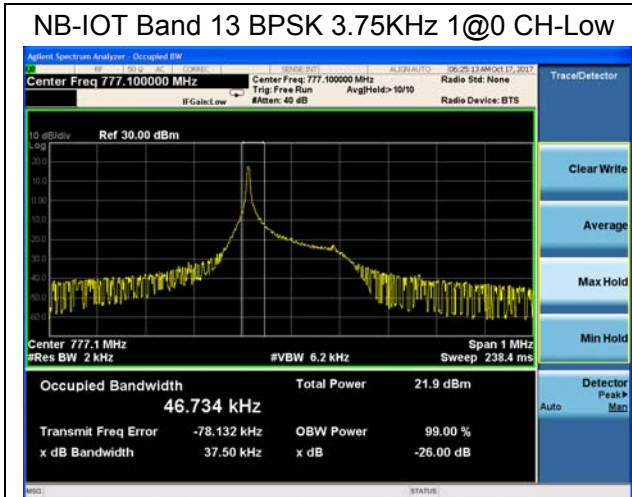



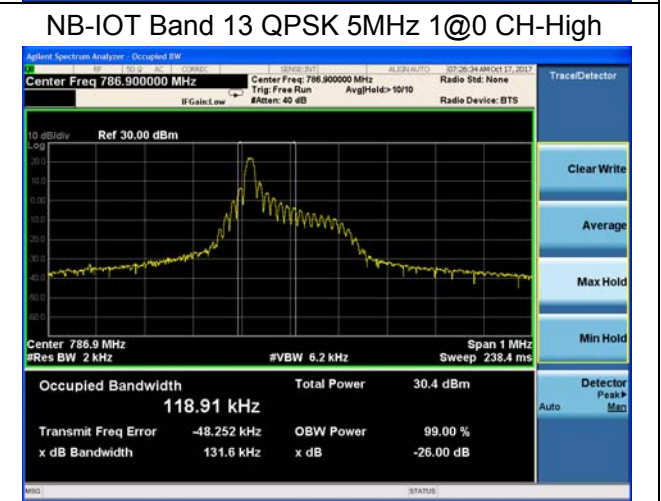
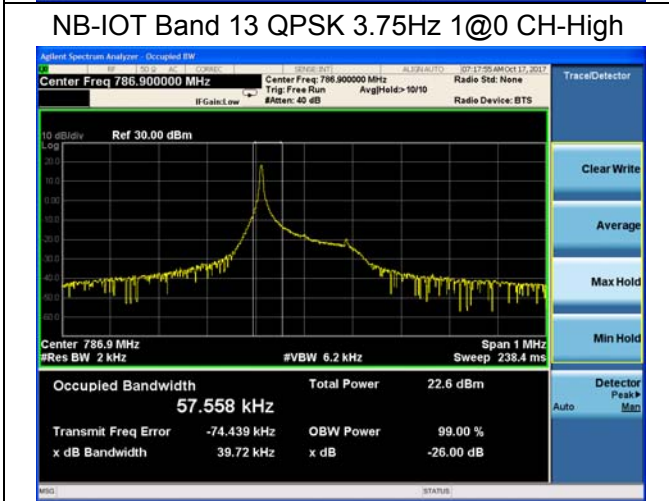
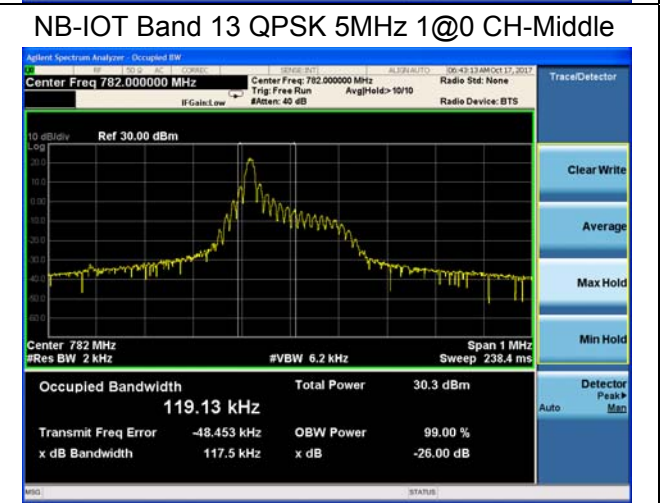
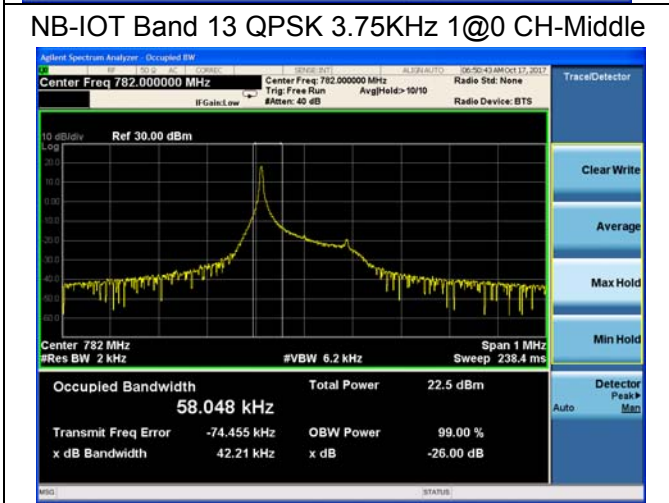
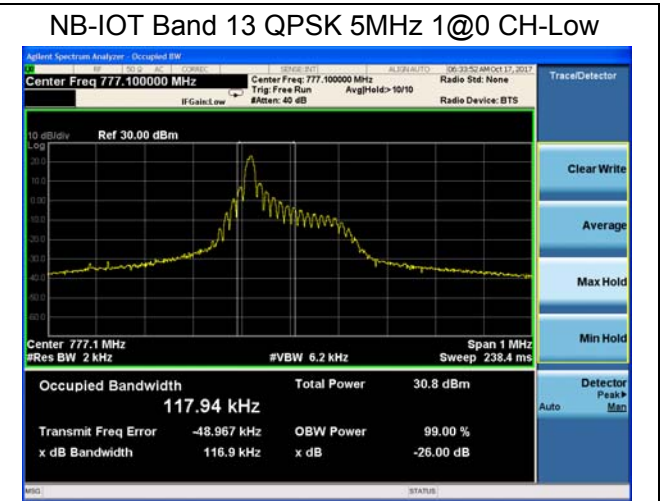
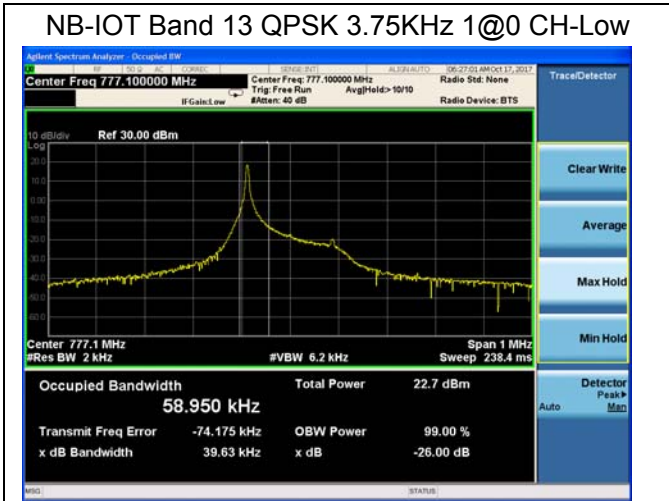

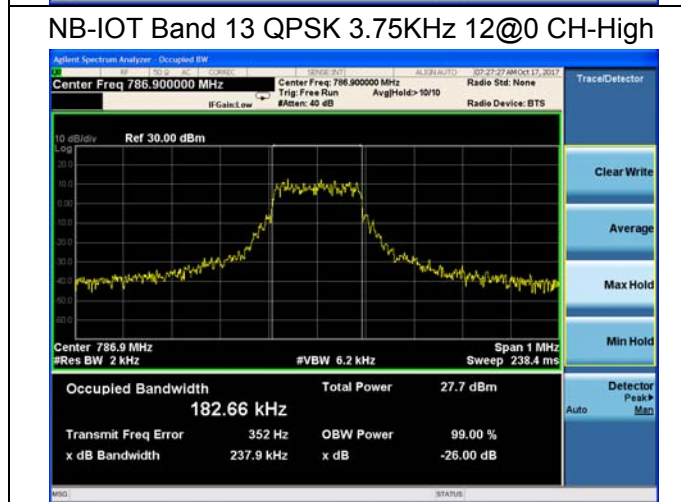
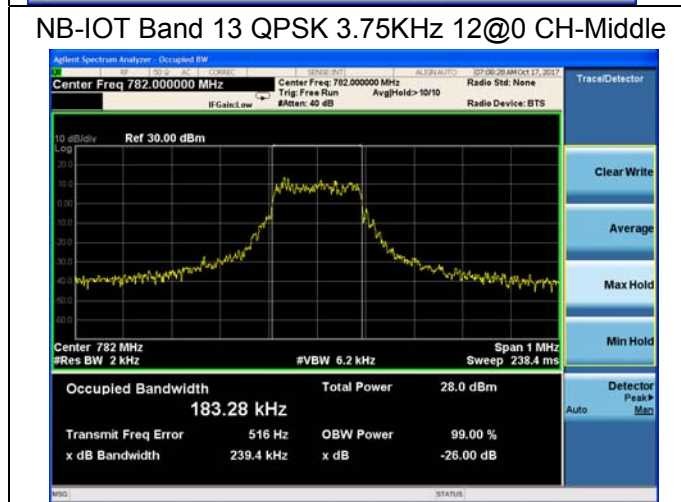
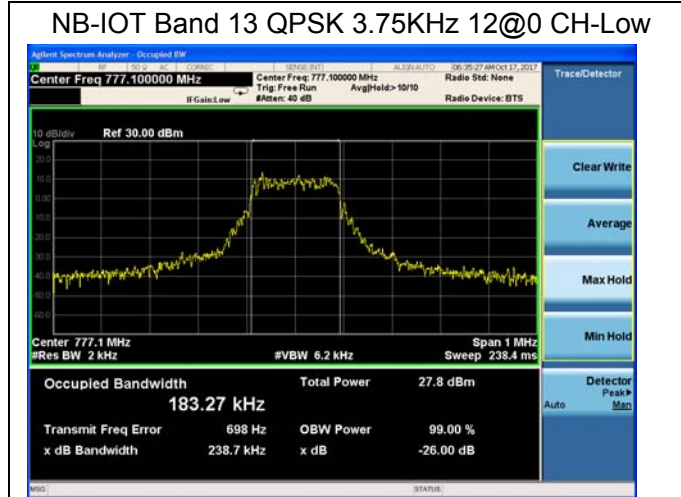

### 5.4 Band Edge Compliance

#### Ambient condition

| Temperature | Relative humidity | Pressure |
|-------------|-------------------|----------|
| 23°C ~25°C  | 45%~50%           | 101.5kPa |

#### Method of Measurement

The EUT was connected to Spectrum Analyzer and Base Station Simulator via power Splitter. The band edge of the lowest and highest channels were measured.

The testing follows KDB 971168 v02r02 Section 6.0

- 1.The EUT was connected to spectrum analyzer and system simulator via a power divider.
2. The band edges of low and high channels for the highest RF powers were measured.
3. RBW is set to 51Hz, VBW is set to 160Hz for 3.75KHz single carrier,  
RBW is set to 200Hz, VBW is set to 620Hz for 15KHz single carrier,  
RBW is set to 2kHz, VBW is set to 6.2KHz for 15KHz full carrier on spectrum analyzer
4. Set spectrum analyzer with RMS detector.
5. The RF fundamental frequency should be excluded against the limit line in the operating frequency band.
6. Checked that all the results comply with the emission limit line.

#### Test Setup

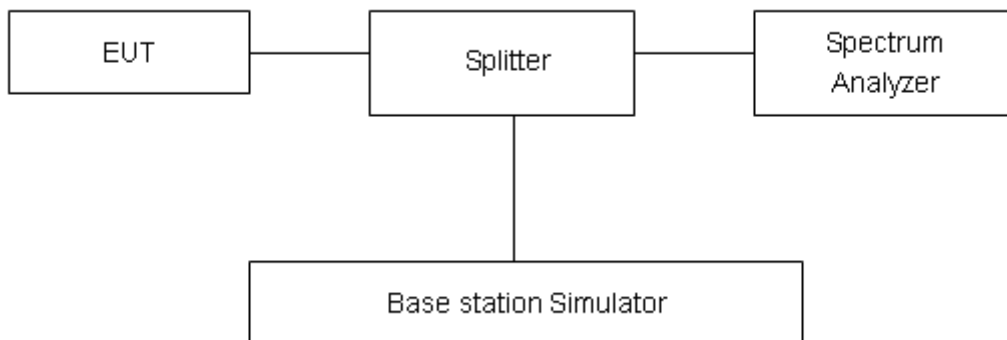



## Limits

Part 27.53(g) specifies that “ For operations in the 600 MHz band and the 698-746 MHz band, the power of any emission outside a licensee's frequency block shall be attenuated below the transmitter power (P) within the licensed band(s) of operation, measured in watts, by at least  $43 + 10 \log_{10} (P)$  dB.”

## Measurement Uncertainty

The assessed measurement uncertainty to ensure 95% confidence level for the normal distribution is with the coverage factor  $k = 1.96$ ,  $U=0.684\text{dB}$ .



**Test Result**

All the test traces in the plots shows the test results clearly.

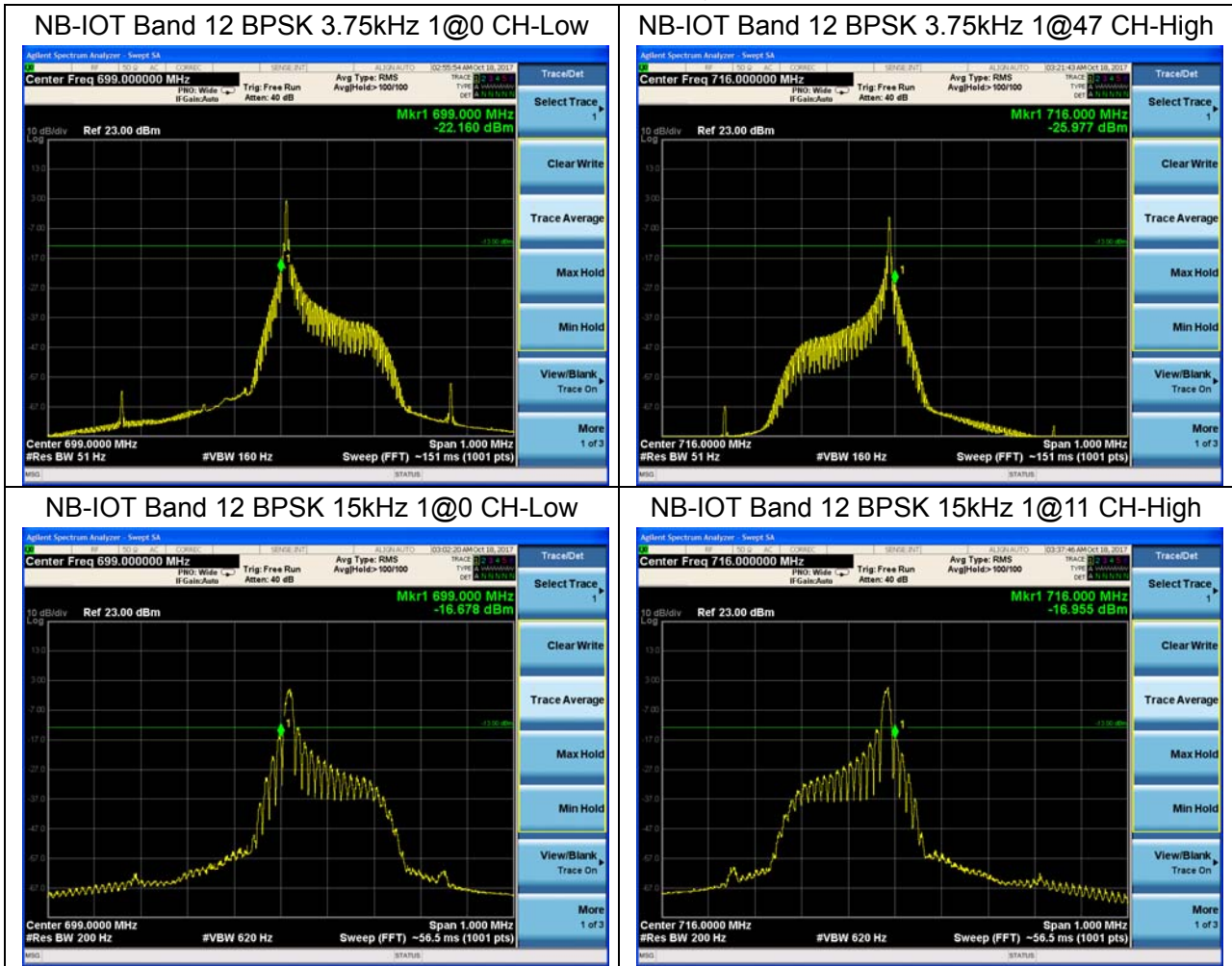

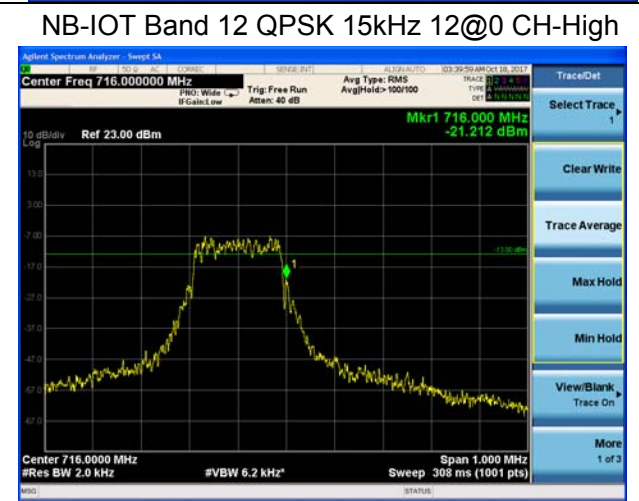
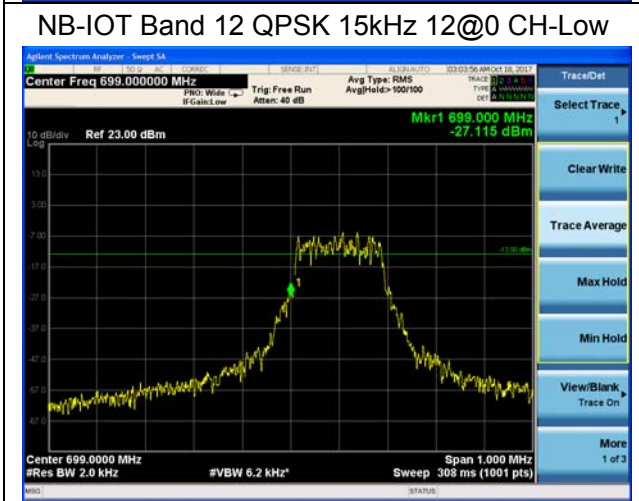
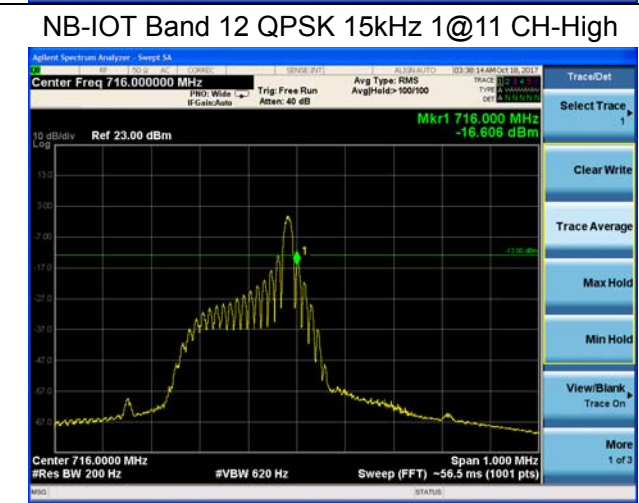
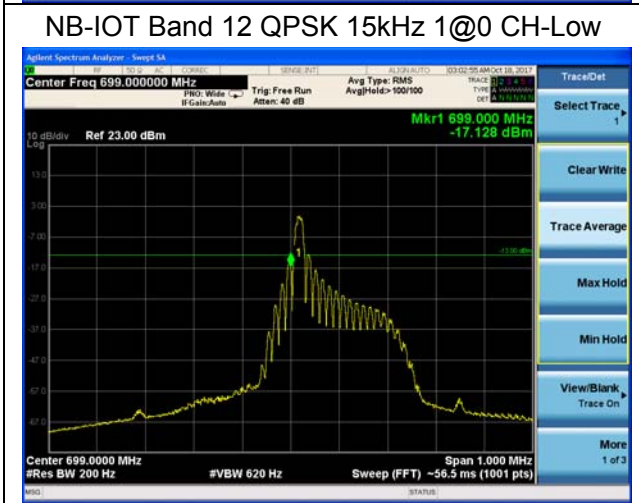
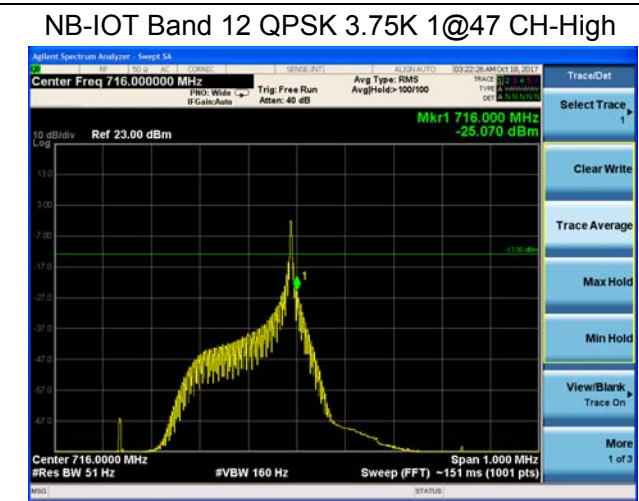
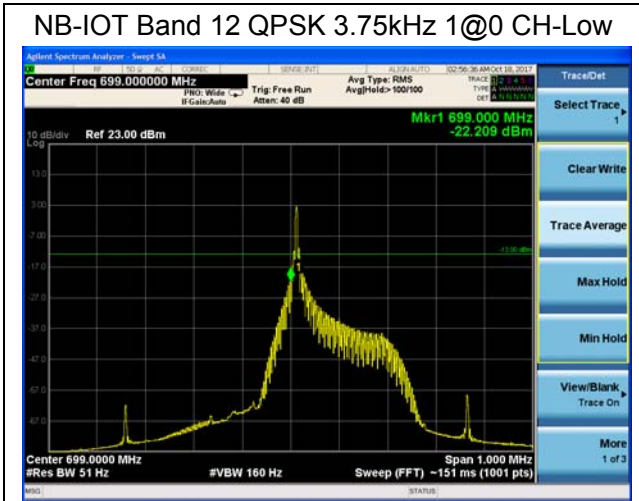

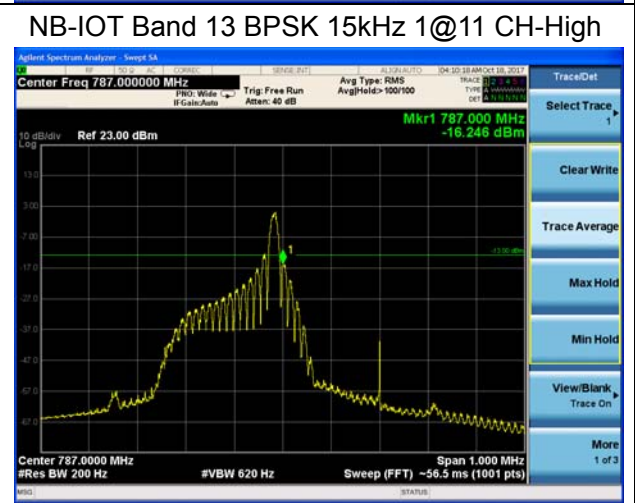
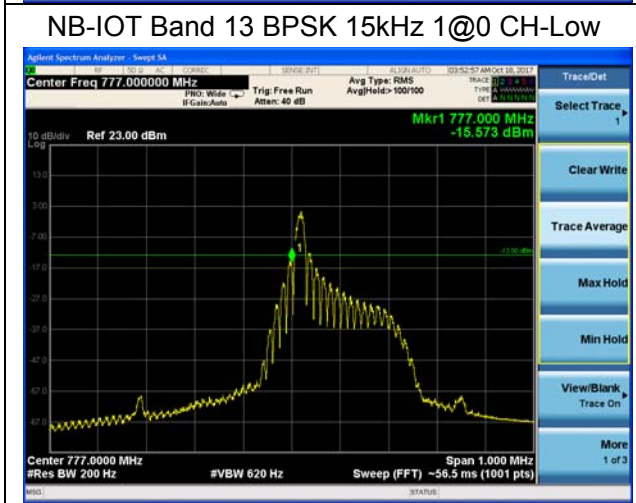
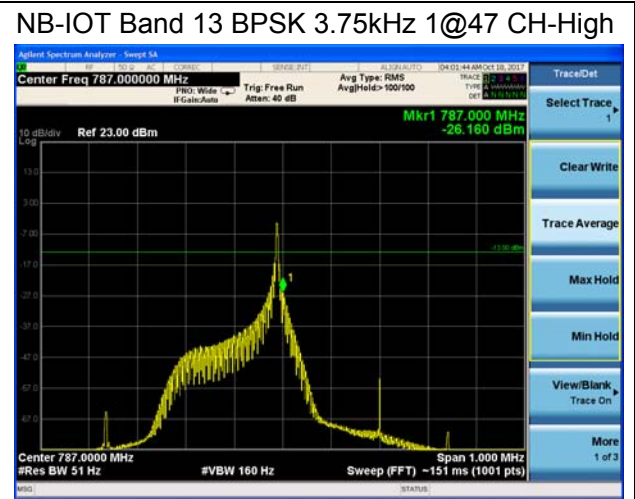
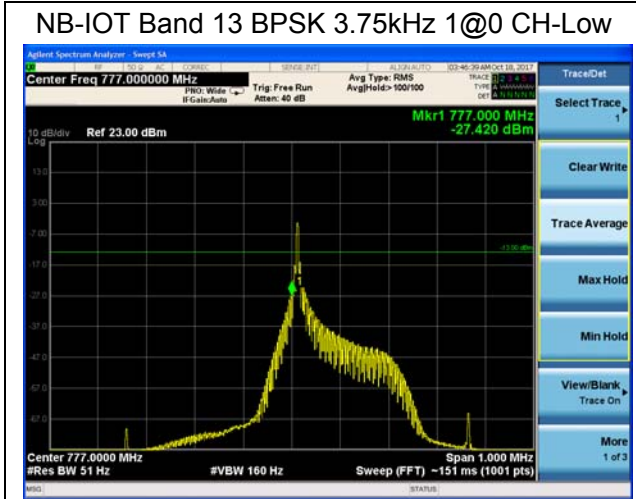

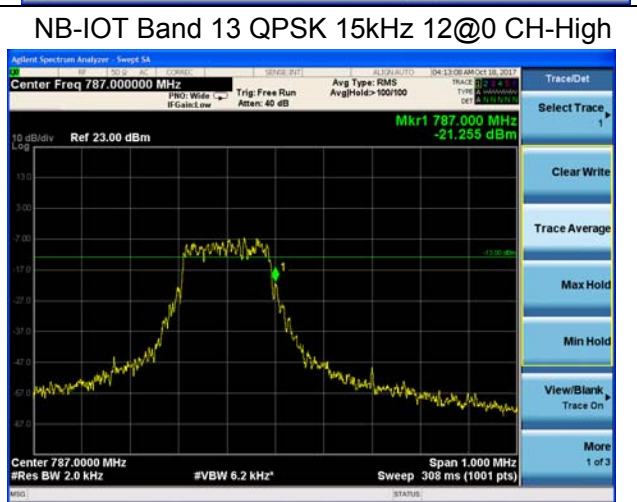
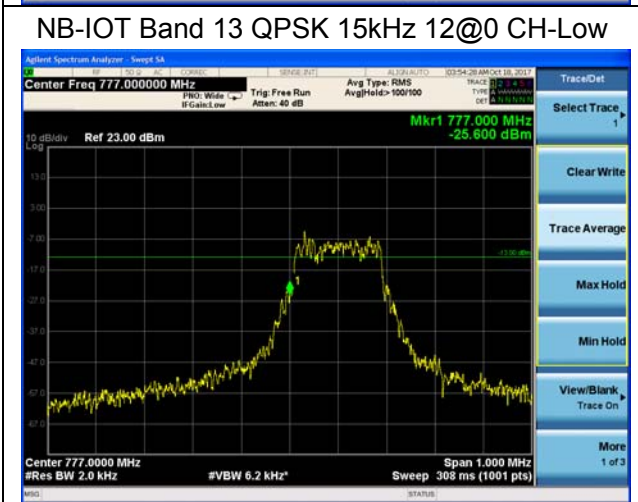
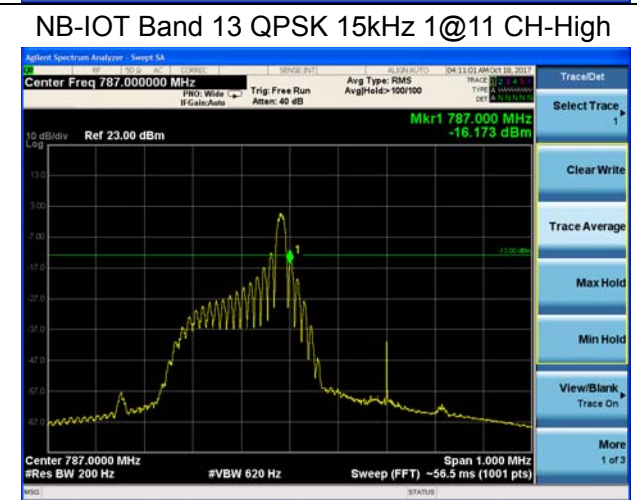
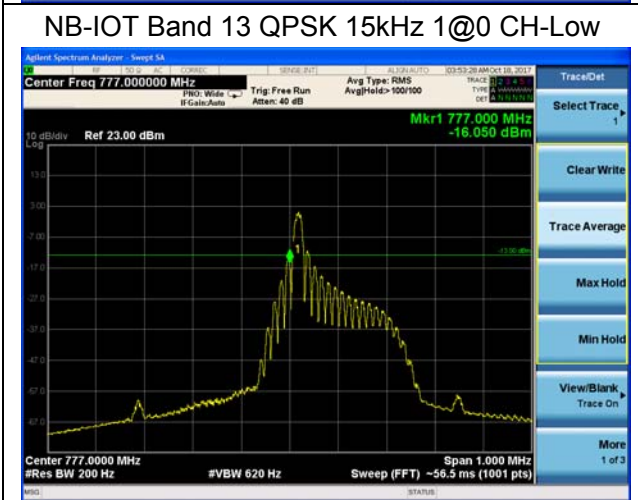
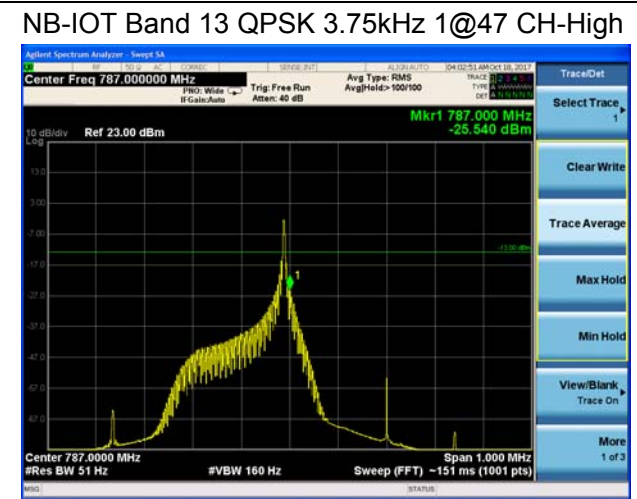
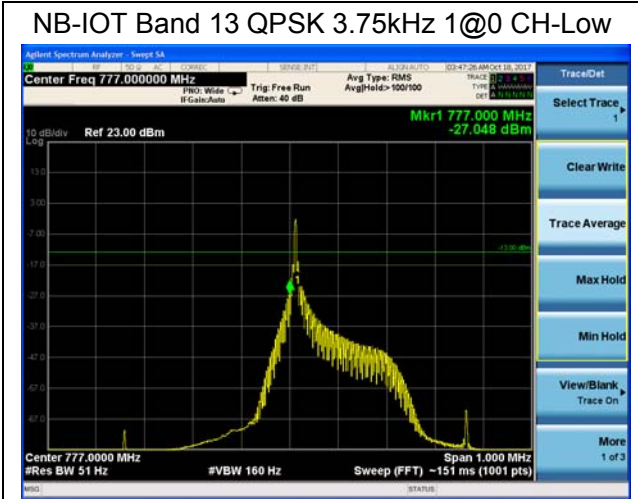

### 5.5 Peak-to-Average Power Ratio (PAPR)

#### Ambient condition

| Temperature | Relative humidity | Pressure |
|-------------|-------------------|----------|
| 23°C ~25°C  | 45%~50%           | 101.5kPa |

#### Methods of Measurement

Measure the total peak power and record as Ppk. And measure the total average power and record as PAvg. Both the peak and average power levels must be expressed in the same logarithmic units (e.g., dBm). Determine the PAPR from:

$$PAPR (dB) = Ppk (dBm) - PAvg (dBm).$$

#### Test Setup

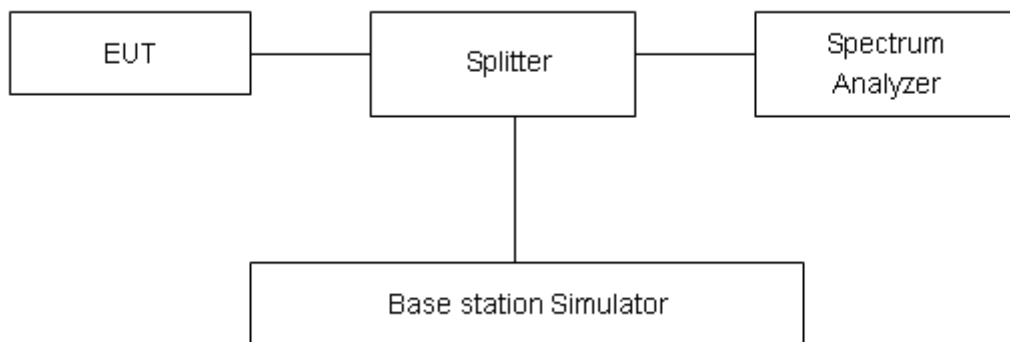

#### Limits

Rule Part 27.50(d)(5) Equipment employed must be authorized in accordance with the provisions of 24.51. Power measurements for transmissions by stations authorized under this section may be made either in accordance with a Commission-approved average power technique or in compliance with paragraph (d)(6) of this section. In measuring transmissions in this band using an average power technique, the peak-to-average ratio (PAR) of the transmission may not exceed 13 dB.

#### Measurement Uncertainty

The assessed measurement uncertainty to ensure 95% confidence level for the normal distribution is with the coverage factor k = 2, U= 0.4 dB.

**Test Results**

| Mode                  | Modulation | Sub-carrier spacing (KHz) | Channel/<br>Frequency(MHz) | Peak-to-Average Power Ratio (PAPR) |          |          |
|-----------------------|------------|---------------------------|----------------------------|------------------------------------|----------|----------|
|                       |            |                           |                            | Peak(dBm)                          | Avg(dBm) | PAPR(dB) |
| Band 12<br>Standalone | BPSK       | 3.75                      | 23095/707.5                | 27.42                              | 23.60    | 3.82     |
|                       | QPSK       | 3.75                      | 23095/707.5                | 27.08                              | 23.58    | 3.50     |
|                       | BPSK       | 15                        | 23095/707.5                | 30.41                              | 23.85    | 6.56     |
|                       | QPSK       | 15                        | 23095/707.5                | 30.35                              | 23.84    | 6.51     |

| Mode                  | Modulation | Sub-carrier spacing (KHz) | Channel/<br>Frequency(MHz) | Peak-to-Average Power Ratio (PAPR) |          |          |
|-----------------------|------------|---------------------------|----------------------------|------------------------------------|----------|----------|
|                       |            |                           |                            | Peak(dBm)                          | Avg(dBm) | PAPR(dB) |
| Band 13<br>Standalone | BPSK       | 3.75                      | 23230/782                  | 27.36                              | 23.53    | 3.83     |
|                       | QPSK       | 3.75                      | 23230/782                  | 27.01                              | 23.53    | 3.48     |
|                       | BPSK       | 15                        | 23230/782                  | 30.45                              | 23.99    | 6.46     |
|                       | QPSK       | 15                        | 23230/782                  | 30.43                              | 23.98    | 6.45     |



## 5.6 Frequency Stability

### Ambient condition

| Temperature | Relative humidity | Pressure |
|-------------|-------------------|----------|
| 23°C ~25°C  | 45%~50%           | 101.5kPa |

### Method of Measurement

#### 1. Frequency Stability (Temperature Variation)

The temperature inside the climate chamber is varied from -40°C to +85°C in 10°C step size.

(1)With all power removed, the temperature was decreased to -10°C and permitted to stabilize for three hours.

(2)Measure the carrier frequency with the test equipment in a “call mode”. These measurements should be made within 1 minute of powering up the mobile station, to prevent significant self warming.

(3) Repeat the above measurements at 10°C increments from -40°C to +85°C. Allow at least 1.5 hours at each temperature, un-powered, before making measurements.

#### 2. Frequency Stability (Voltage Variation)

The frequency stability shall be measured with variation of primary supply voltage as follows:

(1) Vary primary supply voltage from 85 to 115 percent of the nominal value for other than hand carried battery equipment.

(2) For hand carried, battery powered equipment, reduce primary supply voltage to the battery-operating end point which shall be specified by the manufacturer.

This transceiver is specified to operate with an input voltage of between 3.0 V and 4.2 V, with a nominal voltage of 3.6V.

### Test setup

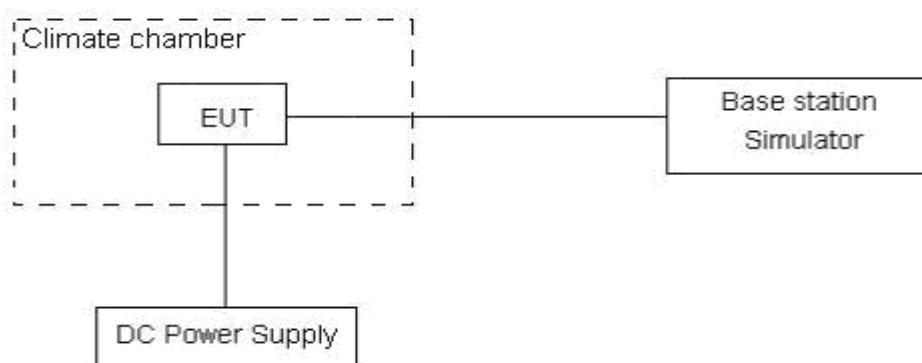

### Limits

No specific frequency stability requirements in part 27.54

### Measurement Uncertainty

The assessed measurement uncertainty to ensure 99.75% confidence level for the normal distribution is with the coverage factor  $k = 3, U=0.01\text{ppm}$ .

**Test Result**

| Mode               | Sub-carrier spacing (KHz) | Channel/<br>Frequency(MHz) | Test status          | Frequency Stability (ppm) |          |         |
|--------------------|---------------------------|----------------------------|----------------------|---------------------------|----------|---------|
|                    |                           |                            |                      | BPSK                      | QPSK     |         |
| Band 12 Standalone | 3.75                      | 23095/707.5                | -40°C/Normal Voltage | -0.00414                  | -0.00220 |         |
|                    |                           | 23095/707.5                | -30°C/Normal Voltage | -0.00222                  | -0.00316 |         |
|                    |                           | 23095/707.5                | -20°C/Normal Voltage | -0.00153                  | 0.00090  |         |
|                    |                           | 23095/707.5                | -10°C/Normal Voltage | -0.00166                  | 0.00072  |         |
|                    |                           | 23095/707.5                | 0°C/Normal Voltage   | -0.00084                  | -0.00092 |         |
|                    |                           | 23095/707.5                | 10°C/Normal Voltage  | -0.00393                  | -0.00410 |         |
|                    |                           | 23095/707.5                | 20°C/Normal Voltage  | -0.00160                  | -0.00311 |         |
|                    |                           | 23095/707.5                | 30°C/Normal Voltage  | 0.00052                   | -0.00348 |         |
|                    |                           | 23095/707.5                | 40°C/Normal Voltage  | -0.00177                  | -0.00207 |         |
|                    |                           | 23095/707.5                | 50°C/Normal Voltage  | -0.00297                  | -0.00040 |         |
|                    |                           | 23095/707.5                | 60°C/Normal Voltage  | 0.00042                   | 0.00087  |         |
|                    |                           | 23095/707.5                | 70°C/Normal Voltage  | -0.00206                  | -0.00292 |         |
|                    |                           | 23095/707.5                | 80°C/Normal Voltage  | -0.00099                  | 0.00091  |         |
|                    |                           | 23095/707.5                | 85°C/Normal Voltage  | 0.00164                   | 0.00121  |         |
|                    |                           | 23095/707.5                | 20°C/Minimum Voltage | -0.00173                  | -0.00193 |         |
|                    | 23095/707.5               | 20°C/Maximum Voltage       | -0.00116             | -0.00162                  |          |         |
|                    |                           | 15                         | 23095/707.5          | -40°C/Normal Voltage      | 0.00193  | 0.00237 |
|                    |                           |                            | 23095/707.5          | -30°C/Normal Voltage      | 0.00078  | 0.00099 |
|                    |                           |                            | 23095/707.5          | -20°C/Normal Voltage      | 0.00210  | 0.00101 |
|                    |                           |                            | 23095/707.5          | -10°C/Normal Voltage      | 0.00146  | 0.00199 |
|                    |                           |                            | 23095/707.5          | 0°C/Normal Voltage        | 0.00071  | 0.00194 |
|                    |                           |                            | 23095/707.5          | 10°C/Normal Voltage       | -0.00149 | 0.00102 |
|                    |                           |                            | 23095/707.5          | 20°C/Normal Voltage       | 0.00106  | 0.00459 |
|                    |                           |                            | 23095/707.5          | 30°C/Normal Voltage       | 0.00132  | 0.00098 |
|                    |                           |                            | 23095/707.5          | 40°C/Normal Voltage       | 0.00218  | 0.00104 |
|                    |                           |                            | 23095/707.5          | 50°C/Normal Voltage       | 0.00025  | 0.00080 |
|                    |                           |                            | 23095/707.5          | 60°C/Normal Voltage       | -0.00097 | 0.00039 |
|                    |                           |                            | 23095/707.5          | 70°C/Normal Voltage       | -0.00155 | 0.00335 |
|                    |                           |                            | 23095/707.5          | 80°C/Normal Voltage       | 0.00131  | 0.00032 |
|                    |                           |                            | 23095/707.5          | 85°C/Normal Voltage       | 0.00183  | 0.00170 |
|                    | 23095/707.5               |                            | 20°C/Minimum Voltage | 0.00213                   | 0.00205  |         |
|                    | 23095/707.5               | 20°C/Maximum Voltage       | 0.00166              | 0.00101                   |          |         |



| Mode                  | Sub-carrier spacing (KHz) | Channel/<br>Frequency(MHz) | Test status          | Frequency Stability (ppm) |          |          |
|-----------------------|---------------------------|----------------------------|----------------------|---------------------------|----------|----------|
|                       |                           |                            |                      | BPSK                      | QPSK     |          |
| Band 13<br>Standalone | 3.75                      | 23230/782                  | -40°C/Normal Voltage | -0.00221                  | -0.00189 |          |
|                       |                           | 23230/782                  | -30°C/Normal Voltage | -0.00407                  | 0.00072  |          |
|                       |                           | 23230/782                  | -20°C/Normal Voltage | -0.00399                  | 0.00137  |          |
|                       |                           | 23230/782                  | -10°C/Normal Voltage | -0.00335                  | 0.00060  |          |
|                       |                           | 23230/782                  | 0°C/Normal Voltage   | -0.00356                  | -0.00123 |          |
|                       |                           | 23230/782                  | 10°C/Normal Voltage  | -0.00349                  | -0.00575 |          |
|                       |                           | 23230/782                  | 20°C/Normal Voltage  | -0.00349                  | -0.00265 |          |
|                       |                           | 23230/782                  | 30°C/Normal Voltage  | -0.00299                  | -0.00232 |          |
|                       |                           | 23230/782                  | 40°C/Normal Voltage  | -0.00377                  | -0.00360 |          |
|                       |                           | 23230/782                  | 50°C/Normal Voltage  | -0.00166                  | -0.00136 |          |
|                       |                           | 23230/782                  | 60°C/Normal Voltage  | -0.00306                  | 0.00038  |          |
|                       |                           | 23230/782                  | 70°C/Normal Voltage  | -0.00258                  | 0.00124  |          |
|                       |                           | 23230/782                  | 80°C/Normal Voltage  | -0.00268                  | 0.00104  |          |
|                       |                           | 23230/782                  | 85°C/Normal Voltage  | -0.00139                  | -0.00037 |          |
|                       |                           | 23230/782                  | 20°C/Minimum Voltage | -0.00029                  | -0.00041 |          |
|                       |                           | 23230/782                  | 20°C/Maximum Voltage | -0.00490                  | 0.00133  |          |
|                       |                           | 15                         | 23230/782            | -40°C/Normal Voltage      | 0.00030  | 0.00196  |
|                       |                           |                            | 23230/782            | -30°C/Normal Voltage      | 0.00059  | 0.00171  |
|                       |                           |                            | 23230/782            | -20°C/Normal Voltage      | 0.00413  | -0.00002 |
|                       |                           |                            | 23230/782            | -10°C/Normal Voltage      | 0.00170  | 0.00219  |
|                       |                           |                            | 23230/782            | 0°C/Normal Voltage        | 0.00010  | -0.00214 |
|                       |                           |                            | 23230/782            | 10°C/Normal Voltage       | 0.00156  | -0.00074 |
|                       |                           |                            | 23230/782            | 20°C/Normal Voltage       | -0.00077 | -0.00398 |
|                       |                           |                            | 23230/782            | 30°C/Normal Voltage       | 0.00045  | 0.00275  |
|                       |                           |                            | 23230/782            | 40°C/Normal Voltage       | -0.00242 | -0.00063 |
|                       |                           |                            | 23230/782            | 50°C/Normal Voltage       | -0.00136 | -0.00034 |
|                       |                           |                            | 23230/782            | 60°C/Normal Voltage       | 0.00011  | 0.00028  |
|                       |                           |                            | 23230/782            | 70°C/Normal Voltage       | 0.00104  | -0.00296 |
|                       | 23230/782                 | 80°C/Normal Voltage        | -0.00106             | -0.00140                  |          |          |
|                       | 23230/782                 | 85°C/Normal Voltage        | -0.00195             | -0.00135                  |          |          |
|                       | 23230/782                 | 20°C/Minimum Voltage       | 0.00284              | -0.00095                  |          |          |
|                       | 23230/782                 | 20°C/Maximum Voltage       | -0.00143             | 0.00099                   |          |          |

### 5.7 Spurious Emissions at Antenna Terminals

**Ambient condition**

| Temperature | Relative humidity | Pressure |
|-------------|-------------------|----------|
| 23°C ~25°C  | 45%~50%           | 101.5kPa |

**Method of Measurement**

The EUT was connected to Spectrum Analyzer and Base Station Simulator via power Splitter. The measurement is carried out using a spectrum analyzer. The spectrum analyzer scans from 30MHz to the 10th harmonic of the carrier. The peak detector is used. Set RBW 1MHz and VBW3MHz, Sweep is set to ATUO.

Of those disturbances below (limit – 20 dB), the mark is not required for the EUT.

**Test setup**

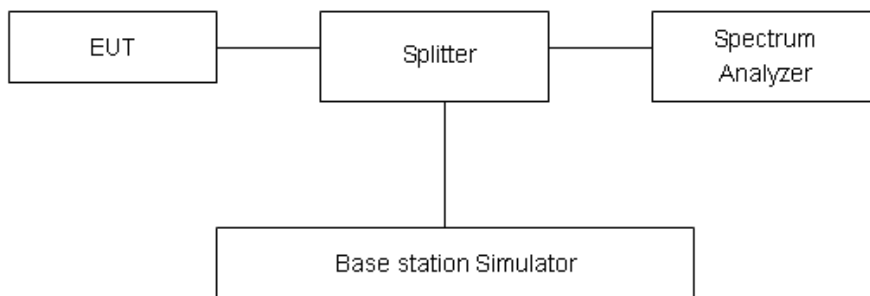

**Limits**

Rule Part 27.53 (g) For operations in the 600 MHz band and the 698-746 MHz band, the power of any emission outside a licensee's frequency band(s) of operation shall be attenuated below the transmitter power (P) within the licensed band(s) of operation, measured in watts, by at least 43 + 10 log (P) dB. Compliance with this provision is based on the use of measurement instrumentation employing a resolution bandwidth of 100 kilohertz or greater. However, in the 100 kilohertz bands immediately outside and adjacent to a licensee's frequency block, a resolution bandwidth of at least 30 kHz may be employed.

Rule Part 27.53(f) For operations in the 746-758 MHz, 775-788 MHz, and 805-806 MHz bands, emissions in the band 1559-1610 MHz shall be limited to –70 dBW/MHz equivalent isotropically radiated power (EIRP) for wideband signals, and –80 dBW EIRP for discrete emissions of less than 700 Hz bandwidth. For the purpose of equipment authorization, a transmitter shall be tested with an antenna that is representative of the type that will be used with the equipment in normal operation.

**NB-IOT B12 Limit**

|       |         |
|-------|---------|
| Limit | -13 dBm |
|-------|---------|

**NB-IOT B13 Limit**

|                                     |         |
|-------------------------------------|---------|
| Limit out of the band 1559-1610 MHz | -13 dBm |
| Limit in the band 1559-1610 MHz     | -40 dBm |

**Measurement Uncertainty**

The assessed measurement uncertainty to ensure 99.75% confidence level for the normal distribution is with the coverage factor  $k = 1.96$ .

| Frequency     | Uncertainty |
|---------------|-------------|
| 100kHz-2GHz   | 0.684 dB    |
| 2GHz-12.75GHz | 1.407 dB    |

**Test Result: PASS**

Sweep from 9 kHz to 30MHz, and the emissions more than 20 dB below the permissible value are not reported.

**Standalone deployment with 15 KHz subcarrier spacing and QPSK mode for CAT NB1:**

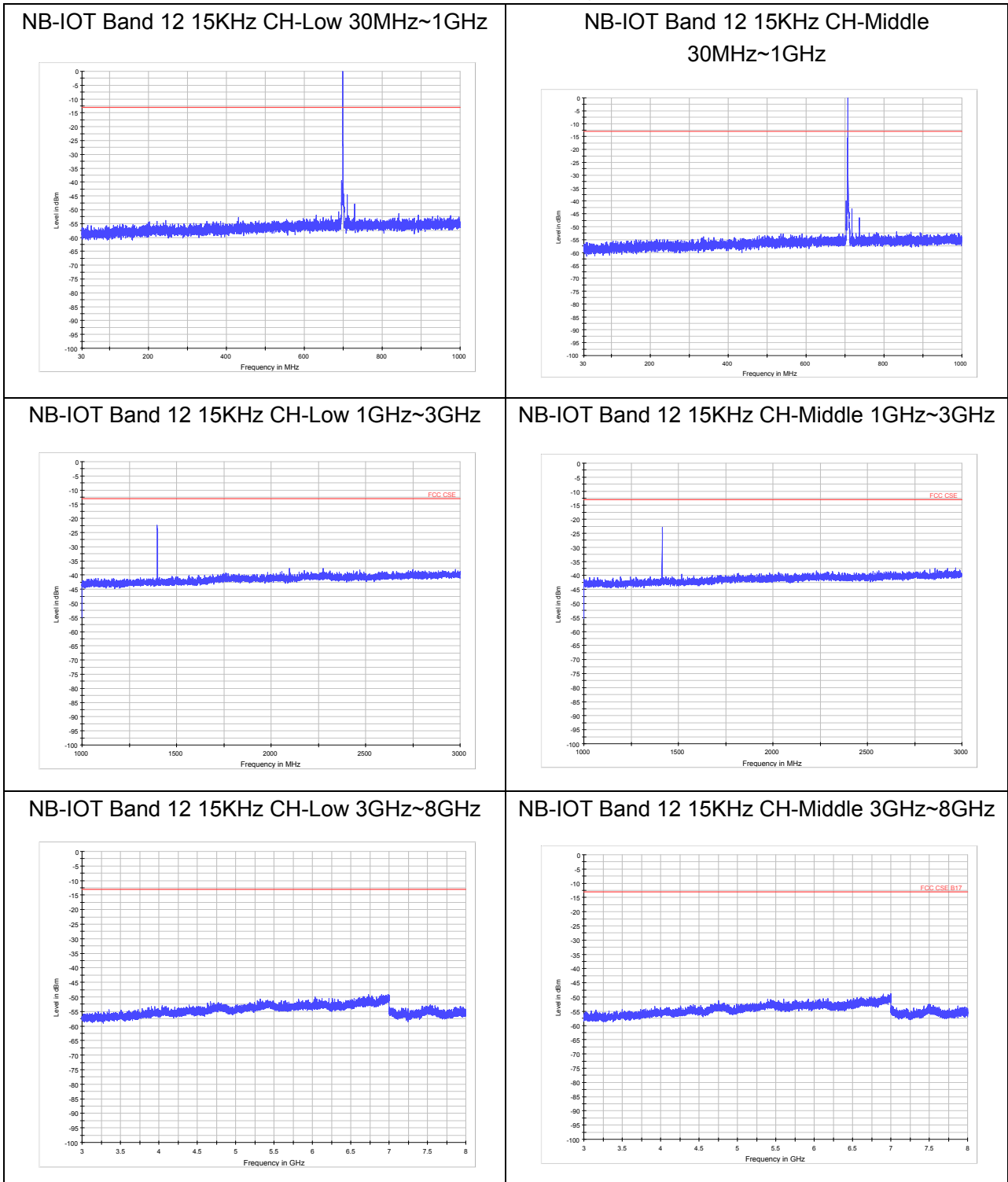

NB-IOT Band 12 15KHz CH-High 30MHz~1GHz

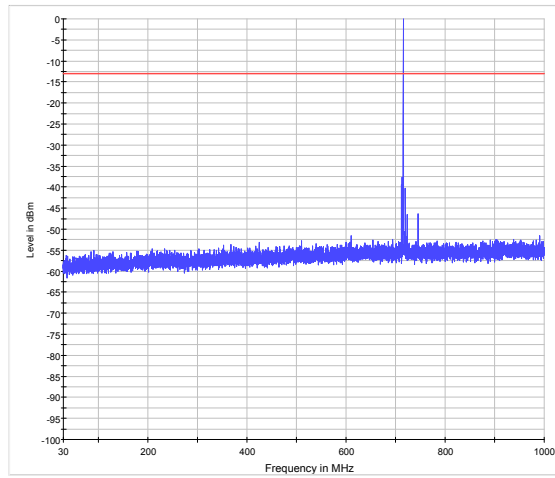

NB-IOT Band 12 15KHz CH-High 1GHz~3GHz

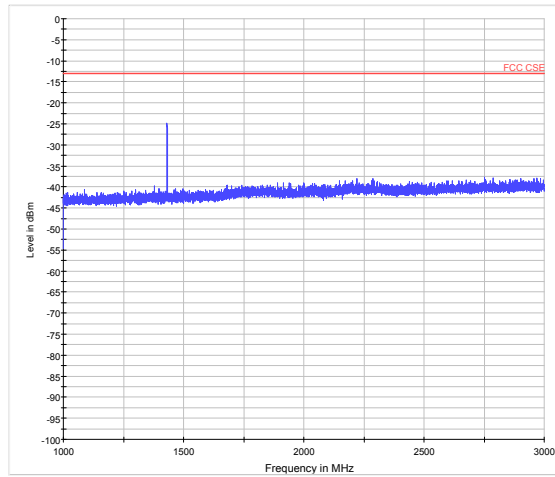

NB-IOT Band 12 15KHz CH-High 3GHz~8GHz

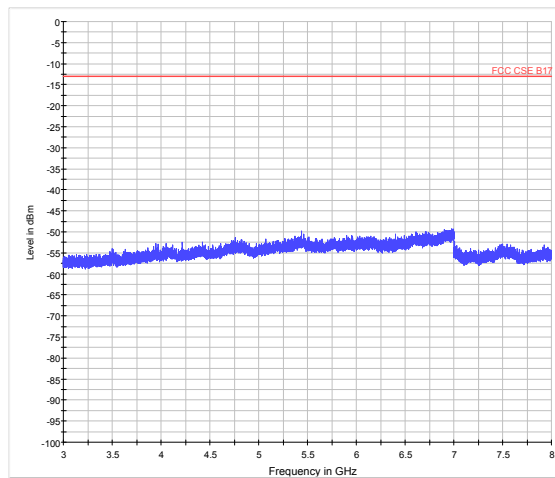

NB-IOTBand 13 15KHz CH-Low 30MHz~1.5GHz

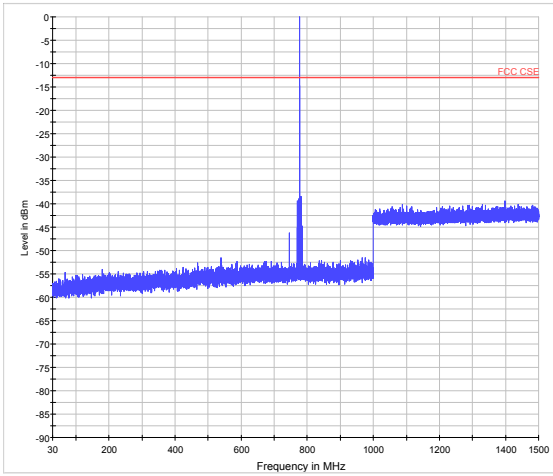

NB-IOT Band 13 15KHz CH-Low 1.5GHz~8GHz

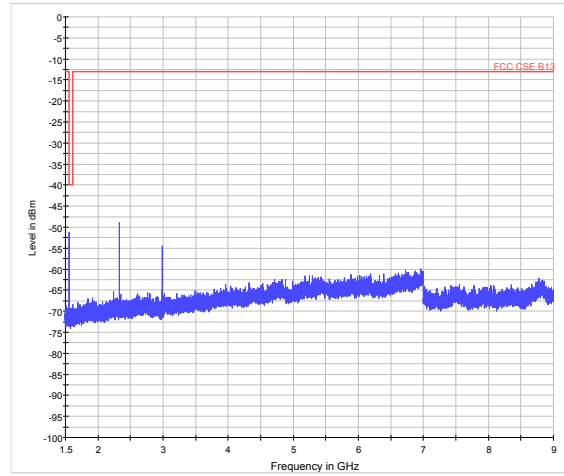

NB-IOT Band 13 15KHz CH-Middle 30MHz~1.5GHz

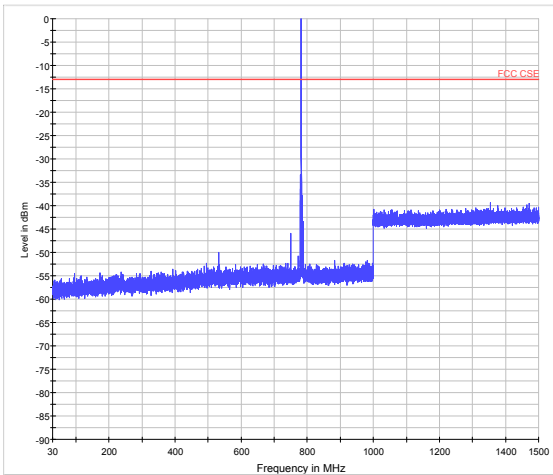

NB-IOT Band 13 15KHz CH-Middle 1.5GHz~8GHz

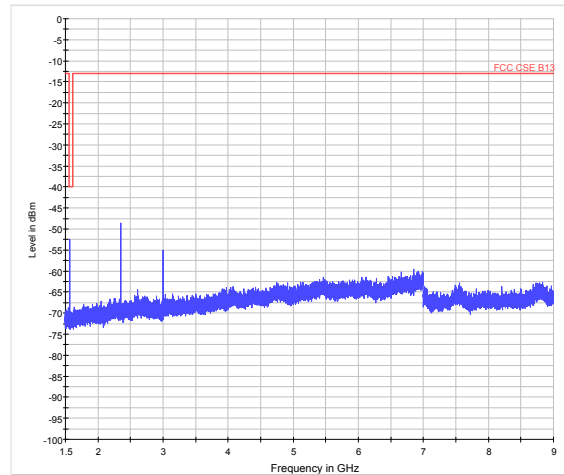

NB-IOTBand13 15KHz CH-High 30MHz~1.5GHz

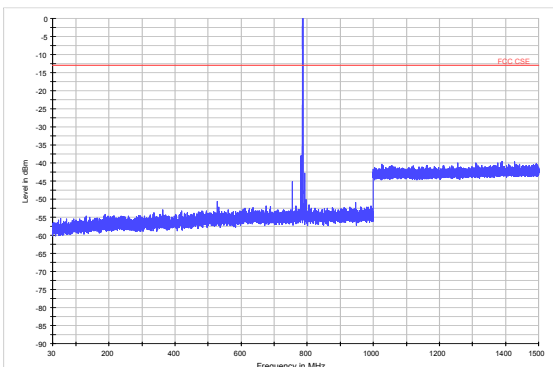

NB-IOT Band 13 15KHz CH-High 1.5GHz~8GHz

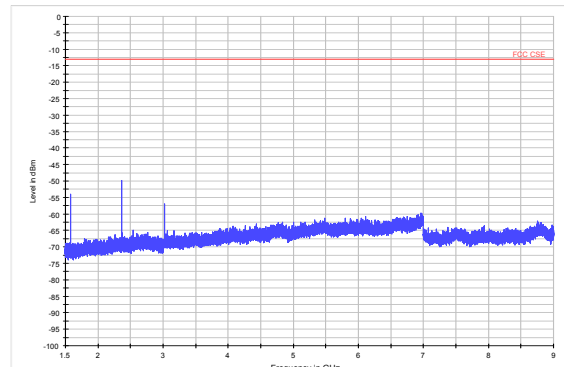



If disturbances were found more than 20dB below limit line, the mark is not required for the EUT.

The signal beyond the limit is carrier in the following plots.

| Test Data File Name            | Frequency (MHz) | Peak (dBm) | Limit (dBm) | Margin (dB) |
|--------------------------------|-----------------|------------|-------------|-------------|
| CSE_NB-IOT B12_CHLOW_1-3GHz    | 1398.0          | -22.39     | -13.00      | 9.39        |
| CSE _ NB-IOT B12_CHMID_1-3GHz  | 1415.3          | -24.33     | -13.00      | 11.33       |
| CSE _ NB-IOT B12_CHHIGH_1-3GHz | 1431.8          | -24.89     | -13.00      | 11.89       |

## 5.8 Radiates Spurious Emission

### Ambient condition

| Temperature | Relative humidity | Pressure |
|-------------|-------------------|----------|
| 23°C ~25°C  | 45%~50%           | 101.5kPa |

### Method of Measurement

1. The testing follows FCC KDB 971168 v02r02 Section 5.8 and ANSI/TIA-603-D-2010.
2. The EUT is placed on a turntable 0.8 meters above the ground in the chamber, 3 meter away from the antenna. The maximal emission value is acquired by adjusting the antenna height, polarisation and turntable azimuth. Normally, the height range of antenna is 1 m to 4 m, the azimuth range of turntable is 0° to 360°, and the receive antenna has two polarizations Vertical (V) and Horizontal (H).
3. A log-periodic antenna or double-ridged waveguide horn antenna shall be substituted in place of the EUT. The log-periodic antenna will be driven by a signal generator and the level will be adjusted till the same power value on the spectrum analyzer or receiver. The level of the spurious emissions can be calculated through the level of the signal generator, cable loss, the gain of the substitution antenna and the reading of the spectrum analyzer or receiver.
4. The EUT is then put into continuously transmitting mode at its maximum power level during the test. Set Test Receiver or Spectrum RBW=1MHz, VBW=3MHz, And the maximum value of the receiver should be recorded as (Pr).
5. The EUT shall be replaced by a substitution antenna. In the chamber, an substitution antenna for the frequency band of interest is placed at the reference point of the chamber. An RF Signal source for the frequency band of interest is connected to the substitution antenna with a cable that has been constructed to not interfere with the radiation pattern of the antenna. A power (PMea) is applied to the input of the substitution antenna, and adjust the level of the signal generator output until the value of the receiver reach the previously recorded (Pr). The power of signal source (PMea) is recorded. The test should be performed by rotating the test item and adjusting the receiving antenna polarization.
6. A amplifier should be connected to the Signal Source output port. And the cable should be connect between the Amplifier and the Substitution Antenna. The cable loss (Pcl) ,the Substitution Antenna Gain (Ga) and the Amplifier Gain (PAg) should be recorded after test.
7. The measurement results are obtained as described below:  

$$\text{Power(EIRP)} = \text{PMea} - \text{PAg} - \text{Pcl} + \text{Ga}$$
 The measurement results are amend as described below:  

$$\text{Power(EIRP)} = \text{PMea} - \text{Pcl} + \text{Ga}$$
8. This value is EIRP since the measurement is calibrated using an antenna of known gain (2.15 dBi) and known input power. ERP can be calculated from EIRP by subtracting the gain of the dipole, ERP = EIRP-2.15dBi.



**Test setup**

**30MHz~~~ 1GHz**

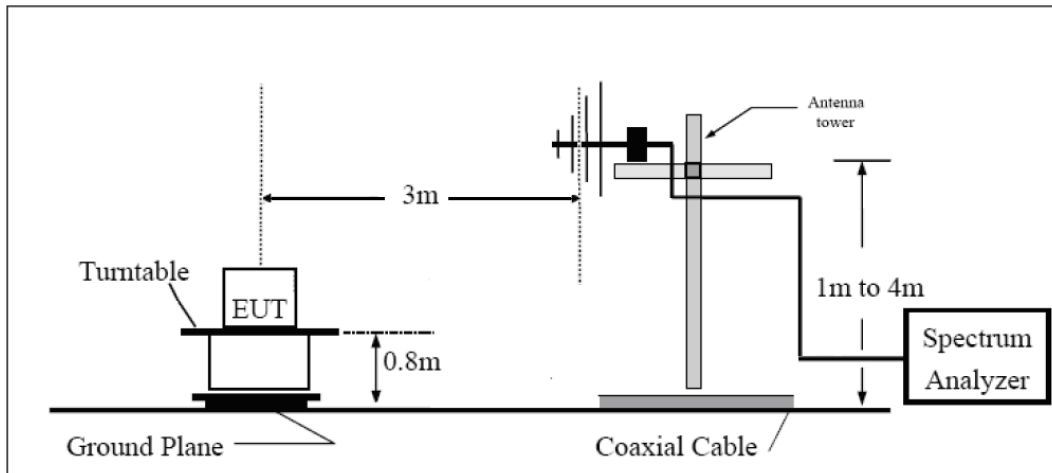

**Above 1GHz**

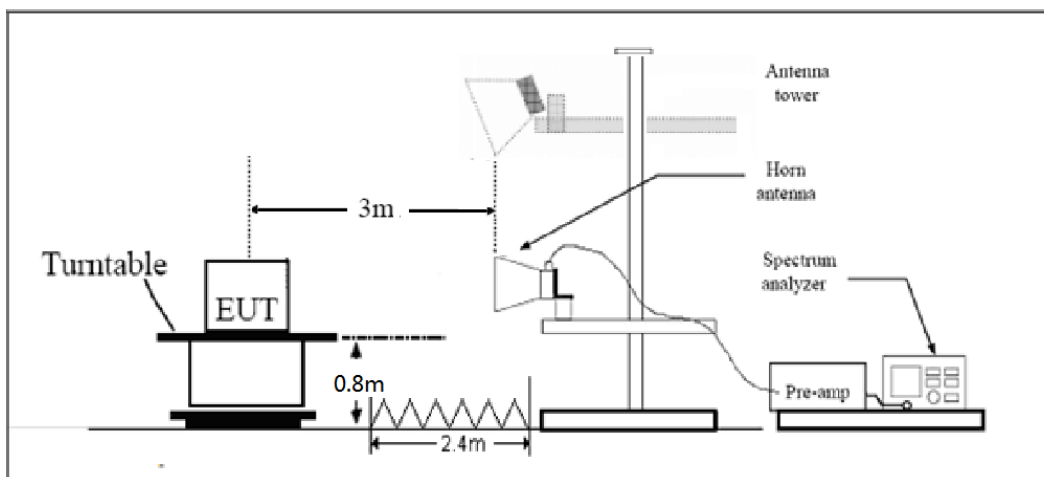

Note: Area side:2.4mX3.6m

The radiated emission was measured in the following position: EUT stand-up position (Z axis), lie-down position (X, Y axis). The worst emission was found in stand-up position (Z axis) and the worst case was recorded.

**Limits**

Rule Part 27.53 (g) For operations in the 600 MHz band and the 698-746 MHz band, the power of any emission outside a licensee's frequency band(s) of operation shall be attenuated below the transmitter power (P) within the licensed band(s) of operation, measured in watts, by at least  $43 + 10 \log (P)$  dB. Compliance with this provision is based on the use of measurement instrumentation employing a resolution bandwidth of 100 kilohertz or greater. However, in the 100 kilohertz bands immediately outside and adjacent to a licensee's frequency block, a resolution bandwidth of at least 30 kHz may be employed.

Rule Part 27.53(f) For operations in the 746-758 MHz, 775-788 MHz, and 805-806 MHz bands, emissions in the band 1559-1610 MHz shall be limited to  $-70$  dBW/MHz equivalent isotropically



radiated power (EIRP) for wideband signals, and  $-80$  dBW EIRP for discrete emissions of less than 700 Hz bandwidth. For the purpose of equipment authorization, a transmitter shall be tested with an antenna that is representative of the type that will be used with the equipment in normal operation.

**NB-IOT Band 12 Limit**

|       |         |
|-------|---------|
| Limit | -13 dBm |
|-------|---------|

**NB-IOT Band 13 Limit**

|                                     |         |
|-------------------------------------|---------|
| Limit out of the band 1559-1610 MHz | -13 dBm |
| Limit in the band 1559-1610 MHz     | -40 dBm |

**Measurement Uncertainty**

The assessed measurement uncertainty to ensure 95% confidence level for the normal distribution is with the coverage factor  $k = \pm 1.96$ ,  $U = \pm 3.55$  dB.

**Test Result**
**Standalone deployment with 15 KHz subcarrier spacing and QPSK mode for CAT NB1:**
**NB-IOT Band 12 15KHz QPSK CH-Low**

| Harmonic | Frequency (MHz) | SG (dBm) | Cable Loss (dB) | Gain (dBi) | Antenna Polarization | ERP Level (dBm) | Limit (dBm) | Margin (dB) | Azimuth (deg) |
|----------|-----------------|----------|-----------------|------------|----------------------|-----------------|-------------|-------------|---------------|
| 2        | 1399.40         | -32.45   | 2.00            | 10.15      | Horizontal           | -26.45          | -13.00      | 13.45       | 90            |
| 3        | 2099.10         | -55.53   | 2.50            | 11.35      | Horizontal           | -48.83          | -13.00      | 35.83       | 135           |
| 4        | 2798.80         | -54.42   | 4.20            | 10.85      | Horizontal           | -49.92          | -13.00      | 36.92       | 45            |
| 5        | 3498.50         | -55.31   | 5.20            | 11.35      | Horizontal           | -51.31          | -13.00      | 38.31       | 270           |
| 6        | 4198.20         | -54.53   | 5.50            | 11.95      | Horizontal           | -50.23          | -13.00      | 37.23       | 225           |
| 7        | 4897.90         | -52.55   | 5.70            | 13.55      | Horizontal           | -46.85          | -13.00      | 33.85       | 135           |
| 8        | 5597.60         | -51.87   | 6.30            | 13.75      | Horizontal           | -46.57          | -13.00      | 33.57       | 135           |
| 9        | 6297.30         | -50.35   | 6.80            | 13.85      | Horizontal           | -45.45          | -13.00      | 32.45       | 315           |
| 10       | 6997.00         | -47.58   | 6.90            | 14.25      | Horizontal           | -42.38          | -13.00      | 29.38       | 0             |

Note: 1.The other Spurious RF Radiated emissions level is no more than noise floor.  
2. The worst emission was found in the antenna is Horizontal position.

**NB-IOT Band 12 15KHz QPSK CH-Middle**

| Harmonic | Frequency (MHz) | SG (dBm) | Cable Loss (dB) | Gain (dBi) | Antenna Polarization | ERP Level (dBm) | Limit (dBm) | Margin (dB) | Azimuth (deg) |
|----------|-----------------|----------|-----------------|------------|----------------------|-----------------|-------------|-------------|---------------|
| 2        | 1415.00         | -32.81   | 2.00            | 10.75      | Horizontal           | -26.21          | -13.00      | 13.21       | 90            |
| 3        | 2122.50         | -53.03   | 2.51            | 11.05      | Horizontal           | -46.64          | -13.00      | 33.64       | 135           |
| 4        | 2830.00         | -54.62   | 4.20            | 11.15      | Horizontal           | -49.82          | -13.00      | 36.82       | 45            |
| 5        | 3537.50         | -52.59   | 5.20            | 11.15      | Horizontal           | -48.79          | -13.00      | 35.79       | 270           |
| 6        | 4245.00         | -53.07   | 5.50            | 11.95      | Horizontal           | -48.77          | -13.00      | 35.77       | 225           |
| 7        | 4952.50         | -52.91   | 5.70            | 13.55      | Horizontal           | -47.21          | -13.00      | 34.21       | 90            |
| 8        | 5660.00         | -51.25   | 6.30            | 13.75      | Horizontal           | -45.95          | -13.00      | 32.95       | 135           |
| 9        | 6367.50         | -49.96   | 6.80            | 13.85      | Horizontal           | -45.06          | -13.00      | 32.06       | 315           |
| 10       | 7075.00         | -46.81   | 6.90            | 14.25      | Horizontal           | -41.61          | -13.00      | 28.61       | 45            |

Note: 1.The other Spurious RF Radiated emissions level is no more than noise floor.  
2. The worst emission was found in the antenna is Horizontal position.

**NB-IOT Band 12 15KHZ QPSK CH-High**

| Harmonic | Frequency (MHz) | SG (dBm) | Cable Loss (dB) | Gain (dBi) | Antenna Polarization | ERP Level (dBm) | Limit (dBm) | Margin (dB) | Azimuth (deg) |
|----------|-----------------|----------|-----------------|------------|----------------------|-----------------|-------------|-------------|---------------|
| 2        | 1430.60         | -35.14   | 2.00            | 10.15      | Horizontal           | -29.14          | -13.00      | 16.14       | 90            |
| 3        | 2145.90         | -51.48   | 2.51            | 11.05      | Horizontal           | -45.09          | -13.00      | 32.09       | 225           |
| 4        | 2861.20         | -54.94   | 4.20            | 11.15      | Horizontal           | -50.14          | -13.00      | 37.14       | 135           |
| 5        | 3576.50         | -52.99   | 5.20            | 11.15      | Horizontal           | -49.19          | -13.00      | 36.19       | 315           |
| 6        | 4291.80         | -52.62   | 5.50            | 11.95      | Horizontal           | -48.32          | -13.00      | 35.32       | 0             |
| 7        | 5007.10         | -51.42   | 5.70            | 13.55      | Horizontal           | -45.72          | -13.00      | 32.72       | 90            |
| 8        | 5722.40         | -50.88   | 6.30            | 13.75      | Horizontal           | -45.58          | -13.00      | 32.58       | 135           |
| 9        | 6437.70         | -49.18   | 6.80            | 13.85      | Horizontal           | -44.28          | -13.00      | 31.28       | 45            |
| 10       | 7153.00         | -46.48   | 6.90            | 14.25      | Horizontal           | -41.28          | -13.00      | 28.28       | 135           |

Note: 1.The other Spurious RF Radiated emissions level is no more than noise floor.  
2. The worst emission was found in the antenna is Horizontal position

**NB-IOT Band 13 15KHZ QPSK CH-Low**

| Harmonic | Frequency (MHz) | SG (dBm) | Cable Loss (dB) | Gain (dBi) | Antenna Polarization | ERP Level (dBm) | Limit (dBm) | Margin (dB) | Azimuth (deg) |
|----------|-----------------|----------|-----------------|------------|----------------------|-----------------|-------------|-------------|---------------|
| 2        | 1497.0          | -54.26   | 2.00            | 10.15      | Horizontal           | -48.26          | -13.00      | 35.26       | 135           |
| 3        | 2245.5          | -51.22   | 2.50            | 11.35      | Horizontal           | -44.52          | -13.00      | 31.52       | 45            |
| 4        | 2994.0          | -53.94   | 4.20            | 10.85      | Horizontal           | -49.44          | -13.00      | 36.44       | 135           |
| 5        | 3742.5          | -52.51   | 5.20            | 11.35      | Horizontal           | -48.51          | -13.00      | 35.51       | 90            |
| 6        | 4491.0          | -51.95   | 5.50            | 11.95      | Horizontal           | -47.65          | -13.00      | 34.65       | 225           |
| 7        | 5239.5          | -51.03   | 5.70            | 13.55      | Horizontal           | -45.33          | -13.00      | 32.33       | 135           |
| 8        | 5988.0          | -49.69   | 6.30            | 13.75      | Horizontal           | -44.39          | -13.00      | 31.39       | 45            |
| 9        | 6736.5          | -48.71   | 6.80            | 13.85      | Horizontal           | -43.81          | -13.00      | 30.81       | 270           |
| 10       | 7485.0          | -46.29   | 6.90            | 14.25      | Horizontal           | -41.09          | -13.00      | 28.09       | 225           |

Note: 1.The other Spurious RF Radiated emissions level is no more than noise floor.  
2. The worst emission was found in the antenna is Horizontal position.

**NB-IOT Band 13 15KHZ+QPSK CH-Middle**

| Harmonic | Frequency (MHz) | SG (dBm) | Cable Loss (dB) | Gain (dBi) | Antenna Polarization | ERP Level (dBm) | Limit (dBm) | Margin (dB) | Azimuth (deg) |
|----------|-----------------|----------|-----------------|------------|----------------------|-----------------|-------------|-------------|---------------|
| 2        | 1502.0          | -55.61   | 2.00            | 10.75      | Horizontal           | -49.01          | -13.00      | 36.01       | 90            |
| 3        | 2253.0          | -51.23   | 2.51            | 11.05      | Horizontal           | -44.84          | -13.00      | 31.84       | 135           |
| 4        | 3004.0          | -54.03   | 4.20            | 11.15      | Horizontal           | -49.23          | -13.00      | 36.23       | 45            |
| 5        | 3755.0          | -50.68   | 5.20            | 11.15      | Horizontal           | -46.88          | -13.00      | 33.88       | 135           |
| 6        | 4506.0          | -50.97   | 5.50            | 11.95      | Horizontal           | -46.67          | -13.00      | 33.67       | 225           |
| 7        | 5257.0          | -51.01   | 5.70            | 13.55      | Horizontal           | -45.31          | -13.00      | 32.31       | 135           |
| 8        | 6008.0          | -50.21   | 6.30            | 13.75      | Horizontal           | -44.91          | -13.00      | 31.91       | 135           |
| 9        | 6759.0          | -48.06   | 6.80            | 13.85      | Horizontal           | -43.16          | -13.00      | 30.16       | 315           |
| 10       | 7510.0          | -46.56   | 6.90            | 14.25      | Horizontal           | -41.36          | -13.00      | 28.36       | 90            |

Note: 1.The other Spurious RF Radiated emissions level is no more than noise floor.  
2. The worst emission was found in the antenna is Horizontal position.

**NB-IOT Band 13 15KHZ+QPSK CH-High**

| Harmonic | Frequency (MHz) | SG (dBm) | Cable Loss (dB) | Gain (dBi) | Antenna Polarization | ERP Level (dBm) | Limit (dBm) | Margin (dB) | Azimuth (deg) |
|----------|-----------------|----------|-----------------|------------|----------------------|-----------------|-------------|-------------|---------------|
| 2        | 1507.0          | -56.89   | 2.00            | 10.15      | Horizontal           | -50.89          | -13.00      | 37.89       | 90            |
| 3        | 2260.5          | -52.21   | 2.51            | 11.05      | Horizontal           | -45.82          | -13.00      | 32.82       | 135           |
| 4        | 3014.0          | -53.81   | 4.20            | 11.15      | Horizontal           | -49.01          | -13.00      | 36.01       | 270           |
| 5        | 3767.5          | -52.63   | 5.20            | 11.15      | Horizontal           | -48.83          | -13.00      | 35.83       | 225           |
| 6        | 4521.0          | -51.63   | 5.50            | 11.95      | Horizontal           | -47.33          | -13.00      | 34.33       | 90            |
| 7        | 5274.5          | -50.48   | 5.70            | 13.55      | Horizontal           | -44.78          | -13.00      | 31.78       | 135           |
| 8        | 6028.0          | -50.31   | 6.30            | 13.75      | Horizontal           | -45.01          | -13.00      | 32.01       | 135           |
| 9        | 6781.5          | -47.44   | 6.80            | 13.85      | Horizontal           | -42.54          | -13.00      | 29.54       | 315           |
| 10       | 7535.0          | -46.31   | 6.90            | 14.25      | Horizontal           | -41.11          | -13.00      | 28.11       | 270           |

Note: 1.The other Spurious RF Radiated emissions level is no more than noise floor.  
2. The worst emission was found in the antenna is Horizontal position.

## 6 Main Test Instruments

| Name                                 | Manufacturer | Type         | Serial Number | Calibration Date | Expiration Time |
|--------------------------------------|--------------|--------------|---------------|------------------|-----------------|
| Base Station Simulator               | R&S          | CMW500       | 113645        | 2017-05-14       | 2018-05-13      |
| Power Splitter                       | Hua Xiang    | SHX-GF2-2-13 | 10120101      | 2017-05-14       | 2018-05-13      |
| Universal Radio Communication Tester | Agilent      | E5515C       | MY48367192    | 2017-05-14       | 2018-05-13      |
| Spectrum Analyzer                    | Agilent      | N9010A       | MY47191109    | 2017-05-14       | 2018-05-13      |
| Signal Analyzer                      | R&S          | FSV30        | 100815        | 2016-12-16       | 2017-12-15      |
| Signal generator                     | R&S          | SMB 100A     | 102594        | 2017-05-14       | 2018-05-13      |
| EMI Test Receiver                    | R&S          | ESCI         | 100948        | 2017-05-20       | 2018-05-19      |
| Trilog Antenna                       | SCHWARZBECK  | VUBL 9163    | 9163-201      | 2014-12-06       | 2017-12-05      |
| Horn Antenna                         | R&S          | HF907        | 100126        | 2014-12-06       | 2017-12-05      |
| Horn Antenna                         | ETS-Lindgren | 3160-09      | 00102643      | 2015-01-30       | 2018-01-29      |
| Climatic Chamber                     | Re Ce        | PT-30B       | 20101891      | 2015-07-18       | 2018-07-17      |
| RF Cable                             | Agilent      | SMA 15cm     | 0001          | 2017-08-04       | 2018-02-03      |
| Preamplifier                         | R&S          | SCU18        | 102327        | 2017-06-18       | 2018-06-17      |

## ANNEX A: EUT Appearance and Test Setup

### A.1 EUT Appearance



Front Side



Back Side



Shield

a: EUT

**Picture 1 EUT and Accessory**



## A.2 Test Setup

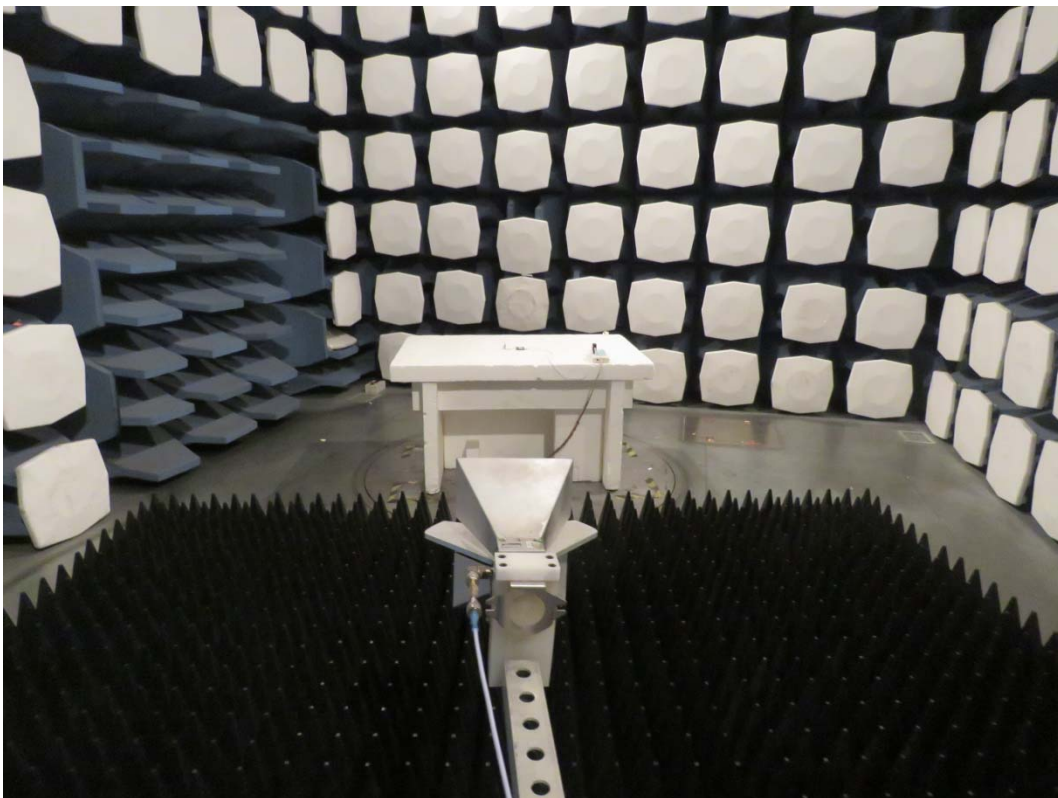
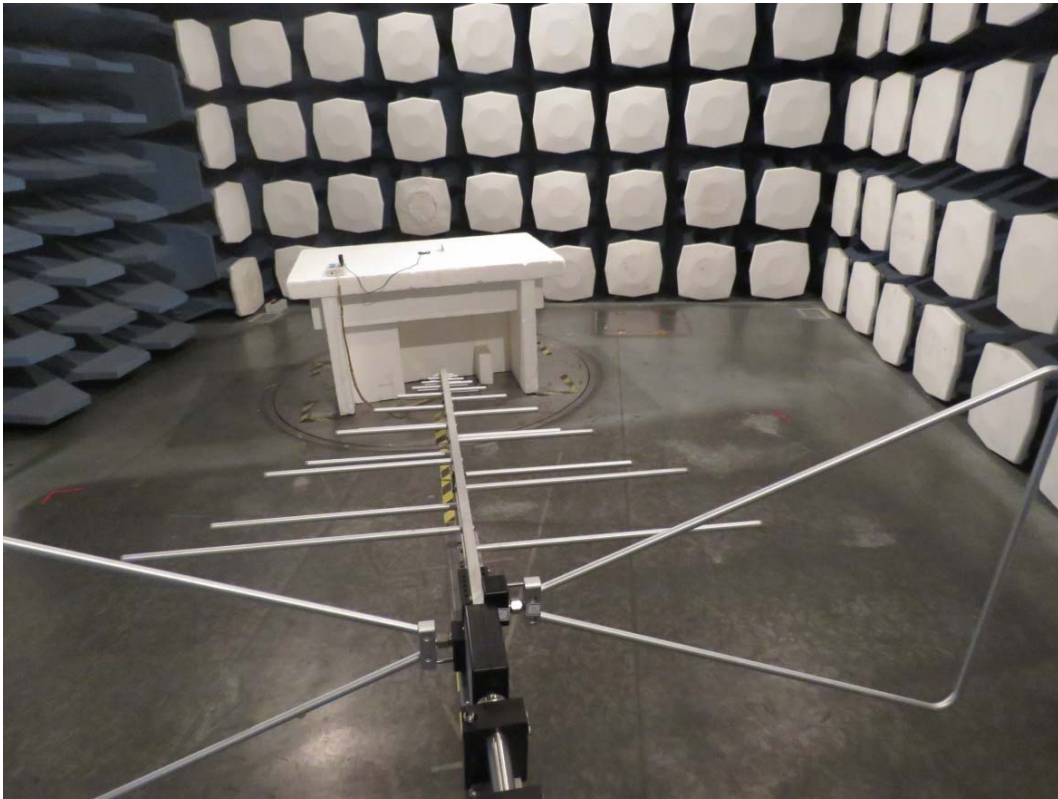

Picture 2: Radiated Spurious Emissions Test setup