



SAR TEST REPORT

Applicant ZTE Corporation
FCC ID SRQ-Z6750M
Product 5G NR Multi-Mode Mobile Phone
Model Z6750M
Report No. R2008A0534-S1V1
Issue Date October 28, 2020

TA Technology (Shanghai) Co., Ltd. tested the above equipment in accordance with the requirements in **IEEE 1528-2013, ANSI C95.1: 1992, IEEE C95.1: 1991**. The test results show that the equipment tested is capable of demonstrating compliance with the requirements as documented in this report.

Prepared by: Yu Wang

Approved by: Guangchang Fan

TA Technology (Shanghai) Co., Ltd.

No.145, Jintang Rd, Tangzhen Industry Park, Pudong Shanghai, China

TEL: +86-021-50791141/2/3

FAX: +86-021-50791141/2/3-8000

Table of Contents

1	Test Laboratory.....	5
1.1	Notes of the Test Report.....	5
1.2	Test facility.....	5
1.3	Testing Location.....	5
1.4	Laboratory Environment.....	6
2	Statement of Compliance.....	7
3	Description of Equipment under Test.....	8
4	Test Specification, Methods and Procedures.....	11
5	Operational Conditions during Test.....	12
5.1	Test Positions.....	12
5.1.1	Against Phantom Head.....	12
5.1.2	Body Worn Configuration.....	12
5.1.3	Phablet SAR test considerations.....	13
5.2	Measurement Variability.....	13
5.3	Test Configuration.....	15
5.3.1	LTE Test Configuration.....	15
5.3.2	5G NR Test Configuration.....	16
5.3.3	Wi-Fi Test Configuration.....	17
5.3.4	BT Test Configuration.....	18
5.3.5	LTE CA specification.....	19
5.3.6	Power Reduction Configuration.....	20
6	SAR Measurements System Configuration.....	25
6.1	SAR Measurement Set-up.....	25
6.2	DASY5 E-field Probe System.....	26
6.3	SAR Measurement Procedure.....	27
7	Main Test Equipment.....	29
8	Tissue Dielectric Parameter Measurements & System Verification.....	30
8.1	Tissue Verification.....	30
8.2	System Performance Check.....	32
8.3	SAR System Validation.....	34
9	Normal and Maximum Output Power.....	35
9.1	LTE Mode.....	35
9.1.1	LTE CA.....	73
9.2	EN-DC Mode.....	74
9.2.1	LTE (EN-DC).....	75
9.2.2	NR (EN-DC).....	96
9.3	WLAN Mode.....	111
9.4	Bluetooth Mode.....	115
10	Measured and Reported (Scaled) SAR Results.....	116
10.1	EUT Antenna Locations.....	116
10.2	Measured SAR Results.....	118



10.3	Simultaneous Transmission Analysis	145
11	Measurement Uncertainty	150
ANNEX A:	Test Layout.....	151
ANNEX B:	System Check Results.....	153
ANNEX C:	Highest Graph Results.....	165
ANNEX D:	Probe Calibration Certificate.....	213
ANNEX E:	D750V3 Dipole Calibration Certificate.....	222
ANNEX F:	D835V2 Dipole Calibration Certificate.....	230
ANNEX G:	D1750V2 Dipole Calibration Certificate	238
ANNEX H:	D1900V2 Dipole Calibration Certificate	246
ANNEX I:	D2450V2 Dipole Calibration Certificate	254
ANNEX J:	D5GHzV2 Dipole Calibration Certificate	262
ANNEX K:	DAE4 Calibration Certificate	276
ANNEX L:	The EUT Appearance	281
ANNEX M:	Test Setup Photos	282



Version	Revision description	Issue Date
Rev.0	/	October 27, 2020
Rev.1	Update chapter dislocation. Increase CA_66B SAR data.	October 28, 2020
Note This revised report (Report No. R2008A0534-S1V1) supersedes and replaces the previously issued report (Report No. R2008A0534-S1). Please discard or destroy the previously issued report and dispose of it accordingly.		

1 Test Laboratory

1.1 Notes of the Test Report

This report shall not be reproduced in full or partial, without the written approval of **TA technology (shanghai) co., Ltd.** The results documented in this report apply only to the tested sample, under the conditions and modes of operation as described herein .Measurement Uncertainties were not taken into account and are published for informational purposes only. This report is written to support regulatory compliance of the applicable standards stated above.

1.2 Test facility

FCC (Designation number: CN1179, Test Firm Registration Number: 446626)

TA Technology (Shanghai) Co., Ltd. has been listed on the US Federal Communications Commission list of test facilities recognized to perform electromagnetic emissions measurements.

A2LA (Certificate Number: 3857.01)

TA Technology (Shanghai) Co., Ltd. has been listed by American Association for Laboratory Accreditation to perform electromagnetic emission measurement.

1.3 Testing Location

Company: TA Technology (Shanghai) Co., Ltd.
Address: No.145, Jintang Rd, Tangzhen Industry Park, Pudong Shanghai, China
City: Shanghai
Post code: 201201
Country: P. R. China
Contact: Fan Guangchang
Telephone: +86-021-50791141/2/3
Fax: +86-021-50791141/2/3-8000
Website: <http://www.ta-shanghai.com>
E-mail: fanguangchang@ta-shanghai.com



1.4 Laboratory Environment

Temperature	Min. = 18°C, Max. = 25 °C
Relative humidity	Min. = 30%, Max. = 70%
Ground system resistance	< 0.5 Ω
Ambient noise is checked and found very low and in compliance with requirement of standards. Reflection of surrounding objects is minimized and in compliance with requirement of standards.	

2 Statement of Compliance

The maximum results of Specific Absorption Rate (SAR) found during testing for the EUT are as follows:

Table 1: Highest Reported SAR

Mode		Highest Reported SAR (W/kg)			
		1g SAR Head	1g SAR Body-worn	1g SAR Hotspot	Product Specific 10-g SAR
LTE	FDD 2	0.092	1.496	1.026	2.514
	FDD 4	0.141	0.666	1.107	2.557
	FDD 5	1.421	0.565	0.671	NA
	FDD 12	0.168	0.066	0.098	NA
	FDD 13	0.876	0.590	0.648	NA
	FDD 66	0.064	0.859	1.364	3.657
LTE (EN-DC)	FDD 2	0.068	0.125	0.170	NA
	FDD 66	0.137	0.292	0.409	NA
NR (EN-DC)	n2	0.331	0.424	0.688	NA
	n5	1.350	0.470	0.761	NA
	n66	0.317	0.493	0.850	NA
Wi-Fi (2.4G)		0.889	0.212	0.399	NA
Wi-Fi (5G)		0.638	0.437	1.194	NA
BT		0.155	0.106	0.106	NA
Date of Testing:		August 25, 2020 ~ October 17, 2020			
Note: All indications of Pass/Fail in this report are opinions expressed by TA Technology (Shanghai) Co., Ltd. based on interpretations and/or observations of test results. Measurement Uncertainties were not taken into account and are published for informational purposes only.					

Table 2: Highest Simultaneous Transmission SAR

Exposure Configuration	1g SAR Head	1g SAR Body-worn (Separation 15mm)	1g SAR Hotspot (Separation 10mm)	Product Specific 10-g SAR (Separation 0mm)
Highest Simultaneous Transmission SAR (W/kg)	1.568	1.580	1.403	3.657
Note: 1. The detail for simultaneous transmission consideration is described in chapter 10.4.				

3 Description of Equipment under Test

Client Information

Applicant	ZTE Corporation
Applicant address	ZTE Plaza, Keji Road South, Hi-Tech, Industrial Park, Nanshan District, Shenzhen, Guangdong, 518057, P.R.China
Manufacturer	ZTE Corporation
Manufacturer address	ZTE Plaza, Keji Road South, Hi-Tech, Industrial Park, Nanshan District, Shenzhen, Guangdong, 518057, P.R.China

General Technologies

Application Purpose:	Original Grant
EUT Stage:	Identical Prototype
Model:	Z6750M
IMEI:	865633050002817
Hardware Version:	Z6750MHW1.0
Software Version:	Z6750MV1.0.0B01
Antenna Type:	Internal Antenna
Device Class:	B
Wi-Fi Hotspot:	Wi-Fi 2.4G Wi-Fi 5G U-NII-1&U-NII-3
Power Class:	LTE FDD 2/4/5/12/13/66: 3 NR FDD n2/n5/n66: 3
Power Level:	LTE FDD 2/4/5/12/13/66: max power NR FDD n2/n5/n66: max power
EUT Accessory	
Battery	Manufacturer: COSMX Model: Li3939T44P8h756547
Adapter 1	Manufacturer: SHENZHEN RUIJING INDUSTRIAL CO LTD Model: STC-A5930A1-Z
Adapter 2	Manufacturer: Jiangsu Chenyang Electron Co., Ltd. Model: STC-A5930A1-Z
USB Cable 1	Manufacturer: kingpower-tech Model: USB-TC30-W-100-M
USB Cable 2	Manufacturer: Luxshare Precision industry Co., Ltd. Model: USB-TC30-W-100-M
<p>Note: 1. The EUT is sent from the applicant to TA and the information of the EUT is declared by the applicant.</p> <p>2. This device support DPS (Dynamic Power Share) function to achieve higher uplink data rata</p>	



keeping the total power unchanged in 5G NSA EN-DC mode according to 3GPP 38.213, when the equipment has a dynamic power sharing capability, it adjusts the LTE or NR transmission power so that the instantaneous total power does not exceed the specified value, when the maximum transmission power of NR (P_{LTE} , P_{NR}) and the specified total power (P_{total}) have been set and the instantaneous calculated total transmission power exceeds P_{total} , the NR transmission power is reduced so that the actual transmission power of the user equipment will not exceed P_{total} power.

3. For EN-DC DPS function, considering two conditions, one is the maximum total power tend to 5G NR bands (5G NR maximum SAR) , the other is the maximum total tend to LTE bands (5G NR minimum SAR), summed 5G NR(maximum power) SAR or LTE (maximum power) SAR as EN-DC SAR to consider simultaneous transmission evaluation.

Wireless Technology and Frequency Range

Wireless Technology		Modulation	Operating mode	Tx (MHz)
LTE	FDD 2	QPSK, 16QAM, 64QAM	Rel.15	1850 ~ 1910
	FDD 4			1710 ~ 1755
	FDD 5			824 ~ 849
	FDD 12			699 ~ 716
	FDD 13			777 ~ 787
	FDD 66			1710 ~ 1780
Does this device support Carrier Aggregation (CA) <input checked="" type="checkbox"/> Yes <input type="checkbox"/> No				
Does this device support SV-LTE (1xRTT-LTE)? <input type="checkbox"/> Yes <input checked="" type="checkbox"/> No				
NR	FDD n2	CP-OFDM: QPSK, 16QAM, 64QAM, 256QAM; DFT-s OFDM: PI/2 BPSK, QPSK, 16QAM, 64QAM, 256QAM	/	1850 ~ 1910
	FDD n5			824 ~ 849
	FDD n66			1710 ~ 1780
BT	2.4G	Version 5.1 LE		2402 ~2480
Wi-Fi	2.4G	DSSS,OFDM	802.11b/g/n HT20	2412 ~ 2462
		OFDM	802.11n HT40	2422 ~ 2452
	5G	OFDM	802.11a/n HT20/ HT40/ ac VHT20/ VHT40/ VHT80	5150 ~ 5250 5725 ~ 5850
Does this device support MIMO <input type="checkbox"/> Yes <input checked="" type="checkbox"/> No				
NFC	13.56MHz			

4 Test Specification, Methods and Procedures

The tests documented in this report were performed in accordance with FCC 47 CFR § 2.1093, IEEE 1528- 2013, ANSI C95.1: 1992, IEEE C95.1: 1991, the following FCC Published RF exposure KDB procedures:

IEC 62209-1

Reference Standards

KDB 248227 D01 802.11Wi-Fi SAR v02r02

KDB 447498 D01 General RF Exposure Guidance v06

KDB 648474 D04 Handset SAR v01r03

KDB 690783 D01 SAR Listings on Grants v01r03

KDB 865664 D01 SAR measurement 100 MHz to 6 GHz v01r04

KDB 865664 D02 RF Exposure Reporting v01r02

KDB 941225 D05 SAR for LTE Devices v02r05

KDB 941225 D05A LTE Rel.10 KDB Inquiry Sheet v01r02

KDB 941225 D06 Hotspot Mode v02r01

5 Operational Conditions during Test

5.1 Test Positions

5.1.1 Against Phantom Head

Measurements were made in “cheek” and “tilt” positions on both the left hand and right hand sides of the phantom.

The positions used in the measurements were according to IEEE 1528 - 2013 "IEEE Recommended Practice for Determining the Peak Spatial-Average Specific Absorption Rate(SAR) in the Human Head from Wireless Communications Devices: Measurement Techniques".

5.1.2 Body Worn Configuration

Body-worn operating configurations should be tested with the belt-clips and holsters attached to the device and positioned against a flat phantom in normal use configurations.

Per FCC KDB Publication 648474 D04, Body-worn accessory exposure is typically related to voice mode operations when handsets are carried in body-worn accessories. The body-worn accessory procedures in FCC KDB Publication 447498 D01 should be used to test for body-worn accessory SAR compliance, without a headset connected to it. This enables the test results for such configuration to be compatible with that required for hotspot mode when the body-worn accessory test separation distance is greater than or equal to that required for hotspot mode, when applicable. When the reported SAR for a body-worn accessory, measured without a headset connected to the handset, is > 1.2 W/kg, the highest reported SAR configuration for that wireless mode and frequency band should be repeated for that body-worn accessory with a headset attached to the handset.

Accessories for Body-worn operation configurations are divided into two categories: those that do not contain metallic components and those that do contain metallic components. When multiple accessories that do not contain metallic components are supplied with the device, the device is tested with only the accessory that dictates the closest spacing to the body. Then multiple accessories that contain metallic components are tested with the device with each accessory. If multiple accessories share an identical metallic component (i.e. the same metallic belt-clip used with different holsters with no other metallic components) only the accessory that dictates the closest spacing to the body is tested.

Body-worn accessories may not always be supplied or available as options for some devices intended to be authorized for body-worn use. In this case, a test configuration with a separation distance between the back of the device and the flat phantom is used. Test position spacing was documented. Transmitters that are designed to operate in front of a person's face, as in push-to-talk configurations, are tested for SAR compliance with the front of the device positioned to face the flat phantom in head fluid. For devices that are carried next to the body such as a shoulder, waist or chest-worn transmitters, SAR compliance is tested with the accessories, including headsets and microphones, attached to the device and positioned against a flat phantom in a normal use configuration.

5.1.3 Phablet SAR test considerations

For smart phones, with a display diagonal dimension > 15.0 cm or an overall diagonal dimension > 16.0 cm, that can provide similar mobile web access and multimedia support found in mini-tablets or UMPC mini-tablets and support voice calls next to the ear, unless it is confirmed otherwise through KDB inquiries, the following phablet procedures should be applied to evaluate SAR compliance for each applicable wireless modes and frequency band. Devices marketed as phablets, regardless of form factors and operating characteristics must be tested as a phablet to determine SAR compliance.

a) The normally required head and body-worn accessory SAR test procedures for handsets, including hotspot mode, must be applied.

b) The UMPC mini-tablet procedures must also be applied to test the SAR of all surfaces and edges with an antenna located at ≤ 25 mm from that surface or edge, in direct contact with a flat phantom, for product specific 10-g SAR according to the body-equivalent tissue dielectric parameters in KDB Publication 865664 D01 to address interactive hand use exposure conditions. The 1-g SAR at 5 mm for UMPC mini-tablets is not required. When hotspot mode applies, product specific 10-g SAR is required only for the surfaces and edges with hotspot mode 1-g reported SAR > 1.2 W/kg; however, when power reduction applies to hotspot mode the measured SAR must be scaled to the maximum output power, including tolerance, allowed for phablet modes to compare with the 1.2 W/kg SAR test reduction threshold. The normal tablet procedures in KDB Publication 616217 are required when the overall diagonal dimension of the device is > 20.0 cm. Hotspot mode SAR is not required when normal tablet procedures are applied. Product specific 10-g SAR is also not required for the front (top) surface of larger form factor full size tablets. The more conservative normal tablet SAR results can be used to support phablet mode product specific 10-g SAR.

c) The simultaneous transmission operating configurations applicable to voice and data transmissions for both phone and mini-tablet modes must be taken into consideration separately for 1-g and 10-g SAR to determine the simultaneous transmission SAR test exclusion and measurement requirements for the relevant wireless modes and exposure conditions.

5.2 Measurement Variability

Per FCC KDB Publication 865664 D01, SAR measurement variability was assessed for each frequency band, which was determined by the SAR probe calibration point and tissue-equivalent medium used for the device measurements. When both head and body tissue-equivalent media were required for SAR measurements in a frequency band, the variability measurement procedures were applied to the tissue medium with the highest measured SAR, using the highest measured SAR configuration for that tissue-equivalent medium. These additional measurements were repeated after the completion of all measurements requiring the same head or body tissue-equivalent medium in a frequency band. The test device was returned to ambient conditions (normal room temperature) with the battery fully charged before it was re-mounted on the device holder for the repeated measurement(s) to minimize any unexpected variations in the repeated results.

SAR Measurement Variability was assessed using the following procedures for each frequency band:



- 1) When the original highest measured SAR is ≥ 0.80 W/kg, the measurement was repeated once.
- 2) A second repeated measurement was performed only if the ratio of largest to smallest SAR for the original and first repeated measurements was > 1.20 or when the original or repeated measurement was ≥ 1.45 W/kg (~ 10% from the 1-g SAR limit).
- 3) A third repeated measurement was performed only if the original, first or second repeated measurement was ≥ 1.5 W/kg and the ratio of largest to smallest SAR for the original, first and second repeated measurements is > 1.20 .
- 4) Repeated measurements are not required when the original highest measured SAR is < 0.80 W/kg

The same procedures should be adapted for measurements according to extremity and occupational exposure limits by applying a factor of 2.5 for extremity exposure and a factor of 5 for occupational exposure to the corresponding SAR thresholds.

5.3 Test Configuration

5.3.1 LTE Test Configuration

LTE modes were tested according to FCC KDB 941225 D05 publication. Please see notes after the tabulated SAR data for required test configurations. Establishing connections with base station simulators ensure a consistent means for testing SAR and are recommended for evaluating SAR [4]. The R&S CMW500 was used for LTE output power measurements and SAR testing. Max power control was used so the UE transmits with maximum output power during SAR testing. SAR must be measured with the maximum TTI (transmit time interval) supported by the device in each LTE configuration.

A) Spectrum Plots for RB Configurations

A properly configured base station simulator was used for SAR tests and power measurements. Therefore, spectrum plots for RB configurations were not required to be included in this report.

B) MPR

MPR is permanently implemented for this device by the manufacturer. The specific manufacturer target MPR is indicated alongside the SAR results. MPR is enabled for this device, according to 3GPP TS36.101 Section 6.2.3 – 6.2.5 under Table 6.2.3-1.

C)A-MPR

A-MPR (Additional MPR) has been disabled for all SAR tests by setting NS=01 on the base station simulator.

D) Largest channel bandwidth standalone SAR test requirements

1) QPSK with 1 RB allocation

Start with the largest channel bandwidth and measure SAR for QPSK with 1 RB allocation, using the RB offset and required test channel combination with the highest maximum output power for RB offsets at the upper edge, middle and lower edge of each required test channel. When the reported SAR is ≤ 0.8 W/kg, testing of the remaining RB offset configurations and required test channels is not required for 1 RB allocation; otherwise, SAR is required for the remaining required test channels and only for the RB offset configuration with the highest output power for that channel. When the reported SAR of a required test channel is > 1.45 W/kg, SAR is required for all three RB offset configurations for that required test channel.

2) QPSK with 50% RB allocation

The procedures required for 1 RB allocation in 1) are applied to measure the SAR for QPSK with 50% RB allocation.

3) QPSK with 100% RB allocation

For QPSK with 100% RB allocation, SAR is not required when the highest maximum output power for 100 % RB allocation is less than the highest maximum output power in 50% and 1 RB allocations and the highest reported SAR for 1 RB and 50% RB allocation in 1) and 2) are ≤ 0.8 W/kg. Otherwise, SAR is measured for the highest output power channel and if the reported SAR is > 1.45 W/kg, the remaining required test channels must also be tested.

4) Higher order modulations

For each modulation besides QPSK; e.g., 16-QAM, 64-QAM, apply the QPSK procedures in above sections to determine the QAM configurations that may need SAR measurement. For each configuration identified as required for testing, SAR is required only when the highest maximum output power for the configuration in the higher order modulation is $> \frac{1}{2}$ dB higher than the same configuration in QPSK or when the reported SAR for the QPSK configuration is > 1.45 W/kg.

E) Other channel bandwidth standalone SAR test requirements

For the other channel bandwidths used by the device in a frequency band, apply all the procedures required for the largest channel bandwidth in section A) to determine the channels and RB configurations that need SAR testing and only measure SAR when the highest maximum output power of a configuration requiring testing in the smaller channel bandwidth is $> \frac{1}{2}$ dB higher than the equivalent channel configurations in the largest channel bandwidth configuration or the *reported* SAR of a configuration for the largest channel bandwidth is > 1.45 W/kg.

5.3.2 5G NR Test Configuration

For 5G NR SAR testing, due to test setup limitations, SAR testing for NR was performed using factory test mode software to establish the connection and perform SAR with 100% transmission.

The DFT-s-OFDM and CP-OFDM waveforms were investigated, and DFT-s-OFDM was found to be the worst case.

The worst-case scenario for all measurements is based on an engineering evaluation and QPSK was observed as the worst one and set for all conducted and radiated. Output power measurements were measured on QPSK, 16QAM, 64QAM, 256QAM, and BPSK, modulations.

5.3.3 Wi-Fi Test Configuration

SAR test reduction for 802.11 Wi-Fi transmission mode configurations are considered separately for DSSS and OFDM. An initial test position is determined to reduce the number of tests required for certain exposure configurations with multiple test positions. An initial test configuration is determined for each frequency band and aggregated band according to maximum output power, channel bandwidth, wireless mode configurations and other operating parameters to streamline the measurement requirements. For 2.4 GHz DSSS, either the initial test position or DSSS procedure is applied to reduce the number of SAR tests; these are mutually exclusive. For OFDM, an initial test position is only applicable to next to the ear, UMPC mini-tablet and hotspot mode configurations, which is tested using the initial test configuration to facilitate test reduction. For other exposure conditions with a fixed test position, SAR test reduction is determined using only the initial test configuration.

The multiple test positions require SAR measurements in head, hotspot mode or UMPC mini-tablet configurations may be reduced according to the highest reported SAR determined using the *initial test position(s)* by applying the DSSS or OFDM SAR measurement procedures in the required wireless mode test configuration(s). The *initial test position(s)* is measured using the highest measured maximum output power channel in the required wireless mode test configuration(s). When the *reported SAR* for the *initial test position* is:

- ≤ 0.4 W/kg, further SAR measurement is not required for the other test positions in that exposure configuration and wireless mode combination within the frequency band or aggregated band. DSSS and OFDM configurations are considered separately according to the required SAR procedures.
- 0.4 W/kg, SAR is repeated using the same wireless mode test configuration tested in the *initial test position* to measure the subsequent next closet/smallest test separation distance and maximum coupling test position, on the highest maximum output power channel, until the *reported SAR* is ≤ 0.8 W/kg or all required test positions are tested.
 - ◇ For subsequent test positions with equivalent test separation distance or when exposure is dominated by coupling conditions, the position for maximum coupling condition should be tested.
 - ◇ When it is unclear, all equivalent conditions must be tested.
- For all positions/configurations tested using the *initial test position* and subsequent test positions, when the *reported SAR* is > 0.8 W/kg, measure the SAR for these positions/configurations on the subsequent next highest measured output power channel(s) until the *reported SAR* is ≤ 1.2 W/kg or all required test channels are considered.
 - ◇ The additional power measurements required for this step should be limited to those necessary for identifying subsequent highest output power channels to apply the test reduction.

To determine the initial test position, Area Scans were performed to determine the position with the Maximum Value of SAR (measured). The position that produced the highest Maximum Value of SAR is considered the worst case position; thus used as the initial test position.

A Wi-Fi device must be configured to transmit continuously at the required data rate, channel bandwidth and signal modulation, using the highest transmission duty factor supported by the test mode tools for SAR measurement.



5.3.4 BT Test Configuration

For BT SAR testing, BT engineering testing software installed on the EUT can provide continuous transmitting RF signal with maximum output power. And the CBT control the EUT operating with hopping off and data rate set for DH5.

The SAR measurement takes full account of the BT duty cycle and is reflected in the report, and the duty factor of the device is as follow:

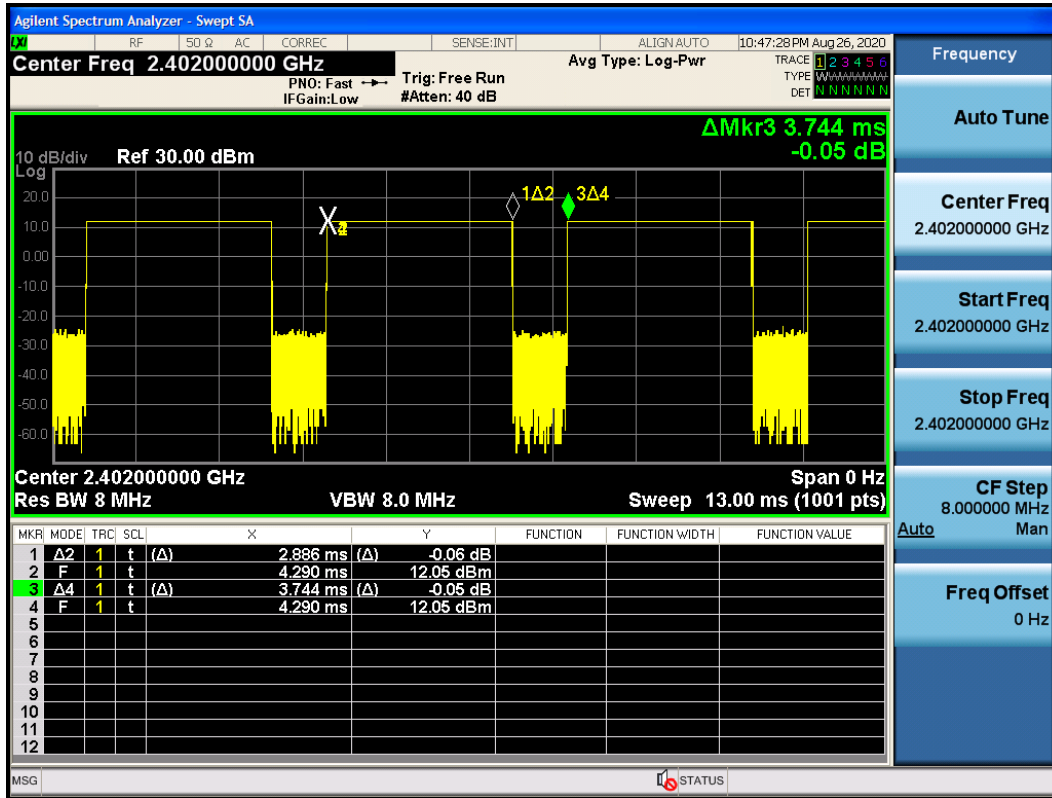

Note: Duty factor= Ton (ms)/ T(on+off) (ms)=2.886/3.744=77.1%

5.3.5 LTE CA specification

The device supports LTE advanced Rel. 15, Carrier Aggregation (CA) on downlink for Intra band and inter-band. Uplink CA is supported for Intra band only, more details information is provided in tables below:

1) DL CA Intra band contiguous

E-UTRA CA configuration / Bandwidth combination set						
E-UTRA CA configuration	Uplink CA configurations	Component carriers in order of increasing carrier frequency			Bandwidth combination set	
		Channel bandwidths for carrier [MHz]	Channel bandwidths for carrier [MHz]	Channel bandwidths for carrier [MHz]		
CA_5B	NA	5,10	10		20	0
		10	5			
CA_66B	NA	5	5, 10, 15		20	0
		10	5, 10			
		15	5			
CA_66C	NA	10	15, 20		40	0
		15	10, 15, 20			
		20	5, 15, 10, 20			

NOTE 1: The CA configuration refers to an operating band and a CA bandwidth class specified in Table 5.6A-1 (the indexing letter). Absence of a CA bandwidth class for an operating band implies support of all classes.



5.3.6 Power Reduction Configuration

Overview of power reduction scenarios

The mobile phone device meets SAR requirements by accurately reducing the power of various scenes. Mainly the following scenarios:

- 1) Head SAR is mainly determined by whether the receiver is working.
- 2) Body-worn SAR is judged by WIFI state working + the receiver not working
- 3) Hotspot SAR is judged by WIFI hotspot state working + the receiver not working

Description of power reduction scenarios

1) The mobile phone device supports the receiver detection mechanism. This device uses the receiver to indicate whether the user is making a call in head or body.

When there is a voice call (including VOIP) and the audio is actively routed through the earpiece receiver, which indicating the head exposure condition it will trigger the head exposure reduced the power.

When there is a voice call (including VOIP), and the audio is actively routed through the headset or speaker, which indicating the body exposure conditions will trigger the body exposure reduced the power.

When this device used data mode only, and the receiver will not work too, the reduced the power are same as body exposure.

2) The mobile phone device supports the P sensor function.

When the P sensor is turned on + receiving When the device is off and the WIFI is off, it is a 0mm Body SAR power reduction scenario.

WWAN Reduced power level table

Reduced level	Receiver state	P-sensor	Transmitting conditions	Antenna	Power reduced bands
Level 1	On (Head scenario)	neglect	WWAN use only	Ant 4& Ant4	LTE B5 & NR n5 (ENDC)
			WWAN + WLAN 2.4G		
			WWAN + WLAN 5G		
			WWAN + WLAN 5G + BT		
Level 2	Off (Body- worn scenario)	Off (Body- worn scenario)	WWAN use only	Ant 6 & Ant7	LTE B2 & LTE B2 (EN-DC)
Level 3	Off (Body- worn scenario)	Off (Body- worn scenario)	WWAN + WLAN 2.4G	Ant 6 & Ant7	LTE B2 & LTE B2 (EN-DC)
			WWAN + WLAN 5G		
			WWAN + WLAN 5G + BT		
Level 4	Off (Hotspot scenario)	Off (Hotspot scenario)	WWAN + WLAN 2.4G	Ant 6 & Ant7	LTE B2 & LTE B2 (EN-DC)
			WWAN + WLAN 5G		
			WWAN + WLAN 5G + BT		
Level 5	Off (Hotspot scenario)	Off (Hotspot scenario)	WWAN + WLAN 2.4G	Ant 6	LTE 4
			WWAN + WLAN 5G		
			WWAN + WLAN 5G + BT		
Level 6	Off	Off	WWAN + WLAN 2.4G	Ant 6 & Ant7	LTE B66 &



	(Hotspot scenario)	(Hotspot scenario)	WWAN + WLAN 5G + BT	LTE B66 (EN-DC)
			WWAN + WLAN 5G	

WLAN Reduced power level table

Reduced level	Receiver state	P-sensor	Transmitting conditions	Antenna	Power reduced bands
Level 1	On (head scenario)	neglect	WWAN + WLAN 2.4G or WWAN + WLAN 5G	ANT 1	WLAN 2.4G or WLAN 5G
	On (head scenario)		WWAN + WLAN 5G + BT	ANT 1	WLAN 5G or BT
Level 2	Off (body-worn scenario)	Off (body-worn scenario)	WWAN + WLAN 2.4G or WWAN + WLAN5G	ANT 1	WLAN 2.4G or WLAN 5G
	Off (body-worn scenario)	Off (body-worn scenario)	WWAN + WLAN 5G + BT	ANT 1	WLAN 5G or BT
Level 3	Off (Hotspot scenario)	Off (Hotspot scenario)	WWAN +WLAN 2.4G or WWAN + WLAN 5G	ANT 1	WLAN 2.4G or WLAN 5G

Mode	Band	Information	Antenna	Full Power	WWAN Antenna(Tune Up Power)																							
					Head Receiver on				Body-wron Receiver off				Hotspot Receiver off				Product Specific 10-g SAR Sensor on						Sensor off					
					Standalone	+WLAN 2.4G	+WLAN 5G	+WLAN 5G+BT	Standalone	+WLAN 2.4G	+WLAN 5G	+WLAN 5G+BT	Standalone	+WLAN 2.4G	+WLAN 5G	+WLAN 5G+BT	Standalone	+WLAN 2.4G	+WLAN 5G	+WLAN 5G+BT	Standalone	+WLAN 2.4G	+WLAN 5G	+WLAN 5G+BT				
LTE B2	LTE B2	/	Ant 6	25.0	25.0	25.0	25.0	25.0	23.5	23.0	23.0	23.0	19.5	19.5	19.5	19.5	22.5	22.5	22.5	22.5	22.5	22.5	22.5	25.0	23.5	23.5	23.5	
LTE B4	LTE B4	/	Ant 6	25.0	25.0	25.0	25.0	25.0	25.0	25.0	25.0	25.0	22.5	22.5	22.5	22.5	22.5	22.5	22.5	22.5	22.5	22.5	22.5	25.0	25.0	25.0	25.0	
LTE B5	LTE B5	/	Ant 4	25.0	25.0	24.5	24.5	24.5	25.0	25.0	25.0	25.0	25.0	25.0	25.0	25.0	25.0	/	/	/	/	/	/	/	/	/	/	/
LTE B12	LTE B12	/	Ant 4	25.0	25.0	25.0	25.0	25.0	25.0	25.0	25.0	25.0	25.0	25.0	25.0	25.0	25.0	/	/	/	/	/	/	/	/	/	/	/
LTE B13	LTE B13	/	Ant 4	25.0	25.0	25.0	25.0	25.0	25.0	25.0	25.0	25.0	25.0	25.0	25.0	25.0	25.0	/	/	/	/	/	/	/	/	/	/	/
LTE B66	LTE B66	/	Ant 6	25.0	25.0	25.0	25.0	25.0	25.0	25.0	25.0	25.0	23.5	23.5	23.5	23.5	23.5	23.5	23.5	23.5	23.5	23.5	23.5	25.0	25.0	25.0	25.0	
DC_5A_n2	n2	ENDC	Ant 7	25.0	25.0	25.0	25.0	25.0	25.0	25.0	25.0	25.0	25.0	25.0	25.0	25.0	/	/	/	/	/	/	/	/	/	/	/	/
	LTE B5	/	Ant 4	25.0	25.0	24.5	24.5	24.5	25.0	25.0	25.0	25.0	25.0	25.0	25.0	25.0	/	/	/	/	/	/	/	/	/	/	/	/
DC_13A_n2	n2	ENDC	Ant 7	25.0	25.0	25.0	25.0	25.0	25.0	25.0	25.0	25.0	25.0	25.0	25.0	25.0	/	/	/	/	/	/	/	/	/	/	/	/
	LTE B13	/	Ant 4	25.0	25.0	25.0	25.0	25.0	25.0	25.0	25.0	25.0	25.0	25.0	25.0	25.0	/	/	/	/	/	/	/	/	/	/	/	/
DC_66A_n2	n2	ENDC	Ant 7	25.0	25.0	25.0	25.0	25.0	25.0	25.0	25.0	25.0	25.0	25.0	25.0	25.0	/	/	/	/	/	/	/	/	/	/	/	/
	LTE B66	/	Ant 6	25.0	25.0	25.0	25.0	25.0	25.0	25.0	25.0	25.0	23.5	23.5	23.5	23.5	23.5	23.5	23.5	23.5	23.5	23.5	23.5	25.0	25.0	25.0	25.0	
DC_2A_n5	n5	ENDC	Ant 4	25.0	25.0	24.5	24.5	24.5	25.0	25.0	25.0	25.0	25.0	25.0	25.0	25.0	/	/	/	/	/	/	/	/	/	/	/	/
	LTE B2	ENDC	Ant 7	24.0	24.0	24.0	24.0	24.0	23.5	23.5	23.5	23.5	19.5	19.5	19.5	19.5	/	/	/	/	/	/	/	/	/	/	/	/
DC_66A_n5	n5	ENDC	Ant 4	25.0	25.0	24.5	24.5	24.5	25.0	25.0	25.0	25.0	25.0	25.0	25.0	25.0	/	/	/	/	/	/	/	/	/	/	/	/
	LTE B66	ENDC	Ant 7	24.0	24.0	24.0	24.0	24.0	24.0	24.0	24.0	24.0	23.5	23.5	23.5	23.5	/	/	/	/	/	/	/	/	/	/	/	/
DC_2A_n66	n66	ENDC	Ant 7	25.0	25.0	25.0	25.0	25.0	25.0	25.0	25.0	25.0	25.0	25.0	25.0	25.0	/	/	/	/	/	/	/	/	/	/	/	/
	LTE B2	/	Ant 6	25.0	25.0	25.0	25.0	25.0	23.5	23.0	23.0	23.0	19.5	19.5	19.5	19.5	22.5	22.5	22.5	22.5	22.5	22.5	23.5	23.5	23.5	23.5		
DC_5A_n66	n66	ENDC	Ant 7	25.0	25.0	25.0	25.0	25.0	25.0	25.0	25.0	25.0	25.0	25.0	25.0	25.0	/	/	/	/	/	/	/	/	/	/	/	/
	LTE B5	/	Ant 4	25.0	25.0	24.5	24.5	24.5	25.0	25.0	25.0	25.0	25.0	25.0	25.0	25.0	/	/	/	/	/	/	/	/	/	/	/	/
DC_13A_n66	n66	ENDC	Ant 7	25.0	25.0	25.0	25.0	25.0	25.0	25.0	25.0	25.0	25.0	25.0	25.0	25.0	/	/	/	/	/	/	/	/	/	/	/	/
	LTE B13	/	Ant 4	25.0	25.0	25.0	25.0	25.0	25.0	25.0	25.0	25.0	25.0	25.0	25.0	25.0	/	/	/	/	/	/	/	/	/	/	/	/

Power Reduction Configuration

level	Bands	Test position	Sensor Trigger Distance range (DUT to Phantom)	Power reduction amount (dB)	Max Tune up (dBm)
Level 7	LTE B2	Back side	0mm ≤ distance ≤ 9mm	2.5	22.5
Level 2			9mm < distance	1.5	23.5
Level 2		Front side	All	1.5	23.5
Level 2		Left Edge	All	1.5	23.5
Level 7		Right Edge	All	1.5	23.5
Level 2		Top Edge	All	1.5	23.5
Level 7		Bottom Edge	0mm ≤ distance ≤ 9mm	2.5	22.5
Level 2			9mm < distance	1.5	23.5
Level 5		LTE B4	Back side	0mm ≤ distance ≤ 9mm	2.5
Normal	9mm < distance			0	25.0
Normal	Front side		All	0	25.0
Normal	Left Edge		All	0	25.0
Level 5	Right Edge		All	0	25.0
Normal	Top Edge		All	0	25.0
Level 5	Bottom Edge		0mm ≤ distance ≤ 9mm	2.5	22.5
Normal			9mm < distance	0	25.0
Level 6	LTE B66		Back side	0mm ≤ distance ≤ 9mm	1.5
Normal		9mm < distance		0	25.00
Normal		Front side	All	0	25.00
Normal		Left Edge	All	0	25.00
Level 6		Right Edge	All	0	25.00
Normal		Top Edge	All	0	25.00
Level 6		Bottom Edge	0mm ≤ distance ≤ 9mm	1.5	23.50
Normal			9mm < distance	0	25.00

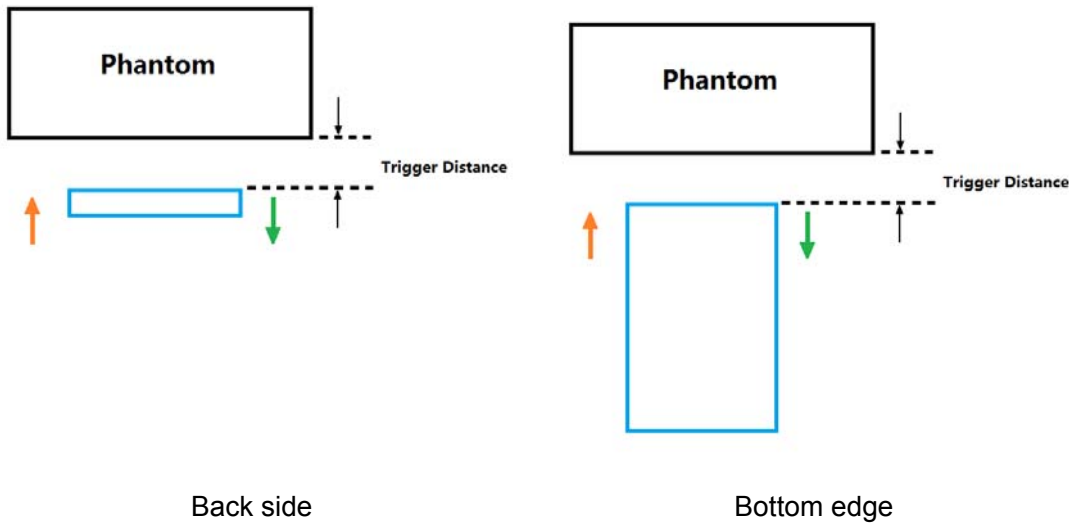

Picture: Proximity sensor triggering distances assessment

Table: Reduced power (Moving toward phantom)

Band	Position	Power Reduction Status(dBm)																												
		29	28	27	26	25	24	23	22	21	20	19	18	17	16	15	14	13	12	11	10	9	8	7	6	5	4	3	2	1
LTE Band 2	Back Side	23.34	23.34	23.34	23.34	23.34	23.34	23.34	23.34	23.34	23.34	23.34	23.34	23.34	23.34	23.34	23.34	23.34	23.34	23.34	22.13	22.13	22.13	22.13	22.13	22.13	22.13	22.13	22.13	22.13
LTE Band 4	Back Side	24.37	24.37	24.37	24.37	24.37	24.37	24.37	24.37	24.37	24.37	24.37	24.37	24.37	24.37	24.37	24.37	24.37	24.37	24.37	22.31	22.31	22.31	22.31	22.31	22.31	22.31	22.31	22.31	22.31
LTE Band 66	Back Side	24.19	24.19	24.19	24.19	24.19	24.19	24.19	24.19	24.19	24.19	24.19	24.19	24.19	24.19	24.19	24.19	24.19	24.19	24.19	23.07	23.07	23.07	23.07	23.07	23.07	23.07	23.07	23.07	23.07

Band	Position	Power Reduction Status(dBm)																												
		29	28	27	26	25	24	23	22	21	20	19	18	17	16	15	14	13	12	11	10	9	8	7	6	5	4	3	2	1
LTE Band 2	Bottom Edge	23.34	23.34	23.34	23.34	23.34	23.34	23.34	23.34	23.34	23.34	23.34	23.34	23.34	23.34	23.34	23.34	23.34	23.34	23.34	22.13	22.13	22.13	22.13	22.13	22.13	22.13	22.13	22.13	22.13
LTE Band 4	Bottom Edge	24.37	24.37	24.37	24.37	24.37	24.37	24.37	24.37	24.37	24.37	24.37	24.37	24.37	24.37	24.37	24.37	24.37	24.37	24.37	22.31	22.31	22.31	22.31	22.31	22.31	22.31	22.31	22.31	22.31
LTE Band 66	Bottom Edge	24.19	24.19	24.19	24.19	24.19	24.19	24.19	24.19	24.19	24.19	24.19	24.19	24.19	24.19	24.19	24.19	24.19	24.19	24.19	23.07	23.07	23.07	23.07	23.07	23.07	23.07	23.07	23.07	23.07

Table: Full power (Moving away from phantom)

Band	Position	Power Reduction Status(dBm)																												
		1	2	3	4	5	6	7	8	9	10	11	12	13	14	15	16	17	18	19	20	21	22	23	24	25	26	27	28	29
LTE Band 2	Back Side	22.13	22.13	22.13	22.13	22.13	22.13	22.13	22.13	22.13	22.13	22.13	22.13	22.13	22.13	22.13	22.13	22.13	22.13	22.13	23.34	23.34	23.34	23.34	23.34	23.34	23.34	23.34	23.34	23.34
LTE Band 4	Back Side	22.31	22.31	22.31	22.31	22.31	22.31	22.31	22.31	22.31	22.31	22.31	22.31	22.31	22.31	22.31	22.31	22.31	22.31	22.31	24.37	24.37	24.37	24.37	24.37	24.37	24.37	24.37	24.37	24.37
LTE Band 66	Back Side	23.07	23.07	23.07	23.07	23.07	23.07	23.07	23.07	23.07	23.07	23.07	23.07	23.07	23.07	23.07	23.07	23.07	23.07	23.07	24.19	24.19	24.19	24.19	24.19	24.19	24.19	24.19	24.19	24.19

Band	Position	Power Reduction Status(dBm)																												
		1	2	3	4	5	6	7	8	9	10	11	12	13	14	15	16	17	18	19	20	21	22	23	24	25	26	27	28	29
LTE Band 2	Bottom Edge	22.13	22.13	22.13	22.13	22.13	22.13	22.13	22.13	22.13	22.13	22.13	22.13	22.13	22.13	22.13	22.13	22.13	22.13	22.13	23.34	23.34	23.34	23.34	23.34	23.34	23.34	23.34	23.34	23.34
LTE Band 4	Bottom Edge	22.31	22.31	22.31	22.31	22.31	22.31	22.31	22.31	22.31	22.31	22.31	22.31	22.31	22.31	22.31	22.31	22.31	22.31	22.31	24.37	24.37	24.37	24.37	24.37	24.37	24.37	24.37	24.37	24.37
LTE Band 66	Bottom Edge	23.07	23.07	23.07	23.07	23.07	23.07	23.07	23.07	23.07	23.07	23.07	23.07	23.07	23.07	23.07	23.07	23.07	23.07	23.07	24.19	24.19	24.19	24.19	24.19	24.19	24.19	24.19	24.19	24.19

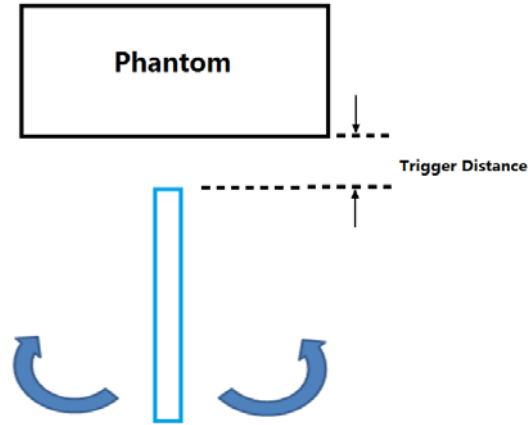

Picture: Proximity sensor tilt angle assessment

Table: Summary of Mobile phone Tilt Angle Influence to Proximity Sensor Triggering (Bottom side)

Band	Minimum trigger distance at which power reduction was maintained over $\pm 45^\circ$	Sensor Power Reduction Status											
		-45°	-35°	-25°	-15°	-5°	0°	5°	15°	25°	35°	45°	
LTE Band 2	9 mm	on	on	on	on	on	on	on	on	on	on	on	on
LTE Band 4	9 mm	on	on	on	on	on	on	on	on	on	on	on	on
LTE Band 66	9 mm	on	on	on	on	on	on	on	on	on	on	on	on

6 SAR Measurements System Configuration

6.1 SAR Measurement Set-up

The DASY system for performing compliance tests consists of the following items:

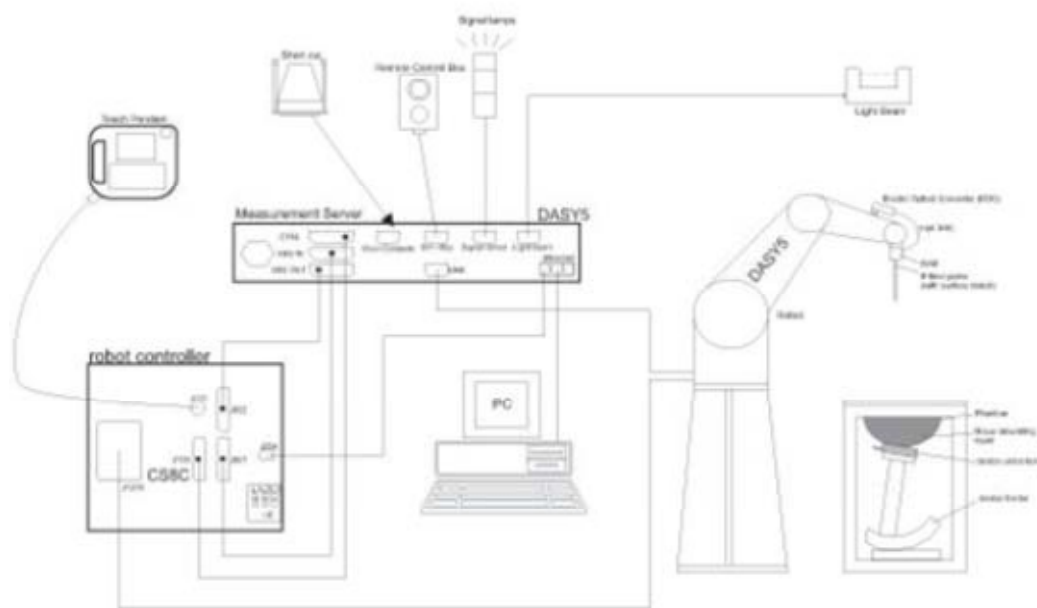

- A standard high precision 6-axis robot with controller, teach pendant and software. An arm extension for accommodating the data acquisition electronics (DAE).
- An isotropic Field probe optimized and calibrated for the targeted measurement.
- A data acquisition electronics (DAE) which performs the signal amplification, signal multiplexing, AD-conversion, offset measurements, mechanical surface detection, collision detection, etc. The unit is battery powered with standard or rechargeable batteries. The signal is optically transmitted to the EOC.
- The Electro-optical converter (EOC) performs the conversion from optical to electrical signals for the digital communication to the DAE. To use optical surface detection, a special version of the EOC is required. The EOC signal is transmitted to the measurement server.
- The function of the measurement server is to perform the time critical tasks such as signal filtering, control of the robot operation and fast movement interrupts.
- The Light Beam used is for probe alignment. This improves the (absolute) accuracy of the probe positioning.
- A computer running WinXP or Win7 and the DASY software.
- Remote control and teach pendant as well as additional circuitry for robot safety such as warning lamps, etc.
- The phantom, the device holder and other accessories according to the targeted measurement.

6.2 DASY5 E-field Probe System

The SAR measurements were conducted with the dosimetric probe EX3DV4 (manufactured by SPEAG), designed in the classical triangular configuration and optimized for dosimetric evaluation.

EX3DV4 Probe Specification

Construction	Symmetrical design with triangular core Built-in shielding against static charges PEEK enclosure material (resistant to organic solvents, e.g., DGBE)
Calibration	ISO/IEC 17025 calibration service available
Frequency	10 MHz to > 6 GHz Linearity: ± 0.2 dB (30 MHz to 6 GHz)
Directivity	± 0.3 dB in HSL (rotation around probe axis) ± 0.5 dB in tissue material (rotation normal to probe axis)
Dynamic Range	10 μ W/g to > 100 mW/g Linearity: ± 0.2 dB (noise: typically < 1 μ W/g)
Dimensions	Overall length: 330 mm (Tip: 20 mm) Tip diameter: 2.5 mm (Body: 12 mm) Typical distance from probe tip to dipole centers: 1 mm
Application	High precision dosimetric measurements in any exposure Scenario (e.g., very strong gradient fields). Only probe which enables compliance testing for frequencies up to 6 GHz with precision of better 30%.



E-field Probe Calibration

Each probe is calibrated according to a dosimetric assessment procedure with accuracy better than $\pm 10\%$. The spherical isotropy was evaluated and found to be better than ± 0.25 dB. The sensitivity parameters (NormX, NormY, NormZ), the diode compression parameter (DCP) and the conversion factor (ConvF) of the probe are tested.

The free space E-field from amplified probe outputs is determined in a test chamber. This is performed in a TEM cell for frequencies below 1 GHz, and in a wave guide above 1 GHz for free space. For the free space calibration, the probe is placed in the volumetric center of the cavity and at the proper orientation with the field. The probe is then rotated 360 degrees.

E-field temperature correlation calibration is performed in a flat phantom filled with the appropriate simulated brain tissue. The measured free space E-field in the medium correlates to temperature rise in a dielectric medium. For temperature correlation calibration a RF transparent thermistor-based



temperature probe is used in conjunction with the E-field probe.

$$\text{SAR} = C \Delta T / \Delta t$$

Where: Δt = Exposure time (30 seconds),

C = Heat capacity of tissue (brain or muscle),

ΔT = Temperature increase due to RF exposure.

Or

$$\text{SAR} = |E|^2 \sigma / \rho$$

Where: σ = Simulated tissue conductivity,

ρ = Tissue density (kg/m^3).

6.3 SAR Measurement Procedure

Power Reference Measurement

The Power Reference Measurement and Power Drift Measurements are for monitoring the power drift of the device under test in the batch process. The minimum distance of probe sensors to surface determines the closest measurement point to phantom surface. This distance cannot be smaller than the distance of sensor calibration points to probe tip as defined in the probe properties.

Area Scan

The area scan is used as a fast scan in two dimensions to find the area of high field values, before doing a fine measurement around the hot spot. The sophisticated interpolation routines implemented in DASY software can find the maximum found in the scanned area, within a range of the global maximum. The range (in dB) is specified in the standards for compliance testing. For example, a 2 dB range is required in IEEE standard 1528 and IEC 62209 standards, whereby 3 dB is a requirement when compliance is assessed in accordance with the ARIB standard (Japan), if only one zoom scan follows the area scan, then only the absolute maximum will be taken as reference. For cases where multiple maximums are detected, the number of zoom scans has to be increased accordingly.

Area scan parameters extracted from FCC KDB 865664 D01 SAR measurement 100 MHz to 6 GHz.

	≤ 3 GHz	> 3 GHz
Maximum distance from closest measurement point (geometric center of probe sensors) to phantom surface	5 ± 1 mm	$\frac{1}{2} \cdot \delta \cdot \ln(2) \pm 0.5 \text{ mm}$
Maximum probe angle from probe axis to phantom surface normal at the measurement location	30° ± 1°	20° ± 1°
Maximum area scan spatial resolution: $\Delta x_{\text{Area}}, \Delta y_{\text{Area}}$	≤ 2 GHz: ≤ 15 mm 2 – 3 GHz: ≤ 12 mm	3 – 4 GHz: ≤ 12 mm 4 – 6 GHz: ≤ 10 mm
	When the x or y dimension of the test device, in the measurement plane orientation, is smaller than the above, the measurement resolution must be ≤ the corresponding x or y dimension of the test device with at least one measurement point on the test device.	

Zoom Scan

Zoom scans are used to assess the peak spatial SAR values within a cubic averaging volume containing 1 gram and 10 gram of simulated tissue. The zoom scan measures points (refer to table below) within a cube whose base faces are centered on the maxima found in a preceding area scan job within the same procedure. When the measurement is done, the zoom scan evaluates the averaged SAR for 1 gram and 10 gram and displays these values next to the job's label.

Zoom scan parameters extracted from FCC KDB 865664 D01 SAR measurement 100 MHz to 6 GHz.

			≤3GHz	> 3 GHz
Maximum zoom scan spatial resolution: $\Delta x_{zoom} \Delta y_{zoom}$			≤2GHz: ≤8mm 2 – 3GHz: ≤5mm*	3 – 4GHz: ≤5mm* 4 – 6GHz: ≤4mm*
Maximum zoom scan spatial resolution, normal to phantom surface	Uniform grid: $\Delta z_{zoom}(n)$		≤5mm	3 – 4GHz: ≤4mm 4 – 5GHz: ≤3mm 5 – 6GHz: ≤2mm
	Graded grid	$\Delta z_{zoom}(1)$: between 1 st two points closest to phantom surface	≤4mm	3 – 4GHz: ≤3mm 4 – 5GHz: ≤2.5mm 5 – 6GHz: ≤2mm
		$\Delta z_{zoom}(n > 1)$: between subsequent points	≤1.5 • $\Delta z_{zoom}(n-1)$	
Minimum zoom scan volume	X, y, z		≥30mm	3 – 4GHz: ≥28mm 4 – 5GHz: ≥25mm 5 – 6GHz: ≥22mm
<p>Note: δ is the penetration depth of a plane-wave at normal incidence to the tissue medium; see draft standard IEEE P1528-2011 for details.</p> <p>* When zoom scan is required and the <u>reported</u> SAR from the <i>area scan based 1-g SAR estimation</i> procedures of KDB 447498 is ≤ 1.4W/kg, ≤8mm, ≤7mm and ≤5mm zoom scan resolution may be applied, respectively, for 2GHz to 3GHz, 3GHz to 4GHz and 4GHz to 6GHz.</p>				

Volume Scan Procedures

The volume scan is used to assess overlapping SAR distributions for antennas transmitting in different frequency bands. It is equivalent to an oversized zoom scan used in standalone measurements. The measurement volume will be used to enclose all the simultaneous transmitting antennas. For antennas transmitting simultaneously in different frequency bands, the volume scan is measured separately in each frequency band. In order to sum correctly to compute the 1g aggregate SAR, the EUT remain in the same test position for all measurements and all volume scan use the same spatial resolution and grid spacing. When all volume scan were completed, the software, SEMCAD postprocessor can combine and subsequently superpose these measurement data to calculating the multiband SAR.

Power Drift Monitoring

All SAR testing is under the EUT install full charged battery and transmit maximum output power. In DASYS measurement software, the power reference measurement and power drift measurement procedures are used for monitoring the power drift of EUT during SAR test. Both these procedures measure the field at a specified reference position before and after the SAR testing. The software will calculate the field difference in dB. If the power drifts more than 5%, the SAR will be retested.



7 Main Test Equipment

Name of Equipment	Manufacturer	Type/Model	Serial Number	Last Cal.	Cal. Due Date
Network analyzer	Agilent	E5071B	MY42404014	2020-05-17	2021-05-16
Dielectric Probe Kit	HP	85070E	US44020115	2020-05-17	2021-05-16
Power meter	Agilent	E4417A	GB41291714	2020-05-17	2021-05-16
Power sensor	Agilent	N8481H	MY50350004	2020-05-17	2021-05-16
Power sensor	Agilent	E9327A	US40441622	2020-05-17	2021-05-16
Dual directional coupler	Agilent	778D-012	50519	/	/
Dual directional coupler	Agilent	777D	50146	/	/
Dual directional coupler	UCL	UCL-DDC0 56G-S	20010600118	/	/
Amplifier	INDEXSAR	IXA-020	0401	2020-05-17	2021-05-16
Wireless communication tester	Anritsu	MT8820C	6201342015	2020-05-17	2021-05-16
Wideband radio communication tester	R&S	CMW 500	113645	2020-05-17	2021-05-16
Base Station Simulator	R&S	CMW270	100673	2020-05-17	2021-05-16
E-field Probe	SPEAG	EX3DV4	3677	2020-07-06	2021-07-05
DAE	SPEAG	DAE4	1317	2019-10-23	2020-10-22
Validation Kit 750MHz	SPEAG	D750V3	1045	2020-08-28	2023-08-27
Validation Kit 835MHz	SPEAG	D835V2	4d020	2020-08-28	2023-08-27
Validation Kit 1750MHz	SPEAG	D1750V2	1033	2020-02-25	2023-02-24
Validation Kit 1900MHz	SPEAG	D1900V2	5d060	2020-08-27	2023-08-26
Validation Kit 2450MHz	SPEAG	D2450V2	786	2020-08-27	2023-08-26
Validation Kit 5GHz	SPEAG	D5GHzV2	1151	2020-02-27	2023-02-26
Temperature Probe	Tianjin jinming	JM222	381	2020-05-25	2021-05-24
Hygrothermograph	Anymetr	HTC-1	TY2020A043	2020-05-19	2021-05-18
Twin SAM Phantom	Speag	SAM1	1534	/	/
Software for Test	Speag	DASY52	/	/	/
Softwarefor Tissue	Agilent	85070	/	/	/

8 Tissue Dielectric Parameter Measurements & System Verification

8.1 Tissue Verification

The temperature of the tissue-equivalent medium used during measurement must also be within 18°C to 25°C and within ± 2°C of the temperature when the tissue parameters are characterized. The dielectric parameters must be measured before the tissue-equivalent medium is used in a series of SAR measurements. The parameters should be re-measured after each 24 hours of use; or earlier if the dielectric parameters can become out of tolerance.

Target values

Frequency (MHz)	Water (%)	Salt (%)	Sugar (%)	Glycol (%)	Preventol (%)	Cellulose (%)	ϵ_r	σ (s/m)
750	41.448	1.452	56	0	0.1	1.0	41.9	0.89
835	41.45	1.45	56	0	0.1	1.0	41.5	0.90
1750	55.24	0.31	0	44.45	0	0	40.1	1.37
1900	55.242	0.306	0	44.452	0	0	40.0	1.40
2450	62.7	0.5	0	36.8	0	0	39.2	1.80
Frequency (MHz)	Water (%)	Diethylenglycol mono-hexylether			Triton X-100		ϵ_r	σ (s/m)
5250	65.53	17.24			17.23		35.9	4.71
5750	65.53	17.24			17.23		35.4	5.22

Measurements results

Frequency (MHz)	Test Date	Temp °C	Measured Dielectric Parameters		Target Dielectric Parameters		Limit (Within ±5%)	
			ϵ_r	σ (s/m)	ϵ_r	σ (s/m)	Dev ϵ_r (%)	Dev σ (%)
750	8/25/2020	21.5	42.3	0.88	41.9	0.89	0.95	-1.12
835	10/15/2020	21.5	41.4	0.88	41.5	0.90	-0.24	-2.22
	10/16/2020	21.5	41.3	0.87	41.5	0.90	-0.48	-3.33
	10/17/2020	21.5	41.4	0.92	41.5	0.90	-0.24	2.22
1750	9/22/2020	21.5	40.2	1.34	40.1	1.37	0.25	-2.19
	9/25/2020	21.5	40.1	1.35	40.1	1.37	0.00	-1.46
	8/28/2020	21.5	40.0	1.36	40.1	1.37	-0.25	-0.73
1900	9/3/2020	21.5	40.1	1.41	40.0	1.40	0.25	0.71
	9/4/2020	21.5	40.2	1.43	40.0	1.40	0.50	2.14
2450	9/10/2020	21.5	38.9	1.81	39.2	1.80	-0.77	0.56
5250	10/9/2020	21.5	35.5	4.80	35.9	4.71	-1.11	1.91
5750	10/11/2020	21.5	34.9	5.21	35.4	5.22	-1.41	-0.19

Note: The depth of tissue-equivalent liquid in a phantom must be ≥ 15.0 cm for SAR measurements ≤ 3 GHz and ≥ 10.0 cm for measurements > 3 GHz.

8.2 System Performance Check

The manufacturer calibrates the probes annually. Dielectric parameters of the tissue simulates were measured using the dielectric probe kit and the network analyzer. A system check measurement for every day was made following the determination of the dielectric parameters of the Tissue simulates, using the dipole validation kit. The dipole antenna was placed under the flat section of the twin SAM phantom.

System check is performed regularly on all frequency bands where tests are performed with the DASY system.

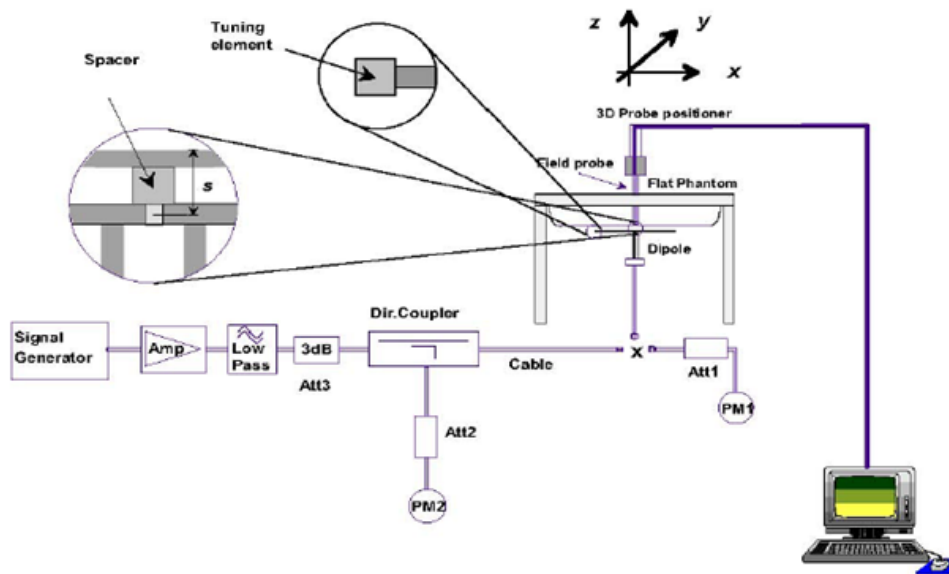

Picture 1 System Performance Check setup



Picture 2 Setup Photo

**Justification for Extended SAR Dipole Calibrations**

Usage of SAR dipoles calibrated less than 3 years ago but more than 1 year ago were confirmed in maintaining return loss (< -20 dB, within 20% of prior calibration) and impedance (within 5 ohm from prior calibration) requirements per extended calibrations in KDB 865664 D01:

Dipole		Date of Measurement	Return Loss(dB)	Δ %	Impedance (Ω)	$\Delta\Omega$
Dipole D750V3 SN: 1045	Head Liquid	8/27/2017	-28.5	/	52.5	/
		8/26/2018	-27.6	3.3	53.2	-0.7
		8/25/2019	-27.5	0.4	54.1	-0.9
Dipole D835V2 SN: 4d020	Head Liquid	8/28/2017	-31.9	/	50.3	/
		8/27/2018	-29.0	10.0	46.6	3.7
		8/26/2019	-29.4	-1.4	45.9	0.7
Dipole D1900V2 SN: 5d060	Head Liquid	8/26/2017	-23.4	/	52.0	/
		8/25/2018	-24.7	-5.3	54.4	-2.4
		8/24/2019	-24.9	-0.8	56.2	-1.8
Dipole D2450V2 SN: 786	Head Liquid	8/29/2017	-25.5	/	53.4	/
		8/28/2018	-23.0	10.9	57.2	-3.8
		8/27/2019	-22.2	3.6	56.4	0.8

System Check results

Frequency (MHz)	Test Date	Temp $^{\circ}\text{C}$	250mW /100mW Measured SAR _{1g} (W/kg)	1W Normalized SAR _{1g} (W/kg)	1W Target SAR _{1g} (W/kg)	Δ % (Limit $\pm 10\%$)	Plot No.
750	8/25/2020	21.5	2.20	8.80	8.37	5.14	1
835	10/15/2020	21.5	2.46	9.84	9.65	1.97	2
	10/16/2020	21.5	2.45	9.80	9.65	1.55	3
	10/17/2020	21.5	2.44	9.76	9.65	1.14	4
1750	9/22/2020	21.5	8.95	35.80	35.90	-0.28	5
	9/25/2020	21.5	9.11	36.44	35.90	1.50	6
	8/28/2020	21.5	8.96	35.84	35.90	-0.17	7
1900	9/3/2020	21.5	9.86	39.44	39.50	-0.15	8
	9/4/2020	21.5	9.82	39.28	39.50	-0.56	9
2450	9/10/2020	21.5	13.73	54.92	52.30	5.01	10
5250	10/9/2020	21.5	7.86	78.60	78.00	0.77	11
5750	10/9/2020	21.5	7.68	76.80	77.40	-0.78	12

Note: Target Values used derive from the calibration certificate Data Storage and Evaluation.



8.3 SAR System Validation

Per FCC KDB 865664 D02v01, SAR system verification is required to confirm measurement accuracy. The SAR systems (including SAR probes, system components and software versions) used for this device were validated against its performance specifications prior to the SAR measurements. Reference dipoles are used with the required tissue-equivalent media for system validation, according to the procedures outlined in FCC KDB 865664 D01 and IEEE 1528-2013. Since SAR probe calibrations are frequency dependent, each probe calibration point must be validated at a frequency within the valid frequency range of the probe calibration point, using the system that normally operates with the probe for routine SAR measurements and according to the required tissue-equivalent media.

a tabulated summary of the system validation status, measurement frequencies, SAR probes, calibrated signal type(s) and tissue dielectric parameters has been included.

Frequency [MHz]	Date	Probe SN	Probe Type	Probe Cal Point		PERM (Er)	COND (Σ)	CW Validation			Mod. Validation		
								Sensitivity	Probe Linearity	Probe Isotropy	Mod. Type	Duty Factor	PAR
750	7/6/2020	3677	EX3DV4	750	Head	42.81	0.85	PASS	PASS	PASS	FDD	PASS	N/A
835	7/6/2020	3677	EX3DV4	835	Head	42.22	0.90	PASS	PASS	PASS	GMSK	PASS	N/A
1750	7/6/2020	3677	EX3DV4	1750	Head	39.91	1.32	PASS	PASS	PASS	NA	N/A	N/A
1900	7/6/2020	3677	EX3DV4	1900	Head	39.43	1.42	PASS	PASS	PASS	GMSK	PASS	N/A
2450	7/6/2020	3677	EX3DV4	2450	Head	38.19	1.83	PASS	PASS	PASS	OFDM	PASS	PASS
2600	7/6/2020	3677	EX3DV4	2600	Head	37.60	1.99	PASS	PASS	PASS	TDD	PASS	N/A
5250	7/6/2020	3677	EX3DV4	5250	Head	35.36	4.83	PASS	PASS	PASS	OFDM	N/A	PASS
5600	7/6/2020	3677	EX3DV4	5600	Head	34.43	5.29	PASS	PASS	PASS	OFDM	N/A	PASS
5750	7/6/2020	3677	EX3DV4	5750	Head	34.07	5.47	PASS	PASS	PASS	OFDM	N/A	PASS
750	7/6/2020	3677	EX3DV4	750	Body	55.35	0.99	PASS	PASS	PASS	FDD	PASS	N/A
835	7/6/2020	3677	EX3DV4	835	Body	54.88	0.98	PASS	PASS	PASS	GMSK	PASS	N/A
1750	7/6/2020	3677	EX3DV4	1750	Body	51.24	1.44	PASS	PASS	PASS	NA	N/A	N/A
1900	7/6/2020	3677	EX3DV4	1900	Body	50.98	1.56	PASS	PASS	PASS	GMSK	PASS	N/A
2450	7/6/2020	3677	EX3DV4	2450	Body	50.59	1.95	PASS	PASS	PASS	OFDM	PASS	PASS
2600	7/6/2020	3677	EX3DV4	2600	Body	50.14	2.13	PASS	PASS	PASS	TDD	PASS	N/A
5250	7/6/2020	3677	EX3DV4	5250	Body	47.37	5.44	PASS	PASS	PASS	OFDM	N/A	PASS
5600	7/6/2020	3677	EX3DV4	5600	Body	46.42	5.99	PASS	PASS	PASS	OFDM	N/A	PASS
5750	7/6/2020	3677	EX3DV4	5750	Body	46.02	6.23	PASS	PASS	PASS	OFDM	N/A	PASS

NOTE: While the probes have been calibrated for both CW and modulated signals, all measurements were performed using communication systems calibrated for CW signals only. Modulations in the table above represent test configurations for which the measurement system has been validated per FCC KDB Publication 865664D01v01 for scenarios when CW probe calibrations are used with other signal types. SAR systems were validated for modulated signals with a periodic duty cycle, such as GMSK, or with a high peak to average ratio (>5dB), such as OFDM according to KDB 865664.

9 Normal and Maximum Output Power

KDB 447498 D01 at the maximum rated output power and within the tune-up tolerance range specified for the product, but not more than 2 dB lower than the maximum tune-up tolerance limit.

9.1 LTE Mode

UE Power Class: 3 (23 +/- 2dBm). The allowed Maximum Power Reduction (MPR) for the maximum output power due to higher order modulation and transmit bandwidth configuration (resource blocks) is specified in Table 6.2.3-1 of the 3GPP TS36.101.

Table 6.2.3-1: Maximum Power Reduction (MPR) for Power Class 3

Modulation	Channel bandwidth / Transmission bandwidth (N _{RB})						MPR (dB)
	1.4 MHz	3.0 MHz	5 MHz	10 MHz	15 MHz	20 MHz	
QPSK	> 5	> 4	> 8	> 12	> 16	> 18	≤ 1
16 QAM	≤ 5	≤ 4	≤ 8	≤ 12	≤ 16	≤ 18	≤ 1
16 QAM	> 5	> 4	> 8	> 12	> 16	> 18	≤ 2
64 QAM	≤ 5	≤ 4	≤ 8	≤ 12	≤ 16	≤ 18	≤ 2
64 QAM	> 5	> 4	> 8	> 12	> 16	> 18	≤ 3

LTE Antenna Configuration

	Band	Antenna 4	Antenna 6	Antenna 7
LTE	FDD 2	--	TRX	--
	FDD 4	--	TRX	--
	FDD 5	TRX	--	--
	FDD 12	TRX	--	--
	FDD 13	TRX	--	--
	FDD 66			TRX

LTE FDD Band 2-Antenna 6 Normal Power				Conducted Power(dBm)			Tune-up Limit
Bandwidth	Modulation	RB size	RB offset	Channel/Frequency (MHz)			
				18607/1850.7	18900/1880	19193/1909.3	
1.4MHz	QPSK	1	0	24.21	24.28	24.26	25.00
		1	2	24.17	24.19	24.15	25.00
		1	5	24.10	24.12	24.23	25.00
		3	0	24.23	24.35	24.26	25.00
		3	2	24.35	24.35	24.42	25.00
		3	3	24.46	24.29	24.41	25.00
	6	0	23.33	23.32	23.28	24.00	
	16QAM	1	0	23.12	23.52	23.57	24.00
1		2	23.10	23.45	23.46	24.00	



		1	5	23.25	23.58	23.64	24.00
		3	0	22.90	23.19	23.25	24.00
		3	2	22.89	23.19	23.24	24.00
		3	3	23.02	23.35	23.38	24.00
		6	0	21.93	22.24	22.26	23.00
	64QAM	1	0	23.08	23.40	23.61	24.00
		1	2	23.17	23.51	23.58	24.00
		1	5	22.98	23.33	23.33	24.00
		3	0	22.87	23.19	23.25	24.00
		3	2	22.92	23.23	23.31	24.00
		3	3	22.99	23.32	23.34	24.00
		6	0	21.94	22.28	22.33	23.00
	Bandwidth	Modulation	RB size	RB offset	Channel/Frequency (MHz)		
18615/1851.5					18900/1880	19185/1908.5	
3MHz	QPSK	1	0	24.23	24.32	24.29	25.00
		1	7	24.15	24.22	24.19	25.00
		1	14	24.13	24.17	24.27	25.00
		8	0	23.33	23.47	23.39	24.00
		8	4	23.47	23.45	23.54	24.00
		8	7	23.56	23.40	23.51	24.00
		15	0	23.33	23.36	23.31	24.00
	16QAM	1	0	23.15	23.54	23.60	24.00
		1	7	23.13	23.45	23.50	24.00
		1	14	23.27	23.62	23.67	24.00
		8	0	22.01	22.32	22.37	23.00
		8	4	22.00	22.32	22.36	23.00
		8	7	22.12	22.47	22.51	23.00
		15	0	21.96	22.28	22.29	23.00
	64QAM	1	0	23.11	23.42	23.64	24.00
		1	7	23.20	23.51	23.60	24.00
		1	14	23.00	23.32	23.36	24.00
		8	0	21.98	22.32	22.37	23.00
		8	4	22.03	22.36	22.43	23.00
		8	7	22.09	22.44	22.47	23.00
		15	0	21.97	22.32	22.36	23.00
Bandwidth	Modulation	RB size	RB offset	Channel/Frequency (MHz)			Tune-up Limit
				18625/1852.5	18900/1880	19175/1907.5	
5MHz	QPSK	1	0	24.20	24.30	24.25	25.00
		1	13	24.13	24.18	24.16	25.00
		1	24	24.10	24.12	24.23	25.00
		12	0	23.30	23.42	23.35	24.00
		12	6	23.45	23.41	23.49	24.00
		12	13	23.54	23.38	23.47	24.00



	16QAM	25	0	23.33	23.35	23.29	24.00
		1	0	23.12	23.50	23.57	24.00
		1	13	23.10	23.43	23.47	24.00
		1	24	23.24	23.60	23.63	24.00
		12	0	21.99	22.28	22.34	23.00
		12	6	21.97	22.27	22.32	23.00
		12	13	22.09	22.42	22.47	23.00
		25	0	21.94	22.24	22.24	23.00
	64QAM	1	0	23.08	23.42	23.61	24.00
		1	13	23.17	23.53	23.57	24.00
		1	24	23.01	23.30	23.32	24.00
		12	0	21.96	22.28	22.38	23.00
		12	6	22.00	22.31	22.39	23.00
		12	13	22.06	22.39	22.43	23.00
		25	0	21.95	22.28	22.31	23.00
Bandwidth	Modulation	RB size	RB offset	Channel/Frequency (MHz)			Tune-up Limit
				18650/1855	18900/1880	19150/1905	
10MHz	QPSK	1	0	24.22	24.31	24.28	25.00
		1	25	24.16	24.23	24.20	25.00
		1	49	24.12	24.16	24.26	25.00
		25	0	23.33	23.47	23.39	24.00
		25	13	23.48	23.46	23.53	24.00
		25	25	23.56	23.42	23.52	24.00
		50	0	23.37	23.37	23.33	24.00
	16QAM	1	0	23.14	23.53	23.59	24.00
		1	25	23.13	23.47	23.50	24.00
		1	49	23.27	23.62	23.66	24.00
		25	0	22.02	22.33	22.38	23.00
		25	13	21.99	22.31	22.35	23.00
		25	25	22.12	22.47	22.51	23.00
		50	0	21.97	22.29	22.28	23.00
	64QAM	1	0	23.10	23.41	23.63	24.00
		1	25	23.20	23.53	23.60	24.00
		1	49	23.00	23.32	23.35	24.00
		25	0	21.99	22.33	22.38	23.00
		25	13	22.02	22.35	22.42	23.00
		25	25	22.09	22.44	22.47	23.00
		50	0	21.98	22.33	22.35	23.00
Bandwidth	Modulation	RB size	RB offset	Channel/Frequency (MHz)			Tune-up Limit
				18675/1857.5	18900/1880	19125/1902.5	
15MHz	QPSK	1	0	24.21	24.27	24.26	25.00
		1	38	24.14	24.22	24.17	25.00
		1	74	24.09	24.11	24.22	25.00



		36	0	23.31	23.43	23.36	24.00	
		36	18	23.45	23.41	23.49	24.00	
		36	39	23.53	23.39	23.48	24.00	
		75	0	23.35	23.33	23.28	24.00	
	16QAM	1	0	23.09	23.51	23.57	24.00	
		1	38	23.11	23.44	23.48	24.00	
		1	74	23.24	23.58	23.42	24.00	
		36	0	21.99	22.31	22.35	23.00	
		36	18	21.96	22.26	22.31	23.00	
		36	39	22.10	22.43	22.48	23.00	
		75	0	21.94	22.24	22.24	23.00	
	64QAM	1	0	23.05	23.39	23.61	24.00	
		1	38	23.18	23.50	23.37	24.00	
		1	74	23.01	23.31	23.36	24.00	
		36	0	21.98	22.35	22.39	23.00	
		36	18	22.00	22.32	22.41	23.00	
		36	39	22.07	22.40	22.44	23.00	
		75	0	21.95	22.28	22.31	23.00	
	Bandwidth	Modulation	RB size	RB offset	Channel/Frequency (MHz)			Tune-up Limit
					18700/1860	18900/1880	19100/1900	
	20MHz	QPSK	1	0	24.18	24.23	24.23	25.00
1			50	24.13	24.18	24.15	25.00	
1			99	24.07	24.10	24.19	25.00	
50			0	23.28	23.38	23.32	24.00	
50			25	23.43	23.37	23.46	24.00	
50			50	23.50	23.34	23.44	24.00	
100			0	23.32	23.28	23.24	24.00	
16QAM		1	0	23.19	23.47	23.52	24.00	
		1	50	23.07	23.42	23.44	24.00	
		1	99	23.22	23.55	23.61	24.00	
		50	0	21.96	22.27	22.32	23.00	
		50	25	21.93	22.24	22.28	23.00	
		50	50	22.07	22.38	22.44	23.00	
		100	0	21.92	22.20	22.21	23.00	
64QAM		1	0	23.03	23.35	23.56	24.00	
		1	50	23.14	23.48	23.54	24.00	
		1	99	22.95	23.25	23.30	24.00	
		50	0	21.93	22.27	22.32	23.00	
		50	25	21.96	22.28	22.35	23.00	
		50	50	22.04	22.35	22.40	23.00	
		100	0	21.93	22.24	22.28	23.00	



LTE FDD Band 2 Level 2				Conducted Power(dBm)			Tune-up Limit
Bandwidth	Modulation	RB size	RB offset	Channel/Frequency (MHz)			
				18607/1850.7	18900/1880	19193/1909.3	
1.4MHz	QPSK	1	0	23.36	23.20	23.21	23.50
		1	2	23.38	23.14	23.15	23.50
		1	5	23.28	23.11	23.18	23.50
		3	0	23.37	23.29	23.14	23.50
		3	2	23.33	23.33	23.34	23.50
		3	3	23.36	23.25	23.34	23.50
		6	0	22.29	22.29	22.29	22.50
	16QAM	1	0	22.37	22.30	22.37	22.50
		1	2	22.35	22.36	22.29	22.50
		1	5	22.37	22.33	22.31	22.50
		3	0	22.22	22.27	22.21	22.50
		3	2	22.35	22.27	22.42	22.50
		3	3	22.31	22.27	22.35	22.50
		6	0	21.27	21.24	21.36	21.50
	64QAM	1	0	22.30	22.32	22.29	22.50
		1	2	22.32	22.36	22.30	22.50
		1	5	22.20	22.36	22.38	22.50
		3	0	22.22	22.22	22.20	22.50
		3	2	22.36	22.12	22.33	22.50
		3	3	22.32	22.41	22.33	22.50
		6	0	21.36	21.30	21.31	21.50
Bandwidth	Modulation	RB size	RB offset	Channel/Frequency (MHz)			Tune-up Limit
				18615/1851.5	18900/1880	19185/1908.5	
3MHz	QPSK	1	0	23.38	23.24	23.24	23.50
		1	7	23.36	23.17	23.19	23.50
		1	14	23.31	23.16	23.22	23.50
		8	0	22.35	22.29	22.27	22.50
		8	4	22.33	22.31	22.34	22.50
		8	7	22.34	22.36	22.32	22.50
		15	0	22.30	22.33	22.32	22.50
	16QAM	1	0	22.35	22.33	22.34	22.50
		1	7	22.32	22.37	22.31	22.50
		1	14	22.29	22.38	22.35	22.50
		8	0	21.33	21.28	21.33	21.50
		8	4	21.34	21.40	21.34	21.50
		8	7	21.29	21.39	21.36	21.50
		15	0	21.31	21.28	21.39	21.50
	64QAM	1	0	22.34	22.35	22.32	22.50
		1	7	22.35	22.37	22.32	22.50



Bandwidth	Modulation	RB size	RB offset	Channel/Frequency (MHz)			Tune-up Limit	
				18625/1852.5	18900/1880	19175/1907.5		
		1	14	22.22	22.35	22.29	22.50	
		8	0	21.33	21.35	21.32	21.50	
		8	4	21.35	21.25	21.33	21.50	
		8	7	21.30	21.36	21.34	21.50	
		15	0	21.39	21.34	21.34	21.50	
5MHz	QPSK	1	0	23.35	23.22	23.20	23.50	
		1	13	23.34	23.13	23.16	23.50	
		1	24	23.28	23.11	23.18	23.50	
		12	0	22.33	22.36	22.23	22.50	
		12	6	22.32	22.39	22.30	22.50	
		12	13	22.33	22.34	22.29	22.50	
		25	0	22.31	22.32	22.30	22.50	
	16QAM	1	0	22.39	22.30	22.34	22.50	
		1	13	22.37	22.36	22.32	22.50	
		1	24	22.38	22.37	22.32	22.50	
		12	0	21.31	21.36	21.30	21.50	
		12	6	21.32	21.35	21.39	21.50	
		12	13	21.38	21.34	21.33	21.50	
		25	0	21.30	21.24	21.34	21.50	
	64QAM	1	0	22.32	22.36	22.29	22.50	
		1	13	22.32	22.40	22.29	22.50	
		1	24	22.23	22.33	22.37	22.50	
		12	0	21.31	21.31	21.33	21.50	
		12	6	21.33	21.20	21.30	21.50	
		12	13	21.28	21.37	21.31	21.50	
		25	0	21.37	21.30	21.29	21.50	
	Bandwidth	Modulation	RB size	RB offset	Channel/Frequency (MHz)			Tune-up Limit
					18650/1855	18900/1880	19150/1905	
	10MHz	QPSK	1	0	23.37	23.23	23.23	23.50
1			25	23.37	23.18	23.20	23.50	
1			49	23.30	23.15	23.21	23.50	
25			0	22.37	22.30	22.27	22.50	
25			13	22.31	22.38	22.34	22.50	
25			25	22.36	22.38	22.35	22.50	
50			0	22.36	22.24	22.24	22.50	
16QAM		1	0	22.36	22.34	22.38	22.50	
		1	25	22.37	22.37	22.36	22.50	
		1	49	22.32	22.35	22.36	22.50	
		25	0	21.24	21.31	21.24	21.50	
		25	13	21.35	21.29	21.37	21.50	
		25	25	21.31	21.29	21.38	21.50	



Bandwidth	Modulation	RB size	RB offset	Channel/Frequency (MHz)			Tune-up Limit	
				18675/1857.5	18900/1880	19125/1902.5		
	64QAM	50	0	21.34	21.29	21.28	21.50	
		1	0	22.35	22.46	22.21	22.50	
		1	25	22.35	22.33	22.32	22.50	
		1	49	22.22	22.35	22.31	22.50	
		25	0	21.34	21.36	21.33	21.50	
		25	13	21.36	21.24	21.34	21.50	
		25	25	21.32	21.31	21.36	21.50	
		50	0	21.30	21.35	21.33	21.50	
15MHz	QPSK	1	0	23.36	23.19	23.21	23.50	
		1	38	23.35	23.17	23.17	23.50	
		1	74	23.27	23.10	23.17	23.50	
		36	0	22.40	22.37	22.24	22.50	
		36	18	22.35	22.39	22.30	22.50	
		36	39	22.34	22.35	22.38	22.50	
		75	0	22.44	22.30	22.29	22.50	
	16QAM	1	0	22.38	22.35	22.38	22.50	
		1	38	22.32	22.30	22.35	22.50	
		1	74	22.35	22.31	22.43	22.50	
		36	0	21.31	21.39	21.31	21.50	
		36	18	21.42	21.34	21.38	21.50	
		36	39	21.39	21.35	21.45	21.50	
		75	0	21.37	21.24	21.34	21.50	
	64QAM	1	0	22.40	22.35	22.29	22.50	
		1	38	22.33	22.36	22.30	22.50	
		1	74	22.23	22.34	22.27	22.50	
		36	0	21.33	21.38	21.34	21.50	
		36	18	21.27	21.21	21.34	21.50	
		36	39	21.40	21.32	21.36	21.50	
		75	0	21.37	21.30	21.29	21.50	
	Bandwidth	Modulation	RB size	RB offset	Channel/Frequency (MHz)			Tune-up Limit
					18700/1860	18900/1880	19100/1900	
	20MHz	QPSK	1	0	23.33	23.15	23.18	23.50
1			50	23.34	23.13	23.15	23.50	
1			99	23.25	23.09	23.14	23.50	
50			0	22.42	22.32	22.20	22.50	
50			25	22.41	22.35	22.38	22.50	
50			50	22.40	22.30	22.37	22.50	
100			0	22.41	22.25	22.25	22.50	
16QAM		1	0	22.36	22.38	22.33	22.50	
		1	50	22.36	22.38	22.28	22.50	
		1	99	22.27	22.31	22.29	22.50	



		50	0	21.28	21.35	21.28	21.50
		50	25	21.27	21.32	21.35	21.50
		50	50	21.36	21.30	21.29	21.50
		100	0	21.39	21.20	21.31	21.50
	64QAM	1	0	22.38	22.28	22.24	22.50
		1	50	22.29	22.34	22.26	22.50
		1	99	22.17	22.28	22.35	22.50
		50	0	21.28	21.30	21.27	21.50
		50	25	21.40	21.17	21.37	21.50
		50	50	21.37	21.36	21.27	21.50
		100	0	21.35	21.26	21.26	21.50

LTE FDD Band 2 Level 3				Conducted Power(dBm)			Tune-up Limit
Bandwidth	Modulation	RB size	RB offset	Channel/Frequency (MHz)			
				18607/1850.7	18900/1880	19193/1909.3	
1.4MHz	QPSK	1	0	22.71	22.74	22.75	23.00
		1	2	22.73	22.68	22.69	23.00
		1	5	22.82	22.65	22.72	23.00
		3	0	22.72	22.83	22.68	23.00
		3	2	22.79	22.71	22.75	23.00
		3	3	22.71	22.79	22.69	23.00
		6	0	21.77	21.83	21.83	22.00
	16QAM	1	0	21.85	21.78	21.85	22.00
		1	2	21.83	21.84	21.77	22.00
		1	5	21.85	21.81	21.79	22.00
		3	0	21.76	21.81	21.75	22.00
		3	2	21.70	21.81	21.75	22.00
		3	3	21.66	21.81	21.70	22.00
		6	0	20.75	20.78	20.71	21.00
	64QAM	1	0	21.78	21.80	21.83	22.00
		1	2	21.86	21.84	21.84	22.00
		1	5	21.74	21.85	21.73	22.00
		3	0	21.76	21.76	21.74	22.00
		3	2	21.71	21.73	21.68	22.00
		3	3	21.67	21.76	21.68	22.00
		6	0	20.71	20.84	20.85	21.00
Bandwidth	Modulation	RB size	RB offset	Channel/Frequency (MHz)			Tune-up Limit
				18615/1851.5	18900/1880	19185/1908.5	
3MHz	QPSK	1	0	22.92	22.78	22.78	23.00
		1	7	22.71	22.71	22.73	23.00
		1	14	22.85	22.70	22.76	23.00
		8	0	21.82	21.76	21.81	22.00



		8	4	21.80	21.78	21.81	22.00
		8	7	21.81	21.83	21.79	22.00
		15	0	21.77	21.87	21.86	22.00
	16QAM	1	0	21.82	21.80	21.81	22.00
		1	7	21.79	21.84	21.78	22.00
		1	14	21.76	21.85	21.82	22.00
		8	0	20.68	20.75	20.68	21.00
		8	4	20.71	20.75	20.74	21.00
		8	7	20.76	20.74	20.83	21.00
	64QAM	15	0	20.78	20.82	20.74	21.00
		1	0	21.81	21.82	21.86	22.00
		1	7	21.80	21.84	21.78	22.00
		1	14	21.76	21.74	21.76	22.00
		8	0	20.87	20.89	20.86	21.00
		8	4	20.82	20.79	20.80	21.00
8		7	20.77	20.83	20.81	21.00	
15	0	20.74	20.77	20.88	21.00		
Bandwidth	Modulation	RB size	RB offset	Channel/Frequency (MHz)			Tune-up Limit
				18625/1852.5	18900/1880	19175/1907.5	
5MHz	QPSK	1	0	22.89	22.76	22.74	23.00
		1	13	22.88	22.67	22.70	23.00
		1	24	22.82	22.65	22.72	23.00
		12	0	21.77	21.90	21.77	22.00
		12	6	21.76	21.72	21.74	22.00
		12	13	21.77	21.67	21.73	22.00
		25	0	21.75	21.86	21.63	22.00
	16QAM	1	0	21.83	21.85	21.81	22.00
		1	13	21.81	21.80	21.76	22.00
		1	24	21.82	21.81	21.55	22.00
		12	0	20.85	20.90	20.84	21.00
		12	6	20.76	20.89	20.83	21.00
		12	13	20.71	20.88	20.77	21.00
		25	0	20.74	20.78	20.88	21.00
	64QAM	1	0	21.76	21.80	21.83	22.00
		1	13	21.86	21.73	21.83	22.00
		1	24	21.77	21.87	21.70	22.00
		12	0	20.85	20.85	20.87	21.00
		12	6	20.77	20.74	20.74	21.00
		12	13	20.72	20.81	20.96	21.00
		25	0	20.70	20.84	20.83	21.00
Bandwidth	Modulation	RB size	RB offset	Channel/Frequency (MHz)			Tune-up Limit
				18650/1855	18900/1880	19150/1905	
10MHz	QPSK	1	0	22.73	22.77	22.77	23.00



		1	25	22.73	22.72	22.74	23.00	
		1	49	22.84	22.69	22.75	23.00	
		25	0	21.83	21.77	21.81	22.00	
		25	13	21.82	21.80	21.81	22.00	
		25	25	21.82	21.74	21.81	22.00	
		50	0	21.82	21.88	21.88	22.00	
	16QAM	1	0	21.82	21.80	21.84	22.00	
		1	25	21.83	21.83	21.82	22.00	
		1	49	21.78	21.81	21.82	22.00	
		25	0	20.88	20.77	20.88	21.00	
		25	13	20.81	20.75	20.83	21.00	
		25	25	20.77	20.75	20.84	21.00	
	64QAM	50	0	20.80	20.83	20.74	21.00	
		1	0	21.81	21.82	21.85	22.00	
		1	25	21.89	21.79	21.86	22.00	
		1	49	21.76	21.89	21.76	22.00	
		25	0	20.88	20.84	20.87	21.00	
		25	13	20.82	20.60	20.80	21.00	
	15MHz	QPSK	25	25	20.78	20.77	20.82	21.00
			50	0	20.76	20.89	20.87	21.00
			1	0	22.90	22.73	22.75	23.00
1			38	22.89	22.71	22.71	23.00	
1			74	22.64	22.64	22.71	23.00	
36			0	21.82	21.74	21.78	22.00	
16QAM		36	18	21.80	21.76	21.78	22.00	
		36	39	21.80	21.89	21.78	22.00	
		75	0	21.81	21.84	21.83	22.00	
		1	0	21.84	21.79	21.87	22.00	
		1	38	21.86	21.85	21.81	22.00	
		1	74	21.86	21.83	21.80	22.00	
64QAM	36	0	20.85	20.76	20.85	21.00		
	36	18	20.96	20.88	20.86	21.00		
	36	39	20.76	20.89	20.82	21.00		
	75	0	20.78	20.78	20.88	21.00		
	1	0	21.77	21.81	21.83	22.00		
	1	38	21.87	21.85	21.84	22.00		
		1	74	21.77	21.88	21.78	22.00	
		36	0	20.87	20.75	20.88	21.00	
		36	18	20.81	20.75	20.80	21.00	
		36	39	20.77	20.86	20.80	21.00	
		75	0	20.74	20.84	20.83	21.00	
Bandwidth	Modulation	RB size	RB offset	Channel/Frequency (MHz)			Tune-up Limit	
				18675/1857.5	18900/1880	19125/1902.5		



Bandwidth	Modulation	RB size	RB offset	Channel/Frequency (MHz)			Tune-up Limit
				18700/1860	18900/1880	19100/1900	
20MHz	QPSK	1	0	22.88	22.69	22.72	23.00
		1	50	22.86	22.67	22.69	23.00
		1	99	22.79	22.63	22.68	23.00
		50	0	21.96	21.86	21.74	22.00
		50	25	21.95	21.89	21.92	22.00
		50	50	21.94	21.84	21.91	22.00
		100	0	21.77	21.79	21.79	22.00
	16QAM	1	0	21.72	21.74	21.81	22.00
		1	50	21.81	21.82	21.76	22.00
		1	99	21.83	21.79	21.77	22.00
		50	0	20.82	20.89	20.82	21.00
		50	25	20.75	20.86	20.82	21.00
		50	50	20.90	20.84	20.77	21.00
		100	0	20.75	20.74	20.85	21.00
	64QAM	1	0	21.74	21.76	21.78	22.00
		1	50	21.83	21.82	21.80	22.00
		1	99	21.71	21.82	21.89	22.00
		50	0	20.82	20.84	20.81	21.00
		50	25	20.76	20.71	20.73	21.00
		50	50	20.73	20.80	20.75	21.00
		100	0	20.89	20.80	20.80	21.00

LTE FDD Band 2 Level 4				Conducted Power(dBm)			Tune-up Limit
Bandwidth	Modulation	RB size	RB offset	Channel/Frequency (MHz)			
				18607/1850.7	18900/1880	19193/1909.3	
1.4MHz	QPSK	1	0	19.25	19.25	19.22	19.50
		1	2	19.23	19.19	19.20	19.50
		1	5	19.19	19.25	19.18	19.50
		3	0	19.16	19.19	19.13	19.50
		3	2	19.21	19.21	19.35	19.50
		3	3	19.33	19.25	19.20	19.50
		6	0	18.22	18.25	18.32	18.50
	16QAM	1	0	18.31	18.28	18.31	18.50
		1	2	18.34	18.31	18.25	18.50
		1	5	18.23	18.31	18.20	18.50
		3	0	18.14	18.15	18.19	18.50
		3	2	18.22	18.23	18.34	18.50
		3	3	18.26	18.29	18.37	18.50
		6	0	17.25	17.29	17.27	17.50
	64QAM	1	0	18.31	18.38	18.31	18.50



Bandwidth	Modulation	RB size	RB offset	Channel/Frequency (MHz)			Tune-up Limit	
				18615/1851.5	18900/1880	19185/1908.5		
		1	2	18.28	18.28	18.37	18.50	
		1	5	18.22	18.22	18.33	18.50	
		3	0	17.94	18.12	18.19	18.50	
		3	2	18.26	18.26	18.30	18.50	
		3	3	18.23	18.27	18.36	18.50	
		6	0	17.27	17.23	17.33	17.50	
3MHz	QPSK	1	0	19.27	19.29	19.25	19.50	
		1	7	19.21	19.22	19.24	19.50	
		1	14	19.22	19.30	19.22	19.50	
		8	0	18.26	18.31	18.26	18.50	
		8	4	18.33	18.31	18.31	18.50	
		8	7	18.27	18.36	18.29	18.50	
	16QAM	15	0	18.22	18.29	18.35	18.50	
		1	0	18.31	18.45	18.33	18.50	
		1	7	18.30	18.31	18.28	18.50	
		1	14	18.28	18.34	18.23	18.50	
		8	0	17.25	17.28	17.31	17.50	
		8	4	17.33	17.36	17.30	17.50	
	64QAM	8	7	17.36	17.25	17.34	17.50	
		15	0	17.28	17.33	17.30	17.50	
		1	0	18.33	18.24	18.33	18.50	
		1	7	18.30	18.28	18.39	18.50	
		1	14	18.24	18.21	18.29	18.50	
		8	0	17.05	17.25	17.31	17.50	
	5MHz	QPSK	8	4	17.37	17.39	17.26	17.50
			8	7	17.33	17.35	17.33	17.50
			15	0	17.30	17.27	17.36	17.50
			1	0	19.24	19.27	19.21	19.50
			1	13	19.19	19.18	19.21	19.50
			1	24	19.19	19.25	19.18	19.50
16QAM		12	0	18.23	18.26	18.22	18.50	
		12	6	18.31	18.27	18.28	18.50	
		12	13	18.29	18.34	18.29	18.50	
		25	0	18.22	18.28	18.33	18.50	
		1	0	18.32	18.29	18.34	18.50	
		1	13	18.30	18.29	18.29	18.50	
			1	24	18.37	18.36	18.19	18.50
			12	0	17.23	17.24	17.28	17.50
			12	6	17.30	17.31	17.30	17.50



		12	13	17.33	17.36	17.34	17.50
		25	0	17.26	17.29	17.25	17.50
	64QAM	1	0	18.34	18.28	18.34	18.50
		1	13	18.31	18.30	18.36	18.50
		1	24	18.25	18.19	18.35	18.50
		12	0	17.03	17.21	17.32	17.50
		12	6	17.34	17.34	17.38	17.50
		12	13	17.30	17.34	17.33	17.50
		25	0	17.28	17.23	17.31	17.50
Bandwidth	Modulation	RB size	RB offset	Channel/Frequency (MHz)			Tune-up Limit
				18650/1855	18900/1880	19150/1905	
10MHz	QPSK	1	0	19.26	19.28	19.24	19.50
		1	25	19.22	19.23	19.25	19.50
		1	49	19.21	19.29	19.21	19.50
		25	0	18.26	18.31	18.26	18.50
		25	13	18.34	18.32	18.35	18.50
		25	25	18.43	18.38	18.35	18.50
		50	0	18.15	18.30	18.26	18.50
	16QAM	1	0	18.36	18.33	18.37	18.50
		1	25	18.35	18.33	18.33	18.50
		1	49	18.29	18.39	18.22	18.50
		25	0	17.26	17.29	17.32	17.50
		25	13	17.32	17.35	17.34	17.50
		25	25	17.36	17.30	17.33	17.50
		50	0	17.29	17.34	17.29	17.50
	64QAM	1	0	18.37	18.39	18.37	18.50
		1	25	18.35	18.30	18.28	18.50
		1	49	18.24	18.21	18.39	18.50
		25	0	17.06	17.26	17.32	17.50
		25	13	17.36	17.38	17.30	17.50
		25	25	17.33	17.28	17.38	17.50
		50	0	17.31	17.28	17.35	17.50
Bandwidth	Modulation	RB size	RB offset	Channel/Frequency (MHz)			Tune-up Limit
				18675/1857.5	18900/1880	19125/1902.5	
15MHz	QPSK	1	0	19.25	19.24	19.22	19.50
		1	38	19.20	19.22	19.22	19.50
		1	74	19.18	19.24	19.17	19.50
		36	0	18.24	18.27	18.23	18.50
		36	18	18.31	18.27	18.31	18.50
		36	39	18.29	18.35	18.31	18.50
		75	0	18.24	18.26	18.32	18.50
	16QAM	1	0	18.37	18.31	18.35	18.50
		1	38	18.39	18.19	18.31	18.50



		1	74	18.37	18.35	18.19	18.50
		36	0	17.23	17.27	17.29	17.50
		36	18	17.29	17.30	17.27	17.50
		36	39	17.23	17.26	17.20	17.50
		75	0	17.26	17.29	17.25	17.50
	64QAM	1	0	18.30	18.26	18.33	18.50
		1	38	18.33	18.27	18.37	18.50
		1	74	18.25	18.20	18.35	18.50
		36	0	17.05	17.28	17.33	17.50
		36	18	17.34	17.35	17.40	17.50
		36	39	17.31	17.35	17.35	17.50
		75	0	17.28	17.23	17.31	17.50
		75	0	17.28	17.23	17.31	17.50
Bandwidth	Modulation	RB size	RB offset	Channel/Frequency (MHz)			Tune-up Limit
				18700/1860	18900/1880	19100/1900	
20MHz	QPSK	1	0	19.22	19.20	19.19	19.50
		1	50	19.19	19.18	19.20	19.50
		1	99	19.16	19.23	19.14	19.50
		50	0	18.21	18.22	18.19	18.50
		50	25	18.29	18.23	18.39	18.50
		50	50	18.37	18.30	18.38	18.50
		100	0	18.21	18.21	18.28	18.50
	16QAM	1	0	18.28	18.38	18.41	18.50
		1	50	18.46	18.28	18.38	18.50
		1	99	18.35	18.28	18.17	18.50
		50	0	17.20	17.23	17.26	17.50
		50	25	17.26	17.28	17.38	17.50
		50	50	17.31	17.32	17.35	17.50
		100	0	17.24	17.25	17.22	17.50
	64QAM	1	0	18.41	18.33	18.41	18.50
		1	50	18.29	18.25	18.33	18.50
		1	99	18.19	18.14	18.45	18.50
		50	0	17.00	17.20	17.26	17.50
		50	25	17.30	17.31	17.34	17.50
		50	50	17.28	17.30	17.31	17.50
		100	0	17.26	17.19	17.28	17.50

LTE FDD Band 2 Level 7				Conducted Power(dBm)			Tune-up Limit
Bandwidth	Modulation	RB size	RB offset	Channel/Frequency (MHz)			
				18607/1850.7	18900/1880	19193/1909.3	
1.4MHz	QPSK	1	0	22.20	22.05	22.13	22.50
		1	2	22.17	22.08	22.02	22.50
		1	5	21.99	22.22	21.97	22.50



		3	0	22.14	22.13	22.00	22.50	
		3	2	22.20	22.08	22.25	22.50	
		3	3	22.23	22.22	22.19	22.50	
		6	0	21.30	21.22	21.24	21.50	
	16QAM	1	0	20.95	21.25	21.27	21.50	
		1	2	20.93	21.19	21.18	21.50	
		1	5	21.11	21.34	21.37	21.50	
		3	0	20.95	21.17	21.20	21.50	
		3	2	20.87	21.10	21.13	21.50	
		3	3	21.05	21.29	21.30	21.50	
		6	0	20.02	20.30	20.32	20.50	
	64QAM	1	0	20.98	21.29	21.24	21.50	
		1	2	20.94	21.17	21.21	21.50	
		1	5	21.02	21.31	21.28	21.50	
		3	0	20.88	21.09	21.13	21.50	
		3	2	20.87	21.08	21.13	21.50	
		3	3	20.97	21.23	21.22	21.50	
		6	0	19.93	20.20	20.23	20.50	
	Bandwidth	Modulation	RB size	RB offset	Channel/Frequency (MHz)			Tune-up Limit
					18615/1851.5	18900/1880	19185/1908.5	
	3MHz	QPSK	1	0	22.22	22.09	22.16	22.50
1			7	22.15	22.11	22.06	22.50	
1			14	22.02	22.27	22.01	22.50	
8			0	21.24	21.25	21.13	21.50	
8			4	21.32	21.18	21.37	21.50	
8			7	21.33	21.33	21.29	21.50	
15			0	21.30	21.26	21.27	21.50	
16QAM		1	0	20.98	21.27	21.30	21.50	
		1	7	20.96	21.19	21.22	21.50	
		1	14	21.13	21.38	21.40	21.50	
		8	0	20.06	20.30	20.32	20.50	
		8	4	19.98	20.23	20.25	20.50	
		8	7	20.15	20.41	20.43	20.50	
		15	0	20.05	20.34	20.35	20.50	
64QAM		1	0	21.01	21.31	21.27	21.50	
		1	7	20.97	21.17	21.23	21.50	
		1	14	21.04	21.30	21.31	21.50	
		8	0	19.99	20.22	20.25	20.50	
		8	4	19.98	20.21	20.25	20.50	
		8	7	20.07	20.35	20.35	20.50	
		15	0	19.96	20.24	20.26	20.50	
Bandwidth	Modulation	RB size	RB offset	Channel/Frequency (MHz)			Tune-up Limit	
				18625/1852.5	18900/1880	19175/1907.5		



5MHz	QPSK	1	0	22.19	22.07	22.12	22.50
		1	13	22.13	22.07	22.03	22.50
		1	24	21.99	22.22	21.97	22.50
		12	0	21.21	21.20	21.09	21.50
		12	6	21.30	21.14	21.32	21.50
		12	13	21.31	21.31	21.25	21.50
		25	0	21.30	21.25	21.25	21.50
	16QAM	1	0	20.95	21.23	21.27	21.50
		1	13	20.93	21.17	21.19	21.50
		1	24	21.10	21.36	21.36	21.50
		12	0	20.04	20.26	20.29	20.50
		12	6	19.95	20.18	20.21	20.50
		12	13	20.12	20.36	20.39	20.50
		25	0	20.03	20.30	20.30	20.50
	64QAM	1	0	20.98	21.31	21.24	21.50
		1	13	20.94	21.19	21.20	21.50
		1	24	21.05	21.28	21.27	21.50
		12	0	19.97	20.18	20.26	20.50
		12	6	19.95	20.16	20.21	20.50
		12	13	20.04	20.30	20.31	20.50
		25	0	19.94	20.20	20.21	20.50
Bandwidth	Modulation	RB size	RB offset	Channel/Frequency (MHz)			Tune-up Limit
				18650/1855	18900/1880	19150/1905	
10MHz	QPSK	1	0	22.21	22.08	22.15	22.50
		1	25	22.16	22.12	22.07	22.50
		1	49	22.01	22.26	22.00	22.50
		25	0	21.24	21.25	21.13	21.50
		25	13	21.33	21.19	21.36	21.50
		25	25	21.33	21.35	21.30	21.50
		50	0	21.34	21.27	21.29	21.50
	16QAM	1	0	20.97	21.26	21.29	21.50
		1	25	20.96	21.21	21.22	21.50
		1	49	21.13	21.38	21.39	21.50
		25	0	20.07	20.31	20.33	20.50
		25	13	19.97	20.22	20.24	20.50
		25	25	20.15	20.41	20.43	20.50
		50	0	20.06	20.35	20.34	20.50
	64QAM	1	0	21.00	21.30	21.26	21.50
		1	25	20.97	21.19	21.23	21.50
		1	49	21.04	21.30	21.30	21.50
		25	0	20.00	20.23	20.26	20.50
		25	13	19.97	20.20	20.24	20.50
		25	25	20.07	20.35	20.35	20.50



Bandwidth	Modulation	RB size	RB offset	Channel/Frequency (MHz)			Tune-up Limit	
				18675/1857.5	18900/1880	19125/1902.5		
				50	0	19.97		20.25
15MHz	QPSK	1	0	22.20	22.04	22.13	22.50	
		1	38	22.14	22.11	22.04	22.50	
		1	74	21.98	22.21	21.96	22.50	
		36	0	21.22	21.21	21.10	21.50	
		36	18	21.30	21.14	21.32	21.50	
		36	39	21.30	21.32	21.26	21.50	
		75	0	21.32	21.23	21.24	21.50	
	16QAM	1	0	20.92	21.24	21.27	21.50	
		1	38	20.94	21.18	21.20	21.50	
		1	74	21.10	21.34	21.36	21.50	
		36	0	20.04	20.29	20.30	20.50	
		36	18	19.94	20.17	20.20	20.50	
		36	39	20.13	20.37	20.40	20.50	
		75	0	20.03	20.30	20.30	20.50	
	64QAM	1	0	20.95	21.28	21.24	21.50	
		1	38	20.95	21.16	21.21	21.50	
		1	74	21.05	21.29	21.31	21.50	
		36	0	19.99	20.25	20.27	20.50	
		36	18	19.95	20.17	20.23	20.50	
		36	39	20.05	20.31	20.32	20.50	
		75	0	19.94	20.20	20.21	20.50	
	Bandwidth	Modulation	RB size	RB offset	Channel/Frequency (MHz)			Tune-up Limit
					18700/1860	18900/1880	19100/1900	
					20MHz	QPSK	1	
20MHz	QPSK	1	50	22.13	22.07	22.02	22.50	
		1	99	21.96	22.20	21.93	22.50	
		50	0	21.19	21.16	21.06	21.50	
		50	25	21.28	21.10	21.29	21.50	
		50	50	21.27	21.27	21.22	21.50	
		100	0	21.29	21.18	21.20	21.50	
		16QAM	1	0	20.96	21.20	21.22	21.50
	1		50	20.90	21.16	21.16	21.50	
	1		99	21.08	21.31	21.34	21.50	
	50		0	20.01	20.25	20.27	20.50	
	50		25	19.91	20.15	20.17	20.50	
	50		50	20.10	20.32	20.36	20.50	
	100		0	20.01	20.26	20.27	20.50	
	64QAM	1	0	20.93	21.24	21.19	21.50	
		1	50	20.91	21.14	21.17	21.50	
		1	99	20.99	21.23	21.25	21.50	



		50	0	19.94	20.17	20.20	20.50
		50	25	19.91	20.13	20.17	20.50
		50	50	20.02	20.26	20.28	20.50
		100	0	19.92	20.16	20.18	20.50

LTE FDD Band 4 Normal Power				Conducted Power(dBm)			Tune-up Limit
Bandwidth	Modulation	RB size	RB offset	Channel/Frequency (MHz)			
				19957/1710.7	20175/1732.5	20393/1754.3	
1.4MHz	QPSK	1	0	23.24	24.42	23.32	25.00
		1	2	24.24	24.16	23.56	25.00
		1	5	23.85	23.72	24.19	25.00
		3	0	23.58	24.43	23.20	25.00
		3	2	24.43	24.13	23.71	25.00
		3	3	24.35	23.25	24.27	25.00
		6	0	23.50	23.46	23.02	24.00
	16QAM	1	0	23.62	23.69	23.53	24.00
		1	2	23.60	23.55	23.22	24.00
		1	5	23.44	23.38	23.28	24.00
		3	0	23.60	23.49	23.35	24.00
		3	2	23.17	23.07	22.88	24.00
		3	3	22.60	22.54	22.42	24.00
		6	0	22.12	22.06	21.72	23.00
	64QAM	1	0	23.62	23.56	23.10	24.00
		1	2	23.20	23.15	23.07	24.00
		1	5	23.24	23.22	23.02	24.00
		3	0	23.42	23.34	23.21	24.00
		3	2	23.44	23.36	23.33	24.00
		3	3	22.64	22.57	22.39	24.00
		6	0	22.15	22.09	21.90	23.00
Bandwidth	Modulation	RB size	RB offset	Channel/Frequency (MHz)			Tune-up Limit
				19965/1711.5	20175/1732.5	20385/1753.5	
3MHz	QPSK	1	0	23.26	24.46	23.35	25.00
		1	7	24.22	24.19	23.60	25.00
		1	14	23.88	23.77	24.23	25.00
		8	0	22.68	23.55	22.33	24.00
		8	4	23.55	23.23	22.83	24.00
		8	7	23.45	22.36	23.37	24.00
		15	0	23.50	23.50	23.05	24.00
	16QAM	1	0	23.65	23.71	23.56	24.00
		1	7	23.63	23.55	23.26	24.00
		1	14	23.46	23.42	23.31	24.00
		8	0	22.71	22.62	22.47	23.00



Bandwidth	Modulation	RB size	RB offset	Channel/Frequency (MHz)			Tune-up Limit
				19975/1712.5	20175/1732.5	20375/1752.5	
	64QAM	8	4	22.28	22.20	22.00	23.00
		8	7	21.70	21.66	21.55	23.00
		15	0	22.15	22.10	21.75	23.00
		1	0	23.65	23.58	23.13	24.00
		1	7	23.23	23.15	23.09	24.00
		1	14	23.26	23.21	23.05	24.00
		8	0	22.53	22.47	22.33	23.00
		8	4	22.55	22.49	22.45	23.00
		8	7	21.74	21.69	21.52	23.00
		15	0	22.18	22.13	21.93	23.00
Bandwidth	Modulation	RB size	RB offset	Channel/Frequency (MHz)			Tune-up Limit
				19975/1712.5	20175/1732.5	20375/1752.5	
5MHz	QPSK	1	0	23.23	24.44	23.31	25.00
		1	13	24.20	24.15	23.57	25.00
		1	24	23.85	23.72	24.19	25.00
		12	0	22.65	23.50	22.29	24.00
		12	6	23.53	23.19	22.78	24.00
		12	13	23.43	22.34	23.33	24.00
		25	0	23.50	23.49	23.03	24.00
	16QAM	1	0	23.62	23.67	23.53	24.00
		1	13	23.60	23.53	23.23	24.00
		1	24	23.43	23.40	23.27	24.00
		12	0	22.69	22.58	22.44	23.00
		12	6	22.25	22.15	21.96	23.00
		12	13	21.67	21.61	21.51	23.00
		25	0	22.13	22.06	21.70	23.00
	64QAM	1	0	23.62	23.58	23.10	24.00
		1	13	23.20	23.17	23.06	24.00
		1	24	23.27	23.19	23.01	24.00
		12	0	22.51	22.43	22.34	23.00
		12	6	22.52	22.44	22.41	23.00
		12	13	21.71	21.64	21.48	23.00
		25	0	22.16	22.09	21.88	23.00
Bandwidth	Modulation	RB size	RB offset	Channel/Frequency (MHz)			Tune-up Limit
				20000/1715	20175/1732.5	20350/1750	
10MHz	QPSK	1	0	23.25	24.45	23.34	25.00
		1	25	24.23	24.20	23.61	25.00
		1	49	23.87	23.76	24.22	25.00
		25	0	22.68	23.55	22.33	24.00
		25	13	23.56	23.24	22.82	24.00
		25	25	23.45	22.38	23.38	24.00
		50	0	23.54	23.51	23.07	24.00
	16QAM	1	0	23.64	23.70	23.55	24.00



		1	25	23.63	23.57	23.26	24.00
		1	49	23.46	23.42	23.30	24.00
		25	0	22.72	22.63	22.48	23.00
		25	13	22.27	22.19	21.99	23.00
		25	25	21.70	21.66	21.55	23.00
		50	0	22.16	22.11	21.74	23.00
	64QAM	1	0	23.64	23.57	23.12	24.00
		1	25	23.23	23.17	23.09	24.00
		1	49	23.26	23.21	23.04	24.00
		25	0	22.54	22.48	22.34	23.00
		25	13	22.54	22.48	22.44	23.00
		25	25	21.74	21.69	21.52	23.00
	50	0	22.19	22.14	21.92	23.00	
Bandwidth	Modulation	RB size	RB offset	Channel/Frequency (MHz)			Tune-up Limit
				20025/1717.5	20175/1732.5	20325/1747.5	
15MHz	QPSK	1	0	23.24	24.41	23.32	25.00
		1	38	24.21	24.19	23.58	25.00
		1	74	23.84	23.71	24.18	25.00
		36	0	22.66	23.51	22.30	24.00
		36	18	23.53	23.19	22.78	24.00
		36	39	23.42	22.35	23.34	24.00
		75	0	23.52	23.47	23.02	24.00
	16QAM	1	0	23.59	23.68	23.53	24.00
		1	38	23.61	23.54	23.24	24.00
		1	74	23.43	23.38	23.27	24.00
		36	0	22.69	22.61	22.45	23.00
		36	18	22.24	22.14	21.95	23.00
		36	39	21.68	21.62	21.52	23.00
		75	0	22.13	22.06	21.70	23.00
	64QAM	1	0	23.59	23.55	23.10	24.00
		1	38	23.21	23.14	23.07	24.00
		1	74	23.27	23.20	23.05	24.00
		36	0	22.53	22.50	22.35	23.00
		36	18	22.52	22.45	22.43	23.00
		36	39	21.72	21.65	21.49	23.00
		75	0	22.16	22.09	21.88	23.00
Bandwidth	Modulation	RB size	RB offset	Channel/Frequency (MHz)			Tune-up Limit
				20050/1720	20175/1732.5	20300/1745	
20MHz	QPSK	1	0	23.21	24.37	23.29	25.00
		1	50	24.20	24.15	23.56	25.00
		1	99	23.82	23.70	24.15	25.00
		50	0	22.63	23.46	22.26	24.00
		50	25	23.51	23.15	22.75	24.00



		50	50	23.39	22.30	23.30	24.00
		100	0	23.49	23.42	22.98	24.00
	16QAM	1	0	23.72	23.64	23.48	24.00
		1	50	23.57	23.52	23.20	24.00
		1	99	23.41	23.35	23.25	24.00
		50	0	22.66	22.57	22.42	23.00
		50	25	22.21	22.12	21.92	23.00
		50	50	21.65	21.57	21.48	23.00
		100	0	22.11	22.02	21.67	23.00
	64QAM	1	0	23.57	23.51	23.05	24.00
		1	50	23.17	23.12	23.03	24.00
		1	99	23.21	23.14	22.99	24.00
		50	0	22.48	22.42	22.28	23.00
		50	25	22.48	22.41	22.37	23.00
50		50	21.69	21.60	21.45	23.00	
100		0	22.14	22.05	21.85	23.00	

LTE FDD Band 4 Level 5				Conducted Power(dBm)			Tune-up Limit
Bandwidth	Modulation	RB size	RB offset	Channel/Frequency (MHz)			
				19957/1710.7	20175/1732.5	20393/1754.3	
1.4MHz	QPSK	1	0	22.32	22.36	22.45	22.50
		1	2	22.29	22.20	22.22	22.50
		1	5	22.22	22.18	22.27	22.50
		3	0	22.33	22.32	22.40	22.50
		3	2	22.28	22.36	22.31	22.50
		3	3	22.27	22.21	22.33	22.50
		6	0	21.33	21.34	21.35	21.50
	16QAM	1	0	21.31	21.37	21.37	21.50
		1	2	21.42	21.39	21.35	21.50
		1	5	21.38	21.28	21.39	21.50
		3	0	21.32	21.25	21.27	21.50
		3	2	21.29	21.30	21.31	21.50
		3	3	21.29	21.32	21.30	21.50
		6	0	20.33	20.35	20.44	20.50
	64QAM	1	0	21.32	21.30	21.37	21.50
		1	2	21.31	21.34	21.27	21.50
		1	5	21.38	21.26	21.40	21.50
		3	0	21.27	21.24	21.32	21.50
		3	2	21.27	21.24	21.34	21.50
		3	3	21.23	21.33	21.25	21.50
		6	0	20.35	20.39	20.28	20.50
Bandwidth	Modulation	RB size	RB offset	Channel/Frequency (MHz)			Tune-up



				19965/1711.5	20175/1732.5	20385/1753.5	Limit
3MHz	QPSK	1	0	22.34	22.40	22.48	22.50
		1	7	22.27	22.23	22.26	22.50
		1	14	22.25	22.23	22.31	22.50
		8	0	21.29	21.29	21.39	21.50
		8	4	21.40	21.32	21.29	21.50
		8	7	21.37	21.32	21.29	21.50
		15	0	21.32	21.38	21.38	21.50
	16QAM	1	0	21.33	21.39	21.40	21.50
		1	7	21.45	21.39	21.39	21.50
		1	14	21.40	21.31	21.28	21.50
		8	0	20.29	20.38	20.39	20.50
		8	4	20.40	20.29	20.29	20.50
		8	7	20.39	20.30	20.29	20.50
		15	0	20.36	20.39	20.33	20.50
	64QAM	1	0	21.34	21.45	21.26	21.50
		1	7	21.34	21.34	21.28	21.50
		1	14	21.40	21.25	21.29	21.50
		8	0	20.38	20.37	20.30	20.50
		8	4	20.38	20.37	20.32	20.50
		8	7	20.33	20.31	20.38	20.50
		15	0	20.38	20.29	20.30	20.50
Bandwidth	Modulation	RB size	RB offset	Channel/Frequency (MHz)			Tune-up Limit
				19975/1712.5	20175/1732.5	20375/1752.5	
5MHz	QPSK	1	0	22.31	22.38	22.30	22.50
		1	13	22.25	22.19	22.23	22.50
		1	24	22.22	22.18	22.27	22.50
		12	0	21.40	21.38	21.35	21.50
		12	6	21.38	21.28	21.38	21.50
		12	13	21.35	21.30	21.39	21.50
		25	0	21.46	21.37	21.36	21.50
	16QAM	1	0	21.44	21.21	21.37	21.50
		1	13	21.42	21.23	21.36	21.50
		1	24	21.37	21.43	21.24	21.50
		12	0	20.41	20.20	20.36	20.50
		12	6	20.37	20.38	20.39	20.50
		12	13	20.36	20.39	20.39	20.50
		25	0	20.34	20.35	20.28	20.50
	64QAM	1	0	21.31	21.31	21.37	21.50
		1	13	21.31	21.36	21.39	21.50
		1	24	21.27	21.23	21.39	21.50
		12	0	20.36	20.33	20.31	20.50
		12	6	20.35	20.32	20.28	20.50



Bandwidth	Modulation	RB size	RB offset	Channel/Frequency (MHz)			Tune-up Limit	
				20000/1715	20175/1732.5	20350/1750		
		12	13	20.30	20.40	20.34	20.50	
		25	0	20.36	20.39	20.39	20.50	
10MHz	QPSK	1	0	22.33	22.39	22.47	22.50	
		1	25	22.28	22.24	22.27	22.50	
		1	49	22.24	22.22	22.30	22.50	
		25	0	21.26	21.40	21.36	21.50	
		25	13	21.24	21.30	21.25	21.50	
		25	25	21.37	21.34	21.27	21.50	
		50	0	21.33	21.39	21.40	21.50	
	16QAM	1	0	21.29	21.38	21.39	21.50	
		1	25	21.28	21.24	21.39	21.50	
		1	49	21.40	21.28	21.24	21.50	
		25	0	20.27	20.39	20.40	20.50	
		25	13	20.39	20.25	20.25	20.50	
		25	25	20.39	20.27	20.26	20.50	
		50	0	20.37	20.40	20.29	20.50	
	64QAM	1	0	21.30	21.27	21.39	21.50	
		1	25	21.34	21.36	21.27	21.50	
		1	49	21.40	21.25	21.25	21.50	
		25	0	20.39	20.38	20.28	20.50	
		25	13	20.37	20.36	20.28	20.50	
		25	25	20.33	20.28	20.38	20.50	
		50	0	20.39	20.27	20.26	20.50	
	Bandwidth	Modulation	RB size	RB offset	Channel/Frequency (MHz)			Tune-up Limit
					20025/1717.5	20175/1732.5	20325/1747.5	
	15MHz	QPSK	1	0	22.32	22.35	22.28	22.50
1			38	22.26	22.23	22.24	22.50	
1			74	22.21	22.17	22.26	22.50	
36			0	21.24	21.36	21.33	21.50	
36			18	21.38	21.25	21.38	21.50	
36			39	21.34	21.31	21.23	21.50	
75			0	21.31	21.35	21.35	21.50	
16QAM		1	0	21.24	21.36	21.37	21.50	
		1	38	21.26	21.38	21.37	21.50	
		1	74	21.37	21.24	21.38	21.50	
		36	0	20.24	20.37	20.37	20.50	
		36	18	20.36	20.37	20.38	20.50	
		36	39	20.37	20.23	20.23	20.50	
		75	0	20.34	20.35	20.25	20.50	
64QAM		1	0	21.25	21.25	21.37	21.50	
		1	38	21.32	21.33	21.23	21.50	



Bandwidth	Modulation	RB size	RB offset	Channel/Frequency (MHz)			Tune-up Limit
				20050/1720	20175/1732.5	20300/1745	
20MHz	QPSK	1	74	21.24	21.24	21.26	21.50
		36	0	20.38	20.40	20.29	20.50
		36	18	20.35	20.33	20.27	20.50
		36	39	20.31	20.24	20.35	20.50
		75	0	20.36	20.39	20.39	20.50
		1	0	22.29	22.31	22.42	22.50
		1	50	22.25	22.19	22.22	22.50
	1	99	22.19	22.16	22.23	22.50	
	50	0	21.38	21.48	21.46	21.50	
	50	25	21.36	21.38	21.35	21.50	
	50	50	21.31	21.26	21.36	21.50	
	100	0	21.45	21.30	21.31	21.50	
	16QAM	1	0	21.33	21.32	21.32	21.50
		1	50	21.39	21.36	21.33	21.50
		1	99	21.35	21.38	21.36	21.50
		50	0	20.38	20.33	20.34	20.50
		50	25	20.33	20.35	20.35	20.50
		50	50	20.34	20.35	20.36	20.50
		100	0	20.32	20.31	20.39	20.50
	64QAM	1	0	21.40	21.38	21.32	21.50
		1	50	21.28	21.31	21.36	21.50
		1	99	21.35	21.18	21.37	21.50
		50	0	20.33	20.32	20.39	20.50
		50	25	20.31	20.29	20.38	20.50
		50	50	20.28	20.36	20.31	20.50
		100	0	20.34	20.35	20.36	20.50

LTE FDD Band 5 Normal Power				Conducted Power(dBm)			Tune-up Limit
Bandwidth	Modulation	RB size	RB offset	Channel/Frequency (MHz)			
				20407/824.7	20525/836.5	20643/848.3	
1.4MHz	QPSK	1	0	24.56	24.56	24.60	25.00
		1	2	24.49	24.56	24.58	25.00
		1	5	24.57	24.48	24.26	25.00
		3	0	24.55	24.64	24.57	25.00
		3	2	24.55	24.64	24.74	25.00
		3	3	24.63	24.59	24.71	25.00
		6	0	23.79	23.71	23.72	24.00
	16QAM	1	0	23.62	23.68	23.57	24.00
		1	2	23.60	23.64	23.43	24.00
		1	5	23.70	23.70	23.62	24.00



		3	0	23.38	23.57	23.47	24.00
		3	2	23.44	23.65	23.52	24.00
		3	3	23.44	23.66	23.55	24.00
		6	0	22.40	22.68	22.46	23.00
	64QAM	1	0	23.61	23.67	23.73	24.00
		1	2	23.77	23.77	23.70	24.00
		1	5	23.57	23.63	23.67	24.00
		3	0	23.39	23.58	23.48	24.00
		3	2	23.54	23.72	23.68	24.00
		3	3	23.33	23.56	23.42	24.00
6	0	22.44	22.69	22.56	23.00		
Bandwidth	Modulation	RB size	RB offset	Channel/Frequency (MHz)			Tune-up Limit
				20415/825.5	20525/836.5	20635/847.5	
3MHz	QPSK	1	0	24.58	24.60	24.63	25.00
		1	7	24.47	24.59	24.62	25.00
		1	14	24.60	24.53	24.30	25.00
		8	0	23.65	23.76	23.70	24.00
		8	4	23.67	23.74	23.63	24.00
		8	7	23.73	23.70	23.81	24.00
		15	0	23.79	23.75	23.75	24.00
	16QAM	1	0	23.65	23.67	23.71	24.00
		1	7	23.63	23.61	23.67	24.00
		1	14	23.72	23.71	23.62	24.00
		8	0	22.49	22.70	22.59	23.00
		8	4	22.55	22.78	22.64	23.00
		8	7	22.54	22.78	22.68	23.00
		15	0	22.43	22.72	22.49	23.00
	64QAM	1	0	23.61	23.66	23.73	24.00
		1	7	23.80	23.74	23.69	24.00
		1	14	23.59	23.82	23.70	24.00
		8	0	22.50	22.71	22.60	23.00
		8	4	22.65	22.62	22.80	23.00
		8	7	22.43	22.68	22.55	23.00
		15	0	22.47	22.73	22.59	23.00
Bandwidth	Modulation	RB size	RB offset	Channel/Frequency (MHz)			Tune-up Limit
				20425/826.5	20525/836.5	20625/846.5	
5MHz	QPSK	1	0	24.56	24.55	24.60	25.00
		1	13	24.46	24.59	24.60	25.00
		1	24	24.56	24.47	24.25	25.00
		12	0	23.63	23.72	23.67	24.00
		12	6	23.65	23.70	23.56	24.00
		12	13	23.70	23.69	23.78	24.00
		25	0	23.81	23.47	23.72	24.00



	16QAM	1	0	23.59	23.66	23.77	24.00
		1	13	23.61	23.68	23.65	24.00
		1	24	23.69	23.72	23.56	24.00
		12	0	22.47	22.69	22.57	23.00
		12	6	22.51	22.47	22.59	23.00
		12	13	22.52	22.74	22.65	23.00
		25	0	22.41	22.68	22.44	23.00
	64QAM	1	0	23.65	23.69	23.71	24.00
		1	13	23.62	23.64	23.69	24.00
		1	24	23.60	23.46	23.70	24.00
		12	0	22.50	22.74	22.62	23.00
		12	6	22.62	22.56	22.53	23.00
		12	13	22.41	22.64	22.52	23.00
		25	0	22.45	22.69	22.54	23.00
Bandwidth	Modulation	RB size	RB offset	Channel/Frequency (MHz)			Tune-up Limit
				20450/829	20525/836.5	20600/844	
10MHz	QPSK	1	0	24.53	24.51	24.57	25.00
		1	25	24.45	24.55	24.58	25.00
		1	49	24.54	24.46	24.56	25.00
		25	0	23.60	23.67	23.63	24.00
		25	13	23.63	23.66	23.78	24.00
		25	25	23.67	23.64	23.74	24.00
		50	0	23.78	23.67	23.68	24.00
	16QAM	1	0	23.62	23.70	23.72	24.00
		1	25	23.57	23.71	23.61	24.00
		1	49	23.67	23.64	23.69	24.00
		25	0	22.44	22.65	22.54	23.00
		25	13	22.48	22.70	22.56	23.00
		25	25	22.49	22.69	22.61	23.00
		50	0	22.39	22.64	22.41	23.00
	64QAM	1	0	23.76	23.61	23.67	24.00
		1	25	23.74	23.73	23.65	24.00
		1	49	23.54	23.75	23.64	24.00
		25	0	22.45	22.66	22.55	23.00
		25	13	22.58	22.77	22.72	23.00
		25	25	22.38	22.59	22.48	23.00
		50	0	22.43	22.65	22.51	23.00

LTE FDD Band 5 Level 1				Conducted Power(dBm)			Tune-up Limit
Bandwidth	Modulation	RB size	RB offset	Channel/Frequency (MHz)			
				20407/824.7	20525/836.5	20643/848.3	
1.4MHz	QPSK	1	0	24.05	24.03	24.12	24.50



		1	2	23.99	24.04	24.08	24.50	
		1	5	24.06	24.09	24.09	24.50	
		3	0	24.05	24.15	24.09	24.50	
		3	2	24.04	24.20	24.10	24.50	
		3	3	24.00	24.13	24.14	24.50	
		6	0	23.12	23.13	23.13	23.50	
	16QAM	1	0	23.32	23.38	23.26	23.50	
		1	2	23.30	23.23	23.34	23.50	
		1	5	23.40	23.25	23.20	23.50	
		3	0	23.08	23.02	23.18	23.50	
		3	2	23.14	23.21	23.23	23.50	
		3	3	23.14	23.12	23.26	23.50	
	64QAM	6	0	22.10	22.14	22.17	22.50	
		1	0	23.23	23.28	23.25	23.50	
		1	2	23.47	23.47	23.42	23.50	
		1	5	23.27	23.16	23.16	23.50	
		3	0	23.09	22.93	23.19	23.50	
		3	2	23.24	23.18	23.17	23.50	
	3MHz	QPSK	3	3	23.03	23.11	23.13	23.50
			6	0	22.14	22.10	22.27	22.50
			1	0	24.05	24.02	24.12	24.50
1			7	23.96	24.07	24.10	24.50	
1			14	24.05	24.08	24.08	24.50	
8			0	23.13	23.23	23.19	23.50	
8			4	23.14	23.26	23.17	23.50	
16QAM	8	7	23.07	23.23	23.21	23.50		
	15	0	23.14	23.14	23.13	23.50		
	1	0	23.29	23.14	23.25	23.50		
	1	7	23.31	23.19	23.36	23.50		
	1	14	23.16	23.21	23.24	23.50		
	8	0	22.17	22.14	22.28	22.50		
	8	4	22.21	22.28	22.30	22.50		
64QAM	8	7	22.22	22.20	22.13	22.50		
	15	0	22.11	22.14	22.15	22.50		
	1	0	23.25	23.27	23.23	23.50		
	1	7	23.25	23.23	23.25	23.50		
	1	14	23.30	23.36	23.18	23.50		
	8	0	22.20	22.09	22.10	22.50		
	8	4	22.32	22.27	22.26	22.50		
		8	7	22.11	22.19	22.23	22.50	
		15	0	22.15	22.10	22.25	22.50	
Bandwidth	Modulation	RB size	RB offset	Channel/Frequency (MHz)			Tune-up Limit	
				20415/825.5	20525/836.5	20635/847.5		



Bandwidth	Modulation	RB size	RB offset	Channel/Frequency (MHz)			Tune-up Limit
				20425/826.5	20525/836.5	20625/846.5	
5MHz	QPSK	1	0	24.06	24.06	24.14	24.50
		1	13	23.98	24.08	24.13	24.50
		1	24	24.08	24.13	24.12	24.50
		12	0	23.15	23.27	23.22	23.50
		12	6	23.17	23.31	23.21	23.50
		12	13	23.10	23.26	23.25	23.50
		25	0	23.16	23.18	23.18	23.50
	16QAM	1	0	23.34	23.14	23.25	23.50
		1	13	23.33	23.19	23.38	23.50
		1	24	23.17	23.21	23.20	23.50
		12	0	22.20	22.16	22.31	22.50
		12	6	22.24	22.33	22.34	22.50
		12	13	22.24	22.24	22.14	22.50
		25	0	22.14	22.19	22.19	22.50
	64QAM	1	0	23.23	23.29	23.21	23.50
		1	13	23.22	23.24	23.22	23.50
		1	24	23.29	23.12	23.15	23.50
		12	0	22.21	22.07	22.32	22.50
		12	6	22.34	22.30	22.25	22.50
		12	13	22.13	22.23	22.26	22.50
		25	0	22.18	22.15	22.29	22.50
Bandwidth	Modulation	RB size	RB offset	Channel/Frequency (MHz)			Tune-up Limit
				20450/829	20525/836.5	20600/844	
10MHz	QPSK	1	0	24.02	23.98	24.09	24.50
		1	25	23.95	24.03	24.08	24.50
		1	49	24.03	24.07	24.05	24.50
		25	0	23.10	23.18	23.15	23.50
		25	13	23.12	23.22	23.14	23.50
		25	25	23.04	23.18	23.17	23.50
		50	0	23.11	23.09	23.09	23.50
	16QAM	1	0	23.32	23.33	23.43	23.50
		1	25	23.27	23.49	23.32	23.50
		1	49	23.37	23.48	23.50	23.50
		25	0	22.14	22.10	22.25	22.50
		25	13	22.18	22.26	22.27	22.50
		25	25	22.19	22.15	22.32	22.50
		50	0	22.09	22.10	22.12	22.50
	64QAM	1	0	23.46	23.23	23.45	23.50
		1	25	23.44	23.44	23.47	23.50
		1	49	23.24	23.30	23.35	23.50
		25	0	22.15	22.01	22.26	22.50



		25	13	22.28	22.23	22.43	22.50
		25	25	22.08	22.14	22.19	22.50
		50	0	22.13	22.06	22.22	22.50

LTE FDD Band 12 Normal Power				Conducted Power(dBm)			Tune-up Limit
Bandwidth	Modulation	RB size	RB offset	Channel/Frequency (MHz)			
				23017/699.7	23095/707.5	23173/715.3	
1.4MHz	QPSK	1	0	24.51	24.60	24.59	25.00
		1	2	24.55	24.50	24.49	25.00
		1	5	24.39	24.44	23.89	25.00
		3	0	24.51	24.59	24.50	25.00
		3	2	24.46	24.58	24.56	25.00
		3	3	24.51	24.51	24.48	25.00
		6	0	23.71	23.67	23.61	24.00
	16QAM	1	0	23.62	23.70	23.75	24.00
		1	2	23.60	23.55	23.56	24.00
		1	5	23.77	23.66	23.72	24.00
		3	0	23.49	23.37	23.43	24.00
		3	2	23.47	23.37	23.42	24.00
		3	3	23.44	23.34	23.37	24.00
		6	0	22.42	22.39	22.41	23.00
	64QAM	1	0	23.70	23.67	23.74	24.00
		1	2	23.68	23.64	23.71	24.00
		1	5	23.70	23.65	23.65	24.00
		3	0	23.62	23.49	23.55	24.00
		3	2	23.74	23.60	23.68	24.00
		3	3	23.65	23.57	23.59	24.00
		6	0	22.71	22.65	22.70	23.00
Bandwidth	Modulation	RB size	RB offset	Channel/Frequency (MHz)			Tune-up Limit
				23025/700.5	23095/707.5	23165/714.5	
3MHz	QPSK	1	0	24.53	24.64	24.62	25.00
		1	7	24.53	24.53	24.53	25.00
		1	14	24.42	24.49	23.93	25.00
		8	0	23.61	23.71	23.63	24.00
		8	4	23.58	23.68	23.68	24.00
		8	7	23.61	23.62	23.58	24.00
		15	0	23.71	23.71	23.64	24.00
	16QAM	1	0	23.65	23.72	23.78	24.00
		1	7	23.63	23.55	23.60	24.00
		1	14	23.79	23.70	23.75	24.00
		8	0	22.60	22.50	22.55	23.00
		8	4	22.58	22.50	22.54	23.00



Bandwidth	Modulation	RB size	RB offset	Channel/Frequency (MHz)			Tune-up Limit
				23035/701.5	23095/707.5	23155/713.5	
	64QAM	8	7	22.54	22.46	22.50	23.00
		15	0	22.45	22.43	22.44	23.00
		1	0	23.97	23.94	23.92	24.00
		1	7	23.69	23.64	23.73	24.00
		1	14	23.72	23.64	23.68	24.00
		8	0	22.73	22.62	22.67	23.00
		8	4	22.85	22.73	22.80	23.00
		8	7	22.75	22.69	22.72	23.00
		15	0	22.74	22.69	22.73	23.00
5MHz	QPSK	1	0	24.50	24.62	24.58	25.00
		1	13	24.51	24.49	24.50	25.00
		1	24	24.39	24.44	23.89	25.00
		12	0	23.58	23.66	23.59	24.00
		12	6	23.56	23.64	23.63	24.00
		12	13	23.59	23.60	23.54	24.00
		25	0	23.71	23.70	23.62	24.00
	16QAM	1	0	23.62	23.68	23.75	24.00
		1	13	23.60	23.53	23.57	24.00
		1	24	23.76	23.68	23.71	24.00
		12	0	22.58	22.46	22.52	23.00
		12	6	22.55	22.45	22.50	23.00
		12	13	22.51	22.41	22.46	23.00
		25	0	22.43	22.39	22.39	23.00
	64QAM	1	0	23.71	23.69	23.74	24.00
		1	13	23.68	23.66	23.70	24.00
		1	24	23.73	23.62	23.64	24.00
		12	0	22.71	22.58	22.68	23.00
		12	6	22.82	22.68	22.76	23.00
		12	13	22.72	22.64	22.68	23.00
		25	0	22.72	22.65	22.68	23.00
Bandwidth	Modulation	RB size	RB offset	Channel/Frequency (MHz)			Tune-up Limit
				23060/704	23095/707.5	23130/711	
10MHz	QPSK	1	0	24.48	24.55	24.56	25.00
		1	25	24.51	24.49	24.49	25.00
		1	49	24.36	24.42	23.85	25.00
		25	0	23.56	23.62	23.56	24.00
		25	13	23.54	23.60	23.60	24.00
		25	25	23.55	23.56	23.51	24.00
		50	0	23.70	23.63	23.57	24.00
	16QAM	1	0	23.74	23.65	23.70	24.00
		1	25	23.57	23.52	23.54	24.00



		1	49	23.74	23.63	23.69	24.00
		25	0	22.55	22.45	22.50	23.00
		25	13	22.51	22.42	22.46	23.00
		25	25	22.49	22.37	22.43	23.00
		50	0	22.41	22.35	22.36	23.00
	64QAM	1	0	23.74	23.62	23.69	24.00
		1	25	23.73	23.61	23.67	24.00
		1	49	23.67	23.57	23.62	24.00
		25	0	22.68	22.57	22.62	23.00
		25	13	22.78	22.65	22.72	23.00
		25	25	22.70	22.60	22.65	23.00
		50	0	22.70	22.61	22.65	23.00

LTE FDD Band 13 Normal Power				Conducted Power(dBm)			Tune-up Limit
Bandwidth	Modulation	RB size	RB offset	Channel/Frequency (MHz)			
				23205/779.5	23230/782	23255/784.5	
5MHz	QPSK	1	0	24.65	24.61	24.70	25.00
		1	13	24.64	24.61	24.66	25.00
		1	24	24.65	24.60	24.71	25.00
		12	0	23.82	23.77	23.81	24.00
		12	6	23.83	23.78	23.76	24.00
		12	13	23.78	23.84	23.86	24.00
		25	0	23.75	23.70	23.76	24.00
	16QAM	1	0	23.71	23.66	23.78	24.00
		1	13	23.79	23.82	23.74	24.00
		1	24	23.75	23.80	23.72	24.00
		12	0	22.64	22.58	22.69	23.00
		12	6	22.74	22.68	22.81	23.00
		12	13	22.76	22.71	22.81	23.00
		25	0	22.69	22.64	22.73	23.00
	64QAM	1	0	23.80	23.73	23.88	24.00
		1	13	23.77	23.80	23.72	24.00
		1	24	23.83	23.81	23.71	24.00
		12	0	22.78	22.72	22.83	23.00
		12	6	22.82	22.76	22.79	23.00
		12	13	22.65	22.60	22.70	23.00
		25	0	22.72	22.67	22.76	23.00
Bandwidth	Modulation	RB size	RB offset	Channel/Frequency (MHz)			Tune-up Limit
				/	23230/782	/	
10MHz	QPSK	1	0	/	24.59	/	25.00
		1	25	/	24.61	/	25.00



		1	49	/	24.57	/	25.00
		25	0	/	23.75	/	24.00
		25	13	/	23.76	/	24.00
		25	25	/	23.80	/	24.00
		50	0	/	23.69	/	24.00
	16QAM	1	0	/	23.86	/	24.00
		1	25	/	23.79	/	24.00
		1	49	/	23.78	/	24.00
		25	0	/	22.55	/	23.00
		25	13	/	22.64	/	23.00
		25	25	/	22.69	/	23.00
		50	0	/	22.62	/	23.00
	64QAM	1	0	/	23.76	/	24.00
		1	25	/	23.74	/	24.00
		1	49	/	23.78	/	24.00
		25	0	/	22.69	/	23.00
		25	13	/	22.81	/	23.00
		25	25	/	22.76	/	23.00
		50	0	/	22.65	/	23.00

LTE FDD Band 66 Normal Power				Conducted Power(dBm)			Tune-up Limit
Bandwidth	Modulation	RB size	RB offset	Channel/Frequency (MHz)			
				131979/1710.7	132322/1745	132665/1779.3	
1.4MHz	QPSK	1	0	24.20	24.24	24.01	25.00
		1	2	24.10	23.84	23.93	25.00
		1	5	24.17	23.87	23.89	25.00
		3	0	24.42	24.20	24.15	25.00
		3	2	24.26	24.22	24.18	25.00
		3	3	24.52	24.21	24.21	25.00
		6	0	23.46	23.33	23.22	24.00
	16QAM	1	0	23.56	23.81	23.38	24.00
		1	2	23.54	23.65	23.27	24.00
		1	5	23.56	23.64	23.29	24.00
		3	0	23.40	23.13	23.15	24.00
		3	2	23.39	23.20	23.20	24.00
		3	3	23.37	23.21	23.20	24.00
		6	0	22.47	22.33	22.26	23.00
	64QAM	1	0	23.49	23.39	23.12	24.00
		1	2	23.35	23.24	23.02	24.00
		1	5	23.50	23.21	22.93	24.00
		3	0	23.27	23.19	23.21	24.00
		3	2	23.30	23.22	23.24	24.00



Bandwidth	Modulation	RB size	RB offset	Channel/Frequency (MHz)			Tune-up Limit
				1319871711.5	132322/1745	132657/1778.5	
3MHz	QPSK	3	3	23.29	23.22	23.12	24.00
		6	0	22.35	22.28	22.22	23.00
		1	0	24.22	24.28	24.04	25.00
		1	7	24.08	23.87	23.97	25.00
		1	14	24.20	23.92	23.93	25.00
		8	0	23.52	23.32	23.28	24.00
		8	4	23.38	23.32	23.30	24.00
	8	7	23.62	23.32	23.31	24.00	
	15	0	23.46	23.37	23.25	24.00	
	16QAM	1	0	23.59	23.83	23.41	24.00
		1	7	23.57	23.65	23.31	24.00
		1	14	23.58	23.68	23.32	24.00
		8	0	22.51	22.26	22.27	23.00
		8	4	22.50	22.33	22.32	23.00
		8	7	22.47	22.33	22.33	23.00
		15	0	22.50	22.37	22.29	23.00
	64QAM	1	0	23.52	23.41	23.15	24.00
		1	7	23.38	23.24	23.04	24.00
		1	14	23.52	23.20	22.96	24.00
		8	0	22.38	22.32	22.33	23.00
		8	4	22.41	22.35	22.36	23.00
		8	7	22.39	22.34	22.25	23.00
		15	0	22.38	22.32	22.25	23.00
	Bandwidth	Modulation	RB size	RB offset	Channel/Frequency (MHz)		
131997/1712.5					132322/1745	132647/1777.5	
5MHz	QPSK	1	0	24.19	24.26	24.00	25.00
		1	13	24.06	23.83	23.94	25.00
		1	24	24.17	23.87	23.89	25.00
		12	0	23.49	23.27	23.24	24.00
		12	6	23.36	23.28	23.25	24.00
		12	13	23.60	23.30	23.27	24.00
		25	0	23.46	23.36	23.23	24.00
	16QAM	1	0	23.56	23.79	23.38	24.00
		1	13	23.54	23.63	23.28	24.00
		1	24	23.55	23.66	23.28	24.00
		12	0	22.49	22.22	22.24	23.00
		12	6	22.47	22.28	22.28	23.00
		12	13	22.44	22.28	22.29	23.00
		25	0	22.48	22.33	22.24	23.00
	64QAM	1	0	23.49	23.41	23.12	24.00
		1	13	23.35	23.26	23.01	24.00



Bandwidth	Modulation	RB size	RB offset	Channel/Frequency (MHz)			Tune-up Limit	
				132022/1715	132322/1745	132622/1775		
		1	24	23.53	23.18	22.92	24.00	
		12	0	22.36	22.28	22.34	23.00	
		12	6	22.38	22.30	22.32	23.00	
		12	13	22.36	22.29	22.21	23.00	
		25	0	22.36	22.28	22.20	23.00	
10MHz	QPSK	1	0	24.21	24.27	24.03	25.00	
		1	25	24.09	23.88	23.98	25.00	
		1	49	24.19	23.91	23.92	25.00	
		25	0	23.52	23.32	23.28	24.00	
		25	13	23.39	23.33	23.29	24.00	
		25	25	23.62	23.34	23.32	24.00	
		50	0	23.50	23.38	23.27	24.00	
	16QAM	1	0	23.58	23.82	23.40	24.00	
		1	25	23.57	23.67	23.31	24.00	
		1	49	23.58	23.68	23.31	24.00	
		25	0	22.52	22.27	22.28	23.00	
		25	13	22.49	22.32	22.31	23.00	
		25	25	22.47	22.33	22.33	23.00	
		50	0	22.51	22.38	22.28	23.00	
	64QAM	1	0	23.51	23.40	23.14	24.00	
		1	25	23.38	23.26	23.04	24.00	
		1	49	23.52	23.20	22.95	24.00	
		25	0	22.39	22.33	22.34	23.00	
		25	13	22.40	22.34	22.35	23.00	
		25	25	22.39	22.34	22.25	23.00	
		50	0	22.39	22.33	22.24	23.00	
	Bandwidth	Modulation	RB size	RB offset	Channel/Frequency (MHz)			Tune-up Limit
					132047/1717.5	132322/1745	132597/1772.5	
	15MHz	QPSK	1	0	24.20	24.23	24.01	25.00
			1	38	24.07	23.87	23.95	25.00
			1	74	24.16	23.86	23.88	25.00
			36	0	23.50	23.28	23.25	24.00
			36	18	23.36	23.28	23.25	24.00
36			39	23.59	23.31	23.28	24.00	
75			0	23.48	23.34	23.22	24.00	
16QAM		1	0	23.53	23.80	23.38	24.00	
		1	38	23.55	23.64	23.29	24.00	
		1	74	23.55	23.64	23.28	24.00	
		36	0	22.49	22.25	22.25	23.00	
		36	18	22.46	22.27	22.27	23.00	
		36	39	22.45	22.29	22.30	23.00	



Bandwidth	Modulation	RB size	RB offset	Channel/Frequency (MHz)			Tune-up Limit	
				132072/1720	132322/1745	132572/1770		
20MHz	64QAM	75	0	22.48	22.33	22.24	23.00	
		1	0	23.46	23.38	23.12	24.00	
		1	38	23.36	23.23	23.02	24.00	
		1	74	23.53	23.19	22.96	24.00	
		36	0	22.38	22.35	22.35	23.00	
		36	18	22.38	22.31	22.34	23.00	
		36	39	22.37	22.30	22.22	23.00	
		75	0	22.36	22.28	22.20	23.00	
	20MHz	QPSK	1	0	24.17	24.19	23.98	25.00
			1	50	24.06	23.83	23.93	25.00
			1	99	24.14	23.85	23.85	25.00
			50	0	23.47	23.23	23.21	24.00
			50	25	23.34	23.24	23.22	24.00
			50	50	23.56	23.26	23.24	24.00
			100	0	23.45	23.29	23.18	24.00
			16QAM	1	0	23.66	23.76	23.33
		1		50	23.51	23.62	23.25	24.00
		1		99	23.53	23.61	23.26	24.00
		50		0	22.46	22.21	22.22	23.00
		50		25	22.43	22.25	22.24	23.00
		50		50	22.42	22.24	22.26	23.00
		100		0	22.46	22.29	22.21	23.00
		64QAM		1	0	23.44	23.34	23.07
			1	50	23.32	23.21	22.98	24.00
			1	99	23.47	23.13	22.90	24.00
			50	0	22.33	22.27	22.28	23.00
			50	25	22.34	22.27	22.28	23.00
			50	50	22.34	22.25	22.18	23.00
100			0	22.34	22.24	22.17	23.00	

LTE FDD Band 66 Level 6				Conducted Power(dBm)			Tune-up Limit
Bandwidth	Modulation	RB size	RB offset	Channel/Frequency (MHz)			
				131979/1710.7	132322/1745	132665/1779.3	
1.4MHz	QPSK	1	0	23.09	23.12	23.11	23.50
		1	2	23.07	22.94	23.07	23.50
		1	5	23.22	23.14	23.07	23.50
		3	0	23.16	23.02	23.18	23.50
		3	2	23.09	23.16	23.16	23.50
		3	3	23.10	23.09	23.19	23.50
		6	0	22.20	22.29	22.27	22.50



	16QAM	1	0	22.19	22.34	22.27	22.50	
		1	2	22.17	22.20	22.13	22.50	
		1	5	22.19	22.22	22.17	22.50	
		3	0	22.26	22.28	22.23	22.50	
		3	2	22.20	22.22	22.16	22.50	
		3	3	22.25	22.31	22.21	22.50	
		6	0	21.34	21.41	21.35	21.50	
	64QAM	1	0	22.35	22.37	22.30	22.50	
		1	2	22.02	22.05	22.00	22.50	
		1	5	22.05	22.13	22.03	22.50	
		3	0	22.25	22.23	22.18	22.50	
		3	2	22.24	22.26	22.20	22.50	
		3	3	22.25	22.31	22.21	22.50	
		6	0	21.22	21.29	21.23	21.50	
Bandwidth	Modulation	RB size	RB offset	Channel/Frequency (MHz)			Tune-up Limit	
				131987/1711.5	132322/1745	132657/1778.5		
3MHz	QPSK	1	0	23.11	23.16	23.14	23.50	
		1	7	23.05	22.97	23.11	23.50	
		1	14	23.25	23.19	23.11	23.50	
		8	0	22.26	22.14	22.31	22.50	
		8	4	22.21	22.26	22.28	22.50	
		8	7	22.20	22.20	22.29	22.50	
		15	0	22.20	22.33	22.30	22.50	
	16QAM	1	0	22.22	22.36	22.30	22.50	
		1	7	22.20	22.20	22.17	22.50	
		1	14	22.21	22.26	22.20	22.50	
		8	0	21.37	21.41	21.35	21.50	
		8	4	21.31	21.35	21.28	21.50	
		8	7	21.35	21.43	21.34	21.50	
		15	0	21.37	21.45	21.38	21.50	
	64QAM	1	0	22.38	22.39	22.33	22.50	
		1	7	22.05	22.05	22.02	22.50	
		1	14	22.07	22.12	22.06	22.50	
		8	0	21.36	21.36	21.30	21.50	
		8	4	21.35	21.39	21.32	21.50	
		8	7	21.35	21.43	21.34	21.50	
		15	0	21.25	21.33	21.26	21.50	
	Bandwidth	Modulation	RB size	RB offset	Channel/Frequency (MHz)			Tune-up Limit
					131997/1712.5	132322/1745	132647/1777.5	
	5MHz	QPSK	1	0	23.09	23.11	23.11	23.50
			1	13	23.04	22.97	23.09	23.50
			1	24	23.21	23.13	23.06	23.50
			12	0	22.24	22.10	22.28	22.50



		12	6	22.19	22.22	22.23	22.50	
		12	13	22.17	22.19	22.26	22.50	
		25	0	22.22	22.30	22.27	22.50	
	16QAM		1	0	22.16	22.33	22.27	22.50
			1	13	22.18	22.19	22.15	22.50
			1	24	22.18	22.22	22.16	22.50
			12	0	21.35	21.40	21.33	21.50
			12	6	21.27	21.29	21.23	21.50
			12	13	21.33	21.39	21.31	21.50
			25	0	21.35	21.41	21.33	21.50
	64QAM		1	0	22.32	22.36	22.30	22.50
			1	13	22.03	22.04	22.00	22.50
			1	24	22.08	22.11	22.06	22.50
			12	0	21.36	21.39	21.32	21.50
			12	6	21.32	21.35	21.30	21.50
12			13	21.33	21.39	21.31	21.50	
25			0	21.23	21.29	21.21	21.50	
Bandwidth	Modulation	RB size	RB offset	Channel/Frequency (MHz)			Tune-up Limit	
				132022/1715	132322/1745	132622/1775		
10MHz	QPSK	1	0	23.08	23.14	23.10	23.50	
		1	25	23.03	22.93	23.08	23.50	
		1	49	23.22	23.14	23.07	23.50	
		25	0	22.23	22.09	22.27	22.50	
		25	13	22.19	22.22	22.23	22.50	
		25	25	22.18	22.18	22.25	22.50	
		50	0	22.20	22.32	22.28	22.50	
	16QAM		1	0	22.19	22.32	22.27	22.50
			1	25	22.17	22.18	22.14	22.50
			1	49	22.18	22.24	22.16	22.50
			25	0	21.35	21.37	21.32	21.50
			25	13	21.28	21.30	21.24	21.50
			25	25	21.32	21.38	21.30	21.50
			50	0	21.35	21.41	21.33	21.50
	64QAM		1	0	22.35	22.39	22.30	22.50
			1	25	22.02	22.07	21.99	22.50
			1	49	22.08	22.10	22.02	22.50
			25	0	21.34	21.32	21.31	21.50
			25	13	21.32	21.34	21.28	21.50
			25	25	21.32	21.38	21.30	21.50
			50	0	21.23	21.29	21.21	21.50
Bandwidth	Modulation	RB size	RB offset	Channel/Frequency (MHz)			Tune-up Limit	
				132047/1717.5	132322/1745	132597/1772.5		
15MHz	QPSK	1	0	23.10	23.15	23.13	23.50	



		1	38	23.06	22.98	23.12	23.50	
		1	74	23.24	23.18	23.10	23.50	
		36	0	22.26	22.14	22.31	22.50	
		36	18	22.22	22.27	22.27	22.50	
		36	39	22.20	22.22	22.30	22.50	
		75	0	22.24	22.34	22.32	22.50	
	16QAM	1	0	22.21	22.35	22.29	22.50	
		1	38	22.20	22.22	22.17	22.50	
		1	74	22.21	22.26	22.19	22.50	
		36	0	21.38	21.42	21.36	21.50	
		36	18	21.30	21.34	21.27	21.50	
		36	39	21.35	21.43	21.34	21.50	
	64QAM	75	0	21.38	21.46	21.37	21.50	
		1	0	22.37	22.38	22.32	22.50	
		1	38	22.05	22.07	22.02	22.50	
		1	74	22.07	22.12	22.05	22.50	
		36	0	21.37	21.37	21.31	21.50	
		36	18	21.34	21.38	21.31	21.50	
	Bandwidth	Modulation	RB size	RB offset	Channel/Frequency (MHz)			Tune-up Limit
					132072/1720	132322/1745	132572/1770	
	20MHz	QPSK	1	0	23.06	23.07	23.08	23.50
1			50	23.03	22.93	23.07	23.50	
1			99	23.19	23.12	23.03	23.50	
50			0	22.21	22.05	22.24	22.50	
50			25	22.17	22.18	22.20	22.50	
50			50	22.14	22.14	22.22	22.50	
16QAM		100	0	22.19	22.25	22.23	22.50	
		1	0	22.27	22.29	22.22	22.50	
		1	50	22.14	22.17	22.11	22.50	
		1	99	22.16	22.19	22.14	22.50	
		50	0	21.32	21.36	21.30	21.50	
		50	25	21.24	21.27	21.20	21.50	
64QAM		50	50	21.30	21.34	21.27	21.50	
		100	0	21.33	21.37	21.30	21.50	
		1	0	22.30	22.32	22.25	22.50	
		1	50	21.99	22.02	21.96	22.50	
		1	99	22.02	22.05	22.00	22.50	
		50	0	21.31	21.31	21.25	21.50	
			50	25	21.28	21.31	21.24	21.50
			50	50	21.30	21.34	21.27	21.50
			100	0	21.21	21.25	21.18	21.50



9.1.1 LTE CA

CA Combination	Test Scenario	Modulation	PCC (UL)						SCC1 (UL)					Conducted Power (dbm)	Tune up (dbm)
			PCC Band	PCC BW (MHz)	PCC UL RB size	PCC UL RB offset	PCC UL Channel	PCC DL Channel	SCC Band	SCC BW (MHz)	SCC UL Channel	SCC UL RB size	SCC UL RB offset		
CA_5B	Normal Power	QPSK	5	10	1	49	20450	2450	5	10	20549	1	0	24.30	25.00
		QPSK	5	10	1	0	20525	2525	5	10	20426	1	49	24.19	25.00
		QPSK	5	10	1	49	20525	2525	5	10	20624	1	0	24.27	25.00
		QPSK	5	10	1	0	20600	2600	5	10	20501	1	49	24.25	25.00

CA Combination	Test Scenario	Modulation	PCC (UL)						SCC1 (UL)					Conducted Power (dbm)	Tune up (dbm)
			PCC Band	PCC BW (MHz)	PCC UL RB size	PCC UL RB offset	PCC UL Channel	PCC DL Channel	SCC Band	SCC BW (MHz)	SCC UL Channel	SCC UL RB size	SCC UL RB offset		
CA_66C	Normal Power	QPSK	66	20	1	99	132072	132072	66	20	132270	1	0	23.82	25.00
		QPSK	66	20	1	99	132322	132322	66	20	132520	1	0	23.86	25.00
		QPSK	66	20	1	0	132322	132322	66	20	132124	1	99	23.75	25.00
		QPSK	66	20	1	99	132572	132572	66	20	132374	1	0	23.80	25.00
CA_66C	Level 6	QPSK	66	20	1	99	132072	132072	66	20	132270	1	0	22.75	23.50
		QPSK	66	20	1	99	132322	132322	66	20	132520	1	0	22.83	23.50
		QPSK	66	20	1	0	132322	132322	66	20	132124	1	99	22.74	23.50
		QPSK	66	20	1	99	132572	132572	66	20	132374	1	0	22.76	23.50
CA_66B	Normal Power	QPSK	66	10	1	49	132022	132022	66	10	132121	1	0	23.85	25.00
		QPSK	66	10	1	49	132322	132322	66	10	132421	1	0	23.81	25.00
		QPSK	66	10	1	0	132322	132322	66	10	132223	1	49	23.76	25.00
		QPSK	66	10	1	49	132622	132622	66	10	132523	1	0	23.74	25.00
CA_66B	Level 6	QPSK	66	10	1	49	132022	132022	66	10	132121	1	0	22.72	23.50
		QPSK	66	10	1	49	132322	132322	66	10	132421	1	0	22.68	23.50
		QPSK	66	10	1	0	132322	132322	66	10	132223	1	49	22.62	23.50
		QPSK	66	10	1	49	132622	132622	66	10	132523	1	0	22.79	23.50

9.2 EN-DC Mode

The following tests were conducted according to the test requirements outlined in section 6.2 of the 3GPP TS 138.521-1 specification.

UE Power Class: 3 (23 +/- 2dBm). The allowed Maximum Power Reduction (MPR) for the maximum output power due to higher order modulation and transmit bandwidth configuration (resource blocks) is specified in Table 6.2.3-1 of the 3GPP TS138.521-1.

Table 6.2.2.3-1: Maximum Power Reduction (MPR) for Power 3

Modulation	MPR (dB)		
	Edge RB allocations	Outer RB allocations	Inner RB allocations
DFT-s-OFDM PI/2 BPSK	$\leq 3.5^1$	$\leq 1.2^1$	$\leq 0.2^1$
	$\leq 0.5^2$		0^2
DFT-s-OFDM QPSK	≤ 1		0
DFT-s-OFDM 16 QAM	≤ 2		≤ 1
DFT-s-OFDM 64 QAM		≤ 2.5	
DFT-s-OFDM 256 QAM		≤ 4.5	
CP-OFDM QPSK	≤ 3		≤ 1.5
CP-OFDM 16 QAM	≤ 3		≤ 2
CP-OFDM 64 QAM		≤ 3.5	
CP-OFDM 256 QAM		≤ 6.5	

NOTE 1: Applicable for UE operating in TDD mode with PI/2 BPSK modulation and UE indicates support for UE capability *powerBoosting-pi2BPSK* and if the IE *powerBoostPi2BPSK* is set to 1 and 40 % or less slots in radio frame are used for UL transmission for bands n40, n41, n77, n78 and n79. The reference power of 0dB MPR is 26dBm.

NOTE 2: Applicable for UE operating in FDD mode, or in TDD mode in bands other than n40, n41, n77, n78 and n79 and if the IE *powerBoostPi2BPSK* is set to 0 and if more than 40% of slots in radio frame are used for UL transmission for bands n40, n41, n77, n78 and n79.

The allowed A-MPR values specified below in Table 6.2.3.3.1-1 of 3GPP TS138.521-1 are in addition to the allowed MPR requirements. All the measurements below were performed with A-MPR disabled, by using Network Signaling Value of "NS_01"

Table 6.2.3.3.1-1: Additional maximum power reduction (A-MPR)

Network Signalling label	Requirements (subclause)	NR Band	Channel bandwidth (MHz)	Resources Blocks (N_{RB})	A-MPR (dB)
NS_01		Table 5.2-1	5, 10, 15, 20, 25, 30, 40, 50, 60, 80, 90, 100	Table 5.3.2-1	N/A

EN-DC Antenna Configuration

	Band	LTE Band	NR Band	Antenna 4	Antenna 6	Antenna 7
EN-DC	EN-DC_5A_n2	LTE 5	n2	LTE	--	NR
	EN-DC_13A_n2	LTE 13	n2	LTE	--	NR
	EN-DC_66A_n2	LTE 66	n2	--	LTE	NR
	EN-DC_2A_n5	LTE 2	n5	NR	--	LTE
	EN-DC_66A_n5	LTE 66	n5	NR	--	LTE
	EN-DC_2A_n66	LTE 2	n66	--	LTE	NR
	EN-DC_5A_n66	LTE 5	n66	LTE	--	NR
	EN-DC_13A_n66	LTE 13	n66	LTE	--	NR

Note:

- 1) For EN-DC DPS function, considering two conditions, one is the maximum total power tend to 5G NR bands (5G NR maximum SAR), the other is the maximum total tend to LTE bands (5G NR minimum SAR), summed 5G NR(maximum power) SAR or LTE (maximum power) SAR as EN-DC SAR to consider simultaneous transmission evaluation.
- 2) The EN-DC mode maximum power for LTE are same as LTE standalone mode, so this section only list 5G NR conducted power.

9.2.1 LTE (EN-DC)

LTE FDD Band 2 Normal Power				Conducted Power(dBm)			Tune-up Limit
Bandwidth	Modulation	RB size	RB offset	Channel/Frequency (MHz)			
				18607/1850.7	18900/1880	19193/1909.3	
1.4MHz	QPSK	1	0	23.05	23.10	23.04	24.00
		1	2	23.18	23.23	23.19	24.00
		1	5	23.27	23.31	23.24	24.00
		3	0	23.51	23.47	23.54	24.00
		3	2	23.54	23.56	23.47	24.00
		3	3	23.68	23.64	23.59	24.00
		6	0	22.62	22.56	22.62	23.00
	16QAM	1	0	22.26	22.25	22.26	23.00
		1	2	22.24	22.28	22.20	23.00
		1	5	22.42	22.48	22.45	23.00
		3	0	22.67	22.70	22.73	23.00
		3	2	22.73	22.80	22.71	23.00
		3	3	22.76	22.77	22.80	23.00
	64QAM	6	0	21.79	21.83	21.85	22.00
		1	0	22.44	22.49	22.46	23.00
1		2	22.38	22.44	22.47	23.00	
		1	5	22.33	22.56	22.38	23.00



Bandwidth	Modulation	RB size	RB offset	Channel/Frequency (MHz)			Tune-up Limit	
				18615/1851.5	18900/1880	19185/1908.5		
		3	0	22.77	22.67	22.73	23.00	
		3	2	22.80	22.80	22.77	23.00	
		3	3	22.77	22.87	22.82	23.00	
		6	0	21.80	21.88	21.80	22.00	
3MHz	QPSK	1	0	23.07	23.14	23.07	24.00	
		1	7	23.16	23.26	23.23	24.00	
		1	14	23.30	23.36	23.28	24.00	
		8	0	22.61	22.59	22.67	23.00	
		8	4	22.66	22.66	22.59	23.00	
		8	7	22.78	22.75	22.69	23.00	
		15	0	22.62	22.60	22.65	23.00	
	16QAM	1	0	22.29	22.27	22.29	23.00	
		1	7	22.27	22.28	22.24	23.00	
		1	14	22.44	22.52	22.48	23.00	
		8	0	21.78	21.83	21.85	22.00	
		8	4	21.84	21.93	21.83	22.00	
		8	7	21.86	21.76	21.80	22.00	
		15	0	21.82	21.87	21.88	22.00	
	64QAM	1	0	22.47	22.51	22.49	23.00	
		1	7	22.41	22.44	22.49	23.00	
		1	14	22.35	22.55	22.41	23.00	
		8	0	21.88	21.80	21.85	22.00	
		8	4	21.91	21.80	21.76	22.00	
		8	7	21.87	21.86	21.82	22.00	
		15	0	21.83	21.79	21.82	22.00	
	Bandwidth	Modulation	RB size	RB offset	Channel/Frequency (MHz)			Tune-up Limit
					18625/1852.5	18900/1880	19175/1907.5	
	5MHz	QPSK	1	0	23.04	23.12	23.03	24.00
1			13	23.14	23.22	23.20	24.00	
1			24	23.27	23.31	23.24	24.00	
12			0	22.58	22.54	22.63	23.00	
12			6	22.64	22.62	22.54	23.00	
12			13	22.76	22.73	22.65	23.00	
25			0	22.62	22.59	22.63	23.00	
16QAM		1	0	22.26	22.23	22.26	23.00	
		1	13	22.24	22.26	22.21	23.00	
		1	24	22.41	22.50	22.44	23.00	
		12	0	21.76	21.79	21.68	22.00	
		12	6	21.81	21.74	21.79	22.00	
		12	13	21.83	21.84	21.75	22.00	
		25	0	21.80	21.83	21.83	22.00	



Bandwidth	Modulation	RB size	RB offset	Channel/Frequency (MHz)			Tune-up Limit	
				18650/1855	18900/1880	19150/1905		
	64QAM	1	0	22.44	22.51	22.46	23.00	
		1	13	22.38	22.46	22.46	23.00	
		1	24	22.36	22.53	22.37	23.00	
		12	0	21.86	21.76	21.86	22.00	
		12	6	21.88	21.88	21.85	22.00	
		12	13	21.84	21.80	21.77	22.00	
		25	0	21.80	21.74	21.77	22.00	
10MHz	QPSK	1	0	23.06	23.13	23.06	24.00	
		1	25	23.17	23.27	23.24	24.00	
		1	49	23.29	23.35	23.27	24.00	
		25	0	22.61	22.59	22.67	23.00	
		25	13	22.67	22.67	22.58	23.00	
		25	25	22.78	22.77	22.70	23.00	
		50	0	22.66	22.61	22.67	23.00	
	16QAM	1	0	22.28	22.26	22.28	23.00	
		1	25	22.27	22.30	22.24	23.00	
		1	49	22.44	22.52	22.47	23.00	
		25	0	21.79	21.84	21.86	22.00	
		25	13	21.83	21.78	21.82	22.00	
		25	25	21.86	21.89	21.79	22.00	
		50	0	21.83	21.74	21.73	22.00	
	64QAM	1	0	22.46	22.50	22.48	23.00	
		1	25	22.41	22.46	22.49	23.00	
		1	49	22.35	22.55	22.40	23.00	
		25	0	21.75	21.81	21.86	22.00	
		25	13	21.76	21.78	21.88	22.00	
		25	25	21.87	21.85	21.81	22.00	
		50	0	21.83	21.79	21.81	22.00	
	Bandwidth	Modulation	RB size	RB offset	Channel/Frequency (MHz)			Tune-up Limit
					18675/1857.5	18900/1880	19125/1902.5	
	15MHz	QPSK	1	0	23.05	23.09	23.04	24.00
			1	38	23.15	23.26	23.21	24.00
			1	74	23.26	23.30	23.23	24.00
			36	0	22.59	22.55	22.64	23.00
			36	18	22.64	22.62	22.54	23.00
36			39	22.75	22.74	22.66	23.00	
75			0	22.64	22.57	22.62	23.00	
16QAM		1	0	22.23	22.24	22.26	23.00	
		1	38	22.25	22.27	22.22	23.00	
		1	74	22.41	22.48	22.44	23.00	
		36	0	21.76	21.82	21.83	22.00	



Bandwidth	Modulation	RB size	RB offset	Channel/Frequency (MHz)			Tune-up Limit	
				18700/1860	18900/1880	19100/1900		
20MHz	64QAM	36	18	21.80	21.87	21.78	22.00	
		36	39	21.84	21.85	21.80	22.00	
		75	0	21.80	21.83	21.83	22.00	
		1	0	22.41	22.48	22.46	23.00	
		1	38	22.39	22.43	22.47	23.00	
		1	74	22.36	22.54	22.41	23.00	
		36	0	21.88	21.83	21.87	22.00	
		36	18	21.88	21.89	21.87	22.00	
		36	39	21.85	21.85	21.82	22.00	
	75	0	21.84	21.88	21.81	22.00		
	20MHz	QPSK	1	0	23.02	23.05	23.01	24.00
			1	50	23.14	23.22	23.19	24.00
			1	99	23.24	23.29	23.20	24.00
			50	0	22.56	22.50	22.60	23.00
			50	25	22.62	22.58	22.51	23.00
			50	50	22.72	22.69	22.62	23.00
			100	0	22.61	22.52	22.58	23.00
		16QAM	1	0	22.27	22.20	22.21	23.00
1			50	22.21	22.25	22.18	23.00	
1			99	22.39	22.45	22.42	23.00	
50			0	21.73	21.78	21.80	22.00	
50			25	21.77	21.85	21.75	22.00	
50			50	21.81	21.80	21.86	22.00	
100			0	21.78	21.79	21.80	22.00	
64QAM		1	0	22.39	22.44	22.41	23.00	
		1	50	22.35	22.41	22.43	23.00	
		1	99	22.30	22.48	22.35	23.00	
		50	0	21.83	21.75	21.80	22.00	
	50	25	21.84	21.85	21.81	22.00		
	50	50	21.82	21.90	21.88	22.00		
	100	0	21.92	21.84	21.88	22.00		

LTE FDD Band 2 Level 2				Conducted Power(dBm)			Tune-up Limit
Bandwidth	Modulation	RB size	RB offset	Channel/Frequency (MHz)			
				18607/1850.7	18900/1880	19193/1909.3	
1.4MHz	QPSK	1	0	23.36	23.20	23.21	23.50
		1	2	23.38	23.14	23.15	23.50
		1	5	23.28	23.11	23.18	23.50
		3	0	23.37	23.29	23.14	23.50
		3	2	23.33	23.33	23.34	23.50



		3	3	23.36	23.25	23.34	23.50
		6	0	22.29	22.29	22.29	22.50
	16QAM	1	0	22.37	22.30	22.37	22.50
		1	2	22.35	22.36	22.29	22.50
		1	5	22.37	22.33	22.31	22.50
		3	0	22.22	22.27	22.21	22.50
		3	2	22.35	22.27	22.42	22.50
		3	3	22.31	22.27	22.35	22.50
		6	0	21.27	21.24	21.36	21.50
	64QAM	1	0	22.30	22.32	22.29	22.50
		1	2	22.32	22.36	22.30	22.50
		1	5	22.20	22.36	22.38	22.50
		3	0	22.22	22.22	22.20	22.50
		3	2	22.36	22.12	22.33	22.50
		3	3	22.32	22.41	22.33	22.50
6	0	21.36	21.30	21.31	21.50		
Bandwidth	Modulation	RB size	RB offset	Channel/Frequency (MHz)			Tune-up Limit
				18615/1851.5	18900/1880	19185/1908.5	
3MHz	QPSK	1	0	23.38	23.24	23.24	23.50
		1	7	23.36	23.17	23.19	23.50
		1	14	23.31	23.16	23.22	23.50
		8	0	22.35	22.29	22.27	22.50
		8	4	22.33	22.31	22.34	22.50
		8	7	22.34	22.36	22.32	22.50
		15	0	22.30	22.33	22.32	22.50
	16QAM	1	0	22.35	22.33	22.34	22.50
		1	7	22.32	22.37	22.31	22.50
		1	14	22.29	22.38	22.35	22.50
		8	0	21.33	21.28	21.33	21.50
		8	4	21.34	21.40	21.34	21.50
		8	7	21.29	21.39	21.36	21.50
		15	0	21.31	21.28	21.39	21.50
	64QAM	1	0	22.34	22.35	22.32	22.50
		1	7	22.35	22.37	22.32	22.50
		1	14	22.22	22.35	22.29	22.50
		8	0	21.33	21.35	21.32	21.50
		8	4	21.35	21.25	21.33	21.50
		8	7	21.30	21.36	21.34	21.50
		15	0	21.39	21.34	21.34	21.50
Bandwidth	Modulation	RB size	RB offset	Channel/Frequency (MHz)			Tune-up Limit
				18625/1852.5	18900/1880	19175/1907.5	
5MHz	QPSK	1	0	23.35	23.22	23.20	23.50
		1	13	23.34	23.13	23.16	23.50



		1	24	23.28	23.11	23.18	23.50	
		12	0	22.33	22.36	22.23	22.50	
		12	6	22.32	22.39	22.30	22.50	
		12	13	22.33	22.34	22.29	22.50	
		25	0	22.31	22.32	22.30	22.50	
	16QAM	1	0	22.39	22.30	22.34	22.50	
		1	13	22.37	22.36	22.32	22.50	
		1	24	22.38	22.37	22.32	22.50	
		12	0	21.31	21.36	21.30	21.50	
		12	6	21.32	21.35	21.39	21.50	
		12	13	21.38	21.34	21.33	21.50	
		25	0	21.30	21.24	21.34	21.50	
	64QAM	1	0	22.32	22.36	22.29	22.50	
		1	13	22.32	22.40	22.29	22.50	
		1	24	22.23	22.33	22.37	22.50	
		12	0	21.31	21.31	21.33	21.50	
		12	6	21.33	21.20	21.30	21.50	
		12	13	21.28	21.37	21.31	21.50	
		25	0	21.37	21.30	21.29	21.50	
	Bandwidth	Modulation	RB size	RB offset	Channel/Frequency (MHz)			Tune-up Limit
					18650/1855	18900/1880	19150/1905	
10MHz	QPSK	1	0	23.37	23.23	23.23	23.50	
		1	25	23.37	23.18	23.20	23.50	
		1	49	23.30	23.15	23.21	23.50	
		25	0	22.37	22.30	22.27	22.50	
		25	13	22.31	22.38	22.34	22.50	
		25	25	22.36	22.38	22.35	22.50	
		50	0	22.36	22.24	22.24	22.50	
	16QAM	1	0	22.36	22.34	22.38	22.50	
		1	25	22.37	22.37	22.36	22.50	
		1	49	22.32	22.35	22.36	22.50	
		25	0	21.24	21.31	21.24	21.50	
		25	13	21.35	21.29	21.37	21.50	
		25	25	21.31	21.29	21.38	21.50	
		50	0	21.34	21.29	21.28	21.50	
	64QAM	1	0	22.35	22.46	22.21	22.50	
		1	25	22.35	22.33	22.32	22.50	
		1	49	22.22	22.35	22.31	22.50	
		25	0	21.34	21.36	21.33	21.50	
		25	13	21.36	21.24	21.34	21.50	
		25	25	21.32	21.31	21.36	21.50	
		50	0	21.30	21.35	21.33	21.50	
Bandwidth	Modulation	RB size	RB offset	Channel/Frequency (MHz)			Tune-up	



Bandwidth	Modulation	RB size	RB offset	18675/1857.5	18900/1880	19125/1902.5	Limit
				Channel/Frequency (MHz)			
				18700/1860	18900/1880	19100/1900	Tune-up Limit
15MHz	QPSK	1	0	23.36	23.19	23.21	23.50
		1	38	23.35	23.17	23.17	23.50
		1	74	23.27	23.10	23.17	23.50
		36	0	22.40	22.37	22.24	22.50
		36	18	22.35	22.39	22.30	22.50
		36	39	22.34	22.35	22.38	22.50
		75	0	22.44	22.30	22.29	22.50
	16QAM	1	0	22.38	22.35	22.38	22.50
		1	38	22.32	22.30	22.35	22.50
		1	74	22.35	22.31	22.43	22.50
		36	0	21.31	21.39	21.31	21.50
		36	18	21.42	21.34	21.38	21.50
		36	39	21.39	21.35	21.45	21.50
		75	0	21.37	21.24	21.34	21.50
	64QAM	1	0	22.40	22.35	22.29	22.50
		1	38	22.33	22.36	22.30	22.50
		1	74	22.23	22.34	22.27	22.50
		36	0	21.33	21.38	21.34	21.50
		36	18	21.27	21.21	21.34	21.50
		36	39	21.40	21.32	21.36	21.50
		75	0	21.37	21.30	21.29	21.50
20MHz	QPSK	1	0	23.33	23.15	23.18	23.50
		1	50	23.34	23.13	23.15	23.50
		1	99	23.25	23.09	23.14	23.50
		50	0	22.42	22.32	22.20	22.50
		50	25	22.41	22.35	22.38	22.50
		50	50	22.40	22.30	22.37	22.50
		100	0	22.41	22.25	22.25	22.50
	16QAM	1	0	22.36	22.38	22.33	22.50
		1	50	22.36	22.38	22.28	22.50
		1	99	22.27	22.31	22.29	22.50
		50	0	21.28	21.35	21.28	21.50
		50	25	21.27	21.32	21.35	21.50
		50	50	21.36	21.30	21.29	21.50
		100	0	21.39	21.20	21.31	21.50
	64QAM	1	0	22.38	22.28	22.24	22.50
		1	50	22.29	22.34	22.26	22.50
		1	99	22.17	22.28	22.35	22.50
		50	0	21.28	21.30	21.27	21.50
		50	25	21.40	21.17	21.37	21.50



		50	50	21.37	21.36	21.27	21.50
		100	0	21.35	21.26	21.26	21.50

LTE FDD Band 2 Level 4				Conducted Power(dBm)			Tune-up Limit
Bandwidth	Modulation	RB size	RB offset	Channel/Frequency (MHz)			
				18607/1850.7	18900/1880	19193/1909.3	
1.4MHz	QPSK	1	0	19.25	19.25	19.22	19.50
		1	2	19.23	19.19	19.20	19.50
		1	5	19.19	19.25	19.18	19.50
		3	0	19.16	19.19	19.13	19.50
		3	2	19.21	19.21	19.35	19.50
		3	3	19.33	19.25	19.20	19.50
		6	0	18.22	18.25	18.32	18.50
	16QAM	1	0	18.31	18.28	18.31	18.50
		1	2	18.34	18.31	18.25	18.50
		1	5	18.23	18.31	18.20	18.50
		3	0	18.14	18.15	18.19	18.50
		3	2	18.22	18.23	18.34	18.50
		3	3	18.26	18.29	18.37	18.50
		6	0	17.25	17.29	17.27	17.50
	64QAM	1	0	18.31	18.38	18.31	18.50
		1	2	18.28	18.28	18.37	18.50
		1	5	18.22	18.22	18.33	18.50
		3	0	17.94	18.12	18.19	18.50
		3	2	18.26	18.26	18.30	18.50
		3	3	18.23	18.27	18.36	18.50
		6	0	17.27	17.23	17.33	17.50

Bandwidth	Modulation	RB size	RB offset	Channel/Frequency (MHz)			Tune-up Limit
				18615/1851.5	18900/1880	19185/1908.5	
3MHz	QPSK	1	0	19.27	19.29	19.25	19.50
		1	7	19.21	19.22	19.24	19.50
		1	14	19.22	19.30	19.22	19.50
		8	0	18.26	18.31	18.26	18.50
		8	4	18.33	18.31	18.31	18.50
		8	7	18.27	18.36	18.29	18.50
		15	0	18.22	18.29	18.35	18.50
	16QAM	1	0	18.31	18.45	18.33	18.50
		1	7	18.30	18.31	18.28	18.50
		1	14	18.28	18.34	18.23	18.50
		8	0	17.25	17.28	17.31	17.50
		8	4	17.33	17.36	17.30	17.50
		8	7	17.36	17.25	17.34	17.50



Bandwidth	Modulation	RB size	RB offset	Channel/Frequency (MHz)			Tune-up Limit	
				18625/1852.5	18900/1880	19175/1907.5		
	64QAM	15	0	17.28	17.33	17.30	17.50	
		1	0	18.33	18.24	18.33	18.50	
		1	7	18.30	18.28	18.39	18.50	
		1	14	18.24	18.21	18.29	18.50	
		8	0	17.05	17.25	17.31	17.50	
		8	4	17.37	17.39	17.26	17.50	
		8	7	17.33	17.35	17.33	17.50	
		15	0	17.30	17.27	17.36	17.50	
5MHz	QPSK	1	0	19.24	19.27	19.21	19.50	
		1	13	19.19	19.18	19.21	19.50	
		1	24	19.19	19.25	19.18	19.50	
		12	0	18.23	18.26	18.22	18.50	
		12	6	18.31	18.27	18.28	18.50	
		12	13	18.29	18.34	18.29	18.50	
		25	0	18.22	18.28	18.33	18.50	
	16QAM	1	0	18.32	18.29	18.34	18.50	
		1	13	18.30	18.29	18.29	18.50	
		1	24	18.37	18.36	18.19	18.50	
		12	0	17.23	17.24	17.28	17.50	
		12	6	17.30	17.31	17.30	17.50	
		12	13	17.33	17.36	17.34	17.50	
		25	0	17.26	17.29	17.25	17.50	
	64QAM	1	0	18.34	18.28	18.34	18.50	
		1	13	18.31	18.30	18.36	18.50	
		1	24	18.25	18.19	18.35	18.50	
		12	0	17.03	17.21	17.32	17.50	
		12	6	17.34	17.34	17.38	17.50	
		12	13	17.30	17.34	17.33	17.50	
		25	0	17.28	17.23	17.31	17.50	
	Bandwidth	Modulation	RB size	RB offset	Channel/Frequency (MHz)			Tune-up Limit
					18650/1855	18900/1880	19150/1905	
	10MHz	QPSK	1	0	19.26	19.28	19.24	19.50
1			25	19.22	19.23	19.25	19.50	
1			49	19.21	19.29	19.21	19.50	
25			0	18.26	18.31	18.26	18.50	
25			13	18.34	18.32	18.35	18.50	
25			25	18.43	18.38	18.35	18.50	
50			0	18.15	18.30	18.26	18.50	
16QAM		1	0	18.36	18.33	18.37	18.50	
		1	25	18.35	18.33	18.33	18.50	
	1	49	18.29	18.39	18.22	18.50		



	64QAM	25	0	17.26	17.29	17.32	17.50
		25	13	17.32	17.35	17.34	17.50
		25	25	17.36	17.30	17.33	17.50
		50	0	17.29	17.34	17.29	17.50
		1	0	18.37	18.39	18.37	18.50
		1	25	18.35	18.30	18.28	18.50
		1	49	18.24	18.21	18.39	18.50
		25	0	17.06	17.26	17.32	17.50
		25	13	17.36	17.38	17.30	17.50
		25	25	17.33	17.28	17.38	17.50
50	0	17.31	17.28	17.35	17.50		
Bandwidth	Modulation	RB size	RB offset	Channel/Frequency (MHz)			Tune-up Limit
				18675/1857.5	18900/1880	19125/1902.5	
15MHz	QPSK	1	0	19.25	19.24	19.22	19.50
		1	38	19.20	19.22	19.22	19.50
		1	74	19.18	19.24	19.17	19.50
		36	0	18.24	18.27	18.23	18.50
		36	18	18.31	18.27	18.31	18.50
		36	39	18.29	18.35	18.31	18.50
		75	0	18.24	18.26	18.32	18.50
	16QAM	1	0	18.37	18.31	18.35	18.50
		1	38	18.39	18.19	18.31	18.50
		1	74	18.37	18.35	18.19	18.50
		36	0	17.23	17.27	17.29	17.50
		36	18	17.29	17.30	17.27	17.50
		36	39	17.23	17.26	17.20	17.50
		75	0	17.26	17.29	17.25	17.50
	64QAM	1	0	18.30	18.26	18.33	18.50
		1	38	18.33	18.27	18.37	18.50
		1	74	18.25	18.20	18.35	18.50
		36	0	17.05	17.28	17.33	17.50
		36	18	17.34	17.35	17.40	17.50
		36	39	17.31	17.35	17.35	17.50
		75	0	17.28	17.23	17.31	17.50
Bandwidth	Modulation	RB size	RB offset	Channel/Frequency (MHz)			Tune-up Limit
				18700/1860	18900/1880	19100/1900	
20MHz	QPSK	1	0	19.22	19.20	19.19	19.50
		1	50	19.19	19.18	19.20	19.50
		1	99	19.16	19.23	19.14	19.50
		50	0	18.21	18.22	18.19	18.50
		50	25	18.29	18.23	18.39	18.50
		50	50	18.37	18.30	18.38	18.50
		100	0	18.21	18.21	18.28	18.50



	16QAM	1	0	18.28	18.38	18.41	18.50
		1	50	18.46	18.28	18.38	18.50
		1	99	18.35	18.28	18.17	18.50
		50	0	17.20	17.23	17.26	17.50
		50	25	17.26	17.28	17.38	17.50
		50	50	17.31	17.32	17.35	17.50
		100	0	17.24	17.25	17.22	17.50
	64QAM	1	0	18.41	18.33	18.41	18.50
		1	50	18.29	18.25	18.33	18.50
		1	99	18.19	18.14	18.45	18.50
		50	0	17.00	17.20	17.26	17.50
		50	25	17.30	17.31	17.34	17.50
		50	50	17.28	17.30	17.31	17.50
		100	0	17.26	17.19	17.28	17.50

LTE FDD Band 5 Normal Power				Conducted Power(dBm)			Tune-up Limit
Bandwidth	Modulation	RB size	RB offset	Channel/Frequency (MHz)			
				20407/824.7	20525/836.5	20643/848.3	
1.4MHz	QPSK	1	0	23.36	23.34	23.38	24.00
		1	2	23.48	23.41	23.33	24.00
		1	5	23.53	23.60	23.59	24.00
		3	0	23.62	23.59	23.64	24.00
		3	2	23.53	23.67	23.55	24.00
		3	3	23.66	23.70	23.71	24.00
		6	0	22.66	22.71	22.64	23.00
	16QAM	1	0	22.64	22.51	22.36	23.00
		1	2	22.62	22.73	22.66	23.00
		1	5	22.64	22.74	22.71	23.00
		3	0	22.15	22.11	22.04	23.00
		3	2	22.16	22.17	22.23	23.00
		3	3	22.19	22.27	22.19	23.00
		6	0	21.20	21.22	21.36	22.00
	64QAM	1	0	22.15	22.11	22.21	23.00
		1	2	22.51	22.62	22.58	23.00
		1	5	22.59	22.73	22.23	23.00
		3	0	22.15	22.08	22.16	23.00
		3	2	22.13	22.16	22.15	23.00
		3	3	22.17	22.24	22.19	23.00
		6	0	21.19	21.21	21.29	22.00
Bandwidth	Modulation	RB size	RB offset	Channel/Frequency (MHz)			Tune-up Limit
				20415/825.5	20525/836.5	20635/847.5	



3MHz	QPSK	1	0	23.36	23.33	23.38	24.00
		1	7	23.45	23.44	23.35	24.00
		1	14	23.52	23.59	23.58	24.00
		8	0	22.70	22.67	22.74	23.00
		8	4	22.63	22.73	22.62	23.00
		8	7	22.73	22.80	22.78	23.00
		15	0	22.68	22.72	22.64	23.00
	16QAM	1	0	22.61	22.50	22.36	23.00
		1	7	22.63	22.72	22.68	23.00
		1	14	22.63	22.74	22.70	23.00
		8	0	21.24	21.23	21.14	22.00
		8	4	21.23	21.24	21.30	22.00
		8	7	21.27	21.35	21.29	22.00
		15	0	21.21	21.22	21.34	22.00
	64QAM	1	0	22.12	22.10	22.21	23.00
		1	7	22.52	22.61	22.58	23.00
		1	14	22.62	22.71	22.26	23.00
		8	0	21.26	21.24	21.30	22.00
		8	4	21.21	21.25	21.25	22.00
		8	7	21.25	21.32	21.29	22.00
		15	0	21.20	21.21	21.27	22.00
Bandwidth	Modulation	RB size	RB offset	Channel/Frequency (MHz)			Tune-up Limit
				20425/826.5	20525/836.5	20625/846.5	
5MHz	QPSK	1	0	23.37	23.37	23.40	24.00
		1	13	23.47	23.45	23.38	24.00
		1	24	23.55	23.64	23.62	24.00
		12	0	22.72	22.71	22.77	23.00
		12	6	22.66	22.78	22.66	23.00
		12	13	22.76	22.83	22.82	23.00
		25	0	22.70	22.76	22.69	23.00
	16QAM	1	0	22.66	22.52	22.38	23.00
		1	13	22.65	22.75	22.70	23.00
		1	24	22.66	22.78	22.73	23.00
		12	0	21.27	21.25	21.17	22.00
		12	6	21.26	21.29	21.34	22.00
		12	13	21.29	21.39	21.32	22.00
		25	0	21.24	21.27	21.38	22.00
	64QAM	1	0	22.17	22.12	22.23	23.00
		1	13	22.54	22.64	22.60	23.00
		1	24	22.61	22.72	22.25	23.00
		12	0	21.27	21.22	21.29	22.00
		12	6	21.23	21.28	21.26	22.00
		12	13	21.27	21.36	21.32	22.00



Bandwidth	Modulation	25	0	21.23	21.26	21.31	22.00
		RB size	RB offset	Channel/Frequency (MHz)			Tune-up Limit
				20450/829	20525/836.5	20600/844	
10MHz	QPSK	1	0	23.33	23.29	23.35	24.00
		1	25	23.44	23.40	23.33	24.00
		1	49	23.50	23.58	23.55	24.00
		25	0	22.67	22.62	22.70	23.00
		25	13	22.61	22.69	22.59	23.00
		25	25	22.70	22.75	22.74	23.00
		50	0	22.65	22.67	22.60	23.00
	16QAM	1	0	22.39	22.46	22.31	23.00
		1	25	22.59	22.70	22.64	23.00
		1	49	22.61	22.71	22.68	23.00
		25	0	21.21	21.19	21.11	22.00
		25	13	21.20	21.22	21.27	22.00
		25	25	21.24	21.30	21.25	22.00
		50	0	21.19	21.18	21.31	22.00
	64QAM	1	0	22.10	22.06	22.16	23.00
		1	25	22.48	22.59	22.54	23.00
		1	49	22.56	22.65	22.20	23.00
		25	0	21.21	21.16	21.23	22.00
		25	13	21.17	21.21	21.19	22.00
		25	25	21.22	21.27	21.25	22.00
		50	0	21.18	21.17	21.24	22.00

LTE FDD Band 13 Normal Power				Conducted Power(dBm)			Tune-up Limit
Bandwidth	Modulation	RB size	RB offset	Channel/Frequency (MHz)			
				23205/779.5	23230/782	23255/784.5	
5MHz	QPSK	1	0	23.26	23.29	23.25	24.00
		1	13	23.26	23.23	23.28	24.00
		1	24	23.52	23.47	23.51	24.00
		12	0	22.68	22.66	22.68	23.00
		12	6	22.73	22.72	22.75	23.00
		12	13	22.79	22.71	22.76	23.00
		25	0	22.67	22.70	22.72	23.00
	16QAM	1	0	22.86	22.69	22.76	23.00
		1	13	22.71	22.74	22.75	23.00
		1	24	22.06	22.06	22.05	23.00
		12	0	21.20	21.12	21.17	22.00
		12	6	21.76	21.70	21.73	22.00
		12	13	21.80	21.78	21.80	22.00
		25	0	21.29	21.28	21.31	22.00



Bandwidth	Modulation	RB size	RB offset	Channel/Frequency (MHz)			Tune-up Limit	
				/	23230/782	/		
10MHz	64QAM	1	0	22.22	22.14	22.17	23.00	
		1	13	22.17	22.11	22.14	23.00	
		1	24	22.18	22.11	22.13	23.00	
		12	0	21.53	21.37	21.50	22.00	
		12	6	21.42	21.34	21.39	22.00	
		12	13	21.40	21.38	21.40	22.00	
		25	0	21.31	21.30	21.33	22.00	
	10MHz	QPSK	1	0	/	23.33	/	24.00
			1	25	/	23.39	/	24.00
			1	49	/	23.58	/	24.00
			25	0	/	22.73	/	23.00
			25	13	/	22.74	/	23.00
			25	25	/	22.81	/	23.00
			50	0	/	22.75	/	23.00
		16QAM	1	0	/	22.79	/	23.00
			1	25	/	22.65	/	23.00
			1	49	/	22.14	/	23.00
			25	0	/	21.26	/	22.00
			25	13	/	21.79	/	22.00
			25	25	/	21.85	/	22.00
			50	0	/	21.36	/	22.00
64QAM		1	0	/	22.20	/	23.00	
		1	25	/	22.23	/	23.00	
		1	49	/	22.19	/	23.00	
		25	0	/	21.51	/	22.00	
		25	13	/	21.43	/	22.00	
		25	25	/	21.45	/	22.00	
		50	0	/	21.38	/	22.00	

LTE FDD Band 66 Normal Power				Conducted Power(dBm)			Tune-up Limit
Bandwidth	Modulation	RB size	RB offset	Channel/Frequency (MHz)			
				131979/1710.7	132322/1745	132665/1779.3	
1.4MHz	QPSK	1	0	23.28	23.25	23.29	24.00
		1	2	23.52	23.51	23.54	24.00
		1	5	23.42	23.51	23.49	24.00
		3	0	23.71	23.76	23.64	24.00
		3	2	23.72	23.79	23.74	24.00
		3	3	23.72	23.73	23.67	24.00
		6	0	22.65	22.80	22.75	23.00
	16QAM	1	0	22.71	22.73	22.70	23.00



		1	2	22.69	22.63	22.63	23.00
		1	5	22.73	22.78	22.79	23.00
		3	0	22.53	22.57	22.51	23.00
		3	2	22.54	22.48	22.53	23.00
		3	3	22.56	22.62	22.58	23.00
		6	0	21.56	21.61	21.64	22.00
	64QAM	1	0	22.73	22.81	22.76	23.00
		1	2	22.74	22.82	22.79	23.00
		1	5	22.79	22.91	22.71	23.00
		3	0	22.44	22.46	22.56	23.00
		3	2	22.56	22.58	22.64	23.00
		3	3	22.54	22.58	22.58	23.00
	6	0	21.66	21.59	21.71	22.00	
Bandwidth	Modulation	RB size	RB offset	Channel/Frequency (MHz)			Tune-up Limit
				1319871711.5	132322/1745	132657/1778.5	
3MHz	QPSK	1	0	23.30	23.29	23.32	24.00
		1	7	23.50	23.54	23.58	24.00
		1	14	23.45	23.56	23.53	24.00
		8	0	22.81	22.88	22.77	23.00
		8	4	22.84	22.89	22.86	23.00
		8	7	22.82	22.84	22.77	23.00
		15	0	22.65	22.84	22.78	23.00
	16QAM	1	0	22.74	22.75	22.73	23.00
		1	7	22.72	22.63	22.67	23.00
		1	14	22.75	22.82	22.82	23.00
		8	0	21.64	21.70	21.63	22.00
		8	4	21.65	21.61	21.65	22.00
		8	7	21.66	21.74	21.71	22.00
		15	0	21.59	21.65	21.67	22.00
	64QAM	1	0	22.76	22.83	22.79	23.00
		1	7	22.77	22.82	22.81	23.00
		1	14	22.81	22.90	22.74	23.00
		8	0	21.55	21.59	21.68	22.00
		8	4	21.67	21.71	21.76	22.00
		8	7	21.64	21.70	21.71	22.00
		15	0	21.69	21.63	21.74	22.00
Bandwidth	Modulation	RB size	RB offset	Channel/Frequency (MHz)			Tune-up Limit
				131997/1712.5	132322/1745	132647/1777.5	
5MHz	QPSK	1	0	23.29	23.28	23.31	24.00
		1	13	23.51	23.55	23.59	24.00
		1	24	23.44	23.55	23.52	24.00
		12	0	22.81	22.88	22.77	23.00
		12	6	22.85	22.90	22.85	23.00



		12	13	22.82	22.86	22.78	23.00
		25	0	22.69	22.85	22.80	23.00
	16QAM	1	0	22.73	22.74	22.72	23.00
		1	13	22.72	22.65	22.67	23.00
		1	24	22.75	22.82	22.81	23.00
		12	0	21.65	21.71	21.64	22.00
		12	6	21.64	21.60	21.64	22.00
		12	13	21.66	21.74	21.71	22.00
		25	0	21.60	21.66	21.66	22.00
	64QAM	1	0	22.75	22.82	22.78	23.00
		1	13	22.77	22.84	22.81	23.00
		1	24	22.81	22.90	22.73	23.00
		12	0	21.56	21.60	21.69	22.00
		12	6	21.66	21.70	21.75	22.00
12		13	21.64	21.70	21.71	22.00	
25		0	21.70	21.64	21.73	22.00	
Bandwidth	Modulation	RB size	RB offset	Channel/Frequency (MHz)			Tune-up Limit
				132022/1715	132322/1745	132622/1775	
10MHz	QPSK	1	0	23.27	23.27	23.28	24.00
		1	25	23.48	23.50	23.55	24.00
		1	49	23.42	23.51	23.49	24.00
		25	0	22.78	22.83	22.73	23.00
		25	13	22.82	22.85	22.81	23.00
		25	25	22.80	22.82	22.73	23.00
		50	0	22.65	22.83	22.76	23.00
	16QAM	1	0	22.71	22.71	22.70	23.00
		1	25	22.69	22.61	22.64	23.00
		1	49	22.72	22.80	22.78	23.00
		25	0	21.62	21.66	21.60	22.00
		25	13	21.62	21.56	21.61	22.00
		25	25	21.63	21.69	21.67	22.00
		50	0	21.57	21.61	21.62	22.00
	64QAM	1	0	22.73	22.83	22.76	23.00
		1	25	22.74	22.84	22.78	23.00
		1	49	22.82	22.88	22.70	23.00
		25	0	21.53	21.55	21.69	22.00
		25	13	21.64	21.66	21.72	22.00
		25	25	21.61	21.65	21.67	22.00
		50	0	21.67	21.59	21.69	22.00
Bandwidth	Modulation	RB size	RB offset	Channel/Frequency (MHz)			Tune-up Limit
				132047/1717.5	132322/1745	132597/1772.5	
15MHz	QPSK	1	0	23.28	23.24	23.29	24.00
		1	38	23.49	23.54	23.56	24.00



Bandwidth	Modulation	RB size	RB offset	Channel/Frequency (MHz)			Tune-up Limit	
				132072/1720	132322/1745	132572/1770		
20MHz	16QAM	1	74	23.41	23.50	23.48	24.00	
		36	0	22.79	22.84	22.74	23.00	
		36	18	22.82	22.85	22.81	23.00	
		36	39	22.79	22.83	22.74	23.00	
		75	0	22.67	22.81	22.75	23.00	
		1	0	22.68	22.72	22.70	23.00	
		1	38	22.70	22.62	22.65	23.00	
		1	74	22.72	22.78	22.78	23.00	
		36	0	21.62	21.69	21.61	22.00	
		36	18	21.61	21.55	21.60	22.00	
		36	39	21.64	21.70	21.68	22.00	
		75	0	21.57	21.61	21.62	22.00	
		1	0	22.70	22.80	22.76	23.00	
		1	38	22.75	22.81	22.79	23.00	
	1	74	22.82	22.89	22.74	23.00		
	36	0	21.55	21.62	21.70	22.00		
	36	18	21.64	21.67	21.74	22.00		
	36	39	21.62	21.66	21.68	22.00		
	75	0	21.67	21.59	21.69	22.00		
	20MHz	QPSK	1	0	23.25	23.20	23.26	24.00
			1	50	23.48	23.50	23.54	24.00
			1	99	23.39	23.49	23.45	24.00
			50	0	22.76	22.79	22.70	23.00
			50	25	22.80	22.81	22.78	23.00
			50	50	22.76	22.78	22.70	23.00
			100	0	22.64	22.76	22.71	23.00
		16QAM	1	0	22.61	22.68	22.65	23.00
			1	50	22.66	22.60	22.61	23.00
1			99	22.70	22.75	22.76	23.00	
50			0	21.59	21.65	21.58	22.00	
50			25	21.58	21.53	21.57	22.00	
50			50	21.61	21.65	21.64	22.00	
100			0	21.55	21.57	21.59	22.00	
64QAM		1	0	22.68	22.76	22.71	23.00	
		1	50	22.71	22.79	22.75	23.00	
		1	99	22.76	22.83	22.68	23.00	
		50	0	21.50	21.54	21.63	22.00	
		50	25	21.60	21.63	21.68	22.00	
		50	50	21.59	21.61	21.64	22.00	
		100	0	21.65	21.55	21.66	22.00	



LTE FDD Band 66 Level 6				Conducted Power(dBm)			Tune-up Limit
Bandwidth	Modulation	RB size	RB offset	Channel/Frequency (MHz)			
				131979/1710.7	132322/1745	132665/1779.3	
1.4MHz	QPSK	1	0	23.09	23.12	23.11	23.50
		1	2	23.07	22.94	23.07	23.50
		1	5	23.22	23.14	23.07	23.50
		3	0	23.16	23.02	23.18	23.50
		3	2	23.09	23.16	23.16	23.50
		3	3	23.10	23.09	23.19	23.50
		6	0	22.20	22.29	22.27	22.50
	16QAM	1	0	22.19	22.34	22.27	22.50
		1	2	22.17	22.20	22.13	22.50
		1	5	22.19	22.22	22.17	22.50
		3	0	22.26	22.28	22.23	22.50
		3	2	22.20	22.22	22.16	22.50
		3	3	22.25	22.31	22.21	22.50
		6	0	21.34	21.41	21.35	21.50
	64QAM	1	0	22.35	22.37	22.30	22.50
		1	2	22.02	22.05	22.00	22.50
		1	5	22.05	22.13	22.03	22.50
		3	0	22.25	22.23	22.18	22.50
		3	2	22.24	22.26	22.20	22.50
		3	3	22.25	22.31	22.21	22.50
		6	0	21.22	21.29	21.23	21.50
Bandwidth	Modulation	RB size	RB offset	Channel/Frequency (MHz)			Tune-up Limit
				131987/1711.5	132322/1745	132657/1778.5	
3MHz	QPSK	1	0	23.11	23.16	23.14	23.50
		1	7	23.05	22.97	23.11	23.50
		1	14	23.25	23.19	23.11	23.50
		8	0	22.26	22.14	22.31	22.50
		8	4	22.21	22.26	22.28	22.50
		8	7	22.20	22.20	22.29	22.50
		15	0	22.20	22.33	22.30	22.50
	16QAM	1	0	22.22	22.36	22.30	22.50
		1	7	22.20	22.20	22.17	22.50
		1	14	22.21	22.26	22.20	22.50
		8	0	21.37	21.41	21.35	21.50
		8	4	21.31	21.35	21.28	21.50
		8	7	21.35	21.43	21.34	21.50
		15	0	21.37	21.45	21.38	21.50
	64QAM	1	0	22.38	22.39	22.33	22.50
		1	7	22.05	22.05	22.02	22.50



Bandwidth	Modulation	RB size	RB offset	Channel/Frequency (MHz)			Tune-up Limit	
				131997/1712.5	132322/1745	132647/1777.5		
5MHz	QPSK	1	14	22.07	22.12	22.06	22.50	
		8	0	21.36	21.36	21.30	21.50	
		8	4	21.35	21.39	21.32	21.50	
		8	7	21.35	21.43	21.34	21.50	
		15	0	21.25	21.33	21.26	21.50	
		16QAM	1	0	23.09	23.11	23.11	23.50
			1	13	23.04	22.97	23.09	23.50
	1		24	23.21	23.13	23.06	23.50	
	12		0	22.24	22.10	22.28	22.50	
	12		6	22.19	22.22	22.23	22.50	
	12		13	22.17	22.19	22.26	22.50	
	25		0	22.22	22.30	22.27	22.50	
	64QAM	1	0	22.16	22.33	22.27	22.50	
		1	13	22.18	22.19	22.15	22.50	
		1	24	22.18	22.22	22.16	22.50	
		12	0	21.35	21.40	21.33	21.50	
		12	6	21.27	21.29	21.23	21.50	
		12	13	21.33	21.39	21.31	21.50	
		25	0	21.35	21.41	21.33	21.50	
	Bandwidth	Modulation	RB size	RB offset	Channel/Frequency (MHz)			Tune-up Limit
132022/1715					132322/1745	132622/1775		
10MHz	QPSK	1	0	23.08	23.14	23.10	23.50	
		1	25	23.03	22.93	23.08	23.50	
		1	49	23.22	23.14	23.07	23.50	
		25	0	22.23	22.09	22.27	22.50	
		25	13	22.19	22.22	22.23	22.50	
		25	25	22.18	22.18	22.25	22.50	
		50	0	22.20	22.32	22.28	22.50	
	16QAM	1	0	22.19	22.32	22.27	22.50	
		1	25	22.17	22.18	22.14	22.50	
		1	49	22.18	22.24	22.16	22.50	
		25	0	21.35	21.37	21.32	21.50	
		25	13	21.28	21.30	21.24	21.50	
		25	25	21.32	21.38	21.30	21.50	



Bandwidth	Modulation	RB size	RB offset	Channel/Frequency (MHz)			Tune-up Limit	
				132047/1717.5	132322/1745	132597/1772.5		
	64QAM	50	0	21.35	21.41	21.33	21.50	
		1	0	22.35	22.39	22.30	22.50	
		1	25	22.02	22.07	21.99	22.50	
		1	49	22.08	22.10	22.02	22.50	
		25	0	21.34	21.32	21.31	21.50	
		25	13	21.32	21.34	21.28	21.50	
		25	25	21.32	21.38	21.30	21.50	
		50	0	21.23	21.29	21.21	21.50	
15MHz	QPSK	1	0	23.10	23.15	23.13	23.50	
		1	38	23.06	22.98	23.12	23.50	
		1	74	23.24	23.18	23.10	23.50	
		36	0	22.26	22.14	22.31	22.50	
		36	18	22.22	22.27	22.27	22.50	
		36	39	22.20	22.22	22.30	22.50	
		75	0	22.24	22.34	22.32	22.50	
	16QAM	1	0	22.21	22.35	22.29	22.50	
		1	38	22.20	22.22	22.17	22.50	
		1	74	22.21	22.26	22.19	22.50	
		36	0	21.38	21.42	21.36	21.50	
		36	18	21.30	21.34	21.27	21.50	
		36	39	21.35	21.43	21.34	21.50	
		75	0	21.38	21.46	21.37	21.50	
	64QAM	1	0	22.37	22.38	22.32	22.50	
		1	38	22.05	22.07	22.02	22.50	
		1	74	22.07	22.12	22.05	22.50	
		36	0	21.37	21.37	21.31	21.50	
		36	18	21.34	21.38	21.31	21.50	
		36	39	21.35	21.43	21.34	21.50	
		75	0	21.26	21.34	21.25	21.50	
	Bandwidth	Modulation	RB size	RB offset	Channel/Frequency (MHz)			Tune-up Limit
					132072/1720	132322/1745	132572/1770	
	20MHz	QPSK	1	0	23.06	23.07	23.08	23.50
			1	50	23.03	22.93	23.07	23.50
			1	99	23.19	23.12	23.03	23.50
			50	0	22.21	22.05	22.24	22.50
			50	25	22.17	22.18	22.20	22.50
50			50	22.14	22.14	22.22	22.50	
100			0	22.19	22.25	22.23	22.50	
16QAM		1	0	22.27	22.29	22.22	22.50	
		1	50	22.14	22.17	22.11	22.50	
		1	99	22.16	22.19	22.14	22.50	



		50	0	21.32	21.36	21.30	21.50
		50	25	21.24	21.27	21.20	21.50
		50	50	21.30	21.34	21.27	21.50
		100	0	21.33	21.37	21.30	21.50
	64QAM	1	0	22.30	22.32	22.25	22.50
		1	50	21.99	22.02	21.96	22.50
		1	99	22.02	22.05	22.00	22.50
		50	0	21.31	21.31	21.25	21.50
		50	25	21.28	21.31	21.24	21.50
		50	50	21.30	21.34	21.27	21.50
		100	0	21.21	21.25	21.18	21.50



9.2.2 NR (EN-DC)

NR Band n2 Normal Power				Conducted Power(dBm)			Tune-up Limit
Bandwidth	Modulation	RB size	RB offset	Channel/Frequency (MHz)			
				370500/1852.5	376000/1880	381500/1907.5	
5MHz	DFT-s OFDM Pi/2 BPSK	1	1	23.66	23.84	23.85	25.00
		1	13	23.66	23.79	23.86	25.00
		1	23	23.64	23.76	23.84	25.00
		12	0	23.49	23.63	23.68	24.00
		12	7	23.52	23.67	23.72	24.00
		12	13	23.53	23.66	23.71	24.00
		25	0	23.43	23.60	23.64	24.00
	DFT-s OFDM QPSK	1	1	23.69	23.92	23.90	25.00
		1	13	23.67	23.78	23.86	25.00
		1	23	23.70	23.86	23.89	25.00
		12	0	23.75	23.84	23.87	24.00
		12	7	23.79	23.91	23.85	24.00
		12	13	23.74	23.89	23.87	24.00
		25	0	23.83	23.87	23.83	24.00
	DFT-s OFDM 16QAM	1	1	22.62	22.60	22.54	24.00
		1	13	22.88	22.79	22.80	24.00
		1	23	22.90	22.78	22.78	24.00
		12	0	22.24	22.44	22.59	23.00
		12	7	22.56	22.55	22.62	23.00
		12	13	22.66	22.57	22.59	23.00
		25	0	22.62	22.53	22.55	23.00
	DFT-s OFDM 64QAM	1	1	22.62	22.66	22.56	24.00
		1	13	22.25	22.14	22.18	24.00
		1	23	22.29	22.17	22.22	24.00
		12	0	22.05	22.11	22.09	23.00
		12	7	22.12	22.17	22.11	23.00
		12	13	22.20	22.19	22.13	23.00
		25	0	22.10	22.20	22.14	23.00
	DFT-s OFDM 256QAM	1	1	20.22	20.19	20.16	21.00
		1	13	20.20	20.14	20.16	21.00
1		23	20.06	20.05	20.10	21.00	
12		0	19.89	19.90	19.82	21.00	
12		7	19.94	19.95	19.92	21.00	
12		13	19.92	20.04	19.98	21.00	
25		0	19.89	19.97	20.01	21.00	
CP-OFDM QPSK	1	1	22.05	22.11	21.95	23.00	



Bandwidth	Modulation	RB size	RB offset	Channel/Frequency (MHz)			Tune-up Limit
				371000/1855	376000/1880	381000/1905	
10MHz	DFT-s OFDM Pi/2 BPSK	1	1	23.68	23.85	23.88	25.00
		1	26	23.69	23.84	23.90	25.00
		1	50	23.66	23.80	23.87	25.00
		25	0	23.52	23.68	23.72	24.00
		25	14	23.55	23.72	23.76	24.00
		25	27	23.55	23.70	23.76	24.00
		50	0	23.47	23.62	23.68	24.00
	DFT-s OFDM QPSK	1	1	23.71	23.95	23.92	25.00
		1	26	23.70	23.82	23.89	25.00
		1	50	23.73	23.88	23.92	25.00
		25	0	23.78	23.89	23.91	24.00
		25	14	23.81	23.95	23.88	24.00
		25	27	23.77	23.94	23.91	24.00
		50	0	23.86	23.92	23.87	24.00
	DFT-s OFDM 16QAM	1	1	22.64	22.59	22.56	24.00
		1	26	22.91	22.79	22.83	24.00
		1	50	22.89	22.80	22.81	24.00
		25	0	22.27	22.49	22.59	23.00
		25	14	22.58	22.59	22.65	23.00
		25	27	22.69	22.62	22.63	23.00
		50	0	22.65	22.58	22.59	23.00
	DFT-s OFDM 64QAM	1	1	22.64	22.67	22.59	24.00
		1	26	22.28	22.19	22.22	24.00
		1	50	22.31	22.21	22.25	24.00
		25	0	22.08	22.16	22.13	23.00
		25	14	22.15	22.22	22.15	23.00
		25	27	22.22	22.23	22.18	23.00
		50	0	22.14	22.22	22.18	23.00
	DFT-s OFDM 256QAM	1	1	20.24	20.22	20.18	21.00
		1	26	20.23	20.18	20.19	21.00
		1	50	20.09	20.07	20.13	21.00
		25	0	19.92	19.95	19.86	21.00
		25	14	19.96	19.99	19.95	21.00
		25	27	19.95	20.09	20.02	21.00
		50	0	19.92	20.02	20.05	21.00
	CP-OFDM QPSK	1	1	22.04	22.10	21.94	23.00
Bandwidth	Modulation	RB size	RB offset	Channel/Frequency (MHz)			Tune-up Limit
				371500/1857.5	376000/1880	380500/1902.5	
15MHz	DFT-s OFDM	1	1	23.67	23.81	23.86	25.00
	OFDM	1	40	23.67	23.83	23.87	25.00



	Pi/2 BPSK	1	77	23.63	23.75	23.83	25.00
		36	0	23.50	23.64	23.69	24.00
		36	22	23.52	23.67	23.72	24.00
		36	43	23.52	23.67	23.72	24.00
		75	0	23.45	23.58	23.63	24.00
	DFT-s OFDM QPSK	1	1	23.66	23.93	23.90	25.00
		1	40	23.68	23.79	23.87	25.00
		1	77	23.70	23.84	23.89	25.00
		36	0	23.75	23.87	23.88	24.00
		36	22	23.78	23.90	23.84	24.00
		36	43	23.75	23.90	23.88	24.00
		75	0	23.83	23.87	23.83	24.00
	DFT-s OFDM 16QAM	1	1	22.59	22.57	22.54	24.00
		1	40	22.89	22.76	22.81	24.00
		1	77	22.90	22.79	22.82	24.00
		36	0	22.26	22.51	22.60	23.00
		36	22	22.56	22.56	22.64	23.00
		36	43	22.67	22.58	22.60	23.00
		75	0	22.62	22.53	22.55	23.00
	DFT-s OFDM 64QAM	1	1	22.63	22.63	22.57	24.00
		1	40	22.26	22.18	22.19	24.00
		1	77	22.28	22.16	22.21	24.00
		36	0	22.06	22.12	22.10	23.00
		36	22	22.12	22.17	22.11	23.00
		36	43	22.19	22.20	22.14	23.00
		75	0	22.12	22.18	22.13	23.00
	DFT-s OFDM 256QAM	1	1	20.19	20.20	20.16	21.00
		1	40	20.21	20.15	20.17	21.00
		1	77	20.06	20.03	20.10	21.00
		36	0	19.89	19.93	19.83	21.00
		36	22	19.93	19.94	19.91	21.00
		36	43	19.93	20.05	19.99	21.00
		75	0	19.89	19.97	20.01	21.00
	CP-OFDM QPSK	1	1	22.03	22.06	21.92	23.00
	Bandwidth	Modulation	RB size	RB offset	Channel/Frequency (MHz)		
372000/1860					376000/1880	380000/1900	
20MHz	DFT-s OFDM Pi/2 BPSK	1	1	23.64	23.77	23.83	25.00
		1	53	23.66	23.79	23.85	25.00
		1	104	23.61	23.74	23.80	25.00
		50	0	23.47	23.59	23.65	24.00
		50	28	23.50	23.63	23.69	24.00
		50	56	23.49	23.62	23.68	24.00



		100	0	23.42	23.53	23.59	24.00
DFT-s OFDM QPSK		1	1	23.76	23.89	23.85	25.00
		1	53	23.64	23.77	23.83	25.00
		1	104	23.68	23.81	23.87	25.00
		50	0	23.72	23.83	23.85	24.00
		50	28	23.75	23.88	23.81	24.00
		50	56	23.72	23.85	23.84	24.00
		100	0	23.81	23.83	23.80	24.00
DFT-s OFDM 16QAM		1	1	22.57	22.53	22.49	24.00
		1	53	22.85	22.74	22.77	24.00
		1	104	22.84	22.73	22.76	24.00
		50	0	22.21	22.43	22.53	23.00
		50	28	22.52	22.52	22.58	23.00
		50	56	22.64	22.53	22.56	23.00
		100	0	22.60	22.49	22.52	23.00
DFT-s OFDM 64QAM		1	1	22.60	22.59	22.54	24.00
		1	53	22.25	22.14	22.17	24.00
		1	104	22.26	22.15	22.18	24.00
		50	0	22.03	22.07	22.06	23.00
		50	28	22.10	22.13	22.08	23.00
		50	56	22.16	22.15	22.10	23.00
		100	0	22.09	22.13	22.09	23.00
DFT-s OFDM 256QAM		1	1	20.11	20.16	20.11	21.00
		1	53	20.17	20.13	20.13	21.00
		1	104	20.04	20.00	20.08	21.00
		50	0	19.86	19.89	19.80	21.00
		50	28	19.90	19.92	19.88	21.00
		50	56	19.90	20.00	19.95	21.00
		100	0	19.87	19.93	19.98	21.00
CP-OFDM QPSK		1	1	22.00	22.02	21.89	23.00

NR Band n5 Normal Power				Conducted Power(dBm)			Tune-up Limit
Bandwidth	Modulation	RB size	RB offset	Channel/Frequency (MHz)			
				165300/826.5	167300/836.5	169300/846.5	
5MHz	DFT-s OFDM Pi/2 BPSK	1	1	23.51	23.70	23.60	25.00
		1	13	23.57	23.45	23.59	25.00
		1	23	23.62	23.57	23.52	25.00
		12	0	23.65	23.85	23.58	24.00
		12	7	23.54	23.81	23.63	24.00
		12	13	23.61	23.71	23.70	24.00
		25	0	23.51	23.72	23.60	24.00



	DFT-s OFDM QPSK	1	1	23.52	23.65	23.43	25.00
		1	13	23.42	23.54	23.41	25.00
		1	23	23.44	23.55	23.39	25.00
		12	0	23.81	23.91	23.78	24.00
		12	7	23.65	23.82	23.77	24.00
		12	13	23.61	23.72	23.61	24.00
		25	0	23.60	23.71	23.59	24.00
	DFT-s OFDM 16QAM	1	1	22.60	22.69	22.71	24.00
		1	13	22.61	22.55	22.73	24.00
		1	23	22.39	22.43	22.51	24.00
		12	0	22.43	22.42	22.38	23.00
		12	7	22.19	22.22	22.18	23.00
		12	13	22.12	22.26	22.26	23.00
		25	0	22.21	22.34	22.24	23.00
	DFT-s OFDM 64QAM	1	1	22.06	21.97	22.05	24.00
		1	13	22.04	21.77	21.89	24.00
		1	23	21.98	21.75	21.95	24.00
		12	0	22.20	22.31	22.03	23.00
		12	7	22.04	22.15	22.10	23.00
		12	13	21.92	22.17	22.00	23.00
		25	0	22.11	22.18	22.08	23.00
	DFT-s OFDM 256QAM	1	1	20.21	20.11	20.30	21.00
		1	13	20.17	20.01	20.26	21.00
		1	23	20.01	20.08	20.10	21.00
		12	0	20.25	20.21	20.28	21.00
		12	7	20.11	20.18	20.20	21.00
		12	13	20.23	20.32	20.32	21.00
		25	0	20.21	20.28	20.30	21.00
CP-OFDM QPSK	1	1	22.19	22.32	22.03	23.00	
Bandwidth	Modulation	RB size	RB offset	Channel/Frequency (MHz)			Tune-up Limit
				165800/829	167300/836.5	168800/844	
10MHz	DFT-s OFDM Pi/2 BPSK	1	1	23.67	23.56	23.51	25.00
		1	26	23.56	23.33	23.57	25.00
		1	50	23.54	23.45	23.62	25.00
		25	0	23.72	23.73	23.65	24.00
		25	14	23.78	23.69	23.54	24.00
		25	27	23.64	23.59	23.61	24.00
		50	0	23.68	23.60	23.51	24.00
	DFT-s OFDM QPSK	1	1	23.62	23.53	23.52	25.00
		1	26	23.63	23.42	23.42	25.00
		1	50	23.52	23.43	23.44	25.00
		25	0	23.71	23.79	23.39	24.00



		25	14	23.69	23.68	23.65	24.00	
		25	27	23.61	23.58	23.61	24.00	
		50	0	23.66	23.57	23.59	24.00	
	DFT-s OFDM 16QAM	1	1	22.62	22.70	22.74	24.00	
		1	26	22.64	22.60	22.77	24.00	
		1	50	22.41	22.47	22.54	24.00	
		25	0	22.46	22.47	22.42	23.00	
		25	14	22.22	22.27	22.22	23.00	
		25	27	22.14	22.30	22.31	23.00	
		50	0	22.25	22.36	22.28	23.00	
		DFT-s OFDM 64QAM	1	1	21.79	21.83	22.03	24.00
	1		26	21.67	21.63	22.01	24.00	
	1		50	21.64	21.61	21.95	24.00	
	25		0	22.37	22.37	22.37	23.00	
	25		14	22.27	22.21	22.21	23.00	
	25		27	22.26	22.23	22.11	23.00	
	50		0	22.34	22.24	22.31	23.00	
	DFT-s OFDM 256QAM	1	1	20.11	19.85	20.21	21.00	
		1	26	20.00	19.64	20.17	21.00	
		1	50	19.97	19.60	20.01	21.00	
		25	0	20.36	20.30	20.25	21.00	
		25	14	20.27	20.23	20.11	21.00	
		25	27	20.30	20.18	20.23	21.00	
		50	0	20.51	20.24	20.21	21.00	
	CP-OFDM QPSK	1	1	22.21	22.33	22.06	23.00	
	Bandwidth	Modulation	RB size	RB offset	Channel/Frequency (MHz)			Tune-up Limit
					166300/831.5	167300/836.5	168300/841.5	
	15MHz	DFT-s OFDM Pi/2 BPSK	1	1	23.69	23.87	23.82	25.00
1			40	23.75	23.73	23.77	25.00	
1			77	23.80	23.65	23.80	25.00	
36			0	23.83	23.83	23.96	24.00	
36			22	23.72	23.84	23.93	24.00	
36			43	23.79	23.76	23.89	24.00	
75			0	23.69	23.85	23.85	24.00	
DFT-s OFDM QPSK		1	1	23.70	23.82	23.91	25.00	
		1	40	23.60	23.78	23.76	25.00	
		1	77	23.62	23.67	23.67	25.00	
		36	0	23.57	23.86	23.88	24.00	
		36	22	23.83	23.84	23.85	24.00	
		36	43	23.79	23.76	22.98	24.00	
		75	0	23.78	23.81	23.79	24.00	
DFT-s		1	1	22.61	22.66	22.72	24.00	



	OFDM 16QAM	1	40	22.62	22.59	22.74	24.00
		1	77	22.38	22.42	22.50	24.00
		36	0	22.44	22.43	22.39	23.00
		36	22	22.19	22.22	22.18	23.00
		36	43	22.11	22.27	22.27	23.00
		75	0	22.23	22.32	22.23	23.00
	DFT-s OFDM 64QAM	1	1	22.22	21.94	22.08	24.00
		1	40	21.99	21.82	22.07	24.00
		1	77	22.14	21.79	22.19	24.00
		36	0	22.56	22.52	22.59	23.00
		36	22	22.40	22.42	22.55	23.00
		36	43	22.30	22.41	22.44	23.00
	DFT-s OFDM 256QAM	75	0	22.49	22.49	22.58	23.00
		1	1	20.39	20.26	20.53	21.00
		1	40	20.35	20.15	20.40	21.00
		1	77	20.19	20.12	20.30	21.00
		36	0	20.43	20.51	20.58	21.00
		36	22	20.29	20.42	20.46	21.00
	CP-OFDM QPSK	36	43	20.41	20.45	20.42	21.00
		75	0	20.39	20.51	20.49	21.00
		1	1	22.20	22.29	22.04	23.00
Bandwidth	Modulation	RB size	RB offset	Channel/Frequency (MHz)			Tune-up Limit
				166800/834	167300/836.5	167800/839	
20MHz	DFT-s OFDM Pi/2 BPSK	1	1	23.65	23.74	23.76	25.00
		1	53	23.71	23.69	23.75	25.00
		1	104	23.76	23.72	23.68	25.00
		50	0	23.79	23.88	23.74	24.00
		50	28	23.68	23.85	23.79	24.00
		50	56	23.75	23.81	23.86	24.00
		100	0	23.65	23.77	23.76	24.00
	DFT-s OFDM QPSK	1	1	23.85	23.83	23.59	25.00
		1	53	23.56	23.68	23.52	25.00
		1	104	23.58	23.59	23.50	25.00
		50	0	23.53	23.80	23.47	24.00
		50	28	23.83	23.77	23.70	24.00
		50	56	23.75	22.90	23.72	24.00
		100	0	23.73	23.71	23.70	24.00
	DFT-s OFDM 16QAM	1	1	22.58	22.62	22.69	24.00
		1	53	22.61	22.55	22.72	24.00
		1	104	22.36	22.41	22.47	24.00
		50	0	22.41	22.38	22.35	23.00
		50	28	22.17	22.18	22.15	23.00



		50	56	22.08	22.22	22.23	23.00
		100	0	22.20	22.27	22.19	23.00
	DFT-s OFDM 64QAM	1	1	22.05	22.11	22.09	24.00
		1	53	22.03	22.06	21.93	24.00
		1	104	21.97	21.95	21.99	24.00
		50	0	22.51	22.47	22.39	23.00
		50	28	22.35	22.43	22.46	23.00
		50	56	22.25	22.32	22.36	23.00
		100	0	22.45	22.46	22.44	23.00
	DFT-s OFDM 256QAM	1	1	20.35	20.41	20.46	21.00
		1	53	20.31	20.28	20.42	21.00
		1	104	20.15	20.20	20.26	21.00
		50	0	20.39	20.48	20.44	21.00
		50	28	20.25	20.36	20.36	21.00
		50	56	20.37	20.32	20.48	21.00
		100	0	20.35	20.39	20.46	21.00
	CP-OFDM QPSK	1	1	22.17	22.25	22.01	23.00

NR Band n5 Level 1				Conducted Power(dBm)			Tune-up Limit
Bandwidth	Modulation	RB size	RB offset	Channel/Frequency (MHz)			
				165300/826.5	167300/836.5	169300/846.5	
5MHz	DFT-s OFDM Pi/2 BPSK	1	1	23.12	23.27	23.31	24.50
		1	13	23.14	23.15	23.28	24.50
		1	23	23.23	23.17	23.25	24.50
		12	0	23.18	23.23	23.15	23.50
		12	7	23.06	23.19	23.19	23.50
		12	13	23.16	23.16	23.27	23.50
		25	0	23.03	23.15	23.19	23.50
	DFT-s OFDM QPSK	1	1	22.99	23.22	23.03	24.50
		1	13	22.97	22.97	22.93	24.50
		1	23	22.96	22.93	22.88	24.50
		12	0	23.23	23.11	22.86	23.50
		12	7	23.17	23.08	23.11	23.50
		12	13	23.14	22.25	23.14	23.50
		25	0	23.05	23.05	23.10	23.50
	DFT-s OFDM 16QAM	1	1	21.99	21.99	22.13	23.50
		1	13	22.02	21.88	22.13	23.50
		1	23	21.90	21.86	21.97	23.50
		12	0	21.91	21.81	21.90	22.50
		12	7	21.67	21.59	21.67	22.50
		12	13	21.55	21.65	21.72	22.50



	DFT-s OFDM 64QAM	25	0	21.66	21.69	21.67	22.50
		1	1	21.57	21.60	21.61	23.50
		1	13	21.53	21.56	21.52	23.50
		1	23	21.52	21.53	21.61	23.50
		12	0	21.95	21.93	21.92	22.50
		12	7	21.79	21.89	21.99	22.50
		12	13	21.63	21.70	21.81	22.50
	DFT-s OFDM 256QAM	25	0	21.80	21.87	21.91	22.50
		1	1	19.70	19.70	19.85	20.50
		1	13	19.68	19.55	19.79	20.50
		1	23	19.51	19.51	19.62	20.50
		12	0	19.76	19.83	19.88	20.50
		12	7	19.63	19.73	19.82	20.50
		12	13	19.81	19.78	20.01	20.50
CP-OFDM QPSK	25	0	19.87	19.93	19.99	20.50	
1	1	21.72	21.82	21.56	22.50		
Bandwidth	Modulation	RB size	RB offset	Channel/Frequency (MHz)			Tune-up Limit
				165800/829	167300/836.5	168800/844	
10MHz	DFT-s OFDM Pi/2 BPSK	1	1	23.14	23.28	23.34	24.50
		1	26	23.17	23.20	23.32	24.50
		1	50	23.25	23.21	23.28	24.50
		25	0	23.21	23.28	23.19	23.50
		25	14	23.09	23.24	23.23	23.50
		25	27	23.18	23.20	23.32	23.50
		50	0	23.07	23.17	23.23	23.50
	DFT-s OFDM QPSK	1	1	23.01	23.25	23.05	24.50
		1	26	23.00	23.01	22.96	24.50
		1	50	22.99	22.95	22.91	24.50
		25	0	23.26	23.16	22.90	23.50
		25	14	23.19	23.12	23.14	23.50
		25	27	23.17	22.30	23.18	23.50
		50	0	23.08	23.10	23.14	23.50
	DFT-s OFDM 16QAM	1	1	22.01	21.98	22.15	23.50
		1	26	22.05	21.88	22.16	23.50
		1	50	21.89	21.88	22.00	23.50
		25	0	21.94	21.86	21.90	22.50
		25	14	21.69	21.63	21.70	22.50
		25	27	21.58	21.70	21.76	22.50
		50	0	21.69	21.74	21.71	22.50
	DFT-s OFDM 64QAM	1	1	21.59	21.61	21.64	23.50
		1	26	21.56	21.61	21.56	23.50
		1	50	21.54	21.47	21.64	23.50



		25	0	21.98	21.98	21.96	22.50
		25	14	21.82	21.94	22.03	22.50
		25	27	21.65	21.74	21.86	22.50
		50	0	21.84	21.89	21.95	22.50
	DFT-s OFDM 256QAM	1	1	19.72	19.73	19.87	20.50
		1	26	19.71	19.59	19.82	20.50
		1	50	19.54	19.53	19.65	20.50
		25	0	19.79	19.88	19.92	20.50
		25	14	19.65	19.77	19.85	20.50
		25	27	19.84	19.83	20.05	20.50
CP-OFDM QPSK	50	0	19.90	19.98	20.03	20.50	
	1	1	21.74	21.81	21.58	22.50	
Bandwidth	Modulation	RB size	RB offset	Channel/Frequency (MHz)			Tune-up Limit
				166300/831.5	167300/836.5	168300/841.5	
15MHz	DFT-s OFDM Pi/2 BPSK	1	1	23.13	23.24	23.32	24.50
		1	40	23.15	23.19	23.29	24.50
		1	77	23.22	23.16	23.24	24.50
		36	0	23.19	23.24	23.16	23.50
		36	22	23.06	23.19	23.19	23.50
		36	43	23.15	23.17	23.28	23.50
		75	0	23.05	23.13	23.18	23.50
	DFT-s OFDM QPSK	1	1	22.96	23.23	23.03	24.50
		1	40	22.98	22.98	22.94	24.50
		1	77	22.96	22.91	22.88	24.50
		36	0	23.23	23.14	22.87	23.50
		36	22	23.16	23.07	23.10	23.50
		36	43	23.15	22.26	23.15	23.50
		75	0	23.05	23.05	23.10	23.50
	DFT-s OFDM 16QAM	1	1	21.96	21.96	22.13	23.50
		1	40	22.03	21.85	22.14	23.50
		1	77	21.90	21.87	22.01	23.50
		36	0	21.93	21.88	21.91	22.50
		36	22	21.67	21.60	21.69	22.50
		36	43	21.56	21.66	21.73	22.50
		75	0	21.66	21.69	21.67	22.50
	DFT-s OFDM 64QAM	1	1	21.58	21.57	21.62	23.50
		1	40	21.54	21.60	21.53	23.50
		1	77	21.51	21.42	21.60	23.50
		36	0	21.96	21.94	21.93	22.50
		36	22	21.79	21.89	21.99	22.50
		36	43	21.62	21.71	21.82	22.50
		75	0	21.82	21.85	21.90	22.50



	DFT-s OFDM 256QAM	1	1	19.67	19.71	19.85	20.50
		1	40	19.69	19.56	19.80	20.50
		1	77	19.51	19.49	19.62	20.50
		36	0	19.76	19.86	19.89	20.50
		36	22	19.62	19.72	19.81	20.50
		36	43	19.82	19.79	20.02	20.50
		75	0	19.87	19.93	19.99	20.50
	CP-OFDM QPSK	1	1	21.69	21.79	21.56	22.50
Bandwidth	Modulation	RB size	RB offset	Channel/Frequency (MHz)			Tune-up Limit
				166800/834	167300/836.5	167800/839	
20MHz	DFT-s OFDM Pi/2 BPSK	1	1	23.10	23.20	23.29	24.50
		1	53	23.14	23.15	23.27	24.50
		1	104	23.20	23.15	23.21	24.50
		50	0	23.16	23.19	23.12	23.50
		50	28	23.04	23.15	23.16	23.50
		50	56	23.12	23.12	23.24	23.50
		100	0	23.02	23.08	23.14	23.50
	DFT-s OFDM QPSK	1	1	22.96	23.19	22.98	24.50
		1	53	22.94	22.96	22.90	24.50
		1	104	22.94	22.88	22.86	24.50
		50	0	23.20	23.10	22.84	23.50
		50	28	23.13	23.05	23.07	23.50
		50	56	23.12	22.21	23.11	23.50
		100	0	23.03	23.01	23.07	23.50
	DFT-s OFDM 16QAM	1	1	21.94	21.92	22.08	23.50
		1	53	21.99	21.83	22.10	23.50
		1	104	21.84	21.81	21.95	23.50
		50	0	21.88	21.80	21.84	22.50
		50	28	21.63	21.56	21.63	22.50
		50	56	21.53	21.61	21.69	22.50
		100	0	21.64	21.65	21.64	22.50
	DFT-s OFDM 64QAM	1	1	21.55	21.53	21.59	23.50
		1	53	21.53	21.56	21.51	23.50
		1	104	21.49	21.41	21.57	23.50
		50	0	21.93	21.89	21.89	22.50
		50	28	21.77	21.85	21.96	22.50
		50	56	21.59	21.66	21.78	22.50
		100	0	21.79	21.80	21.86	22.50
	DFT-s OFDM 256QAM	1	1	19.69	19.67	19.80	20.50
		1	53	19.65	19.54	19.76	20.50
		1	104	19.49	19.46	19.60	20.50
		50	0	19.73	19.82	19.86	20.50



		50	28	19.59	19.70	19.78	20.50
		50	56	19.79	19.74	19.98	20.50
		100	0	19.85	19.89	19.96	20.50
	CP-OFDM QPSK	1	1	21.67	21.75	21.51	22.50

NR Band n66 Normal Power				Conducted Power(dBm)			Tune-up Limit
Bandwidth	Modulation	RB size	RB offset	Channel/Frequency (MHz)			
				342500/1712.5	349000/1745	355500/1777.5	
5MHz	DFT-s OFDM Pi/2 BPSK	1	1	23.69	23.68	23.64	25.00
		1	13	23.63	23.58	23.57	25.00
		1	23	23.65	23.64	23.67	25.00
		12	0	23.75	23.67	23.78	24.00
		12	7	23.79	23.70	23.77	24.00
		12	13	23.74	23.78	23.76	24.00
		25	0	23.76	23.75	23.75	24.00
	DFT-s OFDM QPSK	1	1	23.68	23.67	23.77	25.00
		1	13	23.60	23.64	23.60	25.00
		1	23	23.67	23.62	23.79	25.00
		12	0	23.81	23.74	23.86	24.00
		12	7	23.79	23.74	23.79	24.00
		12	13	23.84	23.76	23.82	24.00
		25	0	23.78	23.75	23.77	24.00
	DFT-s OFDM 16QAM	1	1	22.52	22.45	22.58	24.00
		1	13	22.40	22.29	22.45	24.00
		1	23	22.59	22.53	22.47	24.00
		12	0	22.63	22.54	22.58	23.00
		12	7	22.34	22.38	22.34	23.00
		12	13	22.38	22.23	22.36	23.00
		25	0	22.39	22.34	22.28	23.00
	DFT-s OFDM 64QAM	1	1	22.04	22.08	22.13	24.00
		1	13	22.03	21.95	22.04	24.00
		1	23	22.08	22.09	22.12	24.00
		12	0	22.36	22.32	22.28	23.00
		12	7	22.28	22.30	22.32	23.00
		12	13	22.22	22.37	22.27	23.00
		25	0	22.37	22.38	22.37	23.00
	DFT-s OFDM 256QAM	1	1	19.86	19.86	19.88	21.00
		1	13	19.65	19.51	19.58	21.00
1		23	19.88	20.06	19.80	21.00	
12		0	19.86	19.81	19.86	21.00	
12		7	19.78	19.85	19.78	21.00	



Bandwidth	Modulation	RB size	RB offset	Channel/Frequency (MHz)			Tune-up Limit
				343000/1715	349000/1745	355500/1775	
10MHz	CP-OFDM QPSK	12	13	19.80	19.83	19.82	21.00
		25	0	19.86	19.94	19.90	21.00
		1	1	22.07	22.23	22.21	23.00
	DFT-s OFDM Pi/2 BPSK	1	1	23.71	23.60	23.75	25.00
		1	26	23.64	23.52	23.68	25.00
		1	50	23.74	23.59	23.78	25.00
		25	0	23.85	23.71	23.89	24.00
		25	14	23.84	23.71	23.88	24.00
		25	27	23.83	23.69	23.87	24.00
		50	0	23.82	23.68	23.86	24.00
	DFT-s OFDM QPSK	1	1	23.84	23.62	23.88	25.00
		1	26	23.67	23.49	23.71	25.00
		1	50	23.84	23.68	23.80	25.00
		25	0	23.91	23.80	23.87	24.00
		25	14	23.84	23.65	23.80	24.00
		25	27	23.87	23.71	23.83	24.00
		50	0	23.82	23.76	23.78	24.00
	DFT-s OFDM 16QAM	1	1	22.50	22.44	22.55	24.00
		1	26	22.37	22.24	22.41	24.00
		1	50	22.57	22.49	22.44	24.00
		25	0	22.60	22.49	22.54	23.00
		25	14	22.31	22.33	22.30	23.00
		25	27	22.36	22.19	22.31	23.00
		50	0	22.35	22.32	22.24	23.00
	DFT-s OFDM 64QAM	1	1	22.02	22.05	22.11	24.00
		1	26	22.00	21.91	22.01	24.00
		1	50	22.05	22.07	22.09	24.00
		25	0	22.33	22.27	22.24	23.00
		25	14	22.26	22.26	22.29	23.00
		25	27	22.19	22.32	22.23	23.00
50		0	22.34	22.33	22.33	23.00	
DFT-s OFDM 256QAM	1	1	19.84	19.87	19.86	21.00	
	1	26	19.62	19.51	19.55	21.00	
	1	50	19.89	20.04	19.77	21.00	
	25	0	19.83	19.76	19.86	21.00	
	25	14	19.76	19.81	19.75	21.00	
	25	27	19.77	19.78	19.78	21.00	
	50	0	19.83	19.89	19.86	21.00	
CP-OFDM QPSK	1	1	22.09	22.24	22.24	23.00	



Bandwidth	Modulation	RB size	RB offset	Channel/Frequency (MHz)			Tune-up Limit
				343500/1717.5	349000/1745	354500/1772.5	
15MHz	DFT-s OFDM Pi/2 BPSK	1	1	23.75	23.66	23.71	25.00
		1	40	23.69	23.58	23.64	25.00
		1	77	23.71	23.64	23.74	25.00
		36	0	23.81	23.76	23.85	24.00
		36	22	23.85	23.76	23.84	24.00
		36	43	23.80	23.74	23.83	24.00
		75	0	23.82	23.73	23.82	24.00
	DFT-s OFDM QPSK	1	1	23.74	23.67	23.83	25.00
		1	40	23.66	23.54	23.66	25.00
		1	77	23.73	23.73	23.85	25.00
		36	0	23.87	23.85	23.92	24.00
		36	22	23.85	23.70	23.85	24.00
		36	43	23.90	23.76	23.88	24.00
		75	0	23.84	23.81	23.83	24.00
	DFT-s OFDM 16QAM	1	1	22.51	22.41	22.56	24.00
		1	40	22.38	22.28	22.42	24.00
		1	77	22.56	22.48	22.43	24.00
		36	0	22.61	22.50	22.55	23.00
		36	22	22.31	22.33	22.30	23.00
		36	43	22.35	22.20	22.32	23.00
		75	0	22.37	22.30	22.23	23.00
	DFT-s OFDM 64QAM	1	1	21.99	22.06	22.11	24.00
		1	40	22.01	21.92	22.02	24.00
		1	77	22.05	22.05	22.09	24.00
		36	0	22.33	22.30	22.25	23.00
		36	22	22.25	22.25	22.28	23.00
		36	43	22.20	22.33	22.24	23.00
		75	0	22.34	22.33	22.33	23.00
	DFT-s OFDM 256QAM	1	1	19.81	19.84	19.86	21.00
		1	40	19.63	19.48	19.56	21.00
1		77	19.89	20.05	19.81	21.00	
36		0	19.85	19.83	19.87	21.00	
36		22	19.76	19.82	19.77	21.00	
36		43	19.78	19.79	19.79	21.00	
75		0	19.83	19.89	19.86	21.00	
CP-OFDM QPSK	1	1	22.08	22.20	22.22	23.00	
Bandwidth	Modulation	RB size	RB offset	Channel/Frequency (MHz)			Tune-up Limit
				344000/1720	349000/1745	354000/1770	
20MHz	DFT-s OFDM	1	1	23.71	23.52	23.73	25.00
	OFDM	1	53	23.58	23.49	23.62	25.00



	Pi/2 BPSK	1	104	23.74	23.60	23.71	25.00
		50	0	23.70	23.71	23.76	24.00
		50	28	23.79	23.69	23.85	24.00
		50	56	23.75	23.72	23.83	24.00
		100	0	23.80	23.71	23.80	24.00
	DFT-s OFDM QPSK	1	1	23.74	23.68	23.87	25.00
		1	53	23.67	23.49	23.71	25.00
		1	104	23.81	23.68	23.80	25.00
		50	0	23.77	23.69	23.82	24.00
		50	28	23.84	23.66	23.85	24.00
		50	56	23.78	23.64	23.82	24.00
		100	0	23.78	23.67	23.82	24.00
	DFT-s OFDM 16QAM	1	1	22.48	22.37	22.53	24.00
		1	53	22.37	22.24	22.40	24.00
		1	104	22.54	22.47	22.40	24.00
		50	0	22.58	22.45	22.51	23.00
		50	28	22.29	22.29	22.27	23.00
		50	56	22.32	22.15	22.28	23.00
		100	0	22.34	22.25	22.19	23.00
	DFT-s OFDM 64QAM	1	1	22.01	22.02	22.06	24.00
		1	53	21.97	21.90	21.98	24.00
		1	104	22.03	22.02	22.07	24.00
		50	0	22.30	22.26	22.22	23.00
		50	28	22.22	22.23	22.25	23.00
		50	56	22.17	22.28	22.20	23.00
		100	0	22.32	22.29	22.30	23.00
	DFT-s OFDM 256QAM	1	1	19.79	19.80	19.81	21.00
		1	53	19.59	19.46	19.52	21.00
		1	104	19.83	19.99	19.75	21.00
		50	0	19.80	19.75	19.80	21.00
		50	28	19.72	19.78	19.71	21.00
		50	56	19.75	19.74	19.75	21.00
100		0	19.81	19.85	19.83	21.00	
CP-OFDM QPSK	1	1	22.05	22.16	22.19	23.00	



9.3 WLAN Mode

Wi-Fi 2.4G Normal Power Mode	Channel /Frequency(MHz)	Maximum Output Power (dBm)		
		Tune-up	Meas.	TP Set Level
802.11b (1M)	1/2412	22.00	20.86	20
	6/2437	22.00	20.91	20
	11/2462	22.00	20.75	20
802.11g (6M)	1/2412	21.00	18.52	19
	6/2437	21.00	19.11	19
	11/2462	21.00	18.72	19
802.11n-HT20 (MCS0)	1/2412	21.00	18.33	19
	6/2437	21.00	18.94	19
	11/2462	21.00	18.55	19
802.11n-HT40 (MCS0)	3/2422	20.50	18.26	18.5
	6/2437	20.50	18.52	18.5
	9/2452	20.50	18.22	18.5

Note: Initial test configuration is 802.11b mode.

Wi-Fi 2.4G Level 1&2&3 Mode	Channel /Frequency(MHz)	Maximum Output Power (dBm)		
		Tune-up	Meas.	TP Set Level
802.11b (1M)	1/2412	19.00	18.16	17
	6/2437	19.00	18.33	17
	11/2462	19.00	18.22	17
802.11g (6M)	1/2412	18.00	15.70	16
	6/2437	18.00	16.13	16
	11/2462	18.00	16.23	16
802.11n-HT20 (MCS0)	1/2412	18.00	15.56	16
	6/2437	18.00	15.97	16
	11/2462	18.00	16.06	16
802.11n-HT40 (MCS0)	3/2422	17.50	15.09	15.5
	6/2437	17.50	16.15	15.5
	9/2452	17.50	15.11	15.5

Note: Initial test configuration is 802.11b mode.



Wi-Fi 5G (U-NII-1) Normal Power Mode	Channel /Frequency(MHz)	Maximum Output Power (dBm)		
		Tune-up	Meas.	TP Set Level
802.11a (6M)	36/5180	22.00	21.50	20
	40/5200	22.00	21.36	20
	44/5220	22.00	21.32	20
	48/5240	22.00	21.09	20
802.11n-HT20 (MCS0)	36/5180	21.50	20.87	19.5
	40/5200	21.50	20.77	19.5
	44/5220	21.50	20.59	19.5
	48/5240	21.50	20.52	19.5
802.11n-HT40 (MCS0)	38/5190	21.00	20.78	19
	46/5230	21.00	20.55	19
802.11ac-VHT20 (MCS0)	36/5180	21.00	20.37	19
	40/5200	21.00	20.50	19
	44/5220	21.00	20.34	19
	48/5240	21.00	20.16	19
802.11ac-VHT40 (MCS0)	38/5190	20.00	19.78	18
	46/5230	20.00	19.72	18
802.11ac-VHT80 (MCS0)	42/5210	20.00	19.62	18

Note. Initial test configuration is 802.11a mode, since the highest maximum output power.

Wi-Fi 5G (U-NII-1) Level 1&2&3 Mode	Channel /Frequency(MHz)	Maximum Output Power (dBm)		
		Tune-up	Meas.	TP Set Level
802.11a (6M)	36/5180	19.00	17.88	17
	40/5200	19.00	17.76	17
	44/5220	19.00	17.74	17
	48/5240	19.00	17.66	17
802.11n-HT20 (MCS0)	36/5180	18.00	16.48	16.5
	40/5200	18.00	16.63	16.5
	44/5220	18.00	16.54	16.5
	48/5240	18.00	16.53	16.5
802.11n-HT40 (MCS0)	38/5190	18.00	15.89	16
	46/5230	18.00	16.10	16
802.11ac-VHT20 (MCS0)	36/5180	18.00	15.92	16
	40/5200	18.00	16.15	16
	44/5220	18.00	16.02	16



	48/5240	18.00	15.94	16
802.11ac-VHT40 (MCS0)	38/5190	17.00	15.24	15
	46/5230	17.00	15.32	15
802.11ac-VHT80 (MCS0)	42/5210	17.00	14.87	15

Note. Initial test configuration is 802.11a mode, since the highest maximum output power.

Wi-Fi 5G (U-NII-3) Normal Power Mode	Channel /Frequency(MHz)	Maximum Output Power (dBm)		
		Tune-up	Meas.	TP Set Level
802.11a (6M)	149/5745	22.00	21.07	20
	157/5785	22.00	21.31	20
	165/5825	22.00	21.38	20
802.11n-HT20 (MCS0)	149/5745	21.50	20.47	19.5
	157/5785	21.50	20.58	19.5
	165/5825	21.50	20.72	19.5
802.11n-HT40 (MCS0)	151/5755	21.00	20.41	19
	159/5795	21.00	20.63	19
802.11ac-HT20 (MCS0)	149/5745	21.00	20.22	19
	157/5785	21.00	20.15	19
	165/5825	21.00	20.44	19
802.11ac-HT40 (MCS0)	151/5755	20.00	19.50	18
	159/5795	20.00	19.76	18
802.11ac-HT80 (MCS0)	155/5775	20.00	19.39	18

Note. Initial test configuration is 802.11a mode, since the highest maximum output power.

Wi-Fi 5G (U-NII-3) Level 1&2&3 Mode	Channel /Frequency(MHz)	Maximum Output Power (dBm)		
		Tune-up	Meas.	TP Set Level
802.11a (6M)	149/5745	19.00	17.89	17
	157/5785	19.00	17.86	17
	165/5825	19.00	17.83	17
802.11n-HT20 (MCS0)	149/5745	18.00	17.20	16.5
	157/5785	18.00	17.31	16.5
	165/5825	18.00	17.05	16.5
802.11n-HT40 (MCS0)	151/5755	18.00	16.67	16
	159/5795	18.00	16.75	16
802.11ac-HT20 (MCS0)	149/5745	18.00	16.68	16
	157/5785	18.00	16.76	16



	165/5825	18.00	16.49	16
802.11ac-HT40 (MCS0)	151/5755	17.00	16.03	15
	159/5795	17.00	16.12	15
802.11ac-HT80 (MCS0)	155/5775	17.00	15.69	15

Note. Initial test configuration is 802.11a mode, since the highest maximum output power.

9.4 Bluetooth Mode

BT	Maximum Output Power (dBm)		Tune-up Limit (dBm)	Maximum Output Power (dBm)	Tune-up Limit (dBm)
	Channel/Frequency(MHz)			Channel/Frequency(MHz)	
	Ch 0/2402	Ch 39/2441		Ch 78/2480	
GFSK	12.53	12.63	13.50	13.23	14.50
$\pi/4$ DQPSK	11.40	11.48	12.00	12.40	13.00
8DPSK	11.51	11.57	12.00	12.25	13.00
BLE	Ch 0/2402	Ch 19/2440	Tune-up Limit (dBm)	Ch 39/2480	Tune-up Limit (dBm)
GFSK (1M)	4.88	5.06	9.00	7.12	10.00
GFSK (2M)	2.02	2.27	9.00	3.87	10.00

10 Measured and Reported (Scaled) SAR Results

10.1 EUT Antenna Locations

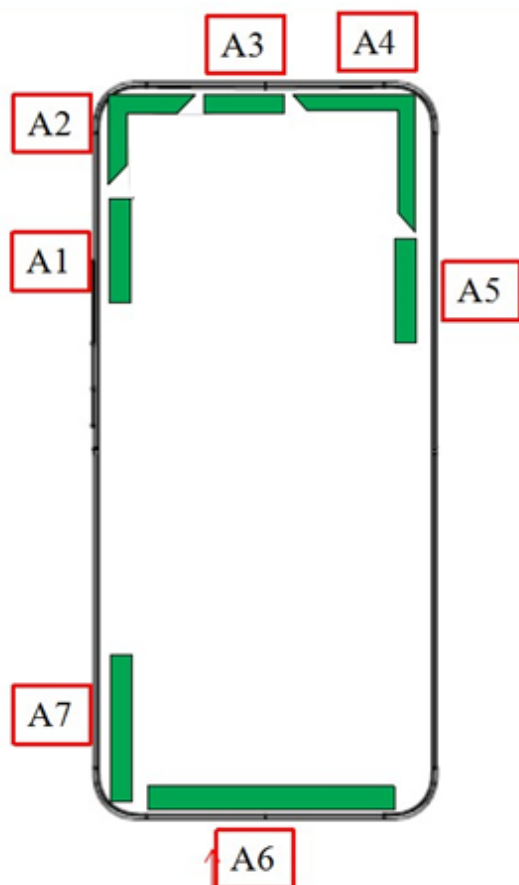

- (A1):WiFi 2.4G/ WiFi 5G CH0
- (A2):GPS
- (A3):LTE B2/4/66 Drx+n2/66 Drx mimo
- (A4):LTE B5/12/13 Trx+n5 Trx
- (A5):LTE B2/4/66 Drx MIMO+ N2/66 Drx
- (A6):LTE B5/12/13 Drx+ LTE B2/4/66 TRx + n2/66 Prx mimo+n5 Drx
- (A7): LTE B2/4/66 Prx mimo+n2/66 Trx +LTE B2/66 Trx(N5 ENDC)

the separation distance for antenna to edge:

Antenna	to top side (mm)	to bottom side (mm)	to left side (mm)	to right side (mm)
A1	18	130	0.8	69
A2	0.8	151	0.8	56
A3	0.8	157	15	41
A4	0.8	138	35	0.8
A5	34	109	68	0.8
A6	151	0.8	11	9
A7	133	0.8	0.8	69

Overall (Length x Width): 164 mm x 75 mm						
Overall Diagonal: 170 mm/Display Diagonal: 161mm						
Distance of the Antenna to the EUT surface/edge						
Antenna	Back Side	Front side	Left Edge	Right Edge	Top Edge	Bottom Edge
Antenna 1 (A1)	<25mm	<25mm	<25mm	>25mm	>25mm	>25mm
Antenna 4 (A4)	<25mm	<25mm	>25mm	<25mm	<25mm	>25mm
Antenna 6 (A6)	<25mm	<25mm	<25mm	<25mm	>25mm	<25mm
Antenna 7 (A7)	<25mm	<25mm	<25mm	>25mm	>25mm	<25mm
Hotspot mode, Positions for SAR tests						
Mode	Back Side	Front side	Left Edge	Right Edge	Top Edge	Bottom Edge
Antenna 1 (A1)	Yes	Yes	Yes	NA	NA	NA
Antenna 4 (A4)	Yes	Yes	NA	Yes	Yes	NA
Antenna 6 (A6)	Yes	Yes	Yes	Yes	NA	Yes
Antenna 7 (A7)	Yes	Yes	Yes	NA	NA	Yes
Note: 1. Per KDB 941225 D06, when the overall device length and width are $\geq 9\text{cm} \times 5\text{cm}$, the test distance is 10mm. SAR must be measured for all sides and surfaces with a transmitting antenna located within 25mm from that surface						



or edge.

2. For smart phones with an overall diagonal dimension is 170mm. Per KDB 648474 D04, for smart phones with a display diagonal dimension > 15.0 cm or an overall diagonal dimension > 16.0 cm, product specific 10-g SAR must be tested as a phablet to determine SAR compliance. For Phablet, Since hotspot mode 1-g *reported* SAR < 1.2 W/kg, product specific 10-g SAR is no required.

3. Per FCC KDB 447498 D01,

for each exposure position, testing of other required channels within the operating mode of a frequency band is not required when the reported 1-g or 10-g SAR for the mid-band or highest output power channel is:

- a) ≤ 0.8 W/kg or 2.0 W/kg, for 1-g or 10-g respectively, when the transmission band is ≤ 100 MHz
- b) ≤ 0.6 W/kg or 1.5 W/kg, for 1-g or 10-g respectively, when the transmission band is between 100 MHz and 200 MHz.
- c) ≤ 0.4 W/kg or 1.0 W/kg, for 1-g or 10-g respectively, when the transmission band is ≥ 200 MHz.

4. When the original highest measured SAR is ≥ 0.80 W/kg, the measurement was repeated once.



10.2 Measured SAR Results

Table 3: LTE Band 2 (20MHz, Antenna 6)

Test Position	Power Reduction	Duty Cycle	RB allocation	RB offset	Channel/Frequency (MHz)	Tune-up (dBm)	Measured power (dBm)	Limit of SAR 1.6 W/kg (mW/g)				Plot No.
								Measured SAR1g	Power Drift (dB)	Scaling Factor	Report SAR1g	
Head SAR (QPSK)												
Left Cheek	Normal	1:1	1	0	18900/1880	25.00	24.23	0.064	-0.155	1.19	0.076	/
Left Tilt	Normal	1:1	1	0	18900/1880	25.00	24.23	0.027	0.035	1.19	0.032	/
Right Cheek	Normal	1:1	1	0	18900/1880	25.00	24.23	0.042	0.084	1.19	0.050	/
Right Tilt	Normal	1:1	1	0	18900/1880	25.00	24.23	0.040	0.084	1.19	0.048	/
Left Cheek	Normal	1:1	50%	50	18700/1860	24.00	23.50	0.082	0.130	1.12	0.092	13
Left Tilt	Normal	1:1	50%	50	18700/1860	24.00	23.50	0.036	0.022	1.12	0.040	/
Right Cheek	Normal	1:1	50%	50	18700/1860	24.00	23.50	0.026	-0.158	1.12	0.029	/
Right Tilt	Normal	1:1	50%	50	18700/1860	24.00	23.50	0.049	0.055	1.12	0.055	/
Body-worn SAR (QPSK, Distance 15mm)												
Back Side	Level 2	1:1	1	50	18700/1860	23.50	23.34	1.000	-0.190	1.04	1.038	/
	Level 2	1:1	1	0	18900/1880	23.50	23.15	1.300	0.090	1.08	1.409	/
	Level 2	1:1	1	0	19100/1900	23.50	23.18	1.390	-0.090	1.08	1.496	14
Front Side	Level 2	1:1	1	50	18700/1860	23.50	23.34	0.394	-0.050	1.04	0.409	/
Back Side	Level 2	1:1	50%	0	18700/1860	22.50	22.42	0.885	0.180	1.02	0.901	/
	Level 2	1:1	50%	25	18900/1880	22.50	22.35	1.000	-0.080	1.04	1.035	/
	Level 2	1:1	50%	25	19100/1900	22.50	22.38	1.110	-0.130	1.03	1.141	/
Front Side	Level 2	1:1	50%	0	18700/1860	22.50	22.42	0.337	-0.110	1.02	0.343	/
Back Side	Level 2	1:1	100%	0	18700/1860	22.50	22.41	0.734	-0.130	1.02	0.749	/
Back Side repeated	Level 2	1:1	1	0	19100/1900	23.50	23.18	1.320	0.040	1.08	1.421	/
Back Side	Level 3	1:1	1	0	18700/1860	23.00	22.88	0.926	0.020	1.03	0.952	/
	Level 3	1:1	1	0	18900/1880	23.00	22.69	0.982	0.038	1.07	1.055	/
	Level 3	1:1	1	0	19100/1900	23.00	22.72	1.110	-0.033	1.07	1.184	/
Back Side	Level 3	1:1	50%	0	18700/1860	22.00	21.96	0.726	0.020	1.01	0.733	/
	Level 3	1:1	50%	25	18900/1880	22.00	21.89	0.803	0.015	1.03	0.824	/
	Level 3	1:1	50%	25	19100/1900	22.00	21.92	0.866	0.034	1.02	0.882	/
Back Side	Level 3	1:1	100%	0	18900/1880	22.00	21.79	0.642	0.060	1.05	0.674	/
Hotspot SAR(QPSK, Distance 10mm)												
Back Side	Level 4	1:1	1	99	18900/1880	19.50	19.23	0.751	-0.022	1.06	0.799	/
Front Side	Level 4	1:1	1	99	18900/1880	19.50	19.23	0.288	-0.090	1.06	0.306	/
Left Edge	Level 4	1:1	1	99	18900/1880	19.50	19.23	0.019	-0.070	1.06	0.020	/
Right Edge	Level 4	1:1	1	99	18900/1880	19.50	19.23	0.036	-0.150	1.06	0.038	/
Top Edge	N/A	N/A	N/A	N/A	N/A	N/A	N/A	N/A	N/A	N/A	N/A	N/A



Test Position	Power Reduction	Duty Cycle	RB allocation	RB offset	Channel/Frequency (MHz)	Tune-up (dBm)	Measured power (dBm)	Limit of SAR 4.0 W/kg (mW/g)				Plot No.
								Measured SAR10g	Power Drift (dB)	Scaling Factor	Report SAR10g	
Product Specific 10-g SAR (QPSK, Distance 0mm)												
Bottom Edge	Level 4	1:1	1	0	18700/1860	19.50	19.22	0.962	0.045	1.07	1.026	15
	Level 4	1:1	1	99	18900/1880	19.50	19.23	0.756	0.180	1.06	0.804	/
	Level 4	1:1	1	50	19100/1900	19.50	19.20	0.890	0.036	1.07	0.954	/
Back Side	Level 4	1:1	50%	25	19100/1900	18.50	18.39	0.602	-0.025	1.03	0.617	/
Front Side	Level 4	1:1	50%	25	19100/1900	18.50	18.39	0.238	0.160	1.03	0.244	/
Left Edge	Level 4	1:1	50%	25	19100/1900	18.50	18.39	0.018	-0.073	1.03	0.018	/
Right Edge	Level 4	1:1	50%	25	19100/1900	18.50	18.39	0.029	-0.034	1.03	0.030	/
Top Edge	N/A	N/A	N/A	N/A	N/A	N/A	N/A	N/A	N/A	N/A	N/A	N/A
Bottom Edge	Level 4	1:1	50%	25	19100/1900	18.50	18.39	0.588	0.050	1.03	0.603	/
Bottom Edge	Level 4	1:1	100%	0	19100/1900	18.50	18.28	0.552	0.051	1.05	0.581	/
Additional SAR test at a conservative distance (triggering distance minus 1mm) (QPSK, Distance 8mm)												
Back Side	Level 7	1:1	1	0	18700/1860	22.50	22.17	2.330	-0.030	1.08	2.514	16
	Level 7	1:1	1	99	18900/1880	22.50	22.20	2.140	0.060	1.07	2.293	/
	Level 7	1:1	1	0	19100/1900	22.50	22.10	2.180	-0.021	1.10	2.390	/
Bottom Edge	Level 7	1:1	1	99	18900/1880	22.50	22.20	1.810	0.099	1.07	1.939	/
Back Side	Level 7	1:1	50%	25	19100/1900	21.50	21.29	1.730	0.082	1.05	1.816	/
Bottom Edge	Level 7	1:1	50%	25	19100/1900	21.50	21.29	1.390	0.102	1.05	1.459	/
Back Side	Level 7	1:1	100%	0	18700/1860	21.50	21.29	1.850	-0.030	1.05	1.942	/

Note: 1. The value with blue color is the maximum SAR Value of each test band.
 2. For QPSK with 100% RB allocation, SAR is required when and the highest reported SAR for 1 RB and 50% RB allocation in are \geq 50% limit(1g).

Measurement Variability				
Test Position	Channel/ Frequency(MHz)	MAX Measured SAR _{1g} (W/kg)	1 st Repeated SAR _{1g} (W/kg)	Ratio
Body-worn SAR				
Back Side	19100/1900	1.390	1.320	1.05

Note: 1) A second repeated measurement was performed only if the ratio of largest to smallest SAR for the original and first repeated measurements was > 1.20 or when the original or repeated measurement was \geq 1.45 W/kg (~ 10% from the 1-g SAR limit).
 2) A third repeated measurement was performed only if the original, first or second repeated measurement was \geq 1.5 W/kg and the ratio of largest to smallest SAR for the original, first and second repeated measurements is > 1.20.



MAX Adjusted SAR

Test Position	Power Reduction	RB allocation	offset	Channel/Frequency (MHz)	Full power (dBm)	Tune-up (dBm)	Report SAR10g (mW/g)	Scaling Factor	Full power Report SAR10g (mW/g)	0mm SAR
Back Side	Level 4	1	99	18900/1880	23.50	19.50	0.799	2.51	2.007	Yes
Front Side	Level 4	1	99	18900/1880	23.50	19.50	0.306	2.51	0.770	No
Left Edge	Level 4	1	99	18900/1880	23.50	19.50	0.020	2.51	0.050	No
Right Edge	Level 4	1	99	18900/1880	23.50	19.50	0.038	2.51	0.095	No
Bottom Edge	Level 4	1	99	18900/1880	23.50	19.50	0.804	2.51	2.021	Yes
Back Side	Level 4	50%	25	19100/1900	22.50	18.50	0.617	2.51	1.551	Yes
Front Side	Level 4	50%	25	19100/1900	22.50	18.50	0.244	2.51	0.613	No
Left Edge	Level 4	50%	25	19100/1900	22.50	18.50	0.018	2.51	0.046	No
Right Edge	Level 4	50%	25	19100/1900	22.50	18.50	0.030	2.51	0.075	No
Bottom Edge	Level 4	50%	25	19100/1900	22.50	18.50	0.603	2.51	1.515	Yes

Note: According to 648474 D04 Handset SAR v01r03, For Phablet, Since hotspot mode 1-g reported SAR < 1.2 W/kg, Product Specific 10-g SAR is not required.



Table 4: LTE (EN-DC) Band 2 (20MHz, Antenna 7)

Test Position	Power Reduction	Duty Cycle	RB allocation	RB offset	Channel/Frequency (MHz)	Tune-up (dBm)	Measured power (dBm)	Limit of SAR 1.6 W/kg (mW/g)				Plot No.
								Measured SAR1g	Power Drift (dB)	Scaling Factor	Report SAR1g	
Head SAR (QPSK)												
Left Cheek	Normal	1:1	1	99	18900/1880	24.00	23.29	0.054	-0.051	1.18	0.063	/
Left Tilt	Normal	1:1	1	99	18900/1880	24.00	23.29	0.042	-0.070	1.18	0.049	/
Right Cheek	Normal	1:1	1	99	18900/1880	24.00	23.29	0.058	-0.078	1.18	0.068	17
Right Tilt	Normal	1:1	1	99	18900/1880	24.00	23.29	0.035	0.150	1.18	0.041	/
Left Cheek	Normal	1:1	50%	50	18700/1860	23.00	22.72	0.047	-0.055	1.07	0.050	/
Left Tilt	Normal	1:1	50%	50	18700/1860	23.00	22.72	0.033	0.000	1.07	0.035	/
Right Cheek	Normal	1:1	50%	50	18700/1860	23.00	22.72	0.051	0.085	1.07	0.055	/
Right Tilt	Normal	1:1	50%	50	18700/1860	23.00	22.72	0.028	0.028	1.07	0.030	/
Body-worn SAR (QPSK, Distance 15mm)												
Back Side	Level 2	1:1	1	50	18700/1860	23.50	23.34	0.117	-0.150	1.04	0.121	/
Front Side	Level 2	1:1	1	50	18700/1860	23.50	23.34	0.120	0.110	1.04	0.125	18
Back Side	Level 2	1:1	50%	0	18700/1860	22.50	22.42	0.094	0.000	1.02	0.095	/
Front Side	Level 2	1:1	50%	0	18700/1860	22.50	22.42	0.106	-0.150	1.02	0.108	/
Hotspot SAR(QPSK, Distance 10mm)												
Back Side	Level 4	1:1	1	99	18900/1880	19.50	19.23	0.160	-0.150	1.06	0.170	19
Front Side	Level 4	1:1	1	99	18900/1880	19.50	19.23	0.158	0.170	1.06	0.168	/
Left Edge	Level 4	1:1	1	99	18900/1880	19.50	19.23	0.048	-0.06	1.06	0.051	/
Right Edge	Level 4	1:1	1	99	18900/1880	19.50	19.23	0.100	0.090	1.06	0.106	/
Top Edge	N/A	N/A	N/A	N/A	N/A	N/A	N/A	N/A	N/A	N/A	N/A	N/A
Bottom Edge	Level 4	1:1	1	99	18900/1880	19.50	19.23	0.113	-0.060	1.06	0.120	/
Back Side	Level 4	1:1	50%	25	19100/1900	18.50	18.39	0.137	0.050	1.03	0.141	/
Front Side	Level 4	1:1	50%	25	19100/1900	18.50	18.39	0.117	0.010	1.03	0.120	/
Left Edge	Level 4	1:1	50%	25	19100/1900	18.50	18.39	0.046	-0.022	1.03	0.047	/
Right Edge	Level 4	1:1	50%	25	19100/1900	18.50	18.39	0.078	0.190	1.03	0.080	/
Top Edge	N/A	N/A	N/A	N/A	N/A	N/A	N/A	N/A	N/A	N/A	N/A	N/A
Bottom Edge	Level 4	1:1	50%	25	19100/1900	18.50	18.39	0.079	-0.025	1.03	0.081	/

Note: 1. The value with blue color is the maximum SAR Value of each test band.

2. For QPSK with 100% RB allocation, SAR is required when and the highest reported SAR for 1 RB and 50% RB allocation in are $\geq 50\%$ limit(1g).



Table 5: LTE Band 4 (20MHz, Antenna 6)

Test Position	Power Reduction	Duty Cycle	RB allocation	RB offset	Channel/Frequency (MHz)	Tune-up (dBm)	Measured power (dBm)	Limit of SAR 1.6 W/kg (mW/g)				Plot No.
								Measured SAR1g	Power Drift (dB)	Scaling Factor	Report SAR1g	
Head SAR (QPSK)												
Left Cheek	Normal	1:1	1	0	20175/1732.5	25.00	24.37	0.122	0.037	1.16	0.141	20
Left Tilt	Normal	1:1	1	0	20175/1732.5	25.00	24.37	0.033	-0.030	1.16	0.039	/
Right Cheek	Normal	1:1	1	0	20175/1732.5	25.00	24.37	0.064	0.056	1.16	0.074	/
Right Tilt	Normal	1:1	1	0	20175/1732.5	25.00	24.37	0.033	0.028	1.16	0.038	/
Left Cheek	Normal	1:1	50%	25	20050/1720	24.00	23.51	0.089	0.080	1.12	0.100	/
Left Tilt	Normal	1:1	50%	25	20050/1720	24.00	23.51	0.036	0.035	1.12	0.040	/
Right Cheek	Normal	1:1	50%	25	20050/1720	24.00	23.51	0.057	0.105	1.12	0.064	/
Right Tilt	Normal	1:1	50%	25	20050/1720	24.00	23.51	0.029	0.180	1.12	0.032	/
Body-worn SAR (QPSK, Distance 15mm)												
Back Side	Normal	1:1	1	50	20050/1720	25.00	24.20	0.357	-0.070	1.20	0.429	/
	Normal	1:1	1	0	20175/1732.5	25.00	24.37	0.576	-0.020	1.16	0.666	21
	Normal	1:1	1	99	20300/1745	25.00	24.15	0.258	0.100	1.22	0.314	/
Front Side	Normal	1:1	1	0	20175/1732.5	25.00	24.37	0.446	0.131	1.16	0.516	/
Back Side	Normal	1:1	50%	25	20050/1720	24.00	23.51	0.354	0.040	1.12	0.396	/
Front Side	Normal	1:1	50%	25	20050/1720	24.00	23.51	0.350	0.140	1.12	0.392	/
Hotspot SAR(QPSK, Distance 10mm)												
Back Side	Level 5	1:1	1	0	20300/1745	22.50	22.42	0.782	-0.041	1.02	0.797	/
Front Side	Level 5	1:1	1	0	20300/1745	22.50	22.42	0.497	-0.020	1.02	0.506	/
Left Edge	Level 5	1:1	1	0	20300/1745	22.50	22.42	0.047	-0.033	1.02	0.048	/
Right Edge	Level 5	1:1	1	0	20300/1745	22.50	22.42	0.026	-0.046	1.02	0.027	/
Top Edge	N/A	N/A	N/A	N/A	N/A	N/A	N/A	N/A	N/A	N/A	N/A	N/A
Bottom Edge	Level 5	1:1	1	0	20050/1720	22.50	22.29	0.886	0.170	1.05	0.930	/
	Level 5	1:1	1	0	20175/1732.5	22.50	22.31	1.060	0.050	1.04	1.107	22
	Level 5	1:1	1	0	20300/1745	22.50	22.42	0.937	-0.070	1.02	0.954	/
Back Side	Level 5	1:1	50%	0	20175/1732.5	21.50	21.48	0.648	-0.180	1.00	0.651	/
Front Side	Level 5	1:1	50%	0	20175/1732.5	21.50	21.48	0.407	0.050	1.00	0.409	/
Left Edge	Level 5	1:1	50%	0	20175/1732.5	21.50	21.48	0.032	-0.047	1.00	0.032	/
Right Edge	Level 5	1:1	50%	0	20175/1732.5	21.50	21.48	0.025	-0.059	1.00	0.026	/
Top Edge	N/A	N/A	N/A	N/A	N/A	N/A	N/A	N/A	N/A	N/A	N/A	N/A
Bottom Edge	Level 5	1:1	50%	0	20175/1732.5	21.50	21.48	0.773	-0.100	1.00	0.777	/
Bottom Edge	Level 5	1:1	100%	0	20050/1720	21.50	21.45	0.738	0.024	1.01	0.747	/
Bottom Edge repeated	Level 5	1:1	1	0	20175/1732.5	22.50	22.31	0.998	-0.028	1.04	1.043	/



Test Position	Power Reduction	Duty Cycle	RB allocation	RB offset	Channel/Frequency (MHz)	Tune-up (dBm)	Measured power (dBm)	Limit of SAR 4.0 W/kg (mW/g)				Plot No.
								Measured SAR10g	Power Drift (dB)	Scaling Factor	Report SAR10g	
Product Specific 10-g SAR (QPSK, Distance 0mm)												
Back Side	Level 5	1:1	1	0	20300/1745	22.50	22.42	1.120	-0.029	1.02	1.141	/
Bottom Edge	Level 5	1:1	1	0	20050/1720	22.50	22.29	2.160	0.036	1.05	2.267	/
	Level 5	1:1	1	0	20175/1732.5	22.50	22.31	2.260	0.034	1.04	2.361	/
	Level 5	1:1	1	0	20300/1745	22.50	22.42	2.470	0.061	1.02	2.516	23
Back Side	Level 5	1:1	50%	0	20175/1732.5	21.50	21.48	0.843	0.036	1.00	0.847	/
Bottom Edge	Level 5	1:1	50%	0	20050/1720	21.50	21.38	1.910	0.035	1.03	1.964	/
	Level 5	1:1	50%	0	20175/1732.5	21.50	21.48	2.060	0.060	1.00	2.070	/
	Level 5	1:1	50%	0	20300/1745	21.50	21.46	1.920	0.041	1.01	1.938	/
Bottom Edge	Level 5	1:1	100%	0	20050/1720	21.50	21.45	1.960	-0.031	1.01	1.983	/
Additional SAR test at a conservative distance (triggering distance minus 1mm) (QPSK, Distance 8mm)												
Back Side	Normal	1:1	1	0	20175/1732.5	25.00	24.37	0.935	-0.080	1.16	1.081	/
Bottom Edge	Normal	1:1	1	0	20175/1732.5	25.00	24.37	1.180	0.030	1.16	1.364	/
Back Side	Normal	1:1	50%	25	20050/1720	24.00	23.51	0.584	-0.070	1.12	0.654	/
Bottom Edge	Normal	1:1	50%	25	20050/1720	24.00	23.51	0.731	0.035	1.12	0.818	/
<p>Note: 1. The value with blue color is the maximum SAR Value of each test band.</p> <p>2. For QPSK with 100% RB allocation, SAR is required when and the highest reported SAR for 1 RB and 50% RB allocation in are \geq 50% limit(1g).</p>												

Measurement Variability				
Test Position	Channel/ Frequency(MHz)	MAX Measured SAR _{1g} (W/kg)	1 st Repeated SAR _{1g} (W/kg)	Ratio
Hotspot SAR				
Bottom Edge	20050/1720	1.060	0.738	1.44
<p>Note: 1) A second repeated measurement was performed only if the ratio of largest to smallest SAR for the original and first repeated measurements was > 1.20 or when the original or repeated measurement was \geq 1.45 W/kg (~ 10% from the 1-g SAR limit).</p> <p>2) A third repeated measurement was performed only if the original, first or second repeated measurement was \geq 1.5 W/kg and the ratio of largest to smallest SAR for the original, first and second repeated measurements is > 1.20.</p>				



MAX Adjusted SAR

Test Position	Power Reduction	RB allocation	offset	Channel/Frequency (MHz)	Full power (dBm)	Tune-up (dBm)	Report SAR1g (mW/g)	Scaling Factor	Full power Report SAR1g (mW/g)	0mm SAR
Back Side	Level 5	1	0	20300/1745	25.00	22.50	0.797	1.78	1.419	Yes
Front Side	Level 5	1	0	20300/1745	25.00	22.50	0.506	1.78	0.900	No
Left Edge	Level 5	1	0	20300/1745	25.00	22.50	0.048	1.78	0.085	No
Right Edge	Level 5	1	0	20300/1745	25.00	22.50	0.027	1.78	0.047	No
Bottom Edge	Level 5	1	0	20300/1745	25.00	22.50	0.954	1.78	1.697	Yes
Back Side	Level 5	50%	0	20175/1732.5	24.00	21.50	0.651	1.78	1.158	No
Front Side	Level 5	50%	0	20175/1732.5	24.00	21.50	0.409	1.78	0.727	No
Left Edge	Level 5	50%	0	20175/1732.5	24.00	21.50	0.032	1.78	0.057	No
Right Edge	Level 5	50%	0	20175/1732.5	24.00	21.50	0.026	1.78	0.045	No
Bottom Edge	Level 5	50%	0	20175/1732.5	24.00	21.50	0.777	1.78	1.381	Yes

Note: According to 648474 D04 Handset SAR v01r03, For Phablet, Since hotspot mode 1-g reported SAR < 1.2 W/kg, Product Specific 10-g SAR is not required.



Table 6: LTE Band 5 (10MHz, Antenna 4)

Test Position	Power Reduction	Duty Cycle	RB allocation	RB offset	Channel/Frequency (MHz)	Tune-up (dBm)	Measured power (dBm)	Limit of SAR 1.6 W/kg (mW/g)				Plot No.
								Measured SAR1g	Power Drift (dB)	Scaling Factor	Report SAR1g	
Head SAR (QPSK)												
Left Cheek	Normal	1:1	1	49	20450/829	25.00	24.54	0.901	0.020	1.11	1.002	/
	Normal	1:1	1	25	20525/836.5	25.00	24.55	0.920	-0.010	1.11	1.020	/
	Normal	1:1	1	25	20600/844	25.00	24.58	0.932	0.080	1.10	1.027	/
Left Tilt	Normal	1:1	1	49	20450/829	25.00	24.54	0.711	0.030	1.11	0.790	/
	Normal	1:1	1	25	20525/836.5	25.00	24.55	0.765	-0.124	1.11	0.849	/
	Normal	1:1	1	25	20600/844	25.00	24.58	0.791	0.020	1.10	0.871	/
Right Cheek	Normal	1:1	1	49	20450/829	25.00	24.54	1.133	0.011	1.11	1.260	/
	Normal	1:1	1	25	20525/836.5	25.00	24.55	1.200	-0.010	1.11	1.331	/
	Normal	1:1	1	25	20600/844	25.00	24.58	1.290	0.030	1.10	1.421	24
Right Tilt	Normal	1:1	1	49	20450/829	25.00	24.54	1.000	0.023	1.11	1.112	/
	Normal	1:1	1	25	20525/836.5	25.00	24.55	1.120	0.014	1.11	1.242	/
	Normal	1:1	1	25	20600/844	25.00	24.58	1.190	0.010	1.10	1.311	/
Left Cheek	Normal	1:1	50%	13	20600/844	24.00	23.78	0.709	-0.090	1.05	0.746	/
Left Tilt	Normal	1:1	50%	13	20600/844	24.00	23.78	0.622	0.000	1.05	0.654	/
Right Cheek	Normal	1:1	50%	25	20450/829	24.00	23.67	0.921	0.020	1.08	0.994	/
	Normal	1:1	50%	0	20525/836.5	24.00	23.67	1.061	-0.128	1.08	1.145	/
	Normal	1:1	50%	13	20600/844	24.00	23.78	1.080	0.020	1.05	1.136	/
Right Tilt	Normal	1:1	50%	25	20450/829	24.00	23.67	0.881	0.021	1.08	0.951	/
	Normal	1:1	50%	0	20525/836.5	24.00	23.67	0.928	0.017	1.08	1.001	/
	Normal	1:1	50%	13	20600/844	24.00	23.78	0.940	0.010	1.05	0.989	/
Right Cheek repeated	Normal	1:1	1	25	20600/844	25.00	24.58	1.210	0.038	1.10	1.333	/
Right Cheek (CA_5B)	Normal	1:1	1	49	20450/829	25.00	24.30	0.958	0.024	1.17	1.126	/
		1:1	1	0	20549/838.9							
Left Cheek	level 1	1:1	1	0	20600/844	24.50	24.09	0.673	0.050	1.10	0.740	/
Left Tilt	level 1	1:1	1	0	20600/844	24.50	24.09	0.533	-0.040	1.10	0.586	/
Right Cheek	level 1	1:1	1	49	20450/829	24.50	24.03	0.943	-0.100	1.11	1.051	/
	level 1	1:1	1	49	20525/836.5	24.50	24.07	0.924	-0.050	1.10	1.020	/
	level 1	1:1	1	0	20600/844	24.50	24.09	0.876	-0.040	1.10	0.963	/
Right Tilt	level 1	1:1	1	49	20450/829	24.50	24.03	0.984	-0.020	1.11	1.096	/
	level 1	1:1	1	49	20525/836.5	24.50	24.07	0.986	-0.040	1.10	1.089	/
	level 1	1:1	1	0	20600/844	24.50	24.09	1.050	-0.040	1.10	1.154	/
Left Cheek	level 1	1:1	50%	13	20525/836.5	23.50	23.22	0.556	-0.070	1.07	0.593	/
Left Tilt	level 1	1:1	50%	13	20525/836.5	23.50	23.22	0.431	0.000	1.07	0.460	/
Right Cheek	level 1	1:1	50%	13	20450/829	23.50	23.12	0.776	-0.070	1.09	0.847	/



	level 1	1:1	50%	13	20525/836.5	23.50	23.22	0.916	-0.050	1.07	0.977	/
	level 1	1:1	50%	25	20600/844	23.50	23.17	0.691	-0.030	1.08	0.746	/
Right Tilt	level 1	1:1	50%	13	20450/829	23.50	23.12	0.683	-0.040	1.09	0.745	/
	level 1	1:1	50%	13	20525/836.5	23.50	23.22	0.859	0.020	1.07	0.916	/
	level 1	1:1	50%	25	20600/844	23.50	23.17	0.704	0.020	1.08	0.760	/
Right Cheek	level 1	1:1	100%	0	20450/829	23.50	23.11	0.771	0.000	1.09	0.843	/
	level 1	1:1	100%	0	20525/836.5	23.50	23.09	0.732	-0.050	1.10	0.804	/
	level 1	1:1	100%	0	20600/844	23.50	23.09	0.686	-0.040	1.10	0.754	/

Body-worn SAR (QPSK, Distance 15mm)

Back Side	Normal	1:1	1	25	20600/844	25.00	24.58	0.513	0.100	1.10	0.565	25
Front Side	Normal	1:1	1	25	20600/844	25.00	24.58	0.377	0.030	1.10	0.415	/
Back Side	Normal	1:1	50%	13	20600/844	24.00	23.78	0.405	0.012	1.05	0.426	/
Front Side	Normal	1:1	50%	13	20600/844	24.00	23.78	0.346	0.110	1.05	0.364	/
Back Side (CA_5B)	Normal	1:1	1	49	20450/829	25.00	24.30	0.328	-0.033	1.17	0.385	/
			1	0	20549/838.9							

Hotspot SAR(QPSK, Distance 10mm)

Back Side	Normal	1:1	1	49	20450/829	25.00	24.54	0.541	0.110	1.11	0.601	/
	Normal	1:1	1	25	20525/836.5	25.00	24.55	0.561	0.000	1.11	0.622	/
	Normal	1:1	1	25	20600/844	25.00	24.58	0.609	-0.028	1.10	0.671	26
Front Side	Normal	1:1	1	25	20600/844	25.00	24.58	0.582	-0.027	1.10	0.641	/
Left Edge	Normal	1:1	1	25	20600/844	25.00	24.58	0.450	-0.112	1.10	0.496	/
Right Edge	Normal	1:1	1	25	20600/844	25.00	24.58	0.263	0.044	1.10	0.290	/
Top Edge	Normal	1:1	1	25	20600/844	25.00	24.58	0.471	0.066	1.10	0.519	/
Bottom Edge	N/A	N/A	N/A	N/A	N/A	N/A	N/A	N/A	N/A	N/A	N/A	N/A
Back Side	Normal	1:1	50%	13	20600/844	24.00	23.78	0.587	0.014	1.05	0.618	/
Front Side	Normal	1:1	50%	13	20600/844	24.00	23.78	0.542	0.081	1.05	0.570	/
Left Edge	Normal	1:1	50%	13	20600/844	24.00	23.78	0.423	0.072	1.05	0.445	/
Right Edge	Normal	1:1	50%	13	20600/844	24.00	23.78	0.248	0.052	1.05	0.261	/
Top Edge	Normal	1:1	50%	13	20600/844	24.00	23.78	0.433	0.110	1.05	0.455	/
Bottom Edge	N/A	N/A	N/A	N/A	N/A	N/A	N/A	N/A	N/A	N/A	N/A	N/A
Back Side	Normal	1:1	100%	0	20450/829	24.00	23.78	0.413	0.000	1.05	0.434	/
Back Side (CA_5B)	Normal	1:1	1	49	20450/829	25.00	24.30	0.425	0.018	1.17	0.499	/
			1	0	20549/838.9							

Note: 1.The value with blue color is the maximum SAR Value of each test band.

2.For QPSK with 100% RB allocation, SAR is required when and the highest reported SAR for 1 RB and 50% RB allocation in are $\geq 50\%$ limit(1g).



Measurement Variability				
Test Position	Channel/ Frequency(MHz)	MAX Measured SAR _{1g} (W/kg)	1 st Repeated SAR _{1g} (W/kg)	Ratio
Head SAR				
Right Cheek	20600/844	1.290	1.210	1.07
Note: 1) A second repeated measurement was performed only if the ratio of largest to smallest SAR for the original and first repeated measurements was > 1.20 or when the original or repeated measurement was ≥ 1.45 W/kg (~ 10% from the 1-g SAR limit). 2) A third repeated measurement was performed only if the original, first or second repeated measurement was ≥ 1.5 W/kg and the ratio of largest to smallest SAR for the original, first and second repeated measurements is > 1.20.				



Table 7: LTE Band 12 (10MHz, Antenna 4)

Test Position	Power Reduction	Duty Cycle	RB allocation	RB offset	Channel/Frequency (MHz)	Tune-up (dBm)	Measured power (dBm)	Limit of SAR 1.6 W/kg (mW/g)				Plot No.
								Measured SAR1g	Power Drift (dB)	Scaling Factor	Report SAR1g	
Head SAR (QPSK)												
Left Cheek	Normal	1:1	1	0	23130/711	25.00	24.56	0.072	0.020	1.11	0.079	/
Left Tilt	Normal	1:1	1	0	23130/711	25.00	24.56	0.069	-0.080	1.11	0.076	/
Right Cheek	Normal	1:1	1	0	23130/711	25.00	24.56	0.080	0.011	1.11	0.089	/
Right Tilt	Normal	1:1	1	0	23130/711	25.00	24.56	0.093	0.080	1.11	0.103	/
Left Cheek	Normal	1:1	50%	0	23095/707.5	24.00	23.62	0.083	0.110	1.09	0.090	/
Left Tilt	Normal	1:1	50%	0	23095/707.5	24.00	23.62	0.078	0.170	1.09	0.086	/
Right Cheek	Normal	1:1	50%	0	23095/707.5	24.00	23.62	0.154	0.070	1.09	0.168	27
Right Tilt	Normal	1:1	50%	0	23095/707.5	24.00	23.62	0.124	0.050	1.09	0.135	/
Body-worn SAR (QPSK, Distance 15mm)												
Back Side	Normal	1:1	1	0	23130/711	25.00	24.56	0.060	-0.160	1.11	0.066	28
Front Side	Normal	1:1	1	0	23130/711	25.00	24.56	0.017	-0.013	1.11	0.019	/
Back Side	Normal	1:1	50%	0	23095/707.5	24.00	23.62	0.054	0.026	1.09	0.059	/
Front Side	Normal	1:1	50%	0	23095/707.5	24.00	23.62	0.020	0.033	1.09	0.022	/
Hotspot SAR(QPSK, Distance 10mm)												
Back Side	Normal	1:1	1	0	23130/711	25.00	24.56	0.089	0.090	1.11	0.098	29
Front Side	Normal	1:1	1	0	23130/711	25.00	24.56	0.055	0.050	1.11	0.061	/
Left Edge	Normal	1:1	1	0	23130/711	25.00	24.56	0.001	0.000	1.11	0.001	/
Right Edge	Normal	1:1	1	0	23130/711	25.00	24.56	0.001	0.000	1.11	0.001	/
Top Edge	Normal	1:1	1	0	23130/711	25.00	24.56	0.001	0.000	1.11	0.001	/
Bottom Edge	N/A	N/A	N/A	N/A	N/A	N/A	N/A	N/A	N/A	N/A	N/A	N/A
Back Side	Normal	1:1	50%	0	23095/707.5	24.00	23.62	0.080	0.011	1.09	0.087	/
Front Side	Normal	1:1	50%	0	23095/707.5	24.00	23.62	0.048	0.035	1.09	0.052	/
Left Edge	Normal	1:1	50%	0	23095/707.5	24.00	23.62	0.001	0.000	1.09	0.001	/
Right Edge	Normal	1:1	50%	0	23095/707.5	24.00	23.62	0.001	0.000	1.09	0.001	/
Top Edge	Normal	1:1	50%	0	23095/707.5	24.00	23.62	0.001	0.000	1.09	0.001	/
Bottom Edge	N/A	N/A	N/A	N/A	N/A	N/A	N/A	N/A	N/A	N/A	N/A	N/A

Note: 1. The value with blue color is the maximum SAR Value of each test band.

2. For QPSK with 100% RB allocation, SAR is required when and the highest reported SAR for 1 RB and 50% RB allocation in are $\geq 50\%$ limit(1g).



Table 8: LTE Band 13 (10MHz, Antenna 4)

Test Position	Power Reduction	Duty Cycle	RB allocation	RB offset	Channel/Frequency (MHz)	Tune-up (dBm)	Measured power (dBm)	Limit of SAR 1.6 W/kg (mW/g)				Plot No.
								Measured SAR1g	Power Drift (dB)	Scaling Factor	Report SAR1g	
Head SAR (QPSK)												
Left Cheek	Normal	1:1	1	25	23230/782	25.00	24.61	0.346	0.030	1.09	0.379	/
Left Tilt	Normal	1:1	1	25	23230/782	25.00	24.61	0.401	0.050	1.09	0.439	/
Right Cheek	Normal	1:1	1	25	23230/782	25.00	24.61	0.771	0.000	1.09	0.843	/
Right Tilt	Normal	1:1	1	25	23230/782	25.00	24.61	0.661	0.000	1.09	0.723	/
Left Cheek	Normal	1:1	50%	25	23230/782	24.00	23.80	0.271	0.020	1.05	0.284	/
Left Tilt	Normal	1:1	50%	25	23230/782	24.00	23.80	0.312	0.000	1.05	0.327	/
Right Cheek	Normal	1:1	50%	25	23230/782	24.00	23.80	0.634	-0.030	1.05	0.664	/
Right Tilt	Normal	1:1	50%	25	23230/782	24.00	23.80	0.535	0.040	1.05	0.560	/
Right Cheek	Normal	1:1	100%	0	23230/782	24.00	23.69	0.816	0.060	1.07	0.876	30
Body-worn SAR (QPSK, Distance 15mm)												
Back Side	Normal	1:1	1	25	23230/782	25.00	24.61	0.334	-0.035	1.09	0.365	/
Front Side	Normal	1:1	1	25	23230/782	25.00	24.61	0.215	0.030	1.09	0.235	/
Back Side	Normal	1:1	50%	25	23230/782	24.00	23.80	0.563	0.110	1.05	0.590	31
Front Side	Normal	1:1	50%	25	23230/782	24.00	23.80	0.196	0.021	1.05	0.205	/
Hotspot SAR(QPSK, Distance 10mm)												
Back Side	Normal	1:1	1	25	23230/782	25.00	24.61	0.592	0.050	1.09	0.648	32
Front Side	Normal	1:1	1	25	23230/782	25.00	24.61	0.330	0.054	1.09	0.361	/
Left Edge	Normal	1:1	1	25	23230/782	25.00	24.61	0.199	0.033	1.09	0.218	/
Right Edge	Normal	1:1	1	25	23230/782	25.00	24.61	0.130	0.021	1.09	0.142	/
Top Edge	Normal	1:1	1	25	23230/782	25.00	24.61	0.237	0.012	1.09	0.259	/
Bottom Edge	N/A	N/A	N/A	N/A	N/A	N/A	N/A	N/A	N/A	N/A	N/A	N/A
Back Side	Normal	1:1	50%	25	23230/782	24.00	23.80	0.433	0.041	1.05	0.453	/
Front Side	Normal	1:1	50%	25	23230/782	24.00	23.80	0.295	0.025	1.05	0.309	/
Left Edge	Normal	1:1	50%	25	23230/782	24.00	23.80	0.190	0.011	1.05	0.199	/
Right Edge	Normal	1:1	50%	25	23230/782	24.00	23.80	0.081	-0.022	1.05	0.085	/
Top Edge	Normal	1:1	50%	25	23230/782	24.00	23.80	0.188	0.023	1.05	0.197	/
Bottom Edge	N/A	N/A	N/A	N/A	N/A	N/A	N/A	N/A	N/A	N/A	N/A	N/A
<p>Note: 1. The value with blue color is the maximum SAR Value of each test band.</p> <p>2. For QPSK with 100% RB allocation, SAR is required when and the highest reported SAR for 1 RB and 50% RB allocation in are $\geq 50\%$ limit(1g).</p>												



Table 9: LTE Band 66 (20MHz, Antenna 6)

Test Position	Power Reduction	Duty Cycle	RB allocation	RB offset	Channel/Frequency (MHz)	Tune-up (dBm)	Measured power (dBm)	Limit of SAR 1.6 W/kg (mW/g)				Plot No.
								Measured SAR1g	Power Drift (dB)	Scaling Factor	Report SAR1g	
Head SAR (QPSK)												
Left Cheek	Normal	1:1	1	0	132322/1745	25.00	24.19	0.045	0.040	1.21	0.055	/
Left Tilt	Normal	1:1	1	0	132322/1745	25.00	24.19	0.027	0.170	1.21	0.033	/
Right Cheek	Normal	1:1	1	0	132322/1745	25.00	24.19	0.045	-0.080	1.21	0.054	/
Right Tilt	Normal	1:1	1	0	132322/1745	25.00	24.19	0.027	0.080	1.21	0.032	/
Left Cheek	Normal	1:1	50%	50	132072/1720	24.00	23.56	0.058	0.022	1.11	0.064	33
Left Tilt	Normal	1:1	50%	50	132072/1720	24.00	23.56	0.024	0.040	1.11	0.027	/
Right Cheek	Normal	1:1	50%	50	132072/1720	24.00	23.56	0.049	0.092	1.11	0.054	/
Right Tilt	Normal	1:1	50%	50	132072/1720	24.00	23.56	0.031	0.034	1.11	0.034	/
Left Cheek (CA_66C)	Normal	1:1	1	99	132322/1745	25.00	23.86	0.022	-0.062	1.30	0.029	/
			1	0	132520/1764.8							
Left Cheek (CA_66B)	Normal	1:1	1	49	132022/1715	25.00	23.85	0.036	0.050	1.30	0.047	/
			1	0	132121/1724.9							
Body-worn SAR (QPSK, Distance 15mm)												
Back Side	Normal	1:1	1	0	132072/1720	25.00	24.17	0.477	-0.022	1.21	0.577	/
	Normal	1:1	1	0	132322/1745	25.00	24.19	0.713	-0.090	1.21	0.859	/
	Normal	1:1	1	0	132572/1770	25.00	23.98	0.609	0.000	1.26	0.770	/
Front Side	Normal	1:1	1	0	132322/1745	25.00	24.19	0.360	0.180	1.21	0.434	/
Back Side	Normal	1:1	50%	50	132072/1720	24.00	23.56	0.739	0.050	1.11	0.818	34
	Normal	1:1	50%	50	132322/1745	24.00	23.26	0.512	0.020	1.19	0.607	/
	Normal	1:1	50%	50	132572/1770	24.00	23.24	0.498	0.020	1.19	0.593	/
Front Side	Normal	1:1	50%	50	132072/1720	24.00	23.56	0.367	0.023	1.11	0.406	/
Back Side repeated	Normal	1:1	1	0	132322/1745	25.00	24.19	0.706	0.069	1.21	0.851	/
Back Side (CA_66C)	Normal	1:1	1	99	132322/1745	25.00	23.86	0.562	0.028	1.30	0.731	/
			1	0	132520/1764.8							
Back Side (CA_66B)	Normal	1:1	1	49	132022/1715	25.00	23.85	0.508	-0.120	1.30	0.662	/
			1	0	132121/1724.9							
Hotspot SAR(QPSK, Distance 10mm)												
Back Side	Level 6	1:1	1	99	132072/1720	23.50	23.19	0.477	0.100	1.07	0.512	/
Front Side	Level 6	1:1	1	99	132072/1720	23.50	23.19	0.350	-0.030	1.07	0.376	/
Left Edge	Level 6	1:1	1	99	132072/1720	23.50	23.19	0.042	0.056	1.07	0.046	/
Right Edge	Level 6	1:1	1	99	132072/1720	23.50	23.19	0.041	0.104	1.07	0.044	/
Top Edge	N/A	N/A	N/A	N/A	N/A	N/A	N/A	N/A	N/A	N/A	N/A	N/A
Bottom Edge	Level 6	1:1	1	99	132072/1720	23.50	23.19	1.100	0.022	1.07	1.181	/
	Level 6	1:1	1	99	132322/1745	23.50	23.12	1.250	0.120	1.09	1.364	35



	Level 6	1:1	1	0	132572/1770	23.50	23.08	1.140	0.170	1.10	1.256	/
Back Side	Level 6	1:1	50%	0	132572/1770	22.50	22.24	0.461	0.050	1.06	0.489	/
Front Side	Level 6	1:1	50%	0	132572/1770	22.50	22.24	0.398	0.010	1.06	0.423	/
Left Edge	Level 6	1:1	50%	0	132572/1770	22.50	22.24	0.038	0.022	1.06	0.040	/
Right Edge	Level 6	1:1	50%	0	132572/1770	22.50	22.24	0.042	0.166	1.06	0.045	/
Top Edge	N/A	N/A	N/A	N/A	N/A	N/A	N/A	N/A	N/A	N/A	N/A	N/A
Bottom Edge	Level 6	1:1	50%	0	132072/1720	22.50	22.21	0.910	0.090	1.07	0.973	/
	Level 6	1:1	50%	25	132322/1745	22.50	22.18	0.927	0.090	1.08	0.998	/
	Level 6	1:1	50%	0	132572/1770	22.50	22.24	0.985	0.140	1.06	1.046	/
Bottom Edge	Level 6	1:1	100%	0	132072/1720	22.50	22.19	1.060	0.012	1.07	1.138	/
	Level 6	1:1	100%	0	132322/1745	22.50	22.25	0.997	0.130	1.06	1.056	/
	Level 6	1:1	100%	0	132572/1770	22.50	22.23	1.150	0.042	1.06	1.224	/
Bottom Edge repeated	Level 6	1:1	1	99	132322/1745	23.50	23.12	1.230	-0.010	1.09	1.342	/
Bottom Edge (CA_66C)	Level 6	1:1	1	99	132322/1745	23.50	22.83	0.994	0.036	1.17	1.160	/
		1:1	1	0	132520/1764.8							
Bottom Edge (CA_66B)	Level 6	1:1	1	49	132622/1775	23.50	22.79	0.927	0.090	1.18	1.092	/
		1:1	1	0	132523/1765.1							
Test Position	Power Reduction	Duty Cycle	RB allocation	RB offset	Channel/Frequency (MHz)	Tune-up (dBm)	Measured power (dBm)	Limit of SAR 4.0 W/kg (mW/g)				Plot No.
								Measured SAR10g	Power Drift (dB)	Scaling Factor	Report SAR10g	
Product Specific 10-g SAR (QPSK, Distance 0mm)												
Bottom Edge	Level 6	1:1	1	99	132072/1720	23.50	23.19	2.940	0.081	1.07	3.158	/
	Level 6	1:1	1	99	132322/1745	23.50	23.12	3.160	0.067	1.09	3.449	/
	Level 6	1:1	1	0	132572/1770	23.50	23.08	3.320	0.061	1.10	3.657	36
Bottom Edge	Level 6	1:1	50%	0	132072/1720	22.50	22.21	2.590	0.055	1.07	2.769	/
	Level 6	1:1	50%	25	132322/1745	22.50	22.18	2.470	0.052	1.08	2.659	/
	Level 6	1:1	50%	0	132572/1770	22.50	22.24	2.520	0.110	1.06	2.675	/
Bottom Edge	Level 6	1:1	100%	0	132072/1720	22.50	22.19	2.380	0.010	1.07	2.556	/
	Level 6	1:1	100%	0	132322/1745	22.50	22.25	2.510	-0.033	1.06	2.659	/
	Level 6	1:1	100%	0	132572/1770	22.50	22.23	2.360	0.024	1.06	2.511	/
Bottom Edge (CA_66C)	Level 6	1:1	1	99	132322/1745	23.50	22.83	2.820	0.060	1.17	3.290	/
		1:1	1	0	132520/1764.8							
Bottom Edge (CA_66B)	Level 6	1:1	1	49	132622/1775	23.50	22.79	6.840	0.052	1.18	3.509	/
		1:1	1	0	132523/1765.1							
Additional SAR test at a conservative distance (triggering distance minus 1mm) (QPSK, Distance 8mm)												
Bottom Edge	Normal	1:1	1	0	132322/1745	25.00	24.19	0.774	0.049	1.21	0.933	/
Bottom Edge	Normal	1:1	50%	50	132072/1720	24.00	23.56	1.100	0.031	1.11	1.217	/

Note: 1. The value with blue color is the maximum SAR Value of each test band.

2. For QPSK with 100% RB allocation, SAR is required when and the highest reported SAR for 1 RB and 50% RB allocation in are \geq



50% limit(1g).

Measurement Variability				
Test Position	Channel/ Frequency(MHz)	MAX Measured SAR _{1g} (W/kg)	1 st Repeated SAR _{1g} (W/kg)	Ratio
Body-worn SAR				
Back Side	132322/1745	0.739	0.706	1.05
Hotspot SAR				
Bottom Edge	132322/1745	1.250	1.230	1.02

Note: 1) A second repeated measurement was performed only if the ratio of largest to smallest SAR for the original and first repeated measurements was > 1.20 or when the original or repeated measurement was ≥ 1.45 W/kg (~ 10% from the 1-g SAR limit).
2) A third repeated measurement was performed only if the original, first or second repeated measurement was ≥ 1.5 W/kg and the ratio of largest to smallest SAR for the original, first and second repeated measurements is > 1.20.

MAX Adjusted SAR										
Test Position	Power Reduction	RB allocation	offset	Channel/ Frequency (MHz)	Full power (dBm)	Tune-up (dBm)	Report SAR _{1g} (mW/g)	Scaling Factor	Full power Report SAR _{1g} (mW/g)	0mm SAR
Back Side	Level 6	1	99	132072/1720	25.00	23.50	0.512	1.41	0.724	No
Front Side	Level 6	1	99	132072/1720	25.00	23.50	0.376	1.41	0.531	No
Left Edge	Level 6	1	99	132072/1720	25.00	23.50	0.046	1.41	0.064	No
Right Edge	Level 6	1	99	132072/1720	25.00	23.50	0.044	1.41	0.062	No
Bottom Edge	Level 6	1	99	132072/1720	25.00	23.50	1.181	1.41	1.669	Yes
Back Side	Level 6	50%	0	132572/1770	24.00	22.50	0.489	1.41	0.691	No
Front Side	Level 6	50%	0	132572/1770	24.00	22.50	0.423	1.41	0.597	No
Left Edge	Level 6	50%	0	132572/1770	24.00	22.50	0.040	1.41	0.056	No
Right Edge	Level 6	50%	0	132572/1770	24.00	22.50	0.045	1.41	0.063	No
Bottom Edge	Level 6	50%	0	132572/1770	24.00	22.50	1.046	1.41	1.477	Yes

Note: According to 648474 D04 Handset SAR v01r03, For Phablet, Since hotspot mode 1-g reported SAR < 1.2 W/kg, Product Specific 10-g SAR is not required.



Table 10: LTE (EN-DC) Band 66 (20MHz, Antenna 7)

Test Position	Power Reduction	Duty Cycle	RB allocation	RB offset	Channel/Frequency (MHz)	Tune-up (dBm)	Measured power (dBm)	Limit of SAR 1.6 W/kg (mW/g)				Plot No.
								Measured SAR1g	Power Drift (dB)	Scaling Factor	Report SAR1g	
Head SAR (QPSK)												
Left Cheek	Normal	1:1	1	50	132572/1770	24.00	23.54	0.118	-0.160	1.11	0.131	/
Left Tilt	Normal	1:1	1	50	132572/1770	24.00	23.54	0.083	0.000	1.11	0.092	/
Right Cheek	Normal	1:1	1	50	132572/1770	24.00	23.54	0.102	-0.040	1.11	0.113	/
Right Tilt	Normal	1:1	1	50	132572/1770	24.00	23.54	0.089	0.057	1.11	0.099	/
Left Cheek	Normal	1:1	50%	25	132322/1745	23.00	22.81	0.082	0.036	1.04	0.086	/
Left Tilt	Normal	1:1	50%	25	132322/1745	23.00	22.81	0.063	-0.042	1.04	0.066	/
Right Cheek	Normal	1:1	50%	25	132322/1745	23.00	22.81	0.131	0.029	1.04	0.137	37
Right Tilt	Normal	1:1	50%	25	132322/1745	23.00	22.81	0.069	-0.010	1.04	0.072	/
Body-worn SAR (QPSK, Distance 15mm)												
Back Side	Normal	1:1	1	50	132572/1770	24.00	23.54	0.263	0.024	1.11	0.292	38
Front Side	Normal	1:1	1	50	132572/1770	24.00	23.54	0.216	0.020	1.11	0.240	/
Back Side	Normal	1:1	50%	25	132322/1745	23.00	22.81	0.192	0.070	1.04	0.201	/
Front Side	Normal	1:1	50%	25	132322/1745	23.00	22.81	0.246	0.110	1.04	0.257	/
Hotspot SAR(QPSK, Distance 10mm)												
Back Side	Level 6	1:1	1	99	132072/1720	23.50	23.19	0.381	0.190	1.07	0.409	39
Front Side	Level 6	1:1	1	99	132072/1720	23.50	23.19	0.294	0.040	1.07	0.316	/
Left Edge	Level 6	1:1	1	99	132072/1720	23.50	23.19	0.134	0.035	1.07	0.144	/
Right Edge	Level 6	1:1	1	99	132072/1720	23.50	23.19	0.321	0.024	1.07	0.345	/
Top Edge	N/A	N/A	N/A	N/A	N/A	N/A	N/A	N/A	N/A	N/A	N/A	N/A
Bottom Edge	Level 6	1:1	1	99	132072/1720	23.50	23.19	0.205	0.140	1.07	0.220	/
Back Side	Level 6	1:1	50%	0	132572/1770	22.50	22.24	0.309	0.020	1.06	0.328	/
Front Side	Level 6	1:1	50%	0	132572/1770	22.50	22.24	0.250	0.120	1.06	0.265	/
Left Edge	Level 6	1:1	50%	0	132572/1770	22.50	22.24	0.111	0.030	1.06	0.118	/
Right Edge	Level 6	1:1	50%	0	132572/1770	22.50	22.24	0.267	0.190	1.06	0.283	/
Top Edge	N/A	N/A	N/A	N/A	N/A	N/A	N/A	N/A	N/A	N/A	N/A	N/A
Bottom Edge	Level 6	1:1	50%	0	132572/1770	22.50	22.24	0.147	0.080	1.06	0.156	/
Note: 1. The value with blue color is the maximum SAR Value of each test band.												
2. For QPSK with 100% RB allocation, SAR is required when and the highest reported SAR for 1 RB and 50% RB allocation in are \geq 50% limit(1g).												



Table 11: NR n2 (20MHz, Antenna 7)

Test Position	Power Reduction	RB allocation	RB offset	Channel/Frequency (MHz)	Tune-up (dBm)	Measured power (dBm)	Limit of SAR 1.6 W/kg (mW/g)				Plot No.
							Measured SAR1g	Power Drift (dB)	Scaling Factor	Report SAR1g	
Head SAR (DFT-sOFDM QPSK 15KHz)											
Left Cheek	Normal	1	1	376000/1880	25.00	23.89	0.178	-0.030	1.29	0.230	/
Left Tilt	Normal	1	1	376000/1880	25.00	23.89	0.193	0.023	1.29	0.249	/
Right Cheek	Normal	1	1	376000/1880	25.00	23.89	0.256	0.020	1.29	0.331	/
Right Tilt	Normal	1	1	376000/1880	25.00	23.89	0.213	-0.031	1.29	0.275	/
Left Cheek	Normal	50%	28	376000/1880	24.00	23.88	0.273	0.037	1.03	0.281	40
Left Tilt	Normal	50%	28	376000/1880	24.00	23.88	0.201	0.040	1.03	0.207	/
Right Cheek	Normal	50%	28	376000/1880	24.00	23.88	0.191	0.110	1.03	0.196	/
Right Tilt	Normal	50%	28	376000/1880	24.00	23.88	0.119	0.010	1.03	0.122	/
Head SAR (CP-OFDM QPSK 15KHz)											
Left Cheek	Normal	1	1	376000/1880	23.00	22.02	0.126	0.029	1.25	0.158	/
Body-worn SAR (DFT-sOFDM QPSK 15KHz, Distance 15mm)											
Back Side	Normal	1	1	376000/1880	25.00	23.89	0.328	-0.170	1.29	0.424	41
Front Side	Normal	1	1	376000/1880	25.00	23.89	0.315	0.000	1.29	0.407	/
Back Side	Normal	50%	28	376000/1880	24.00	23.88	0.302	0.020	1.03	0.310	/
Front Side	Normal	50%	28	376000/1880	24.00	23.88	0.217	-0.040	1.03	0.223	/
Body-worn SAR (CP-OFDM QPSK 15KHz, Distance 15mm)											
Back Side	Normal	1	1	376000/1880	23.00	22.02	0.195	0.035	1.25	0.244	/
Hotspot SAR (DFT-sOFDM QPSK 15KHz, Distance 10mm)											
Back Side	Normal	1	1	376000/1880	25.00	23.89	0.533	0.040	1.29	0.688	/
Front Side	Normal	1	1	376000/1880	25.00	23.89	0.491	-0.048	1.29	0.634	/
Left Edge	Normal	1	1	376000/1880	25.00	23.89	0.159	0.038	1.29	0.205	/
Right Edge	Normal	1	1	376000/1880	25.00	23.89	0.420	0.100	1.29	0.542	/
Top Edge	N/A	N/A	N/A	N/A	N/A	N/A	N/A	N/A	N/A	N/A	N/A
Bottom Edge	Normal	1	1	376000/1880	25.00	23.89	0.215	0.140	1.29	0.278	/
Back Side	Normal	50%	28	376000/1880	24.00	23.88	0.508	0.150	1.03	0.522	/
Front Side	Normal	50%	28	376000/1880	24.00	23.88	0.511	0.110	1.03	0.525	/
Left Edge	Normal	50%	28	376000/1880	24.00	23.88	0.078	0.000	1.03	0.080	/
Right Edge	Normal	50%	28	376000/1880	24.00	23.88	0.566	0.020	1.03	0.582	42
Top Edge	N/A	N/A	N/A	N/A	N/A	N/A	N/A	N/A	N/A	N/A	N/A
Bottom Edge	Normal	50%	28	376000/1880	24.00	23.88	0.244	-0.100	1.03	0.251	/
Hotspot SAR (CP-OFDM QPSK 15KHz, Distance 10mm)											
Right Edge	Normal	1	1	376000/1880	23.00	22.02	0.428	-0.010	1.25	0.536	/

Note: 1. The value with blue color is the maximum SAR Value of each test band.

2. For DFT-sOFDM QPSK with 100% RB allocation, SAR is required when and the highest reported SAR for 1 RB and 50% RB allocation in are $\geq 50\%$ limit(1g).

Table 12: NR n5 (20MHz, Antenna 4)



Test Position	Power Reduction	RB allocation	RB offset	Channel/Frequency (MHz)	Tune-up (dBm)	Measured power (dBm)	Limit of SAR 1.6 W/kg (mW/g)				Plot No.
							Measured SAR1g	Power Drift (dB)	Scaling Factor	Report SAR1g	
Head SAR (DFT-sOFDM QPSK 15KHz)											
Left Cheek	Normal	1	1	166800/834	25.00	23.85	0.815	0.000	1.30	1.062	/
	Normal	1	1	167300/836.5	25.00	23.83	0.807	0.012	1.31	1.057	/
	Normal	1	1	167800/839	25.00	23.59	0.739	0.124	1.38	1.022	/
Left Tilt	Normal	1	1	166800/834	25.00	23.85	0.758	0.010	1.30	0.988	/
	Normal	1	1	167300/836.5	25.00	23.83	0.669	-0.081	1.31	0.876	/
	Normal	1	1	167800/839	25.00	23.59	0.695	0.037	1.38	0.962	/
Right Cheek	Normal	1	1	166800/834	25.00	23.85	1.030	0.000	1.30	1.342	/
	Normal	1	1	167300/836.5	25.00	23.83	0.943	0.025	1.31	1.235	/
	Normal	1	1	167800/839	25.00	23.59	0.976	-0.130	1.38	1.350	/
Right Tilt	Normal	1	1	166800/834	25.00	23.85	0.985	0.021	1.30	1.284	/
	Normal	1	1	167300/836.5	25.00	23.83	1.020	0.031	1.31	1.335	/
	Normal	1	1	167800/839	25.00	23.59	0.950	0.121	1.38	1.314	/
Left Cheek	Normal	50%	28	166800/834	24.00	23.83	0.742	-0.010	1.04	0.772	/
Left Tilt	Normal	50%	28	166800/834	24.00	23.83	0.681	-0.030	1.04	0.708	/
Right Cheek	Normal	50%	28	166800/834	24.00	23.83	0.992	-0.090	1.04	1.032	/
	Normal	50%	0	167300/836.5	24.00	23.80	0.982	0.010	1.05	1.028	/
	Normal	50%	56	167800/839	24.00	23.72	1.014	0.036	1.07	1.082	/
Right Tilt	Normal	50%	28	166800/834	24.00	23.83	1.010	0.034	1.04	1.050	/
	Normal	50%	0	167300/836.5	24.00	23.80	0.998	0.023	1.05	1.045	/
	Normal	50%	56	167800/839	24.00	23.72	0.913	0.054	1.07	0.974	/
Right Cheek	Normal	100%	0	166800/834	24.00	23.73	1.060	0.000	1.06	1.128	43
	Normal	100%	0	167300/836.5	24.00	23.71	0.985	0.034	1.07	1.053	/
	Normal	100%	0	167800/839	24.00	23.70	0.967	-0.010	1.07	1.036	/
Right Cheek repeated	Normal	100%	1	167800/839	25.00	23.59	0.972	0.024	1.38	1.345	/
Left Cheek	level1	1	1	166800/834	24.50	22.96	0.649	-0.065	1.43	0.925	/
	level1	1	1	167300/836.5	24.50	23.19	0.705	0.011	1.35	0.953	/
	level1	1	1	167800/839	24.50	22.98	0.662	0.022	1.42	0.939	/
Left Tilt	level1	1	1	167300/836.5	24.50	23.19	0.538	-0.060	1.35	0.727	/
Right Cheek	level1	1	1	166800/834	24.50	22.96	0.852	-0.025	1.43	1.215	/
	level1	1	1	167300/836.5	24.50	23.19	0.960	0.038	1.35	1.298	/
	level1	1	1	167800/839	24.50	22.98	0.816	0.060	1.42	1.158	/
Right Tilt	level1	1	1	166800/834	24.50	22.96	0.741	0.034	1.43	1.056	/
	level1	1	1	167300/836.5	24.50	23.19	0.768	-0.050	1.35	1.038	/
	level1	1	1	167800/839	24.50	22.98	0.852	0.170	1.42	1.209	/
Left Cheek	level1	50%	0	166800/834	23.50	23.20	0.621	0.033	1.07	0.665	/



Left Tilt	level1	50%	0	166800/834	23.50	23.20	0.587	-0.061	1.07	0.629	/
Right Cheek	level1	50%	0	166800/834	23.50	23.20	0.874	0.024	1.07	0.937	/
	level1	50%	0	167300/836.5	23.50	23.10	0.825	0.090	1.10	0.905	/
	level1	50%	56	167800/839	23.50	23.11	0.862	-0.072	1.09	0.943	/
Right Tilt	level1	50%	0	166800/834	23.50	23.20	0.911	0.040	1.07	0.976	/
	level1	50%	0	167300/836.5	23.50	23.10	0.834	0.038	1.10	0.914	/
	level1	50%	56	167800/839	23.50	23.11	0.862	0.070	1.09	0.943	/
Head SAR (CP-OFDM QPSK 15KHz)											
Right Cheek	Normal	1	1	167300/836.5	23.00	22.25	0.874	-0.020	1.19	1.039	/
Body-worn SAR (DFT-sOFDM QPSK 15KHz, Distance 15mm)											
Back Side	Normal	1	1	166800/834	25.00	23.85	0.284	-0.120	1.30	0.370	/
Front Side	Normal	1	1	166800/834	25.00	23.85	0.269	0.190	1.30	0.351	/
Back Side	Normal	50%	28	166800/834	24.00	23.83	0.452	-0.030	1.04	0.470	44
Front Side	Normal	50%	28	166800/834	24.00	23.83	0.326	0.100	1.04	0.339	/
Body-worn SAR (CP-OFDM QPSK 15KHz, Distance 15mm)											
Back Side	Normal	1	1	167300/836.5	23.00	22.25	0.319	0.090	1.19	0.379	/
Hotspot SAR (DFT-sOFDM QPSK 15KHz, Distance 10mm)											
Back Side	Normal	1	1	166800/834	25.00	23.85	0.584	-0.024	1.30	0.761	45
Front Side	Normal	1	1	166800/834	25.00	23.85	0.425	0.120	1.30	0.554	/
Left Edge	Normal	1	1	166800/834	25.00	23.85	0.312	0.036	1.30	0.407	/
Right Edge	Normal	1	1	166800/834	25.00	23.85	0.149	0.090	1.30	0.194	/
Top Edge	Normal	1	1	166800/834	25.00	23.85	0.235	0.060	1.30	0.306	/
Bottom Edge	N/A	N/A	N/A	N/A	N/A	N/A	N/A	N/A	N/A	N/A	N/A
Back Side	Normal	50%	28	166800/834	24.00	23.83	0.274	0.020	1.04	0.285	/
Front Side	Normal	50%	28	166800/834	24.00	23.83	0.491	0.040	1.04	0.511	/
Left Edge	Normal	50%	28	166800/834	24.00	23.83	0.274	0.020	1.04	0.285	/
Right Edge	Normal	50%	28	166800/834	24.00	23.83	0.156	-0.020	1.04	0.162	/
Top Edge	Normal	50%	28	166800/834	24.00	23.83	0.293	0.110	1.04	0.305	/
Bottom Edge	N/A	N/A	N/A	N/A	N/A	N/A	N/A	N/A	N/A	N/A	N/A
Hotspot SAR (CP-OFDM QPSK 15KHz, Distance 10mm)											
Back Side	Normal	1	1	167300/836.5	23.00	22.25	0.374	0.082	1.19	0.444	/

Note: 1. The value with blue color is the maximum SAR Value of each test band.

2. For DFT-sOFDM QPSK with 100% RB allocation, SAR is required when and the highest reported SAR for 1 RB and 50% RB allocation in are \geq 50% limit(1g).

Measurement Variability				
Test Position	Channel/ Frequency(MHz)	MAX Measured SAR _{1g} (W/kg)	1 st Repeated SAR _{1g} (W/kg)	Ratio
Head SAR				
Right Cheek	166800/834	1.060	0.972	1.09

Note: 1) A second repeated measurement was performed only if the ratio of largest to smallest SAR for the original and first repeated



measurements was > 1.20 or when the original or repeated measurement was ≥ 1.45 W/kg ($\sim 10\%$ from the 1-g SAR limit).

2) A third repeated measurement was performed only if the original, first or second repeated measurement was ≥ 1.5 W/kg and the ratio of largest to smallest SAR for the original, first and second repeated measurements is > 1.20 .



Table 13: NR n66 (20MHz, Antenna 7)

Test Position	Power Reduction	RB allocation	RB offset	Channel/Frequency (MHz)	Tune-up (dBm)	Measured power (dBm)	Limit of SAR 1.6 W/kg (mW/g)				Plot No.
							Measured SAR1g	Power Drift (dB)	Scaling Factor	Report SAR1g	
Head SAR (DFT-sOFDM QPSK 30KHz)											
Left Cheek	Normal	1	1	354000/1770	25.00	23.87	0.204	0.026	1.30	0.265	/
Left Tilt	Normal	1	1	354000/1770	25.00	23.87	0.116	0.090	1.30	0.150	/
Right Cheek	Normal	1	1	354000/1770	25.00	23.87	0.244	0.036	1.30	0.317	46
Right Tilt	Normal	1	1	354000/1770	25.00	23.87	0.115	0.190	1.30	0.149	/
Left Cheek	Normal	50%	28	354000/1770	24.00	23.85	0.149	0.150	1.04	0.154	/
Left Tilt	Normal	50%	28	354000/1770	24.00	23.85	0.103	0.170	1.04	0.107	/
Right Cheek	Normal	50%	28	354000/1770	24.00	23.85	0.198	0.120	1.04	0.205	/
Right Tilt	Normal	50%	28	354000/1770	24.00	23.85	0.101	0.110	1.04	0.105	/
Head SAR (CP-OFDM QPSK 15KHz)											
Right Cheek	Normal	1	1	354000/1770	23.00	22.19	0.163	0.071	1.21	0.196	/
Body-worn SAR (DFT-sOFDM QPSK 30KHz, Distance 15mm)											
Back Side	Normal	1	1	354000/1770	25.00	23.87	0.372	0.070	1.30	0.483	/
Front Side	Normal	1	1	354000/1770	25.00	23.87	0.380	-0.010	1.30	0.493	47
Back Side	Normal	50%	28	354000/1770	24.00	23.85	0.233	0.020	1.04	0.241	/
Front Side	Normal	50%	28	354000/1770	24.00	23.85	0.234	0.030	1.04	0.242	/
Body-worn SAR (CP-OFDM QPSK 15KHz, Distance 15mm)											
Front Side	Normal	1	1	354000/1770	23.00	22.19	0.179	0.064	1.21	0.216	/
Hotspot SAR (DFT-sOFDM QPSK 30KHz, Distance 10mm)											
Back Side	Normal	1	1	354000/1770	25.00	23.87	0.550	0.140	1.30	0.713	/
Front Side	Normal	1	1	344000/1720	25.00	23.74	0.572	-0.020	1.34	0.765	/
	Normal	1	1	349000/1745	25.00	23.68	0.625	0.042	1.36	0.847	/
	Normal	1	1	354000/1770	25.00	23.87	0.655	0.040	1.30	0.850	/
Left Edge	Normal	1	1	354000/1770	25.00	23.87	0.192	0.029	1.30	0.249	/
Right Edge	Normal	1	1	354000/1770	25.00	23.87	0.560	0.020	1.30	0.726	/
Top Edge	N/A	N/A	N/A	N/A	N/A	N/A	N/A	N/A	N/A	N/A	N/A
Bottom Edge	Normal	1	1	354000/1770	25.00	23.87	0.254	-0.020	1.30	0.329	/
Back Side	Normal	50%	28	354000/1770	24.00	23.85	0.416	-0.030	1.04	0.431	/
Front Side	Normal	50%	28	354000/1770	24.00	23.85	0.400	0.028	1.04	0.414	/
Left Edge	Normal	50%	28	354000/1770	24.00	23.85	0.044	-0.026	1.04	0.045	/
Right Edge	Normal	50%	28	354000/1770	24.00	23.85	0.699	0.130	1.04	0.724	48
Top Edge	N/A	N/A	N/A	N/A	N/A	N/A	N/A	N/A	N/A	N/A	N/A
Bottom Edge	Normal	50%	28	354000/1770	24.00	23.85	0.208	0.100	1.04	0.215	/
Front Side repeat	Normal	1	1	354000/1770	25.00	23.87	0.651	-0.090	1.30	0.844	/
Hotspot SAR (CP-OFDM QPSK 15KHz, Distance 10mm)											



Right Edge	Normal	1	1	354000/1770	23.00	22.19	0.465	0.180	1.21	0.560	/
<p>Note: 1. The value with blue color is the maximum SAR Value of each test band.</p> <p>2. For DFT-sOFDM QPSK with 100% RB allocation, SAR is required when and the highest reported SAR for 1 RB and 50% RB allocation in are \geq 50% limit(1g).</p>											

Measurement Variability				
Test Position	Channel/ Frequency(MHz)	MAX Measured SAR _{1g} (W/kg)	1 st Repeated SAR _{1g} (W/kg)	Ratio
Hotspot SAR				
Front Side	354000/1770	0.655	0.651	1.09
<p>Note: 1) A second repeated measurement was performed only if the ratio of largest to smallest SAR for the original and first repeated measurements was > 1.20 or when the original or repeated measurement was ≥ 1.45 W/kg (~ 10% from the 1-g SAR limit).</p> <p>2) A third repeated measurement was performed only if the original, first or second repeated measurement was ≥ 1.5 W/kg and the ratio of largest to smallest SAR for the original, first and second repeated measurements is > 1.20.</p>				



Table 14: Wi-Fi (2.4G)

Test Position	Power Reduction	Mode 802.11b	Duty Cycle	Channel/Frequency (MHz)	Tune-up (dBm)	Measured power (dBm)	Limit of SAR 1.6 W/kg (mW/g)				Plot No.
							Measured SAR1g	Power Drift (dB)	Scaling Factor	Report SAR 1g	
Head SAR											
Left Cheek	Normal	DSSS	99.0%	1/2412	22.00	20.86	0.600	0.010	1.31	0.788	/
	Normal	DSSS	99.0%	6/2437	22.00	20.91	0.685	0.030	1.30	0.889	49
	Normal	DSSS	99.0%	11/2462	22.00	20.75	0.582	0.010	1.35	0.784	/
Left Tilt	Normal	DSSS	99.0%	6/2437	22.00	20.91	0.286	0.080	1.30	0.371	/
Right Cheek	Normal	DSSS	99.0%	6/2437	22.00	20.91	0.256	0.034	1.30	0.332	/
Right Tilt	Normal	DSSS	99.0%	6/2437	22.00	20.91	0.213	0.130	1.30	0.277	/
Left Cheek repeated	Normal	DSSS	99.0%	6/2437	22.00	20.91	0.679	-0.052	1.30	0.882	/
Left Cheek	Level 1	DSSS	99.0%	6/2437	19.00	18.33	0.299	-0.134	1.18	0.352	/
Left Tilt	Level 1	DSSS	99.0%	6/2437	19.00	18.33	0.130	0.055	1.18	0.153	/
Right Cheek	Level 1	DSSS	99.0%	6/2437	19.00	18.33	0.087	0.024	1.18	0.102	/
Right Tilt	Level 1	DSSS	99.0%	6/2437	19.00	18.33	0.105	0.022	1.18	0.124	/
Body-worn SAR (Distance 15mm)											
Back Side	Normal	DSSS	99.0%	6/2437	22.00	20.91	0.163	-0.010	1.30	0.212	50
Front Side	Normal	DSSS	99.0%	6/2437	22.00	20.91	0.084	0.134	1.30	0.109	/
Back Side	Level 2	DSSS	99.0%	6/2437	19.00	18.33	0.081	-0.072	1.18	0.096	/
Front Side	Level 2	DSSS	99.0%	6/2437	19.00	18.33	0.046	-0.141	1.18	0.054	/
Hotspot SAR(Distance 10mm)											
Back Side	Normal	DSSS	99.0%	6/2437	22.00	20.91	0.307	0.088	1.30	0.399	51
Front Side	Normal	DSSS	99.0%	6/2437	22.00	20.91	0.176	-0.030	1.30	0.228	/
Left Edge	N/A	N/A	N/A	N/A	N/A	N/A	N/A	N/A	N/A	N/A	N/A
Right Edge	Normal	DSSS	99.0%	6/2437	22.00	20.91	0.249	-0.180	1.30	0.323	/
Top Edge	Normal	DSSS	99.0%	6/2437	22.00	20.91	0.129	0.077	1.30	0.167	/
Bottom Edge	N/A	N/A	N/A	N/A	N/A	N/A	N/A	N/A	N/A	N/A	N/A
Back Side	Level 3	DSSS	99.0%	6/2437	19.00	18.33	0.181	-0.099	1.18	0.213	/
Front Side	Level 3	DSSS	99.0%	6/2437	19.00	18.33	0.085	-0.029	1.18	0.100	/
Left Edge	N/A	N/A	N/A	N/A	N/A	N/A	N/A	N/A	N/A	N/A	N/A
Right Edge	Level 3	DSSS	99.0%	6/2437	19.00	18.33	0.118	0.070	1.18	0.139	/
Top Edge	Level 3	DSSS	99.0%	6/2437	19.00	18.33	0.057	-0.160	1.18	0.068	/
Bottom Edge	N/A	N/A	N/A	N/A	N/A	N/A	N/A	N/A	N/A	N/A	N/A

Note: 1. The value with blue color is the maximum SAR Value of each test band.



Measurement Variability				
Test Position	Channel/ Frequency(MHz)	MAX Measured SAR _{1g} (W/kg)	1 st Repeated SAR _{1g} (W/kg)	Ratio
Head SAR				
Left Cheek	6/2437	0.685	0.679	1.01
Note: 1) A second repeated measurement was performed only if the ratio of largest to smallest SAR for the original and first repeated measurements was > 1.20 or when the original or repeated measurement was ≥ 1.45 W/kg (~ 10% from the 1-g SAR limit). 2) A third repeated measurement was performed only if the original, first or second repeated measurement was ≥ 1.5 W/kg and the ratio of largest to smallest SAR for the original, first and second repeated measurements is > 1.20.				

MAX Adjusted SAR								
Mode	Test Position	Power Reduction	Channel/ Frequency (MHz)	MAX Reported SAR _{1g} (W/kg)	802.11b Tune-up limit (dBm)	Tune-up limit (dBm)	Scaling Factor	Adjusted SAR _{1g} (W/kg)
802.11g	Left Cheek	Normal	6/2437	0.889	22.00	21.00	0.80	0.713
802.11n HT20	Left Cheek	Normal	6/2437	0.889	22.00	21.00	0.80	0.713
802.11n HT40	Left Cheek	Normal	6/2437	0.889	22.00	20.50	0.72	0.636
802.11g	Left Cheek	Level 1&2&3	6/2437	0.352	19.00	18.00	0.80	0.282
802.11n HT20	Left Cheek	Level 1&2&3	6/2437	0.352	19.00	18.00	0.80	0.282
802.11n HT40	Left Cheek	Level 1&2&3	6/2437	0.352	19.00	17.50	0.72	0.252
Note: SAR is not required for OFDM when the highest reported SAR for DSSS is adjusted by the ratio of OFDM to DSSS specified maximum output power and the adjusted SAR is ≤ 1.2 W/kg.								



Table 15: Wi-Fi (5G,U-NII-1)

Test Position	Power Reduction	Mode 802.11a	Duty Cycle	Channel/Frequency (MHz)	Tune-up dBm)	Measured power (dBm)	Limit of SAR 1.6 W/kg (mW/g)				Plot No.
							Measured SAR1g	Power Drift (dB)	Scaling Factor	Report SAR 1g	
Head SAR											
Left Cheek	Normal	OFDM	98.0%	36/5180	22.00	21.50	0.557	-0.040	1.14	0.638	52
Left Tilt	Normal	OFDM	98.0%	36/5180	22.00	21.50	0.139	0.038	1.14	0.159	/
Right Cheek	Normal	OFDM	98.0%	36/5180	22.00	21.50	0.138	0.035	1.14	0.158	/
Right Tilt	Normal	OFDM	98.0%	36/5180	22.00	21.50	0.121	0.041	1.14	0.139	/
Left Cheek	Level 1	OFDM	98.0%	36/5180	19.00	17.88	0.348	-0.034	1.32	0.460	/
Left Tilt	Level 1	OFDM	98.0%	36/5180	19.00	17.88	0.097	0.049	1.32	0.128	/
Right Cheek	Level 1	OFDM	98.0%	36/5180	19.00	17.88	0.080	0.107	1.32	0.106	/
Right Tilt	Level 1	OFDM	98.0%	36/5180	19.00	17.88	0.057	0.084	1.32	0.075	/
Body-worn SAR (Distance 15mm)											
Back Side	Normal	OFDM	98.0%	36/5180	22.00	21.50	0.382	0.180	1.14	0.437	53
Front Side	Normal	OFDM	98.0%	36/5180	22.00	21.50	0.300	0.046	1.14	0.343	/
Back Side	Level 2	OFDM	98.0%	36/5180	19.00	17.88	0.173	-0.125	1.32	0.228	/
Front Side	Level 2	OFDM	98.0%	36/5180	19.00	17.88	0.148	0.010	1.32	0.195	/
Hotspot SAR(Distance 10mm)											
Back Side	Normal	OFDM	98.0%	36/5180	22.00	21.50	0.600	0.030	1.14	0.687	/
Front Side	Normal	OFDM	98.0%	36/5180	22.00	21.50	0.450	0.120	1.14	0.515	/
Left Edge	N/A	N/A	N/A	N/A	N/A	N/A	N/A	N/A	N/A	N/A	N/A
Right Edge	Normal	OFDM	98.0%	36/5180	22.00	21.50	1.040	-0.023	1.14	1.191	54
	Normal	OFDM	98.0%	40/5200	22.00	21.36	1.010	-0.070	1.18	1.194	/
	Normal	OFDM	98.0%	44/5220	22.00	21.32	0.948	-0.035	1.19	1.131	/
Top Edge	Normal	OFDM	98.0%	36/5180	22.00	21.50	0.071	0.024	1.14	0.081	/
Bottom Edge	N/A	N/A	N/A	N/A	N/A	N/A	N/A	N/A	N/A	N/A	N/A
Right Edge repeated	Normal	OFDM	98.0%	40/5200	22.00	21.36	0.997	-0.090	1.18	1.179	/
Back Side	Level 3	OFDM	98.0%	36/5180	19.00	17.88	0.253	-0.124	1.32	0.334	/
Front Side	Level 3	OFDM	98.0%	36/5180	19.00	17.88	0.212	-0.013	1.32	0.280	/
Right Edge	Level 3	OFDM	98.0%	36/5180	19.00	17.88	0.351	-0.023	1.32	0.464	/
Top Edge	Level 3	OFDM	98.0%	36/5180	19.00	17.88	0.030	-0.050	1.32	0.040	/
Note: 1. The value with blue color is the maximum SAR Value of each test band.											



Table 16: Wi-Fi (5G,U-NII-3)

Test Position	Power Reduction	Mode 802.11a	Duty Cycle	Channel/Frequency (MHz)	Tune-up dBm)	Measured power (dBm)	Limit of SAR 1.6 W/kg (mW/g)				Plot No.
							Measured SAR1g	Power Drift (dB)	Scaling Factor	Report SAR 1g	
Head SAR											
Left Cheek	Normal	OFDM	98.0%	165/5825	22.00	21.38	0.236	0.044	1.18	0.278	55
Left Tilt	Normal	OFDM	98.0%	165/5825	22.00	21.38	0.202	-0.100	1.18	0.238	/
Right Cheek	Normal	OFDM	98.0%	165/5825	22.00	21.38	0.141	0.057	1.18	0.166	/
Right Tilt	Normal	OFDM	98.0%	165/5825	22.00	21.38	0.131	0.079	1.18	0.154	/
Body-worn SAR (Distance 15mm)											
Back Side	Normal	OFDM	98.0%	165/5825	22.00	21.38	0.246	0.025	1.18	0.290	56
Front Side	Normal	OFDM	98.0%	165/5825	22.00	21.38	0.086	-0.113	1.18	0.102	/
Hotspot SAR(Distance 10mm)											
Back Side	Normal	OFDM	98.0%	165/5825	22.00	21.38	0.299	0.060	1.18	0.352	/
Front Side	Normal	OFDM	98.0%	165/5825	22.00	21.38	0.131	0.060	1.18	0.154	/
Left Edge	N/A	N/A	N/A	N/A	N/A	N/A	N/A	N/A	N/A	N/A	N/A
Right Edge	Normal	OFDM	98.0%	165/5825	22.00	21.38	0.532	0.060	1.18	0.626	57
Top Edge	Normal	OFDM	98.0%	165/5825	22.00	21.38	0.066	0.089	1.18	0.077	/
Bottom Edge	N/A	N/A	N/A	N/A	N/A	N/A	N/A	N/A	N/A	N/A	N/A

Note: 1. The value with blue color is the maximum SAR Value of each test band.



Table 17: BT

Test Position	Power Reduction	Mode	Duty Cycle	Channel/Frequency (MHz)	Tune-up (dBm)	Measured power (dBm)	Limit of SAR 1.6 W/kg (mW/g)				Plot No.
							Measured SAR1g	Power Drift (dB)	Scaling Factor	Report SAR 1g	
Head SAR											
Left Cheek	standard	GFSK	77.1%	78/2480	14.50	13.23	0.089	0.069	1.74	0.155	58
Left Tilt	standard	GFSK	77.1%	78/2480	14.50	13.23	0.032	0.164	1.74	0.056	/
Right Cheek	standard	GFSK	77.1%	78/2480	14.50	13.23	0.013	0.060	1.74	0.023	/
Right Tilt	standard	GFSK	77.1%	78/2480	14.50	13.23	0.016	0.085	1.74	0.028	/
Body SAR (Distance 10mm)											
Back Side	standard	GFSK	77.1%	78/2480	14.50	13.23	0.061	0.137	1.74	0.106	59
Front Side	standard	GFSK	77.1%	78/2480	14.50	13.23	0.027	-0.149	1.74	0.047	/
Left Edge	standard	GFSK	77.1%	78/2480	14.50	13.23	0.001	0.000	1.74	0.001	/
Right Edge	standard	GFSK	77.1%	78/2480	14.50	13.23	0.029	0.040	1.74	0.051	/
Top Edge	standard	GFSK	77.1%	78/2480	14.50	13.23	0.015	0.054	1.74	0.026	/
Bottom Edge	N/A	N/A	N/A	N/A	N/A	N/A	N/A	N/A	N/A	N/A	N/A
Test Position	Power Reduction	Mode	Duty Cycle	Channel/Frequency (MHz)	Tune-up (dBm)	Measured power (dBm)	Limit of SAR 4 W/kg (mW/g)				Plot No.
							Measured SAR10g	Power Drift (dB)	Scaling Factor	Report SAR 10g	
Product Specific 10-g SAR (Distance 0mm)											
Back Side	standard	GFSK	77.1%	78/2480	14.50	13.23	0.537	-0.025	1.74	0.410	60
Front Side	standard	GFSK	77.1%	78/2480	14.50	13.23	0.268	-0.032	1.74	0.193	/
Left Edge	standard	GFSK	77.1%	78/2480	14.50	13.23	0.023	-0.034	1.74	0.021	/
Right Edge	standard	GFSK	77.1%	78/2480	14.50	13.23	0.284	0.021	1.74	0.203	/
Top Edge	standard	GFSK	77.1%	78/2480	14.50	13.23	0.155	-0.066	1.74	0.141	/
Bottom Edge	N/A	N/A	N/A	N/A	N/A	N/A	N/A	N/A	N/A	N/A	N/A

Note: 1. The value with blue color is the maximum SAR Value of each test band.

10.3 Simultaneous Transmission Analysis

Simultaneous Transmission Configurations	Head	Body-worn	Hotspot	Product Specific 10-g SAR
LTE + Bluetooth	Yes	Yes	NA	Yes
LTE + Wi-Fi-2.4GHz	Yes	Yes	Yes	Yes
LTE + Wi-Fi-5GHz	Yes	Yes	Yes	Yes
EN-DC + Bluetooth	Yes	Yes	NA	Yes
EN-DC + Wi-Fi-2.4GHz	Yes	Yes	Yes	Yes
EN-DC + Wi-Fi-5GHz	Yes	Yes	Yes	Yes
Wi-Fi-2.4GHz + Bluetooth	Yes	Yes	Yes	Yes
Wi-Fi-5GHz + Bluetooth	Yes	Yes	Yes	Yes

General Note:

1. The Scaled SAR summation is calculated based on the same configuration and test position.
2. Per KDB 447498 D01, simultaneous transmission SAR is compliant if,
 - i) Scalar SAR summation < 1.6W/kg, simultaneously transmission SAR measurement is not necessary.
 - ii) $SPLSR = (SAR1 + SAR2)^{1.5} / (\text{min. separation distance, mm})$, and the peak separation distance is determined from the square root of $[(x1-x2)^2 + (y1-y2)^2 + (z1-z2)^2]$, where (x1, y1, z1) and (x2, y2, z2) are the coordinates of the extrapolated peak SAR locations in the zoom scan.
 - iii) If $SPLSR \leq 0.04$, simultaneously transmission SAR measurement is not necessary.
- 2: Base on EN-DC DPS function, the EN-DC worse case SAR value falls on LTE band or NR band, only selected highest SAR to evaluation the simulation simultaneous transmission.



The maximum SAR_{1g} Value for Main-Antenna

Test Position		SAR _{1g} (W/kg)	EN-DC_5A_n2			EN-DC_13A_n2			EN-DC_66A_n2			EN-DC MAX. SAR _{1g}
			n2	LTE 5	EN-DC_5A_n2	n2	LTE 13	EN-DC_13A_n2	n2	LTE 66	EN-DC_66A_n2	
Head	Left Cheek	0.281	0.740	0.740	0.281	0.379	0.379	0.281	0.064	0.281	0.740	
	Left Tilt	0.249	0.586	0.586	0.249	0.439	0.439	0.249	0.033	0.249	0.586	
	Right Cheek	0.331	1.051	1.051	0.331	0.876	0.876	0.331	0.054	0.331	1.051	
	Right Tilt	0.275	1.154	1.154	0.275	0.723	0.723	0.275	0.034	0.275	1.154	
Body worn	Back Side	0.424	0.565	0.565	0.424	0.590	0.590	0.424	0.859	0.859	0.859	
	Front Side	0.407	0.415	0.415	0.407	0.235	0.407	0.407	0.434	0.434	0.434	
Hotspot	Back Side	0.688	0.671	0.688	0.688	0.648	0.688	0.688	0.512	0.688	0.688	
	Front Side	0.634	0.641	0.641	0.634	0.361	0.634	0.634	0.423	0.634	0.641	
	Left Edge	0.205	0.496	0.496	0.205	0.218	0.218	0.205	0.046	0.205	0.496	
	Right Edge	0.582	0.290	0.582	0.582	0.142	0.582	0.582	0.045	0.582	0.582	
	Top Edge	N/A	0.519	0.519	N/A	0.259	0.259	N/A	N/A	0.000	0.519	
	Bottom Edge	0.278	N/A	0.278	0.278	N/A	0.278	0.278	1.364	1.364	1.364	
Product Specific 10-g SAR	Back Side	N/A	N/A	N/A	N/A	N/A	N/A	N/A	N/A	N/A	N/A	
	Front Side	N/A	N/A	N/A	N/A	N/A	N/A	N/A	N/A	N/A	N/A	
	Left Edge	N/A	N/A	N/A	N/A	N/A	N/A	N/A	N/A	N/A	N/A	
	Right Edge	N/A	N/A	N/A	N/A	N/A	N/A	N/A	N/A	N/A	N/A	
	Top Edge	N/A	N/A	N/A	N/A	N/A	N/A	N/A	N/A	N/A	N/A	
	Bottom Edge	N/A	N/A	N/A	N/A	N/A	N/A	N/A	3.657	3.657	3.657	

Note: Base on EN-DC DPS function, the EN-DC worse case SAR value falls on LTE band or NR band, only selected highest SAR to evaluation the simulation simultaneous transmission.

Test Position		SAR _{1g} (W/kg)	EN-DC_2A_n5			EN-DC_66A_n5			EN-DC MAX. SAR _{1g}
			n5	LTE (EN-DC) Band 2	EN-DC_2A_n5	n5	LTE (EN-DC) Band 66	EN-DC_66A_n5	
Head	Left Cheek	0.953	0.063	0.953	0.953	0.131	0.953	0.953	
	Left Tilt	0.727	0.049	0.727	0.727	0.092	0.727	0.727	
	Right Cheek	1.298	0.068	1.298	1.298	0.137	1.298	1.298	
	Right Tilt	1.209	0.041	1.209	1.209	0.099	1.209	1.209	
Body worn	Back Side	0.470	0.121	0.470	0.470	0.292	0.470	0.470	
	Front Side	0.351	0.125	0.351	0.351	0.257	0.351	0.351	
Hotspot	Back Side	0.761	0.170	0.761	0.761	0.409	0.761	0.761	
	Front Side	0.554	0.168	0.554	0.554	0.316	0.554	0.554	
	Left Edge	0.407	0.051	0.407	0.407	0.144	0.407	0.407	
	Right Edge	0.194	0.106	0.194	0.194	0.345	0.345	0.345	
	Top Edge	0.306	N/A	0.306	0.306	N/A	0.306	0.306	
	Bottom Edge	N/A	0.120	0.120	N/A	0.220	0.220	0.220	



Note: Base on EN-DC DPS function, the EN-DC worse case SAR value falls on LTE band or NR band, only selected highest SAR to evaluation the simulation simultaneous transmission.

SAR _{1g} (W/kg)		EN-DC_2A_n66			EN-DC_5A_n66			EN-DC_13A_n66			EN-DC MAX. SAR _{1g}
		n66	LTE 2	EN-DC_2A_n66	n66	LTE 5	EN-DC_5A_n66	n66	LTE 13	EN-DC_13A_n66	
Head	Left Cheek	0.265	0.092	0.265	0.265	0.740	0.740	0.265	0.379	0.379	0.740
	Left Tilt	0.150	0.040	0.150	0.150	0.586	0.586	0.150	0.439	0.439	0.586
	Right Cheek	0.317	0.050	0.317	0.317	1.051	1.051	0.317	0.876	0.876	1.051
	Right Tilt	0.149	0.055	0.149	0.149	1.154	1.154	0.149	0.723	0.723	1.154
Body worn	Back Side	0.483	1.184	1.184	0.483	0.565	0.565	0.483	0.590	0.590	1.184
	Front Side	0.493	0.409	0.493	0.493	0.415	0.493	0.493	0.235	0.493	0.493
Hotspot	Back Side	0.713	0.799	0.799	0.713	0.671	0.713	0.713	0.648	0.713	0.799
	Front Side	0.850	0.306	0.850	0.850	0.641	0.850	0.850	0.361	0.850	0.850
	Left Edge	0.249	0.020	0.249	0.249	0.496	0.496	0.249	0.218	0.249	0.496
	Right Edge	0.726	0.038	0.726	0.726	0.290	0.726	0.726	0.142	0.726	0.726
	Top Edge	N/A	N/A	0.000	N/A	0.519	0.519	N/A	0.259	0.259	0.519
	Bottom Edge	0.329	1.026	1.026	0.329	N/A	0.329	0.329	N/A	0.329	1.026
Product Specific 10-g SAR	Back Side	N/A	2.514	2.514	N/A	N/A	N/A	N/A	N/A	N/A	2.514
	Front Side	N/A	N/A	N/A	N/A	N/A	N/A	N/A	N/A	N/A	N/A
	Left Edge	N/A	N/A	N/A	N/A	N/A	N/A	N/A	N/A	N/A	N/A
	Right Edge	N/A	N/A	N/A	N/A	N/A	N/A	N/A	N/A	N/A	N/A
	Top Edge	N/A	N/A	N/A	N/A	N/A	N/A	N/A	N/A	N/A	N/A
	Bottom Edge	N/A	1.939	1.939	N/A	N/A	N/A	N/A	N/A	N/A	1.939

Note: Base on EN-DC DPS function, the EN-DC worse case SAR value falls on LTE band or NR band, only selected highest SAR to evaluation the simulation simultaneous transmission.



Test Position		SAR _{1g} (W/kg)	LTE	LTE	LTE	LTE	LTE	LTE	EN-DC			MAX. SAR _{1g}
			FDD 2	FDD 4	FDD 5	FDD 12	FDD 13	FDD 66				
Head	Left Cheek	0.092	0.141	0.740	0.090	0.379	0.064	0.740	0.953	0.740	0.953	
	Left Tilt	0.040	0.040	0.586	0.086	0.439	0.033	0.586	0.727	0.586	0.727	
	Right Cheek	0.050	0.074	1.051	0.168	0.876	0.054	1.051	1.298	1.051	1.298	
	Right Tilt	0.055	0.038	1.154	0.135	0.723	0.034	1.154	1.209	1.154	1.209	
Body worn	Back Side	1.184	0.666	0.565	0.066	0.590	0.859	0.859	0.470	1.184	1.184	
	Front Side	0.409	0.516	0.415	0.022	0.235	0.434	0.434	0.351	0.493	0.516	
Hotspot	Back Side	0.799	0.797	0.671	0.098	0.648	0.512	0.688	0.761	0.799	0.799	
	Front Side	0.306	0.506	0.641	0.061	0.361	0.423	0.641	0.554	0.850	0.850	
	Left Edge	0.020	0.048	0.496	0.001	0.218	0.046	0.496	0.407	0.496	0.496	
	Right Edge	0.038	0.027	0.290	0.001	0.142	0.045	0.582	0.345	0.726	0.726	
	Top Edge	N/A	N/A	0.519	0.001	0.259	N/A	0.519	0.306	0.519	0.519	
	Bottom Edge	1.026	1.107	N/A	N/A	N/A	1.364	1.364	0.220	1.026	1.364	
Product Specific 10-g SAR	Back Side	2.514	1.141	N/A	N/A	N/A	N/A	N/A	N/A	2.514	2.514	
	Front Side	N/A	N/A	N/A	N/A	N/A	N/A	N/A	N/A	N/A	N/A	
	Left Edge	N/A	N/A	N/A	N/A	N/A	N/A	N/A	N/A	N/A	N/A	
	Right Edge	N/A	N/A	N/A	N/A	N/A	N/A	N/A	N/A	N/A	N/A	
	Top Edge	N/A	N/A	N/A	N/A	N/A	N/A	N/A	N/A	N/A	N/A	
	Bottom Edge	1.939	2.557	N/A	N/A	N/A	3.657	3.657	N/A	1.939	3.657	

Test Position		SAR _{1g} (W/kg)	Wi-Fi (U-NII-1)	Wi-Fi (U-NII-3)	Wi-Fi 5G MAX. SAR _{1g}
Head	Left Cheek	0.460	0.460	0.278	0.460
	Left Tilt	0.128	0.128	0.238	0.238
	Right Cheek	0.106	0.106	0.166	0.166
	Right Tilt	0.075	0.075	0.154	0.154
Body worn	Back Side	0.228	0.228	0.290	0.290
	Front Side	0.195	0.195	0.102	0.195
Hotspot	Back Side	0.334	0.334	0.352	0.352
	Front Side	0.280	0.280	0.154	0.280
	Left Edge	N/A	N/A	N/A	N/A
	Right Edge	0.464	0.464	0.626	0.626
	Top Edge	0.040	0.040	0.077	0.077
	Bottom Edge	N/A	N/A	N/A	N/A



SAR _{1g/10g} (W/kg)		MAX. SAR _{1g}	2.4G	Wi-Fi 5G	BT	MAX. ΣSAR _{1g/10g}				
						1	2	3	4	1+2
Head	Left, Cheek	0.953	0.352	0.460	0.155	1.305	1.413	1.108	1.568	0.615
	Left, Tilt	0.727	0.153	0.238	0.056	0.880	0.965	0.783	1.021	0.294
	Right, Cheek	1.298	0.102	0.166	0.023	1.400	1.464	1.321	1.487	0.189
	Right, Tilt	1.209	0.124	0.154	0.028	1.333	1.363	1.237	1.391	0.182
Body worn	Back Side	1.184	0.096	0.290	0.106	1.280	1.474	1.290	1.580	0.396
	Front Side	0.516	0.054	0.195	0.047	0.570	0.711	0.563	0.758	0.242
Hotspot	Back Side	0.799	0.213	0.352	0.106	1.012	1.151	/	1.257	0.458
	Front Side	0.850	0.100	0.280	0.047	0.950	1.130	/	1.177	0.327
	Left Edge	0.496	N/A	N/A	0.001	0.496	0.496	/	0.497	0.001
	Right Edge	0.726	0.139	0.626	0.051	0.865	1.352	/	1.403	0.677
	Top Edge	0.519	0.068	0.077	0.026	0.587	0.596	/	0.622	0.103
	Bottom Edge	1.364	N/A	N/A	N/A	1.364	1.364	/	1.364	0.000
Product Specific 10-g SAR	Back Side	2.514	N/A	N/A	0.410	2.514	2.514	2.924	2.924	0.410
	Front Side	N/A	N/A	N/A	0.193	0.000	0.000	0.193	0.193	0.193
	Left Edge	N/A	N/A	N/A	0.021	0.000	0.000	0.021	0.021	0.021
	Right Edge	N/A	N/A	N/A	0.203	0.000	0.000	0.203	0.203	0.203
	Top Edge	N/A	N/A	N/A	0.141	0.000	0.000	0.141	0.141	0.141
	Bottom Edge	3.657	N/A	N/A	N/A	3.657	3.657	3.657	3.657	0.000

Note: 1.The value with blue color is the maximum ΣSAR_{1g/10g} Value.
 2.MAX. ΣSAR_{1g/10g} =Unlicensed SAR_{MAX} +Licensed SAR_{MAX}

MAX. ΣSAR_{1g} = 1.580 W/kg < 1.6W/kg and MAX. ΣSAR_{10g} = 3.657 W/kg < 4 W/kg, so the Simultaneous transimition SAR with volum scan are not required for Wi-Fi and Main-Antenna.



11 Measurement Uncertainty

Per KDB 865664 D01 SAR Measurement 100 MHz to 6 GHz, when the highest measured 1-g SAR within a frequency band is < 1.5 W/kg, the extensive SAR measurement uncertainty analysis described in IEEE Std 1528- 2013 is not required in SAR reports submitted for equipment approval. This also applies to the 10-g SAR required for phablets in KDB Publication 648474.

ANNEX A: Test Layout



Tissue Simulating Liquids

For the measurement of the field distribution inside the flat phantom with DASY, the phantom must be filled with around 25 liters of homogeneous body tissue simulating liquid. For Head and Body SAR testing, the liquid height from the center of the flat phantom to the liquid top surface is larger than 15 cm, which is shown in Picture 3 and Picture 4.



Picture 3: liquid depth in the head Phantom

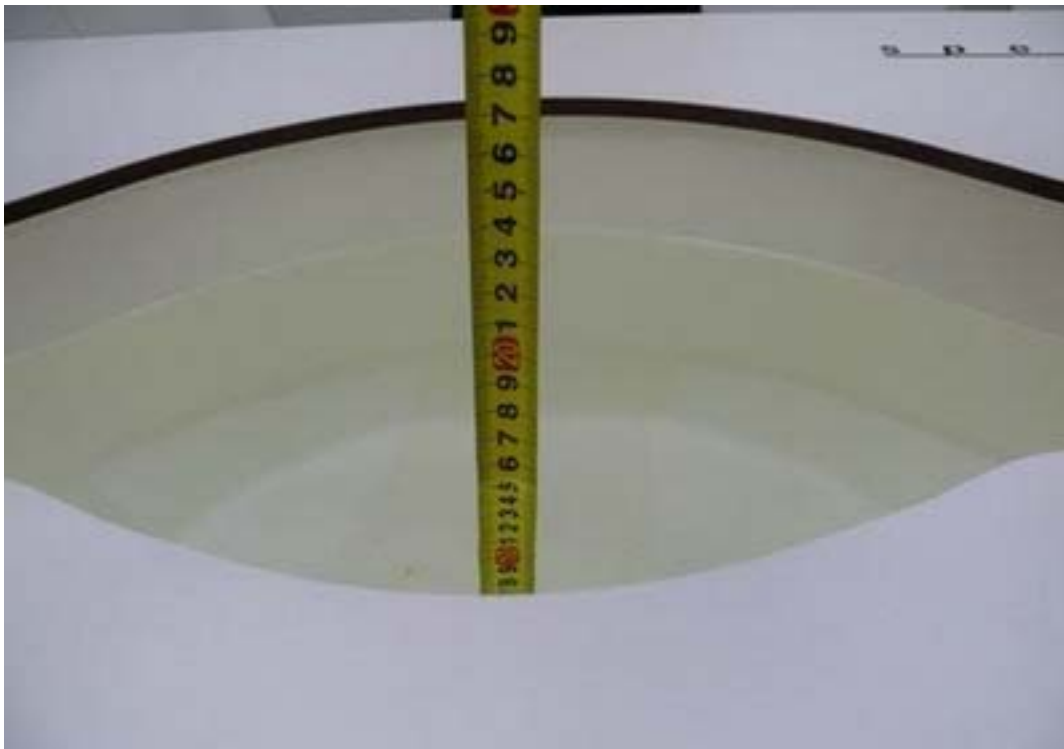

Picture 4: Liquid depth in the flat Phantom

ANNEX B: System Check Results

Plot 1 System Performance Check at 750 MHz TSL

DUT: Dipole 750 MHz; Type: D750V3; Serial: D750V3

Date: 8/25/2020

Communication System: CW (0); Frequency: 750 MHz; Duty Cycle: 1:1

Medium parameters used: $f = 750 \text{ MHz}$; $\sigma = 0.88 \text{ S/m}$; $\epsilon_r = 42.3$; $\rho = 1000 \text{ kg/m}^3$

Ambient Temperature: $22.3 \text{ }^\circ\text{C}$ Liquid Temperature: $21.5 \text{ }^\circ\text{C}$

Phantom section: Flat Section

DASY5 Configuration:

Sensor-Surface: 1.4mm (Mechanical Surface Detection)

Probe: EX3DV4 - SN3677; ConvF(9.78, 9.78, 9.78); Calibrated: 7/6/2020;

Electronics: DAE4 SN1317; Calibrated: 10/23/2019

Phantom: SAM1; Type: SAM; Serial: TP-1534

Measurement SW: DASY52, Version 52.10 (1); SEMCAD X Version 14.6.11 (7439)

d=15mm, Pin=250mW/Area Scan (4x12x1): Measurement grid: dx=15mm, dy=15mm

Maximum value of SAR (measured) = 2.29 W/kg

d=15mm, Pin=250mW/Zoom Scan (5x5x7)/Cube 0: Measurement grid: dx=8mm, dy=8mm, dz=5mm

Reference Value = 50.653 V/m; Power Drift = -0.08 dB

Peak SAR (extrapolated) = 3.16 W/kg

SAR(1 g) = 2.20 W/kg; SAR(10 g) = 1.41 W/kg

Maximum value of SAR (measured) = 2.29 W/kg

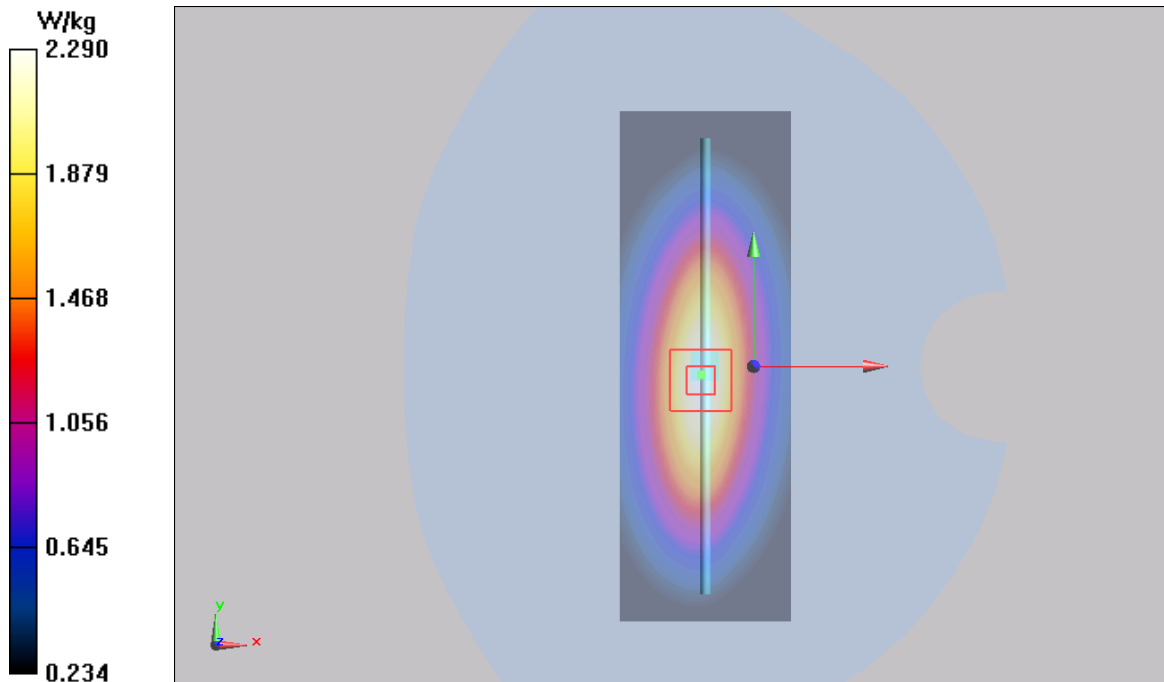

Plot 2 System Performance Check at 835 MHz TSL

DUT: Dipole 835 MHz; Type: D835V2; Serial: D835V2

Date: 10/15/2020

Communication System: CW; Frequency: 835 MHz; Duty Cycle: 1:1

Medium parameters used: $f = 835 \text{ MHz}$; $\sigma = 0.88 \text{ S/m}$; $\epsilon_r = 41.4$; $\rho = 1000 \text{ kg/m}^3$

Ambient Temperature: $22.3 \text{ }^\circ\text{C}$ Liquid Temperature: $21.5 \text{ }^\circ\text{C}$

Phantom section: Flat Section

DASY5 Configuration:

Sensor-Surface: 1.4mm (Mechanical Surface Detection)

Probe: EX3DV4 - SN3677; ConvF(9.38, 9.38, 9.38); Calibrated: 7/6/2020;

Electronics: DAE4 SN1317; Calibrated: 10/23/2019

Phantom: SAM1; Type: SAM; Serial: TP-1534

Measurement SW: DASY52, Version 52.10 (1); SEMCAD X Version 14.6.11 (7439)

d=15mm, Pin=250mW/Area Scan (4x12x1): Measurement grid: dx=15mm, dy=15mm

Maximum value of SAR (measured) = 2.64 mW/g

d=15mm, Pin=250mW/Zoom Scan (5x5x7)/Cube 0: Measurement grid: dx=8mm, dy=8mm, dz=5mm

Reference Value = 54.4 V/m; Power Drift = -0.076 dB

Peak SAR (extrapolated) = 3.67 W/kg

SAR(1 g) = 2.46 mW/g; SAR(10 g) = 1.6 mW/g

Maximum value of SAR (measured) = 2.64 mW/g

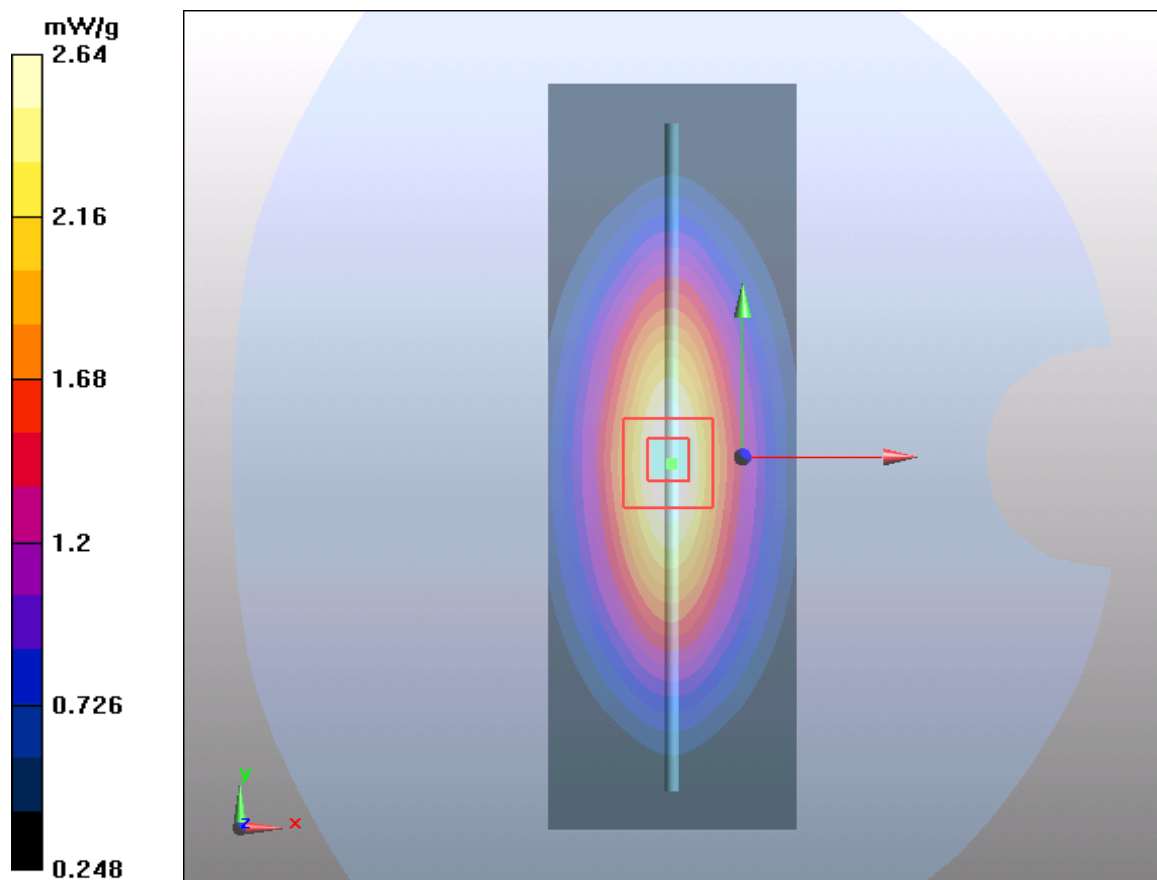

Plot 3 System Performance Check at 835 MHz TSL

DUT: Dipole 835 MHz; Type: D835V2; Serial: D835V2

Date: 10/16/2020

Communication System: CW; Frequency: 835 MHz; Duty Cycle: 1:1

Medium parameters used: $f = 835 \text{ MHz}$; $\sigma = 0.87 \text{ S/m}$; $\epsilon_r = 41.3$; $\rho = 1000 \text{ kg/m}^3$

Ambient Temperature: $22.3 \text{ }^\circ\text{C}$ Liquid Temperature: $21.5 \text{ }^\circ\text{C}$

Phantom section: Flat Section

DASY5 Configuration:

Sensor-Surface: 1.4mm (Mechanical Surface Detection)

Probe: EX3DV4 - SN3677; ConvF(9.38, 9.38, 9.38); Calibrated: 7/6/2020;

Electronics: DAE4 SN1317; Calibrated: 10/23/2019

Phantom: SAM1; Type: SAM; Serial: TP-1534

Measurement SW: DASY52, Version 52.10 (1); SEMCAD X Version 14.6.11 (7439)

d=15mm, Pin=250mW/Area Scan (4x12x1): Measurement grid: dx=15mm, dy=15mm

Maximum value of SAR (measured) = 2.59 mW/g

d=15mm, Pin=250mW/Zoom Scan (5x5x7)/Cube 0: Measurement grid: dx=8mm, dy=8mm, dz=5mm

Reference Value = 54.3 V/m; Power Drift = -0.06 dB

Peak SAR (extrapolated) = 3.67 W/kg

SAR(1 g) = 2.45 mW/g; SAR(10 g) = 1.65 mW/g

Maximum value of SAR (measured) = 2.70 mW/g

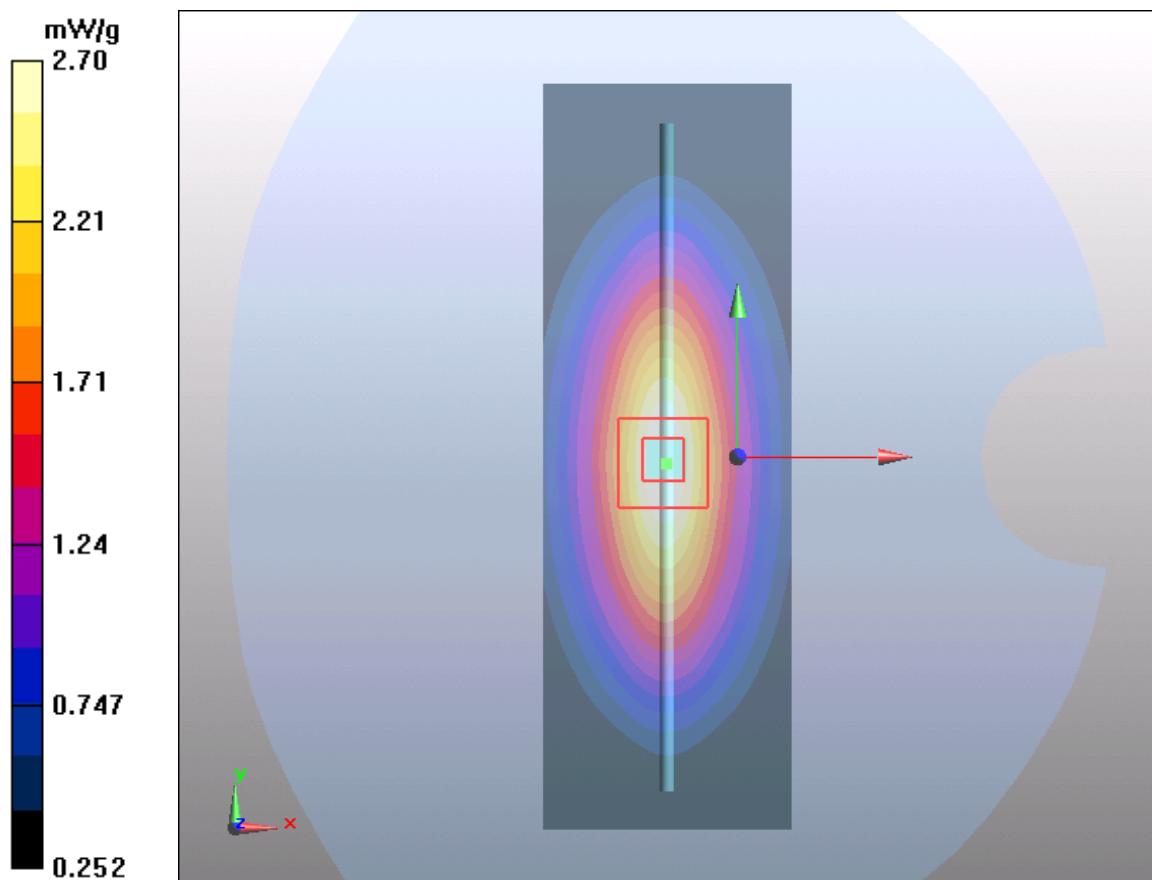

Plot 4 System Performance Check at 835 MHz TSL

DUT: Dipole 835 MHz; Type: D835V2; Serial: D835V2

Date: 10/17/2020

Communication System: CW; Frequency: 835 MHz; Duty Cycle: 1:1

Medium parameters used: $f = 835 \text{ MHz}$; $\sigma = 0.92 \text{ S/m}$; $\epsilon_r = 41.4$; $\rho = 1000 \text{ kg/m}^3$

Ambient Temperature: $22.3 \text{ }^\circ\text{C}$ Liquid Temperature: $21.5 \text{ }^\circ\text{C}$

Phantom section: Flat Section

DASY5 Configuration:

Sensor-Surface: 1.4mm (Mechanical Surface Detection)

Probe: EX3DV4 - SN3677; ConvF(9.38, 9.38, 9.38); Calibrated: 7/6/2020;

Electronics: DAE4 SN1317; Calibrated: 10/23/2019

Phantom: SAM1; Type: SAM; Serial: TP-1534

Measurement SW: DASY52, Version 52.10 (1); SEMCAD X Version 14.6.11 (7439)

d=15mm, Pin=250mW/Area Scan (4x12x1): Measurement grid: dx=15mm, dy=15mm

Maximum value of SAR (measured) = 2.64 mW/g

d=15mm, Pin=250mW/Zoom Scan(5x5x7)/Cube 0: Measurement grid: dx=8mm, dy=8mm, dz=5mm

Reference Value = 54.4 V/m; Power Drift = -0.076 dB

Peak SAR (extrapolated) = 3.67 W/kg

SAR(1 g) = 2.44 mW/g; SAR(10 g) = 1.61 mW/g

Maximum value of SAR (measured) = 2.66 mW/g

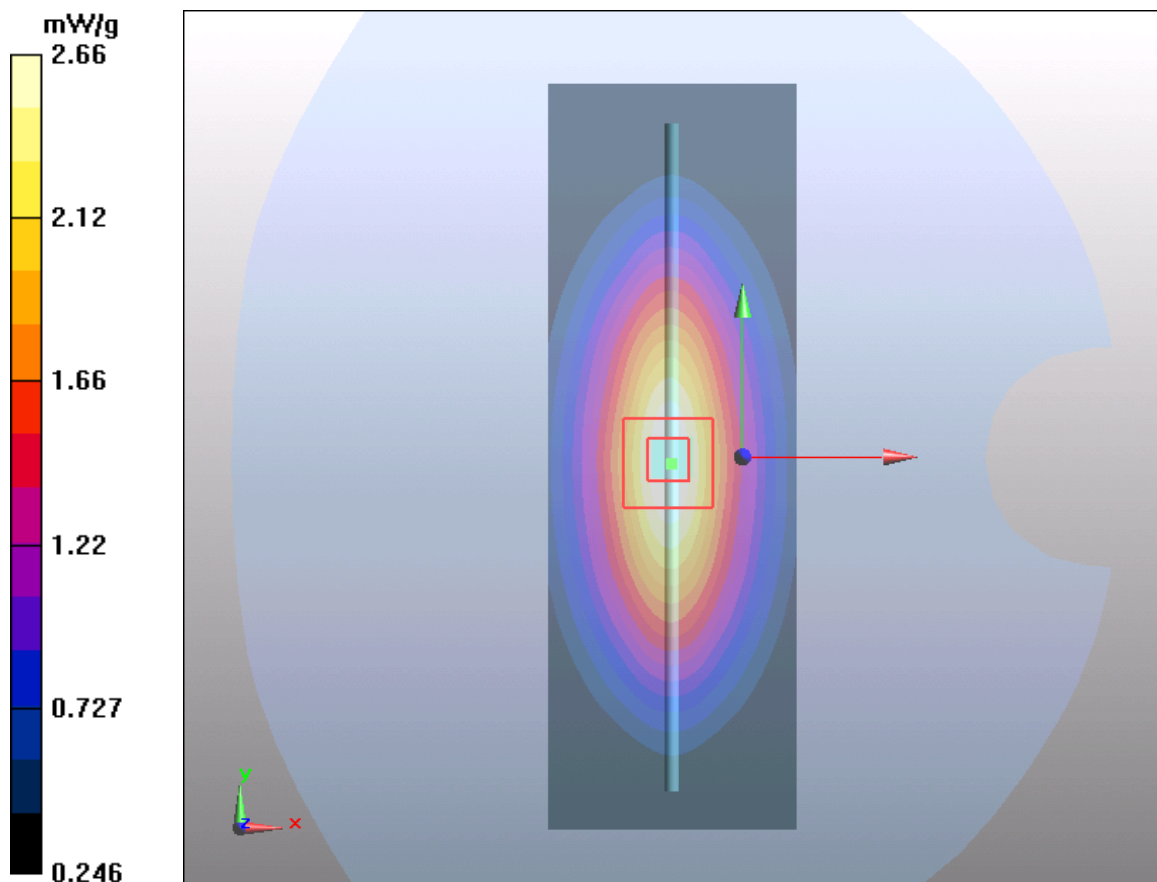

Plot 5 System Performance Check at 1750 MHz TSL

DUT: Dipole 1750 MHz; Type: D1750V2; Serial: D1750V2

Date: 9/22/2020

Communication System: CW; Frequency: 1750 MHz; Duty Cycle: 1:1

Medium parameters used: $f = 1750$ MHz; $\sigma = 1.34$ S/m; $\epsilon_r = 40.2$; $\rho = 1000$ kg/m³

Ambient Temperature: 22.3 °C Liquid Temperature: 21.5 °C

Phantom section: Flat Section

DASY5 Configuration:

Sensor-Surface: 1.4mm (Mechanical Surface Detection)

Probe: EX3DV4 - SN3677; ConvF(8.25, 8.25, 8.25); Calibrated: 7/6/2020;

Electronics: DAE4 SN1317; Calibrated: 10/23/2019

Phantom: SAM1; Type: SAM; Serial: TP-1534

Measurement SW: DASY52, Version 52.10 (1); SEMCAD X Version 14.6.11 (7439)

d=10mm, Pin=250mW/Area Scan (5x8x1): Measurement grid: dx=15mm, dy=15mm

Maximum value of SAR (measured) = 9.78 mW/g

d=10mm, Pin=250mW/Zoom Scan (5x5x7)/Cube 0: Measurement grid: dx=8mm, dy=8mm,

dz=5mm

Reference Value = 80 V/m; Power Drift = 0.075 dB

Peak SAR (extrapolated) = 15.5 W/kg

SAR(1 g) = 8.95 mW/g; SAR(10 g) = 4.5 mW/g

Maximum value of SAR (measured) = 9.46 mW/g

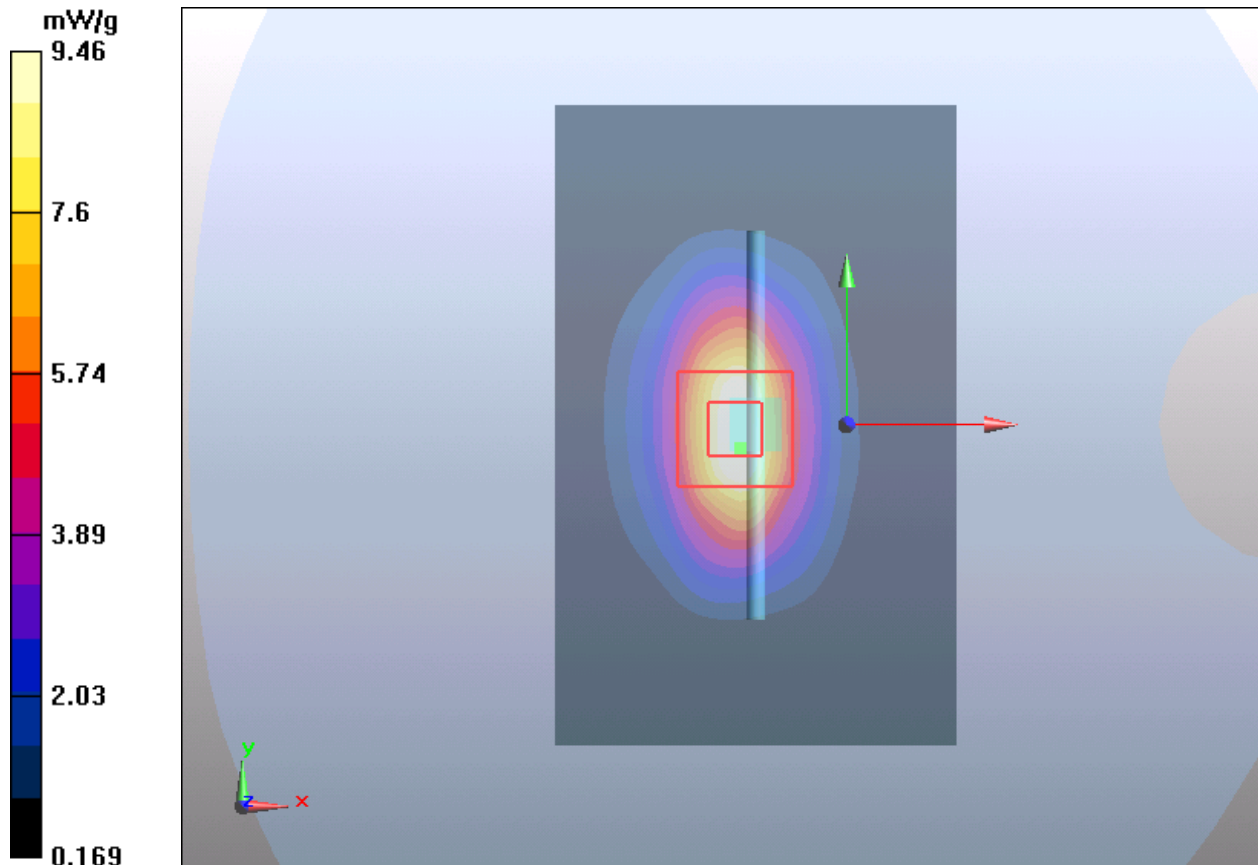

Plot 6 System Performance Check at 1750 MHz TSL**DUT: Dipole 1750 MHz; Type: D1750V2; Serial: D1750V2**

Date: 9/25/2020

Communication System: CW; Frequency: 1750 MHz; Duty Cycle: 1:1

Medium parameters used: $f = 1750$ MHz; $\sigma = 1.35$ S/m; $\epsilon_r = 40.1$; $\rho = 1000$ kg/m³

Ambient Temperature: 22.3 °C Liquid Temperature: 21.5 °C

Phantom section: Flat Section

DASY5 Configuration:

Sensor-Surface: 1.4mm (Mechanical Surface Detection)

Probe: EX3DV4 - SN3677; ConvF(8.25, 8.25, 8.25); Calibrated: 7/6/2020;

Electronics: DAE4 SN1317; Calibrated: 10/23/2019

Phantom: SAM1; Type: SAM; Serial: TP-1534

Measurement SW: DASY52, Version 52.10 (1); SEMCAD X Version 14.6.11 (7439)

d=10mm, Pin=250mW/Area Scan (5x8x1): Measurement grid: dx=15mm, dy=15mm

Maximum value of SAR (measured) = 9.77 mW/g

d=10mm, Pin=250mW/Zoom Scan (5x5x7)/Cube 0: Measurement grid: dx=8mm, dy=8mm, dz=5mm

Reference Value = 80 V/m; Power Drift = 0.055 dB

Peak SAR (extrapolated) = 15.51 W/kg

SAR(1 g) = 9.11 mW/g; SAR(10 g) = 4.77 mW/g

Maximum value of SAR (measured) = 9.87 mW/g

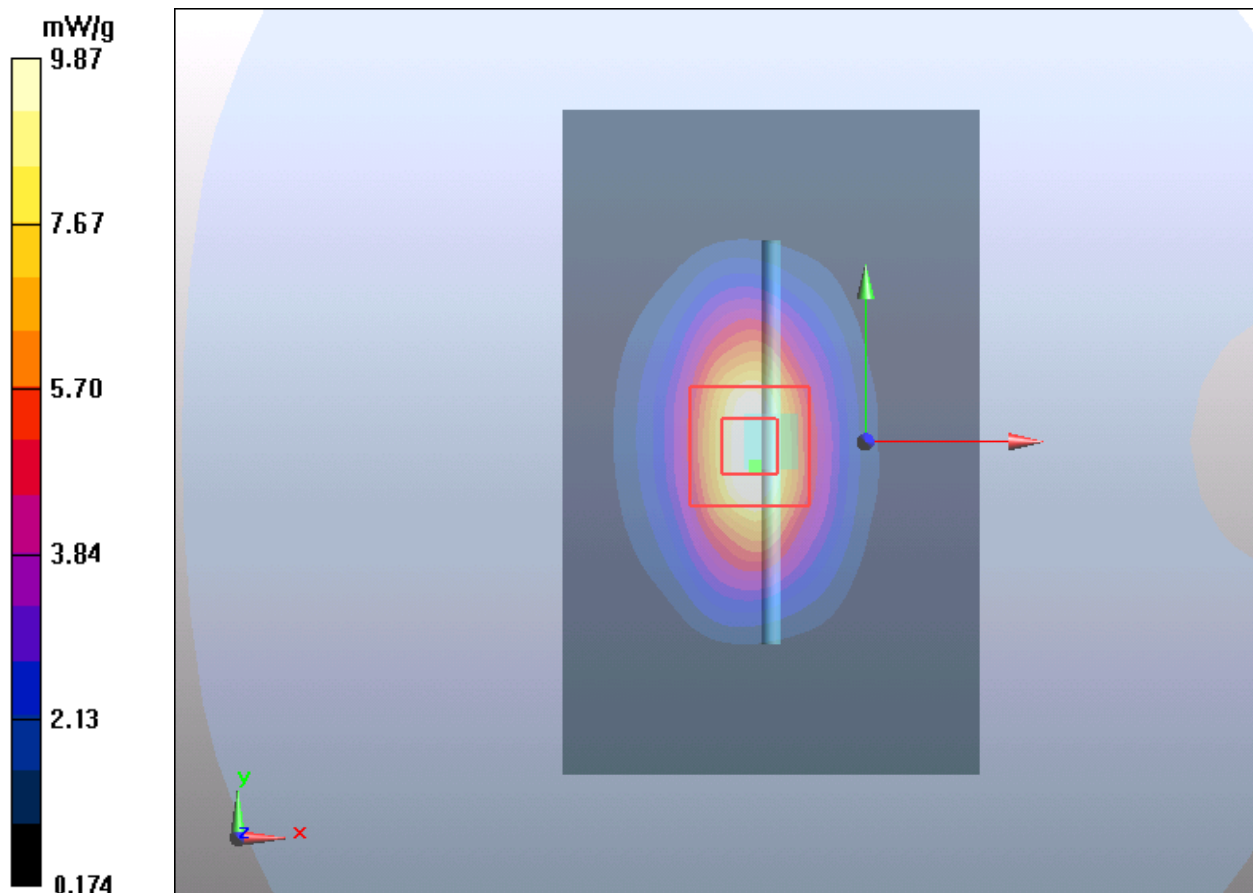

Plot 7 System Performance Check at 1750 MHz TSL

DUT: Dipole 1750 MHz; Type: D1750V2; Serial: D1750V2

Date: 8/28/2020

Communication System: CW; Frequency: 1750 MHz; Duty Cycle: 1:1

Medium parameters used: $f = 1750 \text{ MHz}$; $\sigma = 1.36 \text{ mho/m}$; $\epsilon_r = 40.0$; $\rho = 1000 \text{ kg/m}^3$

Ambient Temperature: $22.3 \text{ }^\circ\text{C}$ Liquid Temperature: $21.5 \text{ }^\circ\text{C}$

Phantom section: Flat Section

DASY5 Configuration:

Sensor-Surface: 1.4mm (Mechanical Surface Detection)

Probe: EX3DV4 - SN3677; ConvF(8.25, 8.25, 8.25); Calibrated: 7/6/2020;

Electronics: DAE4 SN1317; Calibrated: 10/23/2019

Phantom: SAM1; Type: SAM; Serial: TP-1534

Measurement SW: DASY52, Version 52.10 (1); SEMCAD X Version 14.6.11 (7439)

d=10mm, Pin=250mW/Area Scan (5x8x1): Measurement grid: dx=15mm, dy=15mm

Maximum value of SAR (measured) = 9.11 mW/g

d=10mm, Pin=250mW/Zoom Scan (5x5x7)/Cube 0: Measurement grid: dx=8mm, dy=8mm, dz=5mm

Reference Value = 80 V/m; Power Drift = 0.075 dB

Peak SAR (extrapolated) = 15.47 W/kg

SAR(1 g) = 8.96 mW/g; SAR(10 g) = 4.75 mW/g

Maximum value of SAR (measured) = 9.46 mW/g

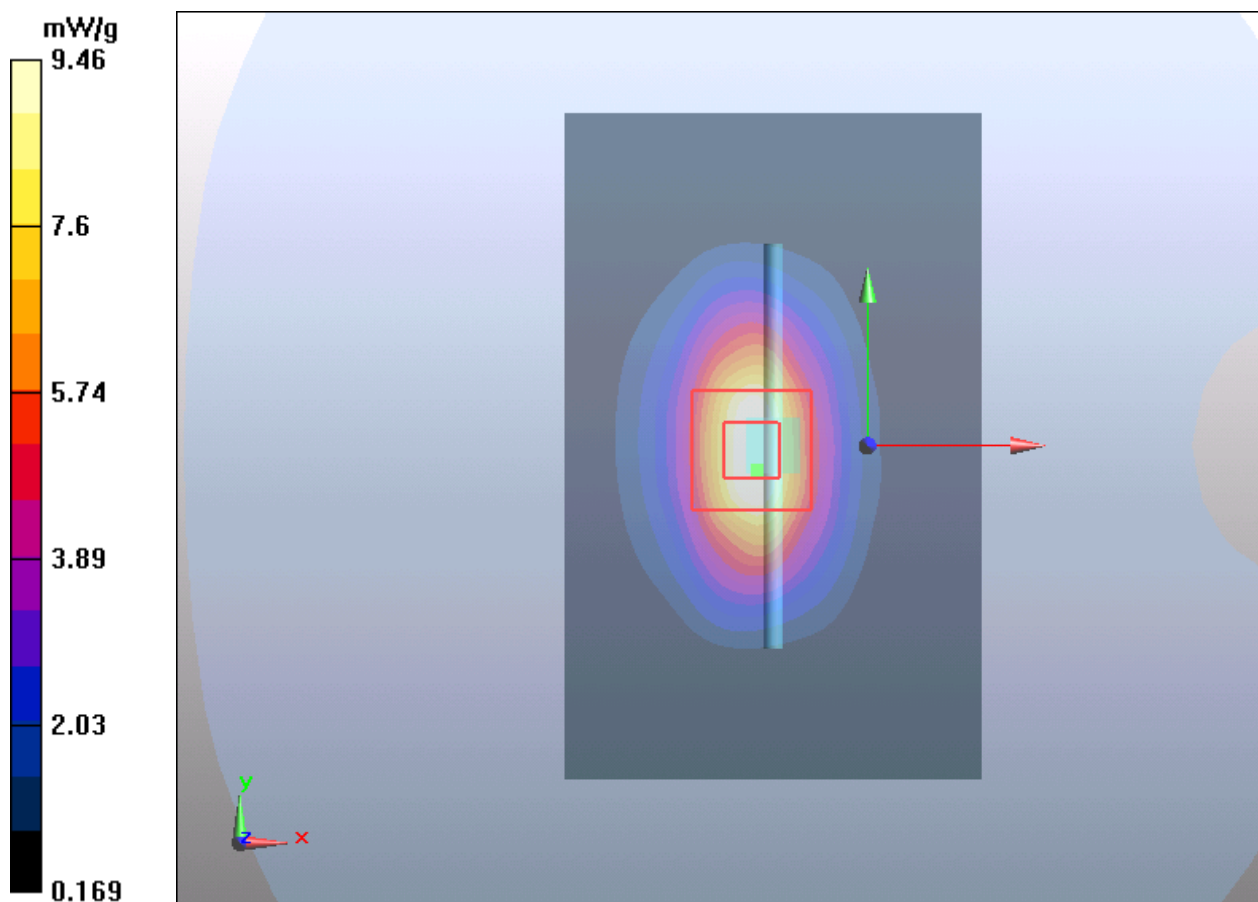

Plot 8 System Performance Check at 1900 MHz TSL

DUT: Dipole 1900 MHz; Type: D1900V2; Serial: D1900V2

Date: 9/3/2020

Communication System: CW; Frequency: 1900 MHz; Duty Cycle: 1:1

Medium parameters used: $f = 1900$ MHz; $\sigma = 1.41$ S/m; $\epsilon_r = 40.1$; $\rho = 1000$ kg/m³

Ambient Temperature: 22.3 °C Liquid Temperature: 21.5 °C

Phantom section: Flat Section

DASY5 Configuration:

Sensor-Surface: 1.4mm (Mechanical Surface Detection)

Probe: EX3DV4 - SN3677; ConvF(7.90, 7.90, 7.90); Calibrated: 7/6/2020;

Electronics: DAE4 SN1317; Calibrated: 10/23/2019

Phantom: SAM1; Type: SAM; Serial: TP-1534

Measurement SW: DASY52, Version 52.10 (1); SEMCAD X Version 14.6.11 (7439)

d=10mm, Pin=250mW/Area Scan (4x7x1): Measurement grid: dx=15mm, dy=15mm

Maximum value of SAR (measured) = 11.3 mW/g

d=10mm, Pin=250mW/Zoom Scan (5x5x7)/Cube 0: Measurement grid: dx=8mm, dy=8mm, dz=5mm

Reference Value = 85.5 V/m; Power Drift = 0.028 dB

Peak SAR (extrapolated) = 17.8 W/kg

SAR(1 g) = 9.86 mW/g; SAR(10 g) = 4.9 mW/g

Maximum value of SAR (measured) = 10.7 mW/g

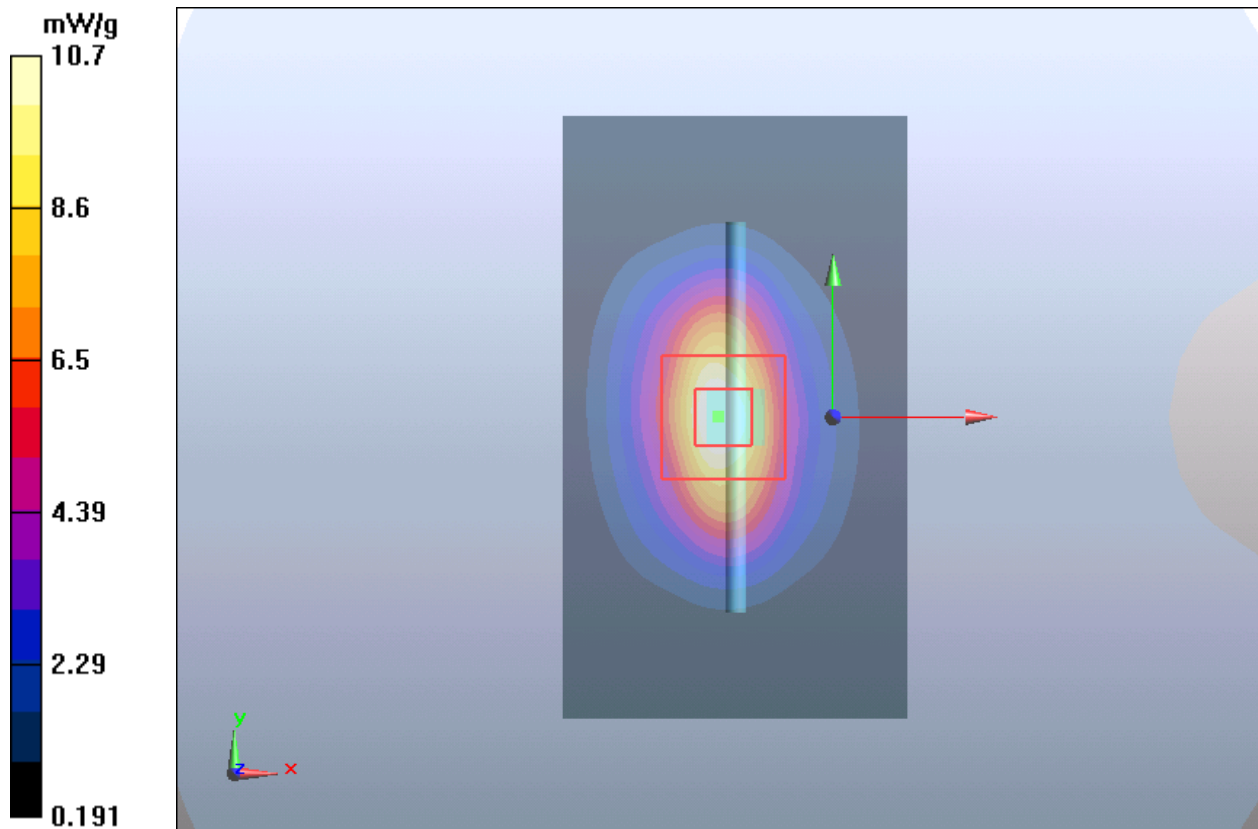

Plot 9 System Performance Check at 1900 MHz TSL

DUT: Dipole 1900 MHz; Type: D1900V2; Serial: D1900V2

Date: 9/4/2020

Communication System: CW; Frequency: 1900 MHz; Duty Cycle: 1:1

Medium parameters used: $f = 1900$ MHz; $\sigma = 1.43$ S/m; $\epsilon_r = 40.2$; $\rho = 1000$ kg/m³

Ambient Temperature: 22.3 °C Liquid Temperature: 21.5 °C

Phantom section: Flat Section

DASY5 Configuration:

Sensor-Surface: 1.4mm (Mechanical Surface Detection)

Probe: EX3DV4 - SN3677; ConvF(7.90, 7.90, 7.90); Calibrated: 7/6/2020;

Electronics: DAE4 SN1317; Calibrated: 10/23/2019

Phantom: SAM1; Type: SAM; Serial: TP-1534

Measurement SW: DASY52, Version 52.10 (1); SEMCAD X Version 14.6.11 (7439)

d=10mm, Pin=250mW/Area Scan (4x7x1): Measurement grid: dx=15mm, dy=15mm

Maximum value of SAR (measured) = 11.23 mW/g

d=10mm, Pin=250mW/Zoom Scan (5x5x7)/Cube 0: Measurement grid: dx=8mm, dy=8mm, dz=5mm

Reference Value = 85.0 V/m; Power Drift = 0.01 dB

Peak SAR (extrapolated) = 17.8 W/kg

SAR(1 g) = 9.82 mW/g; SAR(10 g) = 4.93 mW/g

Maximum value of SAR (measured) = 11.12 mW/g

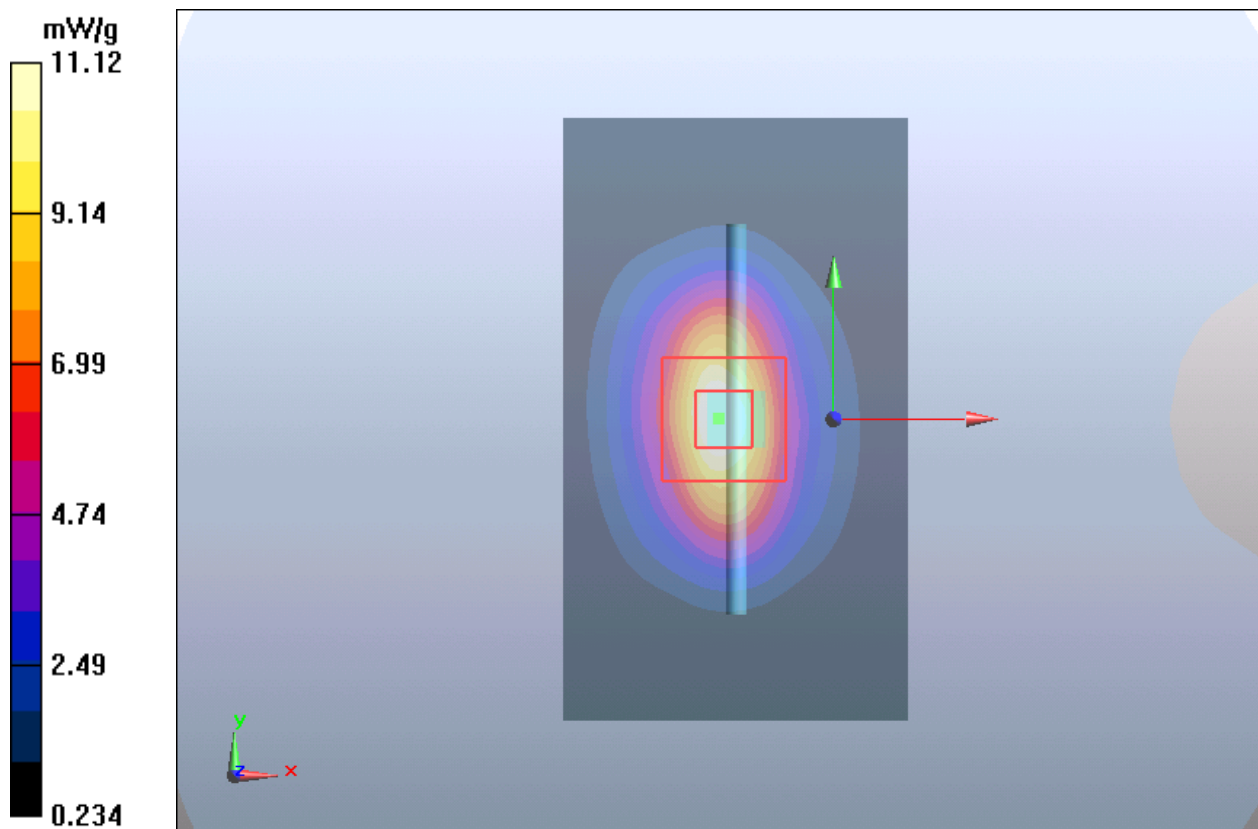

Plot 10 System Performance Check at 2450 MHz TSL

DUT: Dipole 2450 MHz; Type: D2450V2; Serial: D2450V2

Date: 9/10/2020

Communication System: CW; Frequency: 2450 MHz; Duty Cycle: 1:1

Medium parameters used: $f = 2450$ MHz; $\sigma = 1.81$ S/m; $\epsilon_r = 38.9$; $\rho = 1000$ kg/m³

Ambient Temperature: 22.3 °C Liquid Temperature: 21.5 °C

Phantom section: Flat Section

DASY5 Configuration:

Sensor-Surface: 1.4mm (Mechanical Surface Detection)

Probe: EX3DV4 - SN3677; ConvF(7.54, 7.54, 7.54); Calibrated: 7/6/2020;

Electronics: DAE4 SN1317; Calibrated: 10/23/2019

Phantom: SAM1; Type: SAM; Serial: TP-1534

Measurement SW: DASY52, Version 52.10 (1); SEMCAD X Version 14.6.11 (7439)

d=10mm, Pin=250mW/Area Scan (4x7x1): Measurement grid: dx=12mm, dy=12mm

Maximum value of SAR (measured) = 18.2 mW/g

d=10mm, Pin=250mW/Zoom Scan (7x7x7)/Cube 0: Measurement grid: dx=5mm, dy=5mm, dz=5mm

Reference Value = 88.8 V/m; Power Drift = 0.075 dB

Peak SAR (extrapolated) = 30 W/kg

SAR(1 g) = 13.73 mW/g; SAR(10 g) = 6.22 mW/g

Maximum value of SAR (measured) = 15.9 mW/g

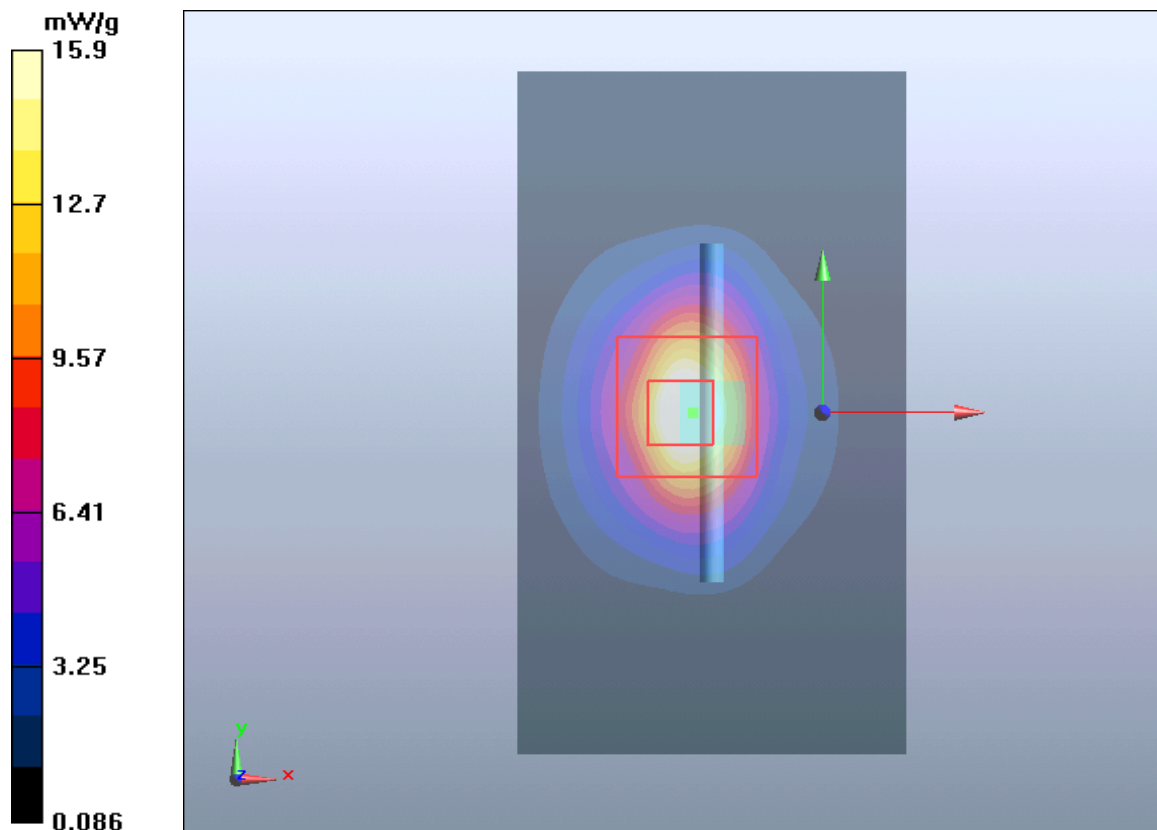

Plot 11 System Performance Check at 5250 MHz TSL**DUT: Dipole 5250 MHz; Type: D5GHzV2; Serial: D5GHzV2**

Date: 10/9/2020

Communication System: CW; Frequency: 5250 MHz; Duty Cycle: 1:1

Medium parameters used: $f = 5250$ MHz; $\sigma = 4.80$ S/m; $\epsilon_r = 35.5$; $\rho = 1000$ kg/m³

Ambient Temperature: 22.3 °C Liquid Temperature: 21.5 °C

Phantom section: Flat Section

DASY5 Configuration:

Sensor-Surface: 1.4mm (Mechanical Surface Detection)

Probe: EX3DV4 - SN3677; ConvF(5.55, 5.55, 5.55); Calibrated: 7/6/2020;

Electronics: DAE4 SN1317; Calibrated: 10/23/2019

Phantom: SAM1; Type: SAM; Serial: TP-1534

Measurement SW: DASY52, Version 52.10 (1); SEMCAD X Version 14.6.11 (7439)

d=10mm, Pin=100mW/Area Scan (6x10x1): Measurement grid: dx=10mm, dy=10mm

Maximum value of SAR (measured) = 9.14 mW/g

d=10mm, Pin=100mW/Zoom Scan (7x7x12)/Cube 0: Measurement grid: dx=4mm, dy=4mm, dz=2mm

Reference Value = 33.6 V/m; Power Drift = -0.095 dB

Peak SAR (extrapolated) = 52.2 W/kg

SAR(1 g) = 7.86 mW/g; SAR(10 g) = 2.25 mW/g

Maximum value of SAR (measured) = 9.73 mW/g

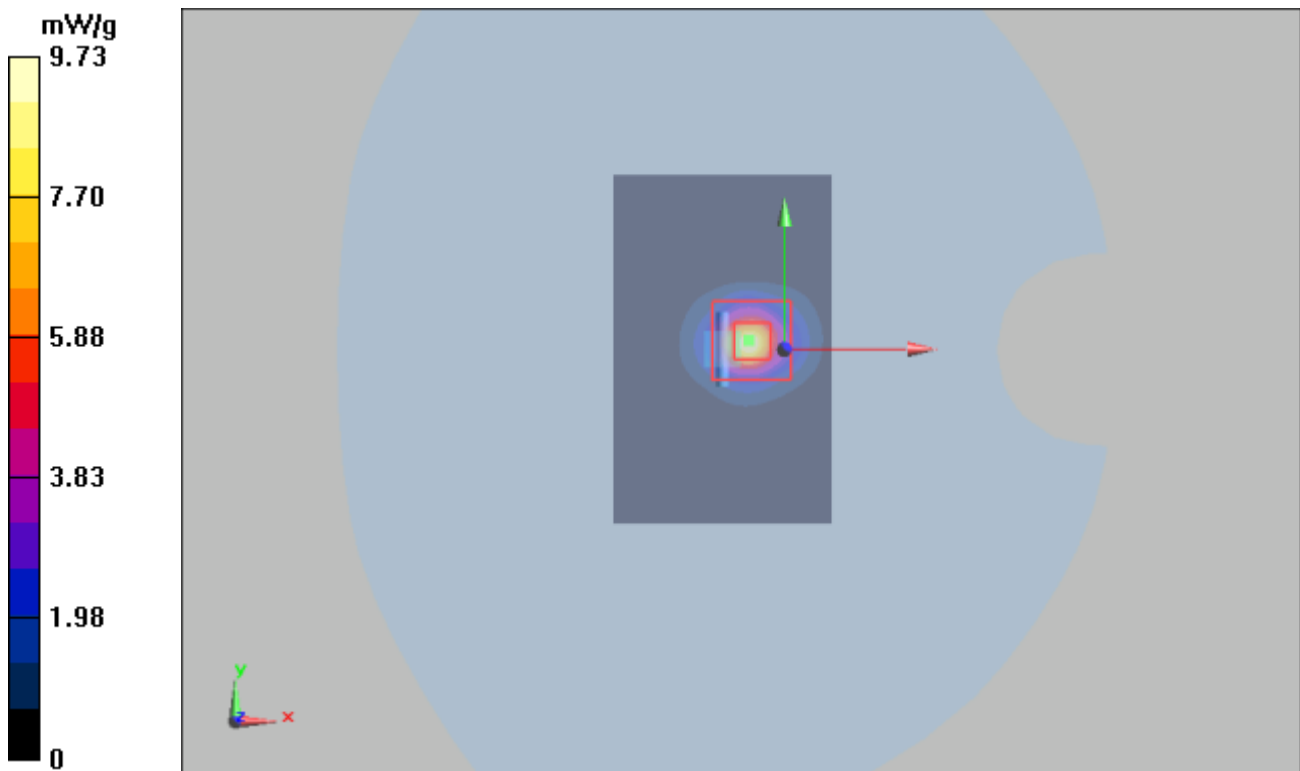

Plot 12 System Performance Check at 5750 MHz TSL**DUT: Dipole 5750 MHz; Type: D5GHzV2; Serial: D5GHzV2**

Date: 10/9/2020

Communication System: CW; Frequency: 5750 MHz; Duty Cycle: 1:1

Medium parameters used: $f = 5750$ MHz; $\sigma = 5.21$ S/m; $\epsilon_r = 34.9$; $\rho = 1000$ kg/m³

Ambient Temperature: 22.3 °C Liquid Temperature: 21.5 °C

Phantom section: Flat Section

DASY5 Configuration:

Sensor-Surface: 1.4mm (Mechanical Surface Detection)

Probe: EX3DV4 - SN3677; ConvF(5.00, 5.00, 5.00); Calibrated: 7/6/2020;

Electronics: DAE4 SN1317; Calibrated: 10/23/2019

Phantom: SAM1; Type: SAM; Serial: TP-1534

Measurement SW: DASY52, Version 52.10 (1); SEMCAD X Version 14.6.11 (7439)

d=10mm, Pin=100mW/Area Scan (6x10x1): Measurement grid: dx=10mm, dy=10mm

Maximum value of SAR (measured) = 8.31 mW/g

d=10mm, Pin=100mW/Zoom Scan (7x7x12)/Cube 0: Measurement grid: dx=4mm, dy=4mm, dz=2mm

Reference Value = 23.1 V/m; Power Drift = 0.044 dB

Peak SAR (extrapolated) = 23.4 W/kg

SAR(1 g) = 7.68 mW/g; SAR(10 g) = 2.27 mW/g

Maximum value of SAR (measured) = 8.976 mW/g

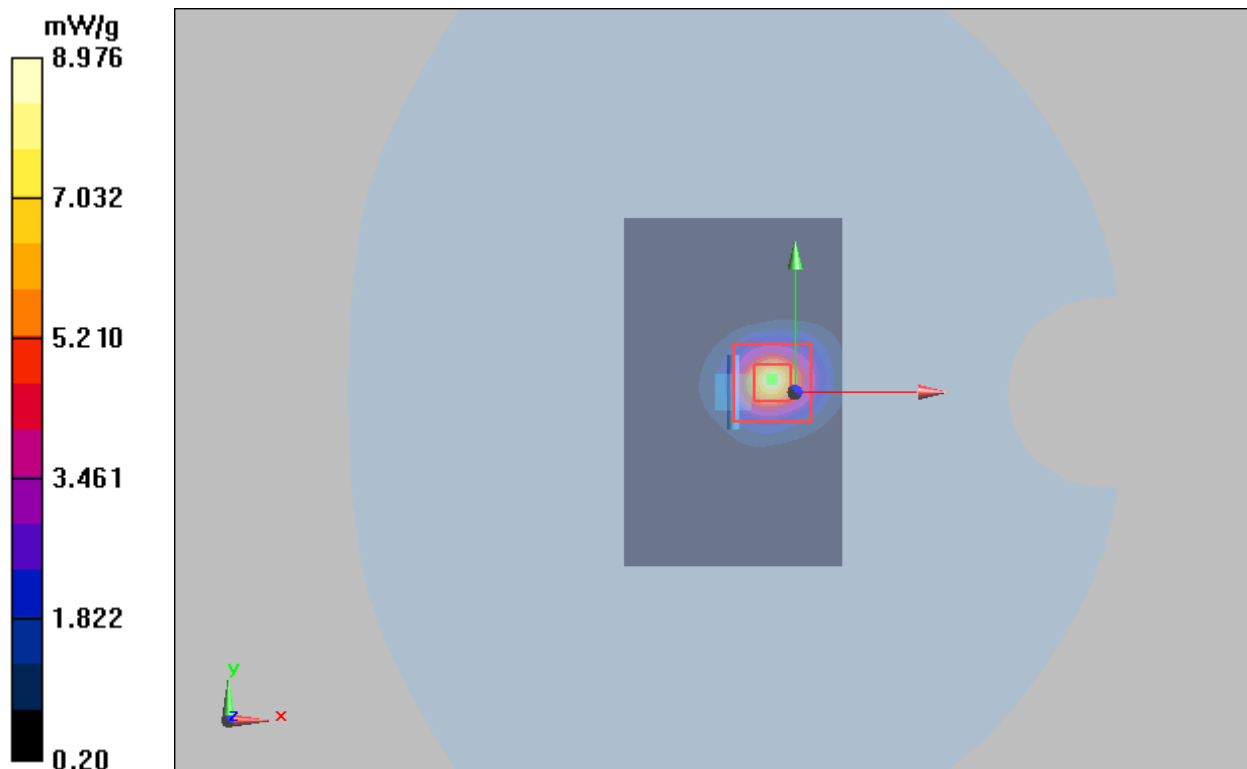

ANNEX C: Highest Graph Results

Plot 13 LTE Band 2 50%RB Left Cheek Low

Date: 9/3/2020

Communication System: UID 0, LTE (0); Frequency: 1860 MHz; Duty Cycle: 1:1

Medium parameters used: $f = 1860$ MHz; $\sigma = 1.379$ S/m; $\epsilon_r = 38.4$; $\rho = 1000$ kg/m³

Ambient Temperature: 22.3 °C Liquid Temperature: 21.5 °C

Phantom section: Left Section

DASY5 Configuration:

Sensor-Surface: 1.4mm (Mechanical Surface Detection)

Probe: EX3DV4 - SN3677; ConvF(7.90, 7.90, 7.90); Calibrated: 7/6/2020;

Electronics: DAE4 SN1317; Calibrated: 10/23/2019

Phantom: SAM1; Type: SAM; Serial: TP-1534

Measurement SW: DASY52, Version 52.10 (1); SEMCAD X Version 14.6.11 (7439)

Left Cheek Low/Area Scan (8x14x1): Measurement grid: dx=15mm, dy=15mm

Maximum value of SAR (measured) = 0.0876 W/kg

Left Cheek Low/Zoom Scan (5x5x7)/Cube 0: Measurement grid: dx=8mm, dy=8mm, dz=5mm

Reference Value = 2.246 V/m; Power Drift = 0.13 dB

Peak SAR (extrapolated) = 0.134 W/kg

SAR(1 g) = 0.082 W/kg; SAR(10 g) = 0.049 W/kg

Maximum value of SAR (measured) = 0.088 W/kg

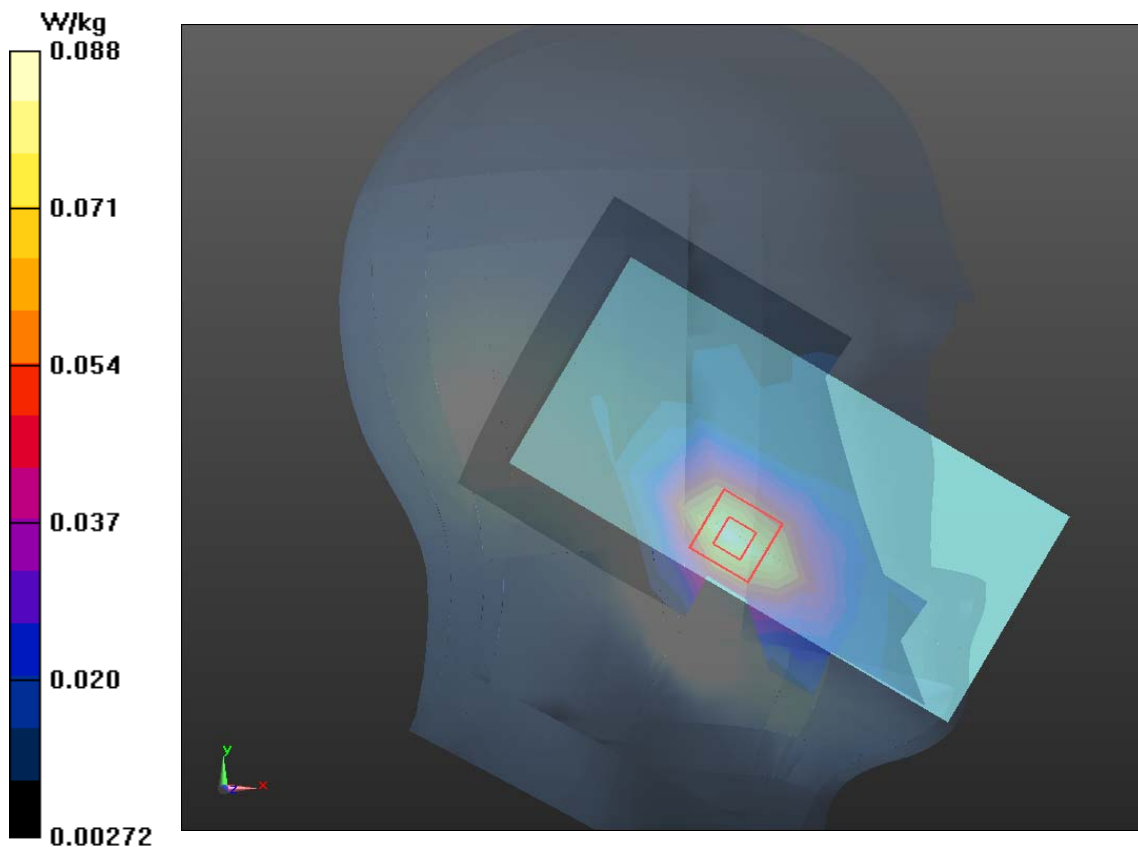

Plot 14 LTE Band 2 1RB Back Side High(Distance 15mm)

Date: 9/3/2020

Communication System: UID 0, LTE (0); Frequency: 1900 MHz;Duty Cycle: 1:1

Medium parameters used: $f = 1900$ MHz; $\sigma = 1.408$ S/m; $\epsilon_r = 38.294$; $\rho = 1000$ kg/m³

Ambient Temperature:22.3 °C Liquid Temperature: 21.5°C

Phantom section: Flat Section

DASY5 Configuration:

Sensor-Surface: 1.4mm (Mechanical Surface Detection)

Probe: EX3DV4 - SN3677; ConvF(7.90, 7.90, 7.90); Calibrated: 7/6/2020;

Electronics: DAE4 SN1317; Calibrated: 10/23/2019

Phantom: SAM1; Type: SAM; Serial: TP-1534

Measurement SW: DASY52, Version 52.10 (1); SEMCAD X Version 14.6.11 (7439)

Back Side High/Area Scan (8x15x1): Measurement grid: dx=15mm, dy=15mm

Maximum value of SAR (measured) = 1.39 W/kg

Back Side High/Zoom Scan (5x5x7)/Cube 0: Measurement grid: dx=8mm, dy=8mm, dz=5mm

Reference Value = 8.050 V/m; Power Drift = -0.09 dB

Peak SAR (extrapolated) = 2.36 W/kg

SAR(1 g) = 1.39 W/kg; SAR(10 g) = 0.763 W/kg

Maximum value of SAR (measured) = 1.54 W/kg

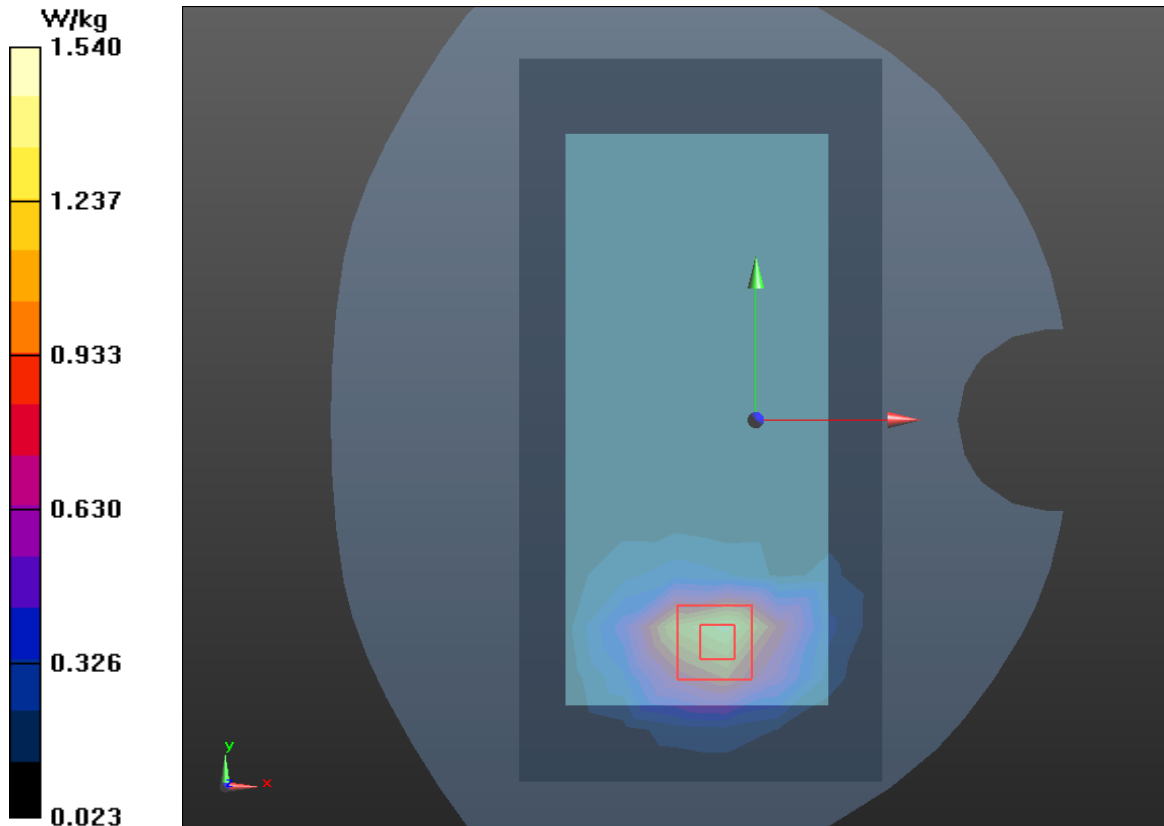

Plot 15 LTE Band 2 1RB Bottom Edge Low (Distance 10mm)

Date: 9/3/2020

Communication System: UID 0, LTE (0); Frequency: 1860 MHz; Duty Cycle: 1:1

Medium parameters used: $f = 1860$ MHz; $\sigma = 1.407$ S/m; $\epsilon_r = 39.071$; $\rho = 1000$ kg/m³

Ambient Temperature: 22.3 °C Liquid Temperature: 21.5 °C

Phantom section: Flat Section

DASY5 Configuration:

Sensor-Surface: 1.4mm (Mechanical Surface Detection)

Probe: EX3DV4 - SN3677; ConvF(7.90, 7.90, 7.90); Calibrated: 7/6/2020;

Electronics: DAE4 SN1317; Calibrated: 10/23/2019

Phantom: SAM1; Type: SAM; Serial: TP-1534

Measurement SW: DASY52, Version 52.10 (1); SEMCAD X Version 14.6.11 (7439)

Bottom Edge Low/Area Scan (4x8x1): Measurement grid: dx=15mm, dy=15mm

Maximum value of SAR (measured) = 1.03 W/kg

Bottom Edge Low/Zoom Scan (5x5x7)/Cube 0: Measurement grid: dx=8mm, dy=8mm, dz=5mm

Reference Value = 21.16 V/m; Power Drift = 0.045 dB

Peak SAR (extrapolated) = 1.70 W/kg

SAR(1 g) = 0.962 W/kg; SAR(10 g) = 0.505 W/kg

Maximum value of SAR (measured) = 1.04 W/kg

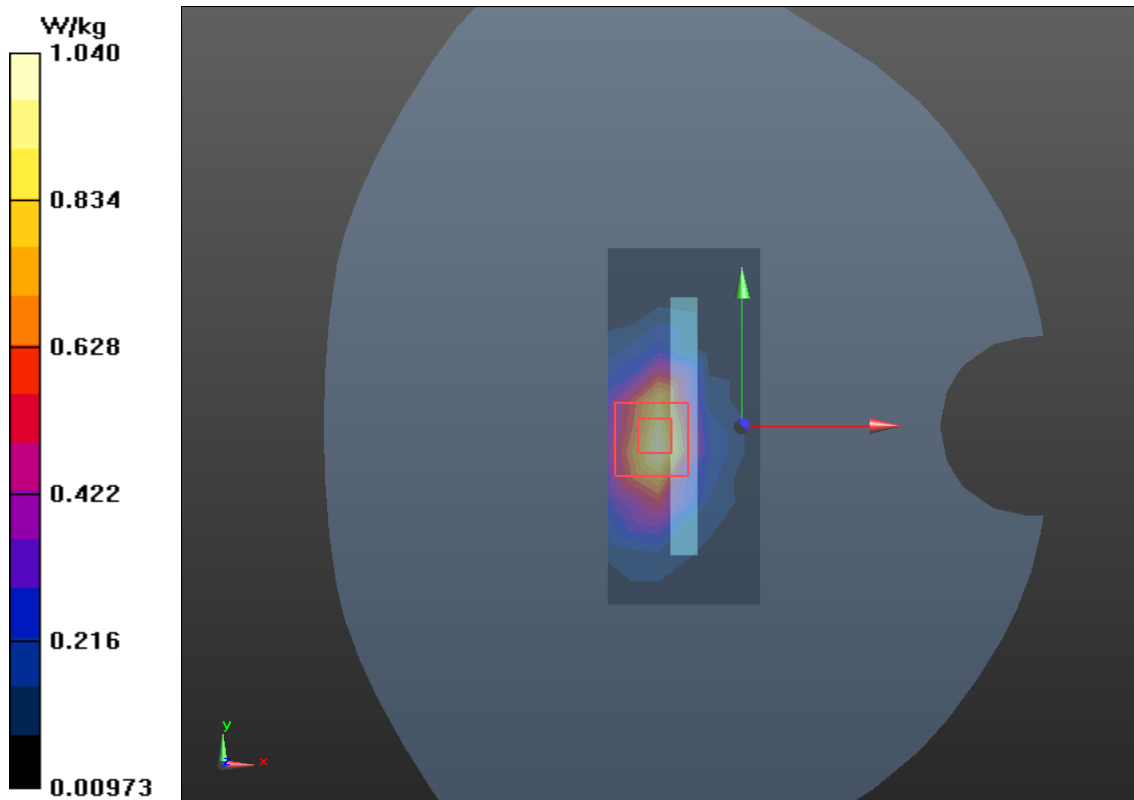

Plot 16 LTE Band 2 1RB Back Side Low (Distance 0mm)

Date: 9/3/2020

Communication System: UID 0, LTE (0); Frequency: 1860 MHz; Duty Cycle: 1:1

Medium parameters used: $f = 1860$ MHz; $\sigma = 1.379$ S/m; $\epsilon_r = 38.4$; $\rho = 1000$ kg/m³

Ambient Temperature: 22.3 °C Liquid Temperature: 21.5 °C

Phantom section: Flat Section

DASY5 Configuration:

Sensor-Surface: 1.4mm (Mechanical Surface Detection)

Probe: EX3DV4 - SN3677; ConvF(7.90, 7.90, 7.90); Calibrated: 7/6/2020;

Electronics: DAE4 SN1317; Calibrated: 10/23/2019

Phantom: SAM1; Type: SAM; Serial: TP-1534

Measurement SW: DASY52, Version 52.10 (1); SEMCAD X Version 14.6.11 (7439)

Back Side Low/Area Scan (8x15x1): Measurement grid: dx=15mm, dy=15mm

Maximum value of SAR (measured) = 3.27 W/kg

Back Side Low/Zoom Scan (5x5x7)/Cube 0: Measurement grid: dx=8mm, dy=8mm, dz=5mm

Reference Value = 3.569 V/m; Power Drift = -0.03 dB

Peak SAR (extrapolated) = 11.8 W/kg

SAR(1 g) = 5.04 W/kg; SAR(10 g) = 2.33 W/kg

Maximum value of SAR (measured) = 5.56 W/kg

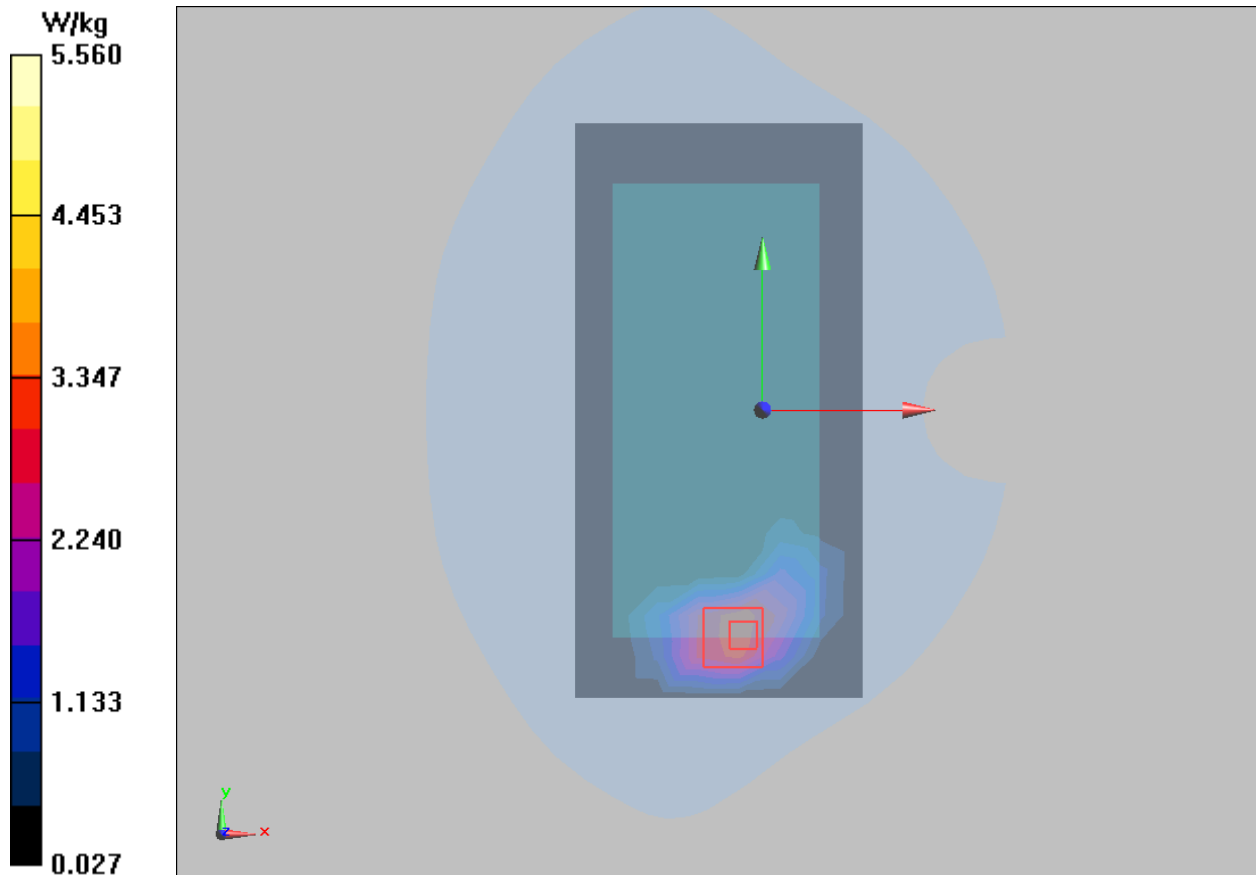

Plot 17 LTE (EN-DC) Band 2 1RB Left Cheek Low

Date: 9/3/2020

Communication System: UID 0, LTE (0); Frequency: 1880 MHz; Duty Cycle: 1:1

Medium parameters used: $f = 1880 \text{ MHz}$; $\sigma = 1.393 \text{ S/m}$; $\epsilon_r = 38.344$; $\rho = 1000 \text{ kg/m}^3$

Ambient Temperature: $22.3 \text{ }^\circ\text{C}$ Liquid Temperature: $21.5 \text{ }^\circ\text{C}$

Phantom section: Right Section

DASY5 Configuration:

Sensor-Surface: 1.4mm (Mechanical Surface Detection)

Probe: EX3DV4 - SN3677; ConvF(7.90, 7.90, 7.90); Calibrated: 7/6/2020;

Electronics: DAE4 SN1317; Calibrated: 10/23/2019

Phantom: SAM1; Type: SAM; Serial: TP-1534

Measurement SW: DASY52, Version 52.10 (1); SEMCAD X Version 14.6.11 (7439)

Right Cheek Middle/Area Scan (8x14x1): Measurement grid: $dx=15\text{mm}$, $dy=15\text{mm}$

Maximum value of SAR (measured) = 0.0598 W/kg

Right Cheek Middle/Zoom Scan (5x5x7)/Cube 0: Measurement grid: $dx=8\text{mm}$, $dy=8\text{mm}$, $dz=5\text{mm}$

Reference Value = 3.273 V/m ; Power Drift = -0.078 dB

Peak SAR (extrapolated) = 0.0870 W/kg

SAR(1 g) = 0.058 W/kg ; SAR(10 g) = 0.037 W/kg

Maximum value of SAR (measured) = 0.0619 W/kg

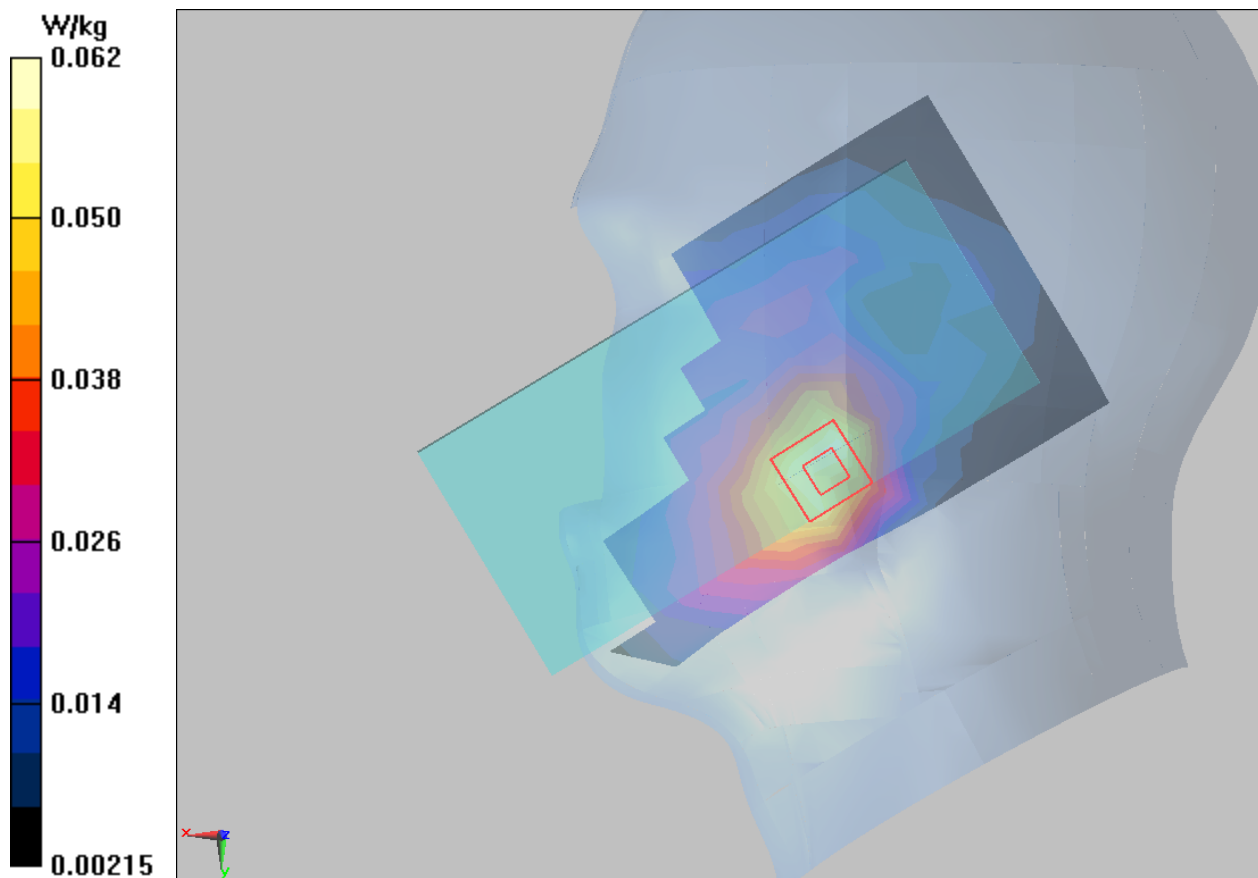

Plot 18 LTE (EN-DC) Band 2 1RB Back Side High(Distance 15mm)

Date: 9/3/2020

Communication System: UID 0, LTE (0); Frequency: 1860 MHz; Duty Cycle: 1:1

Medium parameters used: $f = 1860$ MHz; $\sigma = 1.379$ S/m; $\epsilon_r = 38.4$; $\rho = 1000$ kg/m³

Ambient Temperature: 22.3 °C Liquid Temperature: 21.5 °C

Phantom section: Flat Section

DASY5 Configuration:

Sensor-Surface: 1.4mm (Mechanical Surface Detection)

Probe: EX3DV4 - SN3677; ConvF(7.90, 7.90, 7.90); Calibrated: 7/6/2020;

Electronics: DAE4 SN1317; Calibrated: 10/23/2019

Phantom: SAM1; Type: SAM; Serial: TP-1534

Measurement SW: DASY52, Version 52.10 (1); SEMCAD X Version 14.6.11 (7439)

Front Side Low/Area Scan (8x15x1): Measurement grid: dx=15mm, dy=15mm

Maximum value of SAR (measured) = 0.120 W/kg

Front Side Low/Zoom Scan (5x5x7)/Cube 0: Measurement grid: dx=8mm, dy=8mm, dz=5mm

Reference Value = 5.366 V/m; Power Drift = 0.11 dB

Peak SAR (extrapolated) = 0.184 W/kg

SAR(1 g) = 0.120 W/kg; SAR(10 g) = 0.075 W/kg

Maximum value of SAR (measured) = 0.129 W/kg

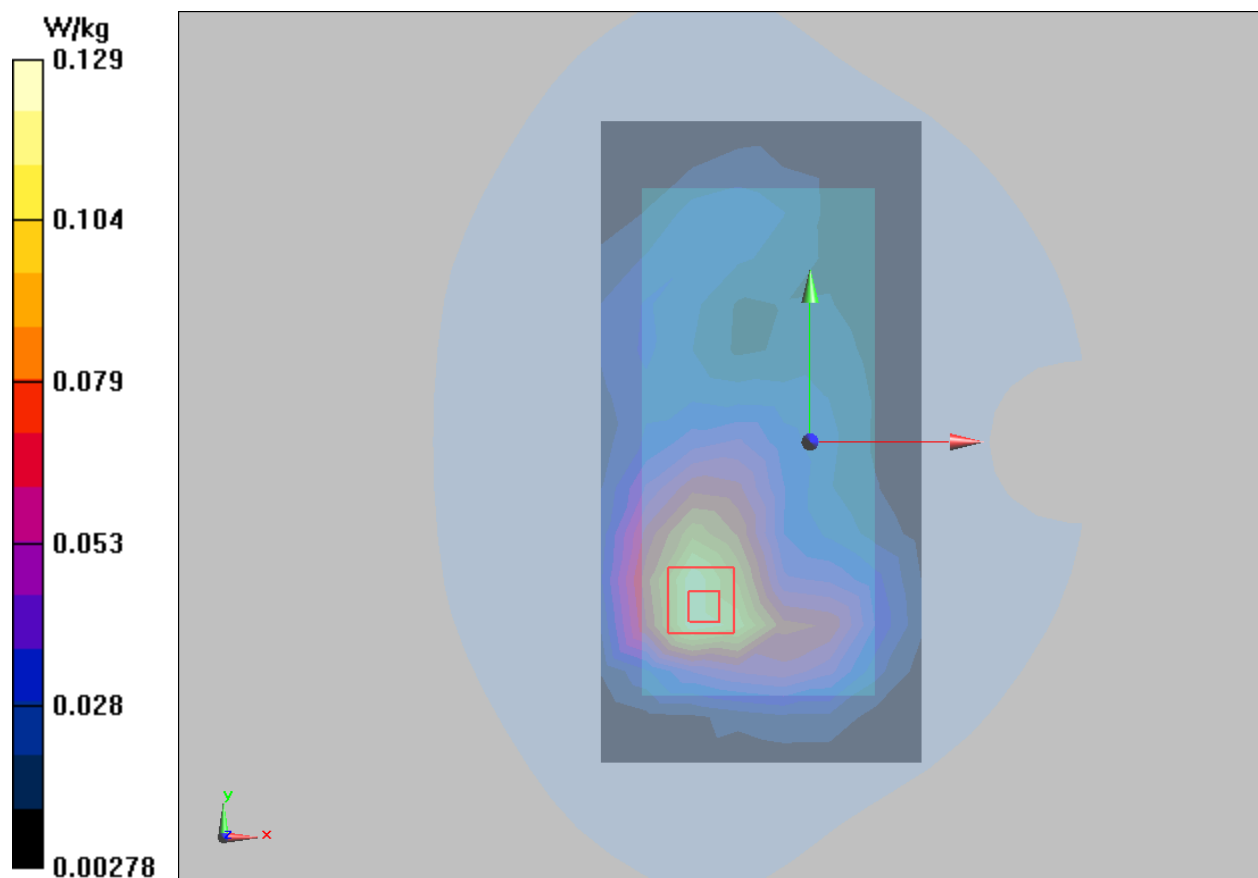

Plot 19 LTE (EN-DC) Band 2 1RB Bottom Edge Low (Distance 10mm)

Date: 9/4/2020

Communication System: UID 0, LTE (0); Frequency: 1880 MHz; Duty Cycle: 1:1

Medium parameters used: $f = 1880$ MHz; $\sigma = 1.393$ S/m; $\epsilon_r = 38.344$; $\rho = 1000$ kg/m³

Ambient Temperature: 22.3 °C Liquid Temperature: 21.5 °C

Phantom section: Flat Section

DASY5 Configuration:

Sensor-Surface: 1.4mm (Mechanical Surface Detection)

Probe: EX3DV4 - SN3677; ConvF(7.90, 7.90, 7.90); Calibrated: 7/6/2020;

Electronics: DAE4 SN1317; Calibrated: 10/23/2019

Phantom: SAM1; Type: SAM; Serial: TP-1534

Measurement SW: DASY52, Version 52.10 (1); SEMCAD X Version 14.6.11 (7439)

Back Side Middle/Area Scan (8x15x1): Measurement grid: dx=15mm, dy=15mm

Maximum value of SAR (measured) = 0.174 W/kg

Back Side Middle/Zoom Scan (5x5x7)/Cube 0: Measurement grid: dx=8mm, dy=8mm, dz=5mm

Reference Value = 7.343 V/m; Power Drift = -0.15 dB

Peak SAR (extrapolated) = 0.302 W/kg

SAR(1 g) = 0.160 W/kg; SAR(10 g) = 0.088 W/kg

Maximum value of SAR (measured) = 0.175 W/kg

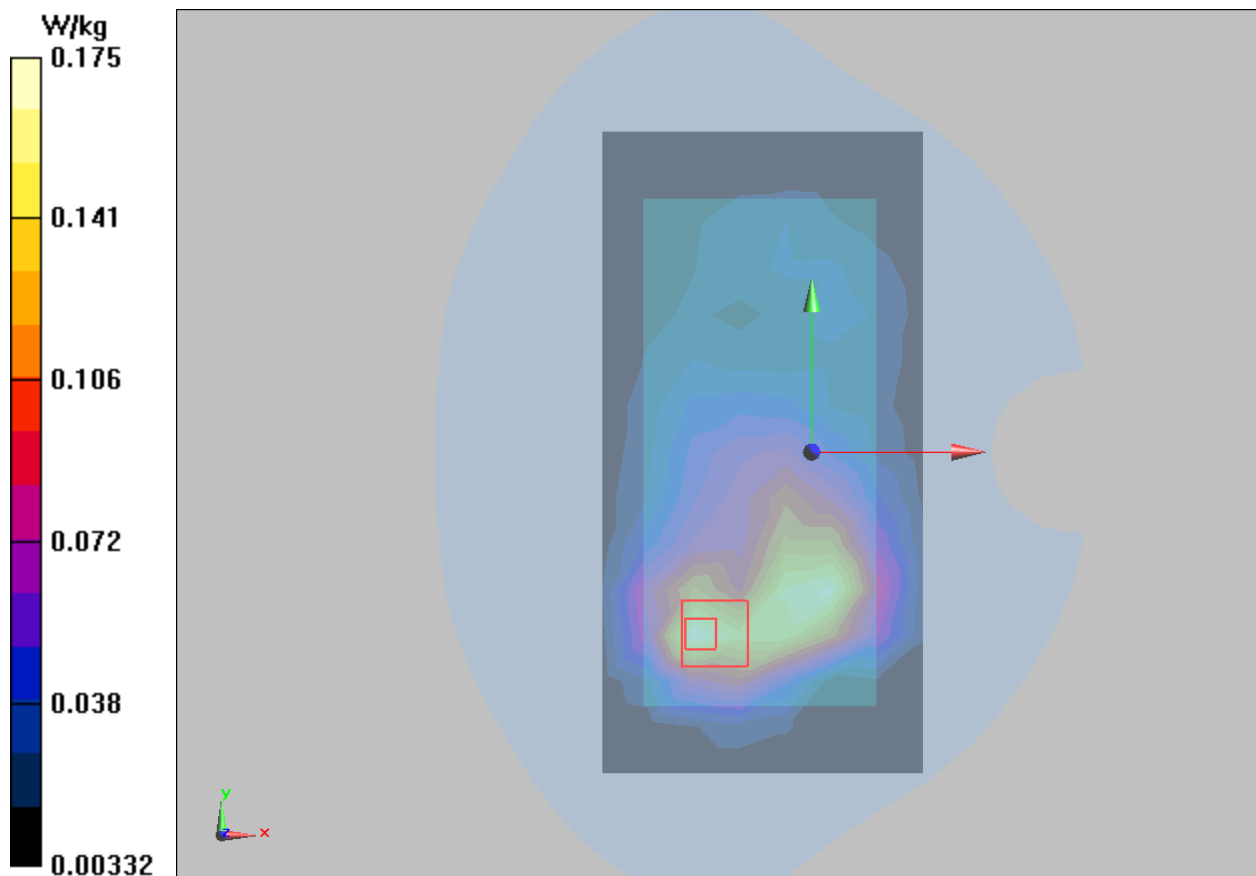

Plot 20 LTE Band 4 1RB Left Cheek Middle

Date: 9/22/2020

Communication System: UID 0, LTE (0); Frequency: 1732.5 MHz; Duty Cycle: 1:1

Medium parameters used (interpolated): $f = 1732.5$ MHz; $\sigma = 1.293$ S/m; $\epsilon_r = 38.785$; $\rho = 1000$ kg/m³

Ambient Temperature: 22.3 °C Liquid Temperature: 21.5 °C

Phantom section: Left Section

DASY5 Configuration:

Sensor-Surface: 1.4mm (Mechanical Surface Detection)

Probe: EX3DV4 - SN3677; ConvF(8.25, 8.25, 8.25); Calibrated: 7/6/2020;

Electronics: DAE4 SN1317; Calibrated: 10/23/2019

Phantom: SAM1; Type: SAM; Serial: TP-1534

Measurement SW: DASY52, Version 52.10 (1); SEMCAD X Version 14.6.11 (7439)

Left Cheek Middle /Area Scan (8x14x1): Measurement grid: dx=15mm, dy=15mm

Maximum value of SAR (measured) = 0.132 W/kg

Left Cheek Middle /Zoom Scan (5x5x7)/Cube 0: Measurement grid: dx=8mm, dy=8mm, dz=5mm

Reference Value = 3.150 V/m; Power Drift = 0.037 dB

Peak SAR (extrapolated) = 0.192 W/kg

SAR(1 g) = 0.122 W/kg; SAR(10 g) = 0.075 W/kg

Maximum value of SAR (measured) = 0.131 W/kg

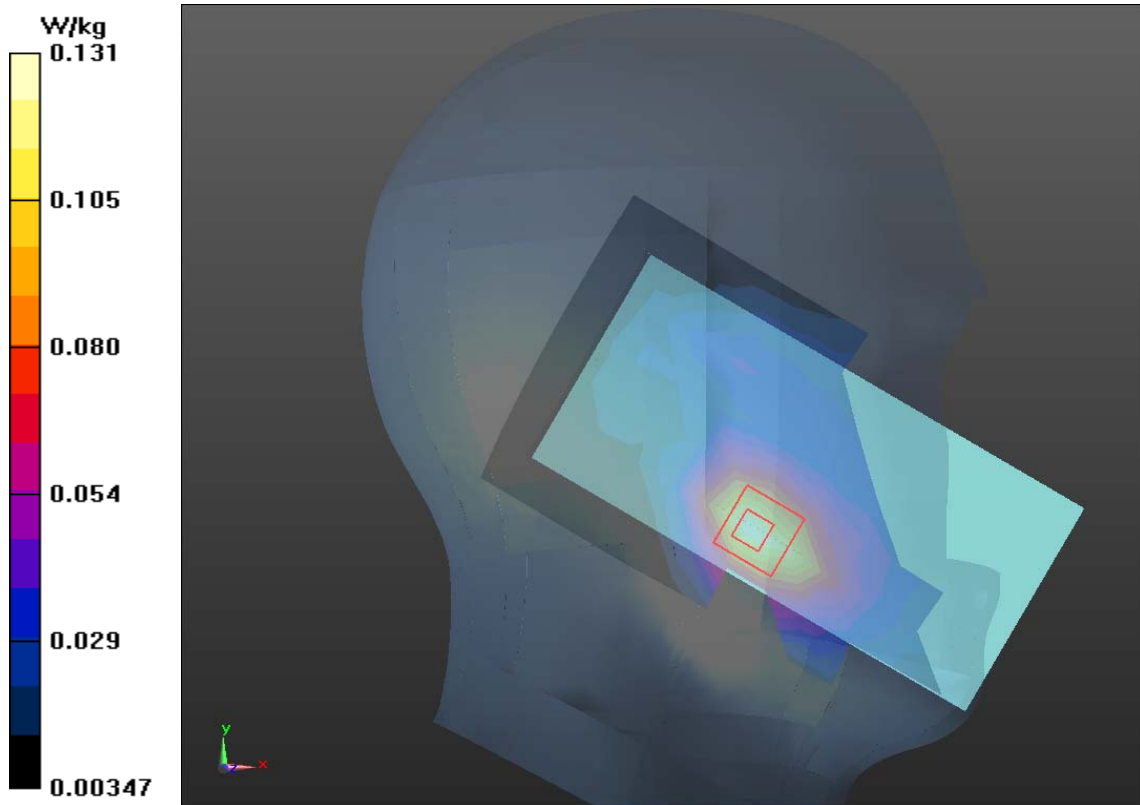

Plot 21 LTE Band 4 1RB Back Side Middle (Distance 15mm)

Date: 9/22/2020

Communication System: UID 0, LTE (0); Frequency: 1732.5 MHz; Duty Cycle: 1:1

Medium parameters used (interpolated): $f = 1732.5$ MHz; $\sigma = 1.313$ S/m; $\epsilon_r = 39.384$; $\rho = 1000$ kg/m³

Ambient Temperature: 22.3 °C Liquid Temperature: 21.5 °C

Phantom section: Flat Section

DASY5 Configuration:

Sensor-Surface: 1.4mm (Mechanical Surface Detection)

Probe: EX3DV4 - SN3677; ConvF(8.25, 8.25, 8.25); Calibrated: 7/6/2020;

Electronics: DAE4 SN1317; Calibrated: 10/23/2019

Phantom: SAM1; Type: SAM; Serial: TP-1534

Measurement SW: DASY52, Version 52.10 (1); SEMCAD X Version 14.6.11 (7439)

Back Side Middle /Area Scan (8x15x1): Measurement grid: dx=15mm, dy=15mm

Maximum value of SAR (measured) = 0.555 W/kg

Back Side Middle /Zoom Scan (5x5x7)/Cube 0: Measurement grid: dx=8mm, dy=8mm, dz=5mm

Reference Value = 10.68 V/m; Power Drift = -0.02 dB

Peak SAR (extrapolated) = 0.915 W/kg

SAR(1 g) = 0.576 W/kg; SAR(10 g) = 0.338 W/kg

Maximum value of SAR (measured) = 0.636 W/kg

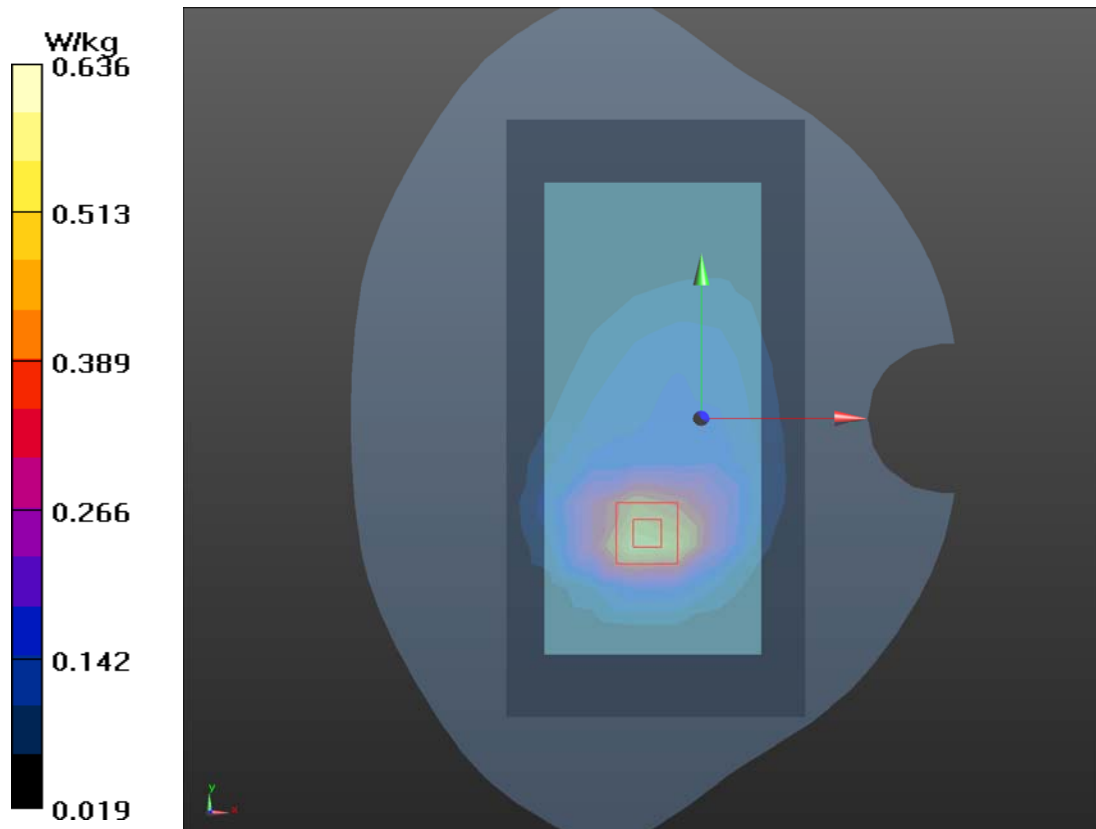

Plot 22 LTE Band 4 1RB Bottom Edge Middle (Distance 10mm)

Date: 9/22/2020

Communication System: UID 0, LTE (0); Frequency: 1732.5 MHz; Duty Cycle: 1:1

Medium parameters used (interpolated): $f = 1732.5$ MHz; $\sigma = 1.313$ S/m; $\epsilon_r = 39.384$; $\rho = 1000$ kg/m³

Ambient Temperature: 22.3 °C Liquid Temperature: 21.5 °C

Phantom section: Flat Section

DASY5 Configuration:

Sensor-Surface: 1.4mm (Mechanical Surface Detection)

Probe: EX3DV4 - SN3677; ConvF(8.25, 8.25, 8.25); Calibrated: 7/6/2020;

Electronics: DAE4 SN1317; Calibrated: 10/23/2019

Phantom: SAM1; Type: SAM; Serial: TP-1534

Measurement SW: DASY52, Version 52.10 (1); SEMCAD X Version 14.6.11 (7439)

Bottom Edge Middle /Area Scan (4x8x1): Measurement grid: dx=15mm, dy=15mm

Maximum value of SAR (measured) = 1.09 W/kg

Bottom Edge Middle/Zoom Scan (5x5x7)/Cube 0: Measurement grid: dx=8mm, dy=8mm, dz=5mm

Reference Value = 22.54 V/m; Power Drift = 0.050 dB

Peak SAR (extrapolated) = 1.87 W/kg

SAR(1 g) = 1.06 W/kg; SAR(10 g) = 0.564 W/kg

Maximum value of SAR (measured) = 1.17 W/kg

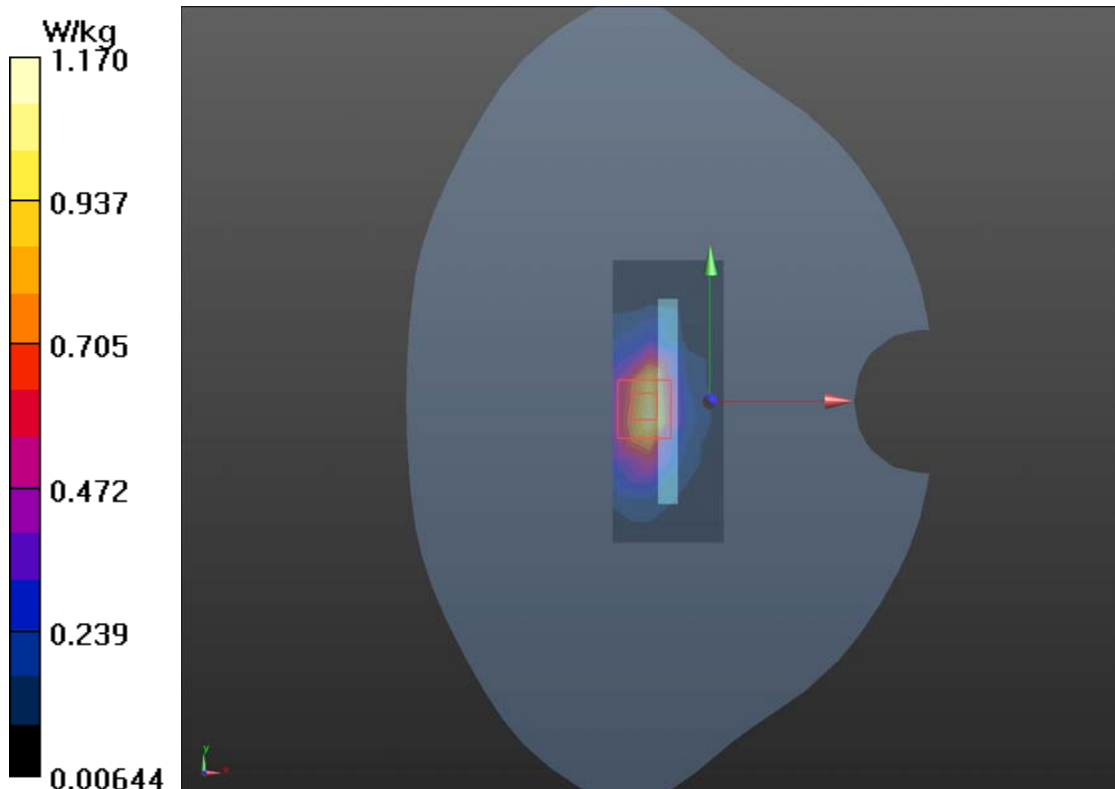

Plot 23 LTE Band 4 1RB Bottom Edge High (Distance 0mm)

Date: 9/22/2020

Communication System: UID 0, LTE (0); Frequency: 1745 MHz; Duty Cycle: 1:1

Medium parameters used: $f = 1745$ MHz; $\sigma = 1.323$ S/m; $\epsilon_r = 39.378$; $\rho = 1000$ kg/m³

Ambient Temperature: 22.3 °C Liquid Temperature: 21.5 °C

Phantom section: Flat Section

DASY5 Configuration:

Sensor-Surface: 1.4mm (Mechanical Surface Detection)

Probe: EX3DV4 - SN3677; ConvF(8.25, 8.25, 8.25); Calibrated: 7/6/2020;

Electronics: DAE4 SN1317; Calibrated: 10/23/2019

Phantom: SAM1; Type: SAM; Serial: TP-1534

Measurement SW: DASY52, Version 52.10 (1); SEMCAD X Version 14.6.11 (7439)

Bottom Edge High/Area Scan (4x8x1): Measurement grid: dx=15mm, dy=15mm

Maximum value of SAR (measured) = 6.44 W/kg

Bottom Edge High/Zoom Scan (5x5x7)/Cube 0: Measurement grid: dx=8mm, dy=8mm, dz=5mm

Reference Value = 49.59 V/m; Power Drift = 0.061 dB

Peak SAR (extrapolated) = 13.8 W/kg

SAR(1 g) = 5.8 W/kg; SAR(10 g) = 2.47 W/kg

Maximum value of SAR (measured) = 6.19 W/kg

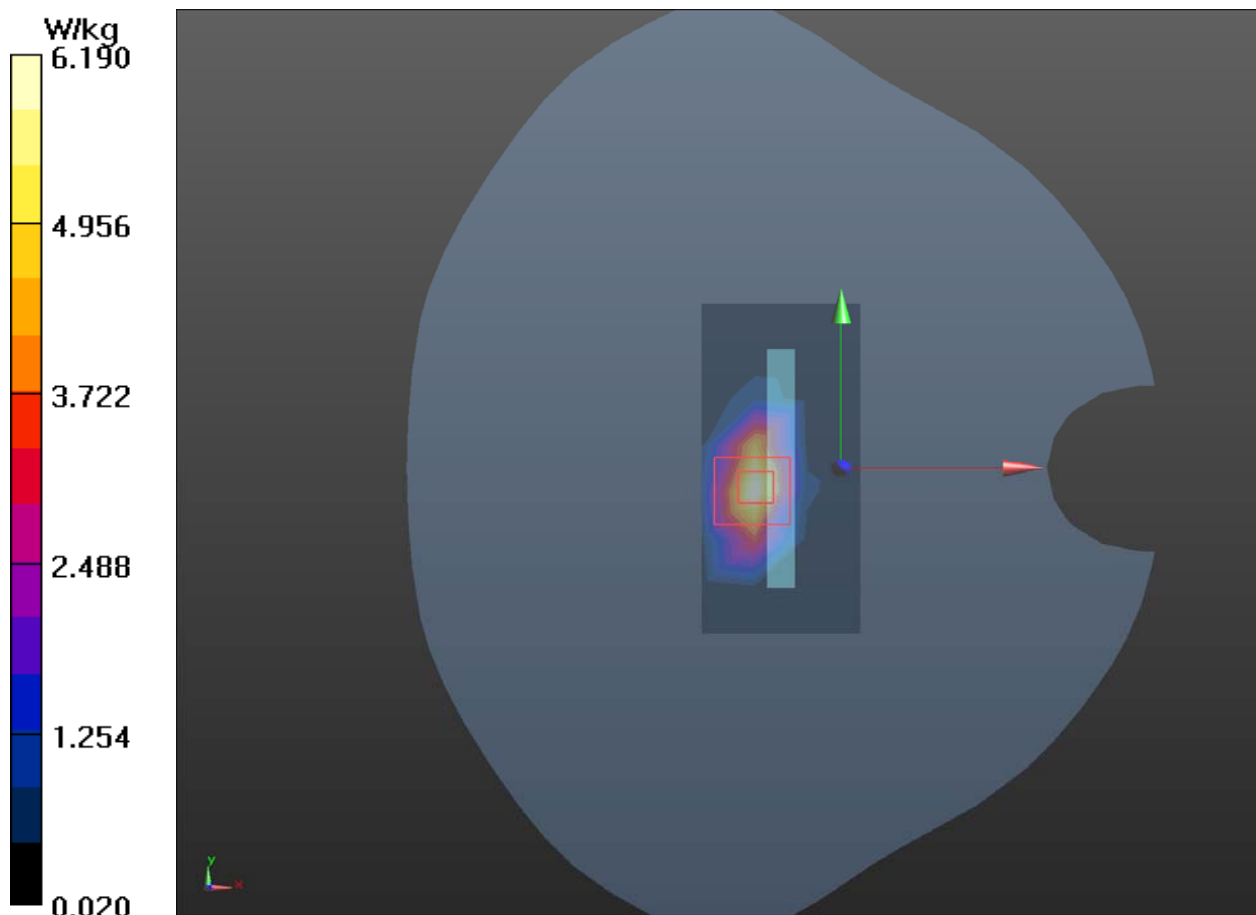

Plot 24 LTE Band 5 1RB Right Cheek High

Date: 10/15/2020

Communication System: UID 0, LTE (0); Frequency: 844 MHz; Duty Cycle: 1:1

Medium parameters used: $f = 844$ MHz; $\sigma = 0.928$ S/m; $\epsilon_r = 42.206$; $\rho = 1000$ kg/m³

Ambient Temperature: 22.3 °C Liquid Temperature: 21.5 °C

Phantom section: Right Section

DASY5 Configuration:

Sensor-Surface: 1.4mm (Mechanical Surface Detection)

Probe: EX3DV4 - SN3677; ConvF(9.38, 9.38, 9.38); Calibrated: 7/6/2020;

Electronics: DAE4 SN1317; Calibrated: 10/23/2019

Phantom: SAM1; Type: SAM; Serial: TP-1534

Measurement SW: DASY52, Version 52.10 (1); SEMCAD X Version 14.6.11 (7439)

Right Cheek High/Area Scan (8x14x1): Measurement grid: dx=15mm, dy=15mm

Maximum value of SAR (measured) = 1.45 W/kg

Right Cheek High/Zoom Scan (5x5x7)/Cube 0: Measurement grid: dx=8mm, dy=8mm, dz=5mm

Reference Value = 29.56 V/m; Power Drift = 0.03 dB

Peak SAR (extrapolated) = 2.53 W/kg

SAR(1 g) = 1.29 W/kg; SAR(10 g) = 0.730 W/kg

Maximum value of SAR (measured) = 1.42 W/kg

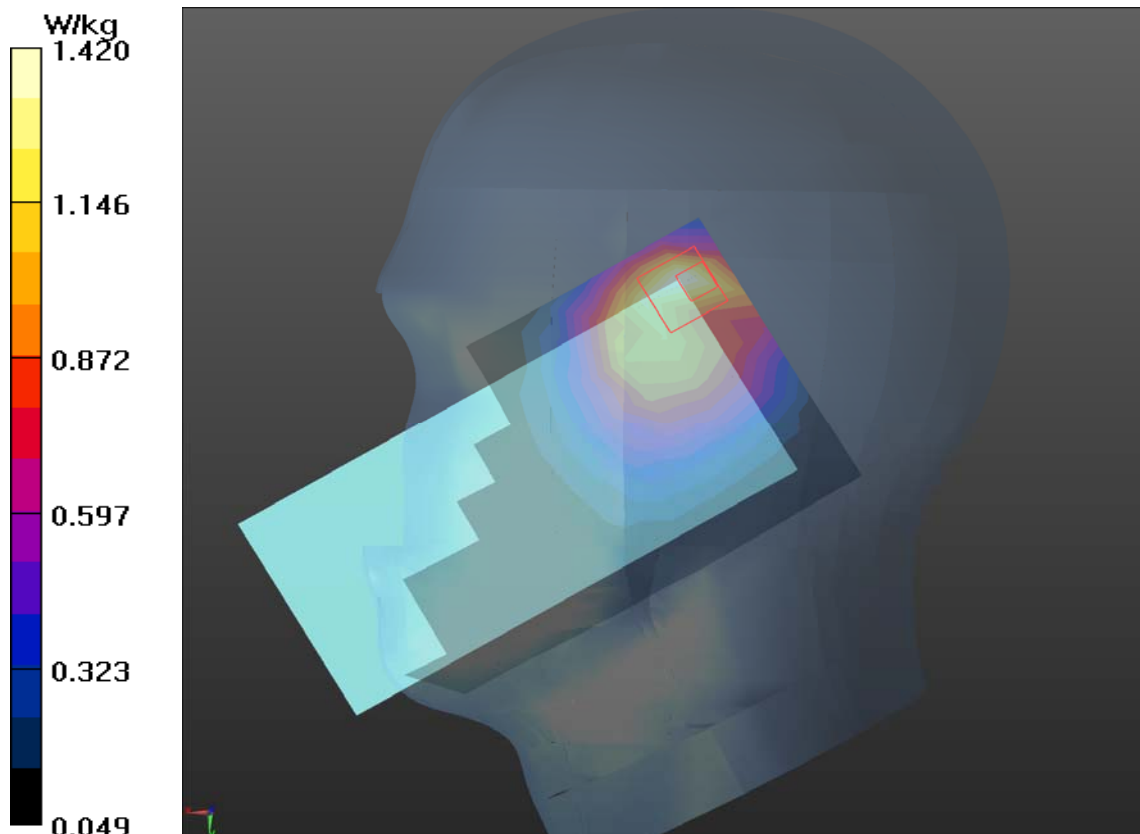

Plot 25 LTE Band 5 1RB Back Side High(Distance 15mm)

Date: 10/16/2020

Communication System: UID 0, LTE (0); Frequency: 844 MHz;Duty Cycle: 1:1

Medium parameters used: $f = 844 \text{ MHz}$; $\sigma = 0.928 \text{ S/m}$; $\epsilon_r = 42.206$; $\rho = 1000 \text{ kg/m}^3$

Ambient Temperature:22.3 °C Liquid Temperature: 21.5°C

Phantom section: Flat Section

DASY5 Configuration:

Sensor-Surface: 1.4mm (Mechanical Surface Detection)

Probe: EX3DV4 - SN3677; ConvF(9.38, 9.38, 9.38); Calibrated:7/6/2020;

Electronics: DAE4 SN1317; Calibrated: 10/23/2019

Phantom: SAM1; Type: SAM; Serial: TP-1534

Measurement SW: DASY52, Version 52.10 (1); SEMCAD X Version 14.6.11 (7439)

Back Side High/Area Scan (8x15x1): Measurement grid: dx=15mm, dy=15mm

Maximum value of SAR (measured) = 0.543 W/kg

Back Side High/Zoom Scan (5x5x7)/Cube 0: Measurement grid: dx=8mm, dy=8mm, dz=5mm

Reference Value = 13.19 V/m; Power Drift = 0.10 dB

Peak SAR (extrapolated) = 0.794 W/kg

SAR(1 g) = 0.513 W/kg; SAR(10 g) = 0.343 W/kg

Maximum value of SAR (measured) = 0.551 W/kg

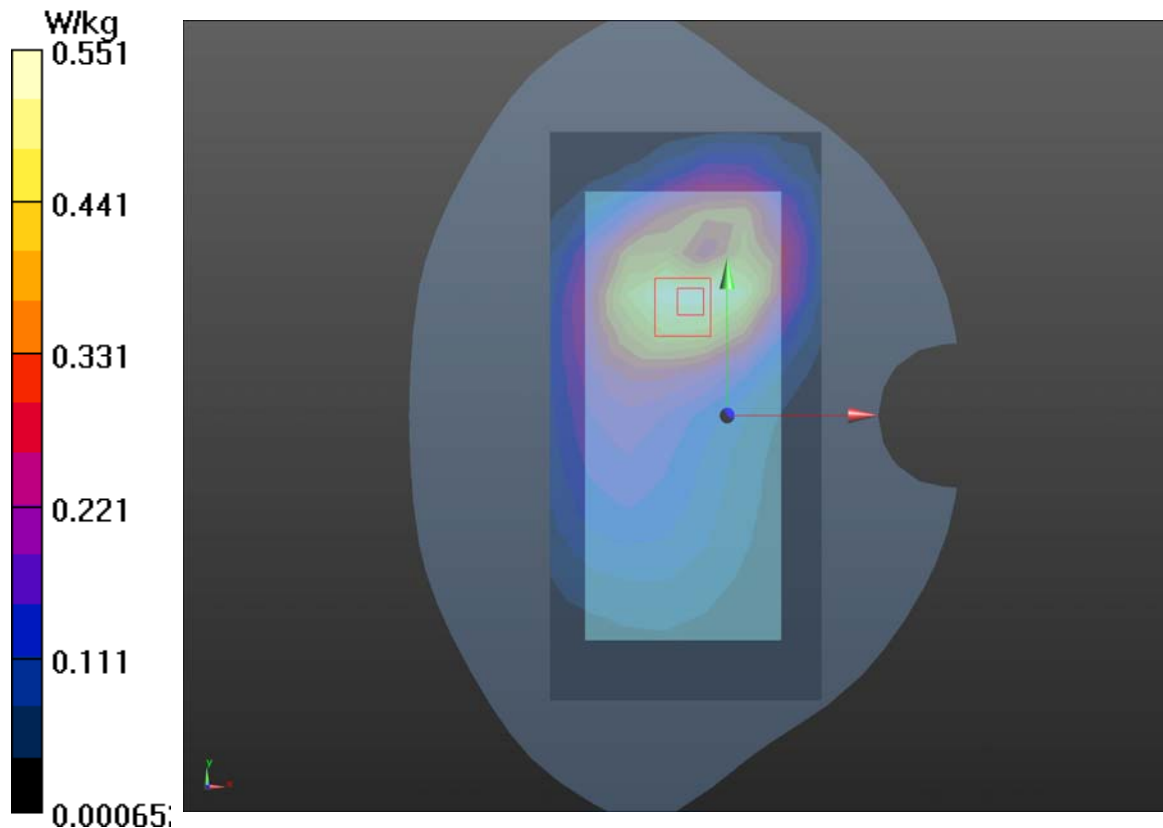

Plot 26 LTE Band 5 1RB Back Side High (Distance 10mm)

Date: 10/16/2020

Communication System: UID 0, LTE (0); Frequency: 844 MHz; Duty Cycle: 1:1

Medium parameters used: $f = 844 \text{ MHz}$; $\sigma = 0.928 \text{ S/m}$; $\epsilon_r = 42.206$; $\rho = 1000 \text{ kg/m}^3$

Ambient Temperature: $22.3 \text{ }^\circ\text{C}$ Liquid Temperature: $21.5 \text{ }^\circ\text{C}$

Phantom section: Flat Section

DASY5 Configuration:

Sensor-Surface: 1.4mm (Mechanical Surface Detection)

Probe: EX3DV4 - SN3677; ConvF(9.38, 9.38, 9.38); Calibrated: 7/6/2020;

Electronics: DAE4 SN1317; Calibrated: 10/23/2019

Phantom: SAM1; Type: SAM; Serial: TP-1534

Measurement SW: DASY52, Version 52.10 (1); SEMCAD X Version 14.6.11 (7439)

Back Side High/Area Scan (8x15x1): Measurement grid: $dx=15\text{mm}$, $dy=15\text{mm}$

Maximum value of SAR (measured) = 0.668 W/kg

Back Side High/Zoom Scan (5x5x7)/Cube 0: Measurement grid: $dx=8\text{mm}$, $dy=8\text{mm}$, $dz=5\text{mm}$

Reference Value = 16.51 V/m ; Power Drift = -0.028 dB

Peak SAR (extrapolated) = 1.00 W/kg

SAR(1 g) = 0.609 W/kg ; SAR(10 g) = 0.378 W/kg .

Maximum value of SAR (measured) = 0.664 W/kg

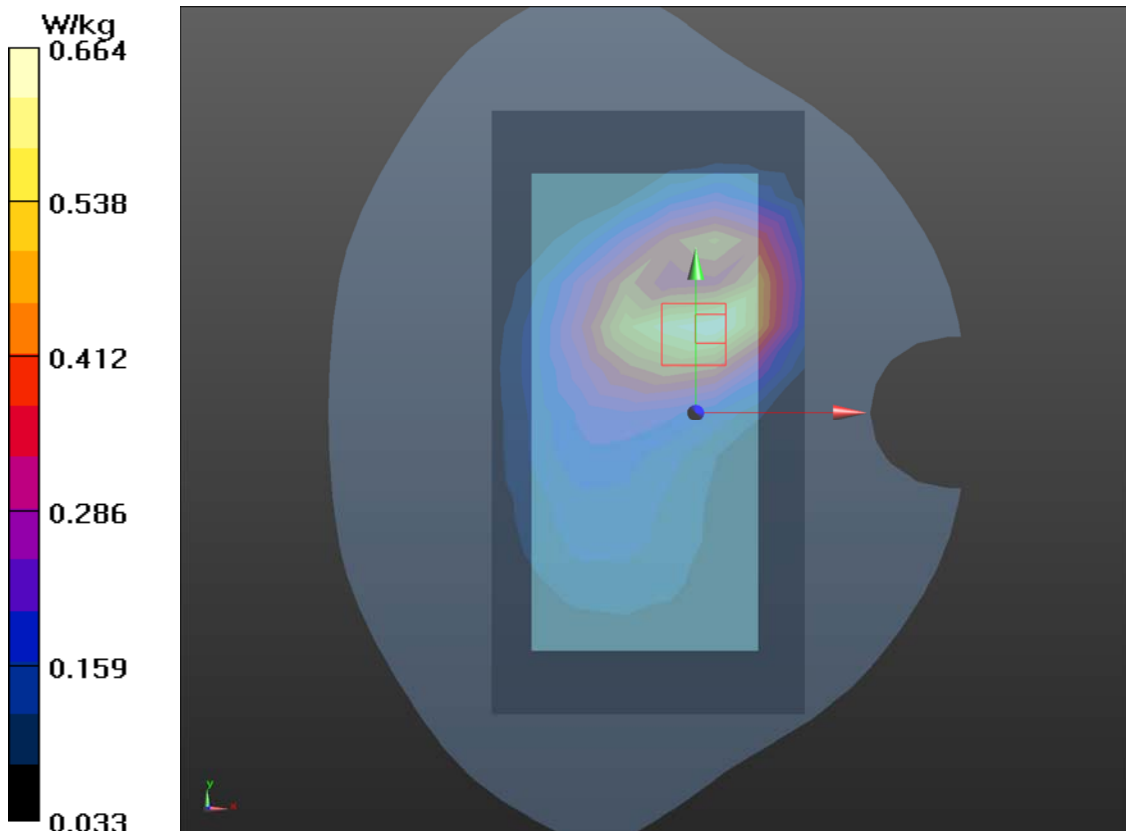

Plot 27 LTE Band 12 50%RB Right Cheek Middle

Date: 8/25/2020

Communication System: UID 0, LTE (0); Frequency: 707.5 MHz; Duty Cycle: 1:1

Medium parameters used (interpolated): $f = 707.5$ MHz; $\sigma = 0.848$ S/m; $\epsilon_r = 42.763$; $\rho = 1000$ kg/m³

Ambient Temperature: 22.3 °C Liquid Temperature: 21.5 °C

Phantom section: Right Section

DASY5 Configuration:

Sensor-Surface: 1.4mm (Mechanical Surface Detection)

Probe: EX3DV4 - SN3677; ConvF(9.78, 9.78, 9.78); Calibrated: 7/6/2020;

Electronics: DAE4 SN1317; Calibrated: 10/23/2019

Phantom: SAM1; Type: SAM; Serial: TP-1534

Measurement SW: DASY52, Version 52.10 (1); SEMCAD X Version 14.6.11 (7439)

Right Cheek Middle/Area Scan (8x14x1): Measurement grid: dx=15mm, dy=15mm

Maximum value of SAR (measured) = 0.153 W/kg

Right Cheek Middle/Zoom Scan (5x5x7)/Cube 0: Measurement grid: dx=8mm, dy=8mm, dz=5mm

Reference Value = 10.83 V/m; Power Drift = 0.07 dB

Peak SAR (extrapolated) = 0.315 W/kg

SAR(1 g) = 0.154 W/kg; SAR(10 g) = 0.097 W/kg

Maximum value of SAR (measured) = 0.166 W/kg

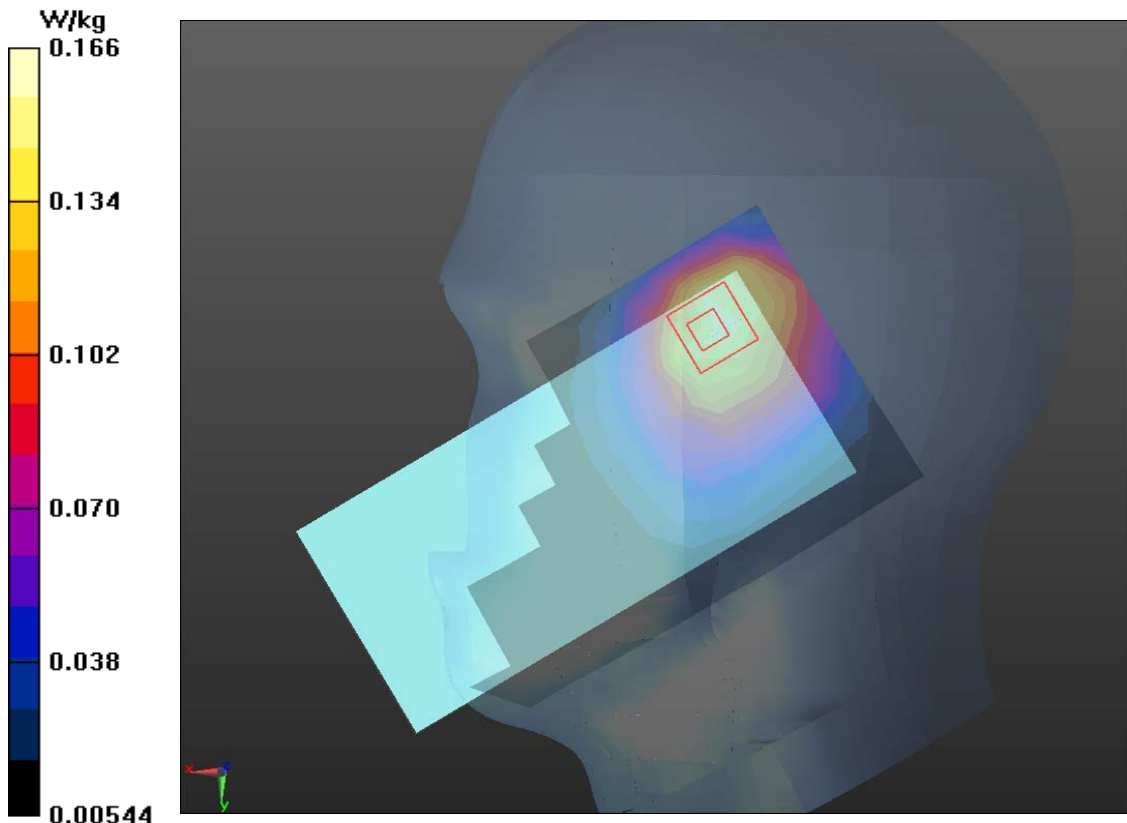

Plot 28 LTE Band 12 1RB Back Side High(Distance 15mm)

Date: 8/25/2020

Communication System: UID 0, LTE (0); Frequency: 711 MHz;Duty Cycle: 1:1

Medium parameters used: $f = 711$ MHz; $\sigma = 0.85$ S/m; $\epsilon_r = 42.755$; $\rho = 1000$ kg/m³

Ambient Temperature:22.3 °C Liquid Temperature: 21.5°C

Phantom section: Flat Section

DASY5 Configuration:

Sensor-Surface: 1.4mm (Mechanical Surface Detection)

Probe: EX3DV4 - SN3677; ConvF(9.78, 9.78, 9.78); Calibrated:7/6/2020;

Electronics: DAE4 SN1317; Calibrated: 10/23/2019

Phantom: SAM1; Type: SAM; Serial: TP-1534

Measurement SW: DASY52, Version 52.10 (1); SEMCAD X Version 14.6.11 (7439)

Back Side High/Area Scan (8x15x1): Measurement grid: dx=15mm, dy=15mm

Maximum value of SAR (measured) = 0.0531 W/kg

Back Side High/Zoom Scan (5x5x7)/Cube 0: Measurement grid: dx=8mm, dy=8mm, dz=5mm

Reference Value = 7.395 V/m; Power Drift = -0.16 dB

Peak SAR (extrapolated) = 0.0720 W/kg

SAR(1 g) = 0.060 W/kg; SAR(10 g) = 0.040 W/kg

Maximum value of SAR (measured) = 0.071 W/kg

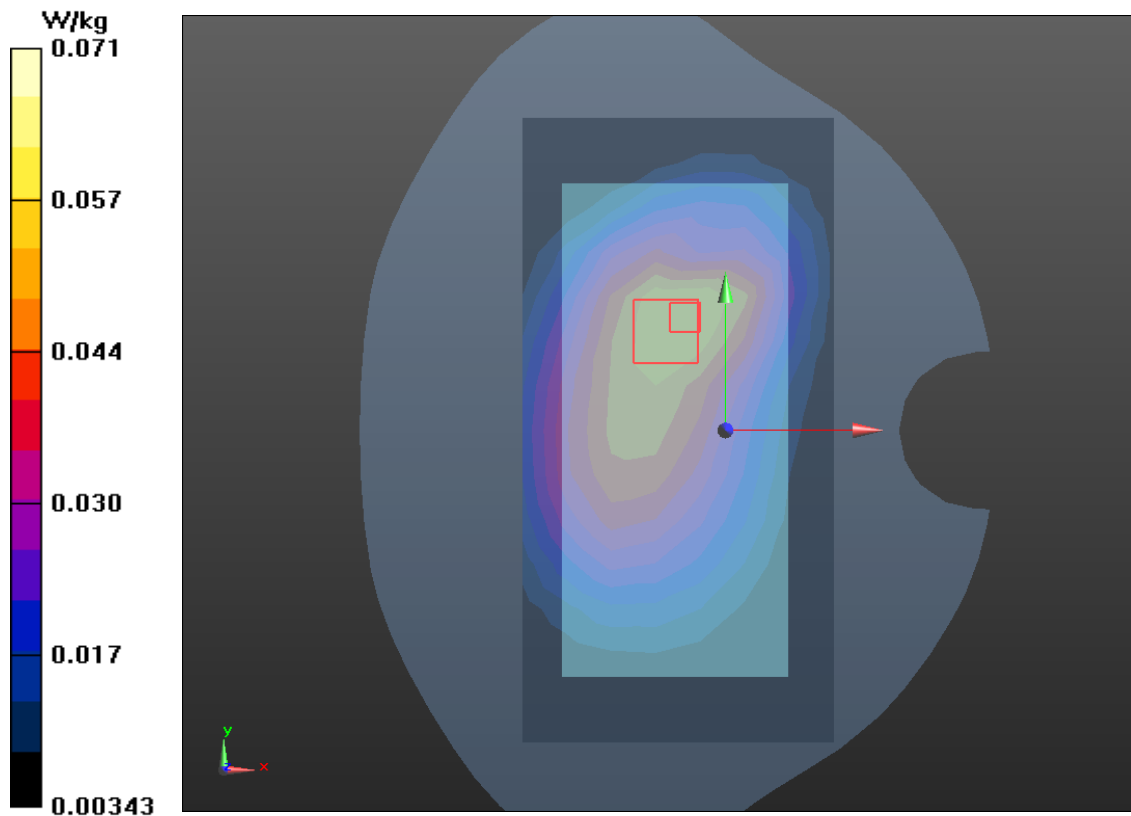

Plot 29 LTE Band 12 1RB Back Side High (Distance 10mm)

Date: 8/25/2020

Communication System: UID 0, LTE (0); Frequency: 711 MHz; Duty Cycle: 1:1

Medium parameters used: $f = 711 \text{ MHz}$; $\sigma = 0.85 \text{ S/m}$; $\epsilon_r = 42.755$; $\rho = 1000 \text{ kg/m}^3$

Ambient Temperature: $22.3 \text{ }^\circ\text{C}$ Liquid Temperature: $21.5 \text{ }^\circ\text{C}$

Phantom section: Flat Section

DASY5 Configuration:

Sensor-Surface: 1.4mm (Mechanical Surface Detection)

Probe: EX3DV4 - SN3677; ConvF(9.78, 9.78, 9.78); Calibrated: 7/6/2020;

Electronics: DAE4 SN1317; Calibrated: 10/23/2019

Phantom: SAM1; Type: SAM; Serial: TP-1534

Measurement SW: DASY52, Version 52.10 (1); SEMCAD X Version 14.6.11 (7439)

Back Side High/Area Scan (8x15x1): Measurement grid: $dx=15\text{mm}$, $dy=15\text{mm}$

Maximum value of SAR (measured) = 0.0954 W/kg

Back Side High/Zoom Scan (5x5x7)/Cube 0: Measurement grid: $dx=8\text{mm}$, $dy=8\text{mm}$, $dz=5\text{mm}$

Reference Value = 7.376 V/m ; Power Drift = 0.09 dB

Peak SAR (extrapolated) = 0.140 W/kg

SAR(1 g) = 0.089 W/kg ; SAR(10 g) = 0.060 W/kg

Maximum value of SAR (measured) = 0.095 W/kg

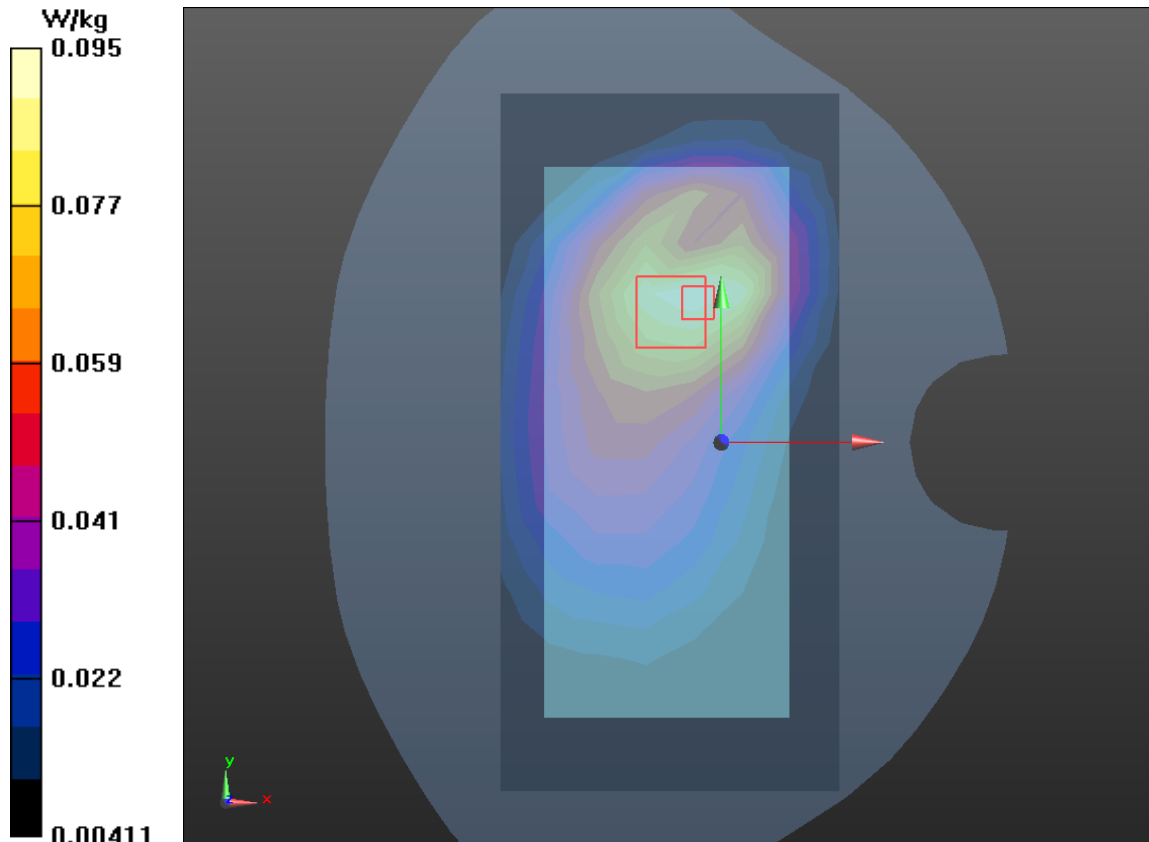

Plot 30 LTE Band 13 100%RB Right Cheek Middle

Date: 8/25/2020

Communication System: UID 0, LTE (0); Frequency: 782 MHz; Duty Cycle: 1:1

Medium parameters used: $f = 782 \text{ MHz}$; $\sigma = 0.887 \text{ S/m}$; $\epsilon_r = 42.079$; $\rho = 1000 \text{ kg/m}^3$ Ambient Temperature: $22.3 \text{ }^\circ\text{C}$ Liquid Temperature: $21.5 \text{ }^\circ\text{C}$

Phantom section: Right Section

DASY5 Configuration:

Sensor-Surface: 1.4mm (Mechanical Surface Detection)

Probe: EX3DV4 - SN3677; ConvF(9.78, 9.78, 9.78); Calibrated: 7/6/2020;

Electronics: DAE4 SN1317; Calibrated: 10/23/2019

Phantom: SAM1; Type: SAM; Serial: TP-1534

Measurement SW: DASY52, Version 52.10 (1); SEMCAD X Version 14.6.11 (7439)

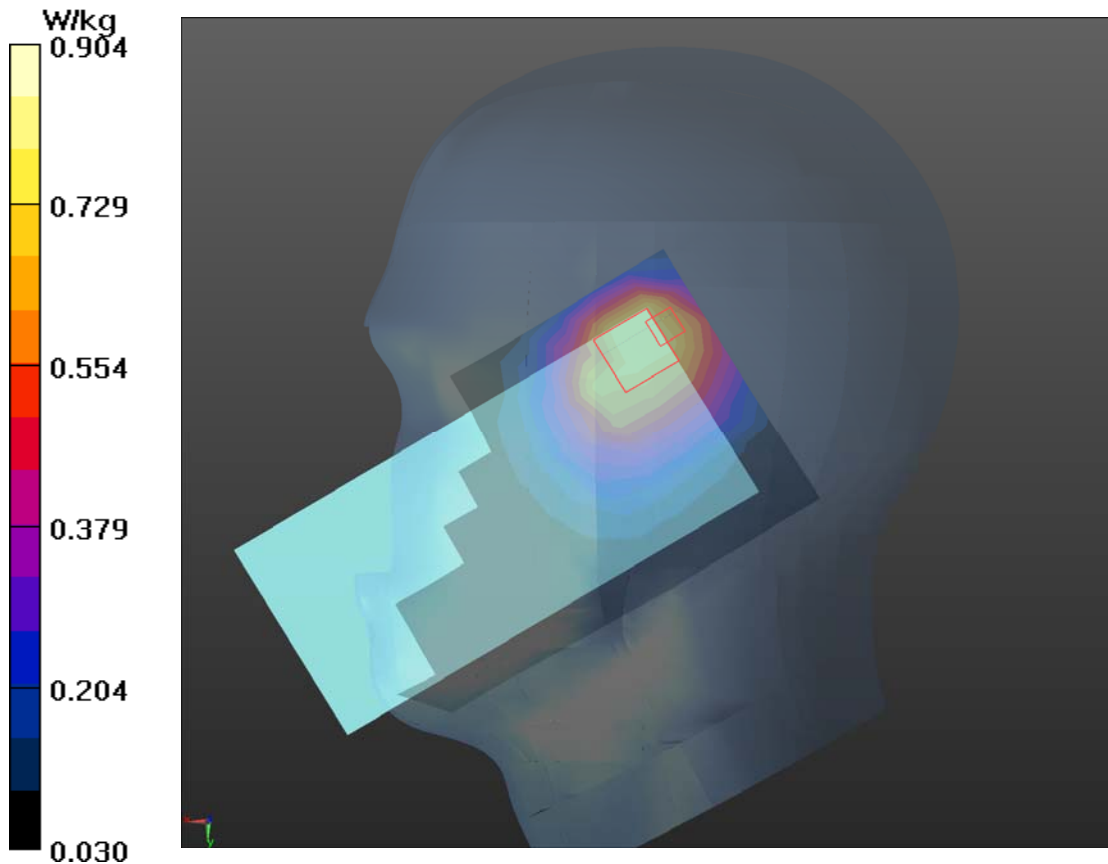
Right Cheek Middle/Area Scan (8x14x1): Measurement grid: $dx=15\text{mm}$, $dy=15\text{mm}$ Maximum value of SAR (measured) = 0.770 W/kg **Right Cheek Middle/Zoom Scan (5x5x7)/Cube 0:** Measurement grid: $dx=8\text{mm}$, $dy=8\text{mm}$, $dz=5\text{mm}$ Reference Value = 22.87 V/m ; Power Drift = 0.06 dB Peak SAR (extrapolated) = 1.63 W/kg **SAR(1 g) = 0.816 W/kg ; SAR(10 g) = 0.483 W/kg** Maximum value of SAR (measured) = 0.904 W/kg 

Plot 31 LTE Band 13 50%RB Back Side Middle (Distance 15mm)

Date: 8/25/2020

Communication System: UID 0, LTE (0); Frequency: 782 MHz; Duty Cycle: 1:1

Medium parameters used: $f = 782 \text{ MHz}$; $\sigma = 0.887 \text{ S/m}$; $\epsilon_r = 42.079$; $\rho = 1000 \text{ kg/m}^3$ Ambient Temperature: $22.3 \text{ }^\circ\text{C}$ Liquid Temperature: $21.5 \text{ }^\circ\text{C}$

Phantom section: Flat Section

DASY5 Configuration:

Sensor-Surface: 1.4mm (Mechanical Surface Detection)

Probe: EX3DV4 - SN3677; ConvF(9.78, 9.78, 9.78); Calibrated: 7/6/2020;

Electronics: DAE4 SN1317; Calibrated: 10/23/2019

Phantom: SAM1; Type: SAM; Serial: TP-1534

Measurement SW: DASY52, Version 52.10 (1); SEMCAD X Version 14.6.11 (7439)

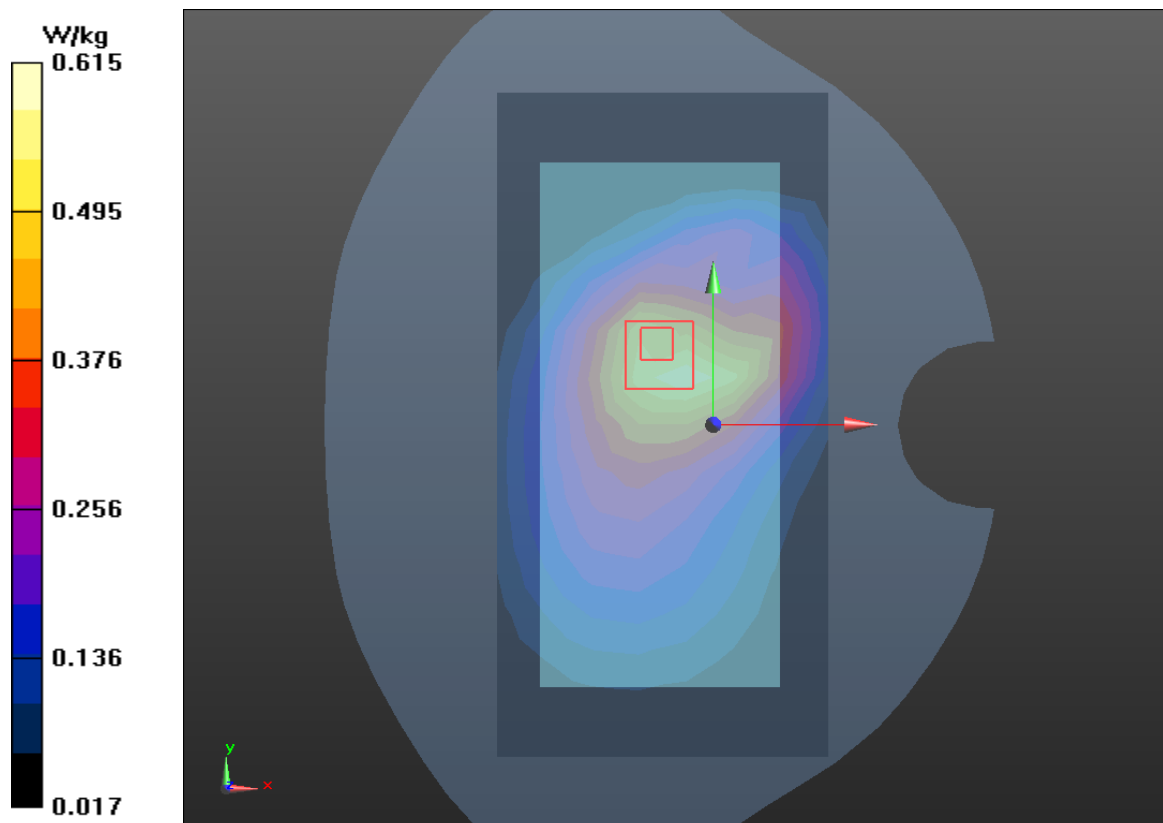
Back Side Middle /Area Scan (8x15x1): Measurement grid: $dx=15\text{mm}$, $dy=15\text{mm}$ Maximum value of SAR (measured) = 0.576 W/kg **Back Side Middle/Zoom Scan (5x5x7)/Cube 0:** Measurement grid: $dx=8\text{mm}$, $dy=8\text{mm}$, $dz=5\text{mm}$ Reference Value = 16.74 V/m ; Power Drift = 0.11 dB Peak SAR (extrapolated) = 0.715 W/kg **SAR(1 g) = 0.563 W/kg ; SAR(10 g) = 0.175 W/kg** Maximum value of SAR (measured) = 0.615 W/kg 

Plot 32 LTE Band 13 1RB Back Side Middle(Distance 10mm)

Date: 8/25/2020

Communication System: UID 0, LTE (0); Frequency: 782 MHz;Duty Cycle: 1:1

Medium parameters used: $f = 782 \text{ MHz}$; $\sigma = 0.887 \text{ S/m}$; $\epsilon_r = 42.079$; $\rho = 1000 \text{ kg/m}^3$

Ambient Temperature:22.3 °C Liquid Temperature: 21.5°C

Phantom section: Flat Section

DASY5 Configuration:

Sensor-Surface: 1.4mm (Mechanical Surface Detection)

Probe: EX3DV4 - SN3677; ConvF(9.78, 9.78, 9.78); Calibrated:7/6/2020;

Electronics: DAE4 SN1317; Calibrated: 10/23/2019

Phantom: SAM1; Type: SAM; Serial: TP-1534

Measurement SW: DASY52, Version 52.10 (1); SEMCAD X Version 14.6.11 (7439)

Back Side Middle/Area Scan (8x15x1): Measurement grid: dx=15mm, dy=15mm

Maximum value of SAR (measured) = 0.622 W/kg

Back Side Middle/Zoom Scan (5x5x7)/Cube 0: Measurement grid: dx=8mm, dy=8mm, dz=5mm

Reference Value = 14.08 V/m; Power Drift = 0.05 dB

Peak SAR (extrapolated) = 0.996 W/kg

SAR(1 g) = 0.592 W/kg; SAR(10 g) = 0.375 W/kg

Maximum value of SAR (measured) = 0.644 W/kg

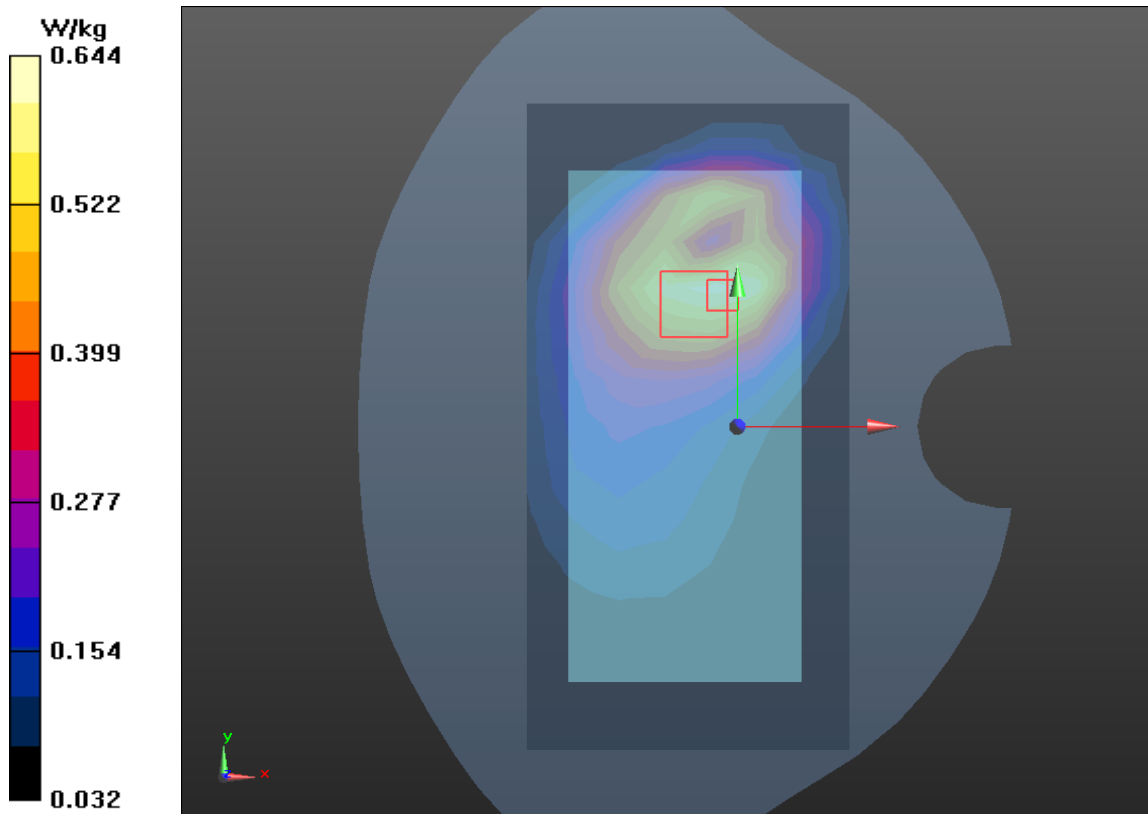

Plot 33 LTE Band 66 50%RB Left Cheek Low

Date: 9/25/2020

Communication System: UID 0, LTE (0); Frequency: 1720 MHz; Duty Cycle: 1:1

Medium parameters used: $f = 1720$ MHz; $\sigma = 1.303$ S/m; $\epsilon_r = 39.467$; $\rho = 1000$ kg/m³

Ambient Temperature: 22.3 °C Liquid Temperature: 21.5 °C

Phantom section: Left Section

DASY5 Configuration:

Sensor-Surface: 1.4mm (Mechanical Surface Detection)

Probe: EX3DV4 - SN3677; ConvF(8.25, 8.25, 8.25); Calibrated: 7/6/2020;

Electronics: DAE4 SN1317; Calibrated: 10/23/2019

Phantom: SAM1; Type: SAM; Serial: TP-1534

Measurement SW: DASY52, Version 52.10 (1); SEMCAD X Version 14.6.11 (7439)

Left Cheek Low/Area Scan (8x14x1): Measurement grid: dx=15mm, dy=15mm

Maximum value of SAR (measured) = 0.0648 W/kg

Left Cheek Low/Zoom Scan (5x5x7)/Cube 0: Measurement grid: dx=8mm, dy=8mm, dz=5mm

Reference Value = 1.278 V/m; Power Drift = 0.022 dB

Peak SAR (extrapolated) = 0.104 W/kg

SAR(1 g) = 0.058 W/kg; SAR(10 g) = 0.028 W/kg

Maximum value of SAR (measured) = 0.0660 W/kg

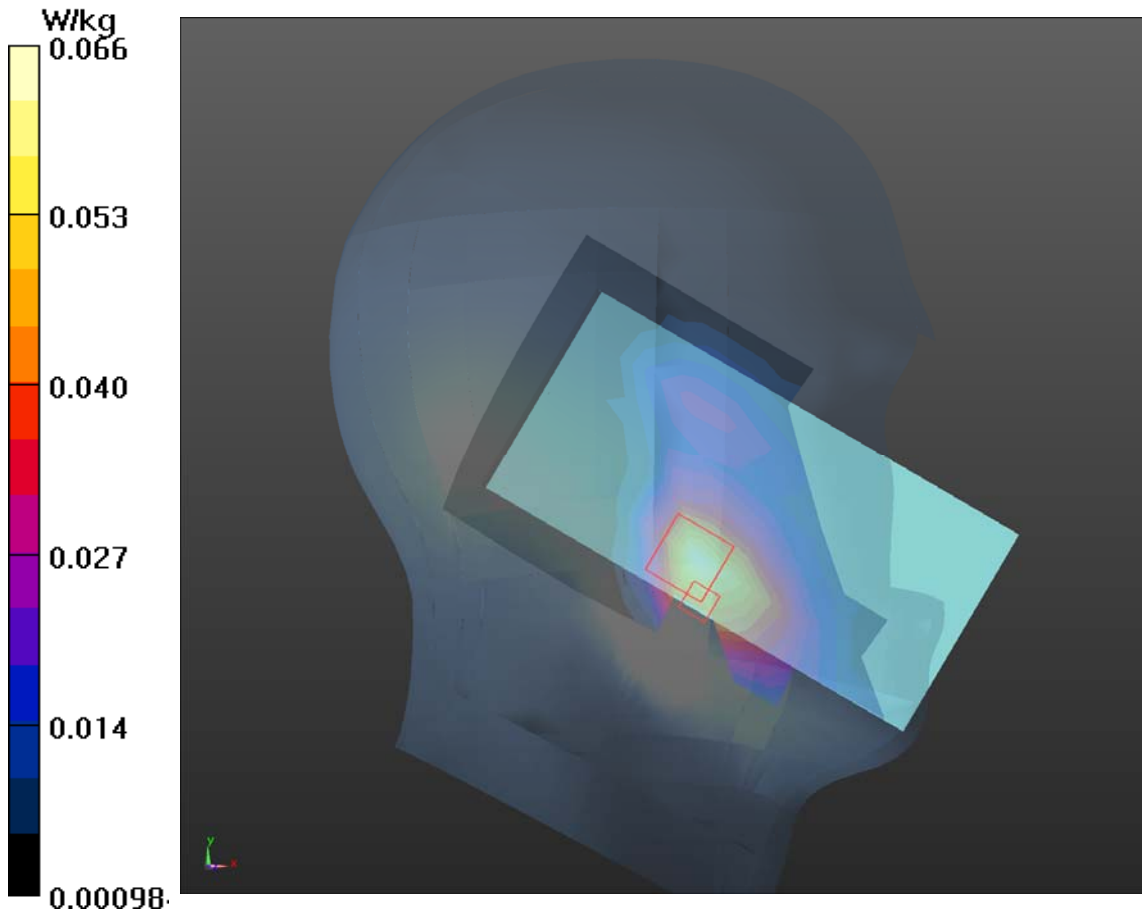

Plot 34 LTE Band 66 50%RB Back Side Low(Distance 15mm)

Date: 9/25/2020

Communication System: UID 0, LTE (0); Frequency: 1720 MHz;Duty Cycle: 1:1

Medium parameters used: $f = 1720$ MHz; $\sigma = 1.303$ S/m; $\epsilon_r = 39.467$; $\rho = 1000$ kg/m³

Ambient Temperature:22.3 °C Liquid Temperature: 21.5°C

Phantom section: Flat Section

DASY5 Configuration:

Sensor-Surface: 1.4mm (Mechanical Surface Detection)

Probe: EX3DV4 - SN3677; ConvF(8.25, 8.25, 8.25); Calibrated: 7/6/2020;

Electronics: DAE4 SN1317; Calibrated: 10/23/2019

Phantom: SAM1; Type: SAM; Serial: TP-1534

Measurement SW: DASY52, Version 52.10 (1); SEMCAD X Version 14.6.11 (7439)

Back Side Low/Area Scan (8x15x1): Measurement grid: dx=15mm, dy=15mm

Maximum value of SAR (measured) = 0.778 W/kg

Back Side Low/Zoom Scan (5x5x7)/Cube 0: Measurement grid: dx=8mm, dy=8mm, dz=5mm

Reference Value = 10.30 V/m; Power Drift = 0.05 dB

Peak SAR (extrapolated) = 1.20 W/kg

SAR(1 g) = 0.739 W/kg; SAR(10 g) = 0.424 W/kg

Maximum value of SAR (measured) = 0.811 W/kg

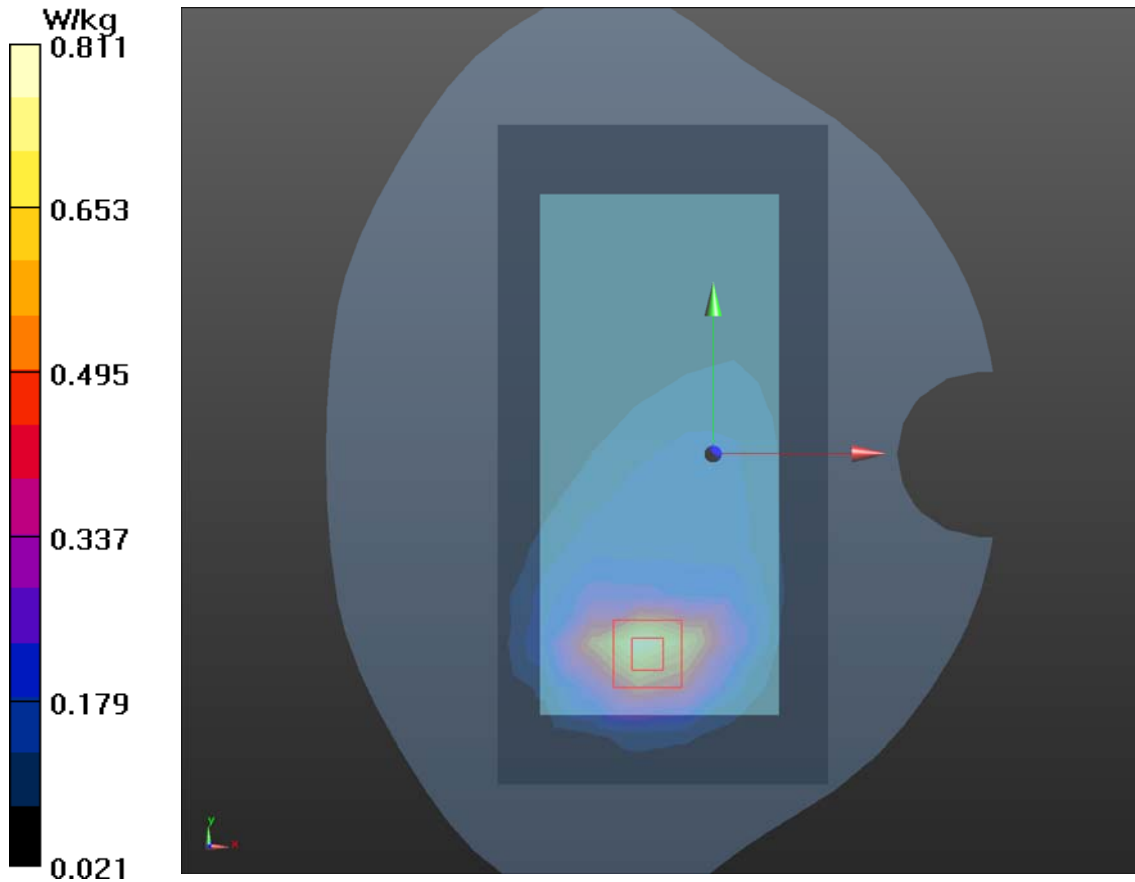

Plot 35 LTE Band 66 1RB Bottom Edge Middle (Distance 10mm)

Date: 9/25/2020

Communication System: UID 0, LTE (0); Frequency: 1745 MHz; Duty Cycle: 1:1

Medium parameters used: $f = 1745$ MHz; $\sigma = 1.323$ S/m; $\epsilon_r = 39.378$; $\rho = 1000$ kg/m³

Ambient Temperature: 22.3 °C Liquid Temperature: 21.5 °C

Phantom section: Flat Section

DASY5 Configuration:

Sensor-Surface: 1.4mm (Mechanical Surface Detection)

Probe: EX3DV4 - SN3677; ConvF(8.25, 8.25, 8.25); Calibrated: 7/6/2020;

Electronics: DAE4 SN1317; Calibrated: 10/23/2019

Phantom: SAM1; Type: SAM; Serial: TP-1534

Measurement SW: DASY52, Version 52.10 (1); SEMCAD X Version 14.6.11 (7439)

Bottom Edge Middle/Area Scan (4x8x1): Measurement grid: dx=15mm, dy=15mm

Maximum value of SAR (measured) = 1.31 W/kg

Bottom Edge Middle/Zoom Scan (5x5x7)/Cube 0: Measurement grid: dx=8mm, dy=8mm, dz=5mm

Reference Value = 30.66 V/m; Power Drift = 0.12 dB

Peak SAR (extrapolated) = 2.18 W/kg

SAR(1 g) = 1.25 W/kg; SAR(10 g) = 0.660 W/kg

Maximum value of SAR (measured) = 1.39 W/kg

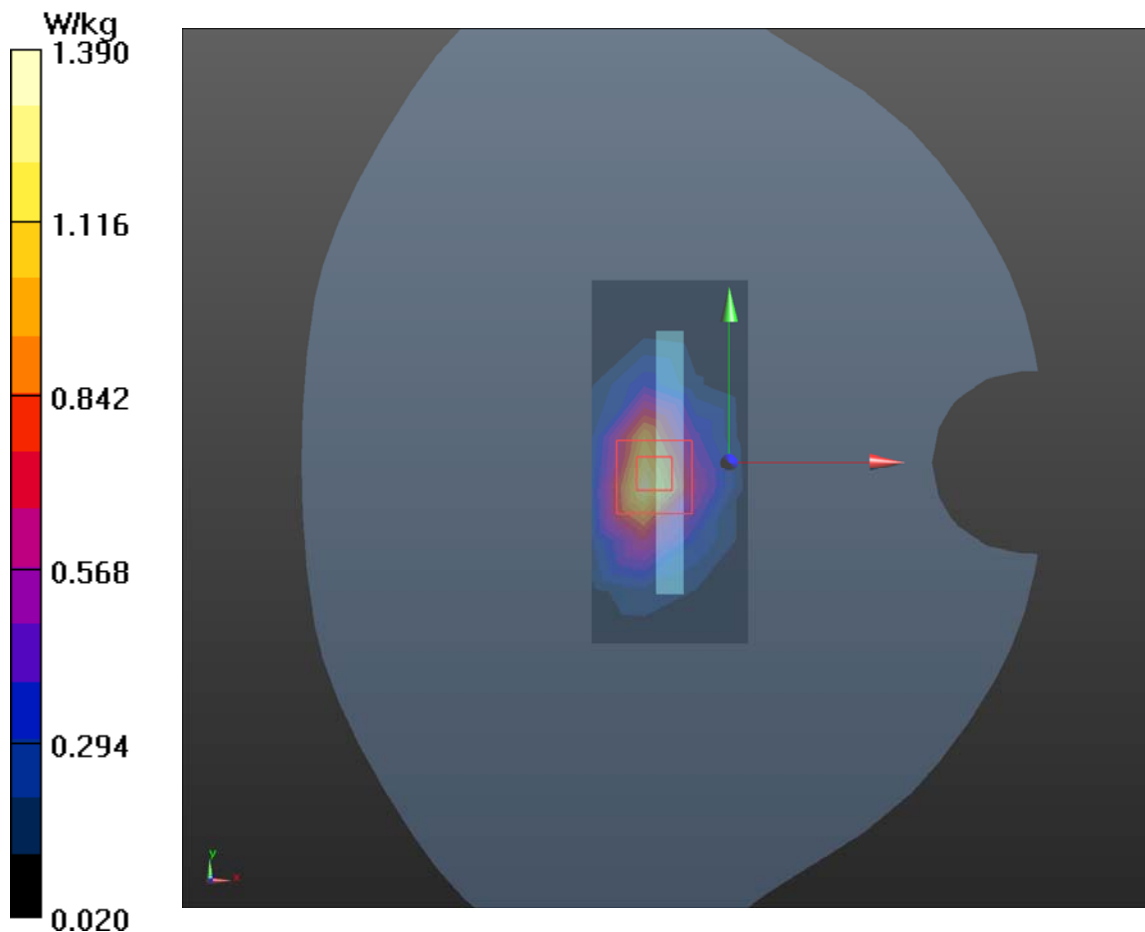

Plot 36 LTE Band 66 1RB Bottom Edge High (Distance 0mm)

Date: 9/25/2020

Communication System: UID 0, LTE (0); Frequency: 1770 MHz; Duty Cycle: 1:1

Medium parameters used: $f = 1770$ MHz; $\sigma = 1.341$ S/m; $\epsilon_r = 39.287$; $\rho = 1000$ kg/m³

Ambient Temperature: 22.3 °C Liquid Temperature: 21.5 °C

Phantom section: Flat Section

DASY5 Configuration:

Sensor-Surface: 1.4mm (Mechanical Surface Detection)

Probe: EX3DV4 - SN3677; ConvF(8.25, 8.25, 8.25); Calibrated: 7/6/2020;

Electronics: DAE4 SN1317; Calibrated: 10/23/2019

Phantom: SAM1; Type: SAM; Serial: TP-1534

Measurement SW: DASY52, Version 52.10 (1); SEMCAD X Version 14.6.11 (7439)

Bottom Edge High/Area Scan (4x8x1): Measurement grid: dx=15mm, dy=15mm

Maximum value of SAR (measured) = 8.62 W/kg

Bottom Edge High/Zoom Scan (5x5x7)/Cube 0: Measurement grid: dx=8mm, dy=8mm, dz=5mm

Reference Value = 53.04 V/m; Power Drift = 0.061 dB

Peak SAR (extrapolated) = 16.6 W/kg

SAR(1 g) = 7.42 W/kg; SAR(10 g) = 3.32 W/kg

Maximum value of SAR (measured) = 8.43 W/kg

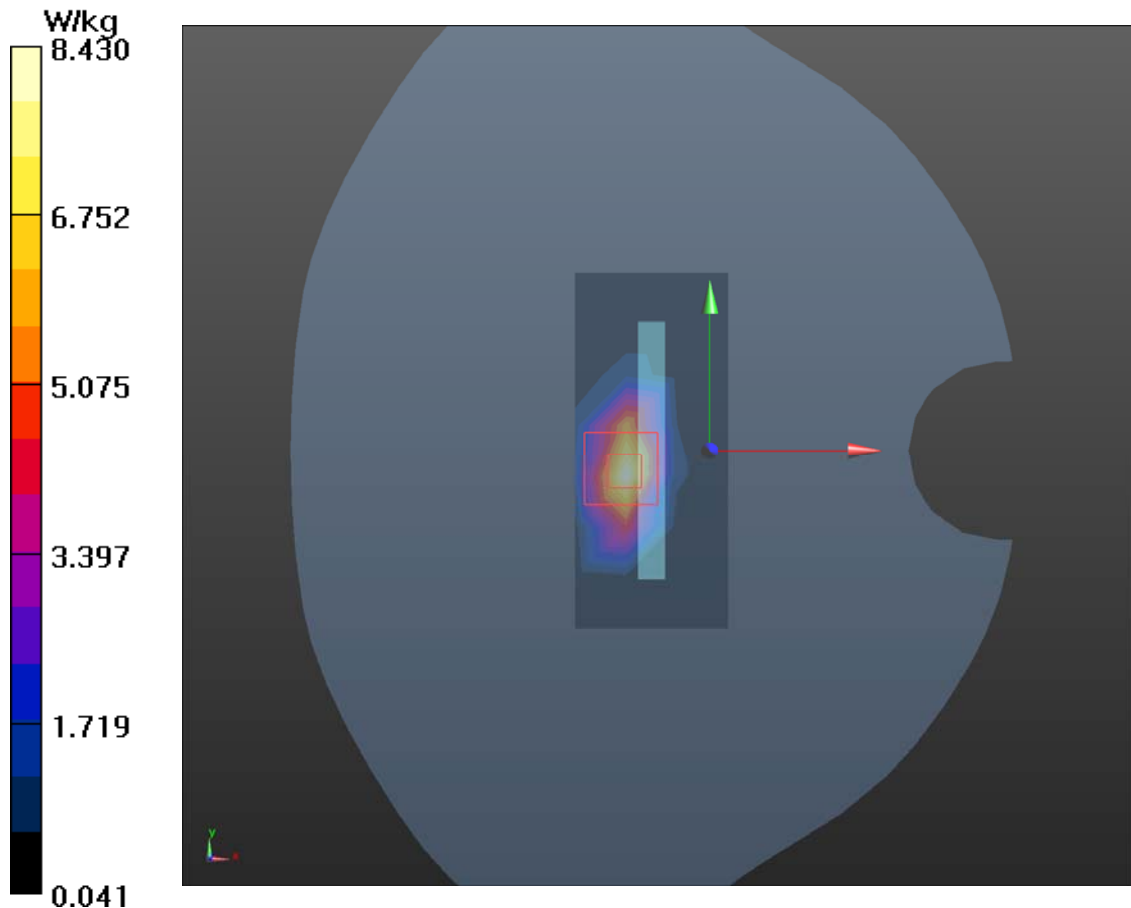

Plot 37 LTE (EN-DC) Band 66 50%RB Right Cheek Middle

Date: 9/28/2020

Communication System: UID 0, LTE (0); Frequency: 1745 MHz; Duty Cycle: 1:1

Medium parameters used: $f = 1745 \text{ MHz}$; $\sigma = 1.323 \text{ S/m}$; $\epsilon_r = 39.378$; $\rho = 1000 \text{ kg/m}^3$

Ambient Temperature: $22.3 \text{ }^\circ\text{C}$ Liquid Temperature: $21.5 \text{ }^\circ\text{C}$

Phantom section: Right Section

DASY5 Configuration:

Sensor-Surface: 1.4mm (Mechanical Surface Detection)

Probe: EX3DV4 - SN3677; ConvF(8.25, 8.25, 8.25); Calibrated: 7/6/2020;

Electronics: DAE4 SN1317; Calibrated: 10/23/2019

Phantom: SAM1; Type: SAM; Serial: TP-1534

Measurement SW: DASY52, Version 52.10 (1); SEMCAD X Version 14.6.11 (7439)

Right Cheek Middle/Area Scan (8x14x1): Measurement grid: $dx=15\text{mm}$, $dy=15\text{mm}$

Maximum value of SAR (measured) = 0.136 W/kg

Right Cheek Middle/Zoom Scan (5x5x7)/Cube 0: Measurement grid: $dx=8\text{mm}$, $dy=8\text{mm}$, $dz=5\text{mm}$

Reference Value = 4.121 V/m ; Power Drift = 0.029 dB

Peak SAR (extrapolated) = 0.198 W/kg

SAR(1 g) = 0.131 W/kg ; SAR(10 g) = 0.083 W/kg

Maximum value of SAR (measured) = 0.141 W/kg

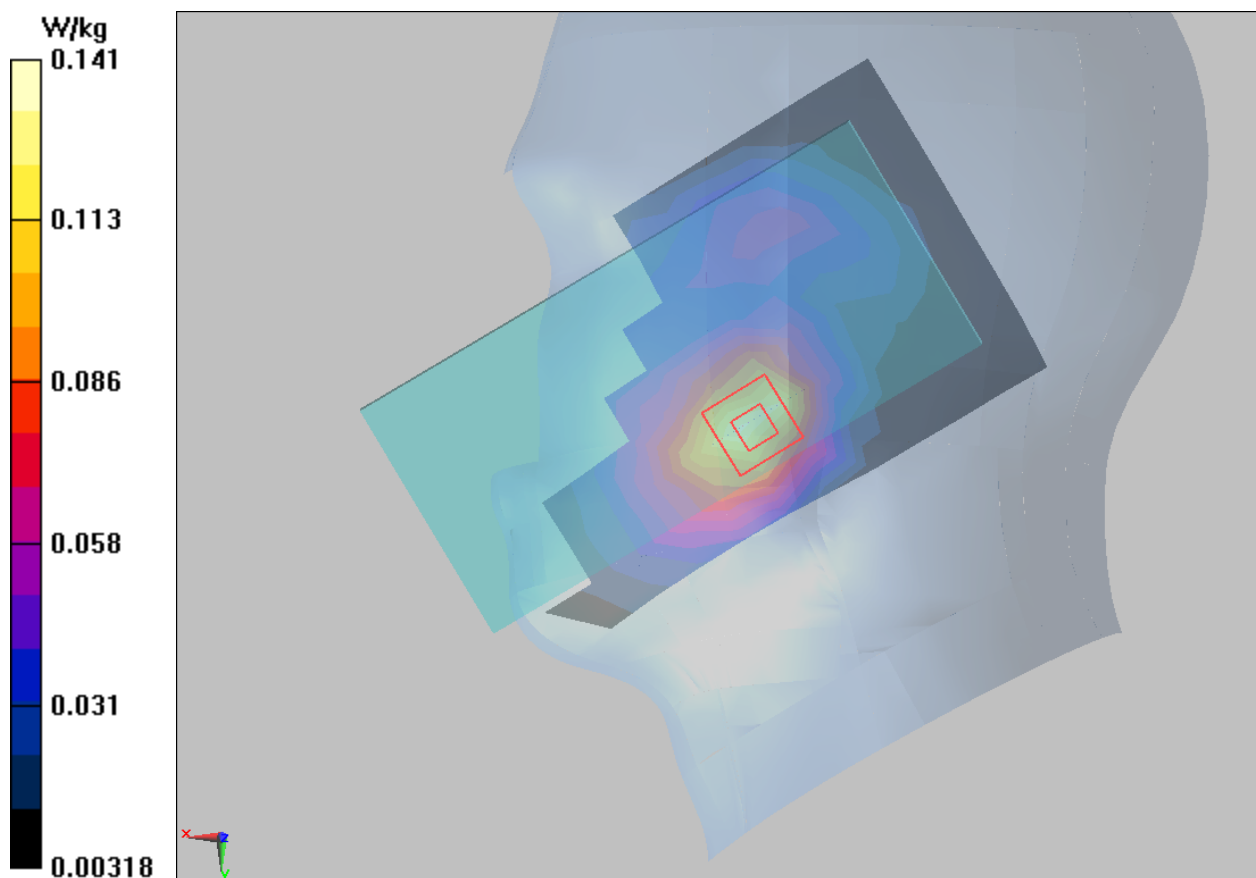

Plot 38 LTE (EN-DC) Band 66 1RB Back Side Low (Distance 15mm)

Date: 9/28/2020

Communication System: UID 0, LTE (0); Frequency: 1770 MHz; Duty Cycle: 1:1

Medium parameters used: $f = 1770$ MHz; $\sigma = 1.341$ S/m; $\epsilon_r = 39.287$; $\rho = 1000$ kg/m³

Ambient Temperature: 22.3 °C Liquid Temperature: 21.5 °C

Phantom section: Flat Section

DASY5 Configuration:

Sensor-Surface: 1.4mm (Mechanical Surface Detection)

Probe: EX3DV4 - SN3677; ConvF(8.25, 8.25, 8.25); Calibrated: 7/6/2020;

Electronics: DAE4 SN1317; Calibrated: 10/23/2019

Phantom: SAM1; Type: SAM; Serial: TP-1534

Measurement SW: DASY52, Version 52.10 (1); SEMCAD X Version 14.6.11 (7439)

Back Side High/Area Scan (8x15x1): Measurement grid: dx=15mm, dy=15mm

Maximum value of SAR (measured) = 0.255 W/kg

Back Side High/Zoom Scan (5x5x7)/Cube 0: Measurement grid: dx=8mm, dy=8mm, dz=5mm

Reference Value = 8.541 V/m; Power Drift = 0.024 dB

Peak SAR (extrapolated) = 0.395 W/kg

SAR(1 g) = 0.263 W/kg; SAR(10 g) = 0.170 W/kg

Maximum value of SAR (measured) = 0.281 W/kg

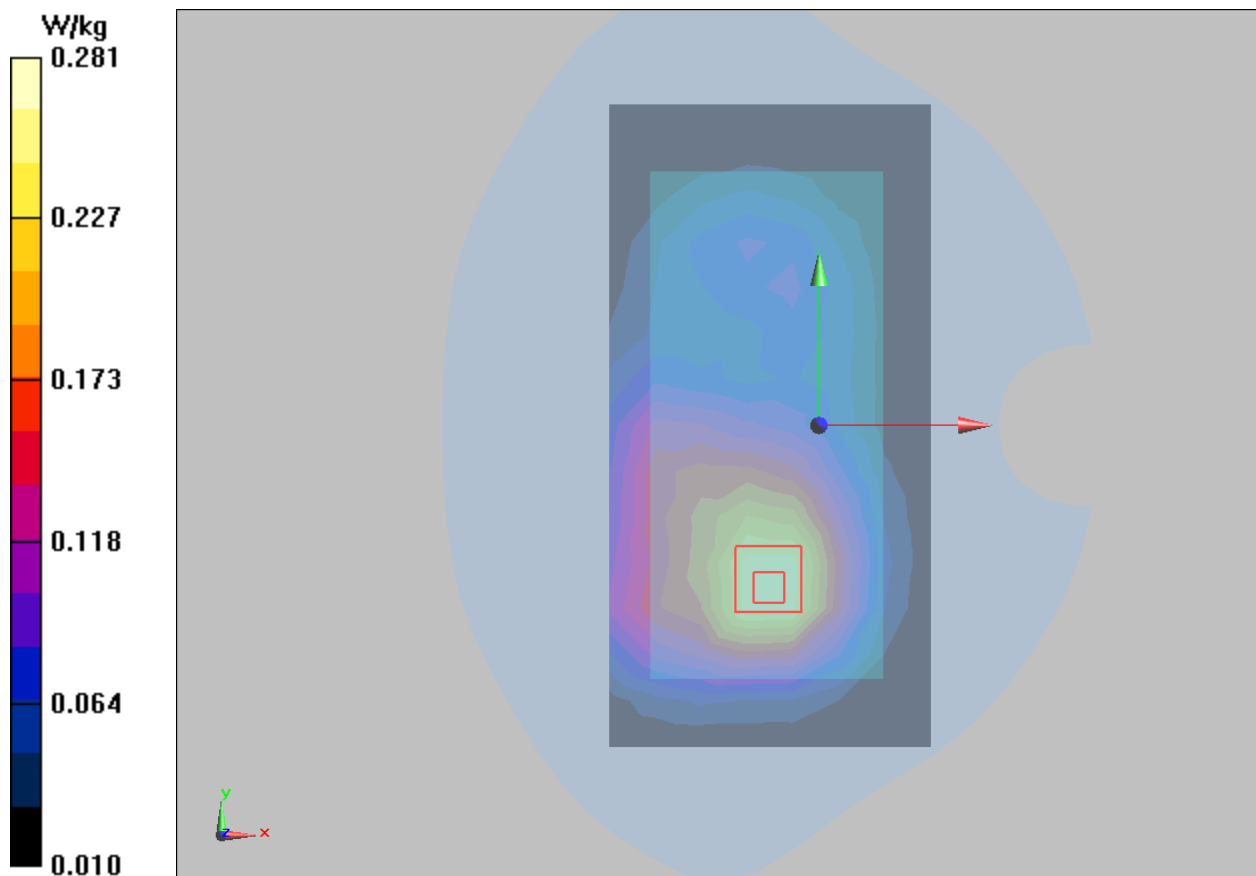

Plot 39 LTE (EN-DC) Band 66 1RB Back Side Middle (Distance 10mm)

Date: 9/28/2020

Communication System: UID 0, LTE (0); Frequency: 1720 MHz; Duty Cycle: 1:1

Medium parameters used: $f = 1720$ MHz; $\sigma = 1.303$ S/m; $\epsilon_r = 39.467$; $\rho = 1000$ kg/m³

Ambient Temperature: 22.3 °C Liquid Temperature: 21.5 °C

Phantom section: Flat Section

DASY5 Configuration:

Sensor-Surface: 1.4mm (Mechanical Surface Detection)

Probe: EX3DV4 - SN3677; ConvF(8.25, 8.25, 8.25); Calibrated: 7/6/2020;

Electronics: DAE4 SN1317; Calibrated: 10/23/2019

Phantom: SAM1; Type: SAM; Serial: TP-1534

Measurement SW: DASY52, Version 52.10 (1); SEMCAD X Version 14.6.11 (7439)

Back Side Low/Area Scan (8x15x1): Measurement grid: dx=15mm, dy=15mm

Maximum value of SAR (measured) = 0.398 W/kg

Back Side Low/Zoom Scan (5x5x7)/Cube 0: Measurement grid: dx=8mm, dy=8mm, dz=5mm

Reference Value = 9.629 V/m; Power Drift = 0.19 dB

Peak SAR (extrapolated) = 0.561 W/kg

SAR(1 g) = 0.381 W/kg; SAR(10 g) = 0.251 W/kg

Maximum value of SAR (measured) = 0.411 W/kg

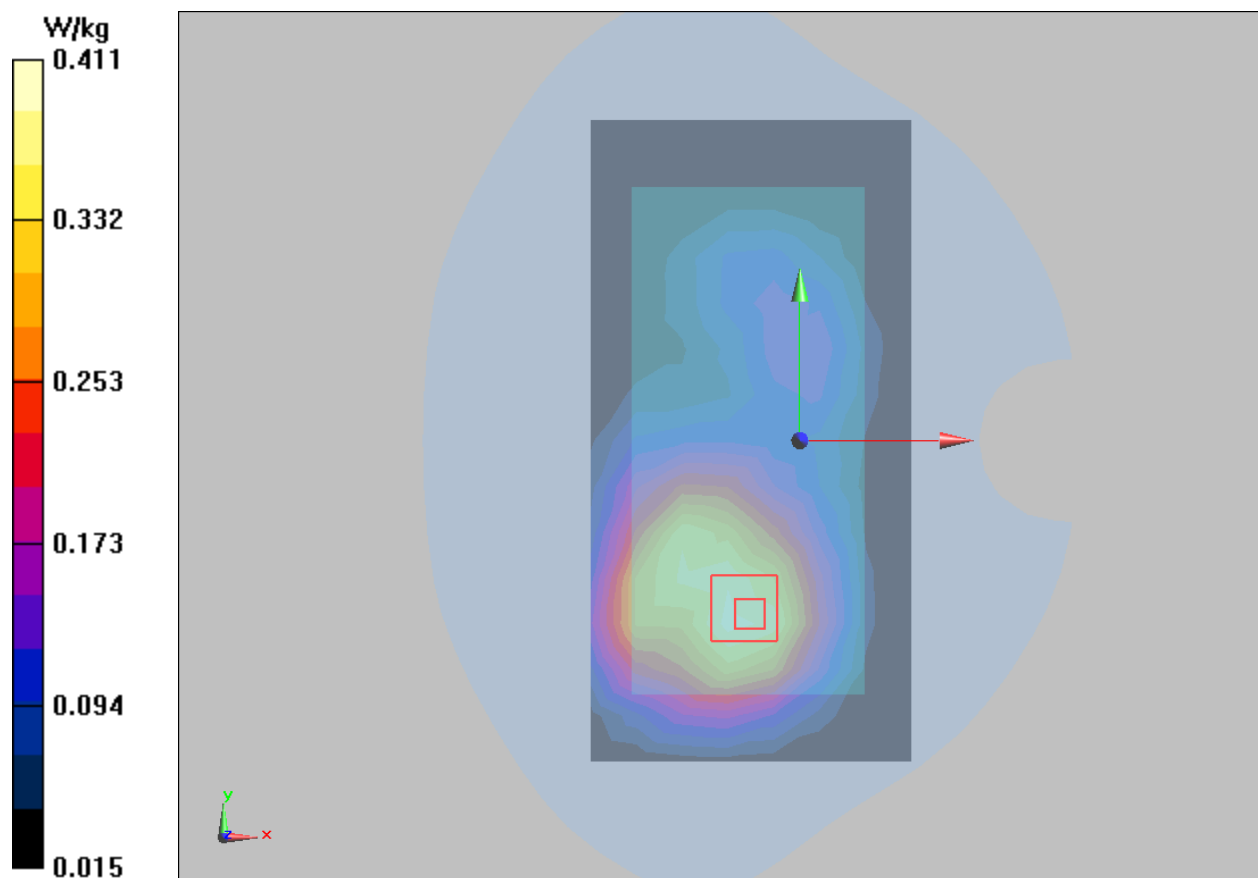

Plot 40 NR n2 50%RB Left Cheek Middle

Date: 9/4/2020

Communication System: UID 0, 5G NR (0); Frequency: 1880 MHz; Duty Cycle: 1:1

Medium parameters used: $f = 1880$ MHz; $\sigma = 1.42$ S/m; $\epsilon_r = 38.948$; $\rho = 1000$ kg/m³

Ambient Temperature: 22.3 °C Liquid Temperature: 21.5 °C

Phantom section: Left Section

DASY5 Configuration:

Sensor-Surface: 1.4mm (Mechanical Surface Detection)

Probe: EX3DV4 - SN3677; ConvF(7.90, 7.90, 7.90); Calibrated: 7/6/2020;

Electronics: DAE4 SN1317; Calibrated: 10/23/2019

Phantom: SAM1; Type: SAM; Serial: TP-1534

Measurement SW: DASY52, Version 52.10 (1); SEMCAD X Version 14.6.11 (7439)

Left Cheek Middle/Area Scan (8x14x1): Measurement grid: dx=15mm, dy=15mm

Maximum value of SAR (measured) = 0.294 W/kg

Left Cheek Middle /Zoom Scan (5x5x7)/Cube 0: Measurement grid: dx=8mm, dy=8mm, dz=5mm

Reference Value = 4.567 V/m; Power Drift = 0.037 dB

Peak SAR (extrapolated) = 0.425 W/kg

SAR(1 g) = 0.273 W/kg; SAR(10 g) = 0.170 W/kg

Maximum value of SAR (measured) = 0.295 W/kg

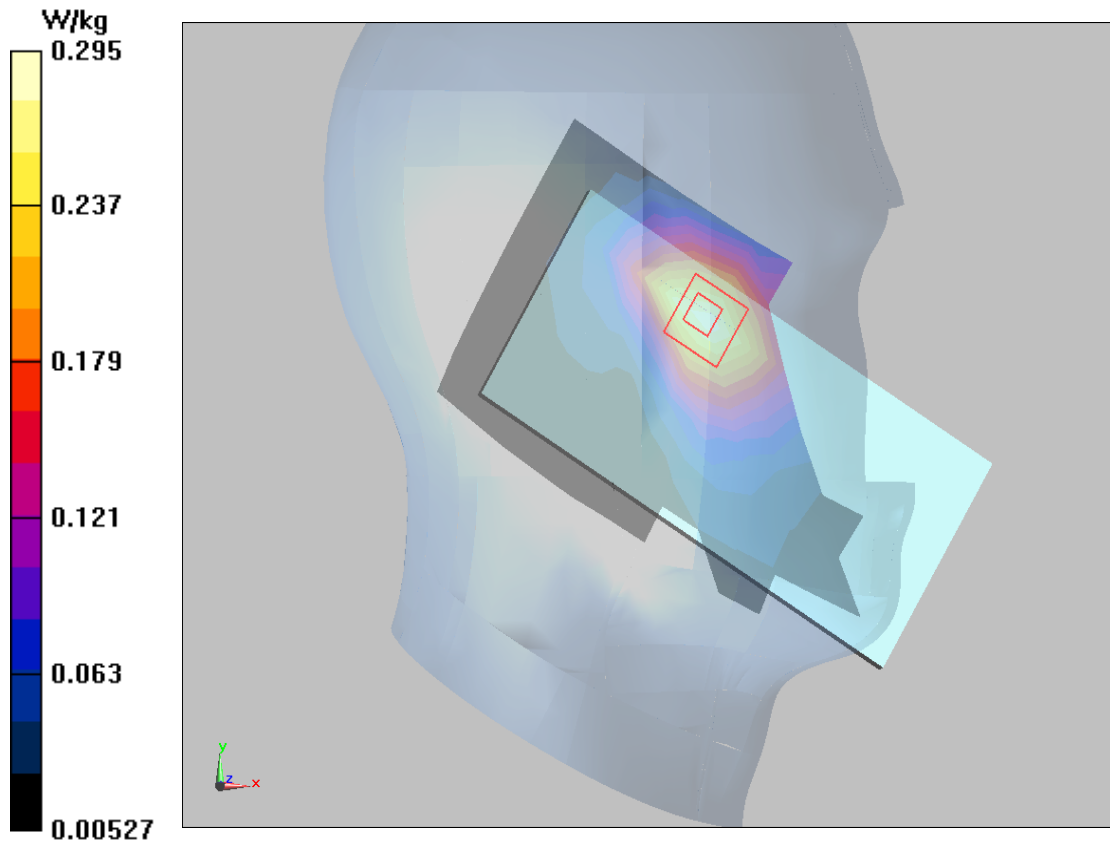

Plot 41 NR n2 1RB Back Side Middle (Distance 15mm)

Date: 9/4/2020

Communication System: UID 0, 5G NR (0); Frequency: 1880 MHz; Duty Cycle: 1:1

Medium parameters used: $f = 1880$ MHz; $\sigma = 1.393$ S/m; $\epsilon_r = 38.344$; $\rho = 1000$ kg/m³

Ambient Temperature: 22.3 °C Liquid Temperature: 21.5 °C

Phantom section: Flat Section

DASY5 Configuration:

Sensor-Surface: 1.4mm (Mechanical Surface Detection)

Probe: EX3DV4 - SN3677; ConvF(7.90, 7.90, 7.90); Calibrated: 7/6/2020;

Electronics: DAE4 SN1317; Calibrated: 10/23/2019

Phantom: SAM1; Type: SAM; Serial: TP-1534

Measurement SW: DASY52, Version 52.10 (1); SEMCAD X Version 14.6.11 (7439)

Back Side Middle/Area Scan (8x15x1): Measurement grid: dx=15mm, dy=15mm

Maximum value of SAR (measured) = 0.344 W/kg

Back Side Middle/Zoom Scan (5x5x7)/Cube 0: Measurement grid: dx=8mm, dy=8mm, dz=5mm

Reference Value = 10.50 V/m; Power Drift = -0.17 dB

Peak SAR (extrapolated) = 0.588 W/kg

SAR(1 g) = 0.328 W/kg; SAR(10 g) = 0.174 W/kg

Maximum value of SAR (measured) = 0.332 W/kg

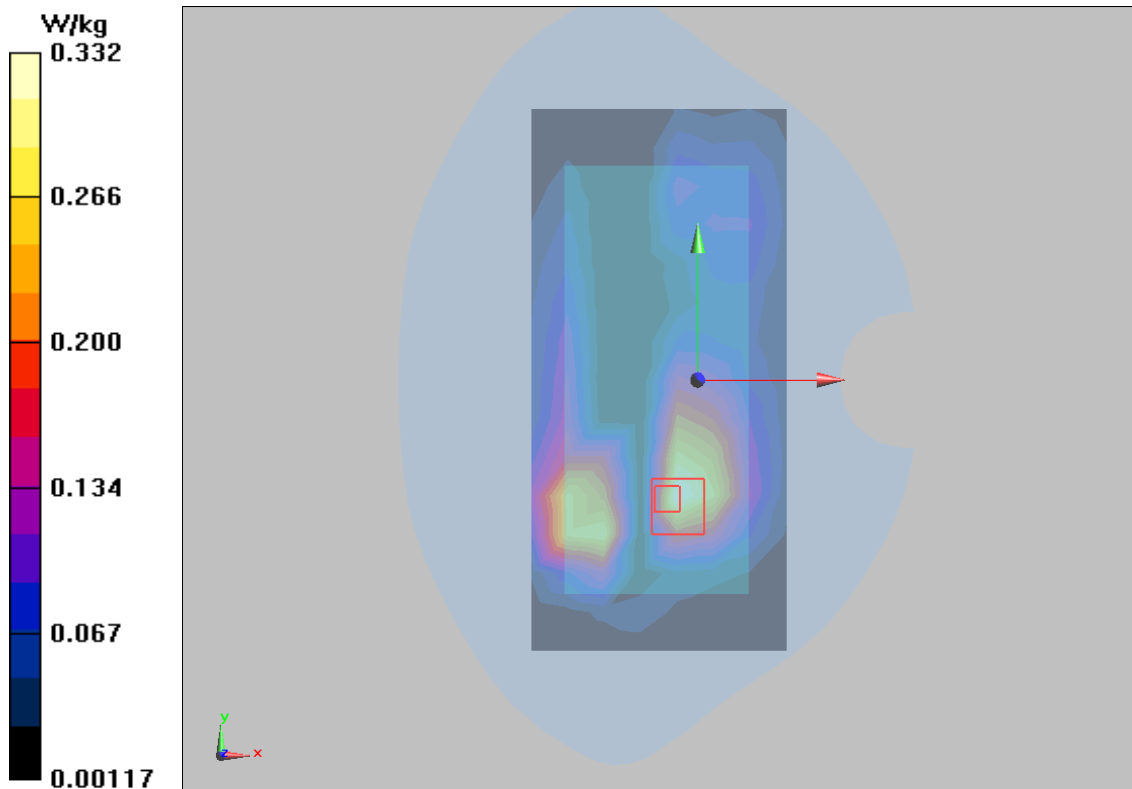

Plot 42 NR n2 1RB Right Edge Middle(Distance 10mm)

Date: 9/4/2020

Communication System: UID 0, 5G NR (0); Frequency: 1880 MHz;Duty Cycle: 1:1

Medium parameters used: $f = 1880$ MHz; $\sigma = 1.42$ S/m; $\epsilon_r = 38.948$; $\rho = 1000$ kg/m³

Ambient Temperature:22.3 °C Liquid Temperature: 21.5°C

Phantom section: Flat Section

DASY5 Configuration:

Sensor-Surface: 1.4mm (Mechanical Surface Detection)

Probe: EX3DV4 - SN3677; ConvF(7.90, 7.90, 7.90); Calibrated: 7/6/2020;

Electronics: DAE4 SN1317; Calibrated: 10/23/2019

Phantom: SAM1; Type: SAM; Serial: TP-1534

Measurement SW: DASY52, Version 52.10 (1); SEMCAD X Version 14.6.11 (7439)

Right Edge Middle /Area Scan (4x15x1): Measurement grid: dx=15mm, dy=15mm

Maximum value of SAR (measured) = 0.577 W/kg

Right Edge Middle /Zoom Scan (5x5x7)/Cube 0: Measurement grid: dx=8mm, dy=8mm, dz=5mm

Reference Value = 10.26 V/m; Power Drift = 0.02 dB

Peak SAR (extrapolated) = 0.971 W/kg

SAR(1 g) = 0.566 W/kg; SAR(10 g) = 0.325 W/kg

Maximum value of SAR (measured) = 0.617 W/kg

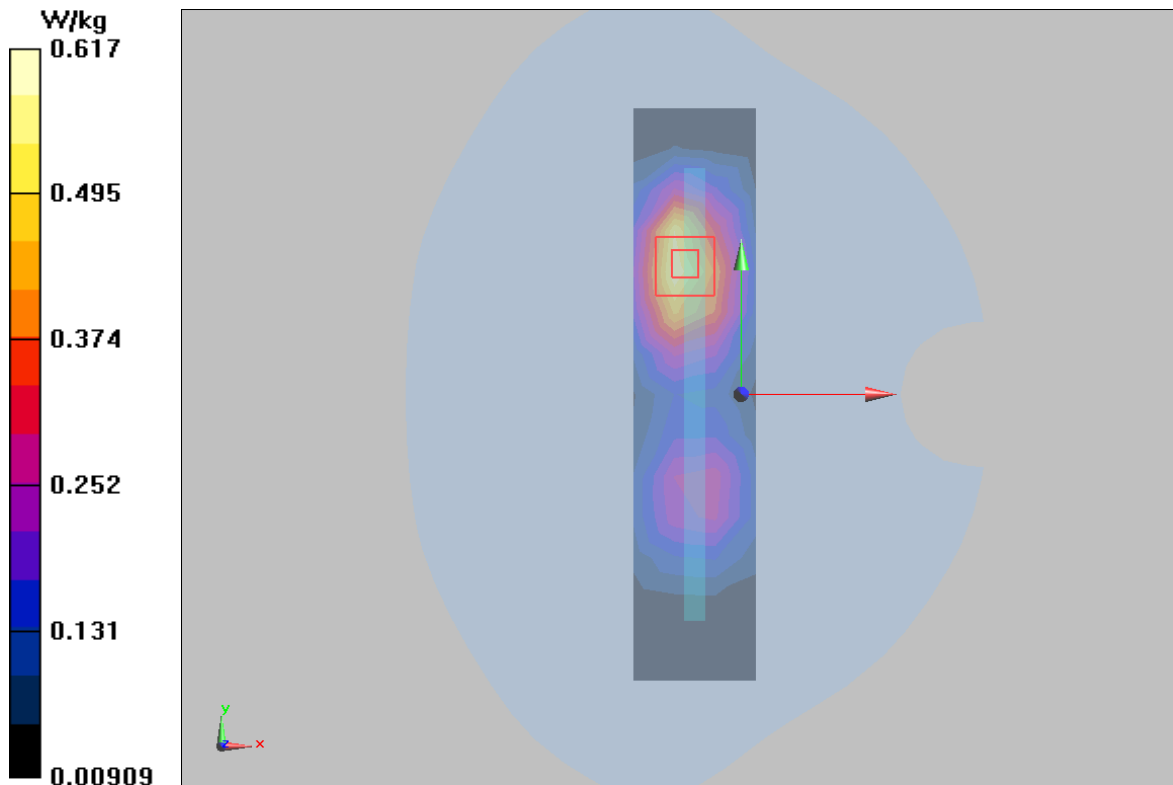

Plot 43 NR n5 100%RB Right Cheek Low

Date: 10/17/2020

Communication System: UID 0, 5G NR (0); Frequency: 834 MHz; Duty Cycle: 1:1

Medium parameters used: $f = 834$ MHz; $\sigma = 0.921$ S/m; $\epsilon_r = 42.195$; $\rho = 1000$ kg/m³

Ambient Temperature: 22.3 °C Liquid Temperature: 21.5 °C

Phantom section: Right Section

DASY5 Configuration:

Sensor-Surface: 1.4mm (Mechanical Surface Detection)

Probe: EX3DV4 - SN3677; ConvF(9.38, 9.38, 9.38); Calibrated: 7/6/2020;

Electronics: DAE4 SN1317; Calibrated: 10/23/2019

Phantom: SAM1; Type: SAM; Serial: TP-1534

Measurement SW: DASY52, Version 52.10 (1); SEMCAD X Version 14.6.11 (7439)

Right Cheek Low/Area Scan (8x14x1): Measurement grid: dx=15mm, dy=15mm

Maximum value of SAR (measured) = 0.949 W/kg

Right Cheek Low/Zoom Scan (5x5x7)/Cube 0: Measurement grid: dx=8mm, dy=8mm, dz=5mm

Reference Value = 26.55 V/m; Power Drift = 0.00 dB

Peak SAR (extrapolated) = 2.120 W/kg

SAR(1 g) = 1.060 W/kg; SAR(10 g) = 0.582 W/kg

Maximum value of SAR (measured) = 1.190 W/kg

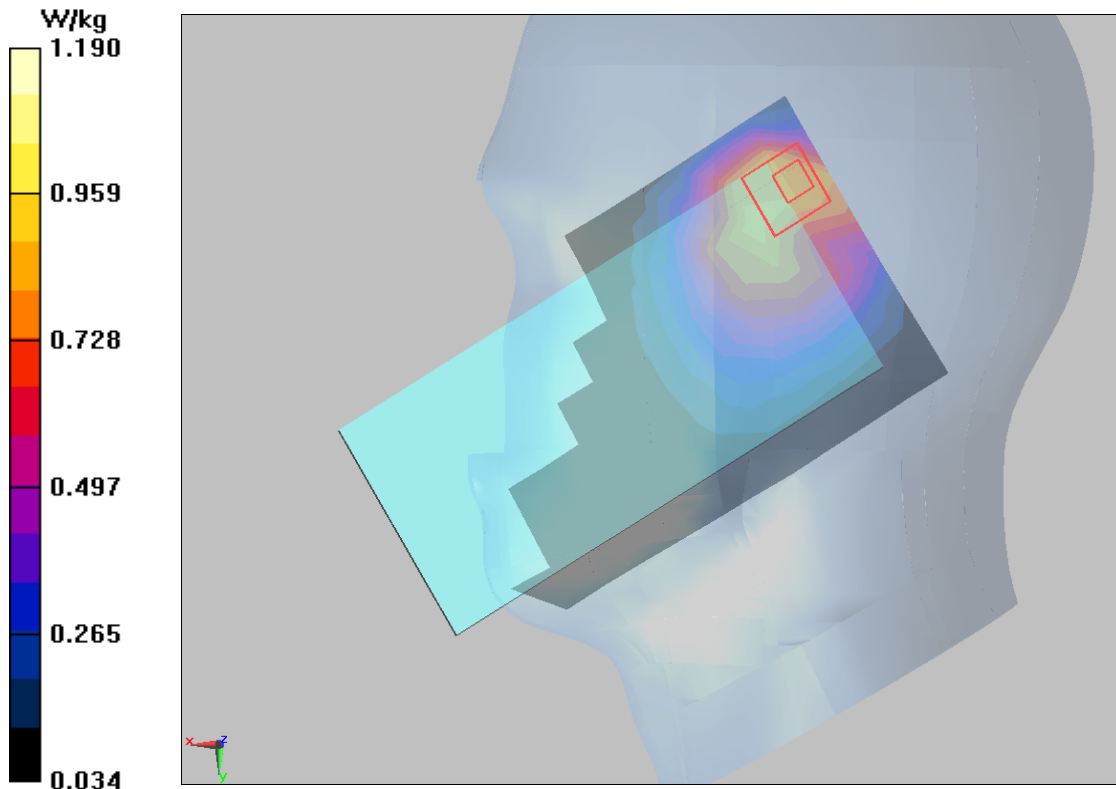

Plot 44 NR n5 50%RB Back Side Low (Distance 15mm)

Date: 10/17/2020

Communication System: UID 0, 5G NR (0); Frequency: 834 MHz;Duty Cycle: 1:1

Medium parameters used: $f = 834 \text{ MHz}$; $\sigma = 0.921 \text{ S/m}$; $\epsilon_r = 42.195$; $\rho = 1000 \text{ kg/m}^3$

Ambient Temperature:22.3 °C Liquid Temperature: 21.5°C

Phantom section: Flat Section

DASY5 Configuration:

Sensor-Surface: 1.4mm (Mechanical Surface Detection)

Probe: EX3DV4 - SN3677; ConvF(9.38, 9.38, 9.38); Calibrated:7/6/2020;

Electronics: DAE4 SN1317; Calibrated: 10/23/2019

Phantom: SAM1; Type: SAM; Serial: TP-1534

Measurement SW: DASY52, Version 52.10 (1); SEMCAD X Version 14.6.11 (7439)

Back Side Low/Area Scan (8x15x1): Measurement grid: dx=15mm, dy=15mm

Maximum value of SAR (measured) = 0.466 W/kg

Back Side Low/Zoom Scan (5x5x7)/Cube 0: Measurement grid: dx=8mm, dy=8mm, dz=5mm

Reference Value = 14.64 V/m; Power Drift = -0.03 dB

Peak SAR (extrapolated) = 0.699 W/kg

SAR(1 g) = 0.452 W/kg; SAR(10 g) = 0.290 W/kg

Maximum value of SAR (measured) = 0.488 W/kg

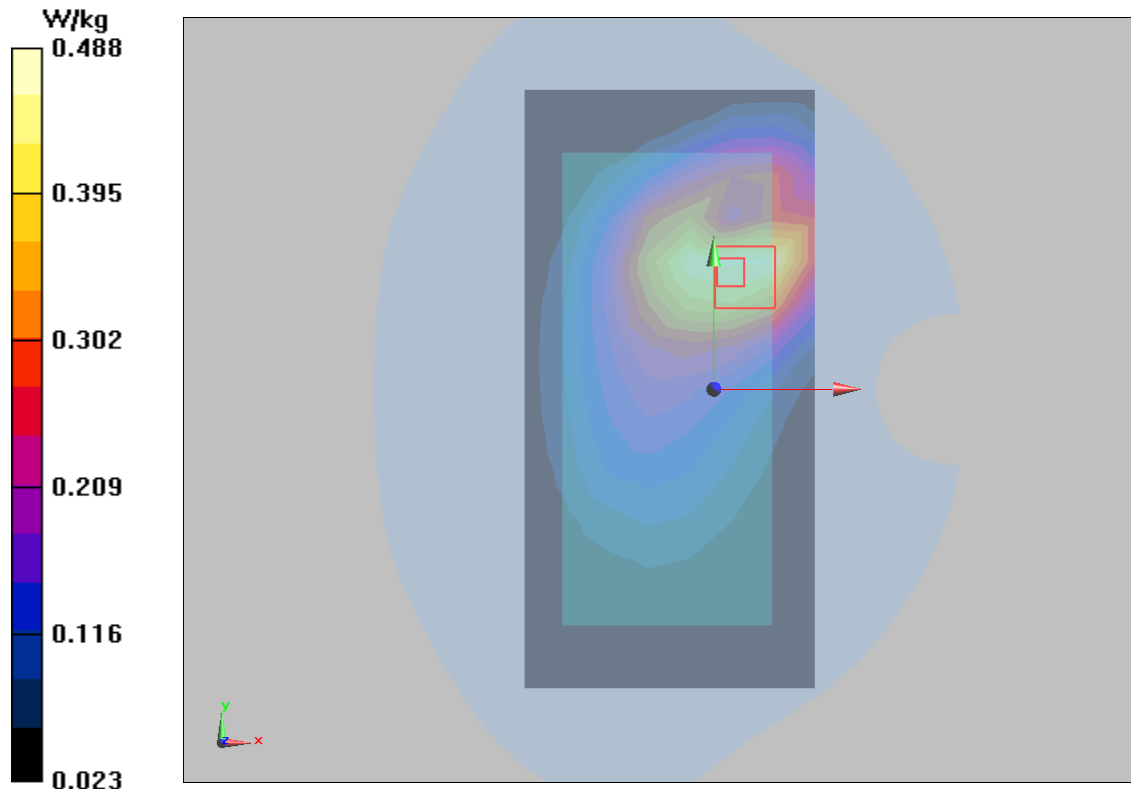

Plot 45 NR n5 1RB Back Side Low (Distance 10mm)

Date: 10/17/2020

Communication System: UID 0, 5G NR (0); Frequency: 834 MHz; Duty Cycle: 1:1

Medium parameters used: $f = 834 \text{ MHz}$; $\sigma = 0.921 \text{ S/m}$; $\epsilon_r = 42.195$; $\rho = 1000 \text{ kg/m}^3$

Ambient Temperature: $22.3 \text{ }^\circ\text{C}$ Liquid Temperature: $21.5 \text{ }^\circ\text{C}$

Phantom section: Flat Section

DASY5 Configuration:

Sensor-Surface: 1.4mm (Mechanical Surface Detection)

Probe: EX3DV4 - SN3677; ConvF(9.38, 9.38, 9.38); Calibrated: 7/6/2020;

Electronics: DAE4 SN1317; Calibrated: 10/23/2019

Phantom: SAM1; Type: SAM; Serial: TP-1534

Measurement SW: DASY52, Version 52.10 (1); SEMCAD X Version 14.6.11 (7439)

Back Side Low/Area Scan (8x15x1): Measurement grid: $dx=15\text{mm}$, $dy=15\text{mm}$

Maximum value of SAR (measured) = 0.635 W/kg

Back Side Low/Zoom Scan (5x5x7)/Cube 0: Measurement grid: $dx=8\text{mm}$, $dy=8\text{mm}$, $dz=5\text{mm}$

Reference Value = 12.43 V/m ; Power Drift = -0.024 dB

Peak SAR (extrapolated) = 0.983 W/kg

SAR(1 g) = 0.584 W/kg ; SAR(10 g) = 0.361 W/kg

Maximum value of SAR (measured) = 0.626 W/kg

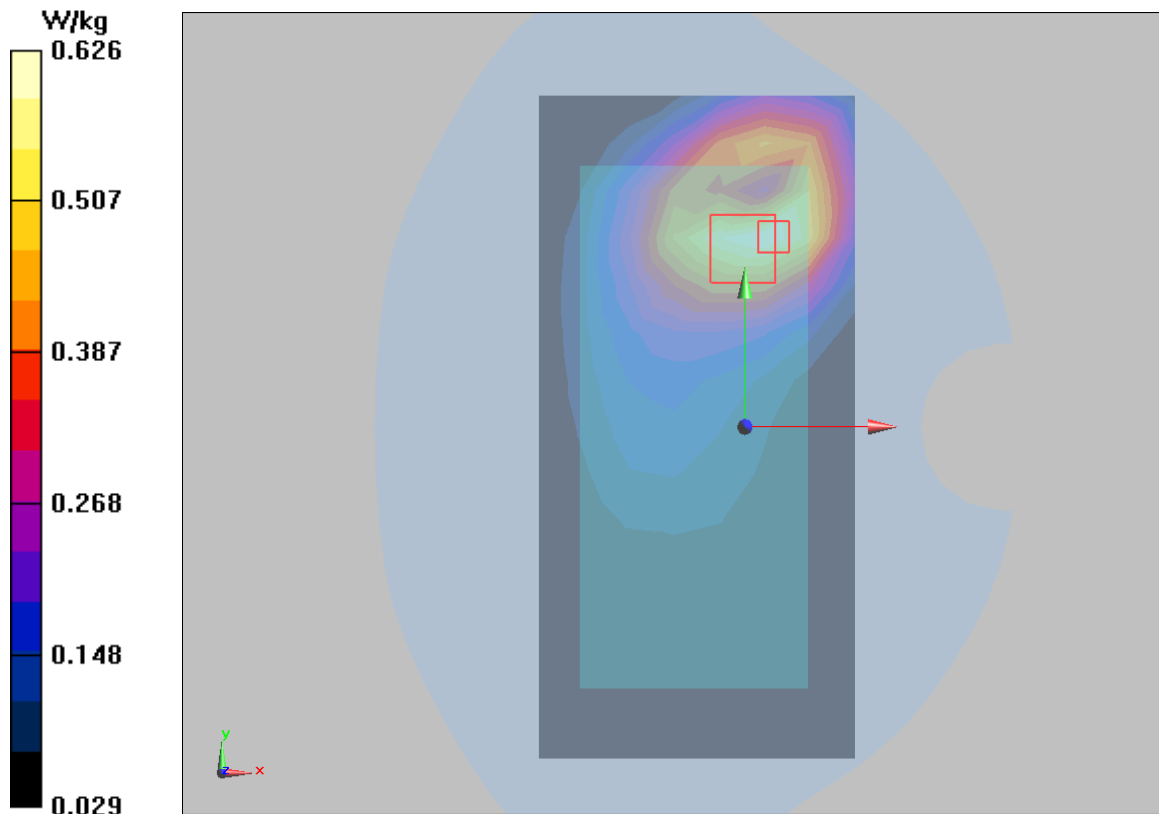

Plot 46 NR n66 1RB Right Cheek High

Date: 8/28/2020

Communication System: UID 0, 5G NR (0); Frequency: 1770 MHz; Duty Cycle: 1:1

Medium parameters used: $f = 1770$ MHz; $\sigma = 1.341$ S/m; $\epsilon_r = 39.287$; $\rho = 1000$ kg/m³

Ambient Temperature: 22.3 °C Liquid Temperature: 21.5 °C

Phantom section: Right Section

DASY5 Configuration:

Sensor-Surface: 1.4mm (Mechanical Surface Detection)

Probe: EX3DV4 - SN3677; ConvF(8.25, 8.25, 8.25); Calibrated: 7/6/2020;

Electronics: DAE4 SN1317; Calibrated: 10/23/2019

Phantom: SAM1; Type: SAM; Serial: TP-1534

Measurement SW: DASY52, Version 52.10 (1); SEMCAD X Version 14.6.11 (7439)

Right Cheek High/Area Scan (8x14x1): Measurement grid: dx=15mm, dy=15mm

Maximum value of SAR (measured) = 0.254 W/kg

Right Cheek High/Zoom Scan (5x5x7)/Cube 0: Measurement grid: dx=8mm, dy=8mm, dz=5mm

Reference Value = 4.845 V/m; Power Drift = 0.036 dB

Peak SAR (extrapolated) = 0.364 W/kg

SAR(1 g) = 0.244 W/kg; SAR(10 g) = 0.155 W/kg

Maximum value of SAR (measured) = 0.261 W/kg

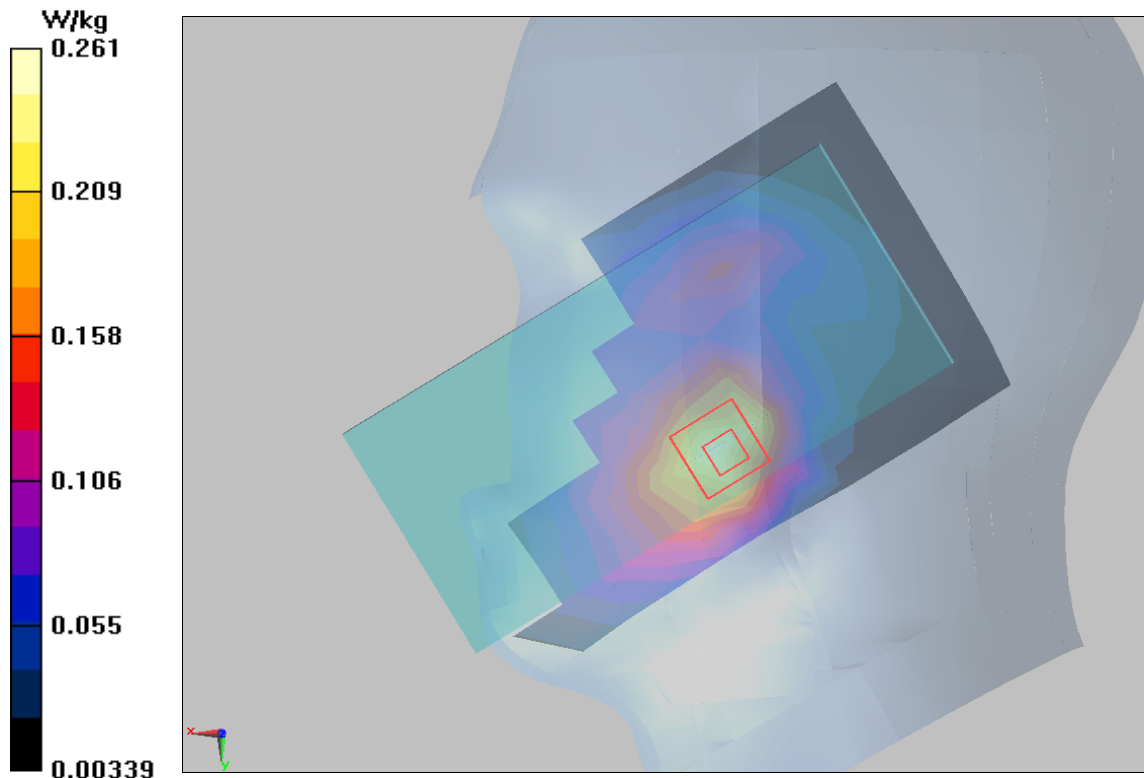

Plot 47 NR n66 1RB Front Side High (Distance 15mm)

Date: 8/28/2020

Communication System: UID 0, 5G NR (0); Frequency: 1770 MHz; Duty Cycle: 1:1

Medium parameters used: $f = 1770$ MHz; $\sigma = 1.341$ S/m; $\epsilon_r = 39.287$; $\rho = 1000$ kg/m³

Ambient Temperature: 22.3 °C Liquid Temperature: 21.5 °C

Phantom section: Flat Section

DASY5 Configuration:

Sensor-Surface: 1.4mm (Mechanical Surface Detection)

Probe: EX3DV4 - SN3677; ConvF(8.25, 8.25, 8.25); Calibrated: 7/6/2020;

Electronics: DAE4 SN1317; Calibrated: 10/23/2019

Phantom: SAM1; Type: SAM; Serial: TP-1534

Measurement SW: DASY52, Version 52.10 (1); SEMCAD X Version 14.6.11 (7439)

Front Side High/Area Scan (8x15x1): Measurement grid: dx=15mm, dy=15mm

Maximum value of SAR (measured) = 0.386 W/kg

Front Side High/Zoom Scan (5x5x7)/Cube 0: Measurement grid: dx=8mm, dy=8mm, dz=5mm

Reference Value = 7.148 V/m; Power Drift = -0.01 dB

Peak SAR (extrapolated) = 0.572 W/kg

SAR(1 g) = 0.380 W/kg; SAR(10 g) = 0.247 W/kg

Maximum value of SAR (measured) = 0.407 W/kg

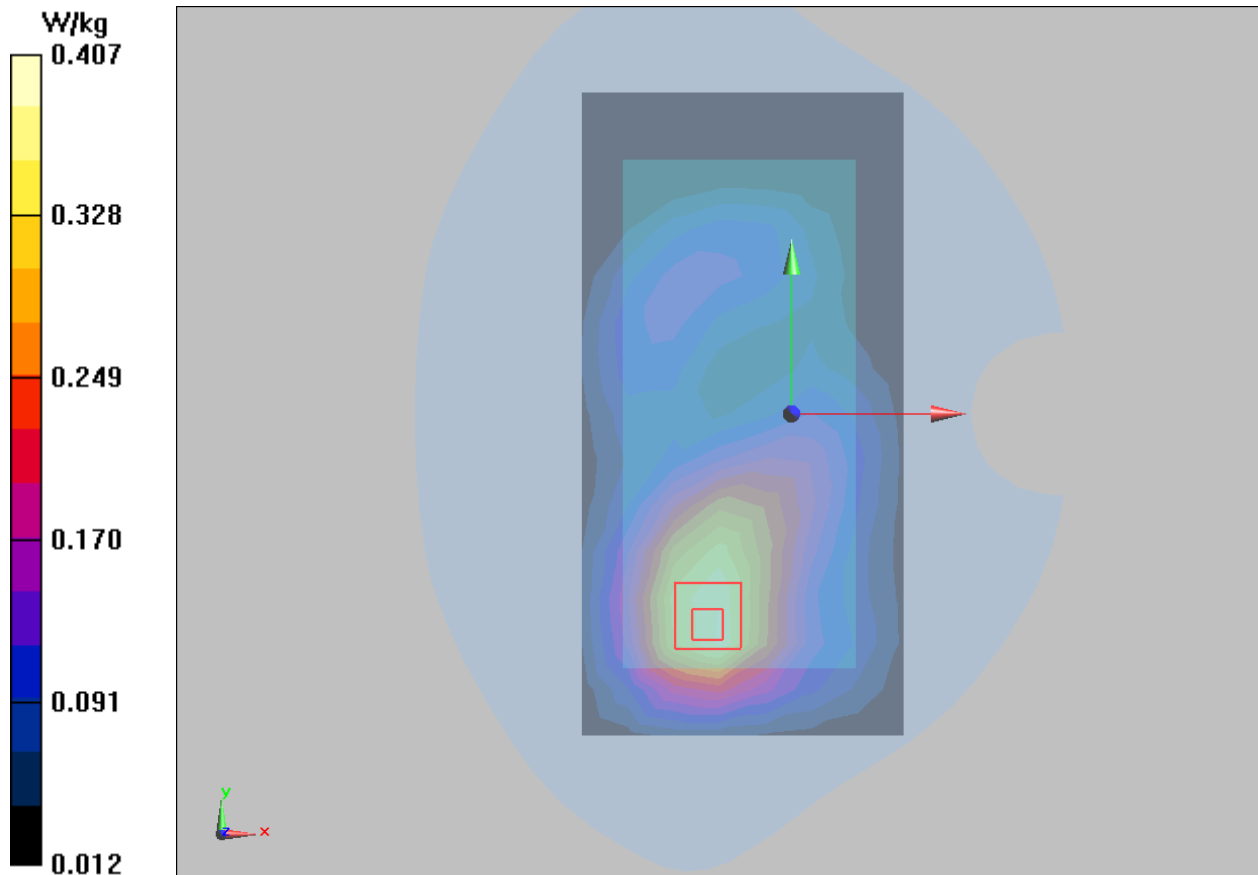

Plot 48 NR n66 50%RB Right Edge High (Distance 10mm)

Date: 8/28/2020

Communication System: UID 0, 5G NR (0); Frequency: 1770 MHz; Duty Cycle: 1:1

Medium parameters used: $f = 1770$ MHz; $\sigma = 1.341$ S/m; $\epsilon_r = 39.287$; $\rho = 1000$ kg/m³

Ambient Temperature: 22.3 °C Liquid Temperature: 21.5 °C

Phantom section: Flat Section

DASY5 Configuration:

Sensor-Surface: 1.4mm (Mechanical Surface Detection)

Probe: EX3DV4 - SN3677; ConvF(8.25, 8.25, 8.25); Calibrated: 7/6/2020;

Electronics: DAE4 SN1317; Calibrated: 10/23/2019

Phantom: SAM1; Type: SAM; Serial: TP-1534

Measurement SW: DASY52, Version 52.10 (1); SEMCAD X Version 14.6.11 (7439)

Right Edge High/Area Scan (4x15x1): Measurement grid: dx=15mm, dy=15mm

Maximum value of SAR (measured) = 0.681 W/kg

Right Edge High/Zoom Scan (5x5x7)/Cube 0: Measurement grid: dx=8mm, dy=8mm, dz=5mm

Reference Value = 15.17 V/m; Power Drift = 0.13 dB

Peak SAR (extrapolated) = 1.17 W/kg

SAR(1 g) = 0.699 W/kg; SAR(10 g) = 0.401 W/kg

Maximum value of SAR (measured) = 0.765 W/kg

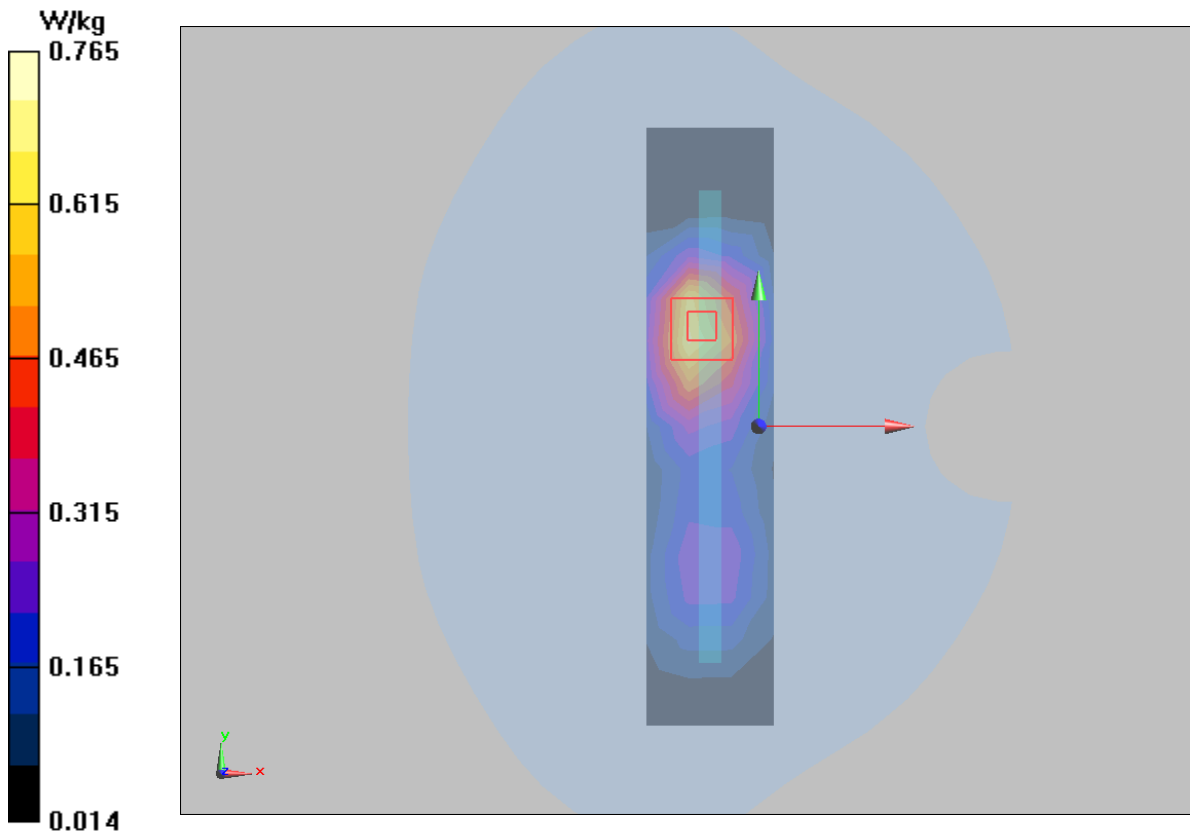

Plot 49 802.11b Left Cheek Middle

Date: 9/10/2020

Communication System: UID 0, 802.11b (0); Frequency: 2437 MHz; Duty Cycle: 1:1.01

Medium parameters used: $f = 2437$ MHz; $\sigma = 1.797$ S/m; $\epsilon_r = 38.629$; $\rho = 1000$ kg/m³

Ambient Temperature: 22.3 °C Liquid Temperature: 21.5 °C

Phantom section: Left Section

DASY5 Configuration:

Sensor-Surface: 1.4mm (Mechanical Surface Detection)

Probe: EX3DV4 - SN3677; ConvF(7.54, 7.54, 7.54); Calibrated: 7/6/2020;

Electronics: DAE4 SN1317; Calibrated: 10/23/2019

Phantom: SAM1; Type: SAM; Serial: TP-1534

Measurement SW: DASY52, Version 52.10 (1); SEMCAD X Version 14.6.11 (7439)

Left Cheek Middle/Area Scan (10x19x1): Measurement grid: dx=12mm, dy=12mm

Maximum value of SAR (measured) = 0.752 W/kg

Left Cheek Middle/Zoom Scan (7x7x7)/Cube 0: Measurement grid: dx=5mm, dy=5mm, dz=5mm

Reference Value = 7.118 V/m; Power Drift = 0.030 dB

Peak SAR (extrapolated) = 1.58 W/kg

SAR(1 g) = 0.685 W/kg; SAR(10 g) = 0.329 W/kg

Maximum value of SAR (measured) = 0.727 W/kg

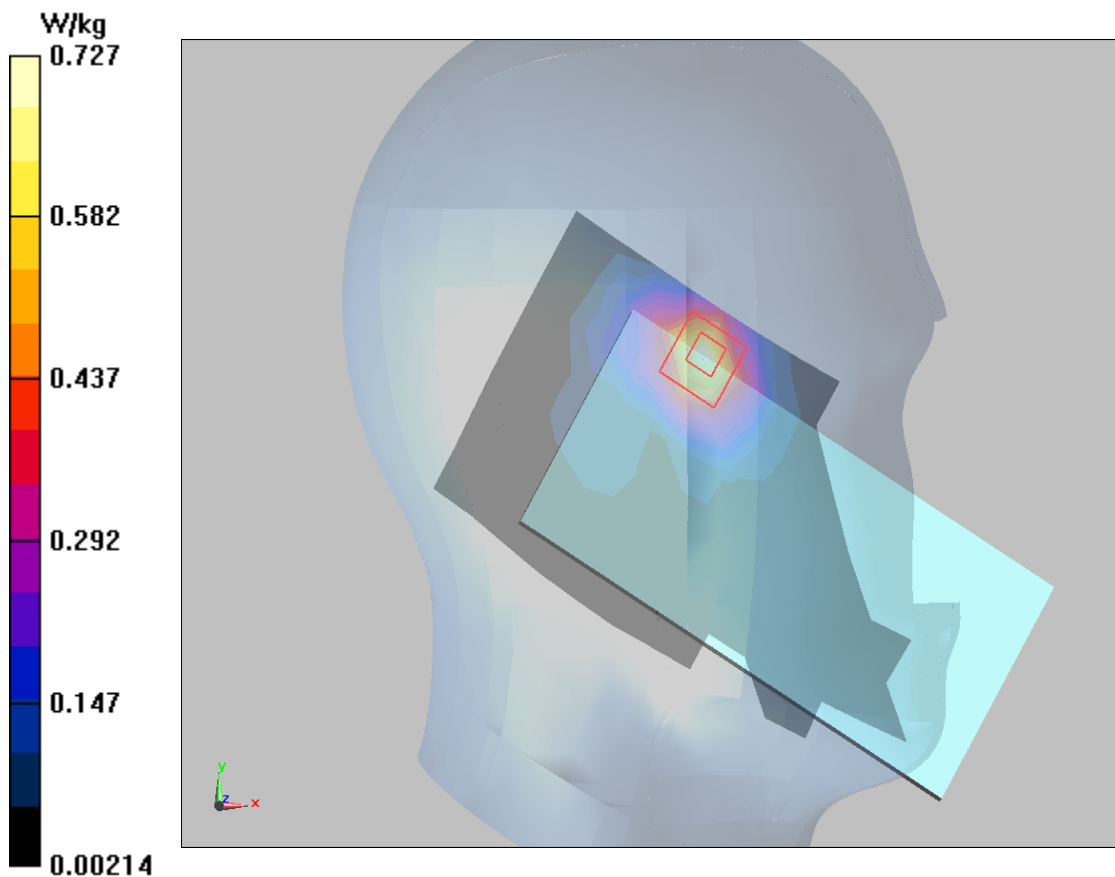

Plot 50 802.11b Back Side Middle (Distance 15mm)

Date: 9/10/2020

Communication System: UID 0, 802.11b (0); Frequency: 2437 MHz; Duty Cycle: 1:1.01

Medium parameters used: $f = 2437 \text{ MHz}$; $\sigma = 1.797 \text{ S/m}$; $\epsilon_r = 38.629$; $\rho = 1000 \text{ kg/m}^3$

Ambient Temperature: $22.3 \text{ }^\circ\text{C}$ Liquid Temperature: $21.5 \text{ }^\circ\text{C}$

Phantom section: Flat Section

DASY5 Configuration:

Sensor-Surface: 1.4mm (Mechanical Surface Detection)

Probe: EX3DV4 - SN3677; ConvF(7.54, 7.54, 7.54); Calibrated: 7/6/2020;

Electronics: DAE4 SN1317; Calibrated: 10/23/2019

Phantom: SAM1; Type: SAM; Serial: TP-1534

Measurement SW: DASY52, Version 52.10 (1); SEMCAD X Version 14.6.11 (7439)

Back Side Middle/Area Scan (10x19x1): Measurement grid: $dx=12\text{mm}$, $dy=12\text{mm}$

Maximum value of SAR (measured) = 0.165 W/kg

Back Side Middle /Zoom Scan (7x7x7)/Cube 0: Measurement grid: $dx=5\text{mm}$, $dy=5\text{mm}$, $dz=5\text{mm}$

Reference Value = 4.779 V/m ; Power Drift = -0.01 dB

Peak SAR (extrapolated) = 0.335 W/kg

SAR(1 g) = 0.163 W/kg ; SAR(10 g) = 0.085 W/kg

Maximum value of SAR (measured) = 0.174 W/kg

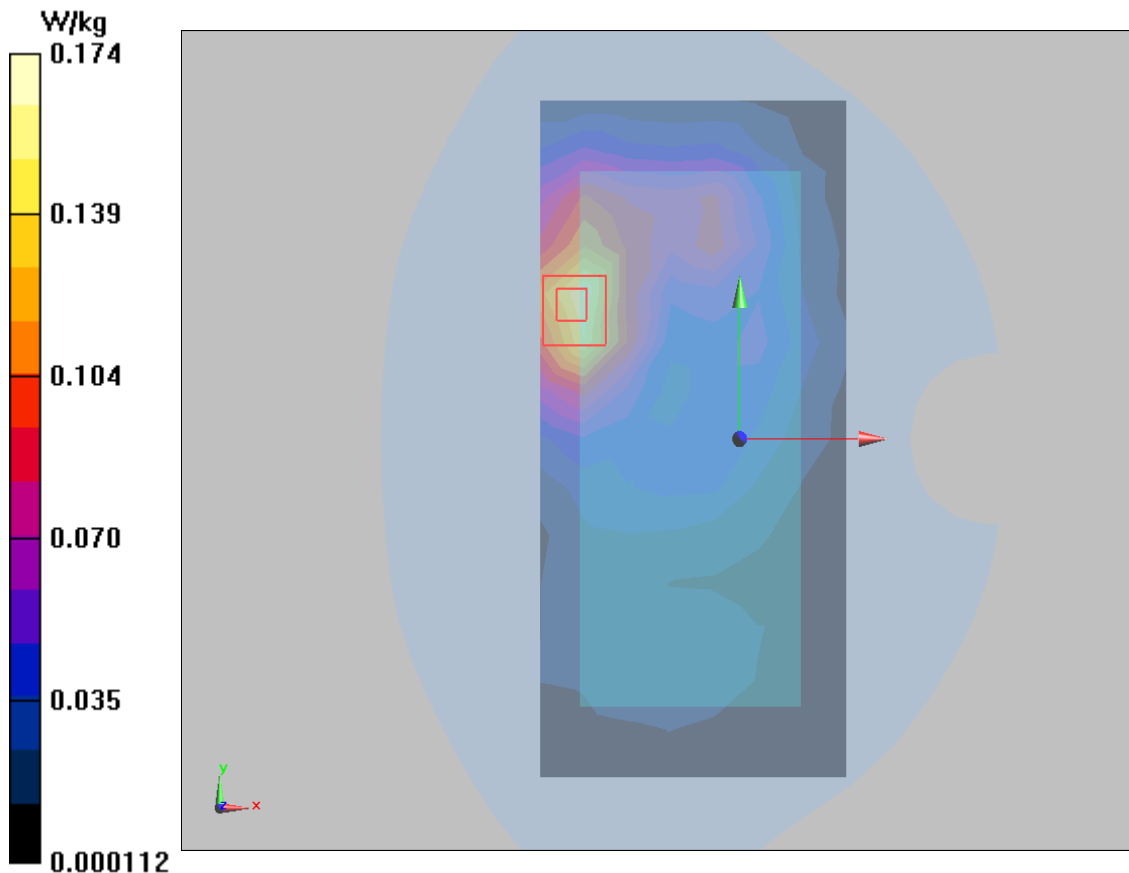

Plot 51 802.11b Back Side Middle (Distance 10mm)

Date: 9/10/2020

Communication System: UID 0, 802.11b (0); Frequency: 2437 MHz; Duty Cycle: 1:1.01

Medium parameters used: $f = 2437$ MHz; $\sigma = 1.797$ S/m; $\epsilon_r = 38.629$; $\rho = 1000$ kg/m³

Ambient Temperature: 22.3 °C Liquid Temperature: 21.5 °C

Phantom section: Flat Section

DASY5 Configuration:

Sensor-Surface: 1.4mm (Mechanical Surface Detection)

Probe: EX3DV4 - SN3677; ConvF(7.54, 7.54, 7.54); Calibrated: 7/6/2020;

Electronics: DAE4 SN1317; Calibrated: 10/23/2019

Phantom: SAM1; Type: SAM; Serial: TP-1534

Measurement SW: DASY52, Version 52.10 (1); SEMCAD X Version 14.6.11 (7439)

Back Side Middle/Area Scan (10x19x1): Measurement grid: dx=12mm, dy=12mm

Maximum value of SAR (measured) = 0.281 W/kg

Back Side Middle/Zoom Scan (7x7x7)/Cube 0: Measurement grid: dx=5mm, dy=5mm, dz=5mm

Reference Value = 4.871 V/m; Power Drift = 0.088 dB

Peak SAR (extrapolated) = 0.667 W/kg

SAR(1 g) = 0.307 W/kg; SAR(10 g) = 0.156 W/kg

Maximum value of SAR (measured) = 0.334 W/kg

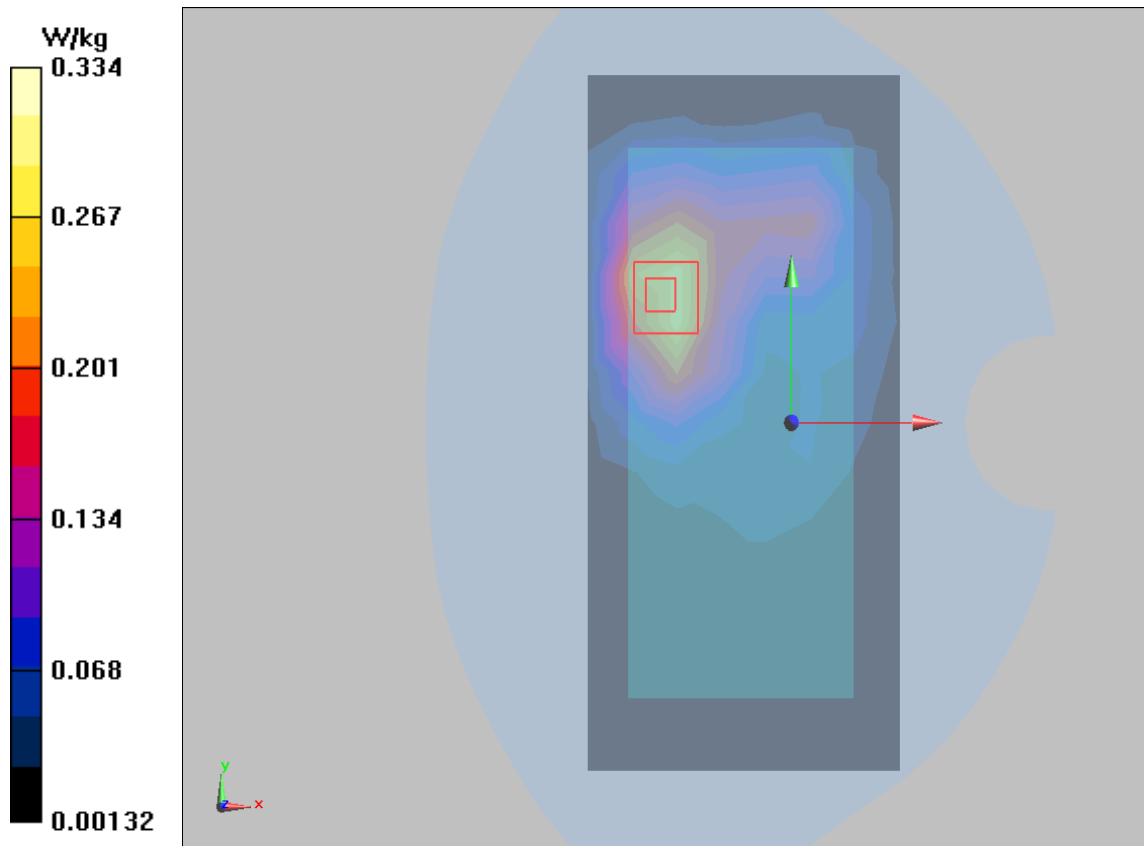

Plot 52 802.11a U-NII-1 Left Cheek Low

Date: 10/9/2020

Communication System: UID 0, 802.11a (0); Frequency: 5180 MHz; Duty Cycle: 1:1.02

Medium parameters used: $f = 5180$ MHz; $\sigma = 4.75$ S/m; $\epsilon_r = 36.766$; $\rho = 1000$ kg/m³

Ambient Temperature: 22.3 °C Liquid Temperature: 21.5 °C

Phantom section: Left Section

DASY5 Configuration:

Sensor-Surface: 1.4mm (Mechanical Surface Detection)

Probe: EX3DV4 - SN3677; ConvF(5.55, 5.55, 5.55); Calibrated: 7/6/2020;

Electronics: DAE4 SN1317; Calibrated: 10/23/2019

Phantom: SAM1; Type: SAM; Serial: TP-1534

Measurement SW: DASY52, Version 52.10 (1); SEMCAD X Version 14.6.11 (7439)

Left Cheek Low/Area Scan (12x21x1): Measurement grid: dx=10mm, dy=10mm

Maximum value of SAR (measured) = 0.731 W/kg

Left Cheek Low /Zoom Scan (7x7x12)/Cube 0: Measurement grid: dx=4mm, dy=4mm, dz=2mm

Reference Value = 5.524 V/m; Power Drift = -0.04 dB

Peak SAR (extrapolated) = 1.61 W/kg

SAR(1 g) = 0.557 W/kg; SAR(10 g) = 0.196 W/kg

Maximum value of SAR (measured) = 0.722 W/kg

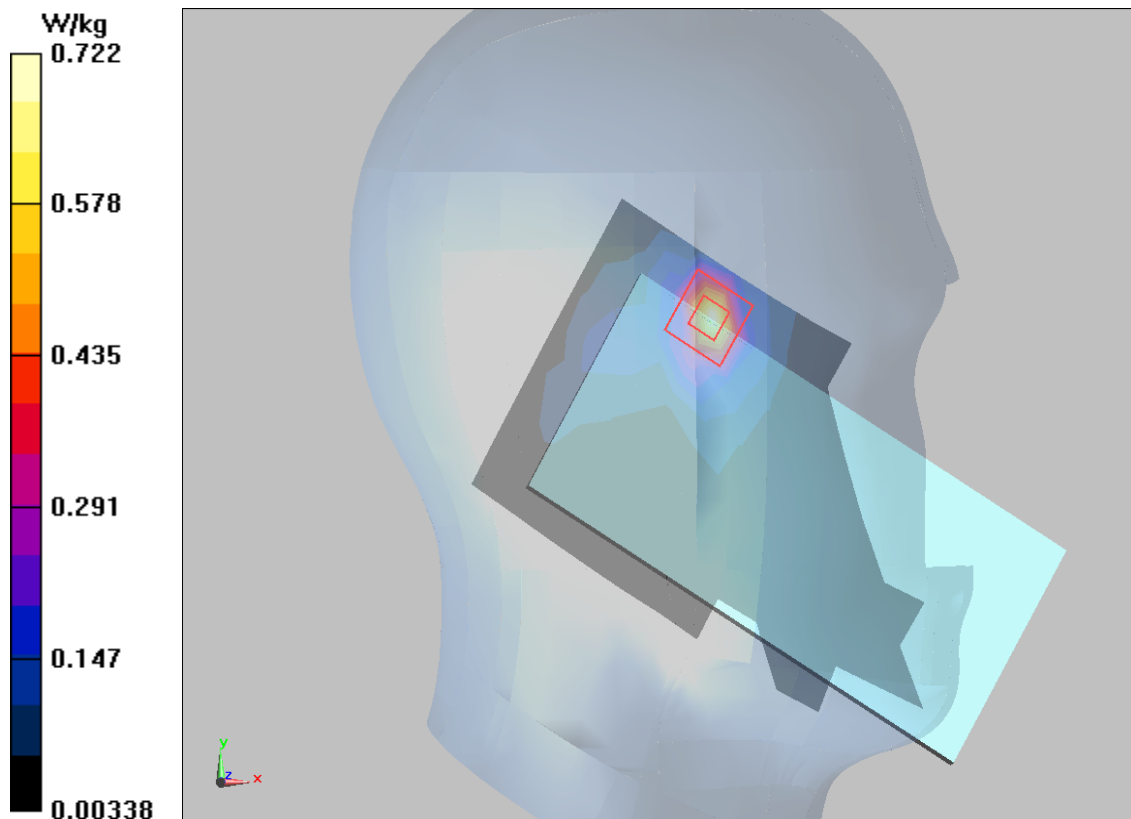

Plot 53 802.11a U-NII-1 Back Side Low (Distance 15mm)

Date: 10/9/2020

Communication System: UID 0, 802.11a (0); Frequency: 5180 MHz; Duty Cycle: 1:1.02

Medium parameters used: $f = 5180 \text{ MHz}$; $\sigma = 4.75 \text{ S/m}$; $\epsilon_r = 36.766$; $\rho = 1000 \text{ kg/m}^3$

Ambient Temperature: $22.3 \text{ }^\circ\text{C}$ Liquid Temperature: $21.5 \text{ }^\circ\text{C}$

Phantom section: Flat Section

DASY5 Configuration:

Sensor-Surface: 1.4mm (Mechanical Surface Detection)

Probe: EX3DV4 - SN3677; ConvF(5.55, 5.55, 5.55); Calibrated: 7/6/2020;

Electronics: DAE4 SN1317; Calibrated: 10/23/2019

Phantom: SAM1; Type: SAM; Serial: TP-1534

Measurement SW: DASY52, Version 52.10 (1); SEMCAD X Version 14.6.11 (7439)

Back Side Middle/Area Scan (12x21x1): Measurement grid: $dx=10\text{mm}$, $dy=10\text{mm}$

Maximum value of SAR (measured) = 0.327 W/kg

Back Side Middl /Zoom Scan (7x7x12)/Cube 0: Measurement grid: $dx=4\text{mm}$, $dy=4\text{mm}$, $dz=2\text{mm}$

Reference Value = 1.109 V/m ; Power Drift = 0.18 dB

Peak SAR (extrapolated) = 1.06 W/kg

SAR(1 g) = 0.382 W/kg ; SAR(10 g) = 0.153 W/kg

Maximum value of SAR (measured) = 0.421 W/kg

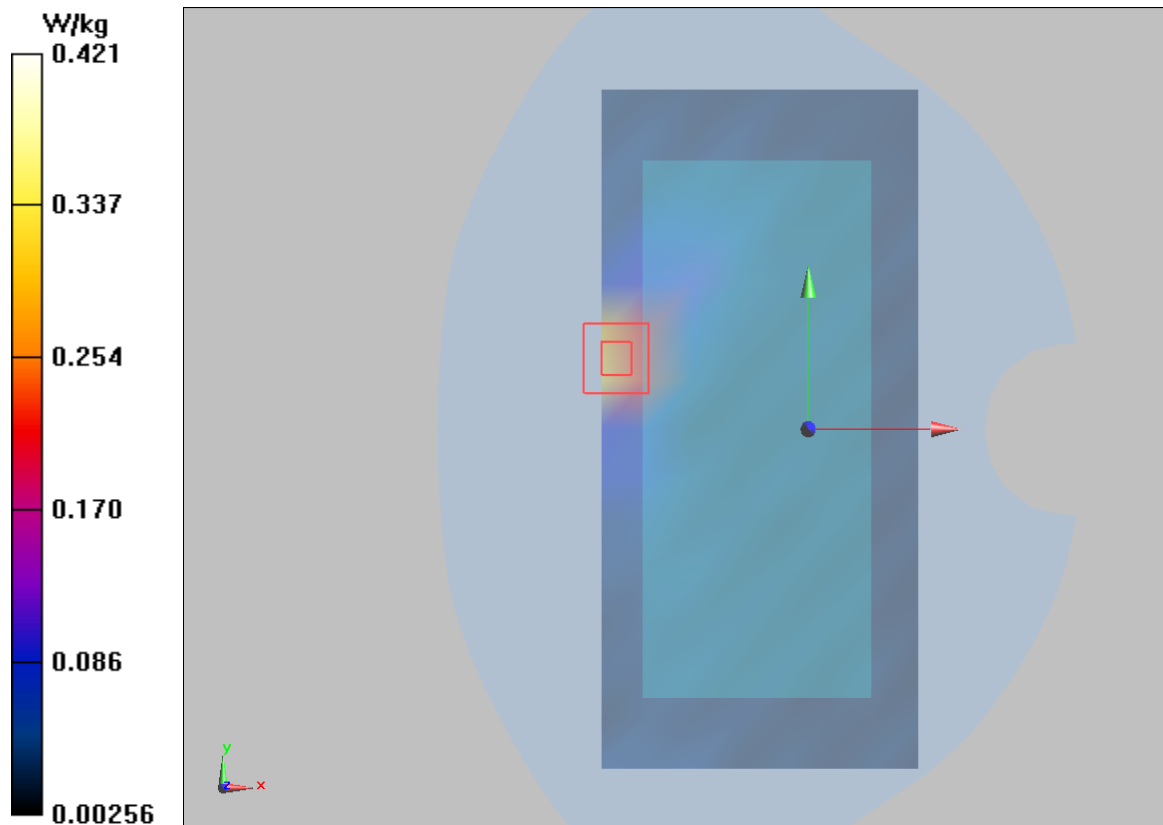

Plot 54 802.11a U-NII-1 Right Edge Low (Distance 10mm)

Date: 10/9/2020

Communication System: UID 0, 802.11a (0); Frequency: 5180 MHz; Duty Cycle: 1:1.02

Medium parameters used: $f = 5180$ MHz; $\sigma = 4.75$ S/m; $\epsilon_r = 36.766$; $\rho = 1000$ kg/m³

Ambient Temperature: 22.3 °C Liquid Temperature: 21.5 °C

Phantom section: Flat Section

DASY5 Configuration:

Sensor-Surface: 1.4mm (Mechanical Surface Detection)

Probe: EX3DV4 - SN3677; ConvF(5.55, 5.55, 5.55); Calibrated: 7/6/2020;

Electronics: DAE4 SN1317; Calibrated: 10/23/2019

Phantom: SAM1; Type: SAM; Serial: TP-1534

Measurement SW: DASY52, Version 52.10 (1); SEMCAD X Version 14.6.11 (7439)

Right Edge Low/Area Scan (5x23x1): Measurement grid: dx=10mm, dy=10mm

Maximum value of SAR (measured) = 0.819 W/kg

Right Edge Low/Zoom Scan (7x7x12)/Cube 0: Measurement grid: dx=4mm, dy=4mm, dz=2mm

Reference Value = 5.238 V/m; Power Drift = -0.023 dB

Peak SAR (extrapolated) = 5.57 W/kg

SAR(1 g) = 1.04 W/kg; SAR(10 g) = 0.351 W/kg

Maximum value of SAR (measured) = 0.936 W/kg

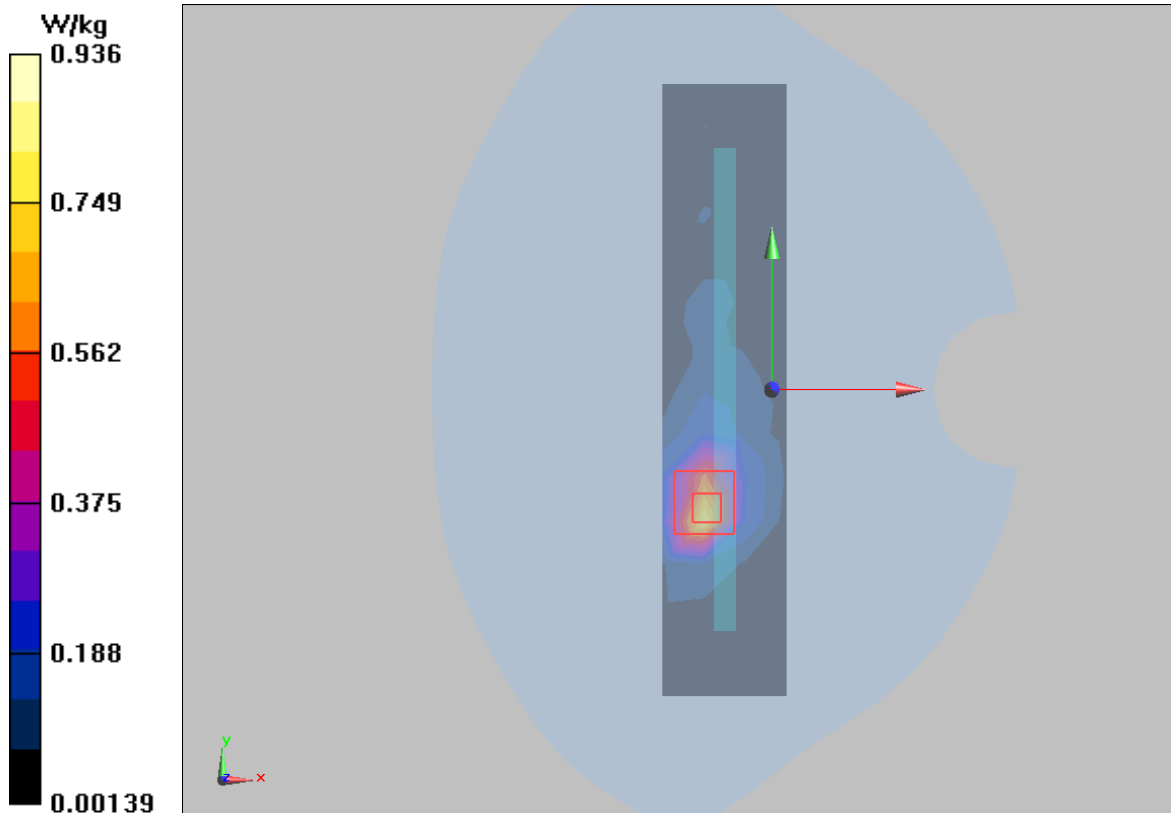

Plot 55 802.11a U-NII-3 Left Cheek High

Date: 10/9/2020

Communication System: UID 0, 802.11a (0); Frequency: 5825 MHz; Duty Cycle: 1:1.02

Medium parameters used: $f = 5825 \text{ MHz}$; $\sigma = 5.48 \text{ S/m}$; $\epsilon_r = 35.186$; $\rho = 1000 \text{ kg/m}^3$

Ambient Temperature: $22.3 \text{ }^\circ\text{C}$ Liquid Temperature: $21.5 \text{ }^\circ\text{C}$

Phantom section: Left Section

DASY5 Configuration:

Sensor-Surface: 1.4mm (Mechanical Surface Detection)

Probe: EX3DV4 - SN3677; ConvF(5.00, 5.00, 5.00); Calibrated: 7/6/2020;

Electronics: DAE4 SN1317; Calibrated: 10/23/2019

Phantom: SAM1; Type: SAM; Serial: TP-1534

Measurement SW: DASY52, Version 52.10 (1); SEMCAD X Version 14.6.11 (7439)

Left Cheek High/Area Scan (12x21x1): Measurement grid: $dx=10\text{mm}$, $dy=10\text{mm}$

Maximum value of SAR (measured) = 0.274 W/kg

Left Cheek High/Zoom Scan (7x7x12)/Cube 0: Measurement grid: $dx=4\text{mm}$, $dy=4\text{mm}$, $dz=2\text{mm}$

Reference Value = 4.535 V/m ; Power Drift = 0.044 dB

Peak SAR (extrapolated) = 0.726 W/kg

SAR(1 g) = 0.236 W/kg ; SAR(10 g) = 0.093 W/kg

Maximum value of SAR (measured) = 0.293 W/kg

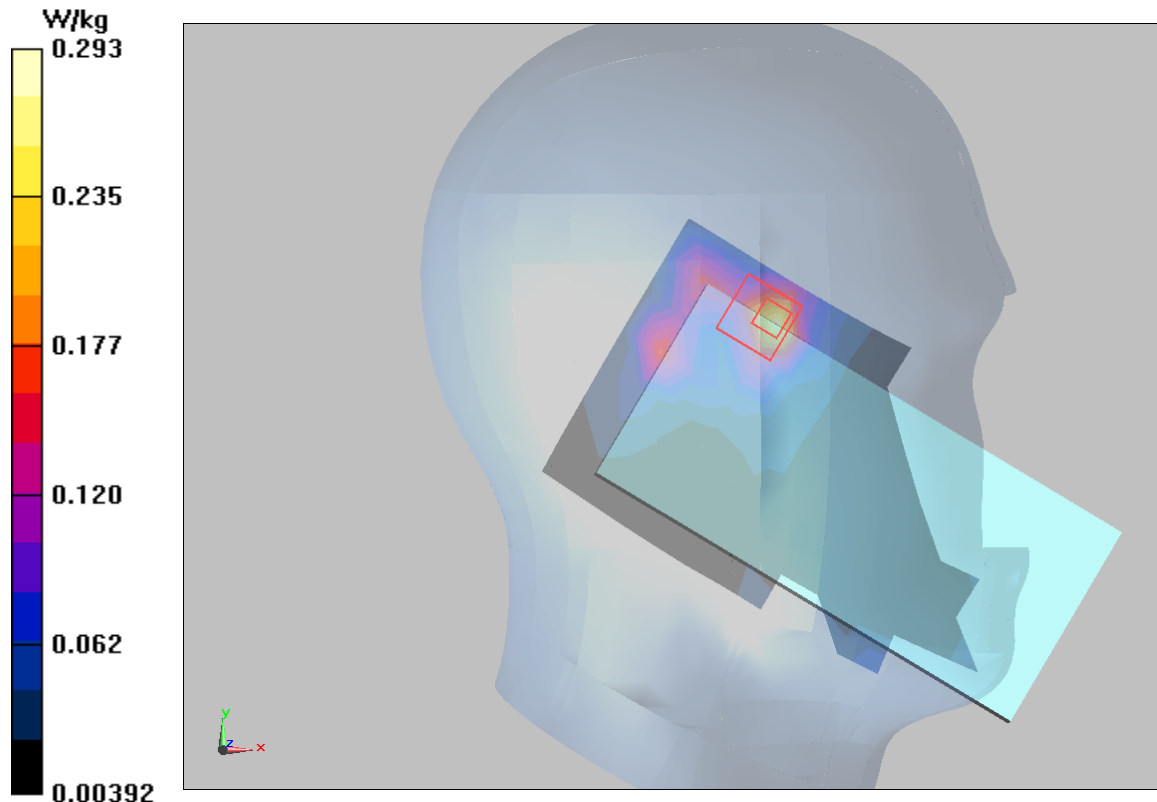

Plot 56 802.11a U-NII-3 Back Side High (Distance 15mm)

Date: 10/9/2020

Communication System: UID 0, 802.11a (0); Frequency: 5825 MHz; Duty Cycle: 1:1.02

Medium parameters used: $f = 5825$ MHz; $\sigma = 5.48$ S/m; $\epsilon_r = 35.186$; $\rho = 1000$ kg/m³

Ambient Temperature: 22.3 °C Liquid Temperature: 21.5 °C

Phantom section: Flat Section

DASY5 Configuration:

Sensor-Surface: 1.4mm (Mechanical Surface Detection)

Probe: EX3DV4 - SN3677; ConvF(5.00, 5.00, 5.00); Calibrated: 7/6/2020;

Electronics: DAE4 SN1317; Calibrated: 10/23/2019

Phantom: SAM1; Type: SAM; Serial: TP-1534

Measurement SW: DASY52, Version 52.10 (1); SEMCAD X Version 14.6.11 (7439)

Back Side High/Area Scan (12x23x1): Measurement grid: dx=10mm, dy=10mm

Maximum value of SAR (measured) = 0.259 W/kg

Back Side High/Zoom Scan (7x7x12)/Cube 0: Measurement grid: dx=4mm, dy=4mm, dz=2mm

Reference Value = 0.4650 V/m; Power Drift = 0.025 dB

Peak SAR (extrapolated) = 0.764 W/kg

SAR(1 g) = 0.246 W/kg; SAR(10 g) = 0.091 W/kg

Maximum value of SAR (measured) = 0.283 W/kg

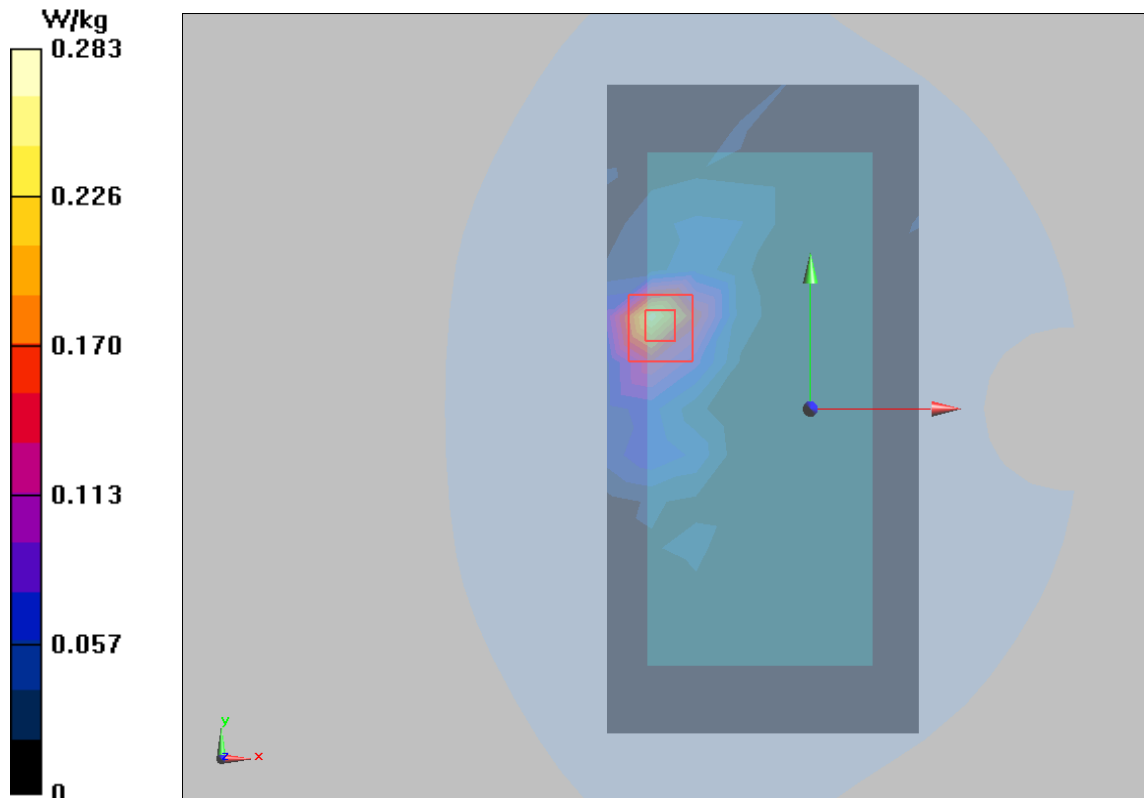

Plot 57 802.11a U-NII-3 Right Edge High (Distance 10mm)

Date: 10/9/2020

Communication System: UID 0, 802.11a (0); Frequency: 5825 MHz; Duty Cycle: 1:1.02

Medium parameters used: $f = 5825$ MHz; $\sigma = 5.48$ S/m; $\epsilon_r = 35.186$; $\rho = 1000$ kg/m³

Ambient Temperature: 22.3 °C Liquid Temperature: 21.5 °C

Phantom section: Flat Section

DASY5 Configuration:

Sensor-Surface: 1.4mm (Mechanical Surface Detection)

Probe: EX3DV4 - SN3677; ConvF(5.00, 5.00, 5.00); Calibrated: 7/6/2020;

Electronics: DAE4 SN1317; Calibrated: 10/23/2019

Phantom: SAM1; Type: SAM; Serial: TP-1534

Measurement SW: DASY52, Version 52.10 (1); SEMCAD X Version 14.6.11 (7439)

Right Edge High/Area Scan (5x23x1): Measurement grid: dx=10mm, dy=10mm

Maximum value of SAR (measured) = 0.494 W/kg

Right Edge High/Zoom Scan (7x7x12)/Cube 0: Measurement grid: dx=4mm, dy=4mm, dz=2mm

Reference Value = 3.038 V/m; Power Drift = 0.060 dB

Peak SAR (extrapolated) = 1.66 W/kg

SAR(1 g) = 0.532 W/kg; SAR(10 g) = 0.183 W/kg

Maximum value of SAR (measured) = 0.576 W/kg

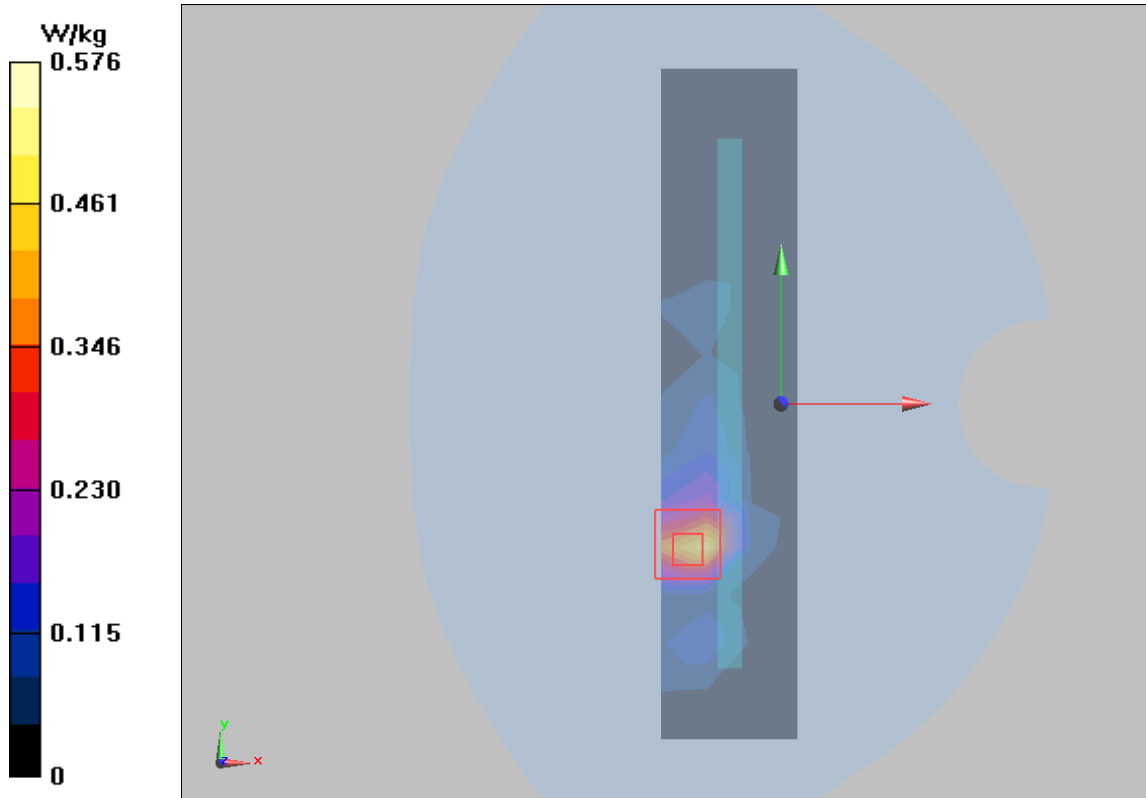

Plot 58 BT Left Cheek High

Date: 9/10/2020

Communication System: UID 0, BT (0); Frequency: 2480 MHz; Duty Cycle: 1:1.297

Medium parameters used: $f = 2480$ MHz; $\sigma = 1.839$ S/m; $\epsilon_r = 39.245$; $\rho = 1000$ kg/m³

Ambient Temperature: 22.3 °C Liquid Temperature: 21.5 °C

Phantom section: Left Section

DASY5 Configuration:

Sensor-Surface: 1.4mm (Mechanical Surface Detection)

Probe: EX3DV4 - SN3677; ConvF(7.54, 7.54, 7.54); Calibrated: 7/6/2020;

Electronics: DAE4 SN1317; Calibrated: 10/23/2019

Phantom: SAM1; Type: SAM; Serial: TP-1534

Measurement SW: DASY52, Version 52.10 (1); SEMCAD X Version 14.6.11 (7439)

Left Cheek High/Area Scan (10x18x1): Measurement grid: dx=12mm, dy=12mm

Maximum value of SAR (measured) = 0.0945 W/kg

Left Cheek High/Zoom Scan (7x7x7)/Cube 0: Measurement grid: dx=5mm, dy=5mm, dz=5mm

Reference Value = 2.770 V/m; Power Drift = 0.069 dB

Peak SAR (extrapolated) = 0.187 W/kg

SAR(1 g) = 0.089 W/kg; SAR(10 g) = 0.043 W/kg

Maximum value of SAR (measured) = 0.097 W/kg

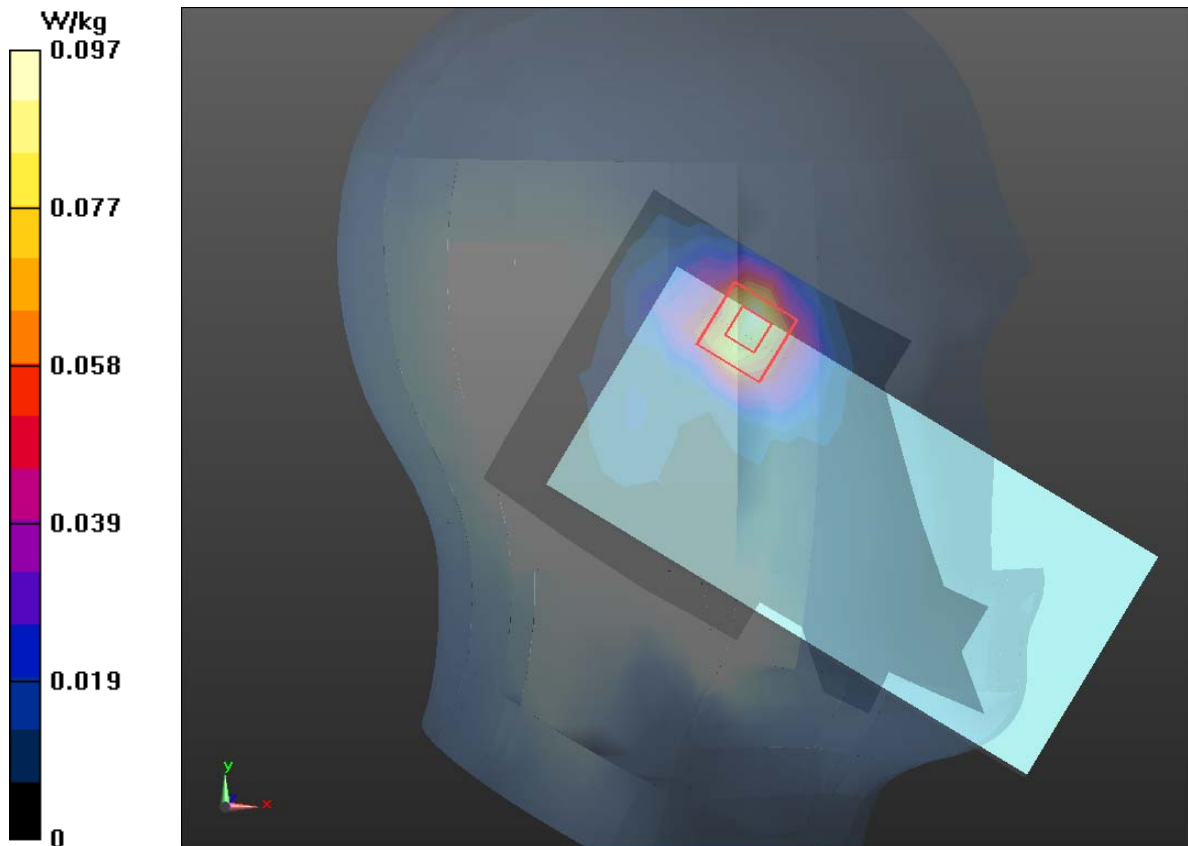

Plot 59 BT Back Side High (Distance 10mm)

Date: 9/10/2020

Communication System: UID 0, BT (0); Frequency: 2480 MHz; Duty Cycle: 1:1.297

Medium parameters used: $f = 2480$ MHz; $\sigma = 1.839$ S/m; $\epsilon_r = 39.245$; $\rho = 1000$ kg/m³

Ambient Temperature: 22.3 °C Liquid Temperature: 21.5 °C

Phantom section: Flat Section

DASY5 Configuration:

Sensor-Surface: 1.4mm (Mechanical Surface Detection)

Probe: EX3DV4 - SN3677; ConvF(7.54, 7.54, 7.54); Calibrated: 7/6/2020;

Electronics: DAE4 SN1317; Calibrated: 10/23/2019

Phantom: SAM1; Type: SAM; Serial: TP-1534

Measurement SW: DASY52, Version 52.10 (1); SEMCAD X Version 14.6.11 (7439)

Back Side High/Area Scan (10x17x1): Measurement grid: dx=12mm, dy=12mm

Maximum value of SAR (measured) = 0.0633 W/kg

Back Side High/Zoom Scan (7x7x7)/Cube 0: Measurement grid: dx=5mm, dy=5mm, dz=5mm

Reference Value = 1.798 V/m; Power Drift = 0.137 dB

Peak SAR (extrapolated) = 0.136 W/kg

SAR(1 g) = 0.061 W/kg; SAR(10 g) = 0.030 W/kg

Maximum value of SAR (measured) = 0.065 W/kg

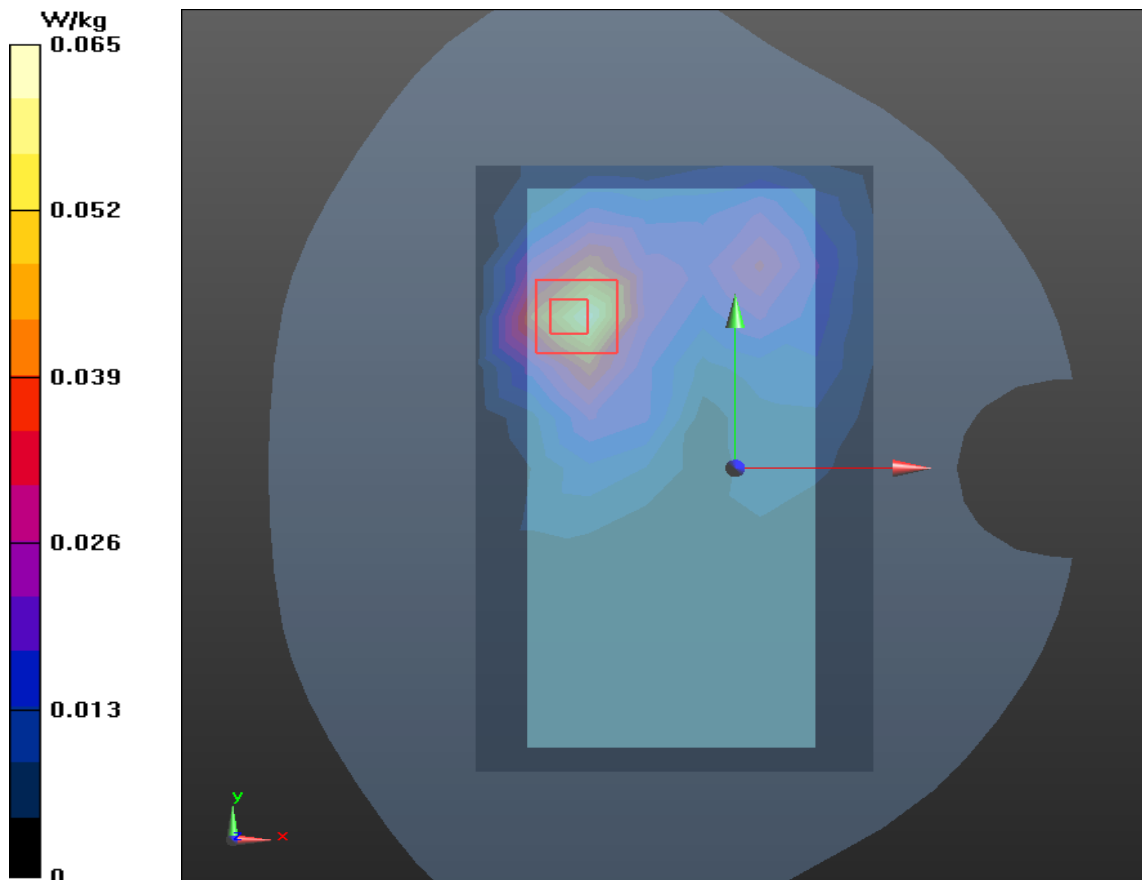

Plot 60 BT Back Side High (Distance 0mm)

Date: 9/10/2020

Communication System: UID 0, BT (0); Frequency: 2480 MHz; Duty Cycle: 1:1.297

Medium parameters used: $f = 2480$ MHz; $\sigma = 1.843$ S/m; $\epsilon_r = 38.464$; $\rho = 1000$ kg/m³

Ambient Temperature: 22.3 °C Liquid Temperature: 21.5 °C

Phantom section: Flat Section

DASY5 Configuration:

Sensor-Surface: 1.4mm (Mechanical Surface Detection)

Probe: EX3DV4 - SN3677; ConvF(7.54, 7.54, 7.54); Calibrated: 7/6/2020;

Electronics: DAE4 SN1317; Calibrated: 10/23/2019

Phantom: SAM1; Type: SAM; Serial: TP-1534

Measurement SW: DASY52, Version 52.10 (1); SEMCAD X Version 14.6.11 (7439)

Back Side High/Area Scan (10x17x1): Measurement grid: dx=12mm, dy=12mm

Maximum value of SAR (measured) = 0.429 W/kg

Back Side High/Zoom Scan (7x7x7)/Cube 0: Measurement grid: dx=5mm, dy=5mm, dz=5mm

Reference Value = 1.453 V/m; Power Drift = -0.025 dB

Peak SAR (extrapolated) = 1.42 W/kg

SAR(1 g) = 0.537 W/kg; SAR(10 g) = 0.236 W/kg

Maximum value of SAR (measured) = 0.563 W/kg

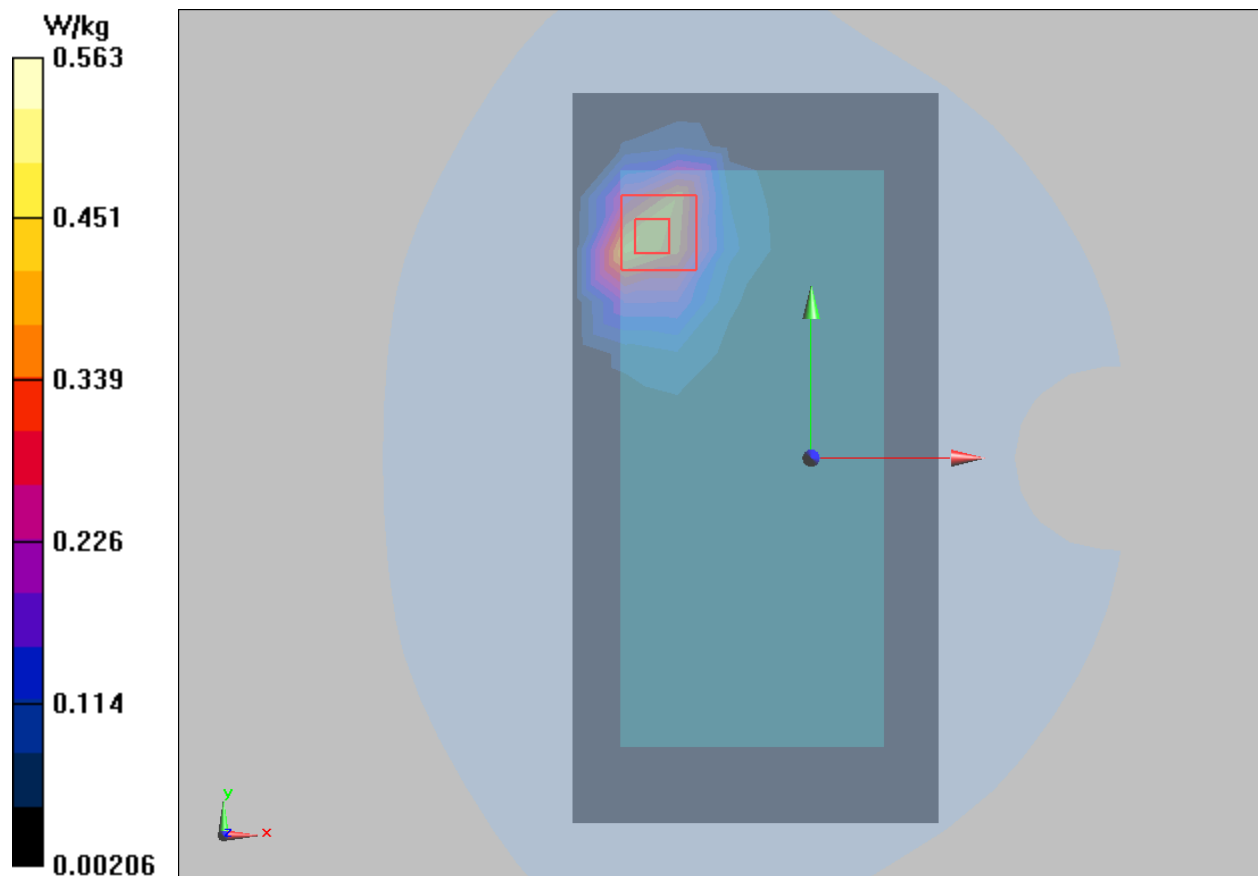



ANNEX D: Probe Calibration Certificate



In Collaboration with
s p e a g
CALIBRATION LABORATORY



中国认可
国际互认
校准
CALIBRATION
CNAS L0570

Add: No.51 Xueyuan Road, Haidian District, Beijing, 100191, China
Tel: +86-10-62304633-2512 Fax: +86-10-62304633-2504
E-mail: cttl@chinattl.com [Http://www.chinattl.cn](http://www.chinattl.cn)

Client **TA(Shanghai)**Certificate No: **Z20-60218****CALIBRATION CERTIFICATE**

Object: **EX3DV4 - SN : 3677**

Calibration Procedure(s): **FF-Z11-004-01**
Calibration Procedures for Dosimetric E-field Probes

Calibration date: **July 06, 2020**

This calibration Certificate documents the traceability to national standards, which realize the physical units of measurements(SI). The measurements and the uncertainties with confidence probability are given on the following pages and are part of the certificate.

All calibrations have been conducted in the closed laboratory facility: environment temperature(22±3)°C and humidity<70%.

Calibration Equipment used (M&TE critical for calibration)

Primary Standards	ID #	Cal Date(Calibrated by, Certificate No.)	Scheduled Calibration
Power Meter NRP2	101919	16-Jun-20(CTTL, No.J20X04344)	Jun-21
Power sensor NRP-Z91	101547	16-Jun-20(CTTL, No.J20X04344)	Jun-21
Power sensor NRP-Z91	101548	16-Jun-20(CTTL, No.J20X04344)	Jun-21
Reference 10dBAttenuator	18N50W-10dB	10-Feb-20(CTTL, No.J20X00525)	Feb-22
Reference 20dBAttenuator	18N50W-20dB	10-Feb-20(CTTL, No.J20X00526)	Feb-22
Reference Probe EX3DV4	SN 3617	30-Jan-20(SPEAG, No.EX3-3617_Jan20/2)	Jan-21
DAE4	SN 1556	4-Feb-20(SPEAG, No.DAE4-1556_Feb20)	Feb-21
Secondary Standards	ID #	Cal Date(Calibrated by, Certificate No.)	Scheduled Calibration
SignalGenerator MG3700A	6201052605	23-Jun-20(CTTL, No.J20X04343)	Jun-21
Network Analyzer E5071C	MY46110673	10-Feb-20(CTTL, No.J20X00515)	Feb-21

	Name	Function	Signature
Calibrated by:	Yu Zongying	SAR Test Engineer	
Reviewed by:	Lin Hao	SAR Test Engineer	
Approved by:	Qi Dianyuan	SAR Project Leader	

Issued: July 08, 2020

This calibration certificate shall not be reproduced except in full without written approval of the laboratory.



In Collaboration with
s p e a g
CALIBRATION LABORATORY

Add: No.51 Xucyuan Road, Haidian District, Beijing, 100191, China
Tel: +86-10-62304633-2512 Fax: +86-10-62304633-2504
E-mail: cttl@chinattl.com [Http://www.chinattl.cn](http://www.chinattl.cn)

Glossary:

TSL	tissue simulating liquid
NORM _{x,y,z}	sensitivity in free space
ConvF	sensitivity in TSL / NORM _{x,y,z}
DCP	diode compression point
CF	crest factor (1/duty_cycle) of the RF signal
A,B,C,D	modulation dependent linearization parameters
Polarization Φ	Φ rotation around probe axis
Polarization θ	θ rotation around an axis that is in the plane normal to probe axis (at measurement center), i $\theta=0$ is normal to probe axis

Connector Angle information used in DASY system to align probe sensor X to the robot coordinate system

Calibration is Performed According to the Following Standards:

- IEEE Std 1528-2013, "IEEE Recommended Practice for Determining the Peak Spatial-Averaged Specific Absorption Rate (SAR) in the Human Head from Wireless Communications Devices: Measurement Techniques", June 2013
- IEC 62209-1, "Measurement procedure for the assessment of Specific Absorption Rate (SAR) from hand-held and body-mounted devices used next to the ear (frequency range of 300 MHz to 6 GHz)", July 2016
- IEC 62209-2, "Procedure to determine the Specific Absorption Rate (SAR) for wireless communication devices used in close proximity to the human body (frequency range of 30 MHz to 6 GHz)", March 2010
- KDB 865664, "SAR Measurement Requirements for 100 MHz to 6 GHz"

Methods Applied and Interpretation of Parameters:

- NORM_{x,y,z}:** Assessed for E-field polarization $\theta=0$ ($f \leq 900\text{MHz}$ in TEM-cell; $f > 1800\text{MHz}$: waveguide). NORM_{x,y,z} are only intermediate values, i.e., the uncertainties of NORM_{x,y,z} does not effect the E^2 -field uncertainty inside TSL (see below ConvF).
- NORM(f)_{x,y,z} = NORM_{x,y,z} * frequency_response** (see Frequency Response Chart). This linearization is implemented in DASY4 software versions later than 4.2. The uncertainty of the frequency response is included in the stated uncertainty of ConvF.
- DCP_{x,y,z}:** DCP are numerical linearization parameters assessed based on the data of power sweep (no uncertainty required). DCP does not depend on frequency nor media.
- PAR:** PAR is the Peak to Average Ratio that is not calibrated but determined based on the signal characteristics.
- A_{x,y,z}; B_{x,y,z}; C_{x,y,z}; VR_{x,y,z}; A,B,C** are numerical linearization parameters assessed based on the data of power sweep for specific modulation signal. The parameters do not depend on frequency nor media. VR is the maximum calibration range expressed in RMS voltage across the diode.
- ConvF and Boundary Effect Parameters:** Assessed in flat phantom using E-field (or Temperature Transfer Standard for $f \leq 800\text{MHz}$) and inside waveguide using analytical field distributions based on power measurements for $f > 800\text{MHz}$. The same setups are used for assessment of the parameters applied for boundary compensation (alpha, depth) of which typical uncertainty valued are given. These parameters are used in DASY4 software to improve probe accuracy close to the boundary. The sensitivity in TSL corresponds to NORM_{x,y,z} * ConvF whereby the uncertainty corresponds to that given for ConvF. A frequency dependent ConvF is used in DASY version 4.4 and higher which allows extending the validity from $\pm 50\text{MHz}$ to $\pm 100\text{MHz}$.
- Spherical isotropy (3D deviation from isotropy):** in a field of low gradients realized using a flat phantom exposed by a patch antenna.
- Sensor Offset:** The sensor offset corresponds to the offset of virtual measurement center from the probe tip (on probe axis). No tolerance required.
- Connector Angle:** The angle is assessed using the information gained by determining the NORM_x (no uncertainty required).

Certificate No:Z20-60218

Page 2 of 9

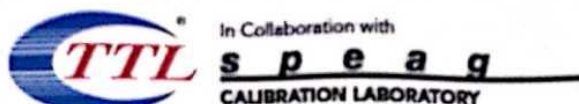

Add: No 51 Xueyuan Road, Haidian District, Beijing, 100191, China
 Tel: +86-10-62304633-2512 Fax: +86-10-62304633-2504
 E-mail: cttl@chinattl.com Http://www.chinattl.cn

DASY/EASY – Parameters of Probe: EX3DV4 – SN:3677

Basic Calibration Parameters

	Sensor X	Sensor Y	Sensor Z	Unc (k=2)
Norm($\mu V/(V/m)^2$) ^A	0.41	0.46	0.40	±10.0%
DCP(mV) ^B	100.7	102.6	102.1	

Modulation Calibration Parameters

UID	Communication System Name		A dB	B dB· μV	C	D dB	VR mV	Unc ^E (k=2)
0	CW	X	0.0	0.0	1.0	0.00	174.8	±2.0%
		Y	0.0	0.0	1.0		186.9	
		Z	0.0	0.0	1.0		173.5	

The reported uncertainty of measurement is stated as the standard uncertainty of Measurement multiplied by the coverage factor $k=2$, which for a normal distribution corresponds to a coverage probability of approximately 95%.

^A The uncertainties of Norm X, Y, Z do not affect the E²-field uncertainty inside TSL (see Page 4).

^B Numerical linearization parameter: uncertainty not required.

^E Uncertainty is determined using the max. deviation from linear response applying rectangular distribution and is expressed for the square of the field value.



Add: No.51 Xueyuan Road, Haidian District, Beijing, 100191, China
 Tel: +86-10-62304633-2512 Fax: +86-10-62304633-2504
 E-mail: cttl@chinattl.com [Http://www.chinattl.cn](http://www.chinattl.cn)

DASY/EASY – Parameters of Probe: EX3DV4 – SN:3677

Calibration Parameter Determined in Head Tissue Simulating Media

f [MHz] ^C	Relative Permittivity ^F	Conductivity (S/m) ^F	ConvF X	ConvF Y	ConvF Z	Alpha ^G	Depth ^G (mm)	Unct. (k=2)
750	41.9	0.89	9.78	9.78	9.78	0.40	0.75	±12.1%
835	41.5	0.90	9.38	9.38	9.38	0.21	1.11	±12.1%
1750	40.1	1.37	8.25	8.25	8.25	0.26	1.05	±12.1%
1900	40.0	1.40	7.90	7.90	7.90	0.28	1.06	±12.1%
2000	40.0	1.40	7.97	7.97	7.97	0.23	1.17	±12.1%
2300	39.5	1.67	7.69	7.69	7.69	0.66	0.68	±12.1%
2450	39.2	1.80	7.54	7.54	7.54	0.66	0.70	±12.1%
2600	39.0	1.96	7.26	7.26	7.26	0.74	0.67	±12.1%
3300	38.2	2.71	7.07	7.07	7.07	0.48	0.97	±13.3%
3500	37.9	2.91	7.03	7.03	7.03	0.49	0.93	±13.3%
3700	37.7	3.12	6.83	6.83	6.83	0.49	0.97	±13.3%
3900	37.5	3.32	6.76	6.76	6.76	0.40	1.20	±13.3%
4100	37.2	3.53	6.78	6.78	6.78	0.40	1.15	±13.3%
4400	36.9	3.84	6.47	6.47	6.47	0.40	1.20	±13.3%
4600	36.7	4.04	6.42	6.42	6.42	0.50	1.13	±13.3%
4800	36.4	4.25	6.35	6.35	6.35	0.45	1.25	±13.3%
4950	36.3	4.40	6.22	6.22	6.22	0.45	1.25	±13.3%
5250	35.9	4.71	5.55	5.55	5.55	0.50	1.15	±13.3%
5600	35.5	5.07	4.97	4.97	4.97	0.55	1.22	±13.3%
5750	35.4	5.22	5.00	5.00	5.00	0.55	1.27	±13.3%

^C Frequency validity above 300 MHz of ±100MHz only applies for DASY v4.4 and higher (Page 2), else it is restricted to ±50MHz. The uncertainty is the RSS of ConvF uncertainty at calibration frequency and the uncertainty for the indicated frequency band. Frequency validity below 300 MHz is ± 10, 25, 40, 50 and 70 MHz for ConvF assessments at 30, 64, 128, 150 and 220 MHz respectively. Above 5 GHz frequency validity can be extended to ± 110 MHz.

^F At frequency below 3 GHz, the validity of tissue parameters (ϵ and σ) can be relaxed to ±10% if liquid compensation formula is applied to measured SAR values. At frequencies above 3 GHz, the validity of tissue parameters (ϵ and σ) is restricted to ±5%. The uncertainty is the RSS of the ConvF uncertainty for indicated target tissue parameters.

^G Alpha/Depth are determined during calibration. SPEAG warrants that the remaining deviation due to the boundary effect after compensation is always less than ± 1% for frequencies below 3 GHz and below ± 2% for the frequencies between 3-6 GHz at any distance larger than half the probe tip diameter from the boundary.

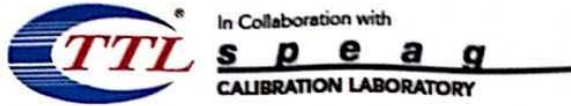

Add: No.51 Xueyuan Road, Haidian District, Beijing, 100191, China
Tel: +86-10-62304633-2512 Fax: +86-10-62304633-2504
E-mail: cttl@chinattl.com [Http://www.chinattl.cn](http://www.chinattl.cn)

Frequency Response of E-Field (TEM-Cell: ifi110 EXX, Waveguide: R22)

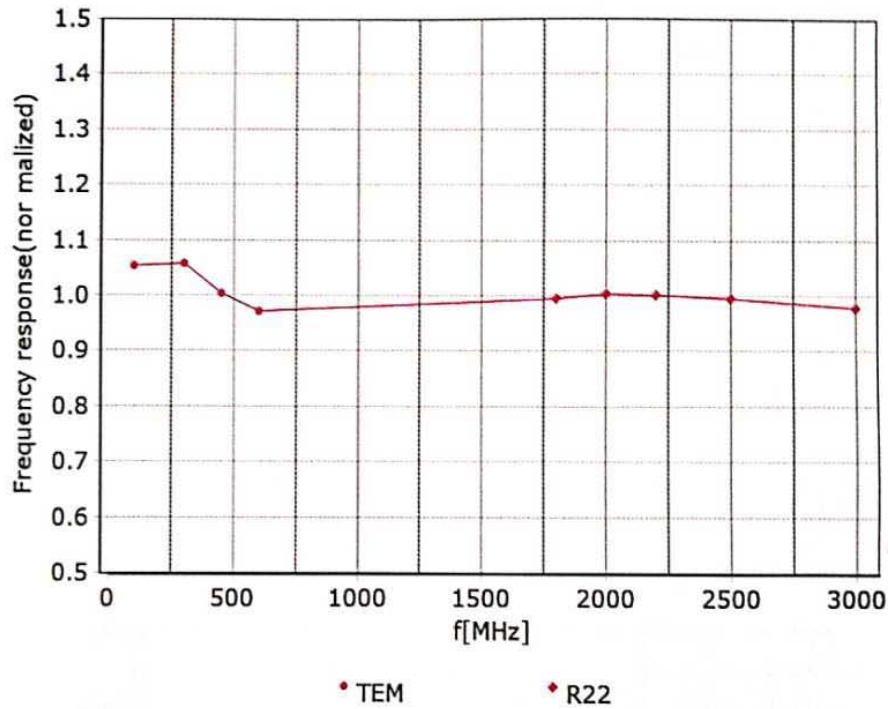

Uncertainty of Frequency Response of E-field: $\pm 7.4\%$ ($k=2$)

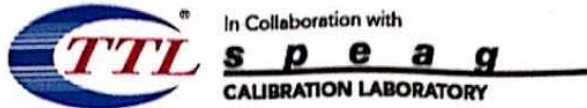

Add: No.51 Xueyuan Road, Haidian District, Beijing, 100191, China
 Tel: +86-10-62304633-2512 Fax: +86-10-62304633-2504
 E-mail: cttl@chinattl.com Http://www.chinattl.cn

Receiving Pattern (Φ), $\theta=0^\circ$

f=600 MHz, TEM

f=1800 MHz, R22

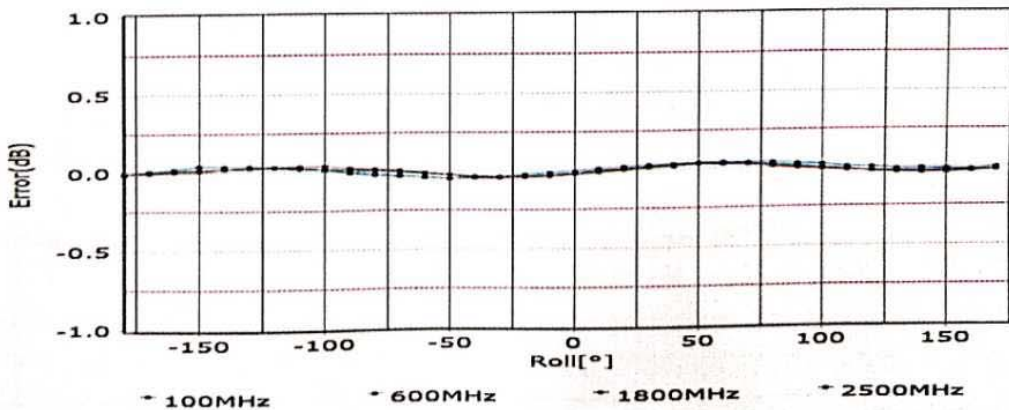
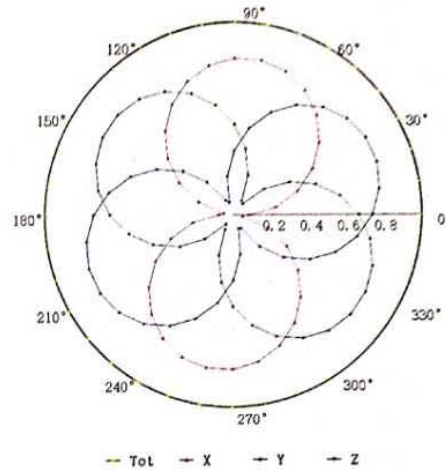
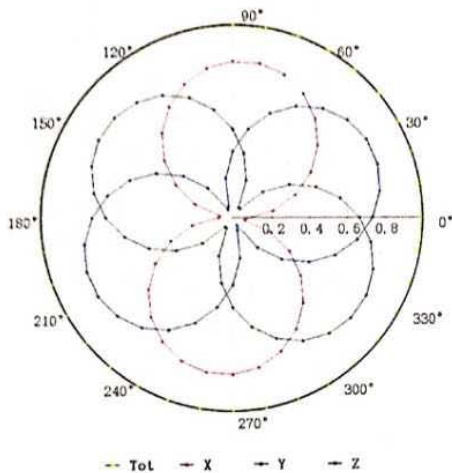

Uncertainty of Axial Isotropy Assessment: $\pm 1.2\%$ ($k=2$)

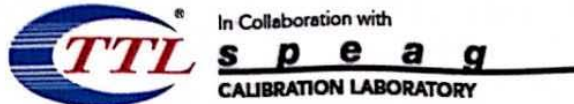

Add: No.51 Xueyuan Road, Haidian District, Beijing, 100191, China
 Tel: +86-10-62304633-2512 Fax: +86-10-62304633-2504
 E-mail: cttl@chinattl.com [Http://www.chinattl.cn](http://www.chinattl.cn)

Dynamic Range f(SAR_{head}) (TEM cell, f = 900 MHz)

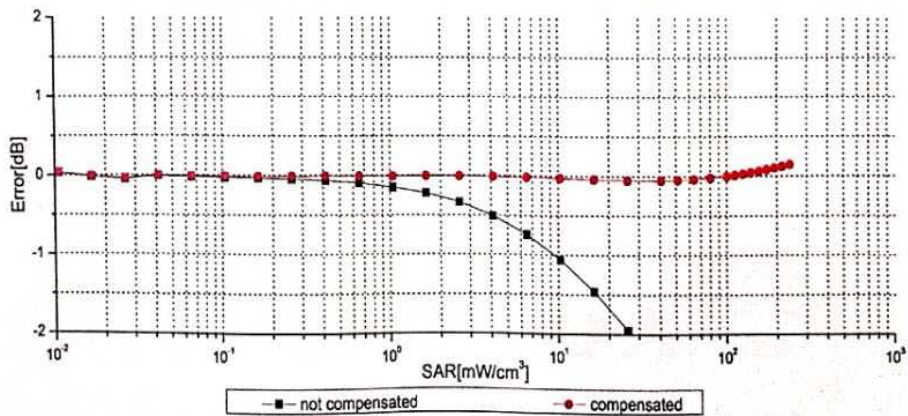
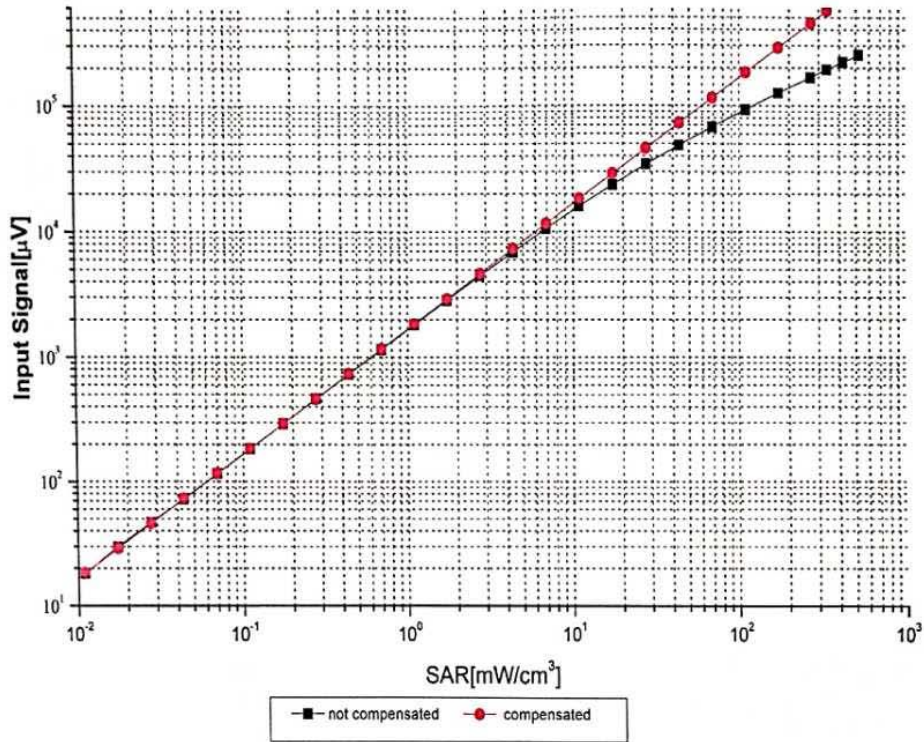

Uncertainty of Linearity Assessment: ±0.9% (k=2)



In Collaboration with
s p e a g
CALIBRATION LABORATORY

Add: No.51 Xueyuan Road, Haidian District, Beijing, 100191, China
Tel: +86-10-62304633-2512 Fax: +86-10-62304633-2504
E-mail: cttl@chinattl.com [Http://www.chinattl.cn](http://www.chinattl.cn)

Conversion Factor Assessment

f=750 MHz,WGLS R9(H_convF)

f=1750 MHz,WGLS R22(H_convF)

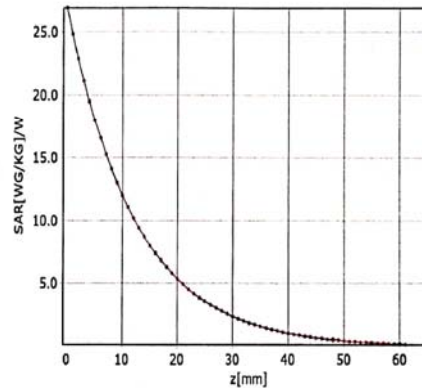
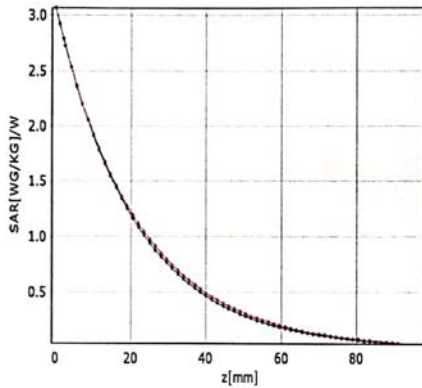

Deviation from Isotropy in Liquid

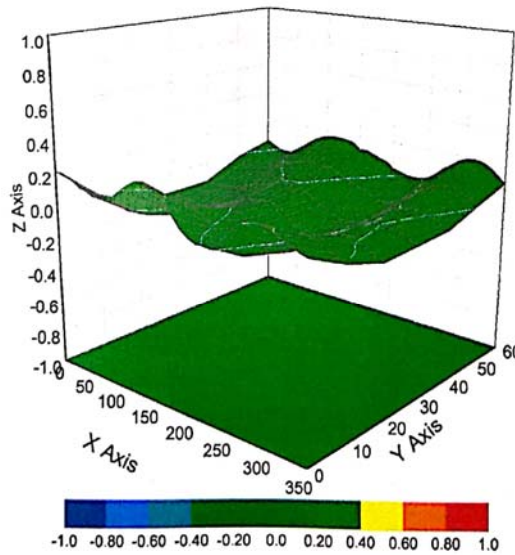

Uncertainty of Spherical Isotropy Assessment: $\pm 3.2\%$ ($k=2$)