

ZTETM BLADETM A7^P

Quick Start Guide

LEGAL INFORMATION

Copyright © 2021 ZTE CORPORATION.

All rights reserved.

No part of this publication may be quoted, reproduced, translated or used in any form or by any means, electronic or mechanical, including photocopying and microfilm, without the prior written permission of ZTE Corporation.

Notice

ZTE Corporation reserves the right to make modifications on print errors or update specifications in this guide without prior notice.

We offer self-service for our smart terminal device users. Please visit the ZTE official website (at www.ztedevices.com) for more information on user manual, self-service and supported product models. Information on the website takes precedence.

Disclaimer

ZTE Corporation expressly disclaims any liability for faults and damages caused by unauthorized modifications of the software. Images and screenshots used in this guide may differ from the actual product. Content in this guide may differ from the actual product or software.

Trademarks

ZTE and the ZTE logos are trademarks of ZTE Corporation.

AndroidTM is a trademark of Google LLC.

The Bluetooth[®] word mark and logos are registered trademarks owned by the Bluetooth SIG, Inc. and any use of such marks by ZTE Corporation is under license.



microSDXC Logo is a trademark of SD-3C, LLC.

Other trademarks and trade names are those of their respective owners.

Version No.: R1.0

Edition Time :September 1, 2021

Getting to Know Your Phone

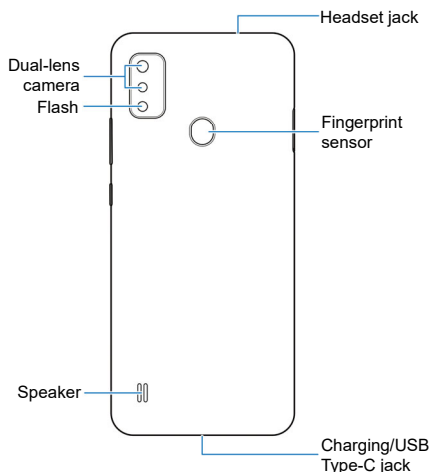
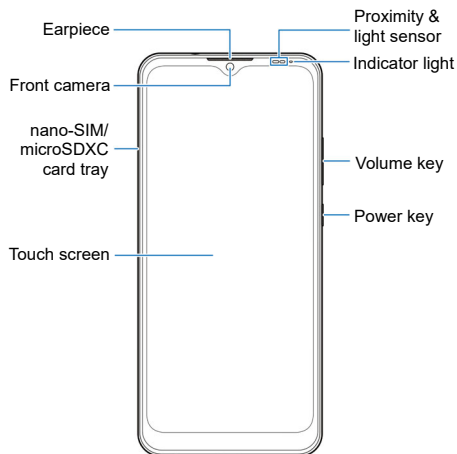

Setting Up Your Phone

The nano-SIM card can be installed or removed while the phone is turned on.

⚠ WARNING!

To avoid damage to the phone, do not use any other kind of SIM cards, or any non-standard nano-SIM card cut from a SIM card. You can get a standard nano-SIM card from your service provider.

1. Insert the tip of the tray eject tool into the hole on the card tray.

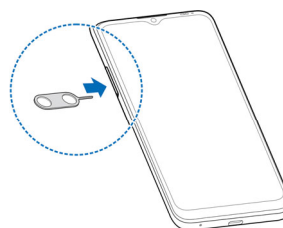

⚠ CAUTION:

Never replace the included tray eject tool with sharp objects. Ensure that the tray eject tool is perpendicular to the hole. Otherwise, the phone may be damaged.

2. Pull out the card tray. You can place a nano-SIM card on the right card slot and a microSDXC card (optional) on the left card slot, as shown. Carefully slide the tray back into place.

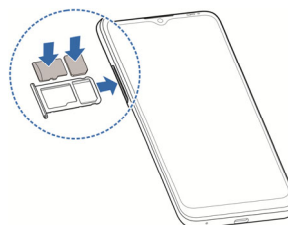

Charging the Phone

Your phone's battery should have enough power for the phone to turn on, find a signal, and make a few calls. You should fully charge the battery as soon as possible.

⚠️ WARNING!

Use only ZTE-approved chargers and USB Type-C cables. The use of unapproved accessories could damage your phone or cause the battery to explode.

⚠️ WARNING!

Do not remove the back cover. The battery is not removable. Removal may cause fire or explosion.

1. Connect the adapter to the charging jack.

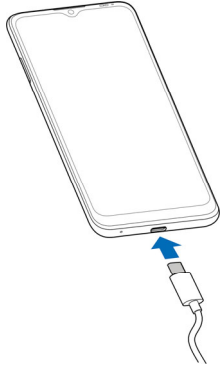

2. Connect the charger to a standard AC power outlet.
3. Disconnect the charger when the battery is fully charged.

✔️ NOTE:

If the battery is extremely low, you may be unable to power on the phone even when it is being charged. In this case, try again after charging the phone for at least 20 minutes. Contact the customer service if you still cannot power on the phone after prolonged charging.

Powering On/Off Your Phone

Make sure the battery is charged before powering on.

- Press and hold the **Power** key to turn on your phone.
- To power off, press and hold the **Power** key to open the options menu, and touch 

✔️ NOTE:

If the screen freezes or takes too long to respond, try pressing and holding the **Power** key for about 10 seconds to restart the phone.

Waking Up Your Phone

Your phone automatically goes into sleep mode when it is not in use for some time. The display is turned off to save power and the keys are locked to prevent accidental operations.







You can wake up your phone by turning on the display and unlocking the keys.





1. Press the **Power** key to turn the screen on.
2. Swipe up on the screen.

✔️ NOTE:

If you have set a fingerprint, a face recognition, an unlock pattern, a PIN or a password for your phone, you'll need to use your fingerprint or face, draw the pattern, or enter the PIN/password to unlock.

Product Safety Information

	Don't make or receive phone calls while driving. Never text while driving.
	Keep your phone at least 15 mm away from your body while making calls.
	Small parts may cause choking.
	Your phone can produce a loud sound.
	To prevent possible hearing damage, do not listen at high volume levels for long periods. Exercise caution when holding your phone near your ear while the loudspeaker is in use.
	Avoid contact with anything magnetic.

	Keep away from pacemakers and other electronic medical devices.
	Turn off when asked to in hospitals and medical facilities.
	Turn off when told to on aircraft and at airports.
	Turn off when near explosive materials or liquids.
	Don't use at gas stations.
	Your phone may produce a bright or flashing light.
	Don't dispose of your phone in fire.
	Avoid extreme temperatures.
	Avoid contact with liquids. Keep your phone dry.
	Do not attempt to disassemble your phone.
	Only use approved accessories.
	Don't rely on your phone as a primary device for emergency communications.

FCC RF Exposure Information (SAR)

This phone is designed and manufactured not to exceed the emission limits for exposure to radio frequency (RF) energy set by the Federal Communications Commission of the United States and Industry Canada of Canada.

During SAR testing, this device was set to transmit at its highest certified power level in all tested frequency bands, and placed in positions that simulate RF exposure in usage against the head with no separation, and near the body with the separation of 15 mm. Although the SAR is

determined at the highest certified power level, the actual SAR level of the device while operating can be well below the maximum value. This is because the phone is designed to operate at multiple power levels so as to use only the power required to reach the network. In general, the closer you are to a wireless base station antenna, the lower the power output.

The exposure standard for wireless devices employing a unit of measurement is known as the Specific Absorption Rate, or SAR. The SAR limit set by the FCC is 1.6 W/kg and 1.6 W/kg by Industry Canada.

This device is in compliance with SAR for general population/uncontrolled exposure limits in ANSI/IEEE C95.1-1992 and Canada RSS 102 and had been tested in accordance with the measurement methods and procedures specified in IEEE1528 and Canada RSS 102. This device has been tested and meets the FCC and IC RF exposure guidelines when tested with the device directly contacted to the body.

The FCC has granted an Equipment Authorization for this model phone with all reported SAR levels evaluated as in compliance with the FCC RF exposure guidelines. SAR information on this model phone is on file with the FCC and can be found under the Display Grant section of www.fcc.gov/oet/ea/fccid after searching on FCC ID: SRQ-Z6252CA.

For this device, the highest reported SAR value for usage against the head is 1.123W/kg and for usage near the body is 1.428 W/kg.

While there may be differences between the SAR levels of various phones and at various positions, they all meet the government requirements.

SAR compliance for body-worn operation is based on a separation distance of 15 mm between the unit and the human body. Carry this device at least 15 mm away from your body to ensure RF exposure level compliant or

lower to the reported level. To support body-worn operation, choose the belt clips or holsters, which do not contain metallic components, to maintain a separation of 15 mm between this device and your body.

RF exposure compliance with any body-worn accessory, which contains metal, was not tested and certified, and using such body-worn accessory should be avoided.

Hearing aid compatibility (HAC) regulations for mobile phones

In 2003, the FCC adopted rules to make digital wireless telephones compatible with hearing aids and cochlear implants. Although analog wireless phones do not usually cause interference with hearing aids or cochlear implants, digital wireless phones sometimes do because of electromagnetic energy emitted by the phone's antenna, backlight, or other components. Your phone is compliant with FCC HAC regulations (ANSI C63.19- 2011).

While some wireless phones are used near some hearing devices (hearing aids and cochlear implants), users may detect a buzzing, humming, or whining noise. Some hearing devices are more immune than others to this interference noise and phones also vary in the amount of interference they generate. The wireless telephone industry has developed a rating system for wireless phones to assist hearing device users in finding phones that may be compatible with their hearing devices. Not all phones have been rated. Phones that are rated have the rating on their box or a label located on the box. These ratings are not guaranteed. Results will vary, depending on the level of immunity of your hearing device and the degree of your hearing loss. If your hearing device happens to be vulnerable to interference, you may not be able to use a rated phone successfully. Trying out the

9

IC Notice

This device complies with Industry Canada license-exempt RSS standard(s). Operation is subject to the following two conditions: (1) this device may not cause interference, and (2) this device must accept any interference, including interference that may cause undesired operation of the device.

This Class B digital apparatus complies with Canadian ICES-003.

IC: 5200E-Z6252CA

IC Radiation Exposure Statement

This EUT is in compliance with SAR for general population/uncontrolled exposure limits in IC RSS-102 and had been tested in accordance with the measurement methods and procedures specified in IEEE 1528 and IEC 62209. This equipment should be installed and operated with minimum distance of 1.5 cm between the radiator and your body.

This device and its antenna(s) must not be co-located or operating in conjunction with any other antenna or transmitter.

Avis d'Industrie Canada

Cet appareil respecte les normes CNR d'Industrie Canada sur l'exemption de licence. Son fonctionnement est soumis aux deux conditions suivantes : (1) l'appareil ne doit pas produire de brouillage; (2) l'appareil doit accepter tout brouillage radioélectrique, même si le brouillage est susceptible de compromettre le fonctionnement de l'appareil.

Cet appareil numérique de classe B est conforme à la norme canadienne ICES-003.

IC : 5200E-Z6252CA

Déclaration d'exposition aux radiations d'IC

11

phone with your hearing device is the best way to evaluate it for your personal needs.

This phone has been tested and rated for use with hearing aids for some of the wireless technologies that it uses. However, there may be some newer wireless technologies used in this phone that have not been tested yet for use with hearing aids. It is important to try the different features of this phone thoroughly and in different locations, using your hearing aid or cochlear implant, to determine if you hear any interfering noise. Consult your service provider or the manufacturer of this phone for information on hearing aid compatibility. If you have questions about return or exchange policies, consult your service provider or phone retailer.

M-Ratings: Phones rated M3 or M4 meet FCC requirements and are likely to generate less interference to hearing devices than phones that are not labeled. M4 is the better/higher of the two ratings.

T-Ratings: Phones rated T3 or T4 meet FCC requirements and are likely to be more usable with a hearing device's telecoil ("T Switch" or "Telephone Switch") than unrated phones. T4 is the better/higher of the two ratings. (Note that not all hearing devices contain telecoils.)

Your SRQ-Z6252CA has been tested for hearing aid device compatibility and has an M4/T3 rating.

Hearing devices may also be measured for immunity to this type of interference. Your hearing device manufacturer or hearing health professional may help you find results for your hearing device.

For additional information about the FCC's actions with regard to hearing aid compatible wireless devices and other steps the FCC has taken to ensure that individuals with disabilities have access to telecommunications services, please go to www.fcc.gov/cgb/dro.

10

Ce matériel à l'essai (MAE) est conforme au DAS et répond aux limites d'exposition non contrôlée pour une utilisation par le grand public selon la norme CNR-102 d'IC. Il a été testé conformément aux méthodes et aux modes opératoires de mesure spécifiés dans la norme IEEE 1528 et la norme de la CEI 62209. Cet équipement doit être installé et utilisé à une distance d'au moins 1,5 cm entre le radiateur et votre corps. Cet appareil et ses antennes ne doivent pas se trouver près d'une autre antenne ou d'un autre équipement utilisé avec de tels équipements.

12