



RF TEST REPORT

Applicant ZTE Corporation
FCC ID SRQ-Z6251
Product LTE/WCDMA/GSM
Multi-Mode Digital MobilePhone
Model Z6251
Report No. R2108A0760-R6V1
Issue Date October 27, 2021

TA Technology (Shanghai) Co., Ltd. tested the above equipment in accordance with the requirements in **FCC CFR47 Part 15E (2020)**. The test results show that the equipment tested is capable of demonstrating compliance with the requirements as documented in this report.

Prepared by: Peng Tao

Approved by: Kai Xu

TA Technology (Shanghai) Co., Ltd.

No.145, Jintang Rd, Tangzhen Industry Park, Pudong Shanghai, China

TEL: +86-021-50791141/2/3

FAX: +86-021-50791141/2/3-8000



TABLE OF CONTENT

1. Test Laboratory	5
1.1. Notes of the test report.....	5
1.2. Test facility	5
1.3. Testing Location.....	5
2. General Description of Equipment under Test.....	6
2.1. Applicant and Manufacturer Information.....	6
2.2. General information.....	6
3. Applied Standards	8
4. Test Configuration	9
5. Test Case Results	11
5.1. Occupied Bandwidth	11
5.2. Average Power Output.....	22
5.3. Frequency Stability.....	27
5.4. Power Spectral Density.....	30
5.5. Unwanted Emission	39
5.6. Conducted Emission	87
6. Main Test Instruments.....	90
ANNEX A: The EUT Appearance	91
ANNEX B: Test Setup Photos	92



Version	Revision description	Issue Date
Rev.0	Initial issue of report.	October 22, 2021
Rev.1	Update description in page 7.	October 27, 2021

Note: This revised report (Report No. R2108A0760-R6V1) supersedes and replaces the previously issued report (Report No. R2108A0760-R6). Please discard or destroy the previously issued report and dispose of it accordingly.

Summary of measurement results

Number	Test Case	Clause in FCC rules	Verdict
1	Average output power	15.407(a)	PASS
2	Occupied bandwidth	15.407(e)	PASS
3	Frequency stability	15.407(g)	PASS
4	Power spectral density	15.407(a)	PASS
5	Unwanted Emissions	15.407(b)	PASS
6	Conducted Emissions	15.207	PASS

Date of Testing: September 2, 2021 ~ October 15, 2021
Date of Sample Received: August 27, 2021

Note: PASS: The EUT complies with the essential requirements in the standard.
FAIL: The EUT does not comply with the essential requirements in the standard.
All indications of Pass/Fail in this report are opinions expressed by TA Technology (Shanghai) Co., Ltd. based on interpretations and/or observations of test results. Measurement Uncertainties were not taken into account and are published for informational purposes only.



1. Test Laboratory

1.1. Notes of the test report

This report shall not be reproduced in full or partial, without the written approval of **TA technology (shanghai) co., Ltd.** The results documented in this report apply only to the tested sample, under the conditions and modes of operation as described herein. Measurement Uncertainties were not taken into account and are published for informational purposes only. This report is written to support regulatory compliance of the applicable standards stated above.

1.2. Test facility

FCC (Designation number: CN1179, Test Firm Registration Number: 446626)

TA Technology (Shanghai) Co., Ltd. has been listed on the US Federal Communications Commission list of test facilities recognized to perform electromagnetic emissions measurements.

A2LA (Certificate Number: 3857.01)

TA Technology (Shanghai) Co., Ltd. has been listed by American Association for Laboratory Accreditation to perform electromagnetic emission measurement.

1.3. Testing Location

Company: TA Technology (Shanghai) Co., Ltd.
Address: No.145, Jintang Rd, Tangzhen Industry Park, Pudong
City: Shanghai
Post code: 201201
Country: P. R. China
Contact: Xu Kai
Telephone: +86-021-50791141/2/3
Fax: +86-021-50791141/2/3-8000
Website: <http://www.ta-shanghai.com>
E-mail: xukai@ta-shanghai.com

2. General Description of Equipment under Test

2.1. Applicant and Manufacturer Information

Applicant	ZTE Corporation
Applicant address	ZTE Plaza, Keji Road South, Hi-Tech, Industrial Park, Nanshan District, Shenzhen, Guangdong, 518057, P.R.China
Manufacturer	ZTE Corporation
Manufacturer address	ZTE Plaza, Keji Road South, Hi-Tech, Industrial Park, Nanshan District, Shenzhen, Guangdong, 518057, P.R.China

2.2. General information

EUT Description	
Model	Z6251
IMEI	862947050003473
Hardware Version	Z6251HW1.0
Software Version	Z6251_CCv1.0.0B08
Power Supply	Battery / AC adapter
Antenna Type	Internal Antenna
Antenna Gain	1.98dBi
Directional Gain	NA
Operating Frequency Range(s)	U-NII-1: 5150MHz-5250MHz U-NII-3: 5725MHz -5850MHz
Modulation Type	802.11a/n (HT20/HT40) : OFDM 802.11ac (VHT20/VHT40/VHT80): OFDM
Max. Conducted Power	14.76 dBm
Extreme temperature range:	-20 ° C to 50° C
Operating temperature range:	-10 ° C to +55° C
Operating voltage range:	3.5 V to 4.43 V
State DC voltage:	3.85V
EUT Accessory	
Adapter 1	Manufacturer: Jiangsu Chenyang Electron Co., Ltd. Model: STC-A520A-Z
Adapter 2	Manufacturer: Shenzhen Ruijing Industrial Co Ltd Model: STC-A520A-Z
Battery	Manufacturer: SCUD (Fujian) Electronics Co., LTD. Model: Li3839T44P8h866445
USB Cable 1	Manufacturer: kingpower-tech



	Model: USB-TC20-W-100-M-L 100cm Cable, Shielded
USB Cable 2	Manufacturer: Shenzhen Luxshare Precision Industry Co.,Ltd. Model: USB-TC20-W-100-M-L 100cm Cable, Shielded
<p>Note: 1. The EUT is sent from the applicant to TA and the information of the EUT is declared by the applicant.</p> <p>2. This device support automatically discontinue transmission, while the device is not transmitting any information, the device can automatically discontinue transmission and become standby mode for power saving. The device can detect the controlling signal of ACK message transmitting from remote device and verify whether it shall resend or discontinue transmission.</p> <p>3. There are more than one Adapter and USB Cable, each one should be applied throughout the compliance test respectively, however, only the worst case (Adapter 2 and USB Cable 2) will be recorded in this report.</p>	



3. Applied Standards

According to the specifications of the manufacturer, it must comply with the requirements of the following standards:

Test standards:

FCC CFR47 Part 15E (2020) Unlicensed National Information Infrastructure Devices

ANSI C63.10 (2013)

Reference standard:

KDB 789033 D02 General UNII Test Procedures New Rules v02r01

4. Test Configuration

Test Mode

The EUT has been associated with peripherals and configuration operated in a manner tended to maximize its emission characteristics in a typical application.

The radiated emission was measured in the following position: EUT stand-up position (Z axis), lie-down position (X, Y axis). The worst emission was found in stand-up position (Z axis) and the worst case was recorded.

In order to find the worst case condition, Pre-tests are needed at the presence of different data rate. Preliminary tests have been done on all the configuration for confirming worst case. Data rate below means worst-case rate of each test item.

Worst-case data rates are shown as following table.

Mode	Data Rate
802.11a	6 Mbps
802.11n HT20	MCS0
802.11n HT40	MCS0
802.11ac VHT20	MCS0
802.11ac VHT40	MCS0
802.11ac VHT80	MCS0

**Wireless Technology and Frequency Range**

Wireless Technology		Bandwidth	Channel	Frequency	
Wi-Fi	U-NII-1	20 MHz	36	5180MHz	
			40	5200MHz	
			44	5220MHz	
			48	5240MHz	
		40 MHz	38	5190MHz	
			46	5230MHz	
	U-NII-3	80 MHz	42	5210MHz	
			20 MHz	149	5745MHz
				153	5765MHz
		157		5785MHz	
		161		5805MHz	
		165		5825MHz	
		40 MHz	151	5755MHz	
			159	5795MHz	
80 MHz	155	5775MHz			

Does this device support TPC Function? Yes No

5. Test Case Results

5.1. Occupied Bandwidth

Ambient condition

Temperature	Relative humidity	Pressure
23°C ~25°C	45%~50%	101.5kPa

Method of Measurement

The EUT was connected to the spectrum analyzer through an external attenuator (20dB) and a known loss cable.

For U-NII-1/U-NII-2A/U-NII-2C, set RBW \approx 1% OCB kHz, VBW \geq 3 \times RBW, measure the maximum width of the emission that is constrained by the frequencies associated with the two outermost amplitude points (upper and lower frequencies) that are attenuated by 26 dB relative to the maximum level measured in the fundamental emission.

For U-NII-3, Set RBW = 100 kHz, VBW \geq 3 \times RBW, measure the maximum width of the emission that is constrained by the frequencies associated with the two outermost amplitude points (upper and lower frequencies) that are attenuated by 6 dB relative to the maximum level measured in the fundamental emission.

Note: The automatic bandwidth measurement capability of a spectrum analyzer or EMI receiver may be employed if it implements the functionality described above.

Use the 99 % power bandwidth function of the instrument

Test Setup

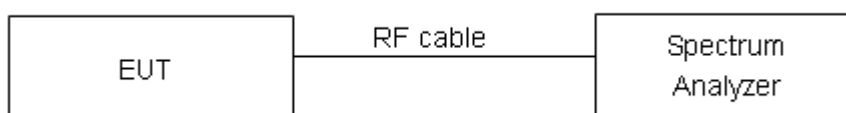

Limits

Rule FCC Part §15.407(e)

Within the 5.725-5.85 GHz band, the minimum 6 dB bandwidth of U-NII devices shall be at least 500 kHz.

Measurement Uncertainty

The assessed measurement uncertainty to ensure 95% confidence level for the normal distribution is with the coverage factor $k = 2$, $U = 936$ Hz.

**Test Results:****U-NII-1**

Mode	Carrier frequency (MHz)	99% bandwidth (MHz)	Minimum 26 dB bandwidth (MHz)	Conclusion
802.11a	5180	16.385	19.62	PASS
	5200	16.415	19.75	PASS
	5240	16.382	20.03	PASS
802.11n HT20	5180	17.552	20.10	PASS
	5200	17.544	20.00	PASS
	5240	17.540	20.20	PASS
802.11n HT40	5190	35.994	40.21	PASS
	5230	35.957	40.00	PASS
802.11ac VHT20	5180	17.507	19.90	PASS
	5200	17.563	19.87	PASS
	5240	17.538	20.45	PASS
802.11ac VHT40	5190	35.961	40.88	PASS
	5230	35.940	40.07	PASS
802.11ac VHT80	5210	75.231	80.31	PASS

U-NII-3

Mode	Carrier frequency (MHz)	99% bandwidth (MHz)	Minimum 6 dB bandwidth (MHz)	Limit (kHz)	Conclusion
802.11a	5745	16.416	15.06	500	PASS
	5785	16.417	15.03	500	PASS
	5825	16.391	15.05	500	PASS
802.11n HT20	5745	17.535	15.03	500	PASS
	5785	17.561	15.06	500	PASS
	5825	17.531	15.09	500	PASS
802.11n HT40	5755	35.986	35.09	500	PASS
	5795	35.969	32.55	500	PASS
802.11ac VHT20	5745	17.531	13.90	500	PASS
	5785	17.544	13.82	500	PASS
	5825	17.551	14.42	500	PASS
802.11ac VHT40	5755	35.959	35.10	500	PASS
	5795	35.948	33.84	500	PASS
802.11ac VHT80	5775	75.250	75.09	500	PASS



99% bandwidth

U-NII-1, 802.11a
Carrier frequency (MHz): 5180



U-NII-1, 802.11n HT20
Carrier frequency (MHz): 5180



U-NII-1, 802.11a
Carrier frequency (MHz): 5200



U-NII-1, 802.11n HT20
Carrier frequency (MHz): 5200



U-NII-1, 802.11a
Carrier frequency (MHz):5240

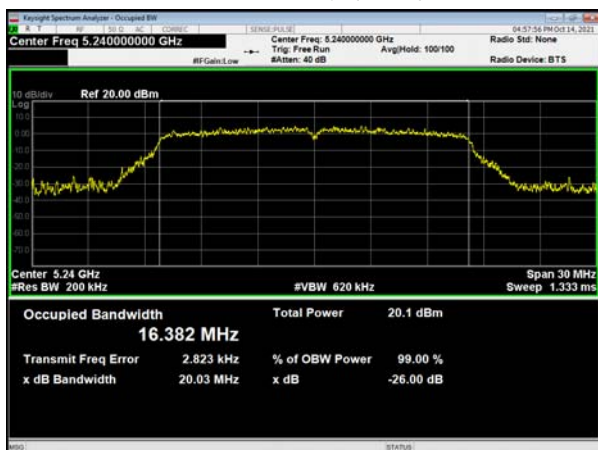

U-NII-1, 802.11n HT20
Carrier frequency (MHz):5240



U-NII-1, 802.11n HT40
Carrier frequency (MHz): 5190

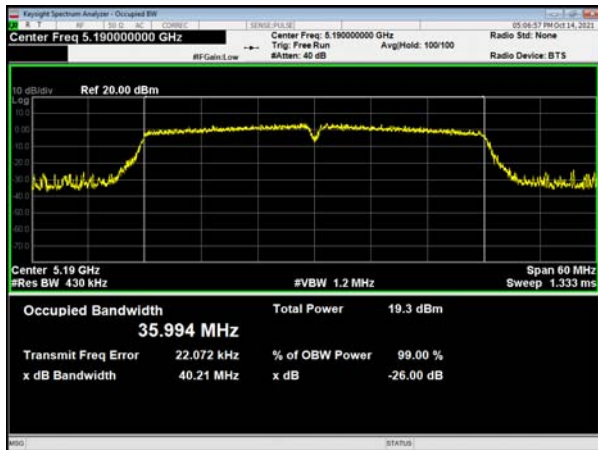

U-NII-1, 802.11ac VHT20
Carrier frequency (MHz): 5180



U-NII-1, 802.11n HT40
Carrier frequency (MHz): 5230



U-NII-1, 802.11ac VHT20
Carrier frequency (MHz): 5200



U-NII-1, 802.11ac VHT40
Carrier frequency (MHz): 5190



U-NII-1, 802.11ac VHT20
Carrier frequency (MHz): 5240





U-NII-1, 802.11ac VHT40
Carrier frequency (MHz): 5230



U-NII-1, 802.11ac VHT80
Carrier frequency (MHz): 5210

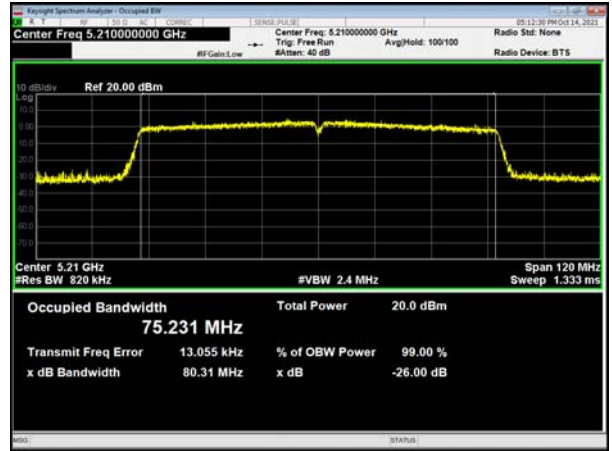

U-NII-3, 802.11a
Carrier frequency (MHz): 5745

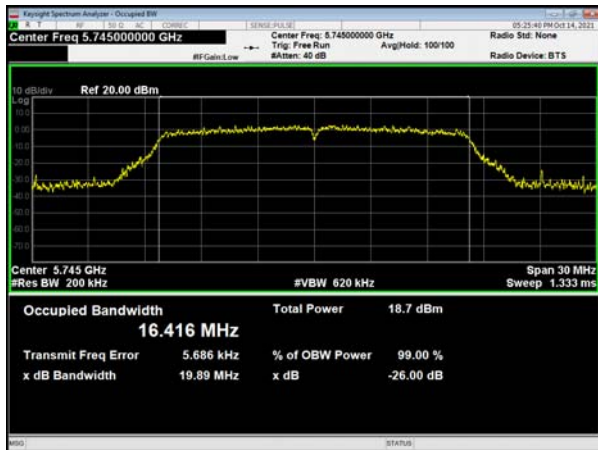

U-NII-3, 802.11n HT20
Carrier frequency (MHz): 5745

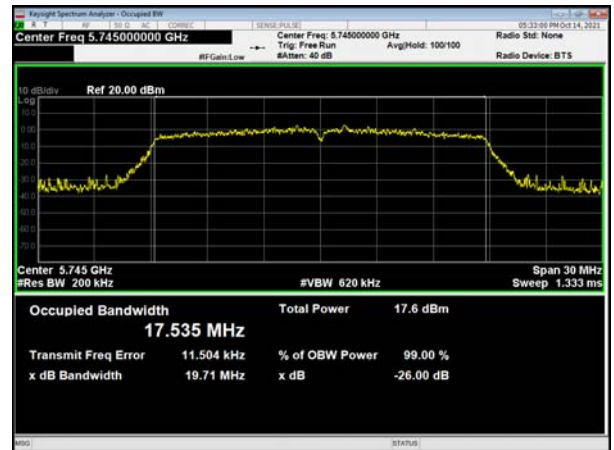

U-NII-3, 802.11a
Carrier frequency (MHz): 5785



U-NII-3, 802.11n HT20
Carrier frequency (MHz): 5785

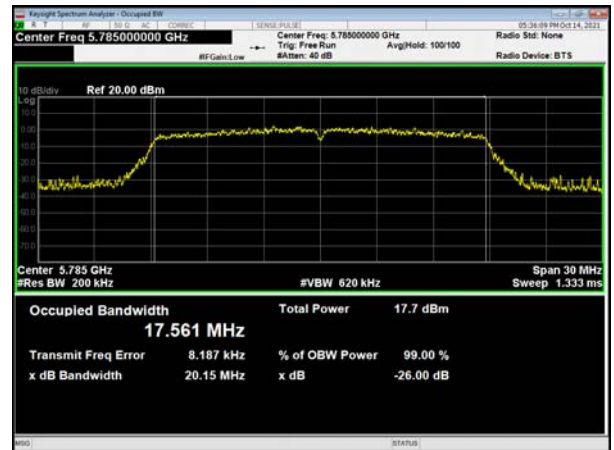

U-NII-3, 802.11a
Carrier frequency (MHz): 5825

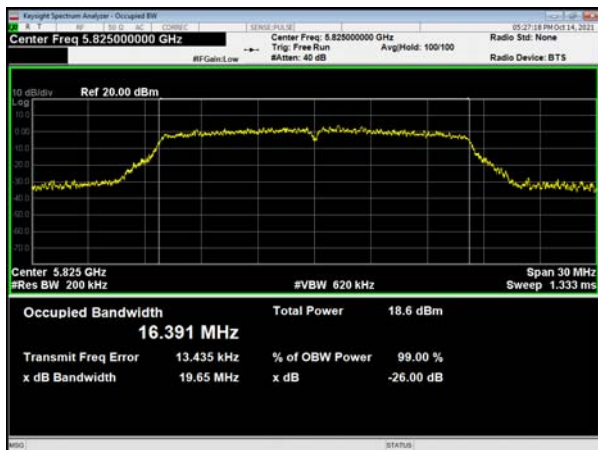

U-NII-3, 802.11n HT20
Carrier frequency (MHz): 5825



U-NII-3, 802.11n HT40
Carrier frequency (MHz): 5755

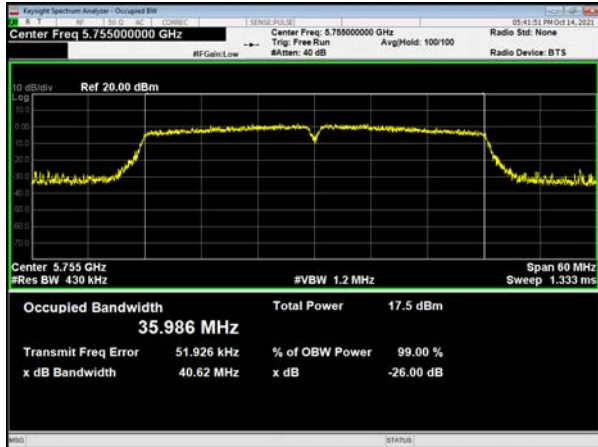

U-NII-3, 802.11ac VHT20
Carrier frequency (MHz): 5745

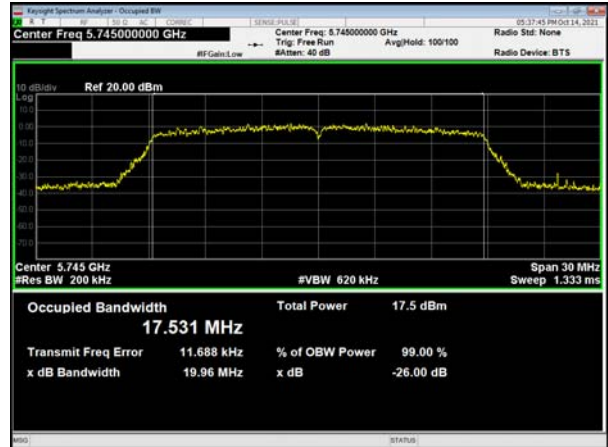

U-NII-3, 802.11n HT40
Carrier frequency (MHz): 5795



U-NII-3, 802.11ac VHT20
Carrier frequency (MHz): 5785



U-NII-3, 802.11ac VHT40
Carrier frequency (MHz): 5755



U-NII-3, 802.11ac VHT20
Carrier frequency (MHz): 5825





U-NII-3, 802.11ac VHT40
Carrier frequency (MHz): 5795

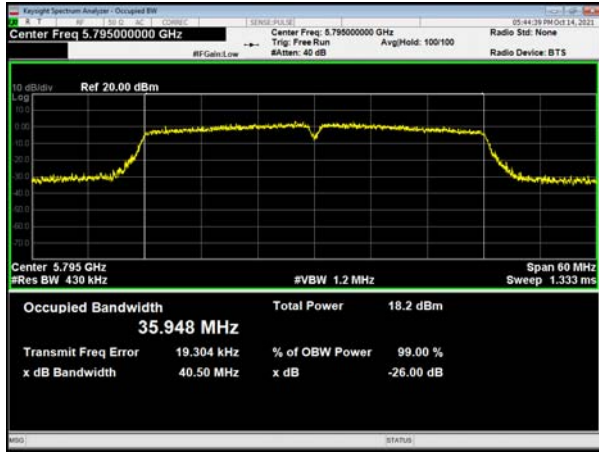

U-NII-3, 802.11ac VHT80
Carrier frequency (MHz): 5775

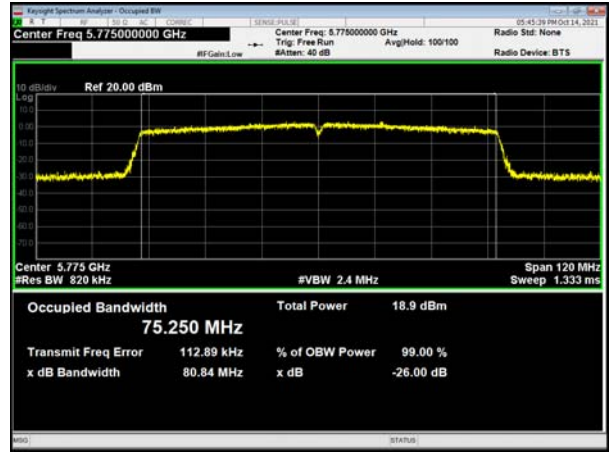

Minimum 6 dB bandwidth

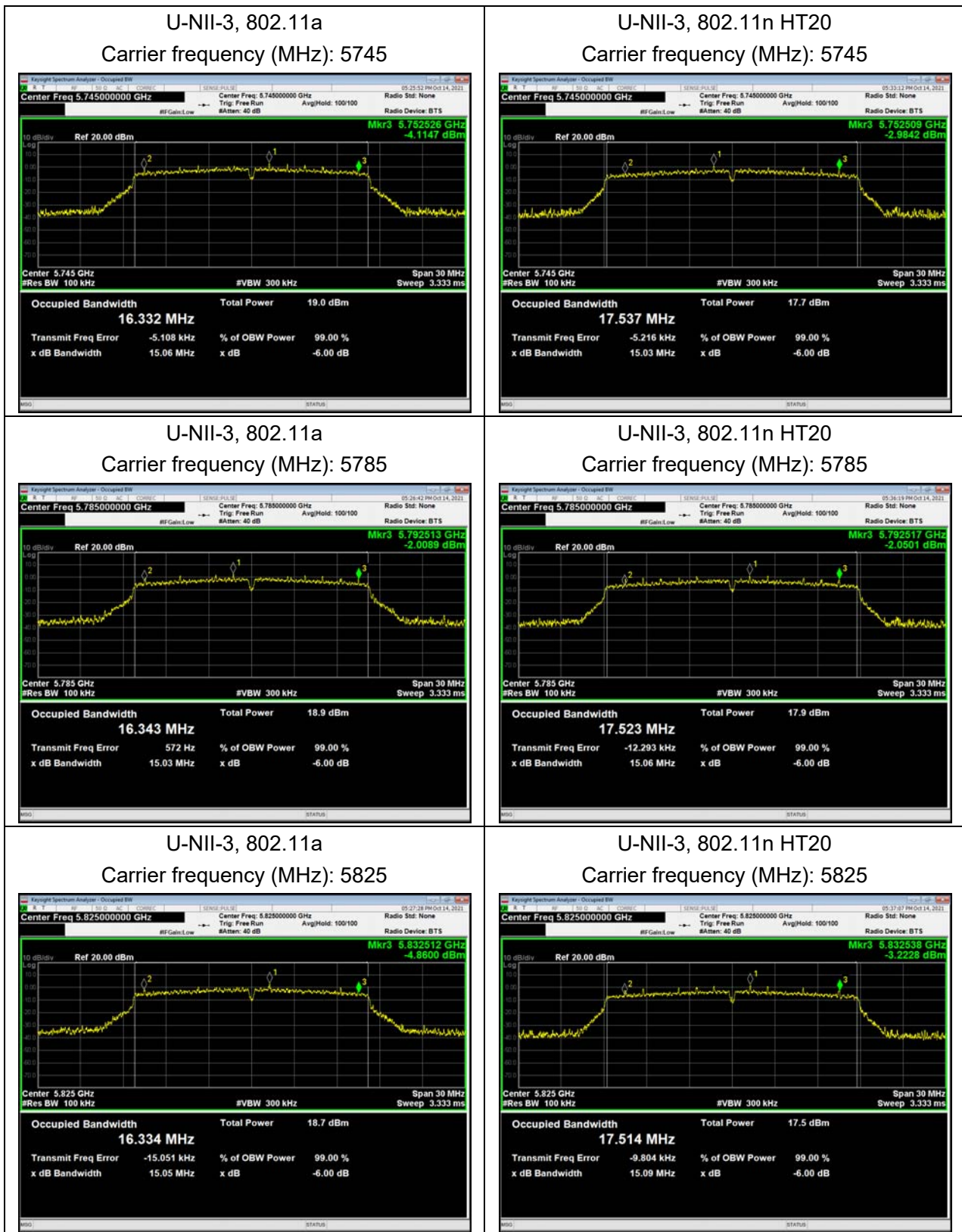

U-NII-3, 802.11n HT40
Carrier frequency (MHz): 5755

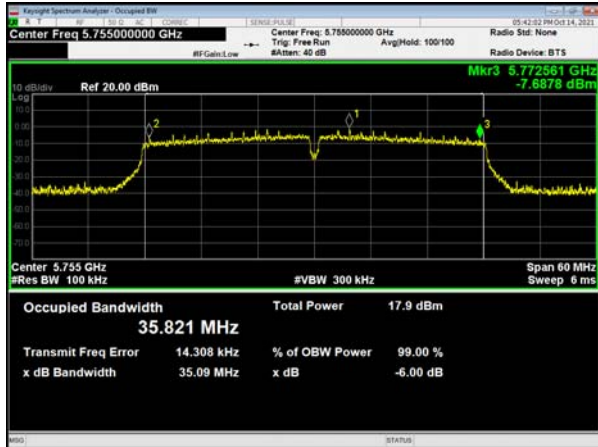

U-NII-3, 802.11ac VHT20
Carrier frequency (MHz): 5745

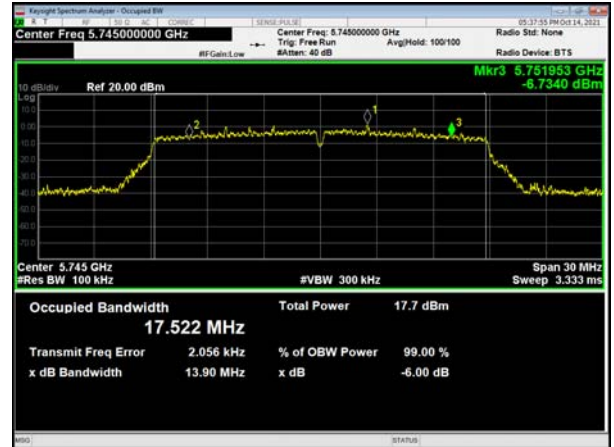

U-NII-3, 802.11n HT40
Carrier frequency (MHz): 5795

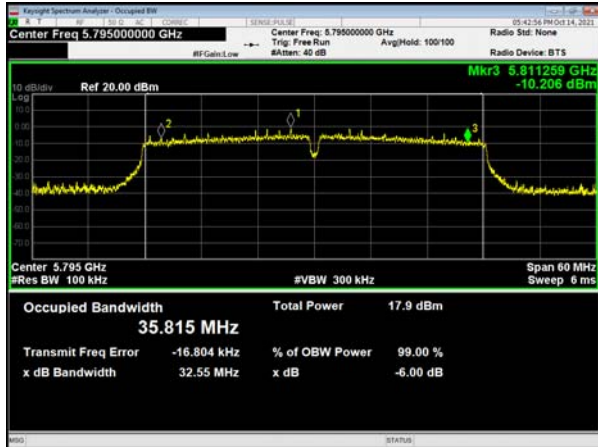

U-NII-3, 802.11ac VHT20
Carrier frequency (MHz): 5785

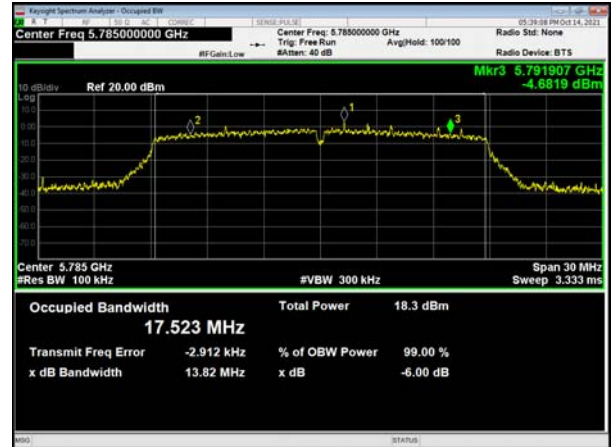

U-NII-3, 802.11ac VHT40
Carrier frequency (MHz): 5755

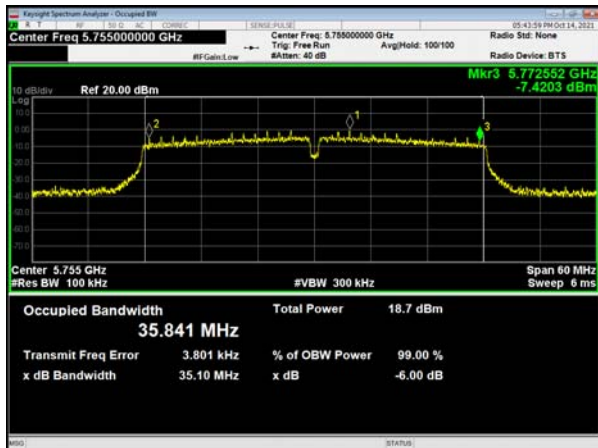

U-NII-3, 802.11ac VHT20
Carrier frequency (MHz): 5825





U-NII-3, 802.11ac VHT40
Carrier frequency (MHz): 5795

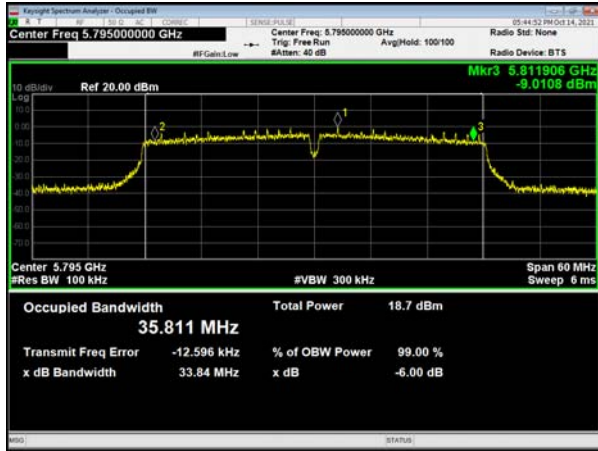

U-NII-3, 802.11ac VHT80
Carrier frequency (MHz): 5775

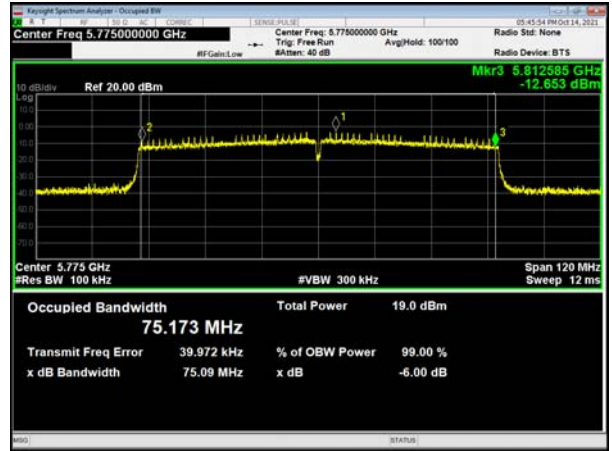

5.2. Average Power Output

Ambient condition

Temperature	Relative humidity	Pressure
23°C ~25°C	45%~50%	101.5kPa

Methods of Measurement

During the process of the testing, The EUT was connected to the average power meter through an external attenuator and a known loss cable. The EUT is max power transmission with proper modulation. We use Maximum average Conducted Output Power Level Method in KDB789033 for this test

Test Setup

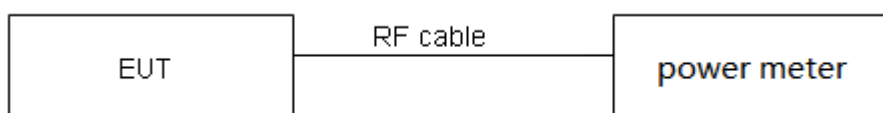

Limits

Rule FCC Part 15.407(a)(1)(2)(3)

(1) For the band 5.15-5.25 GHz.

(i) For an outdoor access point operating in the band 5.15-5.25 GHz, the maximum conducted output power over the frequency band of operation shall not exceed 1 W provided the maximum antenna gain does not exceed 6 dBi. In addition, the maximum power spectral density shall not exceed 17 dBm in any 1 megahertz band. If transmitting antennas of directional gain greater than 6 dBi are used, both the maximum conducted output power and the maximum power spectral density shall be reduced by the amount in dB that the directional gain of the antenna exceeds 6 dBi. The maximum e.i.r.p. at any elevation angle above 30 degrees as measured from the horizon must not exceed 125 mW (21 dBm).

(ii) For an indoor access point operating in the band 5.15-5.25 GHz, the maximum conducted output power over the frequency band of operation shall not exceed 1 W provided the maximum antenna gain does not exceed 6 dBi. In addition, the maximum power spectral density shall not exceed 17 dBm in any 1 megahertz band. If transmitting antennas of directional gain greater than 6 dBi are used, both the maximum conducted output power and the maximum power spectral density shall be reduced by the amount in dB that the directional gain of the antenna exceeds 6 dBi.

(iii) For fixed point-to-point access points operating in the band 5.15-5.25 GHz, the maximum conducted output power over the frequency band of operation shall not exceed 1 W. In addition, the maximum power spectral density shall not exceed 17 dBm in any 1 megahertz band. Fixed point-to-point U-NII devices may employ antennas with directional gain up to 23 dBi without any corresponding reduction in the maximum conducted output power or maximum power spectral density. For fixed point-to-point transmitters that employ a directional antenna gain greater than 23 dBi, a 1 dB reduction in maximum conducted output power and maximum power spectral density is required for each 1 dB of antenna gain in excess of 23 dBi. Fixed, point-to-point operations exclude



the use of point-to-multipoint systems, omnidirectional applications, and multiple collocated transmitters transmitting the same information. The operator of the U-NII device, or if the equipment is professionally installed, the installer, is responsible for ensuring that systems employing high gain directional antennas are used exclusively for fixed, point-to-point operations.

(iv) For client devices in the 5.15-5.25 GHz band, the maximum conducted output power over the frequency band of operation shall not exceed 250 mW provided the maximum antenna gain does not exceed 6 dBi. In addition, the maximum power spectral density shall not exceed 11 dBm in any 1 megahertz band. If transmitting antennas of directional gain greater than 6 dBi are used, both the maximum conducted output power and the maximum power spectral density shall be reduced by the amount in dB that the directional gain of the antenna exceeds 6 dBi.

(2) For the band 5.725-5.85 GHz, the maximum conducted output power over the frequency band of operation shall not exceed 1 W. In addition, the maximum power spectral density shall not exceed 30 dBm in any 500-kHz band. If transmitting antennas of directional gain greater than 6 dBi are used, both the maximum conducted output power and the maximum power spectral density shall be reduced by the amount in dB that the directional gain of the antenna exceeds 6 dBi.

Measurement Uncertainty

The assessed measurement uncertainty to ensure 95% confidence level for the normal distribution is with the coverage factor $k = 2$, $U = 0.44$ dB.

Test Results

Mode	T _{on} (ms)	T _(on+off) (ms)	Duty cycle	Duty cycle correction Factor(dB)
802.11a	1.39	1.43	0.97	0.13
802.11n HT20	1.30	1.34	0.97	0.14
802.11n HT40	0.65	0.69	0.93	0.29
802.11ac VHT20	1.31	1.36	0.96	0.16
802.11ac VHT40	0.65	0.70	0.94	0.28
802.11ac VHT80	0.32	0.37	0.88	0.56

Note: when Duty cycle ≥ 0.98 , Duty cycle correction Factor not required.

Power Index								
Channel	802.11a	802.11n HT20	802.11ac VHT20	Channel	802.11n HT40	802.11ac VHT40	Channel	802.11ac VHT80
CH36	17	16	16	CH38	16	16	CH42	16
CH40	17	16	16	CH46	16	16	/	/
CH48	17	16	16	/	/	/	/	/
CH149	16	15	15	CH151	15	15	CH155	15
CH157	16	15	15	CH159	15	15	/	/
CH165	16	15	15	/	/	/	/	/



Note: Average Power with duty factor = Average Power Measured +Duty cycle correction factor

U-NII-1

Test Mode	Channel/ Frequency (MHz)	Average Power Measured (dBm)	Average Power with duty factor (dBm)	Limit (dBm)	Conclusion
802.11a	36/5180	14.59	14.72	24	PASS
	40/5200	14.63	14.76	24	PASS
	48/5240	14.25	14.38	24	PASS
802.11n HT20	36/5180	13.47	13.61	24	PASS
	40/5200	13.43	13.57	24	PASS
	48/5240	13.13	13.27	24	PASS
802.11n HT40	38/5190	13.46	13.75	24	PASS
	46/5230	13.21	13.50	24	PASS
802.11ac VHT20	36/5180	13.51	13.67	24	PASS
	40/5200	13.50	13.66	24	PASS
	48/5240	13.16	13.32	24	PASS
802.11ac VHT40	38/5190	13.46	13.74	24	PASS
	46/5230	13.21	13.49	24	PASS
802.11ac VHT80	42/5210	13.16	13.72	24	PASS

Note: Average Power with duty factor = Average Power Measured +Duty cycle correction factor



U-NII-3

Test Mode	Channel/ Frequency (MHz)	Average Power Measured (dBm)	Average Power with duty factor (dBm)	Limit (dBm)	Conclusion
802.11a	149/5745	13.25	13.38	30	PASS
	157/5785	13.03	13.16	30	PASS
	165/5825	12.84	12.97	30	PASS
802.11n HT20	149/5745	11.96	12.10	30	PASS
	157/5785	11.89	12.03	30	PASS
	165/5825	11.67	11.81	30	PASS
802.11n HT40	151/5755	12.38	12.67	30	PASS
	159/5795	12.23	12.52	30	PASS
802.11ac VHT20	149/5745	12.09	12.25	30	PASS
	157/5785	12.33	12.49	30	PASS
	165/5825	12.16	12.32	30	PASS
802.11ac VHT40	151/5755	12.41	12.69	30	PASS
	159/5795	12.37	12.65	30	PASS
802.11ac VHT80	155/5775	12.28	12.84	30	PASS

Note: Average Power with duty factor = Average Power Measured +Duty cycle correction factor

5.3. Frequency Stability

Ambient condition

Temperature	Relative humidity	Pressure
23°C ~25°C	45%~50%	101.5kPa

Method of Measurement

1. Frequency stability with respect to ambient temperature

a) Supply the EUT with a nominal ac voltage or install a new or fully charged battery in the EUT. If possible, a dummy load shall be connected to the EUT because an antenna near the metallic walls of an environmental test chamber could affect the output frequency of the EUT. If the EUT is equipped with a permanently attached, adjustable-length antenna, then the EUT shall be placed in the center of the chamber with the antenna adjusted to the shortest length possible. Turn ON the EUT and tune it to one of the number of frequencies shown in 5.6.

b) Couple the unlicensed wireless device output to the measuring instrument by connecting an antenna to the measuring instrument with a suitable length of coaxial cable and placing the measuring antenna near the EUT (e.g., 15 cm away), or by connecting a dummy load to the measuring instrument, through an attenuator if necessary.

c) Adjust the location of the measurement antenna and the controls on the measurement instrument to obtain a suitable signal level (i.e., a level that will not overload the measurement instrument but is strong enough to allow measurement of the operating or fundamental frequency of the EUT).

d) Turn the EUT OFF and place it inside the environmental temperature chamber. For devices that have oscillator heaters, energize only the heater circuit.

e) Set the temperature control on the chamber to the highest specified in the regulatory requirements for the type of device and allow the oscillator heater and the chamber temperature to stabilize.

f) While maintaining a constant temperature inside the environmental chamber, turn the EUT ON and record the operating frequency at startup, and at 2 minutes, 5 minutes, and 10 minutes after the EUT is energized. Four measurements in total are made.

g) Measure the frequency at each of frequencies specified in 5.6.

h) Switch OFF the EUT but do not switch OFF the oscillator heater.

i) Lower the chamber temperature by not more than 10°C, and allow the temperature inside the chamber to stabilize.

j) Repeat step f) through step i) down to the lowest specified temperature.

2. Frequency stability when varying supply voltage

Unless otherwise specified, these tests shall be made at ambient room temperature (+15°C to +25 °C). An antenna shall be connected to the antenna output terminals of the EUT if possible. If the EUT is equipped with or uses an adjustable-length antenna, then it shall be fully extended.

a) Supply the EUT with nominal voltage or install a new or fully charged battery in the EUT. Turn ON the EUT and couple its output to a frequency counter or other frequency-measuring instrument.



- b) Tune the EUT to one of the number of frequencies required in 5.6. Adjust the location of the measurement antenna and the controls on the measurement instrument to obtain a suitable signal level (i.e., a level that will not overload the measurement instrument but is strong enough to allow measurement of the operating or fundamental frequency of the EUT).
- c) Measure the frequency at each of the frequencies specified in 5.6.
- d) Repeat the above procedure at 85% and 115% of the nominal supply voltage.

Limit

Manufacturers of U-NII devices are responsible for ensuring frequency stability such that an emission is maintained within the band of operation under all conditions of normal operation as specified in the users manual.

Measurement Uncertainty

The assessed measurement uncertainty to ensure 95% confidence level for the normal distribution is with the coverage factor $k = 2$, $U = 936\text{Hz}$

**Test Results**

Voltage (V)	Temperature (°C)	U-NII-1 Test Results			
		5200MHz			
		1min	2min	5min	10min
3.85	-20	5200.000198	5199.990381	5199.981991	5199.974354
3.85	-10	5200.002533	5199.986823	5199.981458	5199.970548
3.85	0	5199.994564	5199.980751	5199.974561	5199.965501
3.85	10	5199.988895	5199.975121	5199.971182	5199.957241
3.85	20	5199.982409	5199.973174	5199.962721	5199.953987
3.85	30	5199.972894	5199.968434	5199.955495	5199.944391
3.85	40	5199.972741	5199.964081	5199.949143	5199.941021
3.85	50	5199.968476	5199.960354	5199.945428	5199.934433
3.50	20	5199.967395	5199.958766	5199.942578	5199.929641
4.43	20	5199.962663	5199.956467	5199.939568	5199.927115
Max. ΔMHz		-0.037337	-0.043533	-0.060432	-0.072885
PPM		-7.180282	-8.371809	-11.621625	-14.016260

Voltage (V)	Temperature (°C)	U-NII-3 Test Results			
		5785MHz			
		1min	2min	5min	10min
3.85	-20	5784.994221	5784.986327	5784.983198	5784.977719
3.85	-10	5784.987113	5784.978954	5784.982710	5784.973462
3.85	0	5784.985776	5784.973271	5784.973626	5784.965042
3.85	10	5784.985705	5784.964125	5784.972667	5784.959049
3.85	20	5784.978622	5784.955401	5784.971667	5784.951349
3.85	30	5784.973499	5784.950290	5784.967277	5784.944127
3.85	40	5784.970629	5784.942312	5784.966887	5784.939650
3.85	50	5784.962011	5784.938852	5784.963616	5784.931339
3.50	20	5784.953971	5784.936525	5784.957009	5784.924625
4.43	20	5784.947158	5784.931803	5784.951748	5784.916268
Max. ΔMHz		-0.052842	-0.068197	-0.048252	-0.083732
PPM		-9.134379	-11.788526	-8.340934	-14.473974

5.4. Power Spectral Density

Ambient condition

Temperature	Relative humidity	Pressure
23°C ~25°C	45%~50%	101.5kPa

Method of Measurement

The EUT was connected to the spectrum analyzer through an external attenuator (20dB) and a known loss cable.

Set RBW = 1MHz, VBW =3MHz for the band 5.150-5.250GHz.

Set RBW = 470kHz, VBW =1.5MHz for the band 5.725-5.850GHz

The conducted PSD is measured at each antenna port. The measured results at the various antenna ports are then summed mathematically.

Test setup

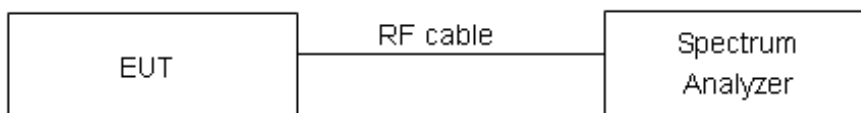

Limits

Rule FCC Part 15.407(a)(1)/ Part 15.407(a)(2) / Part 15.407(a)(3)

For an indoor access point operating in the band 5.15-5.25 GHz, the maximum power spectral density shall not exceed 17 dBm in any 1 megahertz band. If transmitting antennas of directional gain greater than 6 dBi are used, both the maximum conducted output power and the maximum power spectral density shall be reduced by the amount in dB that the directional gain of the antenna exceeds 6 dBi.

For client devices in the 5.15-5.25 GHz band, the maximum conducted output power over the frequency band of operation shall not exceed 250 mW provided the maximum antenna gain does not exceed 6 dBi. In addition, the maximum power spectral density shall not exceed 11 dBm in any 1 megahertz band. If transmitting antennas of directional gain greater than 6 dBi are used, both the maximum conducted output power and the maximum power spectral density shall be reduced by the amount in dB that the directional gain of the antenna exceeds 6 dBi.

For the 5.25-5.35 GHz bands, the maximum power spectral density shall not exceed 11 dBm in any 1 megahertz band. If transmitting antennas of directional gain greater than 6 dBi are used, both the maximum conducted output power and the maximum power spectral density shall be reduced by the amount in dB that the directional gain of the antenna exceeds 6 dBi.

For the band 5.725-5.85 GHz, the maximum power spectral density shall not exceed 30 dBm in any 500kHz band. If transmitting antennas of directional gain greater than 6 dBi are used, both the maximum conducted output power and the maximum power spectral density shall be reduced by the



amount in dB that the directional gain of the antenna exceeds 6 dBi.

Frequency Bands/MHz	Limits
5150-5250	11dBm/MHz
5725-5850	30dBm/500kHz

Measurement Uncertainty

The assessed measurement uncertainty to ensure 95% confidence level for the normal distribution is with the coverage factor $k = 2$, $U = 0.75\text{dB}$.

**Test Results:**

Note: Power Spectral Density =Read Value+Duty cycle correction factor

U-NII-1

Mode	Channel Number	Read Value (dBm /MHz)	Power Spectral Density (dBm /MHz)	Limit (dBm /MHz)	Conclusion
802.11a	36	4.94	5.07	11	PASS
	40	5.32	5.45	11	PASS
	48	4.91	5.04	11	PASS
802.11n HT20	36	4.08	4.22	11	PASS
	40	3.58	3.71	11	PASS
	48	3.26	3.40	11	PASS
802.11n HT40	38	1.06	1.35	11	PASS
	46	0.49	0.78	11	PASS
802.11ac VHT20	36	3.58	3.75	11	PASS
	40	4.07	4.23	11	PASS
	48	3.30	3.47	11	PASS
802.11ac VHT40	38	0.82	1.10	11	PASS
	46	0.46	0.74	11	PASS
802.11ac VHT80	42	-2.38	-1.83	11	PASS



U-NII-3

Mode	Channel Number	Read Value (dBm/470kHz)	Power Spectral Density (dBm/500kHz)	Limit (dBm/500kHz)	Conclusion
802.11a	149	0.16	0.56	30	PASS
	157	0.32	0.72	30	PASS
	165	0.12	0.51	30	PASS
802.11n HT20	149	-1.48	-1.07	30	PASS
	157	-1.35	-0.94	30	PASS
	165	-1.55	-1.14	30	PASS
802.11n HT40	151	-4.29	-3.72	30	PASS
	159	-3.74	-3.17	30	PASS
802.11ac VHT20	149	-1.56	-1.13	30	PASS
	157	-0.56	-0.13	30	PASS
	165	-0.67	-0.23	30	PASS
802.11ac VHT40	151	-3.78	-3.22	30	PASS
	159	-3.29	-2.73	30	PASS
802.11ac VHT80	155	-6.78	-5.95	30	PASS

Note: PSD=Read Value+Duty cycle+10*LOG(500/470) correction factor

U-NII-1, 802.11a, Channel No.: 36

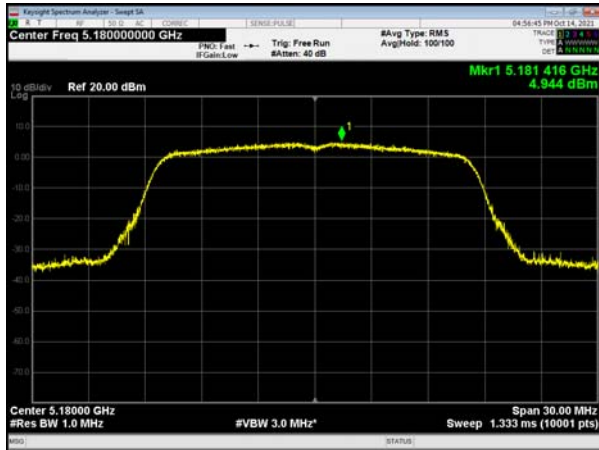

U-NII-1, 802.11n HT20, Channel No.: 36

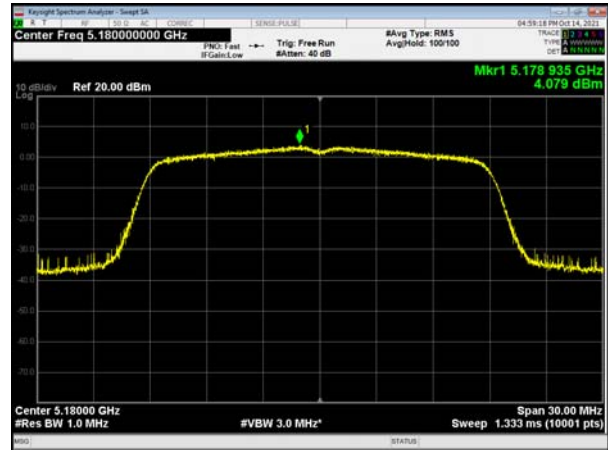

U-NII-1, 802.11a, Channel No.: 40

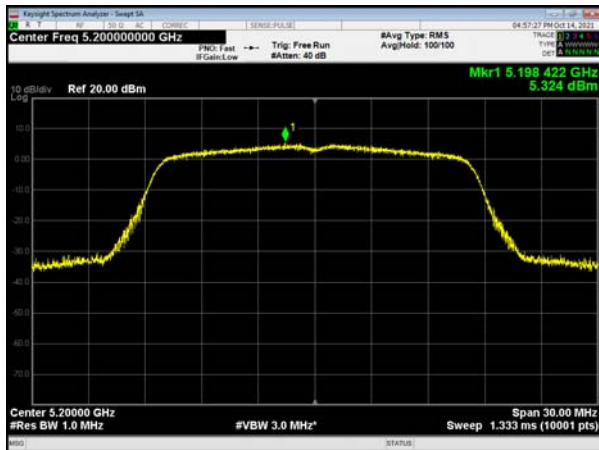

U-NII-1, 802.11n HT20, Channel No.: 40

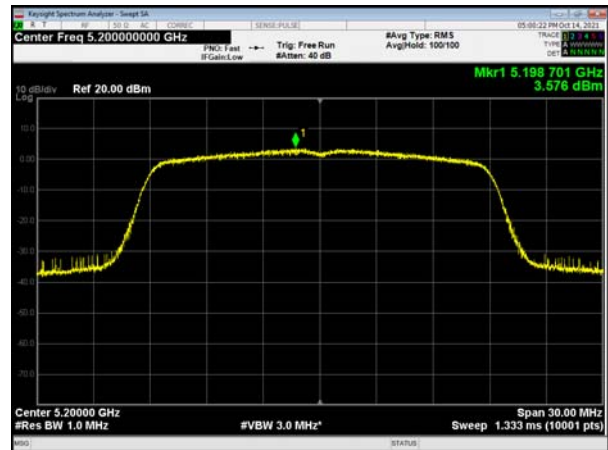

U-NII-1, 802.11a, Channel No.: 48

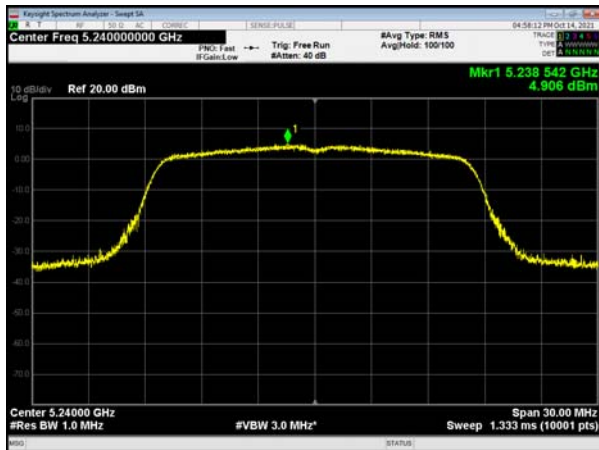

U-NII-1, 802.11n HT20, Channel No.: 48

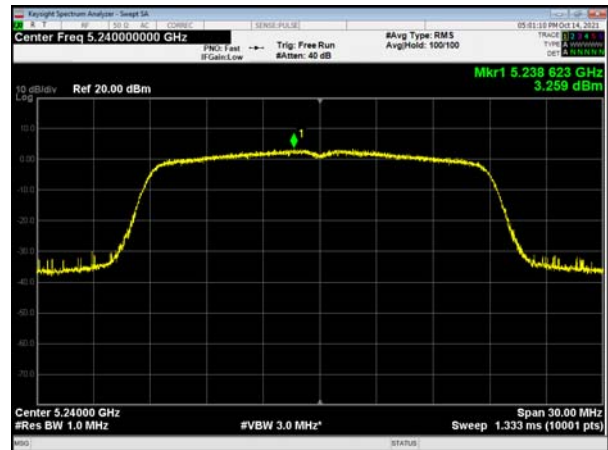

U-NII-1, 802.11n HT40, Channel No.: 38

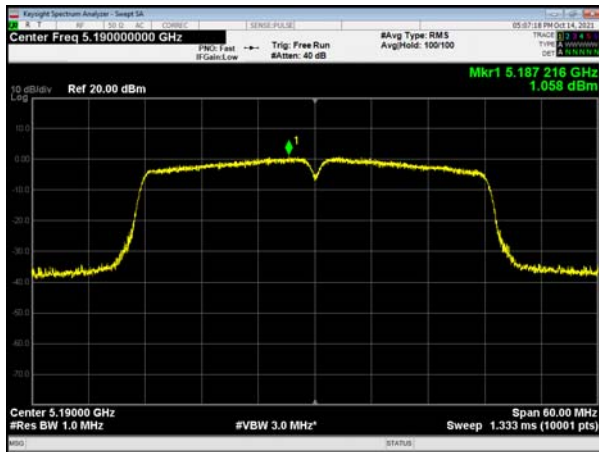

U-NII-1, 802.11ac VHT20, Channel No.: 36

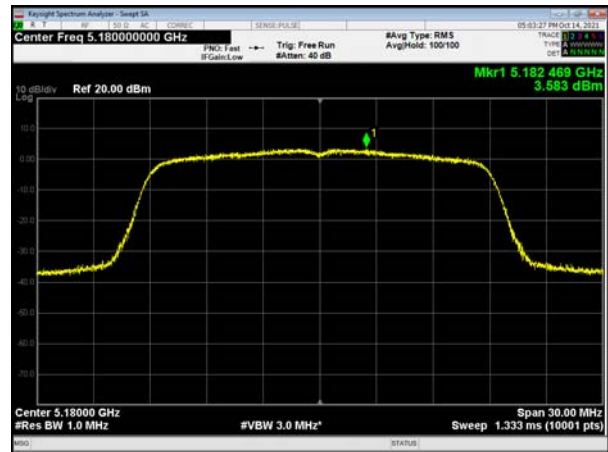

U-NII-1, 802.11n HT40, Channel No.: 46

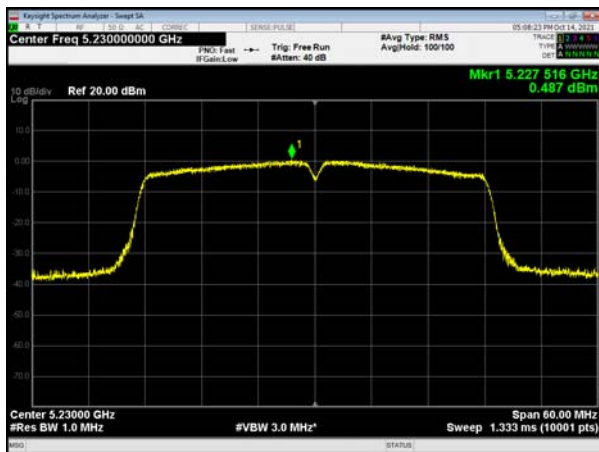

U-NII-1, 802.11ac VHT20, Channel No.: 40

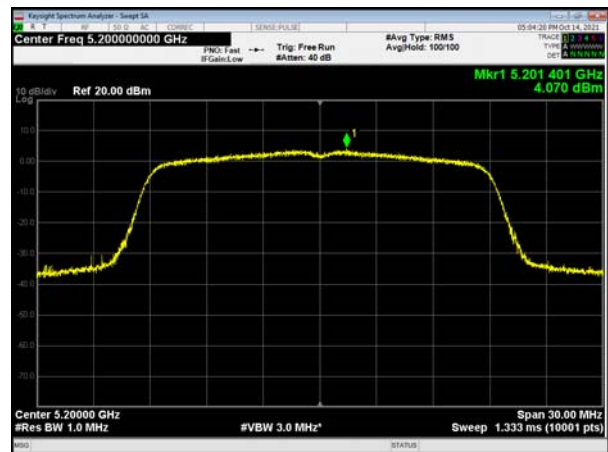

U-NII-1, 802.11ac VHT40, Channel No.: 38

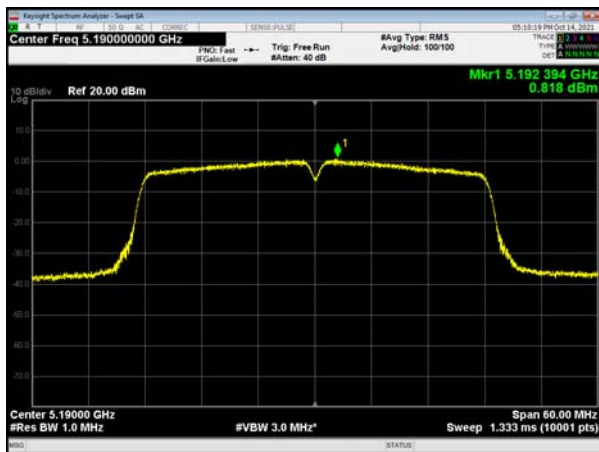

U-NII-1, 802.11ac VHT20, Channel No.: 48

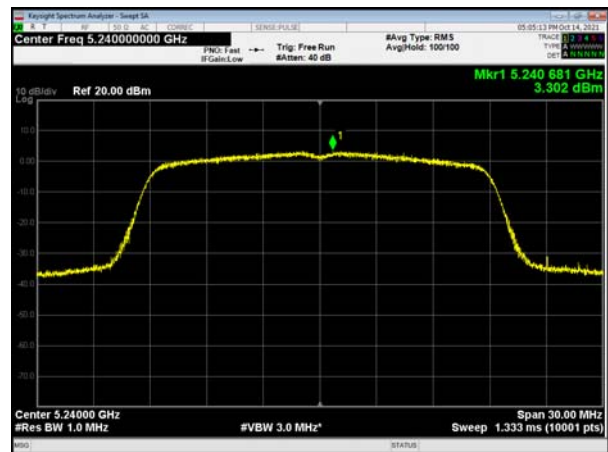

U-NII-1, 802.11ac VHT40, Channel No.: 46

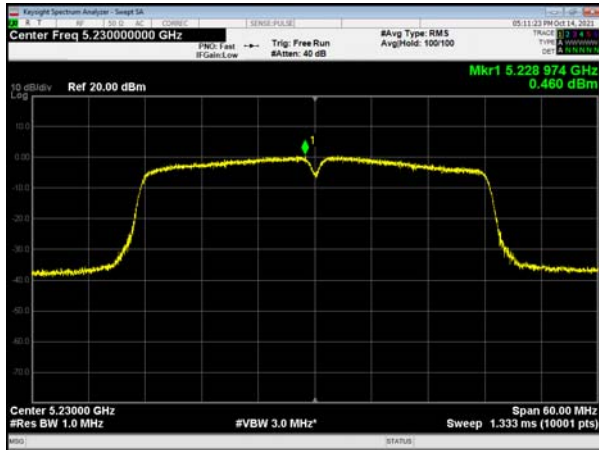

U-NII-1, 802.11ac VHT80, Channel No.: 42

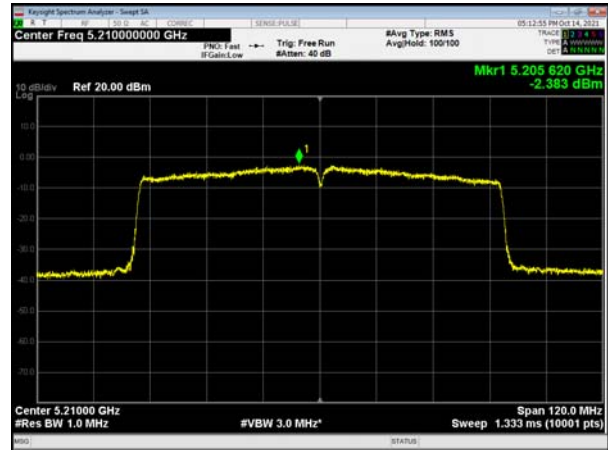

U-NII-3, 802.11a, Channel No.: 149

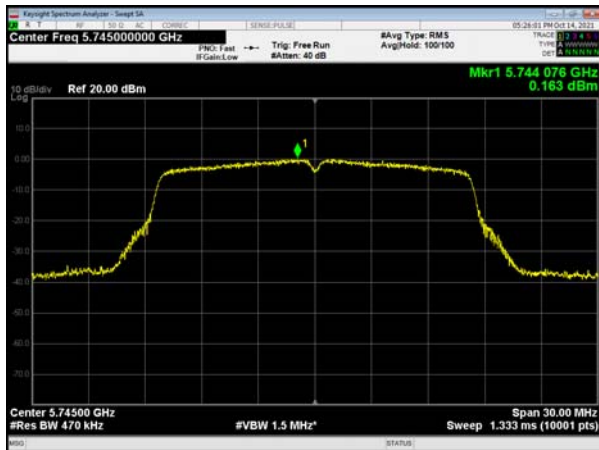

U-NII-3, 802.11n HT20, Channel No.: 149

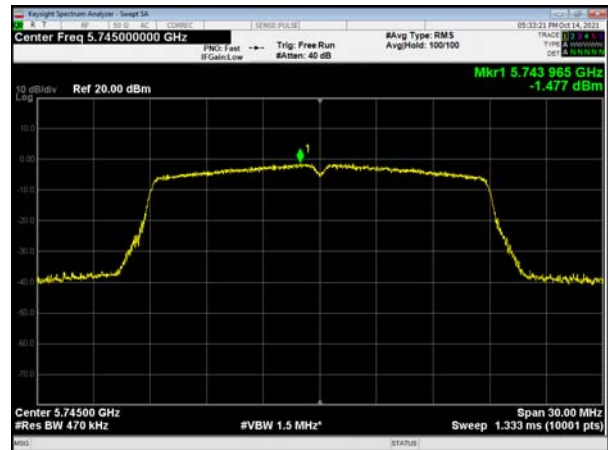

U-NII-3, 802.11a, Channel No.: 157

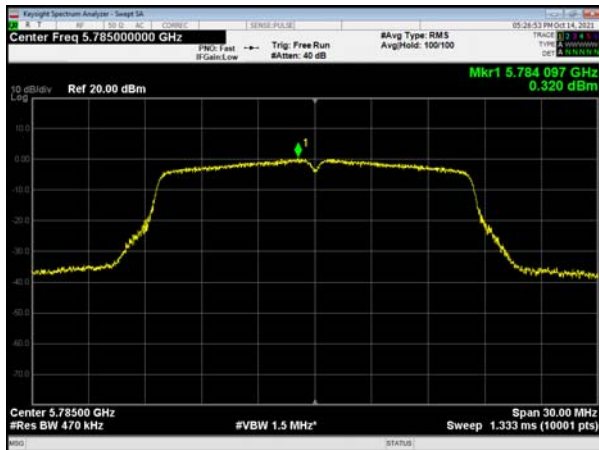

U-NII-3, 802.11n HT20, Channel No.: 157

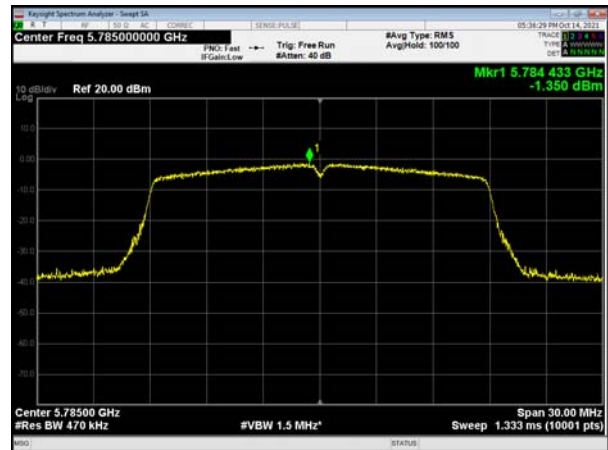



U-NII-3, 802.11a, Channel No.: 165

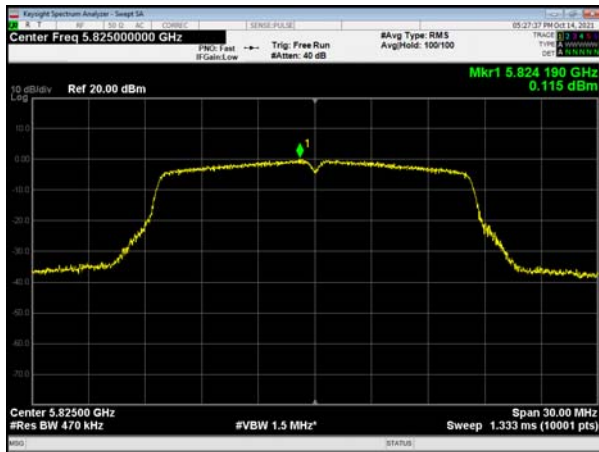

U-NII-3, 802.11n HT20, Channel No.: 165

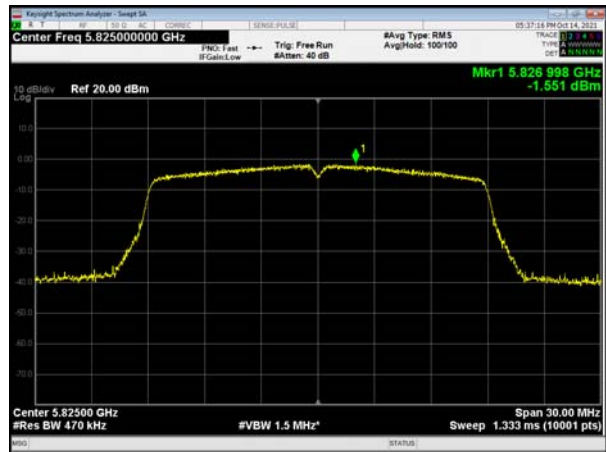

U-NII-3, 802.11n HT40, Channel No.: 151

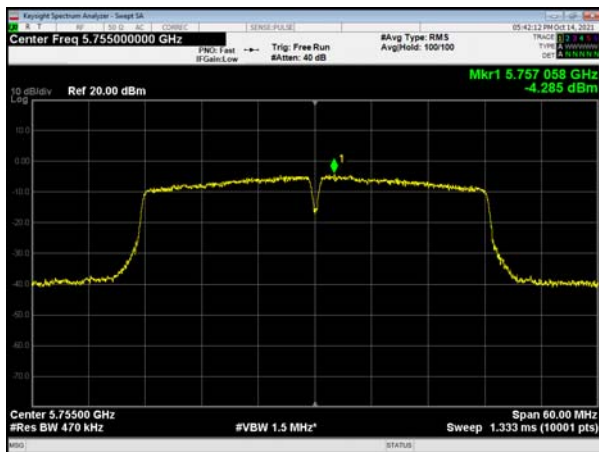

U-NII-3, 802.11ac VHT20, Channel No.: 149

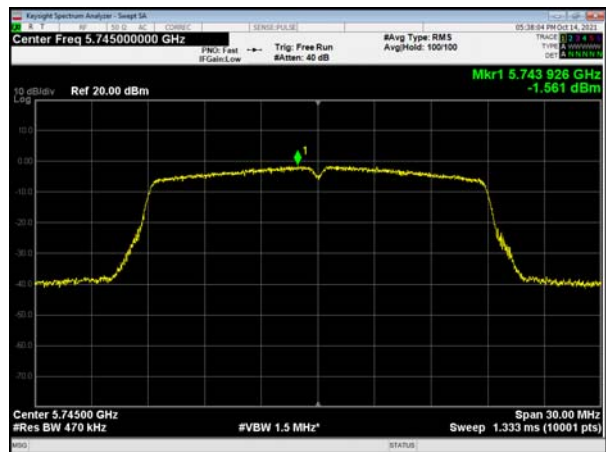

U-NII-3, 802.11n HT40, Channel No.: 159

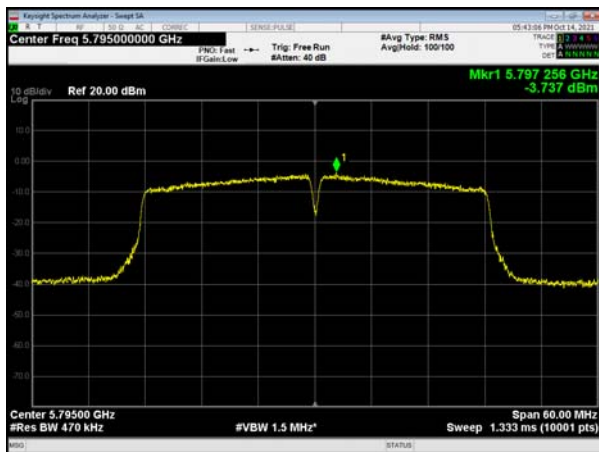

U-NII-3, 802.11ac VHT20, Channel No.: 157

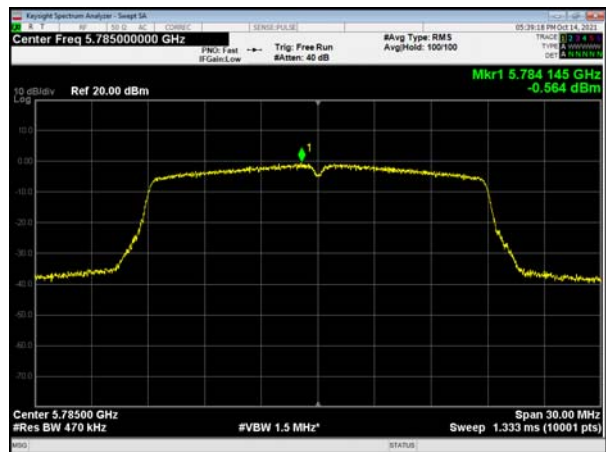

U-NII-3, 802.11ac VHT40, Channel No.: 151

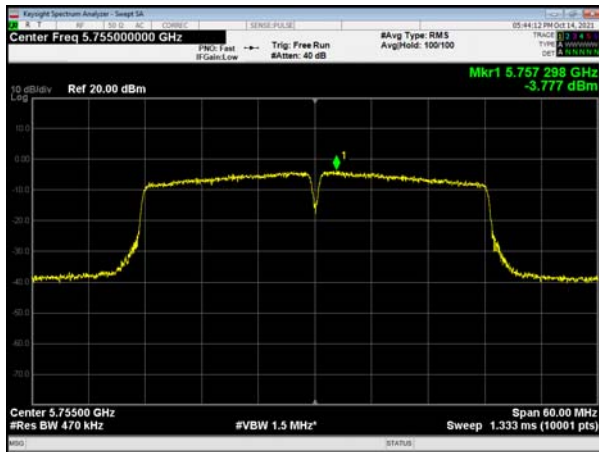

U-NII-3, 802.11ac VHT20, Channel No.: 165

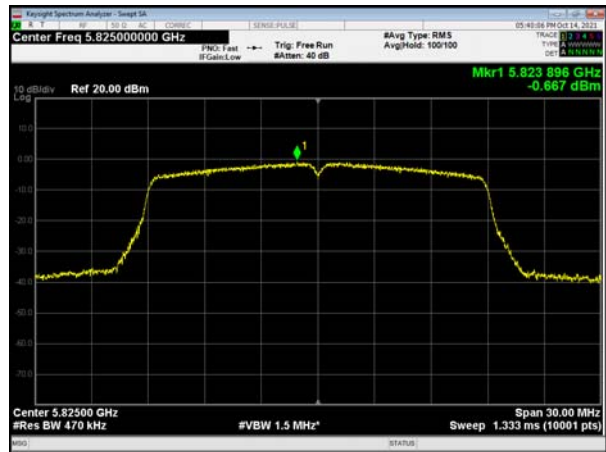

U-NII-3, 802.11ac VHT40, Channel No.: 159

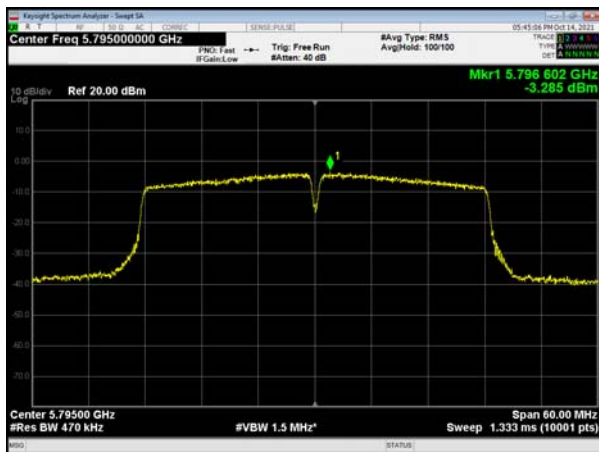

U-NII-3, 802.11ac VHT80, Channel No.: 155

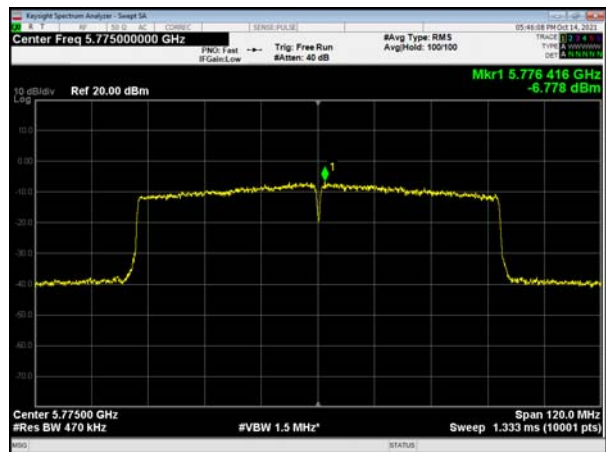

5.5. Unwanted Emission

Ambient condition

Temperature	Relative humidity	Pressure
23°C ~25°C	45%~50%	101.5kPa

Method of Measurement

The test set-up was made in accordance to the general provisions of ANSI C63.10. The Equipment Under Test (EUT) was set up on a non-conductive table in the semi-anechoic chamber. The test was performed at the distance of 3 m between the EUT and the receiving antenna. The radiated emissions measurements were made in a typical installation configuration.

Sweep the whole frequency band range from 9kHz to the 10th harmonic of the carrier, and the emissions less than 20 dB below the permissible value are reported.

During the test, the height of receive antenna shall be moved from 1 to 4 meters, and the antenna shall be performed under horizontal and vertical polarization. The turntable shall be rotated from 0 to 360 degrees for detecting the maximum of radiated spurious signal level. The measurements shall be repeated with orthogonal polarization of the test antenna. The data of cable loss and antenna factor has been calibrated in full testing frequency range before the testing.

Set the spectrum analyzer in the following:

9kHz~150 kHz

RBW=200Hz, VBW=1kHz/ Sweep=AUTO

150 kHz~30MHz

RBW=9KHz, VBW=30KHz,/ Sweep=AUTO

Below 1GHz

RBW=100kHz / VBW=300kHz / Sweep=AUTO

a) Peak emission levels are measured by setting the instrument as follows:

Above 1GHz

PEAK: RBW=1MHz VBW=3MHz/ Sweep=AUTO

b) Average emission levels are measured by setting the instrument as follows:

Above 1GHz

AVERAGE: RBW=1MHz / VBW=3MHz / Sweep=AUTO

c) Detector: The measurements employing a CISPR quasi-peak detector except for the frequency bands 9-90 kHz, 110-490 kHz and above 1000 MHz. Radiated emission limits in these three bands are based on measurements employing an average detector.

d) Averaging type = power (i.e., rms) (As an alternative, the detector and averaging type may be set for linear voltage averaging. Some instruments require linear display mode to use linear voltage averaging. Log or dB averaging shall not be used.)

e) Sweep time = auto.

f) Perform a trace average of at least 100 traces if the transmission is continuous. If the transmission is not continuous, then the number of traces shall be increased by a factor of 1 / D, where D is the duty cycle. For example, with 50% duty cycle, at least 200 traces shall be averaged. (If a specific



emission is demonstrated to be continuous—i.e., 100% duty cycle—then rather than turning ON and OFF with the transmit cycle, at least 100 traces shall be averaged.)

g) If tests are performed with the EUT transmitting at a duty cycle less than 98%, then a correction factor shall be added to the measurement results prior to comparing with the emission limit, to compute the emission level that would have been measured had the test been performed at 100% duty cycle. The correction factor is computed as follows:

1) If power averaging (rms) mode was used in the preceding step e), then the correction factor is $[10 \log (1 / D)]$, where D is the duty cycle. For example, if the transmit duty cycle was 50%, then 3 dB shall be added to the measured emission levels.

2) If linear voltage averaging mode was used in the preceding step e), then the correction factor is $[20 \log (1 / D)]$, where D is the duty cycle. For example, if the transmit duty cycle was 50%, then 6 dB shall be added to the measured emission levels.

3) If a specific emission is demonstrated to be continuous (100% duty cycle) rather than turning ON and OFF with the transmit cycle, then no duty cycle correction is required for that emission.

Reduce the video bandwidth until no significant variations in the displayed signal are observed in subsequent traces, provided the video bandwidth is no less than 1 Hz. For regulatory requirements that specify averaging only over the transmit duration (e.g., digital transmission system [DTS] and Unlicensed National Information Infrastructure [U-NII]), the video bandwidth shall be greater than $[1 / (\text{minimum transmitter on time})]$ and no less than 1 Hz.

The field strength of spurious emission was measured in the following position: EUT stand-up position (Z axis), lie-down position (X, Y axis). The worst emission was found in stand-up position (Z axis) and the loop antenna is vertical, others antenna are vertical and horizontal.

The test is in transmitting mode.

9KHz~~~30MHz

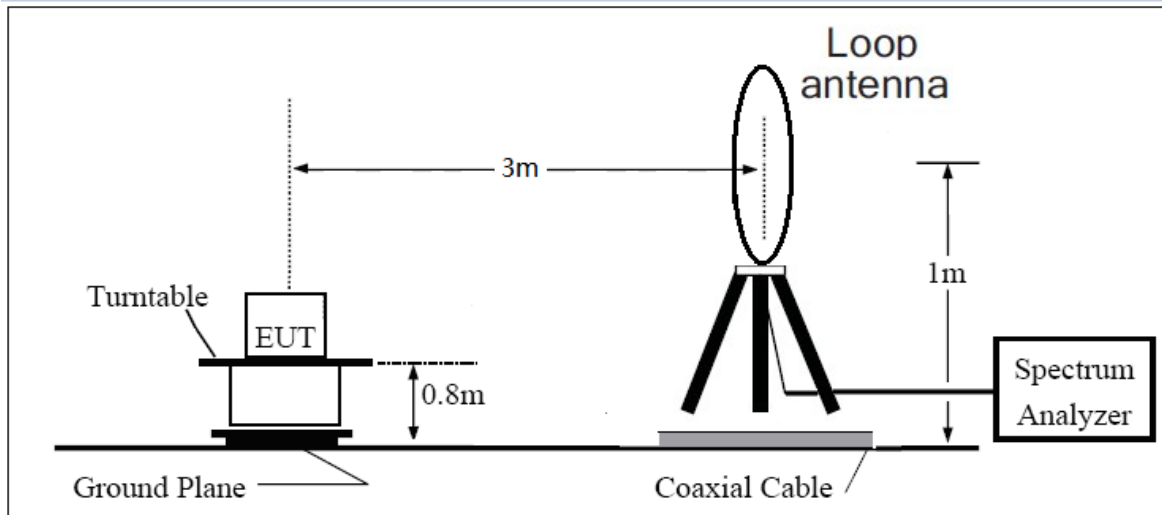

30MHz~~~ 1GHz

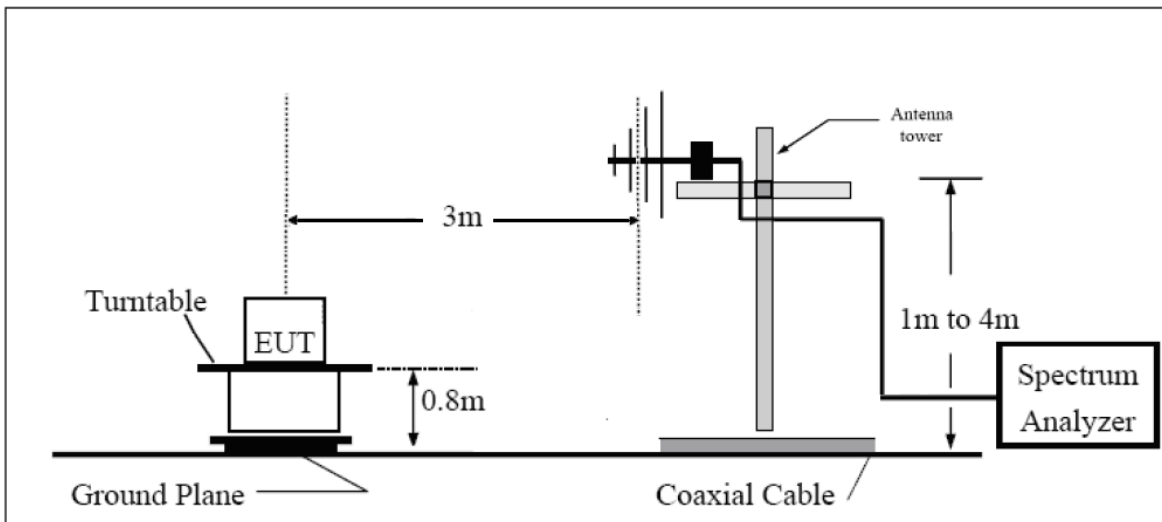

Above 1GHz

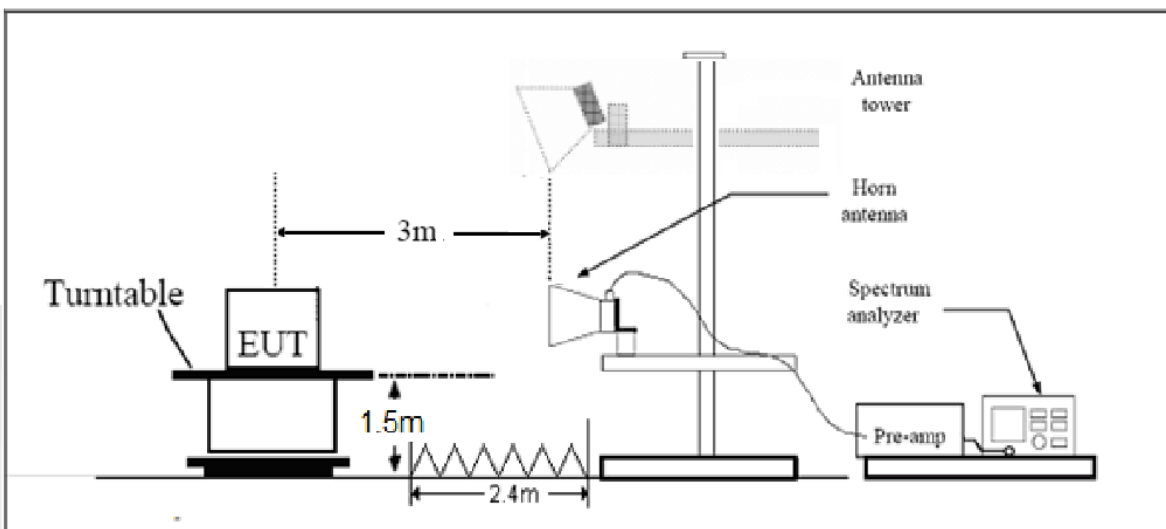

Note: Area side:2.4mX3.6m

Limits

- (1) For transmitters operating in the 5725-5850 MHz band: All emissions shall be limited to a level of -27 dBm/MHz at 75 MHz or more above or below the band edge increasing linearly to 10 dBm/MHz at 25 MHz above or below the band edge, and from 25 MHz above or below the band edge increasing linearly to a level of 15.6 dBm/MHz at 5 MHz above or below the band edge, and from 5 MHz above or below the band edge increasing linearly to a level of 27 dBm/MHz at the band edge.
- (2) For transmitters operating in the 5.15-5.25 GHz band: All emissions outside of the 5.15-5.35 GHz band shall not exceed an e.i.r.p. of -27 dBm/MHz(68.2dBμV/m).
- (3) For transmitters operating in the 5.25-5.35 GHz band: All emissions outside of the 5.15-5.35 GHz band shall not exceed an e.i.r.p. of -27 dBm/MHz(68.2dBμV/m).
- (4) For transmitters operating in the 5.47-5.725 GHz band: All emissions outside of the 5.47-5.725 GHz band shall not exceed an e.i.r.p. of -27 dBm/MHz(68.2dBμV/m).

Note: the following formula is used to convert the EIRP to field strength

§1、 $E[\text{dB}\mu\text{V}/\text{m}] = \text{EIRP}[\text{dBm}] - 20 \log(d[\text{meters}]) + 104.77$, where E = field strength and

d = distance at which field strength limit is specified in the rules;

§2、 $E[\text{dB}\mu\text{V}/\text{m}] = \text{EIRP}[\text{dBm}] + 95.2$, for d = 3 meters

- (5) Unwanted spurious emissions fallen in restricted bands per FCC Part15.205 shall comply with the general field strength limits set forth in § 15.209 as below table.

Frequency of emission (MHz)	Field strength(uV/m)	Field strength(dBuV/m)
0.009–0.490	2400/F(kHz)	/
0.490–1.705	24000/F(kHz)	/
1.705–30.0	30	/
30-88	100	40
88-216	150	43.5
216-960	200	46
Above960	500	54



MHz	MHz	MHz	GHz
0.090 - 0.110	16.42 - 16.423	399.9 - 410	4.5 - 5.15
0.495 - 0.505	16.69475 - 16.69525	608 - 614	5.35 - 5.46
2.1735 - 2.1905	16.80425 - 16.80475	960 - 1240	7.25 - 7.75
4.125 - 4.128	25.5 - 25.67	1300 - 1427	8.025 - 8.5
4.17725 - 4.17775	37.5 - 38.25	1435 - 1626.5	9.0 - 9.2
4.20725 - 4.20775	73 - 74.6	1645.5 - 1646.5	9.3 - 9.5
6.215 - 6.218	74.8 - 75.2	1660 - 1710	10.6 - 12.7
6.26775 - 6.26825	108 - 121.94	1718.8 - 1722.2	13.25 - 13.4
6.31175 - 6.31225	123 - 138	2200 - 2300	14.47 - 14.5
8.291 - 8.294	149.9 - 150.05	2310 - 2390	15.35 - 16.2
8.362 - 8.366	156.52475 - 156.52525	2483.5 - 2500	17.7 - 21.4
8.37625 - 8.38675	156.7 - 156.9	2690 - 2900	22.01 - 23.12
8.41425 - 8.41475	162.0125 - 167.17	3260 - 3267	23.6 - 24.0
12.29 - 12.293	167.72 - 173.2	3332 - 3339	31.2 - 31.8
12.51975 - 12.52025	240 - 285	3345.8 - 3358	36.43 - 36.5
12.57675 - 12.57725	322 - 335.4	3600 - 4400	(²)
13.36 - 13.41			

Measurement Uncertainty

The assessed measurement uncertainty to ensure 95% confidence level for the normal distribution is with the coverage factor $k = 1.96$.

Frequency	Uncertainty
9KHz-30MHz	3.55 dB
30MHz-200MHz	4.17 dB
200MHz-1GHz	4.84 dB
1-18GHz	4.35 dB
18-26.5GHz	5.90 dB
26.5GHz~40GHz	5.92 dB

Test Results:

The modulation and bandwidth are similar for 802.11n mode for 20MHz/40MHz and 802.11ac mode for V20MHz/V40MHz, therefore investigated worst case to representative mode in test report.

The signal beyond the limit is carrier.

U-NII-1

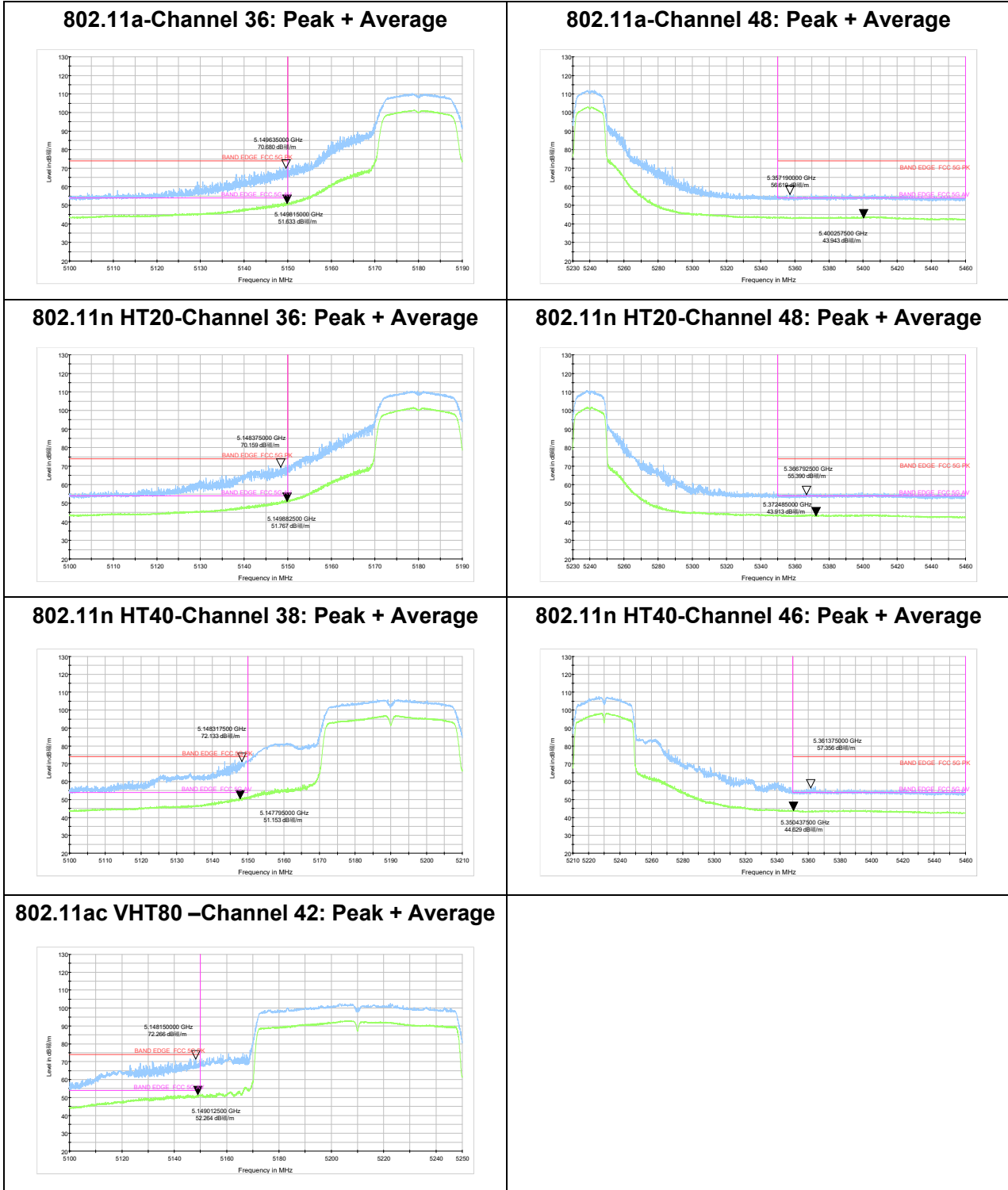



U-NII-3

802.11a-Channel 149: Peak

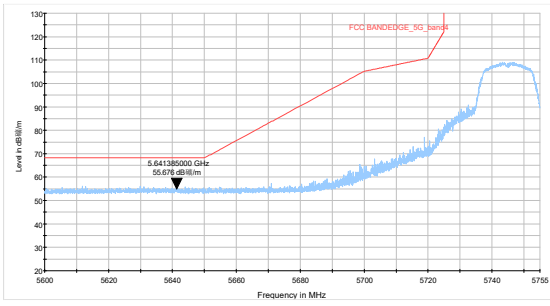

802.11a-Channel 165: Peak

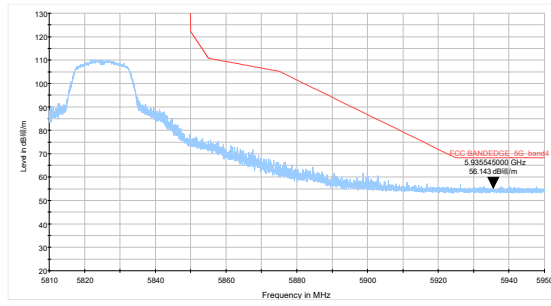

802.11n HT20-Channel 149: Peak

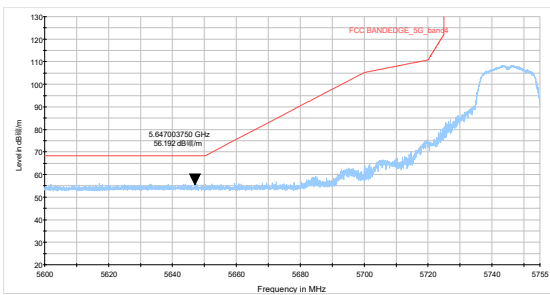

802.11n HT20-Channel 165: Peak

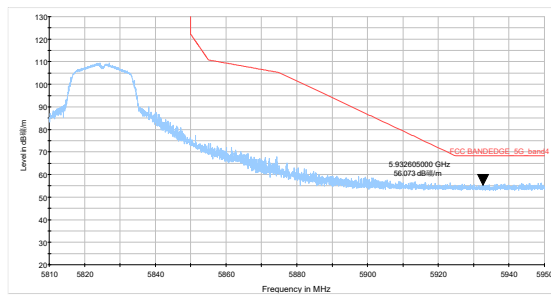

802.11n HT40-Channel 151: Peak

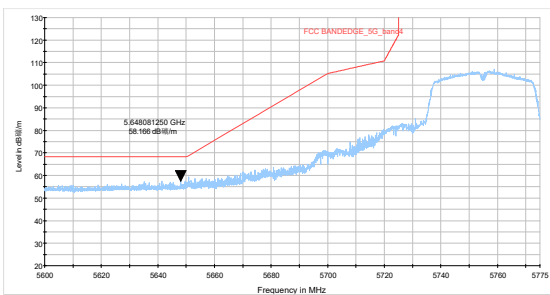

802.11n HT40-Channel 159: Peak

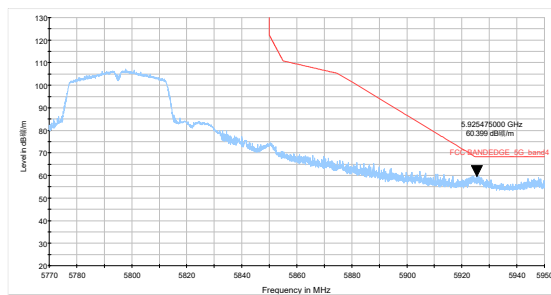

802.11ac VHT80- Channel 155: Peak

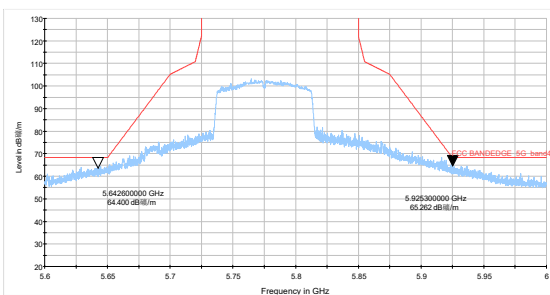



Result of RE

Test result

Sweep the whole frequency band through the range from 9kHz to the 10th harmonic of the carrier, the Emissions in the frequency band 9kHz-30MHz and 26.5GHz-40GHz are more than 20dB below the limit are not reported.

During the test, the Radiates Emission from 30MHz to 1GHz was performed in all modes with all channels, 802.11n(HT 20), Channel 36 are selected as the worst condition. The test data of the worst-case condition was recorded in this report.

Continuous TX mode:

FCC RE 9K-90KHz AV

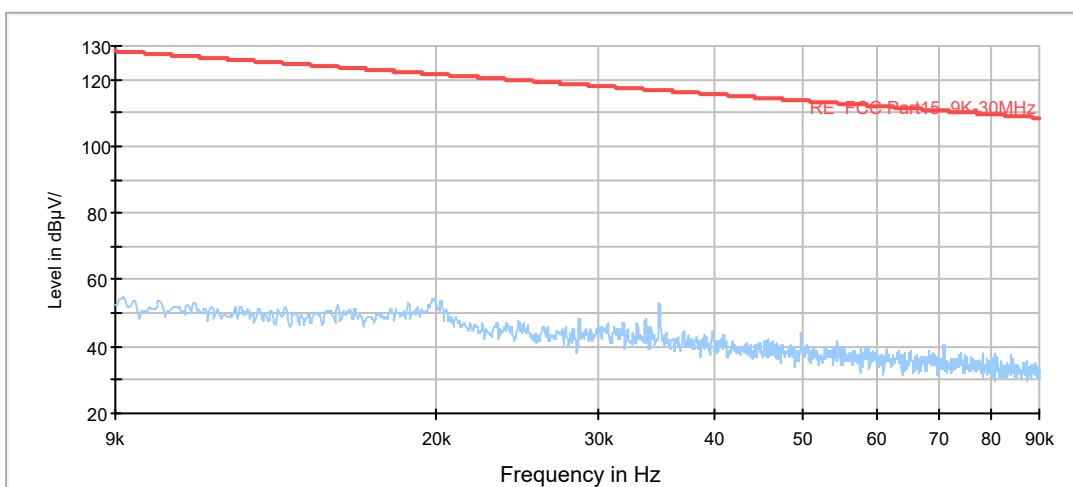

Radiates Emission from 9KHz to 90KHz

FCC RE 90K-110KHz QP

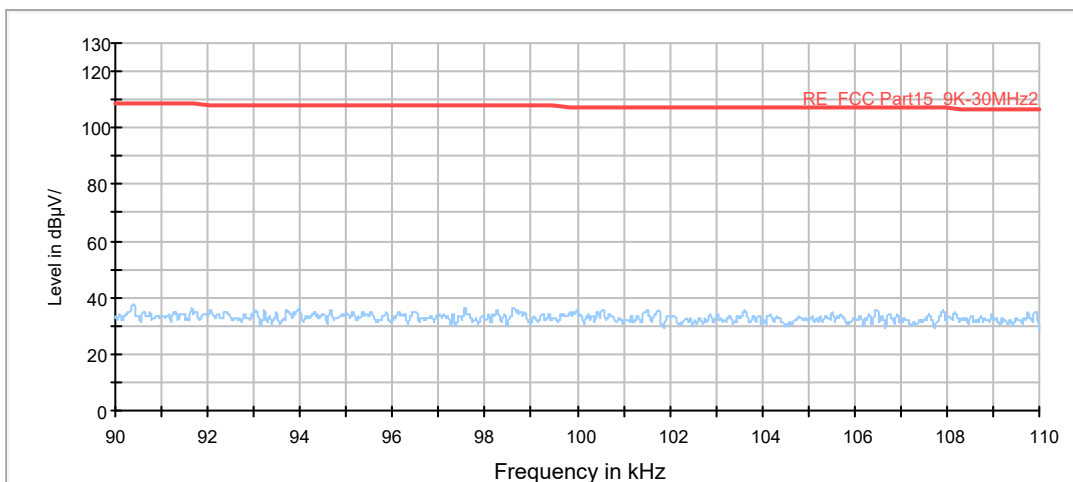

Radiates Emission from 90KHz to 110KHz

FCC RE 110K-490KHz AV

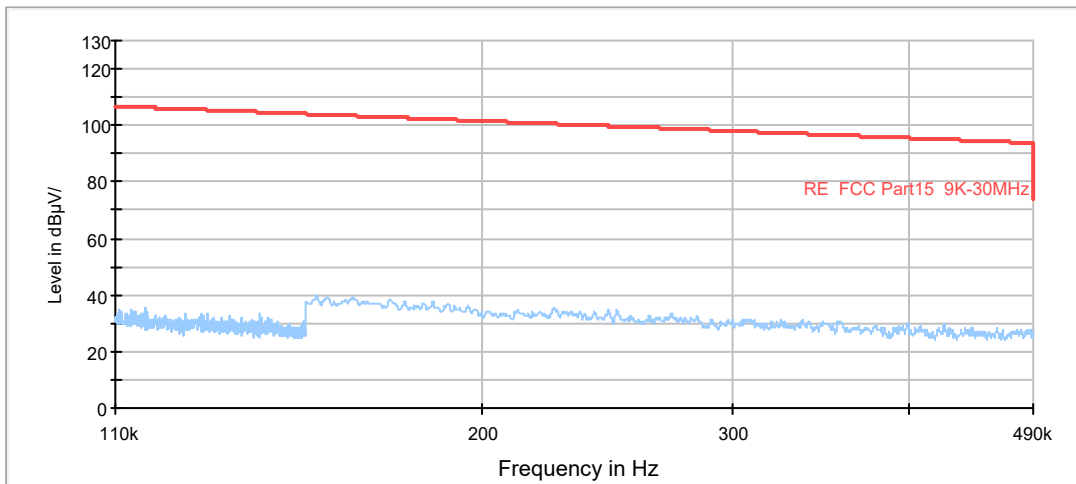

Radiates Emission from 110KHz to 490KHz

FCC RE 490K-30MHz QP

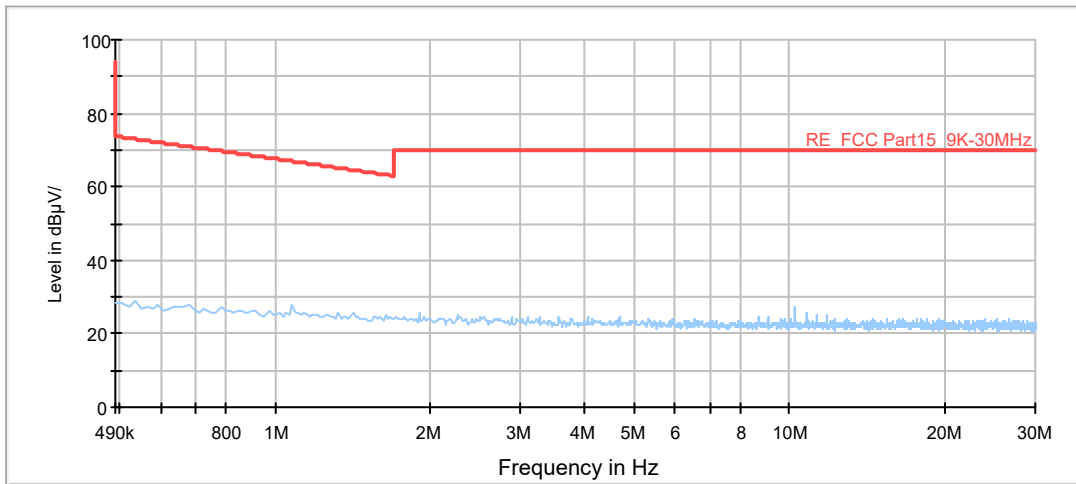

Radiates Emission from 490KHz to 30MHz

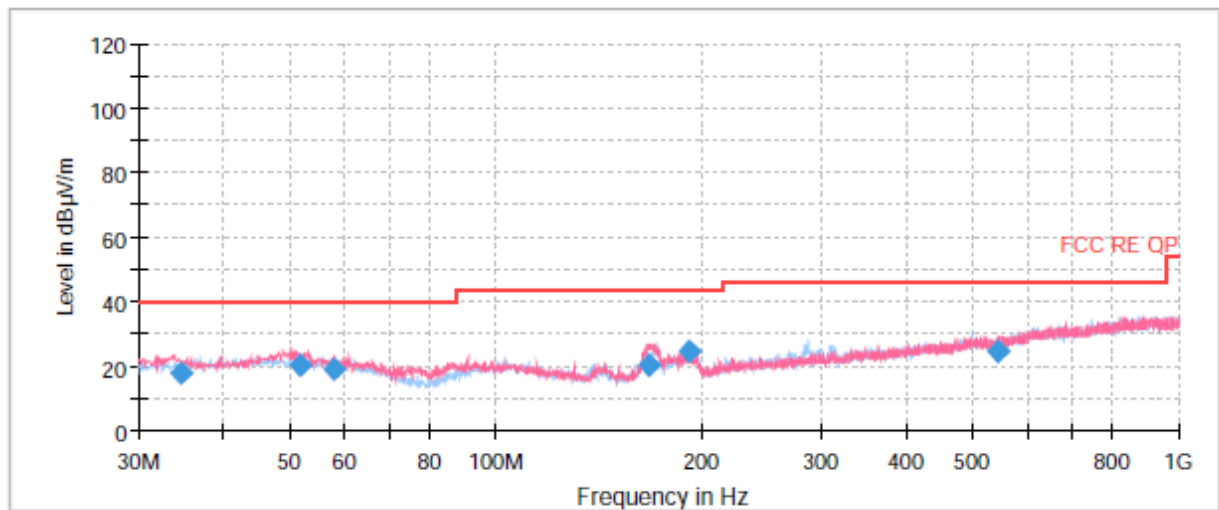

Radiates Emission from 30MHz to 1GHz

Frequency (MHz)	Quasi-Peak (dBuV/m)	Height (cm)	Polarization	Azimuth (deg)	Correct Factor (dB)	Margin (dB)	Limit (dBuV/m)
34.640000	17.70	115.0	V	338.0	13	22.30	40.00
51.612500	20.53	105.0	V	285.0	14	19.47	40.00
57.968750	19.19	175.0	V	210.0	14	20.81	40.00
168.181250	20.03	100.0	V	0.0	10	23.47	43.50
191.516250	24.87	175.0	H	266.0	12	18.63	43.50
543.248750	24.83	213.0	V	290.0	20	21.17	46.00

Remark: 1. Correction Factor = Antenna factor+ Insertion loss(cable loss+amplifier gain)
 2. Margin = Limit – Quasi-Peak

802.11a CH36

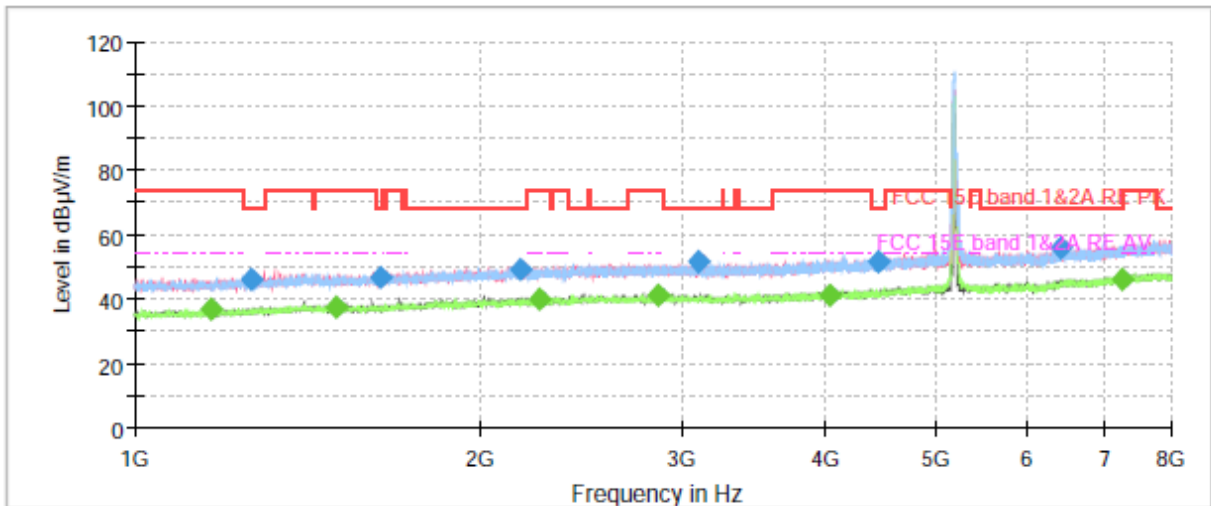

Note: The signal beyond the limit is carrier.
Radiates Emission from 1GHz to 8GHz

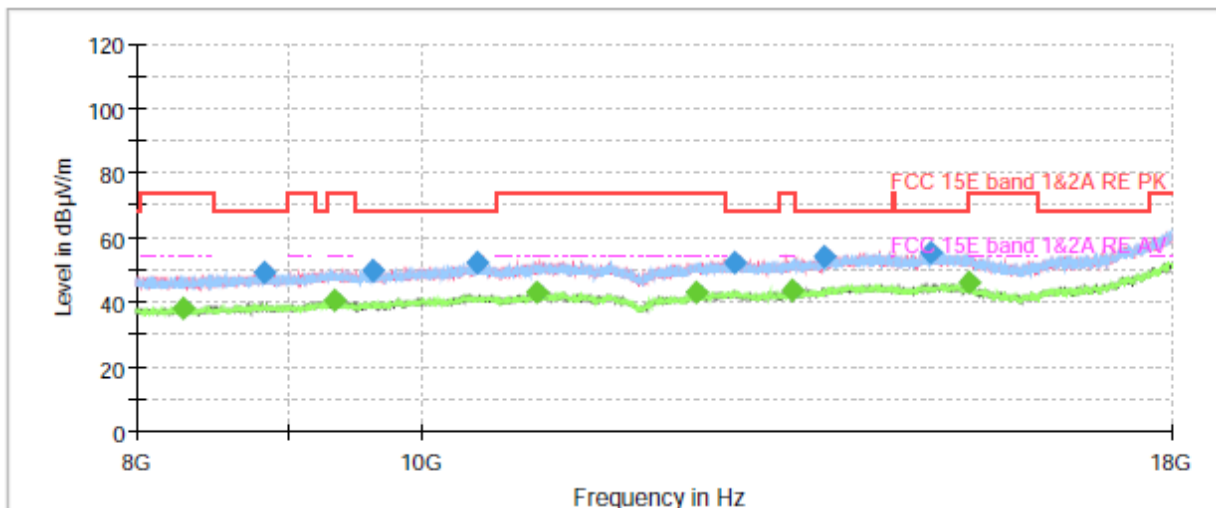

Radiates Emission from 8GHz to 18GHz



Frequency (MHz)	Peak (dBuV/m)	Average (dBuV/m)	Limit (dBuV/m)	Margin (dB)	Height (cm)	Polarization	Azimuth (deg)	Correct Factor (dB)
1164.966667	---	36.72	54.00	17.28	100.0	V	90.0	-9
1265.066667	46.40	---	68.20	21.80	100.0	V	2.0	-8
1500.266667	---	37.43	54.00	16.57	200.0	V	337.0	-7
1634.900000	46.95	---	68.20	21.25	100.0	V	184.0	-6
2164.800000	48.93	---	68.20	19.27	100.0	V	0.0	-4
2251.133333	---	39.79	54.00	14.21	100.0	V	197.0	-4
2853.133333	---	41.14	54.00	12.86	200.0	V	232.0	-3
3103.033333	51.78	---	68.20	16.42	200.0	H	2.0	-3
4035.433333	---	41.51	54.00	12.49	100.0	V	144.0	-1
4453.800000	51.83	---	68.20	16.37	200.0	H	16.0	0
6424.300000	56.28	---	68.20	11.92	100.0	H	357.0	5
7268.500000	---	46.43	54.00	7.57	200.0	V	337.0	6

Remark: 1. Correction Factor = Antenna factor+ Insertion loss (cable loss + amplifier gain)

802.11a CH40

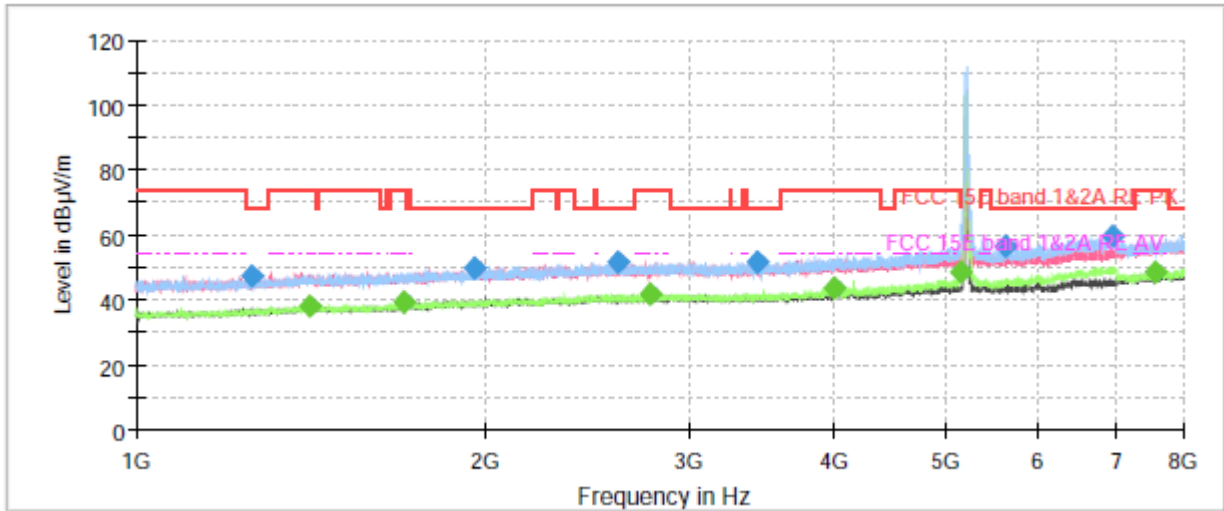

Note: The signal beyond the limit is carrier.
Radiates Emission from 1GHz to 8GHz

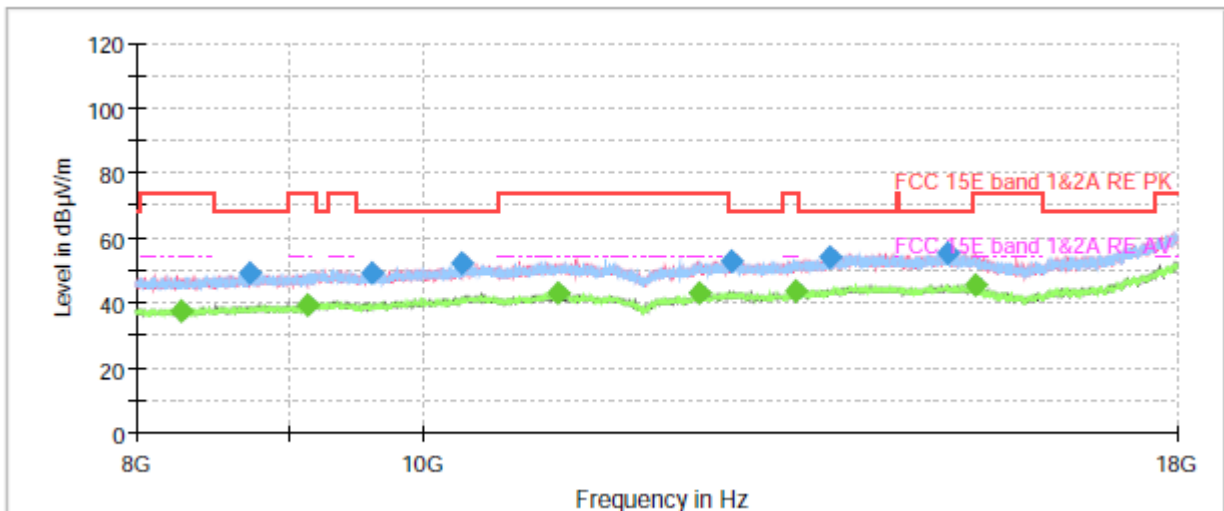

Radiates Emission from 8GHz to 18GHz



Frequency (MHz)	Peak (dBuV/m)	Average (dBuV/m)	Limit (dBuV/m)	Margin (dB)	Height (cm)	Polarization	Azimuth (deg)	Correct Factor (dB)
1258.066667	47.38	---	68.20	20.82	200.0	H	318.0	-8
1411.366667	---	38.44	54.00	15.56	100.0	H	323.0	-7
1702.100000	---	39.12	54.00	14.88	200.0	H	318.0	-6
1956.666667	49.75	---	68.20	18.45	100.0	V	126.0	-5
2608.133333	51.78	---	68.20	16.42	100.0	V	250.0	-4
2776.600000	---	41.81	54.00	12.19	200.0	H	350.0	-4
3437.633333	51.69	---	68.20	16.51	100.0	H	225.0	-3
3996.700000	---	43.55	54.00	10.45	100.0	H	255.0	-1
5149.366667	---	48.80	54.00	5.20	100.0	H	0.0	2
5624.666667	56.78	---	68.20	11.42	100.0	H	0.0	3
6947.666667	59.94	---	68.20	8.26	100.0	H	124.0	7
7562.733333	---	48.64	54.00	5.36	100.0	H	96.0	7

Remark: 1. Correction Factor = Antenna factor+ Insertion loss (cable loss + amplifier gain)

802.11a CH48

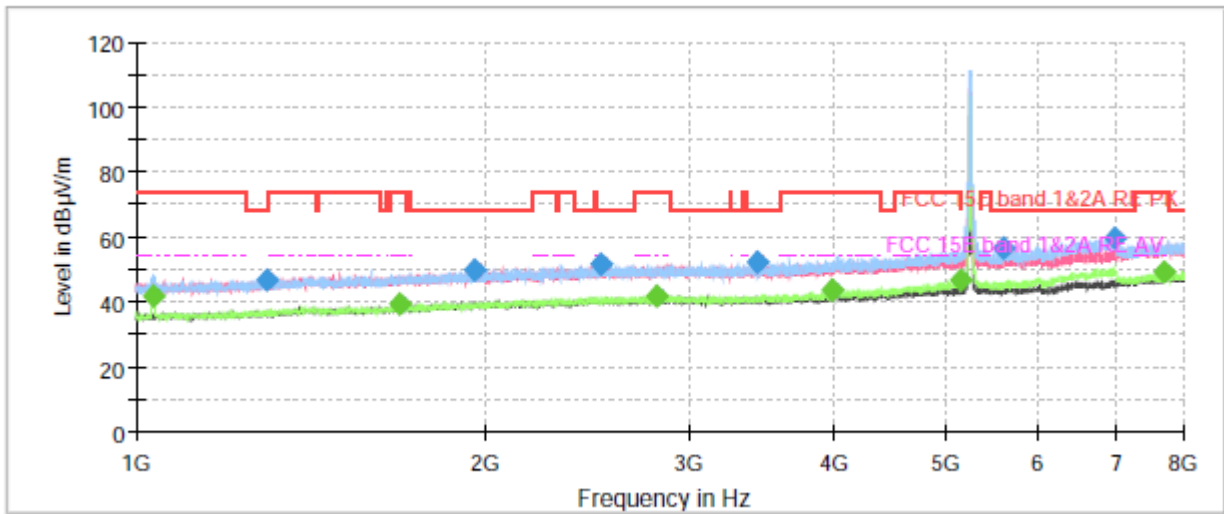

Note: The signal beyond the limit is carrier.
Radiates Emission from 1GHz to 8GHz

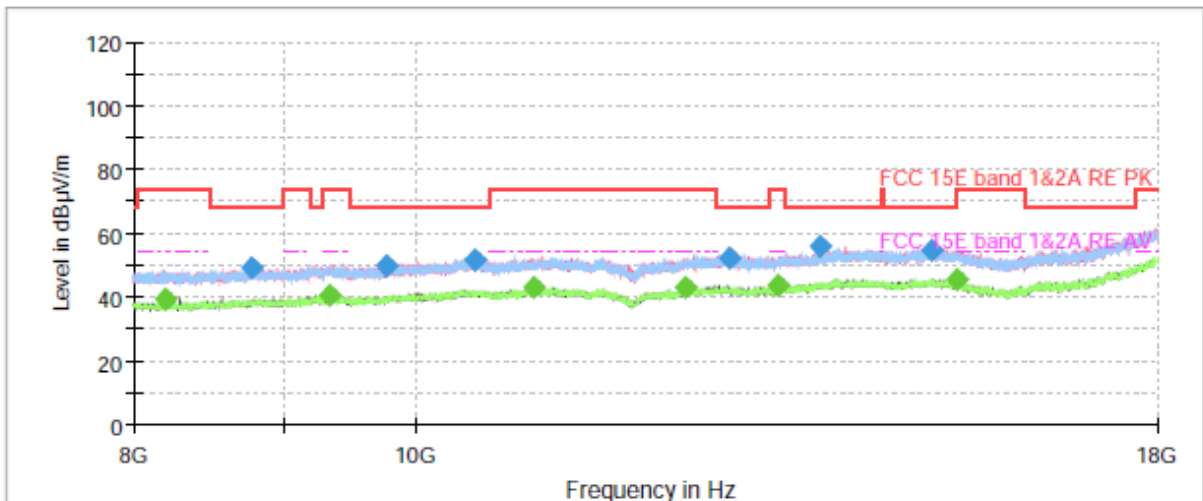

Radiates Emission from 8GHz to 18GHz



Frequency (MHz)	Peak (dBuV/m)	Average (dBuV/m)	Limit (dBuV/m)	Margin (dB)	Height (cm)	Polarization	Azimuth (deg)	Correct Factor (dB)
1034.300000	---	41.65	54.00	12.35	200.0	H	320.0	-10
1295.866667	46.90	---	68.20	21.30	200.0	V	5.0	-8
1689.733333	---	39.27	54.00	14.73	100.0	H	158.0	-6
1956.433333	49.71	---	68.20	18.49	100.0	V	0.0	-5
2518.533333	51.48	---	68.20	16.72	100.0	V	112.0	-4
2812.066667	---	42.05	54.00	11.95	100.0	H	144.0	-3
3437.866667	52.10	---	68.20	16.10	200.0	H	357.0	-3
3988.066667	---	43.54	54.00	10.46	100.0	H	3.0	-1
5146.333333	---	46.53	54.00	7.47	200.0	H	355.0	2
5603.433333	56.42	---	68.20	11.78	200.0	H	357.0	3
6988.033333	59.96	---	68.20	8.24	100.0	H	102.0	7
7695.966667	---	48.98	54.00	5.02	100.0	H	14.0	7

Remark: 1. Correction Factor = Antenna factor+ Insertion loss (cable loss + amplifier gain)

802.11a CH149

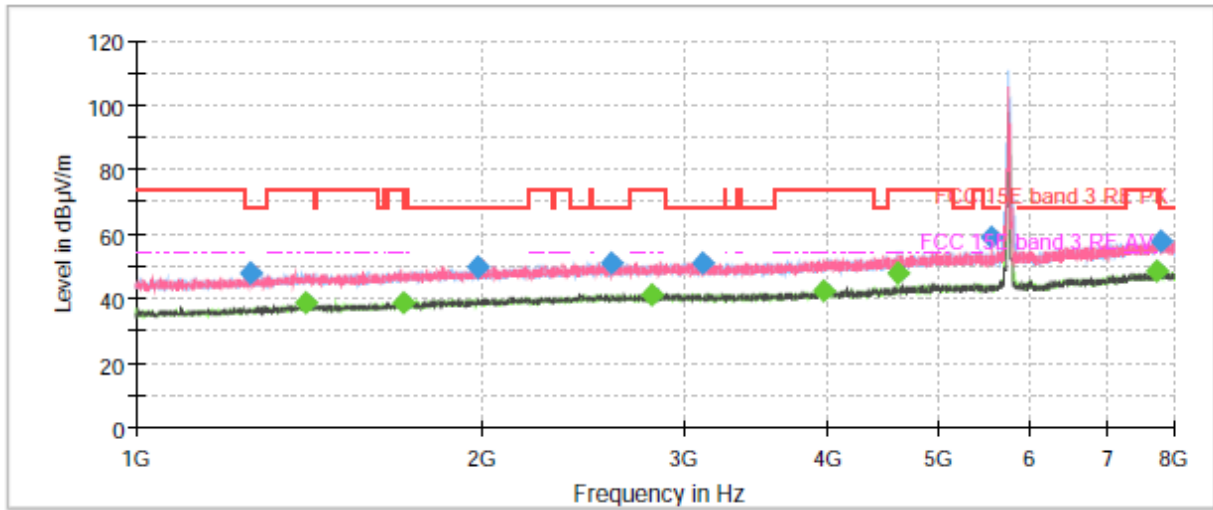

Note: The signal beyond the limit is carrier.
Radiates Emission from 1GHz to 8GHz

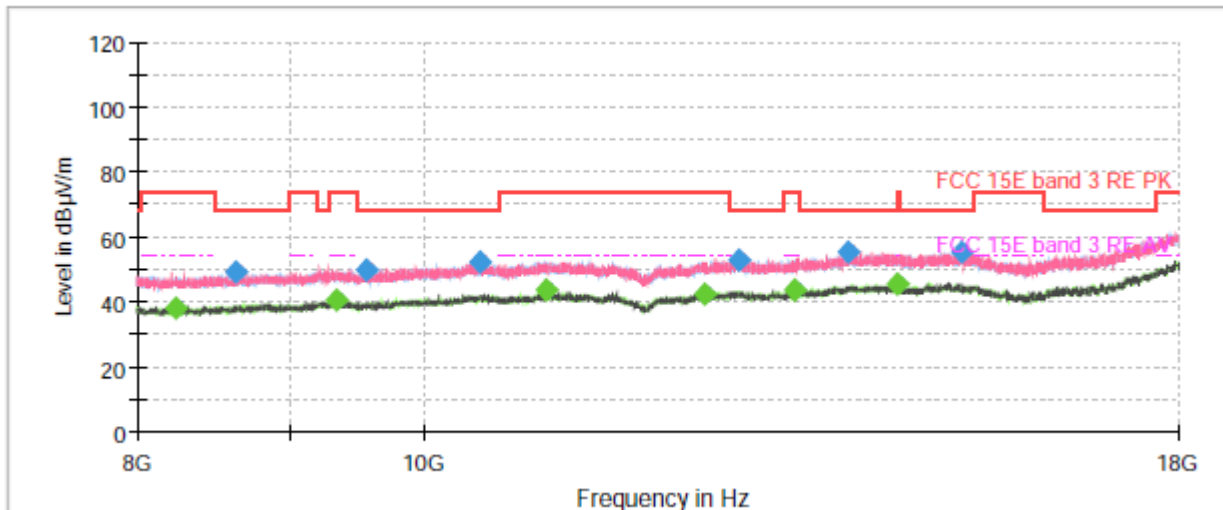

Radiates Emission from 8GHz to 18GHz



Frequency (MHz)	Peak (dBuV/m)	Average (dBuV/m)	Limit (dBuV/m)	Margin (dB)	Height (cm)	Polarization	Azimuth (deg)	Correct Factor (dB)
1258.300000	47.84	---	68.20	20.36	200.0	V	4.0	-8
1405.766667	---	38.49	54.00	15.51	200.0	H	295.0	-7
1706.300000	---	38.95	54.00	15.05	100.0	H	76.0	-6
1983.266667	49.86	---	68.20	18.34	200.0	V	0.0	-5
2593.200000	51.09	---	68.20	17.11	200.0	H	211.0	-4
2811.600000	---	41.21	54.00	12.79	100.0	V	99.0	-3
3112.366667	51.36	---	68.20	16.84	200.0	H	322.0	-3
3966.600000	---	42.59	54.00	11.41	100.0	V	349.0	-1
4595.900000	---	47.84	54.00	6.16	100.0	H	3.0	1
5556.766667	59.02	---	68.20	9.18	200.0	V	0.0	3
7731.200000	---	48.34	54.00	5.66	200.0	V	81.0	7
7804.466667	57.76	---	68.20	10.44	100.0	V	12.0	7

Remark: 1. Correction Factor = Antenna factor+ Insertion loss (cable loss + amplifier gain)

802.11a CH157

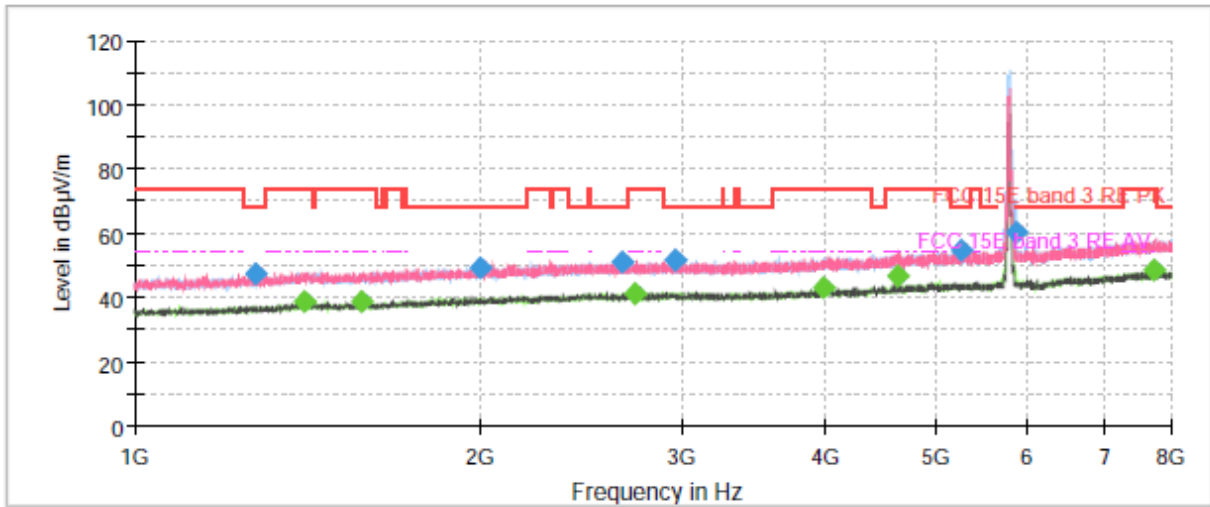

Note: The signal beyond the limit is carrier.
Radiates Emission from 1GHz to 8GHz

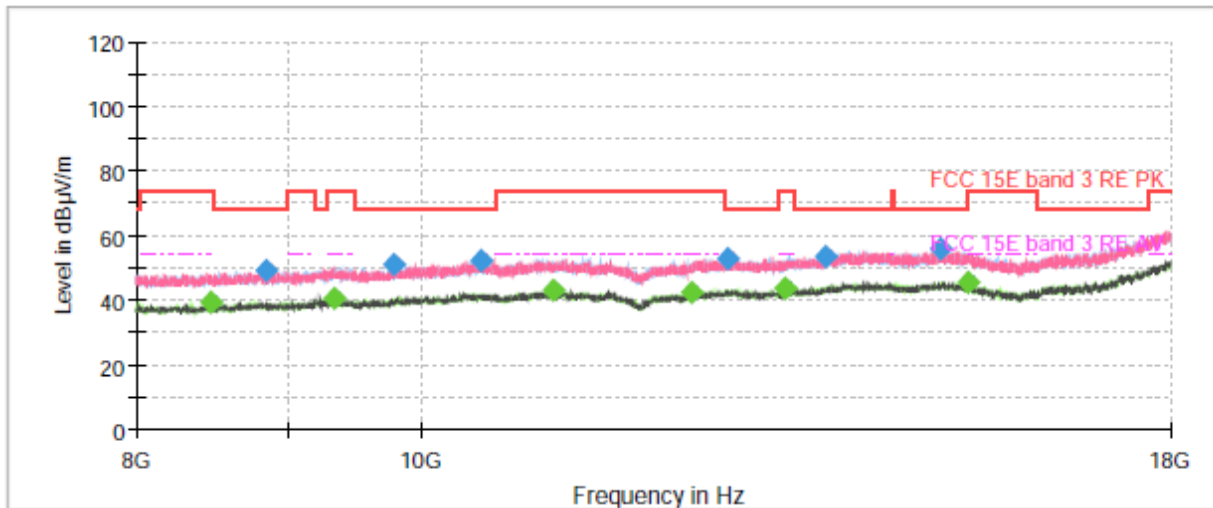

Radiates Emission from 8GHz to 18GHz



Frequency (MHz)	Peak (dBuV/m)	Average (dBuV/m)	Limit (dBuV/m)	Margin (dB)	Height (cm)	Polarization	Azimuth (deg)	Correct Factor (dB)
1272.300000	47.11	---	68.20	21.09	100.0	H	3.0	-8
1405.066667	---	38.82	54.00	15.18	100.0	V	143.0	-7
1579.133333	---	38.90	54.00	15.10	100.0	H	5.0	-6
1998.200000	49.40	---	68.20	18.80	100.0	H	164.0	-5
2660.166667	51.06	---	68.20	17.14	100.0	V	0.0	-3
2727.366667	---	41.27	54.00	12.73	100.0	V	358.0	-4
2959.766667	51.70	---	68.20	16.50	200.0	H	115.0	-3
3984.566667	---	42.86	54.00	11.14	200.0	H	307.0	-1
4627.866667	---	46.97	54.00	7.03	100.0	H	320.0	1
5261.833333	54.75	---	68.20	13.45	200.0	V	165.0	2
5860.333333	60.52	---	68.20	7.68	200.0	H	357.0	4
7737.733333	---	48.45	54.00	5.55	200.0	H	294.0	7

Remark: 1. Correction Factor = Antenna factor+ Insertion loss (cable loss + amplifier gain)

802.11a CH165

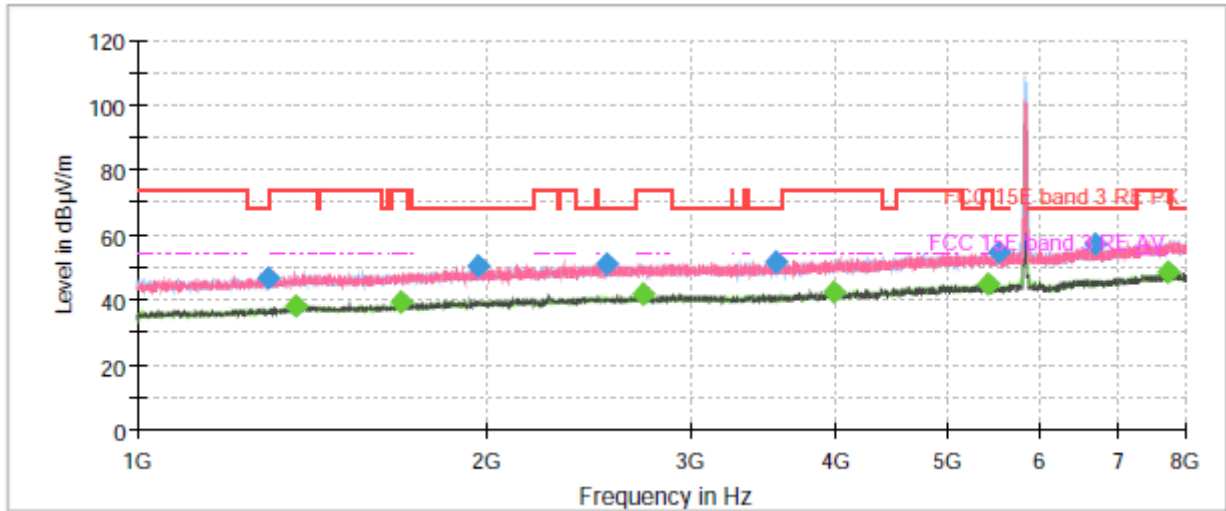

Note: The signal beyond the limit is carrier.
Radiates Emission from 1GHz to 8GHz

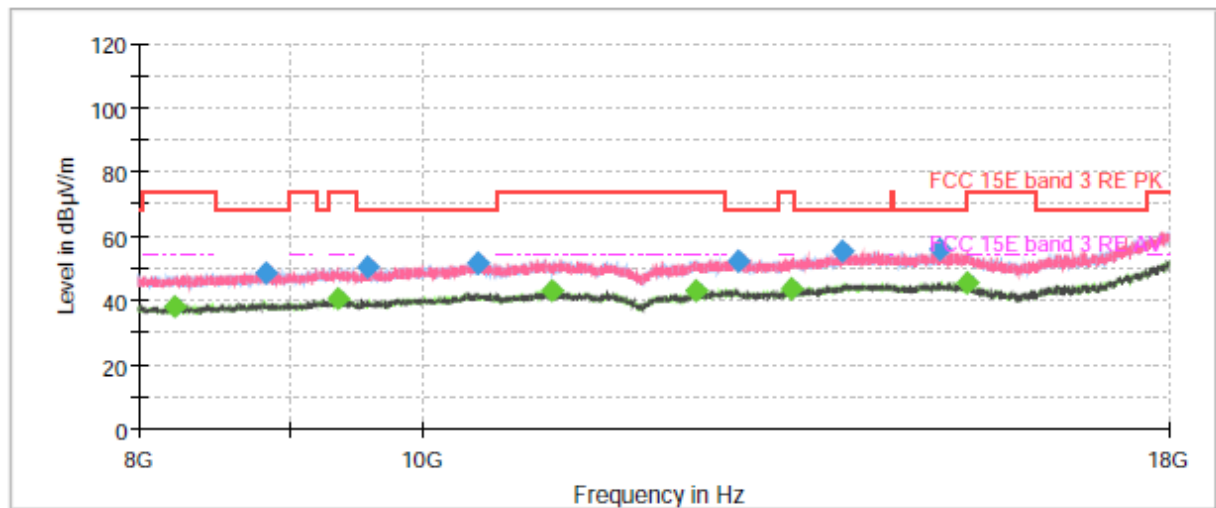

Radiates Emission from 8GHz to 18GHz



Frequency (MHz)	Peak (dBuV/m)	Average (dBuV/m)	Limit (dBuV/m)	Margin (dB)	Height (cm)	Polarization	Azimuth (deg)	Correct Factor (dB)
1293.766667	46.97	---	68.20	21.23	100.0	V	238.0	-8
1369.366667	---	38.41	54.00	15.59	200.0	H	357.0	-7
1687.400000	---	39.35	54.00	14.65	100.0	V	348.0	-6
1963.433333	50.70	---	68.20	17.50	200.0	V	5.0	-5
2538.366667	50.86	---	68.20	17.34	200.0	H	0.0	-4
2728.766667	---	41.62	54.00	12.38	200.0	V	17.0	-4
3548.466667	51.97	---	68.20	16.23	200.0	V	67.0	-3
3991.100000	---	42.66	54.00	11.34	100.0	V	356.0	-1
5399.500000	---	44.99	54.00	9.01	100.0	H	29.0	3
5516.400000	54.73	---	68.20	13.47	200.0	V	161.0	3
6688.433333	57.31	---	68.20	10.89	200.0	H	210.0	6
7745.900000	---	48.35	54.00	5.65	200.0	H	309.0	7

Remark: 1. Correction Factor = Antenna factor+ Insertion loss (cable loss + amplifier gain)

802.11n (HT20) CH36

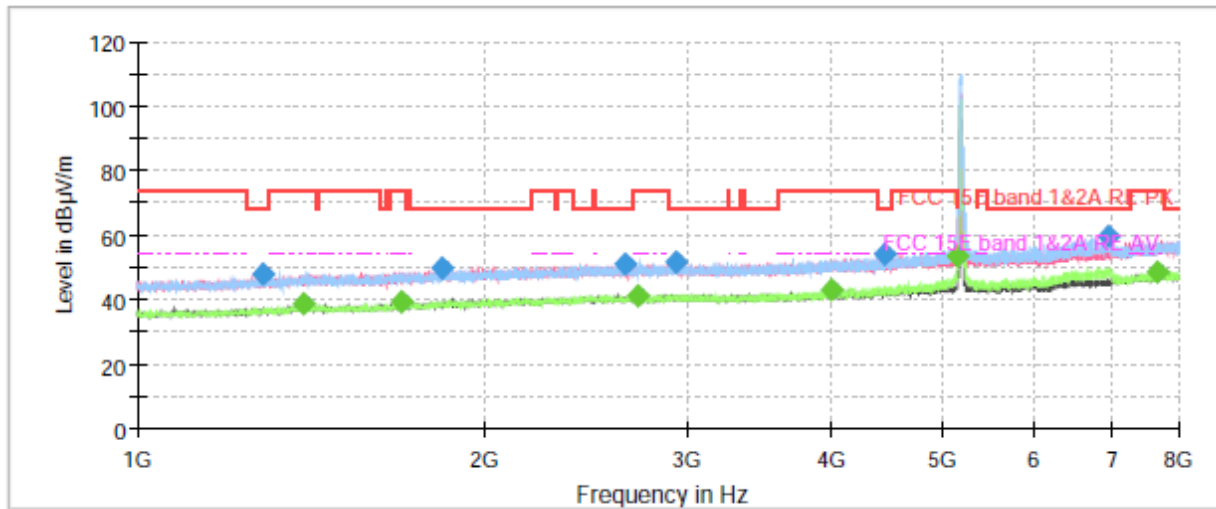

Note: The signal beyond the limit is carrier.
Radiates Emission from 1GHz to 8GHz

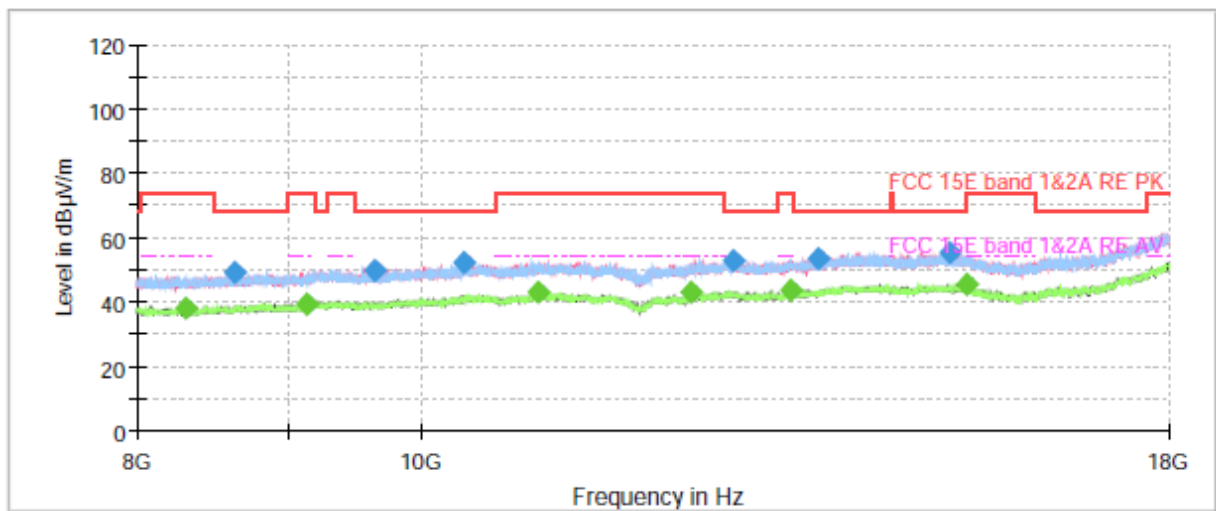

Radiates Emission from 8GHz to 18GHz



Frequency (MHz)	Peak (dBuV/m)	Average (dBuV/m)	Limit (dBuV/m)	Margin (dB)	Height (cm)	Polarization	Azimuth (deg)	Correct Factor (dB)
1283.500000	47.76	---	68.20	20.44	200.0	H	151.0	-8
1395.033333	---	38.78	54.00	15.22	100.0	H	334.0	-7
1696.500000	---	39.10	54.00	14.90	200.0	H	55.0	-6
1836.733333	50.05	---	68.20	18.15	100.0	H	267.0	-6
2651.066667	51.23	---	68.20	16.97	100.0	H	358.0	-4
2720.366667	---	41.32	54.00	12.68	100.0	H	358.0	-4
2935.266667	51.93	---	68.20	16.27	100.0	H	334.0	-3
3999.966667	---	43.32	54.00	10.68	100.0	V	16.0	-1
4441.433333	54.15	---	68.20	14.05	100.0	H	356.0	0
5149.366667	---	53.41	54.00	0.59	200.0	H	0.0	2
6946.733333	59.48	---	68.20	8.72	100.0	H	0.0	7
7654.900000	---	48.43	54.00	5.57	100.0	H	356.0	7

Remark: 1. Correction Factor = Antenna factor+ Insertion loss (cable loss + amplifier gain)

802.11n (HT20) CH40

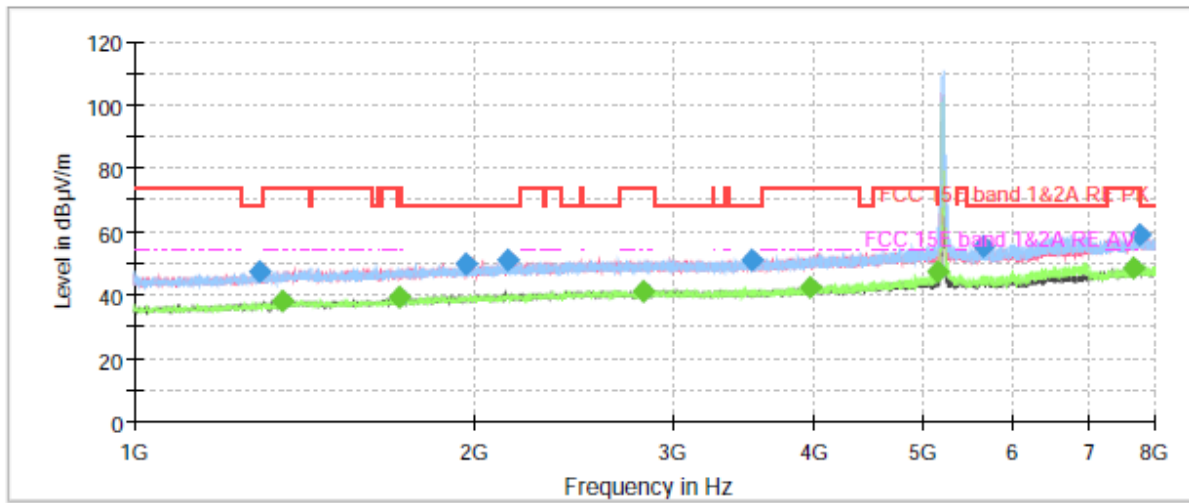

Note: The signal beyond the limit is carrier.
Radiates Emission from 1GHz to 8GHz

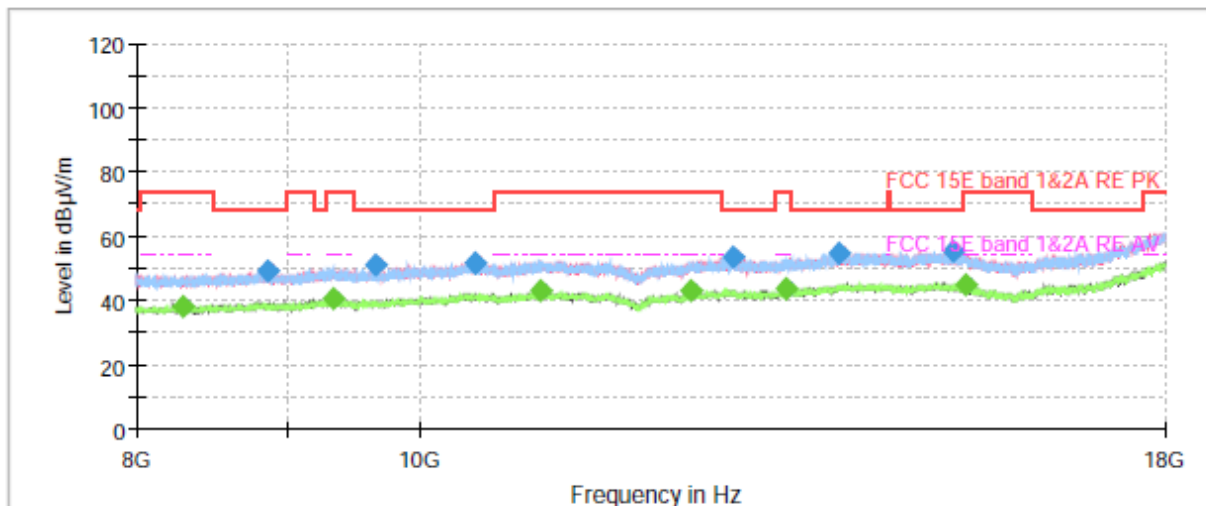

Radiates Emission from 8GHz to 18GHz



Frequency (MHz)	Peak (dBuV/m)	Average (dBuV/m)	Limit (dBuV/m)	Margin (dB)	Height (cm)	Polarization	Azimuth (deg)	Correct Factor (dB)
1291.666667	47.16	---	68.20	21.04	100.0	H	312.0	-8
1353.033333	---	38.31	54.00	15.69	100.0	H	147.0	-7
1718.900000	---	39.35	54.00	14.65	100.0	V	121.0	-6
1966.466667	49.83	---	68.20	18.37	100.0	H	0.0	-5
2137.733333	50.91	---	68.20	17.29	100.0	V	359.0	-4
2822.333333	---	41.51	54.00	12.49	200.0	V	0.0	-3
3527.000000	51.29	---	68.20	16.91	100.0	H	345.0	-3
3973.600000	---	42.63	54.00	11.37	200.0	H	0.0	-1
5147.266667	---	47.22	54.00	6.78	200.0	H	0.0	2
5653.133333	55.57	---	68.20	12.63	100.0	H	0.0	3
7681.033333	---	48.69	54.00	5.31	200.0	V	11.0	7
7777.633333	59.30	---	68.20	8.90	100.0	V	47.0	7

Remark: 1. Correction Factor = Antenna factor+ Insertion loss (cable loss + amplifier gain)

802.11n (HT20) CH48

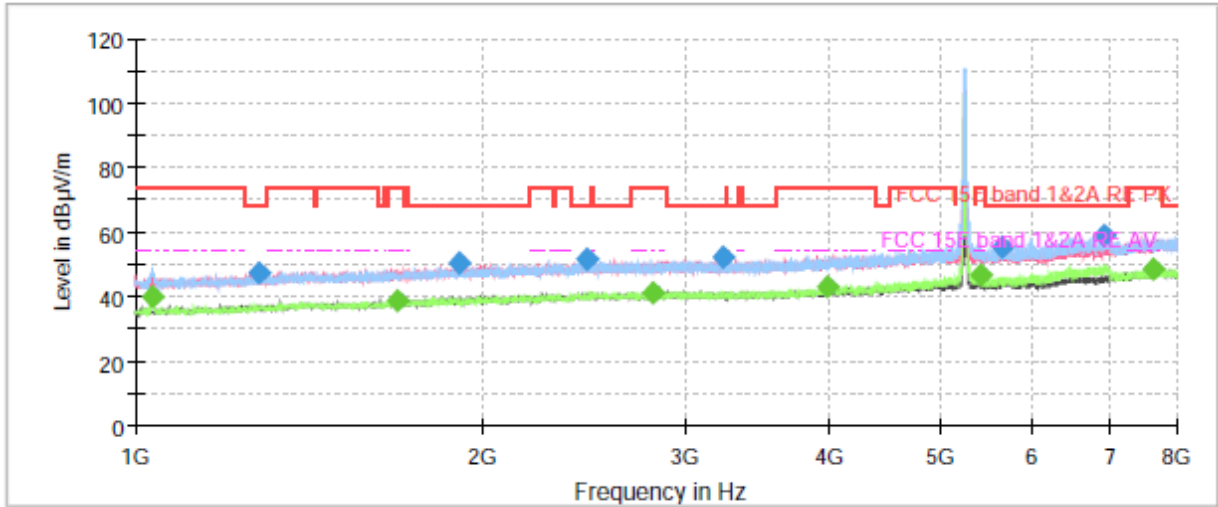

Note: The signal beyond the limit is carrier.
Radiates Emission from 1GHz to 8GHz

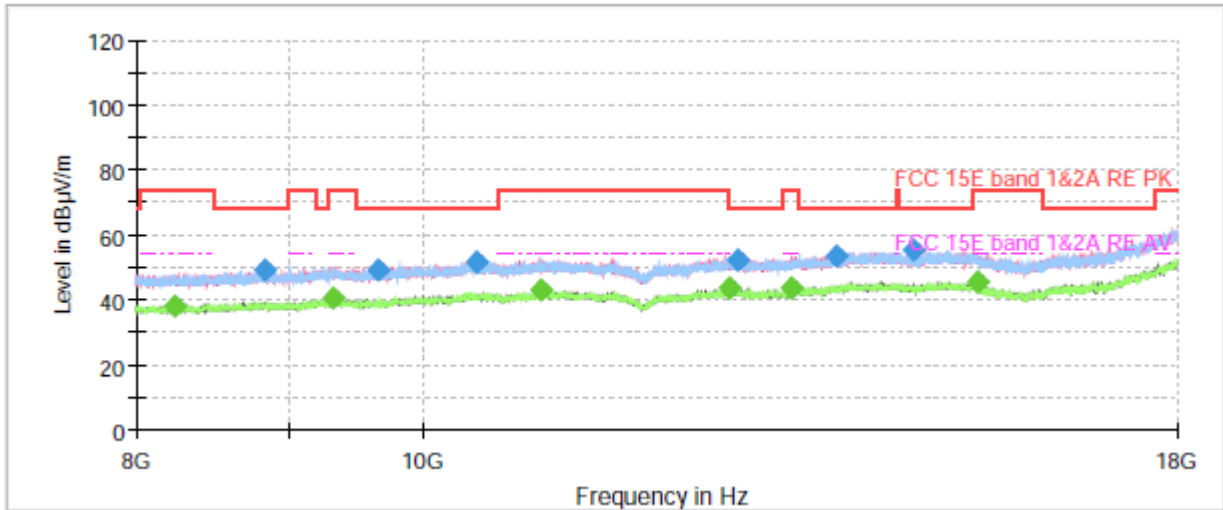

Radiates Emission from 8GHz to 18GHz



Frequency (MHz)	Peak (dBuV/m)	Average (dBuV/m)	Limit (dBuV/m)	Margin (dB)	Height (cm)	Polarization	Azimuth (deg)	Correct Factor (dB)
1035.233333	---	39.74	54.00	14.26	200.0	H	319.0	-10
1280.700000	47.17	---	68.20	21.03	100.0	V	249.0	-8
1688.100000	---	38.87	54.00	15.13	200.0	H	90.0	-6
1906.966667	50.32	---	68.20	17.88	100.0	V	57.0	-5
2458.800000	51.81	---	68.20	16.39	200.0	V	297.0	-4
2815.800000	---	41.39	54.00	12.61	100.0	V	277.0	-3
3238.600000	52.20	---	68.20	16.00	100.0	V	2.0	-3
3986.666667	---	42.77	54.00	11.23	100.0	H	133.0	-1
5408.366667	---	46.51	54.00	7.49	100.0	H	348.0	3
5653.833333	55.64	---	68.20	12.56	100.0	H	0.0	3
6929.466667	59.32	---	68.20	8.88	100.0	H	358.0	7
7623.400000	---	48.42	54.00	5.58	100.0	H	243.0	7

Remark: 1. Correction Factor = Antenna factor+ Insertion loss (cable loss + amplifier gain)

802.11n (HT20) CH149

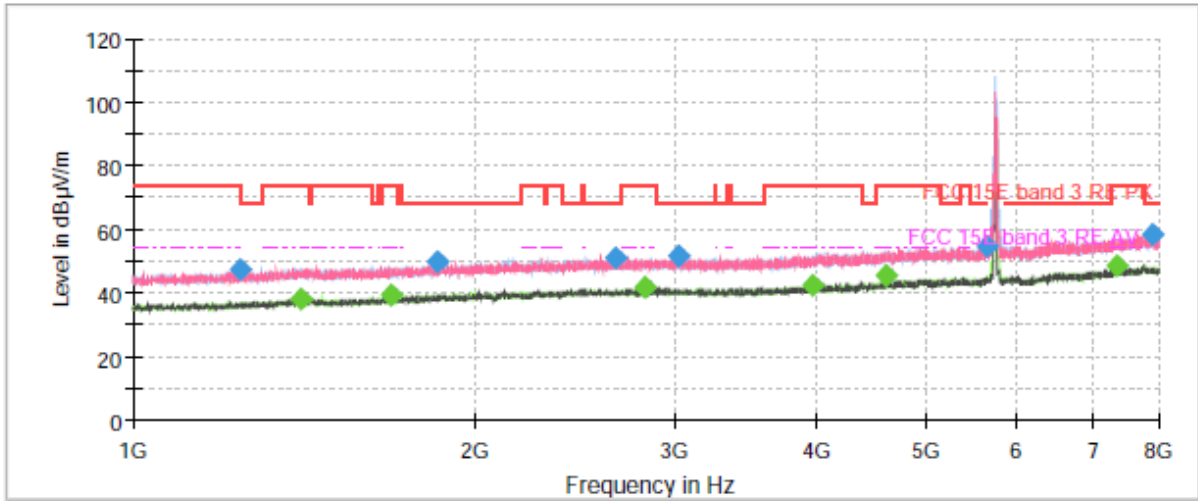

Note: The signal beyond the limit is carrier.
Radiates Emission from 1GHz to 8GHz

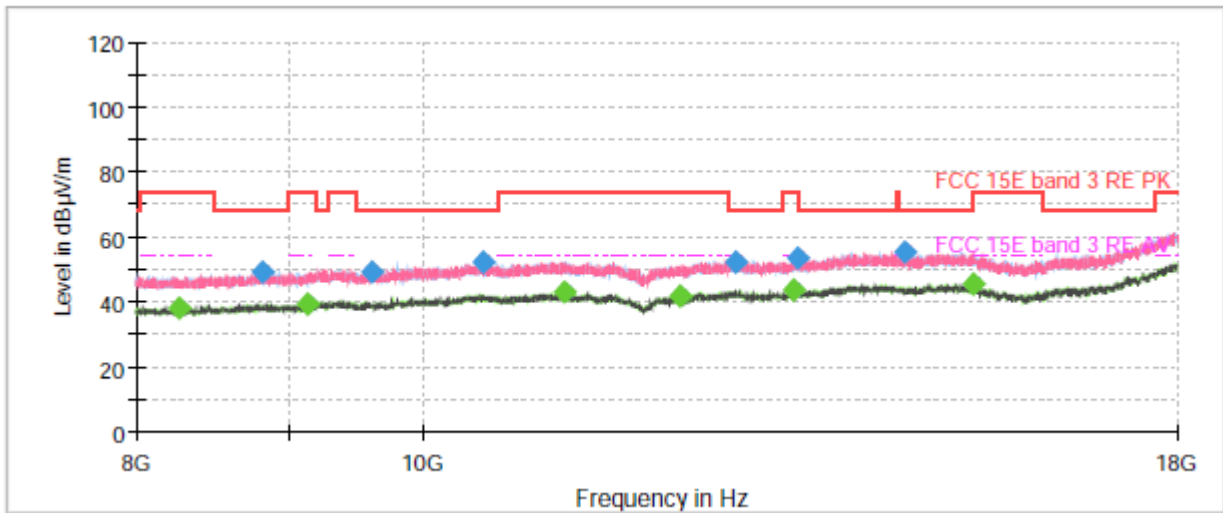

Radiates Emission from 8GHz to 18GHz



Frequency (MHz)	Peak (dBuV/m)	Average (dBuV/m)	Limit (dBuV/m)	Margin (dB)	Height (cm)	Polarization	Azimuth (deg)	Correct Factor (dB)
1244.766667	47.17	---	68.20	21.03	100.0	V	251.0	-8
1405.766667	---	38.45	54.00	15.55	100.0	V	184.0	-7
1690.433333	---	39.20	54.00	14.80	100.0	V	101.0	-6
1850.733333	50.10	---	68.20	18.10	100.0	H	324.0	-5
2663.433333	50.77	---	68.20	17.43	200.0	H	199.0	-3
2828.400000	---	41.72	54.00	12.28	100.0	V	24.0	-3
3017.166667	51.63	---	68.20	16.57	100.0	V	1.0	-3
3971.266667	---	42.24	54.00	11.76	100.0	H	311.0	-1
4595.900000	---	45.44	54.00	8.56	100.0	H	24.0	1
5645.666667	54.79	---	68.20	13.41	100.0	H	38.0	3
7347.133333	---	48.34	54.00	5.66	200.0	V	310.0	7
7910.400000	58.18	---	68.20	10.02	200.0	H	227.0	7

Remark: 1. Correction Factor = Antenna factor+ Insertion loss (cable loss + amplifier gain)

802.11n (HT20) CH157

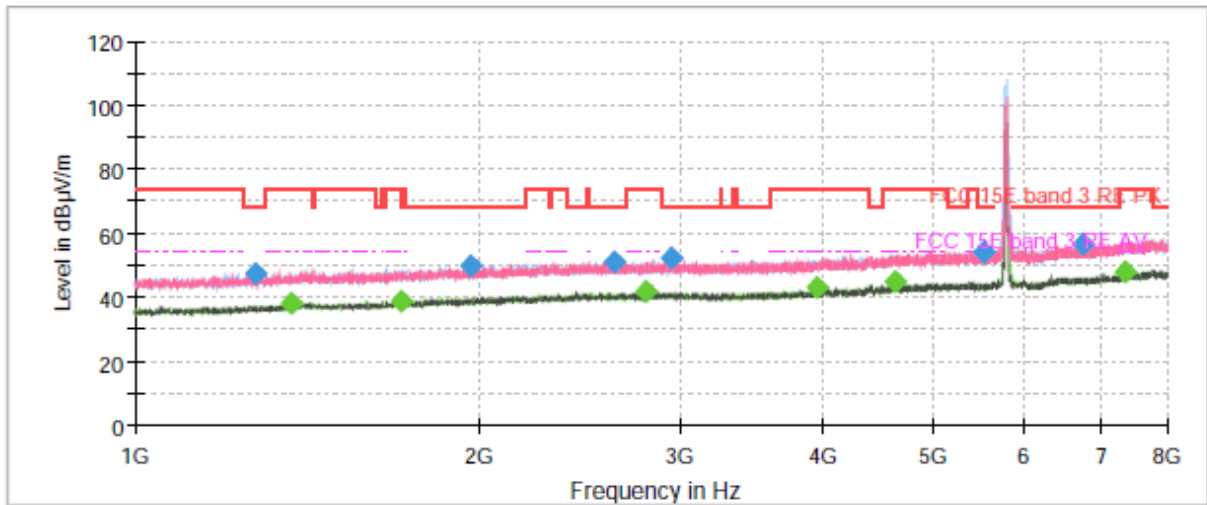

Note: The signal beyond the limit is carrier.
Radiates Emission from 1GHz to 8GHz

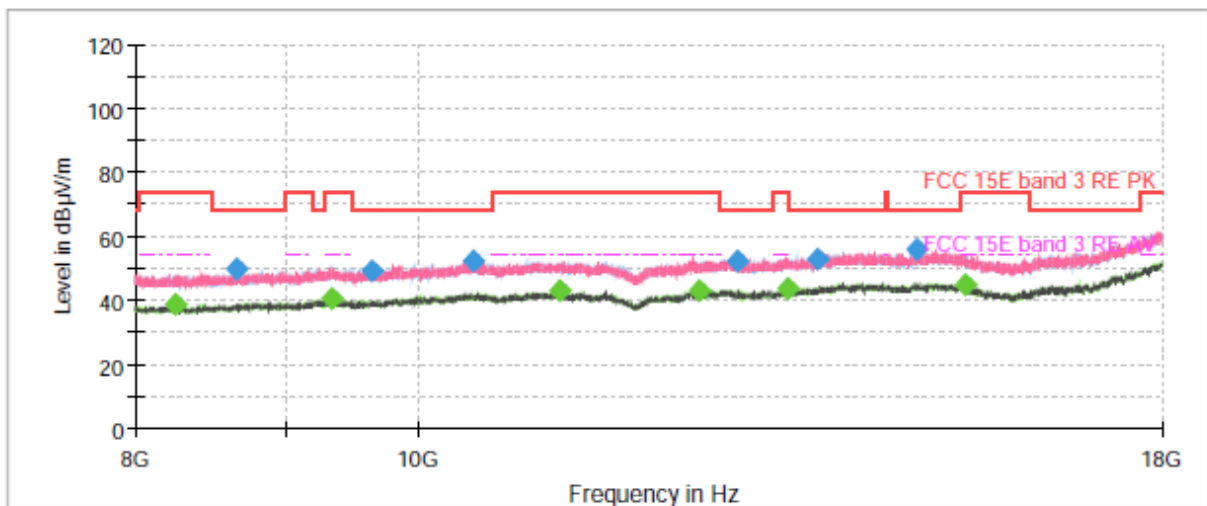

Radiates Emission from 8GHz to 18GHz



Frequency (MHz)	Peak (dBuV/m)	Average (dBuV/m)	Limit (dBuV/m)	Margin (dB)	Height (cm)	Polarization	Azimuth (deg)	Correct Factor (dB)
1274.166667	47.15	---	68.20	21.05	200.0	H	265.0	-8
1370.300000	---	38.17	54.00	15.83	100.0	V	0.0	-7
1707.466667	---	39.06	54.00	14.94	100.0	V	172.0	-6
1967.400000	49.61	---	68.20	18.59	100.0	H	164.0	-5
2624.233333	51.34	---	68.20	16.86	200.0	H	251.0	-4
2800.166667	---	41.70	54.00	12.30	100.0	V	92.0	-3
2948.100000	52.04	---	68.20	16.16	200.0	V	359.0	-3
3955.400000	---	42.98	54.00	11.02	100.0	V	40.0	-1
4627.866667	---	45.19	54.00	8.81	200.0	H	211.0	1
5527.366667	54.42	---	68.20	13.78	100.0	H	247.0	3
6757.966667	56.46	---	68.20	11.74	200.0	V	357.0	6
7337.100000	---	48.16	54.00	5.84	200.0	V	220.0	7

Remark: 1. Correction Factor = Antenna factor+ Insertion loss (cable loss + amplifier gain)

802.11n (HT20) CH165

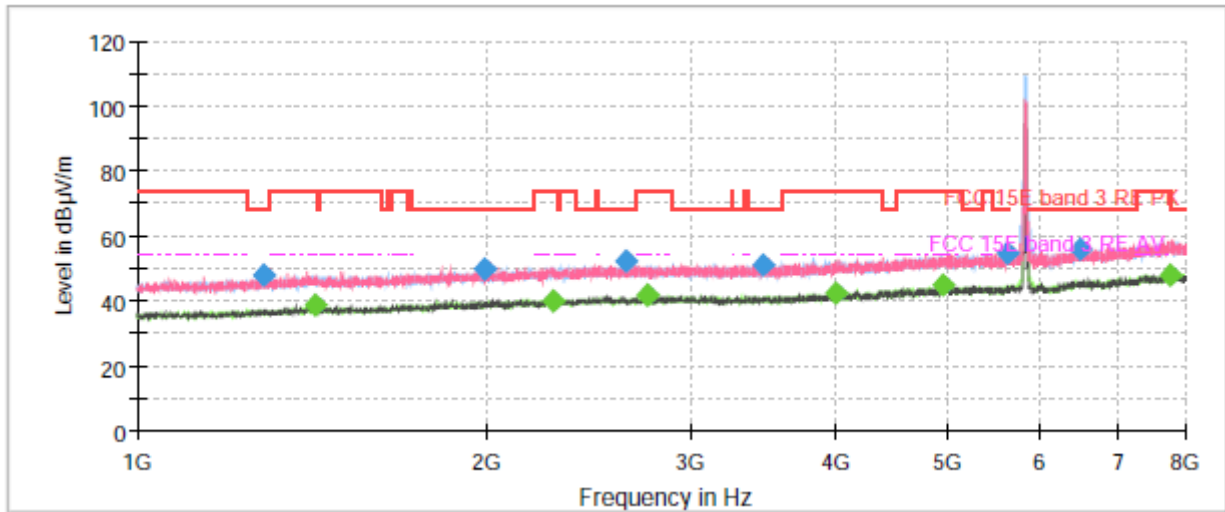

Note: The signal beyond the limit is carrier.
Radiates Emission from 1GHz to 8GHz

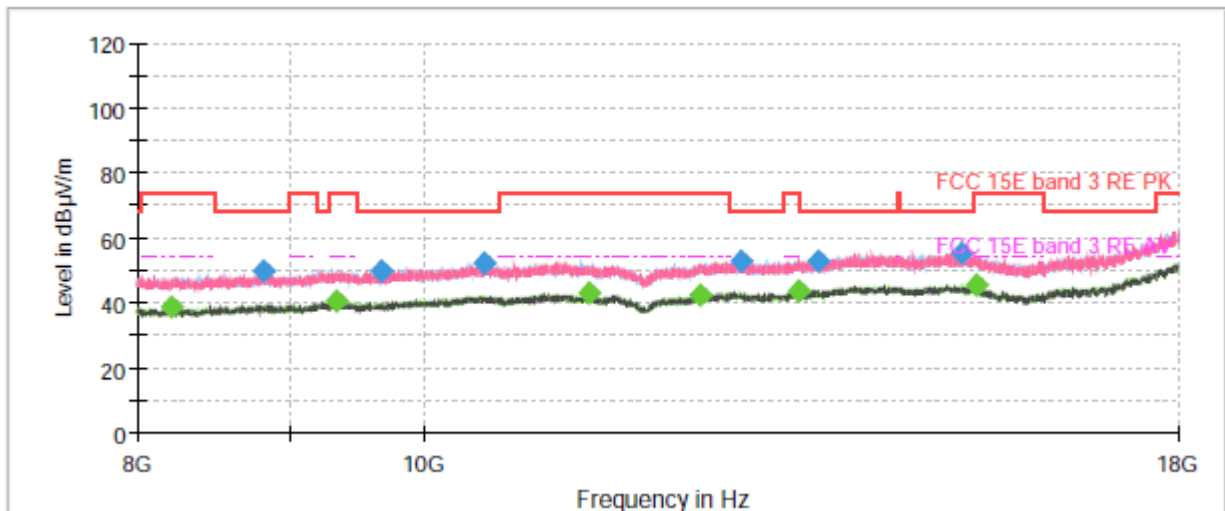

Radiates Emission from 8GHz to 18GHz



Frequency (MHz)	Peak (dBuV/m)	Average (dBuV/m)	Limit (dBuV/m)	Margin (dB)	Height (cm)	Polarization	Azimuth (deg)	Correct Factor (dB)
1285.366667	48.03	---	68.20	20.17	200.0	H	63.0	-8
1422.333333	---	38.73	54.00	15.27	100.0	V	131.0	-7
1992.133333	49.71	---	68.20	18.49	200.0	H	89.0	-5
2283.800000	---	40.29	54.00	13.71	200.0	V	354.0	-4
2633.333333	52.43	---	68.20	15.77	200.0	H	6.0	-4
2754.900000	---	41.77	54.00	12.23	200.0	V	0.0	-4
3462.833333	51.35	---	68.20	16.85	100.0	H	345.0	-3
3997.166667	---	42.76	54.00	11.24	200.0	H	336.0	-1
4941.000000	---	44.75	54.00	9.25	100.0	V	78.0	2
5630.033333	54.89	---	68.20	13.31	100.0	V	91.0	3
6484.966667	55.84	---	68.20	12.36	100.0	V	252.0	6
7749.866667	---	48.24	54.00	5.76	100.0	V	198.0	7

Remark: 1. Correction Factor = Antenna factor+ Insertion loss (cable loss + amplifier gain)

802.11n (HT40) CH38

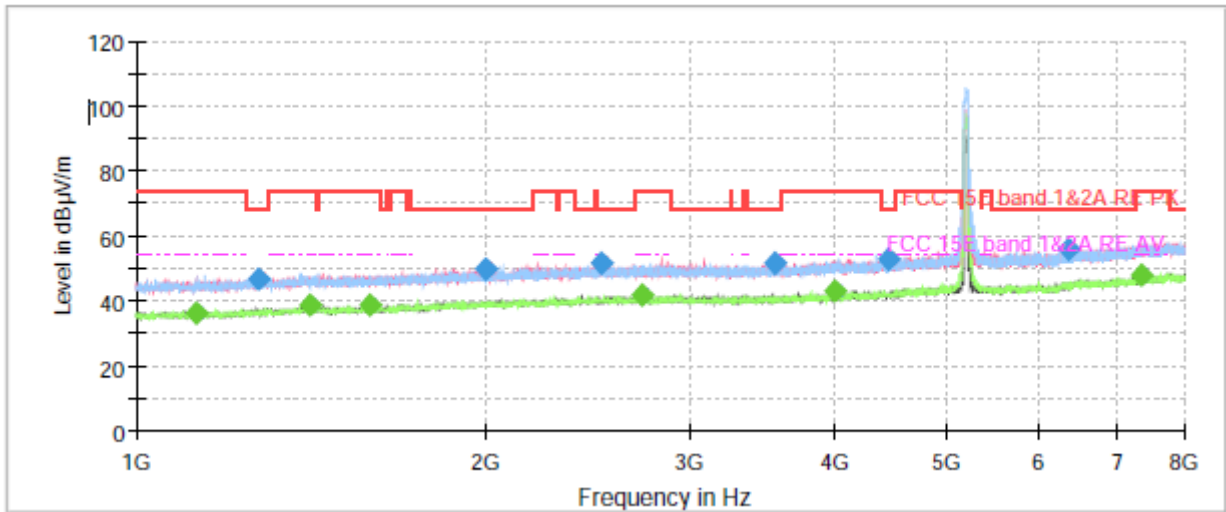

Note: The signal beyond the limit is carrier.
Radiates Emission from 1GHz to 8GHz

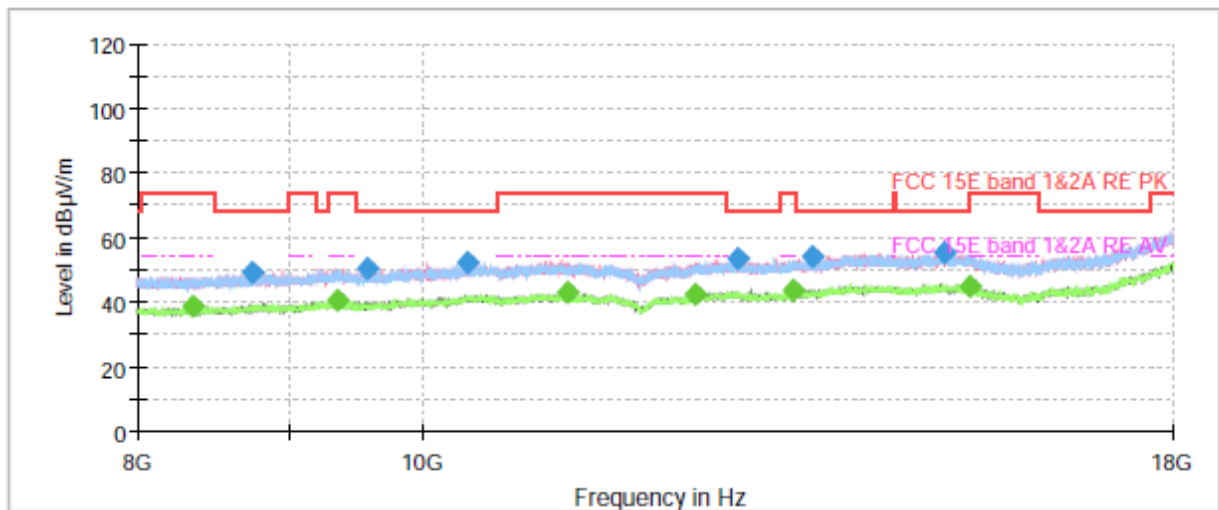

Radiates Emission from 8GHz to 18GHz



Frequency (MHz)	Peak (dBuV/m)	Average (dBuV/m)	Limit (dBuV/m)	Margin (dB)	Height (cm)	Polarization	Azimuth (deg)	Correct Factor (dB)
1126.700000	---	36.56	54.00	17.44	200.0	H	316.0	-9
1273.000000	46.96	---	68.20	21.24	200.0	H	171.0	-8
1413.933333	---	38.54	54.00	15.46	100.0	V	66.0	-7
1591.733333	---	38.97	54.00	15.03	100.0	H	17.0	-6
1998.200000	50.02	---	68.20	18.18	100.0	H	0.0	-5
2513.633333	51.67	---	68.20	16.53	200.0	H	237.0	-4
2724.100000	---	41.99	54.00	12.01	100.0	H	214.0	-4
3552.900000	51.69	---	68.20	16.51	200.0	H	210.0	-3
3998.566667	---	42.98	54.00	11.02	200.0	V	24.0	-1
4452.633333	52.99	---	68.20	15.21	100.0	V	0.0	0
6358.500000	56.09	---	68.20	12.11	100.0	V	243.0	5
7363.000000	---	47.70	54.00	6.30	100.0	V	359.0	7

Remark: 1. Correction Factor = Antenna factor+ Insertion loss (cable loss + amplifier gain)

802.11n (HT40) CH46

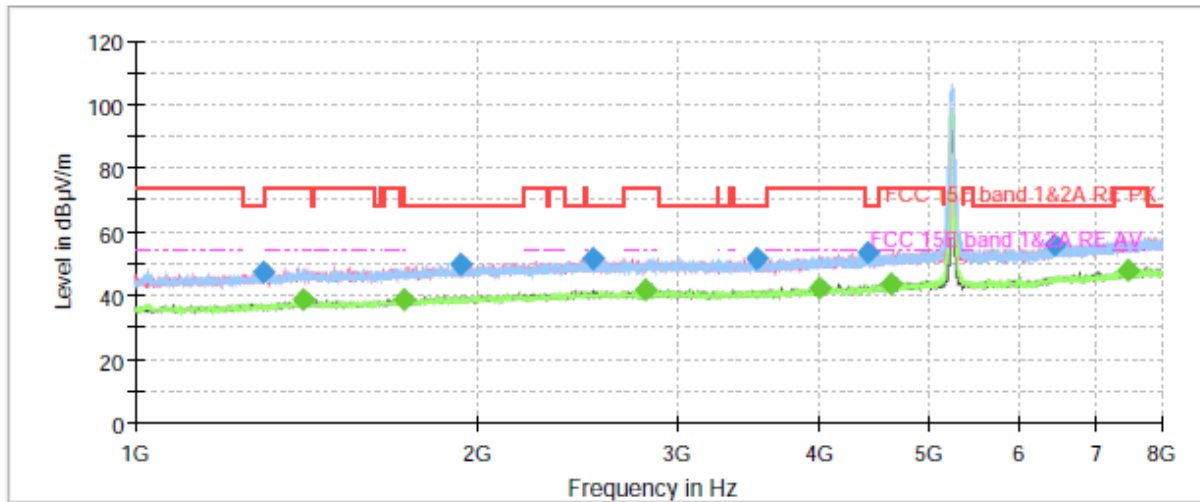

Note: The signal beyond the limit is carrier.
Radiates Emission from 1GHz to 8GHz

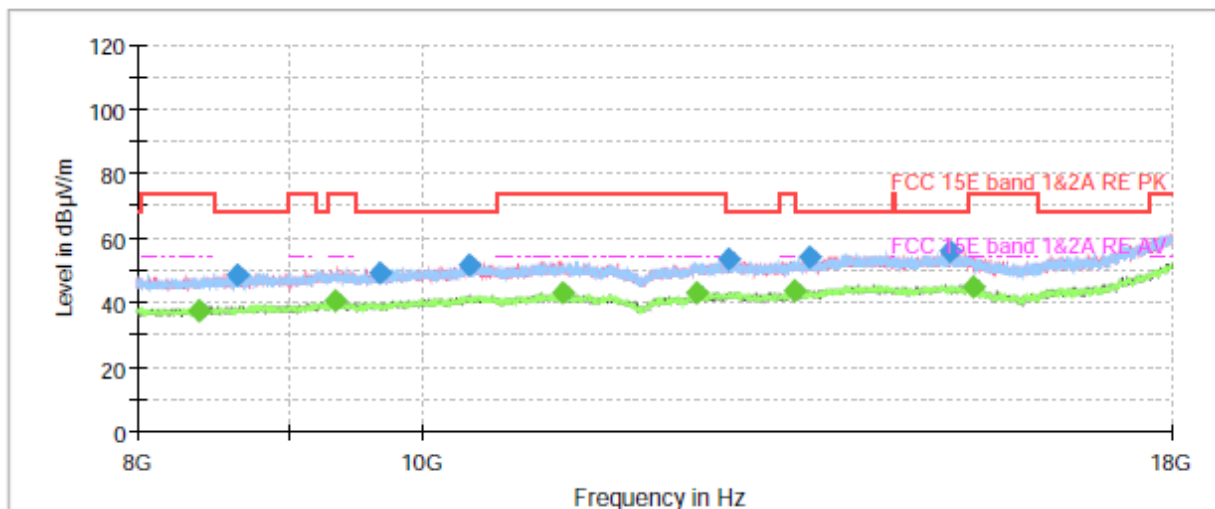

Radiates Emission from 8GHz to 18GHz



Frequency (MHz)	Peak (dBuV/m)	Average (dBuV/m)	Limit (dBuV/m)	Margin (dB)	Height (cm)	Polarization	Azimuth (deg)	Correct Factor (dB)
1295.633333	47.29	---	68.20	20.91	200.0	V	343.0	-8
1405.066667	---	38.66	54.00	15.34	200.0	V	174.0	-7
1719.833333	---	38.91	54.00	15.09	100.0	V	103.0	-6
1929.366667	49.91	---	68.20	18.29	100.0	H	258.0	-5
2522.266667	51.81	---	68.20	16.39	200.0	H	0.0	-4
2813.933333	---	41.68	54.00	12.33	100.0	H	313.0	-3
3521.633333	51.61	---	68.20	16.59	100.0	V	11.0	-3
3997.866667	---	42.69	54.00	11.31	100.0	H	0.0	-1
4416.466667	53.68	---	68.20	14.52	100.0	V	142.0	0
4631.600000	---	43.65	54.00	10.35	200.0	V	354.0	1
6439.466667	56.06	---	68.20	12.14	200.0	V	0.0	5
7469.400000	---	47.70	54.00	6.30	200.0	V	202.0	7

Remark: 1. Correction Factor = Antenna factor+ Insertion loss (cable loss + amplifier gain)

802.11n (HT40) CH151

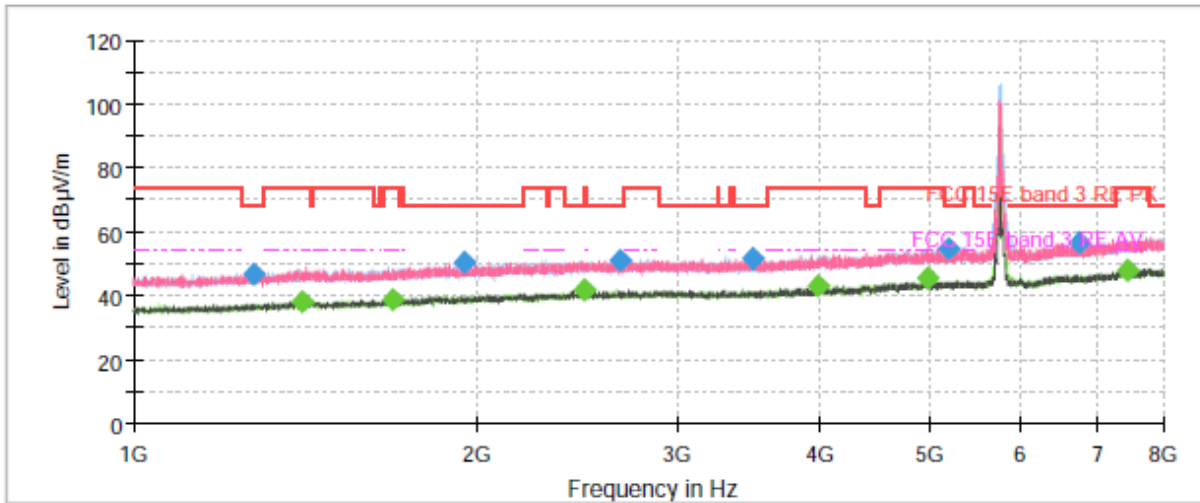

Note: The signal beyond the limit is carrier.
Radiates Emission from 1GHz to 8GHz

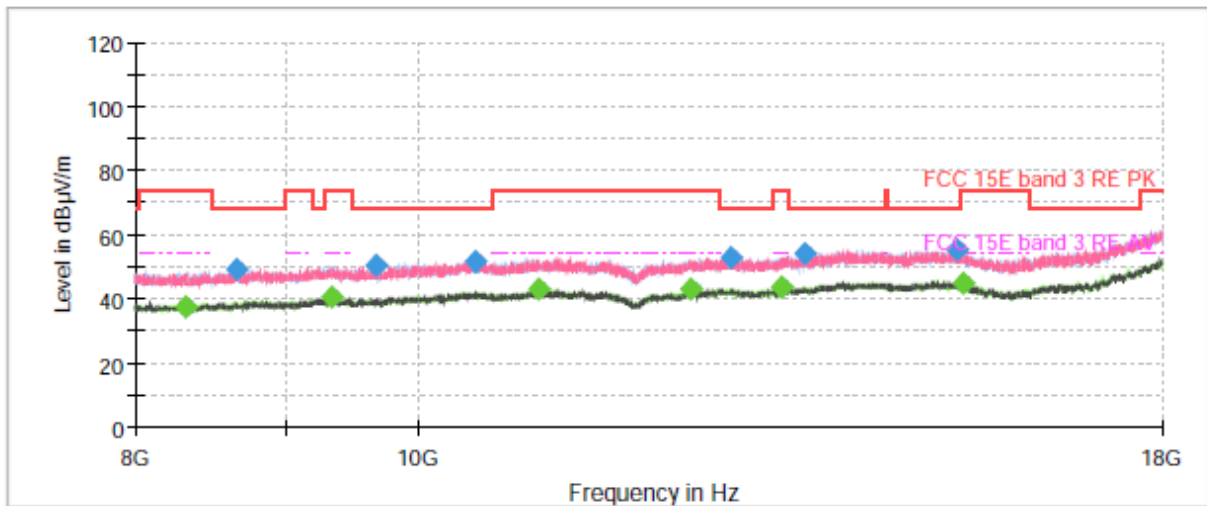

Radiates Emission from 8GHz to 18GHz



Frequency (MHz)	Peak (dBuV/m)	Average (dBuV/m)	Limit (dBuV/m)	Margin (dB)	Height (cm)	Polarization	Azimuth (deg)	Correct Factor (dB)
1274.633333	47.02	---	68.20	21.18	200.0	V	54.0	-8
1403.200000	---	38.29	54.00	15.71	100.0	H	172.0	-7
1689.966667	---	38.99	54.00	15.01	100.0	V	345.0	-6
1952.000000	50.35	---	68.20	17.85	200.0	V	294.0	-5
2484.466667	---	41.68	54.00	12.32	200.0	H	193.0	-4
2668.566667	51.17	---	68.20	17.03	100.0	V	284.0	-3
3491.766667	51.64	---	68.20	16.56	200.0	H	80.0	-3
3990.866667	---	42.80	54.00	11.20	200.0	V	106.0	-1
4966.200000	---	45.29	54.00	8.71	100.0	V	258.0	2
5182.266667	54.60	---	68.20	13.60	200.0	H	286.0	2
6755.166667	56.67	---	68.20	11.53	200.0	V	350.0	6
7431.833333	---	47.81	54.00	6.19	200.0	H	352.0	7

Remark: 1. Correction Factor = Antenna factor+ Insertion loss (cable loss + amplifier gain)

802.11n (HT40) CH159

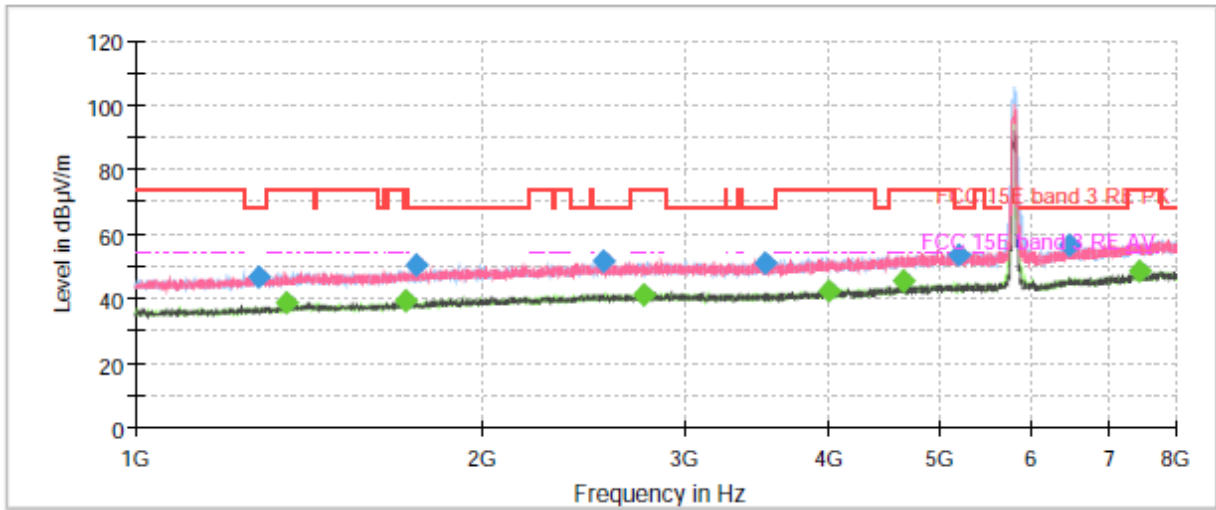

Note: The signal beyond the limit is carrier.
Radiates Emission from 1GHz to 8GHz

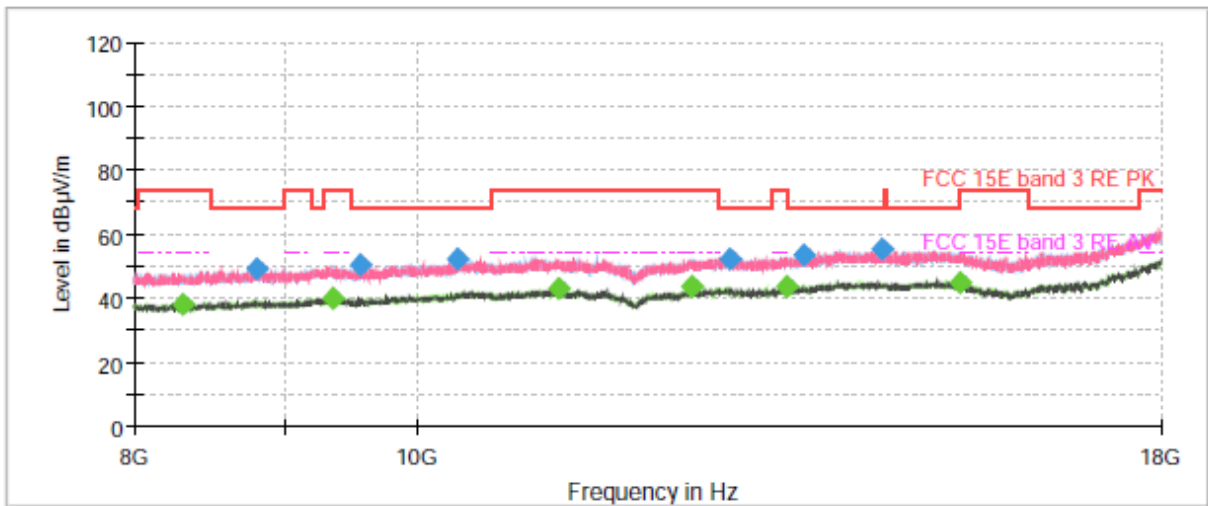

Radiates Emission from 8GHz to 18GHz



Frequency (MHz)	Peak (dBuV/m)	Average (dBuV/m)	Limit (dBuV/m)	Margin (dB)	Height (cm)	Polarization	Azimuth (deg)	Correct Factor (dB)
1279.066667	47.00	---	68.20	21.20	200.0	H	341.0	-8
1351.633333	---	38.68	54.00	15.32	200.0	V	211.0	-7
1719.366667	---	39.35	54.00	14.65	100.0	V	334.0	-6
1752.500000	50.57	---	68.20	17.63	100.0	V	214.0	-6
2549.800000	51.70	---	68.20	16.50	200.0	V	2.0	-4
2759.566667	---	41.47	54.00	12.53	100.0	V	268.0	-4
3527.466667	51.21	---	68.20	16.99	100.0	V	162.0	-3
3999.033333	---	42.41	54.00	11.59	100.0	H	144.0	-1
4636.033333	---	45.24	54.00	8.76	100.0	H	308.0	1
5190.900000	53.57	---	68.20	14.63	200.0	V	75.0	2
6467.466667	56.51	---	68.20	11.69	100.0	V	121.0	6
7444.433333	---	48.35	54.00	5.65	200.0	V	35.0	7

Remark: 1. Correction Factor = Antenna factor+ Insertion loss (cable loss + amplifier gain)

802.11ac (VHT80) CH42

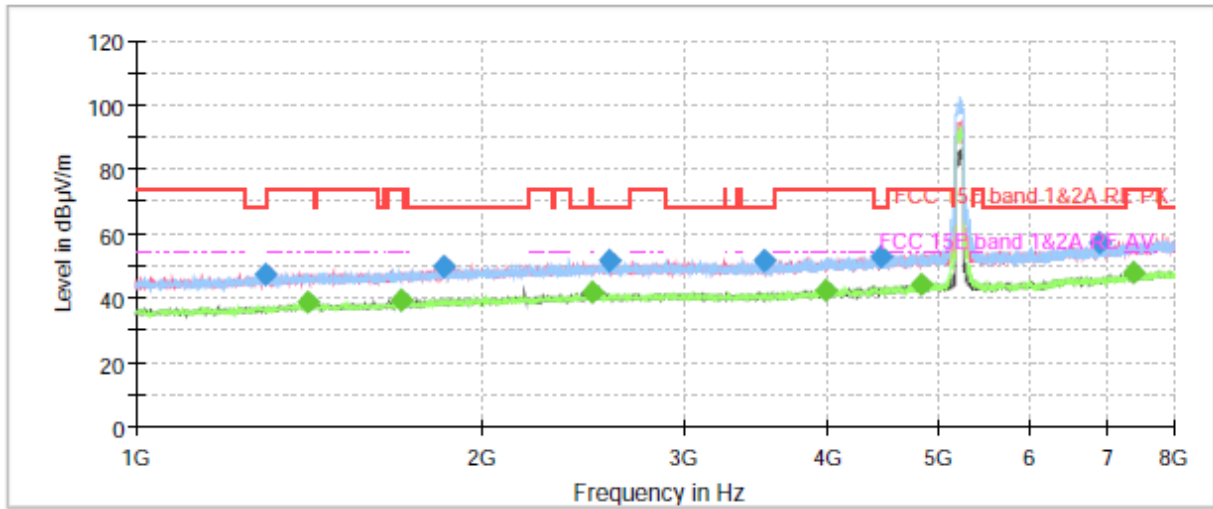

Note: The signal beyond the limit is carrier.
Radiates Emission from 1GHz to 8GHz

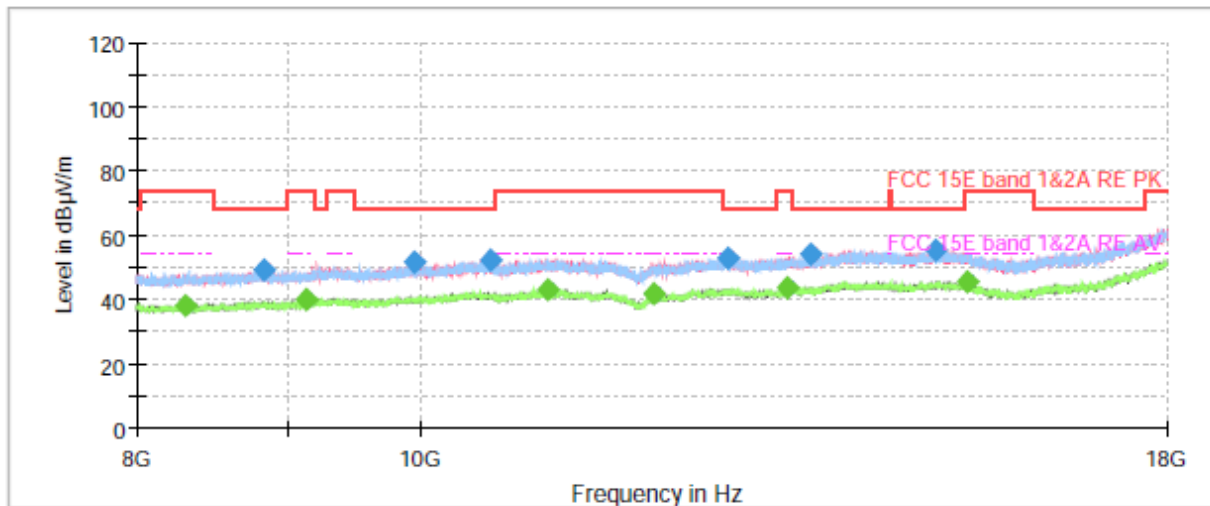

Radiates Emission from 8GHz to 18GHz



Frequency (MHz)	Peak (dBuV/m)	Average (dBuV/m)	Limit (dBuV/m)	Margin (dB)	Height (cm)	Polarization	Azimuth (deg)	Correct Factor (dB)
1298.666667	47.13	---	68.20	21.07	200.0	V	266.0	-8
1412.533333	---	38.46	54.00	15.54	100.0	V	357.0	-7
1701.633333	---	39.25	54.00	14.75	200.0	H	257.0	-6
1850.033333	50.03	---	68.20	18.17	100.0	H	6.0	-5
2495.666667	---	41.74	54.00	12.26	100.0	H	239.0	-4
2577.566667	51.71	---	68.20	16.49	100.0	V	352.0	-4
3522.800000	51.49	---	68.20	16.71	100.0	H	252.0	-3
3981.066667	---	42.62	54.00	11.38	100.0	V	355.0	-1
4450.766667	52.77	---	68.20	15.43	100.0	V	53.0	0
4832.033333	---	44.07	54.00	9.93	200.0	V	103.0	1
6880.466667	57.02	---	68.20	11.18	200.0	V	2.0	7
7368.833333	---	48.13	54.00	5.87	100.0	V	328.0	7

Remark: 1. Correction Factor = Antenna factor+ Insertion loss (cable loss + amplifier gain)

802.11ac (VHT80) CH155

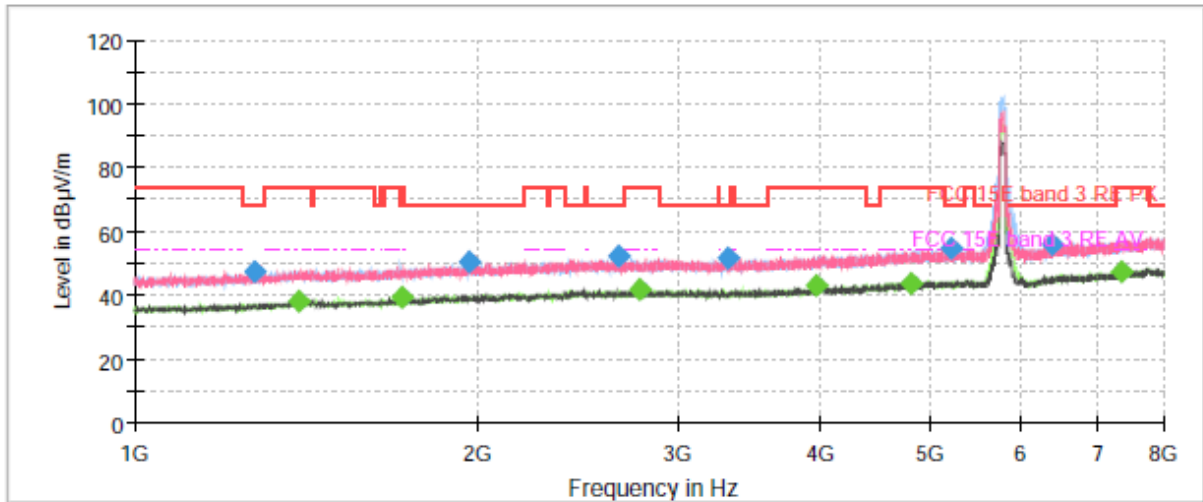

Note: The signal beyond the limit is carrier.
Radiates Emission from 1GHz to 8GHz

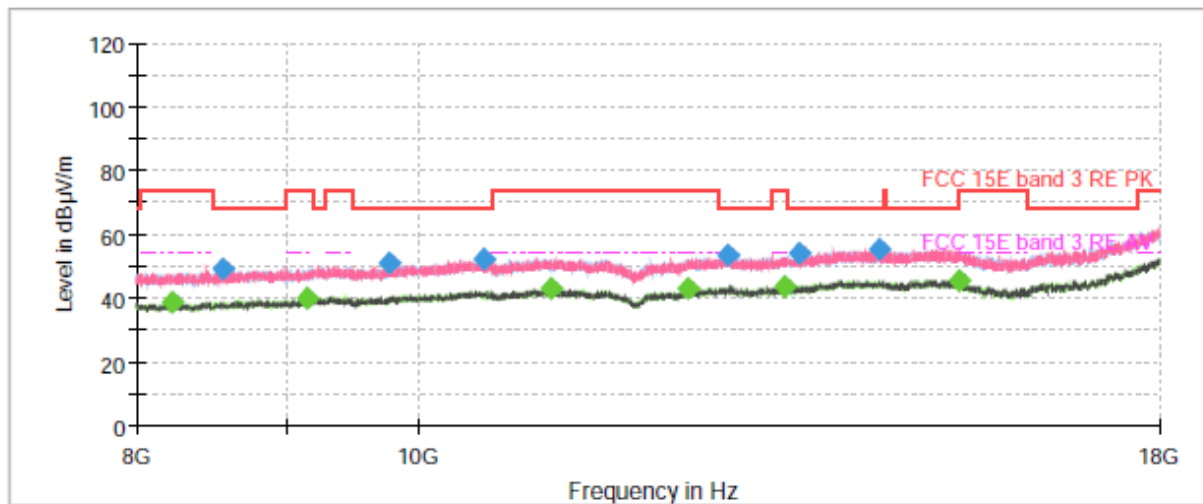

Radiates Emission from 8GHz to 18GHz



Frequency (MHz)	Peak (dBuV/m)	Average (dBuV/m)	Limit (dBuV/m)	Margin (dB)	Height (cm)	Polarization	Azimuth (deg)	Correct Factor (dB)
1273.933333	47.55	---	68.20	20.65	200.0	H	251.0	-8
1391.766667	---	38.33	54.00	15.67	200.0	H	26.0	-7
1718.900000	---	39.20	54.00	14.80	100.0	H	245.0	-6
1963.200000	50.25	---	68.20	17.95	200.0	H	170.0	-5
2655.033333	52.40	---	68.20	15.80	200.0	H	144.0	-4
2778.466667	---	41.70	54.00	12.30	100.0	H	231.0	-4
3318.633333	51.93	---	68.20	16.27	100.0	H	357.0	-3
3969.633333	---	42.92	54.00	11.08	100.0	H	0.0	-1
4794.233333	---	43.87	54.00	10.13	100.0	V	217.0	1
5204.666667	54.82	---	68.20	13.38	100.0	H	0.0	2
6397.700000	55.93	---	68.20	12.27	100.0	V	28.0	5
7353.200000	---	47.28	54.00	6.72	200.0	H	90.0	7

Remark: 1. Correction Factor = Antenna factor+ Insertion loss (cable loss + amplifier gain)



During the test, the Radiates Emission from 18GHz to 40GHz was performed in all modes with all channels, 802.11n (HT20), Channel 36 are selected as the worst condition. The test data of the worst-case condition was recorded in this report.

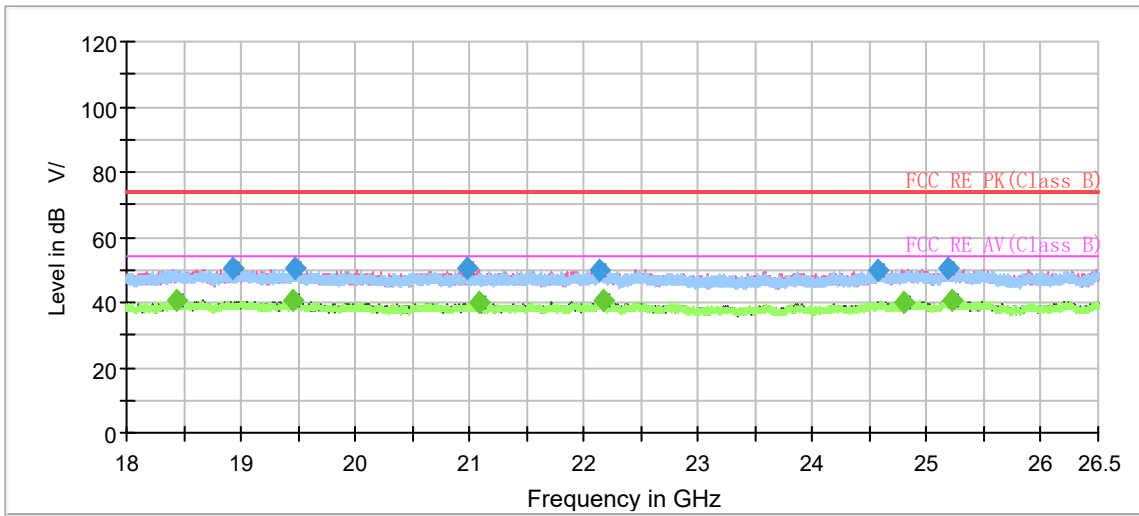

Radiates Emission from 18GHz to 26.5GHz

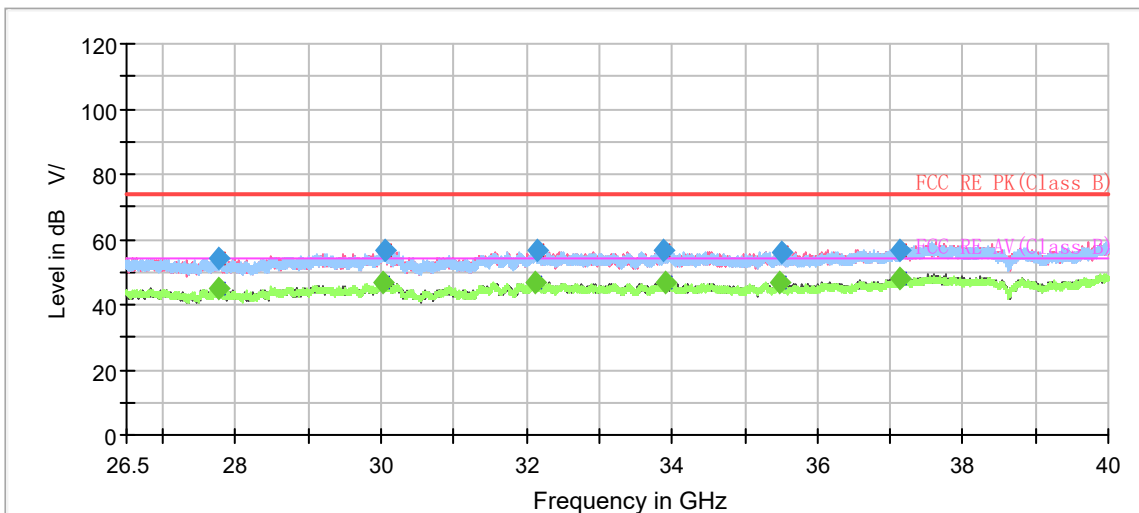

Radiates Emission from 26.5GHz to 40GHz



Frequency (MHz)	Peak (dBuV/m)	Average (dBuV/m)	Limit (dBuV/m)	Margin (dB)	Height (cm)	Polarization	Azimuth (deg)	Correct Factor (dB)
18434.916667	---	40.39	54.00	13.61	100.0	V	7.0	-2
18934.716667	50.22	---	74.00	23.78	100.0	V	307.0	-1
19461.716667	---	40.60	54.00	13.40	100.0	V	245.0	-1
19467.100000	50.69	---	74.00	23.31	200.0	V	271.0	-1
20976.416667	50.30	---	74.00	23.70	100.0	H	74.0	0
21088.050000	---	40.16	54.00	13.84	100.0	H	0.0	0
22135.816667	50.06	---	74.00	23.94	200.0	V	187.0	1
22168.400000	---	40.35	54.00	13.65	200.0	V	179.0	1
24577.583333	50.04	---	74.00	23.96	100.0	H	156.0	3
24792.350000	---	40.07	54.00	13.93	200.0	V	194.0	3
25180.516667	50.16	---	74.00	23.84	100.0	H	95.0	3
25215.083333	---	40.64	54.00	13.36	100.0	V	81.0	3

Remark: 1. Correction Factor = Antenna factor+ Insertion loss (cable loss + amplifier gain)

5.6. Conducted Emission

Ambient condition

Temperature	Relative humidity	Pressure
23°C ~25°C	45%~50%	101.5kPa

Methods of Measurement

The EUT IS placed on a non-metallic table of 80cm height above the horizontal metal reference ground plane. During the test, the EUT was operating in its typical mode. The test method is according to ANSI C63.10. Connect the AC power line of the EUT to the LISN Use EMI receiver to detect the average and Quasi-peak value. RBW is set to 9kHz, VBW is set to 30kHz The measurement result should include both L line and N line.

The test is in transmitting mode.

Test Setup

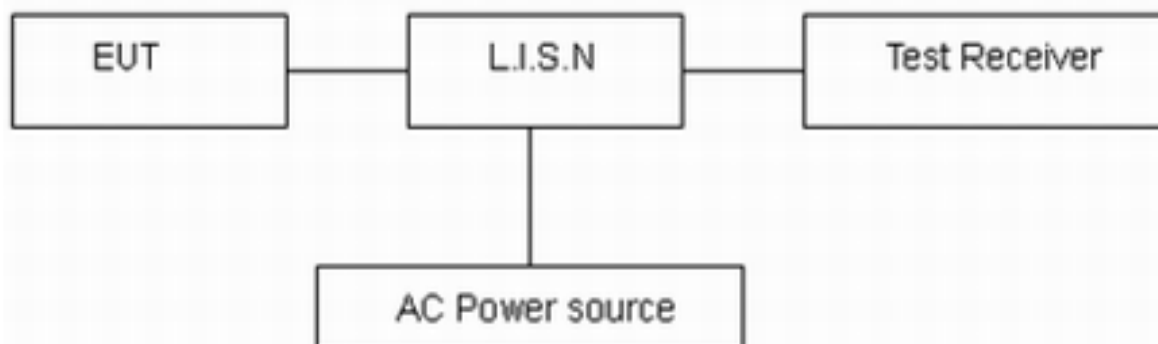

Note: AC Power source is used to change the voltage 110V/60Hz.

Limits

Frequency (MHz)	Conducted Limits(dBμV)	
	Quasi-peak	Average
0.15 - 0.5	66 to 56 *	56 to 46 *
0.5 - 5	56	46
5 - 30	60	50

*: Decreases with the logarithm of the frequency.

Measurement Uncertainty

The assessed measurement uncertainty to ensure 95% confidence level for the normal distribution is with the coverage factor $k = 1.96$, $U = 2.69$ dB.

Test Results:

Following plots, Blue trace uses the peak detection and Green trace uses the average detection. During the test, the Conducted Emission was performed in all modes with all channels, 802.11n (HT 20), Channel 36 are selected as the worst condition. The test data of the worst-case condition was recorded in this report.

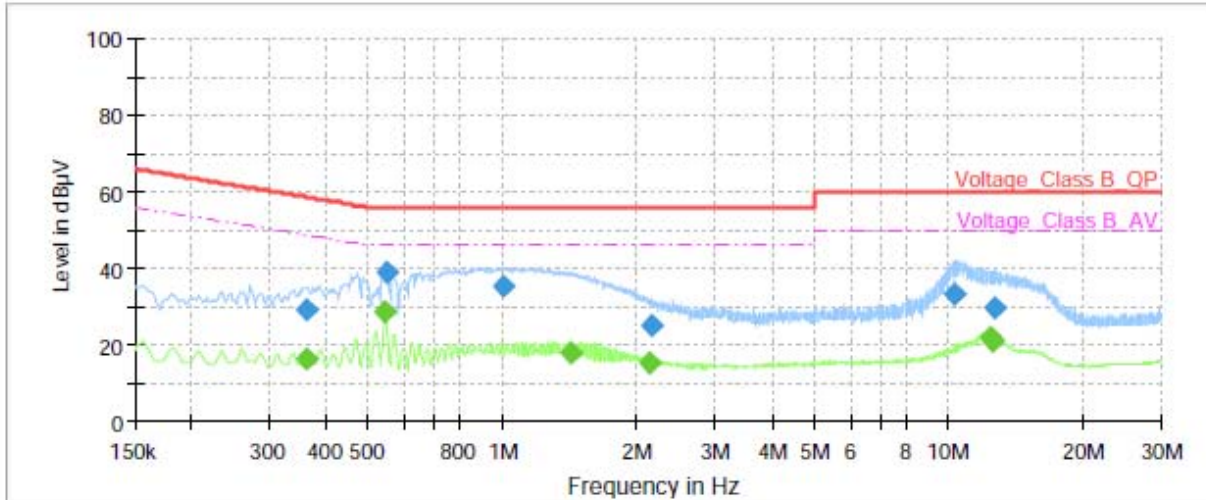

Frequency (MHz)	QuasiPeak (dBµV)	Average (dBµV)	Limit (dBµV)	Margin (dB)	Meas. Time (ms)	Bandwidth (kHz)	Line	Filter	Corr. (dB)
0.36	---	16.37	48.69	32.32	70.0	9.000	L1	ON	21
0.36	29.17	---	58.69	29.52	70.0	9.000	L1	ON	21
0.55	---	28.62	46.00	17.38	70.0	9.000	L1	ON	20
0.55	39.21	---	56.00	16.79	70.0	9.000	L1	ON	20
1.00	35.54	---	56.00	20.46	70.0	9.000	L1	ON	20
1.42	---	18.20	46.00	27.80	70.0	9.000	L1	ON	20
2.13	---	15.16	46.00	30.84	70.0	9.000	L1	ON	20
2.16	25.30	---	56.00	30.70	70.0	9.000	L1	ON	20
10.34	33.13	---	60.00	26.87	70.0	9.000	L1	ON	20
12.38	---	21.92	50.00	28.08	70.0	9.000	L1	ON	20
12.47	---	21.23	50.00	28.77	70.0	9.000	L1	ON	20
12.60	29.56	---	60.00	30.44	70.0	9.000	L1	ON	20

Remark: Correct factor=cable loss + LISN factor

L line Conducted Emission from 150 KHz to 30 MHz

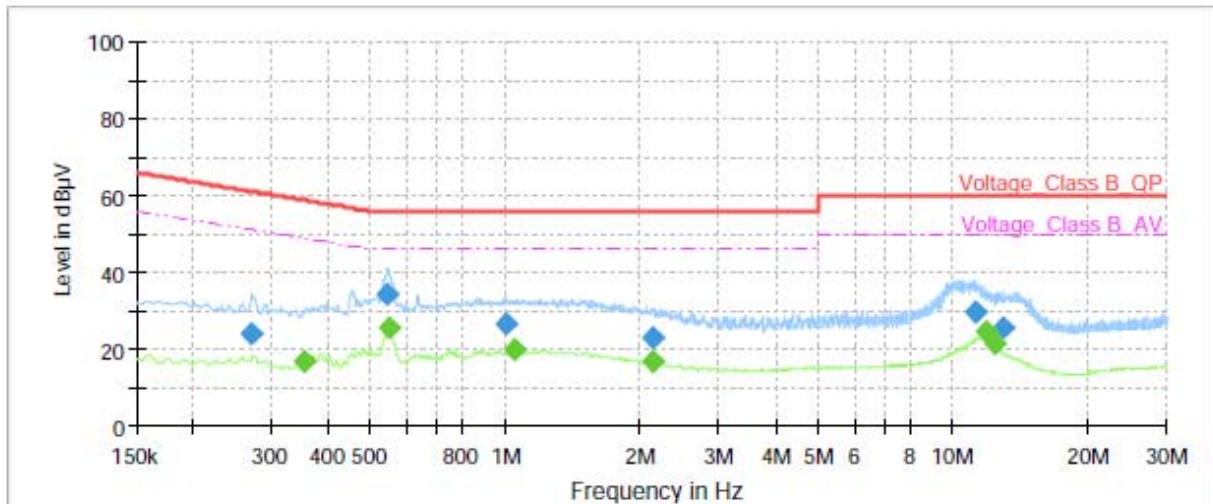

Frequency (MHz)	QuasiPeak (dBµV)	Average (dBµV)	Limit (dBµV)	Margin (dB)	Meas. Time (ms)	Bandwidth (kHz)	Line	Filter	Corr. (dB)
0.27	23.90	---	61.07	37.17	70.0	9.000	N	ON	21
0.36	---	16.91	48.80	31.89	70.0	9.000	N	ON	21
0.55	34.51	---	56.00	21.49	70.0	9.000	N	ON	20
0.55	---	25.66	46.00	20.34	70.0	9.000	N	ON	20
1.00	26.64	---	56.00	29.36	70.0	9.000	N	ON	20
1.05	---	20.24	46.00	25.76	70.0	9.000	N	ON	20
2.13	---	16.73	46.00	29.27	70.0	9.000	N	ON	20
2.14	23.17	---	56.00	32.83	70.0	9.000	N	ON	20
11.22	29.56	---	60.00	30.44	70.0	9.000	N	ON	20
11.82	---	24.82	50.00	25.18	70.0	9.000	N	ON	20
12.41	---	21.43	50.00	28.57	70.0	9.000	N	ON	20
12.94	25.65	---	60.00	34.35	70.0	9.000	N	ON	20

Remark: Correct factor=cable loss + LISN factor

N line Conducted Emission from 150 KHz to 30 MHz



6. Main Test Instruments

Name	Manufacturer	Type	Serial Number	Calibration Date	Expiration Date
Spectrum Analyzer	R&S	FSV40	15195-01-00	2021-05-15	2022-05-14
EMI Test Receiver	R&S	ESCI	100948	2021-05-15	2022-05-14
Loop Antenna	SCHWARZBECK	FMZB1519	1519-047	2020-04-02	2023-04-01
TRILOG Broadband Antenna	SCHWARZBECK	VULB 9163	391	2019-12-16	2022-12-15
Horn Antenna	R&S	HF907	102723	2020-08-11	2023-08-10
Standard Gain Horn	STEATITE	QSH-SL-26-40 -K-15	16779	2019-12-24	2022-12-23
Broadband Horn Antenna	SCHWARZBECK	BBHA 9120D	430	2018-07-07	2023-07-06
EMI Test Receiver	R&S	ESR	101667	2021-05-16	2022-05-15
LISN	R&S	ENV216	101171	2018-12-15	2021-12-14
Spectrum Analyzer	KEYSIGHT	N9020A	MY54420163	2020-12-13	2021-12-12
Power Sensor	KEYSIGHT	U2021XA	MY55240002	2020-12-13	2021-12-12
TEMPERATURE CHAMBER	WEISS	WT2040	582261246600 50	2020-12-13	2021-12-12
WLAN AP	Cisco	Air-AP1262N-A-K9	LDK102073 (FCC ID)	/	/
Power Sensor	R&S	NRP18S	101955	2021-05-15	2022-05-14
DC Power Supply	GWINSTEK	GPS-3030D	GEP882653	2021-05-15	2022-05-14
Software	R&S	EMC32	9.26.0	/	/

*****END OF REPORT *****



ANNEX A: The EUT Appearance

The EUT Appearance are submitted separately.



ANNEX B: Test Setup Photos

The Test Setup Photos are submitted separately.