



RF TEST REPORT

Applicant ZTE Corporation
FCC ID SRQ-WF821B
Product LTE CPE
Brand ZTE
Model WF821/WF821A/WF821+
Report No. RXA1711-0382RF04
Issue Date December 15, 2017

TA Technology (Shanghai) Co., Ltd. tested the above equipment in accordance with the requirements in **FCC CFR47 Part 15C (2017)**. The test results show that the equipment tested is capable of demonstrating compliance with the requirements as documented in this report.

Performed by: Xianqing Li

Approved by: Kai Xu

TA Technology (Shanghai) Co., Ltd.

No.145, Jintang Rd, Tangzhen Industry Park, Pudong Shanghai, China

TEL: +86-021-50791141/2/3

FAX: +86-021-50791141/2/3-8000



TABLE OF CONTENT

1. Test Laboratory	4
1.1. Notes of the test report.....	4
1.2. Test facility	4
1.3. Testing Location.....	5
2. General Description of Equipment under Test.....	6
3. Applied Standards	7
4. Test Configuration	8
5. Test Case Results	9
5.1. Average Power Output –Conducted.....	9
5.2. 6dB Bandwidth	12
5.3. Power Spectral Density	16
5.4. Spurious RF Conducted Emissions.....	23
5.5. Radiated Emissions in the Restricted Band	29
5.6. Radiates Emission	34
5.7. Conducted Emission	62
6. Main Test Instruments	64
ANNEX A: EUT Appearance and Test Setup	65
A.1 EUT Appearance	65
A.2 Test Setup	67



Summary of measurement results

Number	Summary of measurements of results	Clause in FCC rules	Verdict
1	Maximum Average conducted output power	15.247(b)(3)	PASS
2	6 dB bandwidth	15.247(a)(2)	PASS
3	Power spectral density	15.247(e)	PASS
4	Spurious RF Conducted Emissions	15.247(d)	PASS
5	Radiated Emissions in restricted frequency bands	15.247(d),15.205,15.209	PASS
6	Radiated Emissions	15.247(d),15.205,15.209	PASS
7	Conducted Emissions	15.207	PASS

Date of Testing: December 1, 2017 ~ December 14, 2017

1. Test Laboratory

1.1. Notes of the test report

This report shall not be reproduced in full or partial, without the written approval of **TA technology (shanghai) co., Ltd.** The results documented in this report apply only to the tested sample, under the conditions and modes of operation as described herein .Measurement Uncertainties were not taken into account and are published for informational purposes only. This report is written to support regulatory compliance of the applicable standards stated above.

1.2. Test facility

CNAS (accreditation number: L2264)

TA Technology (Shanghai) Co., Ltd. has obtained the accreditation of China National Accreditation Service for Conformity Assessment (CNAS).

FCC (Designation number: CN1179, Test Firm Registration Number: 446626)

TA Technology (Shanghai) Co., Ltd. has been listed on the US Federal Communications Commission list of test facilities recognized to perform electromagnetic emissions measurements.

IC (recognition number is 8510A)

TA Technology (Shanghai) Co., Ltd. has been listed by industry Canada to perform electromagnetic emission measurement.

VCCI (recognition number is C-4595, T-2154, R-4113, G-10766)

TA Technology (Shanghai) Co., Ltd. has been listed by industry Japan to perform electromagnetic emission measurement.

A2LA (Certificate Number: 3857.01)

TA Technology (Shanghai) Co., Ltd. has been listed by American Association for Laboratory Accreditation to perform electromagnetic emission measurement.



1.3. Testing Location

Company: TA Technology (Shanghai) Co., Ltd.
Address: No.145, Jintang Rd, Tangzhen Industry Park, Pudong
City: Shanghai
Post code: 201201
Country: P. R. China
Contact: Xu Kai
Telephone: +86-021-50791141/2/3
Fax: +86-021-50791141/2/3-8000
Website: <http://www.ta-shanghai.com>
E-mail: xukai@ta-shanghai.com

2. General Description of Equipment under Test

Client Information

Applicant	ZTE Corporation
Applicant address	ZTE Plaza, Keji Road South, Hi-Tech, Industrial Park, Nanshan District, Shenzhen, Guangdong, P.R.China
Manufacturer	ZTE Corporation
Manufacturer address	ZTE Plaza, Keji Road South, Hi-Tech, Industrial Park, Nanshan District, Shenzhen, Guangdong, P.R.China

General information

EUT Description	
Model	WF821/WF821A/WF821+
IMEI	6212017480400004
Hardware Version	V5.0
Software Version	WF821_V1.0.0B01
Power Supply	AC adapter
Antenna Type	Internal Antenna
Antenna Gain	3.00 dBi
additional beamforming gain	0 dB
Test Mode	802.11b 802.11g, 802.11n(HT20/HT40);
Modulation Type	802.11b: DSSS; 802.11g/n(HT20/HT40): OFDM
Max. Conducted Power	Wi-Fi 2.4G :20.94dBm
Operating Frequency Range(s)	802.11b/g/n(HT20): 2412 ~ 2462 MHz 802.11n(HT40): 2422 ~ 2452 MHz
EUT Accessory	
Adapter	Manufacturer: AQUILSTARPRECISIONINDUSTRIAL (SHENZHEN)CO., LTD Model: ASSA65A-120100
Note: The information of the EUT is declared by the manufacturer.	



3. Applied Standards

According to the specifications of the manufacturer, it must comply with the requirements of the following standards:

Test standards

- **FCC CFR47 Part 15C (2017) Radio Frequency Devices**
- **ANSI C63.10 (2013)**
- **KDB 558074 D01 DTS Meas Guidance v04**
- **KDB 662911 D01 Multiple Transmitter Output v02r01**

4. Test Configuration

Test Mode

The EUT has been associated with peripherals and configuration operated in a manner tended to maximize its emission characteristics in a typical application.

The radiated emission was measured in the following position: EUT stand-up position (Z axis), lie-down position (X, Y axis). The worst emission was found in stand-up position (Z axis) and the worst case was recorded.

In order to find the worst case condition, Pre-tests are needed at the presence of different data rate. Preliminary tests have been done on all the configuration for confirming worst case. Data rate below means worst-case rate of each test item.

The test software is used artgui

Worst-case data rates are shown as following table.

Band	Data Rate		
	Antenna 1	Antenna 2	MIMO
802.11b	1 Mbps	1 Mbps	/
802.11g	6 Mbps	6 Mbps	/
802.11n HT20	MCS0	MCS0	MCS8
802.11n HT40	MCS0	MCS0	MCS8

The worst case Antenna mode for each of the following tests for Wi-Fi:

Test Cases	Antenna 1	Antenna 2	MIMO
Average Power Output –Conducted	802.11b/g	802.11b/g	802.11n HT20 802.11n HT40
6dB Bandwidth	--	802.11b/g	802.11n HT20 802.11n HT40
Power Spectral Density	802.11b/g	802.11b/g	802.11n HT20 802.11n HT40
Spurious RF Conducted Emissions	--	802.11b/g	802.11n HT20 802.11n HT40
Radiates Emission in the Restricted Band	--	802.11b/g	802.11n HT20 802.11n HT40
Radiates Emission	--	802.11b/g	802.11n HT20 802.11n HT40
Conducted Emission	--	802.11b/g	802.11n HT20 802.11n HT40

5. Test Case Results

5.1. Average Power Output –Conducted

Ambient condition

Temperature	Relative humidity	Pressure
23°C ~25°C	45%~50%	101.5kPa

Methods of Measurement

During the process of the testing, The EUT was connected to Spectrum Analyzer with a known loss. The EUT is max power transmission with proper modulation. The Average detector is used. We use Maximum Average Conducted Output Power Level Method in KDB 558074 D01/KDB662911 D01 for this test.

The conducted Power is measured at each antenna port. The measured results at the various antenna ports are then summed mathematically.

Test Setup

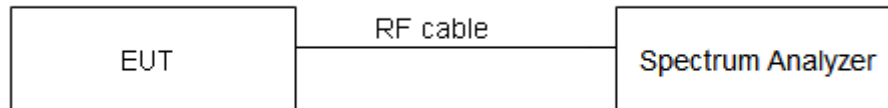

Limits

Rule Part 15.247 (b) (3) specifies that " For systems using digital modulation in the 902–928 MHz, 2400–2483.5 MHz: 1 Watt."

Average Output Power	≤ 1W (30dBm)
----------------------	--------------

Measurement Uncertainty

The assessed measurement uncertainty to ensure 95% confidence level for the normal distribution is with the coverage factor $k = 2$, $U = 0.44$ dB.

Test Results

Single Antenna Power Index						
Packet Type	Antenna 1			Antenna 2		
	CH1	CH6	CH11	CH1	CH6	CH11
802.11b	1.5	13	15	1.5	14	15
802.11g	1.5	13	15.5	1.5	15	15.5
MIMO Antenna Power Index						
Packet Type	Antenna 1			Antenna 2		
	CH1	CH6	CH11	CH1	CH6	CH11
802.11n HT20	0	14	9	0	16	9
Packet Type	CH3	CH6	CH9	CH3	CH6	CH9
802.11n HT40	0	9	8	0	9	8

Band	T _{on} (ms)	T _(on+off) (ms)	Duty cycle	Duty cycle correction Factor(dB)
802.11b	8.18	8.24	0.99	N/A
802.11g	1.36	1.41	0.97	0.15
802.11n HT20	1.27	1.32	0.96	0.16
802.11n HT40	0.63	0.67	0.95	0.24

Note: when Duty cycle>0.98, Duty cycle correction Factor not required.

SISO Antenna 1

Network Standards	Carrier frequency (MHz)	Read Value (dBm)	Average Output Power (dBm)	Limit (dBm)	Conclusion
802.11b	2412	17.83	17.83	30	PASS
	2437	16.54	16.54	30	PASS
	2462	16.33	16.33	30	PASS
802.11g	2412	17.69	17.84	30	PASS
	2437	16.20	16.35	30	PASS
	2462	16.74	16.89	30	PASS

Note: Output Power=Read Value+Duty cycle correction factor

SISO Antenna 2

Network Standards	Carrier frequency (MHz)	Read Value (dBm)	Average Output Power (dBm)	Limit (dBm)	Conclusion
802.11b	2412	19.60	19.60	30	PASS
	2437	16.56	16.56	30	PASS
	2462	18.70	18.70	30	PASS
802.11g	2412	19.17	19.32	30	PASS
	2437	16.43	16.58	30	PASS
	2462	18.15	18.30	30	PASS

Note: Output Power=Read Value+Duty cycle correction factor

MIMO

Network Standards	Carrier frequency (MHz)	Antenna 1		Antenna 2		Total Power	Limit (dBm)	Conclusion
		Read Value (dBm)	Average Output Power (dBm)	Read Value (dBm)	Average Output Power (dBm)	Average Output Power (dBm)		
802.11n HT20	2412	16.18	16.34	17.77	17.93	20.22	30	PASS
	2437	16.65	16.81	16.64	16.80	19.82	30	PASS
	2462	10.73	10.89	13.75	13.91	15.67	30	PASS
802.11n HT40	2422	17.62	17.86	17.76	18.00	20.94	30	PASS
	2437	16.25	16.49	16.56	16.80	19.66	30	PASS
	2452	10.05	10.29	12.68	12.92	14.81	30	PASS

Note: 1. Output Power=Read Value+Duty cycle correction factor
 2. For Total Power, according to KDB 662911 D01 Multiple Transmitter Output v02r01 1),
 The Total Power = $10\log(10^{(\text{Power antenna1 in dBm}/10)} + 10^{(\text{Power antenna2 in dBm}/10)})$.
 3. The manufacturer declared the transmitter output signals is CDD mode. And $N_{SS}=1$. According to KDB 662911 D01 Multiple Transmitter Output v02r01 2)f)(i): If all antennas have the same gain,
 Directional gain = $G_{ANT} + \text{Array Gain}$,
 For power measurements on IEEE 802.11 devices,
 Array Gain = 0 dB (i.e., no array gain) for $N_{ANT} \leq 4$;
 Array Gain = 0 dB (i.e., no array gain) for channel widths ≥ 40 MHz for any N_{ANT} ;
 Array Gain = $5 \log(N_{ANT}/N_{SS})$ dB or 3 dB, whichever is less, for 20-MHz channel widths with $N_{ANT} \geq 5$.
 So directional gain = $G_{ANT} + \text{Array Gain} = 3 + 0 = 3\text{dBi} < 6\text{dBi}$. So the power limit is 30dBm

5.2. 6dB Bandwidth

Ambient condition

Temperature	Relative humidity	Pressure
23°C ~25°C	45%~50%	101.5kPa

Method of Measurement

The EUT was connected to the spectrum analyzer through an external attenuator (20dB) and a known loss cable. RBW is set to 100 kHz; VBW is set to 300 kHz on spectrum analyzer.

Test Setup

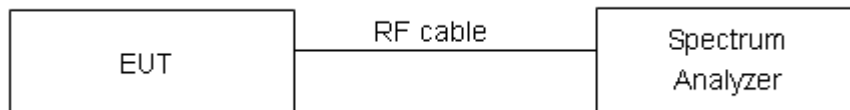

Limits

Rule Part 15.247 (a) (2) specifies that “Systems using digital modulation techniques may operate in the 902–928 MHz, 2400–2483.5 MHz bands. The minimum 6 dB bandwidth shall be at least 500 kHz.”

minimum 6 dB bandwidth	≥ 500 kHz
------------------------	-----------

Measurement Uncertainty

The assessed measurement uncertainty to ensure 95% confidence level for the normal distribution is with the coverage factor $k = 2$, $U = 936$ Hz.

**Test Results:****SISO Antenna 2**

Network Standards	Carrier frequency (MHz)	99% bandwidth (MHz)	Minimum 6 dB bandwidth (MHz)	Limit (kHz)	Conclusion
802.11b	2412	14.840	10.09	500	PASS
	2437	14.485	10.08	500	PASS
	2462	15.168	10.12	500	PASS
802.11g	2412	20.681	15.77	500	PASS
	2437	18.153	15.76	500	PASS
	2462	16.820	16.37	500	PASS

MIMO

Network Standards	Carrier frequency (MHz)	99% bandwidth (MHz)	Minimum 6 dB bandwidth (MHz)	Limit (kHz)	Conclusion
802.11n HT20	2412	19.949	16.34	500	PASS
	2437	18.632	16.37	500	PASS
	2462	17.694	16.69	500	PASS
802.11n HT40	2422	38.677	35.71	500	PASS
	2437	36.777	35.73	500	PASS
	2452	36.397	36.13	500	PASS



SISO Antenna 2

802.11b, Carrier frequency (MHz): 2412



802.11g, Carrier frequency (MHz): 2412



802.11b, Carrier frequency (MHz): 2437



802.11g, Carrier frequency (MHz): 2437



802.11b, Carrier frequency (MHz): 2462



802.11g, Carrier frequency (MHz): 2462



MIMO

802.11n(HT20), Carrier frequency (MHz): 2412

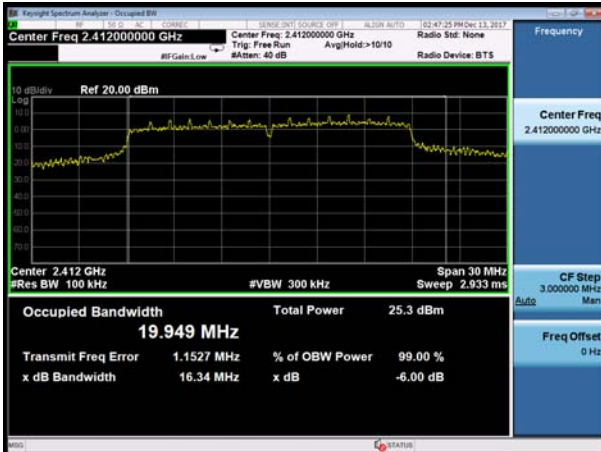

802.11n(HT40), Carrier frequency (MHz): 2422



802.11n(HT20), Carrier frequency (MHz): 2437



802.11n(HT40), Carrier frequency (MHz): 2437

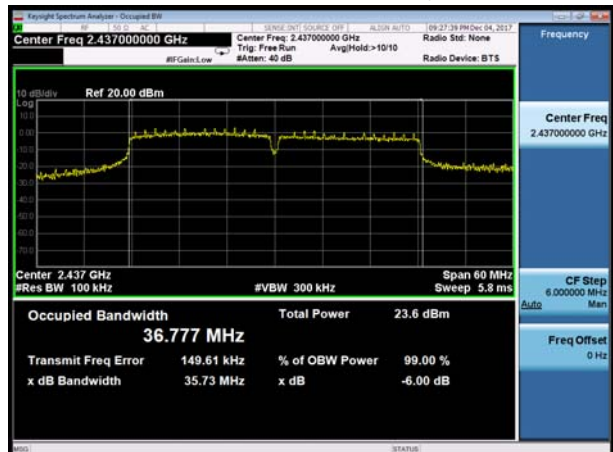

802.11n(HT20), Carrier frequency (MHz): 2462



802.11n(HT40), Carrier frequency (MHz): 2452



5.3. Power Spectral Density

Ambient condition

Temperature	Relative humidity	Pressure
23°C ~25°C	45%~50%	101.5kPa

Method of Measurement

The EUT was connected to the spectrum analyzer through an external attenuator (20dB) and a known loss cable.

RBW is set to 3 kHz and VBW is set to 10 kHz for Wi-Fi 2.4G on spectrum analyzer.

Set the span to 1.5 times the DTS channel bandwidth. Sweep time = auto couple. Trace mode = max hold. The Average power spectral density is recorded.

The conducted Power is measured at each antenna port. The measured results at the various antenna ports are then summed mathematically.

Test setup

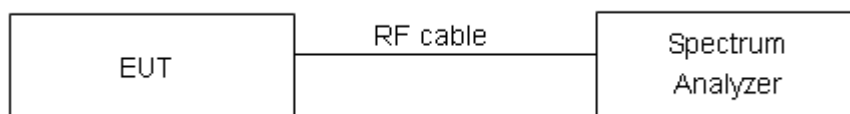

Limits

Rule Part 15.247(e) specifies that” For digitally modulated systems, the power spectral density conducted from the intentional radiator to the antenna shall not be greater than 8 dBm in any 3 kHz band during any time interval of continuous transmission. ”

Limits	≤ 8 dBm / 3kHz
--------	----------------

Measurement Uncertainty

The assessed measurement uncertainty to ensure 95% confidence level for the normal distribution is with the coverage factor $k = 2$, $U = 0.75\text{dB}$.

**Test Results:****SISO Antenna 1**

Network Standards	Channel Number	Read Value (dBm)	Power Spectral Density (dBm / 3kHz)	Limit (dBm / 3kHz)	Conclusion
802.11b	1	-11.07	-11.07	8	PASS
	6	-16.38	-16.38	8	PASS
	11	-18.98	-18.98	8	PASS
802.11g	1	-16.32	-16.16	8	PASS
	6	-18.21	-18.06	8	PASS
	11	-19.73	-19.58	8	PASS

SISO Antenna 2

Network Standards	Channel Number	Read Value (dBm)	Power Spectral Density (dBm / 3kHz)	Limit (dBm / 3kHz)	Conclusion
802.11b	1	-13.66	-13.66	8	PASS
	6	-16.87	-16.87	8	PASS
	11	-14.74	-14.74	8	PASS
802.11g	1	-15.25	-15.10	8	PASS
	6	-18.02	-17.87	8	PASS
	11	-17.71	-17.56	8	PASS

MIMO

Network Standards	Channel Number	Antenna 1		Antenna 2		Total PSD	Limit (dBm / 3kHz)	Conclusion
		Read Value (dBm / 3kHz)	Power Spectral Density (dBm / 3kHz)	Read Value (dBm / 3kHz)	Power Spectral Density (dBm / 3kHz)	Power Spectral Density (dBm / 3kHz)		
802.11n HT20	1	-18.40	-18.24	-16.99	-16.83	-14.47	7.99	PASS
	6	-18.11	-17.95	-18.05	-17.89	-14.91	7.99	PASS
	11	-27.11	-26.95	-23.35	-23.19	-21.66	7.99	PASS
802.11n HT40	3	-20.65	-20.41	-20.14	-19.90	-17.14	7.99	PASS
	6	-20.61	-20.37	-20.72	-20.48	-17.41	7.99	PASS
	9	-27.55	-27.31	-25.47	-25.23	-23.14	7.99	PASS

Note: 1. Power Spectral Density =Read Value+Duty cycle correction factor
 2. For Total PSD, according to KDB 662911 D01 Multiple Transmitter Output v02r01 2)a),the power spectral density= $10\log(10^{(PSD\ antenna1\ in\ dBm/10)}+10^{(PSD\ antenna2\ in\ dBm/10)})$
 3. The manufacturer declared the transmitter output signals is CDD mode. And $N_{ss}=1$. According to KDB 662911 D01 Multiple Transmitter Output v02r01 2)f)(i): If all antennas have the same gain, Directional gain = $G_{ANT} + \text{Array Gain}$, For power spectral density (PSD) measurements on all devices, Array Gain = $10\log(N_{ANT}/N_{SS})\text{ dB}=3.01$.
 So directional gain = $G_{ANT} + \text{Array Gain} = 3.0+3.01=6.01\text{dBi} > 6\text{dBi}$. So the power limit is $8 - (6.01-6) = 7.99\text{dBm}$.



SISO Antenna 1

802.11b, Channel No.: 1



802.11g, Channel No.: 1

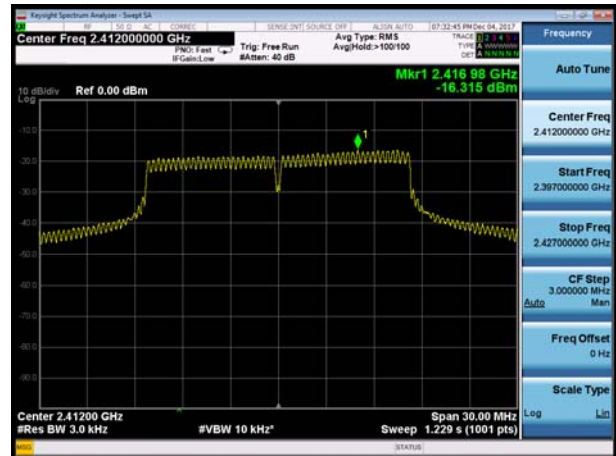

802.11b, Channel No.: 6



802.11g, Channel No.: 6



802.11b, Channel No.: 11



802.11g, Channel No.: 11

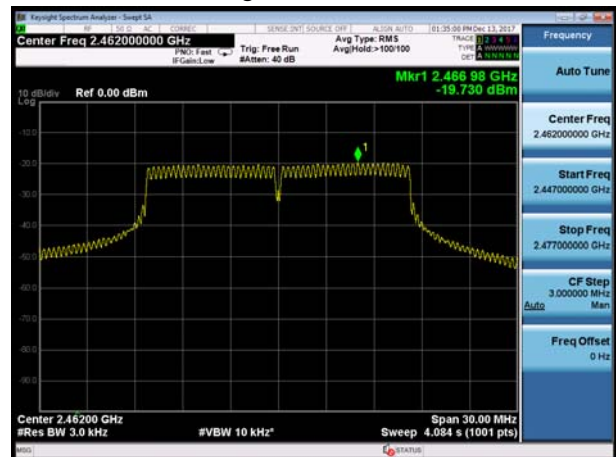



SISO Antenna 2

802.11b, Channel No.: 1



802.11g, Channel No.: 1



802.11b, Channel No.: 6



802.11g, Channel No.: 6

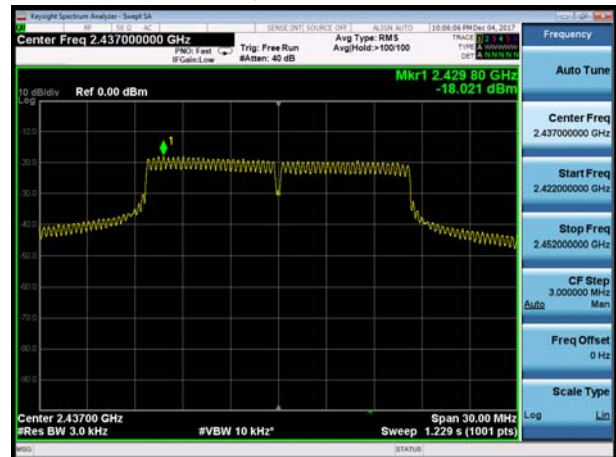

802.11b, Channel No.: 11



802.11g, Channel No.: 11





MIMO Antenna 1

802.11n(HT20), Channel No. 1



802.11n(HT40), Channel No. 3



802.11n(HT20), Channel No. 6

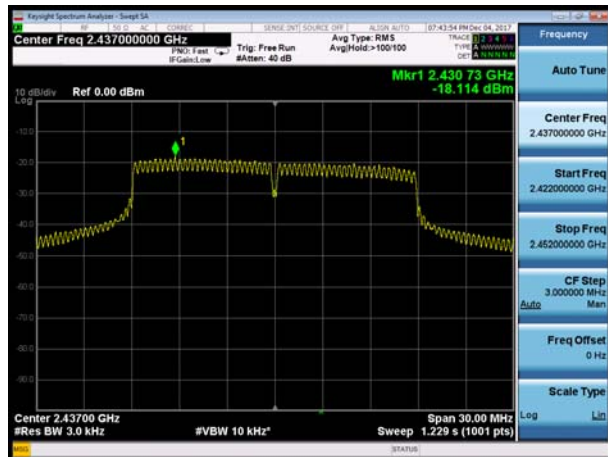

802.11n(HT40), Channel No. 6

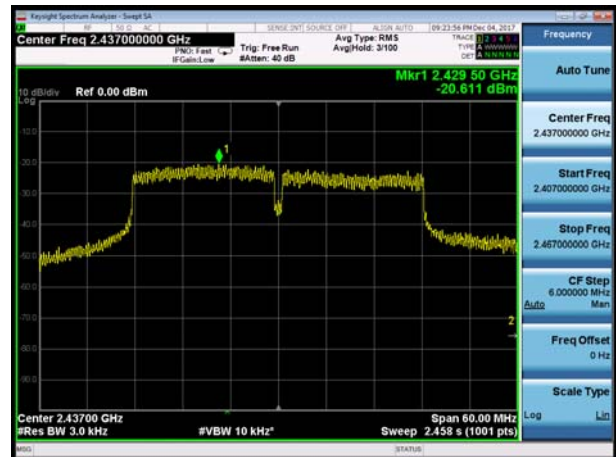

802.11n(HT20), Channel No. 11

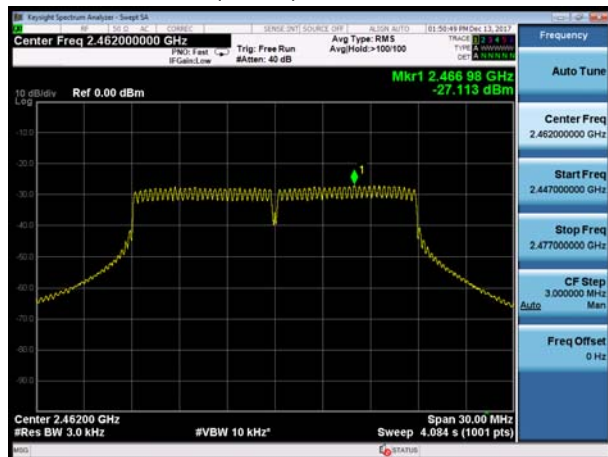

802.11n(HT40), Channel No. 9



MIMO Antenna 2

802.11n(HT20), Channel No. 1



802.11n(HT40), Channel No. 3

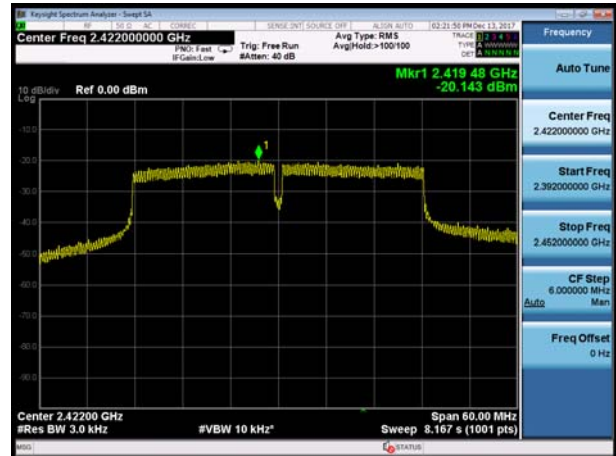

802.11n(HT20), Channel No. 6

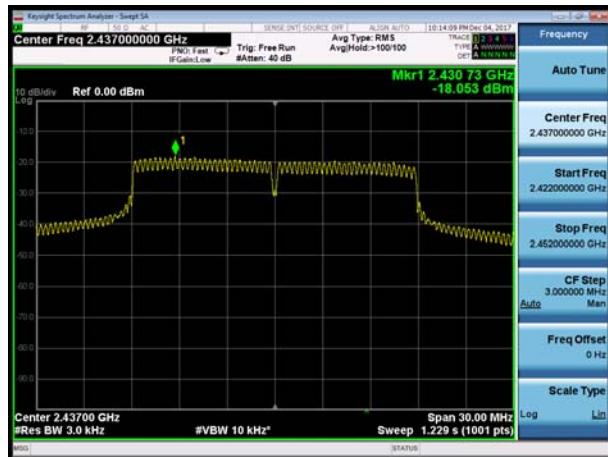

802.11n(HT40), Channel No. 6



802.11n(HT20), Channel No. 11

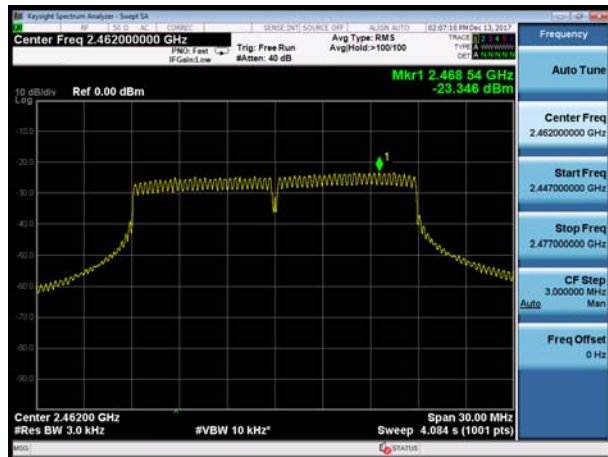

802.11n(HT40), Channel No. 9



5.4. Spurious RF Conducted Emissions

Ambient condition

Temperature	Relative humidity	Pressure
23°C ~25°C	45%~50%	101.5kPa

Method of Measurement

The EUT was connected to the spectrum analyzer with a known loss. The spectrum analyzer scans from 30MHz to the 10th harmonic of the carrier. The peak detector is used. Set RBW to100kHz and VBW to 300 kHz, Sweep is set to ATUO.

The test is in transmitting mode.

Test setup



Limits

Rule Part 15.247(d) pacifies that “In any 100 kHz bandwidth outside the frequency band in which the spread spectrum intentional radiator is operating, the radio frequency power that is produced by the intentional radiator shall be at least 20 dB below that in the 100 kHz bandwidth within the band that contains the highest level of the desired power.”

Network Standards	Carrier frequency (MHz)	Reference value (dBm)	Limit
802.11b	2412	10.670	-9.330
	2437	10.575	-9.425
	2462	9.455	-10.545
802.11g	2412	14.900	-5.100
	2437	13.383	-6.617
	2462	11.700	-8.300
802.11n HT20	2412	13.040	-6.960
	2437	13.20	-6.800
	2462	4.326	-15.674
802.11n HT40	2422	7.170	-12.830
	2437	6.820	-13.180
	2452	2.000	-18.000

**Measurement Uncertainty**

The assessed measurement uncertainty to ensure 95% confidence level for the normal distribution is with the coverage factor $k = 1.96$.

Frequency	Uncertainty
100kHz-2GHz	0.684 dB
2GHz-26GHz	1.407 dB



Test Results:

SISO Antenna 2

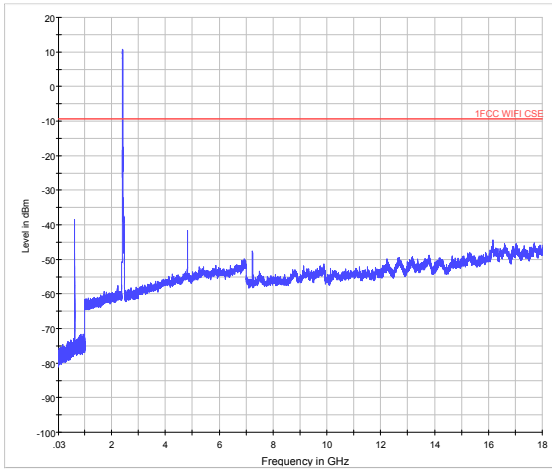

802.11b CH1 0.3GHz to 18GHz

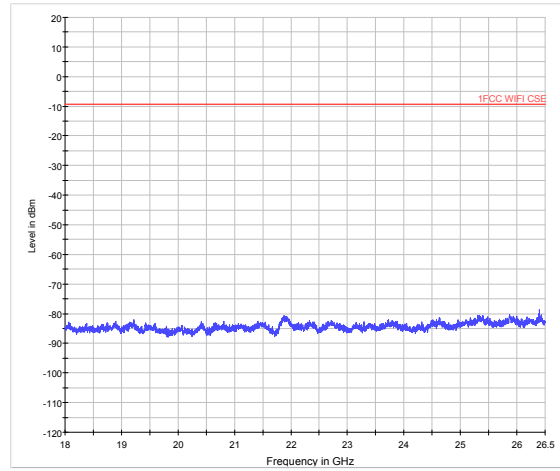

802.11b CH1 18GHz to 26.5GHz

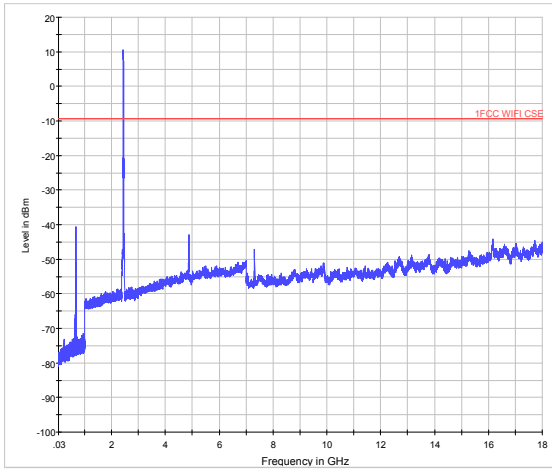

802.11b CH6 0.3GHz to 18GHz

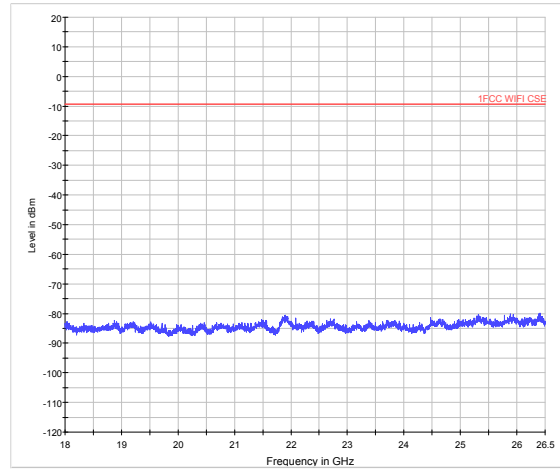

802.11b CH6 18GHz to 26.5GHz

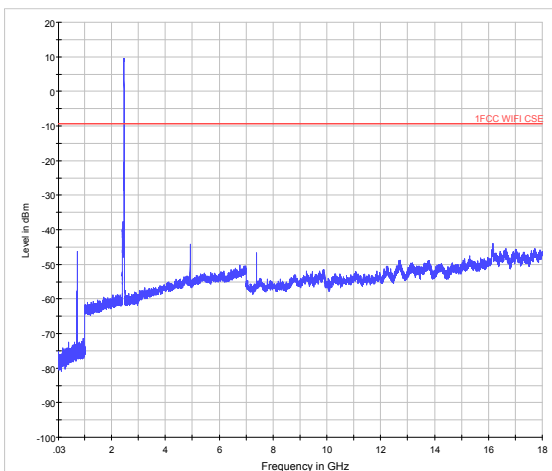

802.11b CH11 0.3GHz to 18GHz

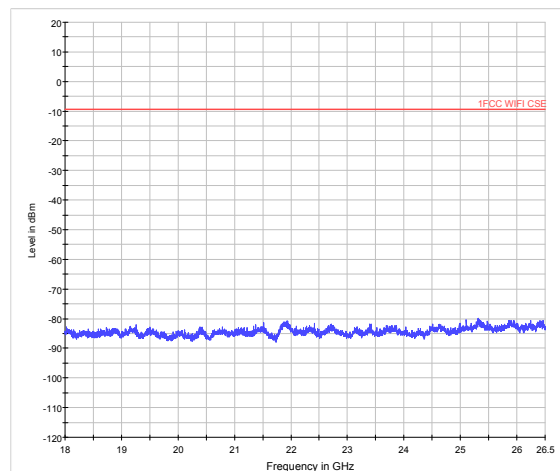

802.11b CH11 18GHz to 26.5GHz

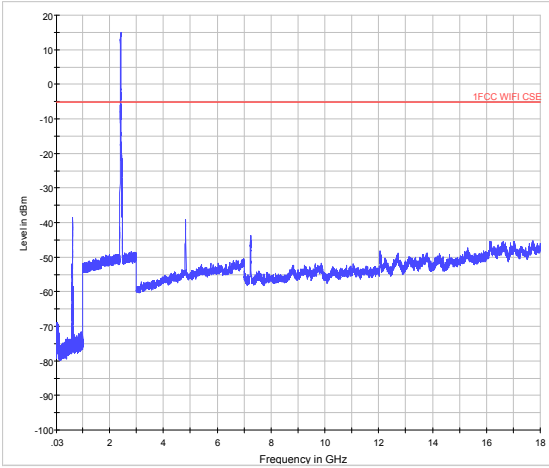

802.11g CH1 0.3GHz to 18GHz

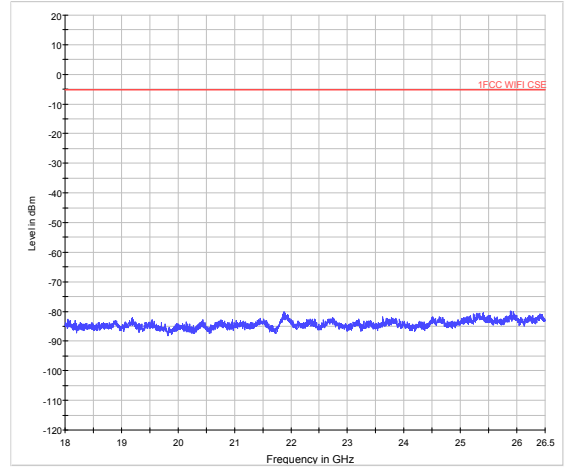

802.11g CH1 18GHz to 26.5GHz

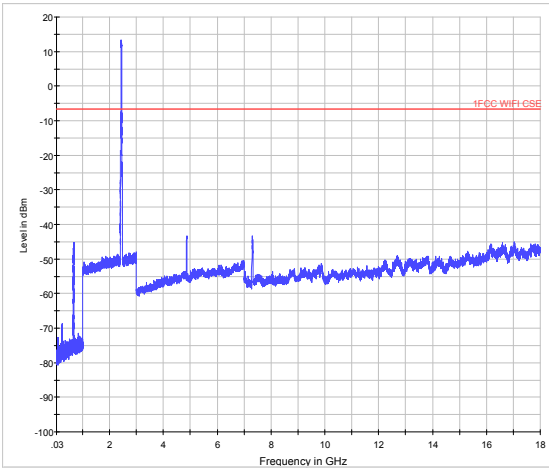

802.11g CH6 0.3GHz to 18GHz

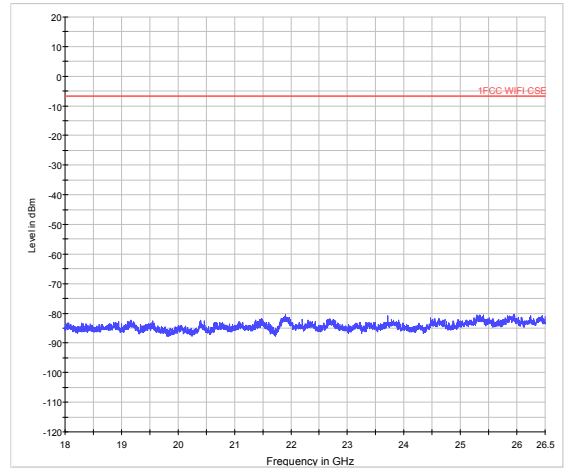

802.11g CH6 18GHz to 26.5GHz

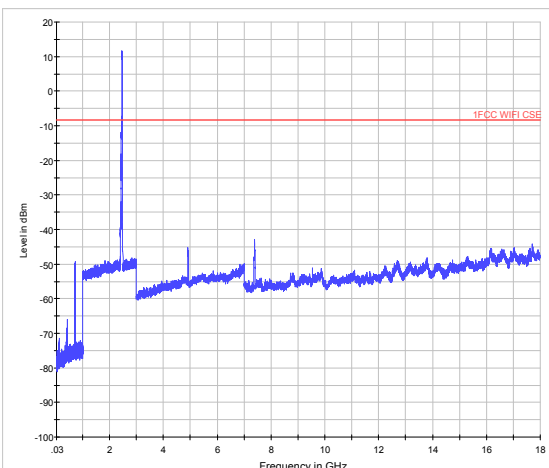

802.11g CH11 0.3GHz to 18GHz

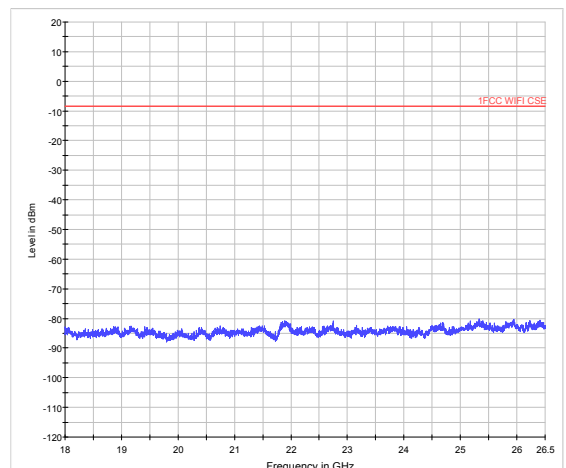

802.11g CH11 18GHz to 26.5GHz



MIMO

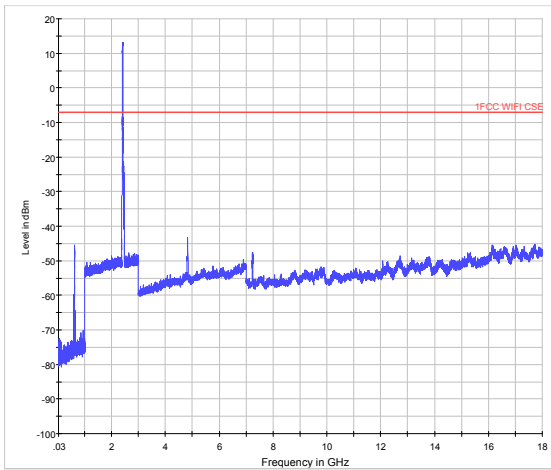

802.11n (HT20) CH1 0.3GHz to 18GHz

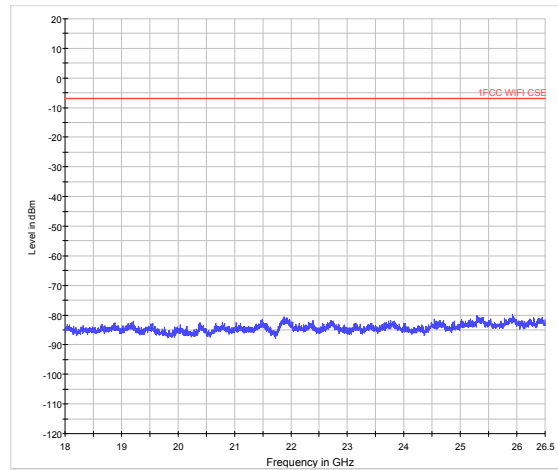

802.11n (HT20) CH1 18GHz to 26.5GHz

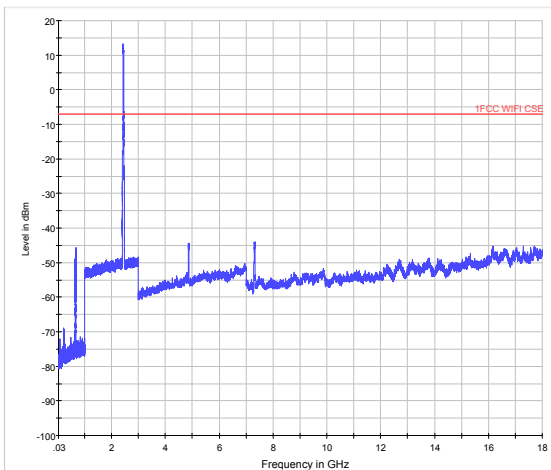

802.11n (HT20) CH6 0.3GHz to 18GHz

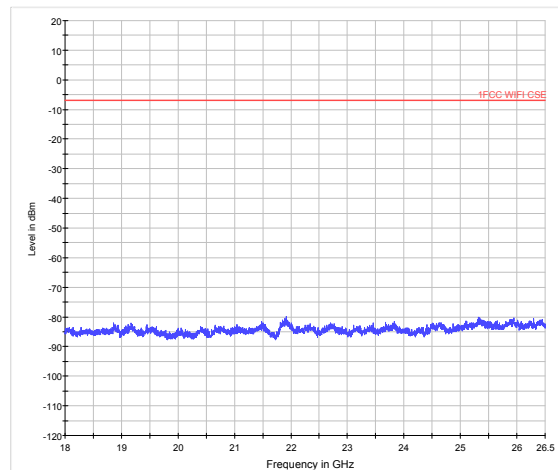

802.11n (HT20) CH6 18GHz to 26.5GHz

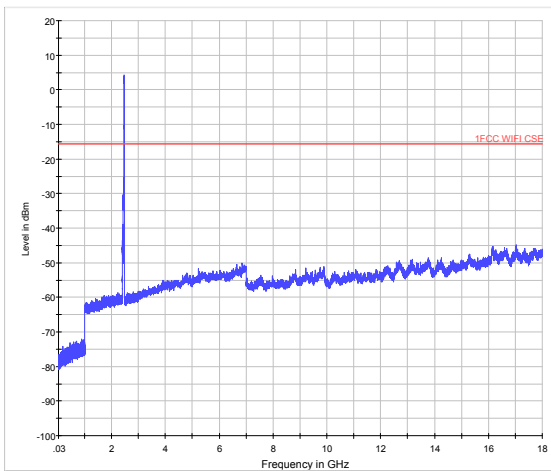

802.11n (HT20) CH11 0.3GHz to 18GHz

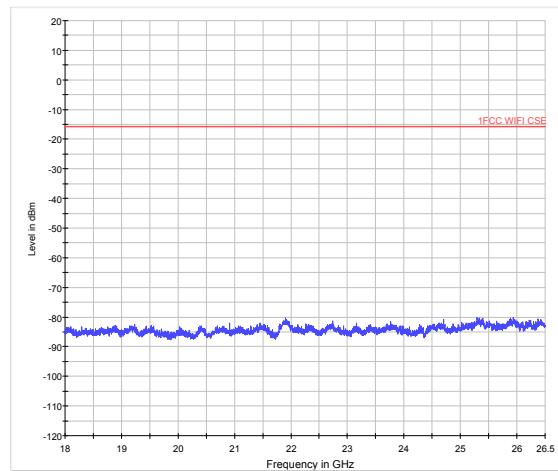

802.11n (HT20) CH11 18GHz to 26.5GHz

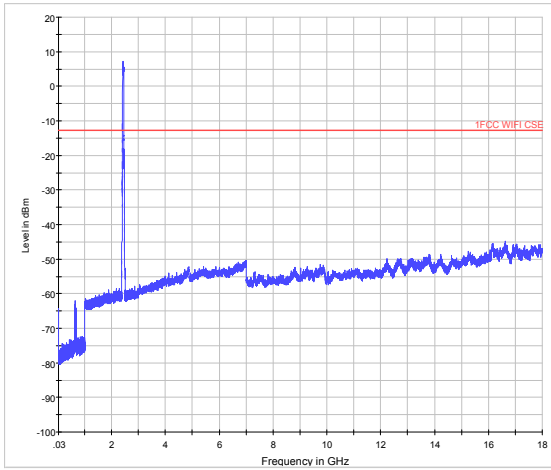

802.11n (HT40) CH3 0.3GHz to 18GHz

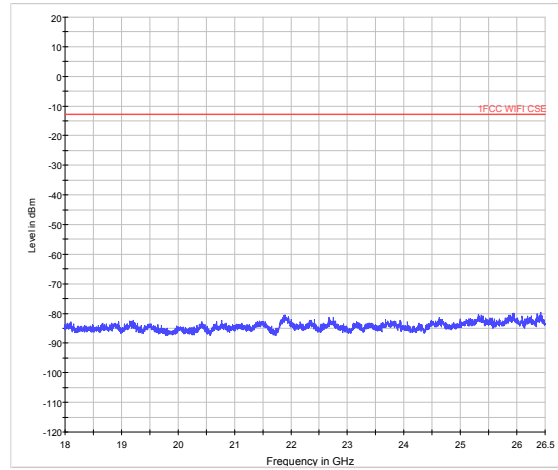

802.11n (HT40) CH3 18GHz to 26.5GHz

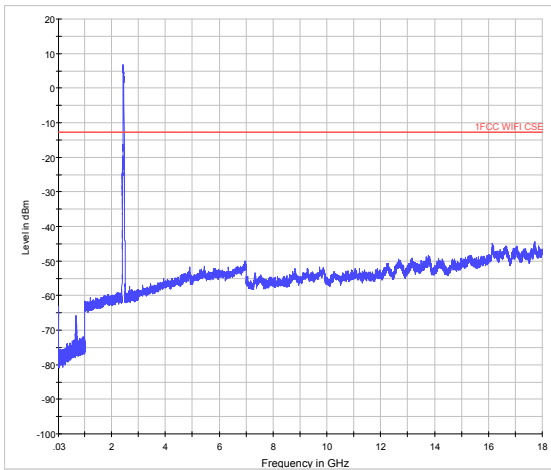

802.11n (HT40) CH6 0.3GHz to 18GHz

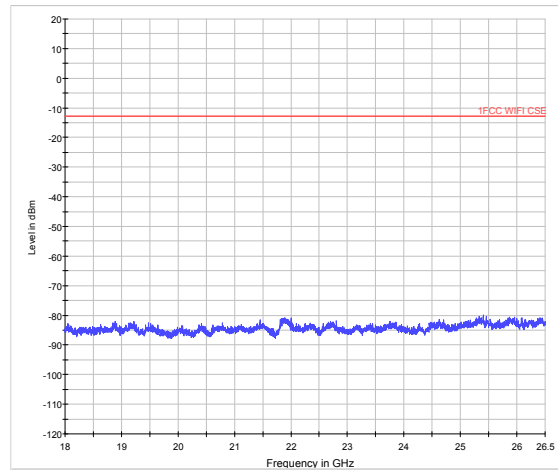

802.11n (HT40) CH6 18GHz to 26.5GHz

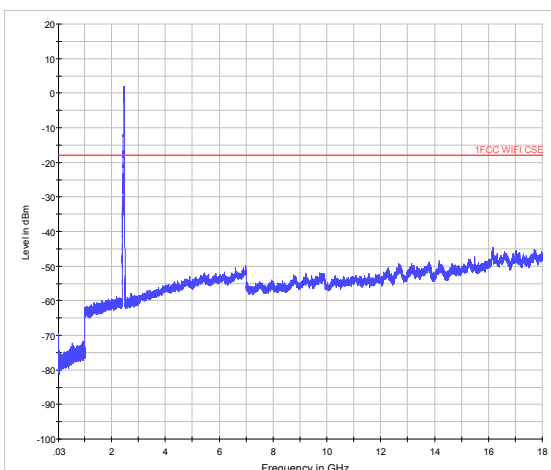

802.11n (HT40) CH9 0.3GHz to 18GHz

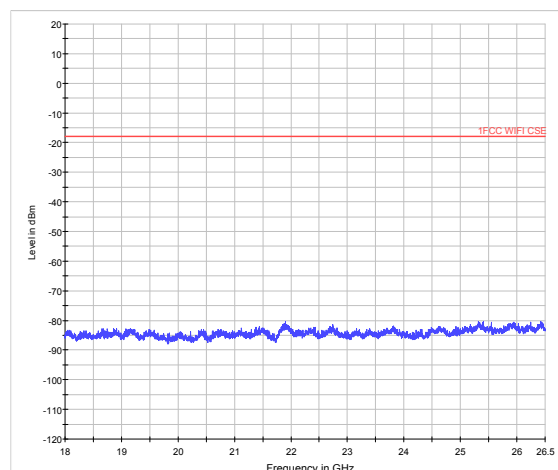

802.11n (HT40) CH9 18GHz to 26.5GHz

5.5. Radiated Emissions in the Restricted Band

Ambient condition

Temperature	Relative humidity	Pressure
23°C ~25°C	45%~50%	101.5kPa

Method of Measurement

The Equipment Under Test (EUT) was set up on a non-conductive table in the semi-anechoic chamber. The test was performed at the distance of 3 m between the EUT and the receiving antenna. The turntable shall be rotated from 0 to 360 degrees for detecting the maximum of radiated spurious signal level. The measurements shall be repeated with orthogonal polarization of the test antenna. The data of cable loss and antenna factor has been calibrated in full testing frequency range before the testing. Sweep the Restricted Band and the emissions less than 20 dB below the permissible value are reported.

This method refer to KDB 558074.

The procedure for peak unwanted emissions measurements above 1000 MHz is as follows:

I) Peak emission levels are measured by setting the instrument as follows:

- 1) RBW = 1 MHz.
- 2) VBW $\geq [3 \times \text{RBW}]$
- 3) Detector = peak.
- 4) Sweep time = auto.
- 5) Trace mode = max hold.
- 6) Allow sweeps to continue until the trace stabilizes. Note that if the transmission is not continuous, then the time required for the trace to stabilize will increase by a factor of approximately $1 / D$, where D is the duty cycle.

II) Average emission levels are measured by setting the instrument as follows:

- a) RBW = 1 MHz.
- b) VBW $\geq [3 \times \text{RBW}]$.
- c) Detector = RMS (power averaging), if $[\text{span} / (\# \text{ of points in sweep})] \leq \text{RBW} / 2$. Satisfying this condition can require increasing the number of points in the sweep or reducing the span. If the condition is not satisfied, then the detector mode shall be set to peak.
- d) Averaging type = power (i.e., rms) (As an alternative, the detector and averaging type may be set for linear voltage averaging. Some instruments require linear display mode to use linear voltage averaging. Log or dB averaging shall not be used.)
- e) Sweep time = auto.
- f) Perform a trace average of at least 100 traces if the transmission is continuous. If the transmission is not continuous, then the number of traces shall be increased by a factor of $1 / D$, where D is the duty cycle. For example, with 50% duty cycle, at least 200 traces shall be averaged. (If a specific emission is demonstrated to be continuous—i.e., 100% duty cycle—then rather than turning ON and OFF with the transmit cycle, at least 100 traces shall be averaged.)
- g) If tests are performed with the EUT transmitting at a duty cycle less than 98%, then a correction

factor shall be added to the measurement results prior to comparing with the emission limit, to compute the emission level that would have been measured had the test been performed at 100% duty cycle. The correction factor is computed as follows:

- 1) If power averaging (rms) mode was used in the preceding step e), then the correction factor is $[10 \log (1 / D)]$, where D is the duty cycle. For example, if the transmit duty cycle was 50%, then 3 dB shall be added to the measured emission levels.
- 2) If linear voltage averaging mode was used in the preceding step e), then the correction factor is $[20 \log (1 / D)]$, where D is the duty cycle. For example, if the transmit duty cycle was 50%, then 6 dB shall be added to the measured emission levels.
- 3) If a specific emission is demonstrated to be continuous (100% duty cycle) rather than turning ON and OFF with the transmit cycle, then no duty cycle correction is required for that emission.

The field strength of spurious emission was measured in the following position: EUT stand-up position (Z axis), lie-down position (X, Y axis). The worst emission was found in stand-up position (Z axis) and the antenna is vertical.

The test is in transmitting mode.

Test setup

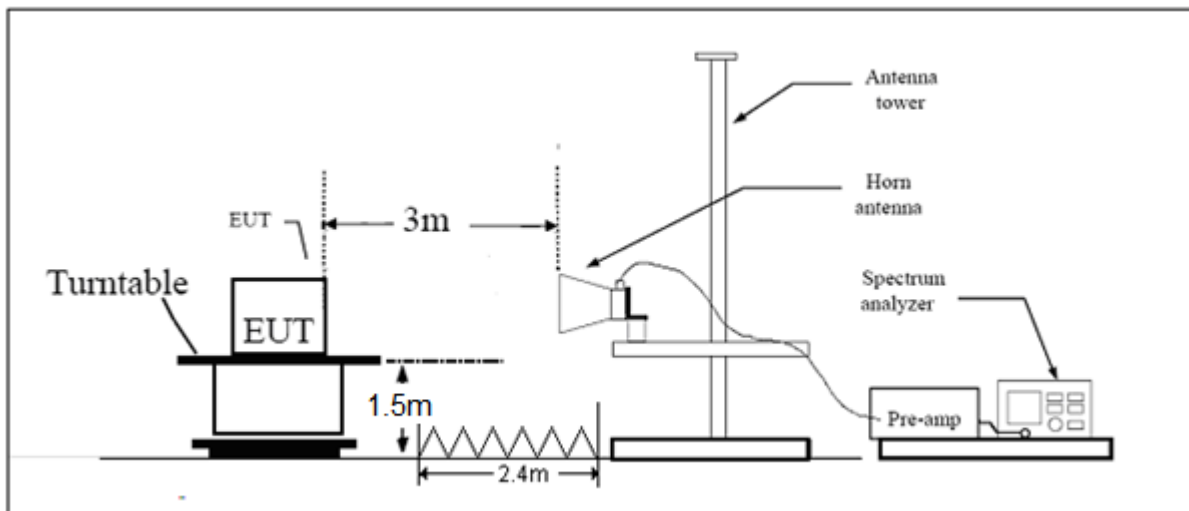

Note: Area side: 2.4mX3.6m

Limits

Spurious Radiated Emissions are permitted in any of the frequency bands listed below:



MHz	MHz	MHz	GHz
0.090 - 0.110	16.42 - 16.423	399.9 - 410	4.5 - 5.15
¹ 0.495 - 0.505	16.69475 - 16.69525	608 - 614	5.35 - 5.46
2.1735 - 2.1905	16.80425 - 16.80475	960 - 1240	7.25 - 7.75
4.125 - 4.128	25.5 - 25.67	1300 - 1427	8.025 - 8.5
4.17725 - 4.17775	37.5 - 38.25	1435 - 1626.5	9.0 - 9.2
4.20725 - 4.20775	73 - 74.6	1645.5 - 1646.5	9.3 - 9.5
6.215 - 6.218	74.8 - 75.2	1660 - 1710	10.6 - 12.7
6.26775 - 6.26825	108 - 121.94	1718.8 - 1722.2	13.25 - 13.4
6.31175 - 6.31225	123 - 138	2200 - 2300	14.47 - 14.5
8.291 - 8.294	149.9 - 150.05	2310 - 2390	15.35 - 16.2
8.362 - 8.366	156.52475 - 156.52525	2483.5 - 2500	17.7 - 21.4
8.37625 - 8.38675	156.7 - 156.9	2690 - 2900	22.01 - 23.12
8.41425 - 8.41475	162.0125 - 167.17	3260 - 3267	23.6 - 24.0
12.29 - 12.293	167.72 - 173.2	3332 - 3339	31.2 - 31.8
12.51975 - 12.52025	240 - 285	3345.8 - 3358	36.43 - 36.5
12.57675 - 12.57725	322 - 335.4	3600 - 4400	(²)
13.36 - 13.41			

Limit in restricted band

Frequency of emission (MHz)	Field strength(uV/m)	Field strength(dBuV/m)
30-88	100	40
88-216	150	43.5
216-960	200	46
Above960	500	54

§15.35(b)

There is also a limit on the radio frequency emissions, as measured using instrumentation with a peak detector function, corresponding to 20 dB above the maximum permitted average limit.

Peak Limit=74 dBuV/m

Average Limit=54 dBuV/m

Measurement Uncertainty

The assessed measurement uncertainty to ensure 95% confidence level for the normal distribution is with the coverage factor $k = 1.96$, $U = 3.55$ dB.

**Test Results:****PASS**

The signal beyond the limit is carrier.

Band	T _{on} (ms)	T _(on+off) (ms)	Duty cycle	Duty cycle correction Factor(dB)
802.11b	8.18	8.24	0.99	N/A
802.11g	1.36	1.41	0.97	0.15
802.11n HT20	1.27	1.32	0.96	0.16
802.11n HT40	0.63	0.67	0.95	0.24

Note: when Duty cycle>0.98, Duty cycle correction Factor not required.

SISO Antenna 2**802.11b-Channel 1**

Frequency (MHz)	Peak (dBuV/m)	Average (dBuV/m)	Height (cm)	Polarization	Azimuth (deg)	Duty cycle correction Factor(dB)	conclusion value (dBuV/m)	Margin (dB)	Limit (dBuV/m)
2390	52.011	--	200.0	V	135	0	52.011	21.989	74
2390	--	41.187	200.0	V	135	0	41.187	12.813	54

802.11b-Channel 11

Frequency (MHz)	Peak (dBuV/m)	Average (dBuV/m)	Height (cm)	Polarization	Azimuth (deg)	Duty cycle correction Factor(dB)	conclusion value (dBuV/m)	Margin (dB)	Limit (dBuV/m)
2483.5	53.034	--	200.0	V	135	0	53.034	20.966	74
2483.5	--	43.154	200.0	V	135	0	43.154	10.846	54

802.11g-Channel 1

Frequency (MHz)	Peak (dBuV/m)	Average (dBuV/m)	Height (cm)	Polarization	Azimuth (deg)	Duty cycle correction Factor(dB)	conclusion value (dBuV/m)	Margin (dB)	Limit (dBuV/m)
2390	70.063	--	150	V	65	0.15	70.213	3.787	74
2390	--	50.480	150	V	65	0.15	50.63	3.37	54

802.11g-Channel 11

Frequency (MHz)	Peak (dBuV/m)	Average (dBuV/m)	Height (cm)	Polarization	Azimuth (deg)	Duty cycle correction Factor(dB)	conclusion value (dBuV/m)	Margin (dB)	Limit (dBuV/m)
2483.5	72.417	--	150	V	78	0.15	72.567	1.433	74
2483.5	--	52.822	150	V	78	0.15	52.972	1.028	54

**MIMO****802.11n HT20 -Channel 1**

Frequency (MHz)	Peak (dBuV/m)	Average (dBuV/m)	Height (cm)	Polarization	Azimuth (deg)	Duty cycle correction Factor(dB)	conclusion value (dBuV/m)	Margin (dB)	Limit (dBuV/m)
2390	71.365	--	200	V	90	0.16	71.525	2.475	74
2390	--	52.367	200	V	90	0.16	52.527	1.473	54

802.11n HT20-Channel 11

Frequency (MHz)	Peak (dBuV/m)	Average (dBuV/m)	Height (cm)	Polarization	Azimuth (deg)	Duty cycle correction Factor(dB)	conclusion value (dBuV/m)	Margin (dB)	Limit (dBuV/m)
2483.5	72.391	--	200	V	90	0.16	72.551	1.449	74
2483.5	--	53.651	200	V	90	0.16	53.811	0.189	54

802.11n HT40 -Channel 3

Frequency (MHz)	Peak (dBuV/m)	Average (dBuV/m)	Height (cm)	Polarization	Azimuth (deg)	Duty cycle correction Factor(dB)	conclusion value (dBuV/m)	Margin (dB)	Limit (dBuV/m)
2390	70.069	--	150	V	46	0.24	70.309	3.691	74
2390	--	53.628	150	V	46	0.24	53.868	0.132	54

802.11n HT40-Channel 9

Frequency (MHz)	Peak (dBuV/m)	Average (dBuV/m)	Height (cm)	Polarization	Azimuth (deg)	Duty cycle correction Factor(dB)	conclusion value (dBuV/m)	Margin (dB)	Limit (dBuV/m)
2483.5	73.484	--	150	V	46	0.24	73.724	0.276	74
2483.5	--	52.990	150	V	46	0.24	53.23	0.77	54

5.6. Radiates Emission

Ambient condition

Temperature	Relative humidity	Pressure
23°C ~25°C	45%~50%	102.5kPa

Method of Measurement

The test set-up was made in accordance to the general provisions of ANSI C63.10-2013. The Equipment Under Test (EUT) was set up on a non-conductive table in the semi-anechoic chamber. The test was performed at the distance of 3 m between the EUT and the receiving antenna. The radiated emissions measurements were made in a typical installation configuration.

Sweep the whole frequency band through the range from 9 kHz to the 10th harmonic of the carrier, and the emissions less than 20 dB below the permissible value are reported.

During the test, below 30MHz, the center of the loop shall be 1 meters; above 30MHz, the height of receive antenna shall be moved from 1 to 4 meters, and the antenna shall be performed under horizontal and vertical polarization. The turntable shall be rotated from 0 to 360 degrees for detecting the maximum of radiated spurious signal level. The measurements shall be repeated with orthogonal polarization of the test antenna. The data of cable loss and antenna factor has been calibrated in full testing frequency range before the testing.

Set the spectrum analyzer in the following:

Below 1GHz (detector: Peak and Quasi-Peak)

RBW=100 kHz / VBW=300 kHz / Sweep=AUTO

Above 1GHz (detector: Peak):

(a) PEAK: RBW=1MHz / VBW=3MHz / Sweep=AUTO

(b) AVERAGE: RBW=1MHz / VBW=3MHz / Sweep=AUTO

The radiated emission was measured in the following position: EUT stand-up position (Z axis), lie-down position (X, Y axis). The worst emission was found in lie-down position (X axis) and the worst case was recorded.

The test is in transmitting mode.

Test setup

9KHz ~ 30MHz

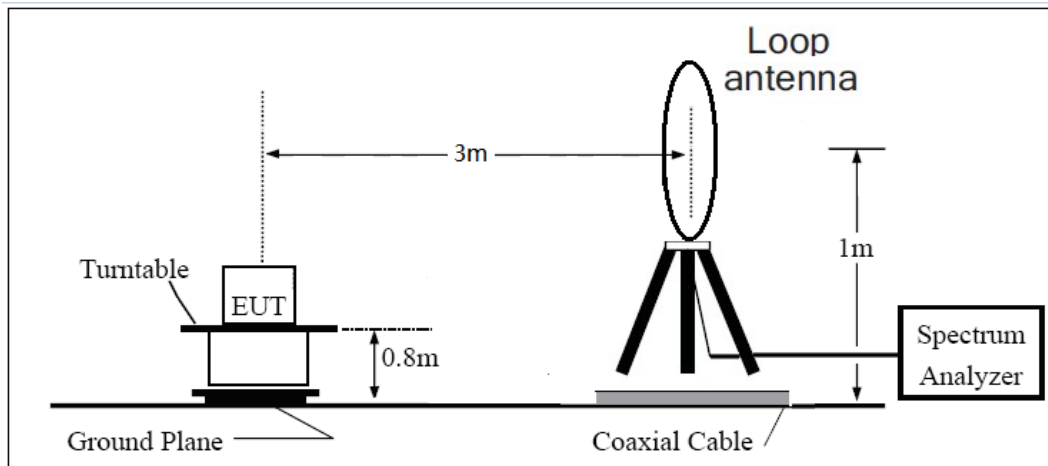

30MHz ~ 1GHz

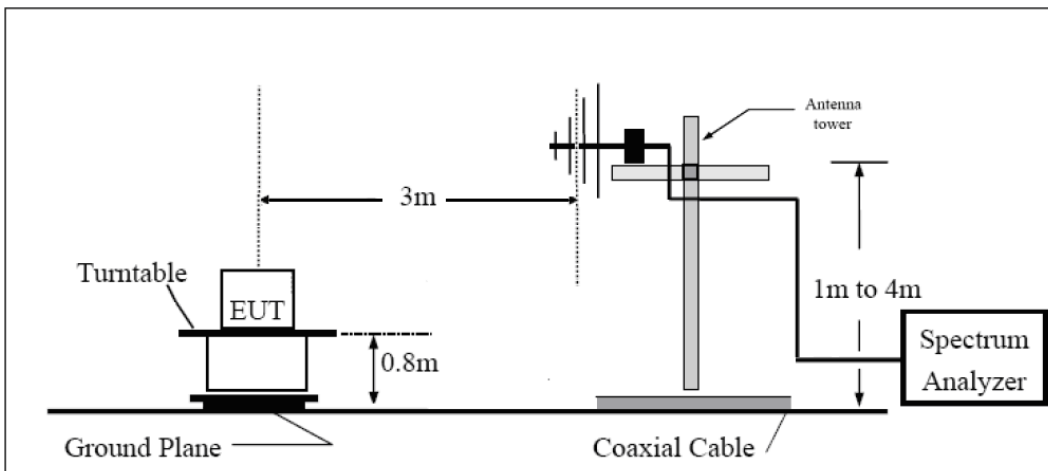

Above 1GHz

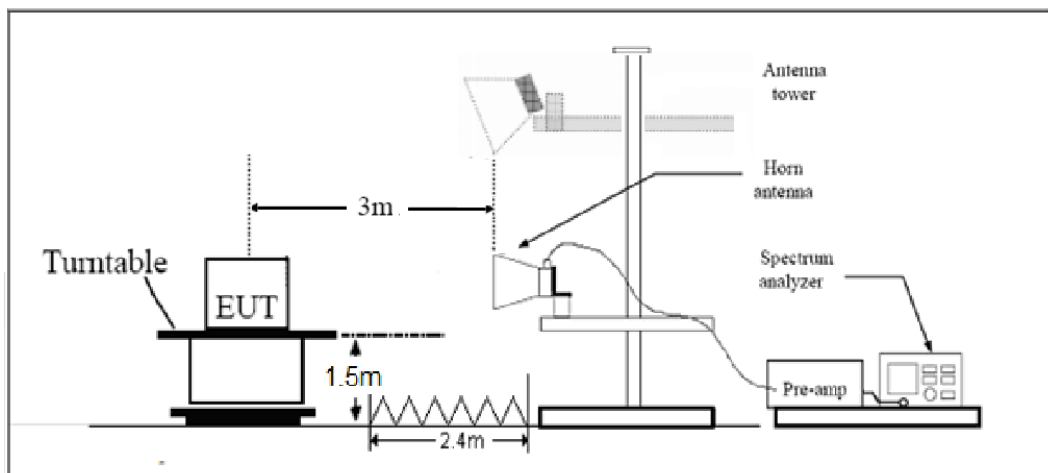

Note: Area side:2.4mX3.6m

Limits

Rule Part 15.247(d) specifies that “In addition, radiated emissions which fall in the restricted bands, as defined in § 15.205(a), must also comply with the radiated emission limits specified in § 15.209(a) (see § 15.205(c)).”

Limit in restricted band

Frequency of emission (MHz)	Field strength(uV/m)	Field strength(dBuV/m)
0.009–0.490	2400/F(kHz)	/
0.490–1.705	24000/F(kHz)	/
1.705–30.0	30	/
30-88	100	40
88-216	150	43.5
216-960	200	46
Above960	500	54

§15.35(b)

There is also a limit on the radio frequency emissions, as measured using instrumentation with a peak detector function, corresponding to 20 dB above the maximum permitted average limit.

Measurement Uncertainty

The assessed measurement uncertainty to ensure 95% confidence level for the normal distribution is with the coverage factor $k = 1.96$.

Frequency	Uncertainty
9KHz-30MHz	3.55 dB
30MHz-200MHz	4.19 dB
200MHz-1GHz	3.63 dB
Above 1GHz	3.68 dB

Test result

Sweep from 9 kHz to 30MHz, and the emissions more than 20 dB below the permissible value are not reported.

The following graphs display the maximum values of horizontal and vertical by software.

For above 1GHz, Blue trace uses the peak detection, Green trace uses the average detection.

During the test, the Radiates Emission from 30MHz to 1GHz was performed in all modes with all channels, SISO Antenna 2 802.11b, Channel 11 are selected as the worst condition. The test data of the worst-case condition was recorded in this report.

Continuous TX mode:

FCC RE 0.03-1GHz QP Class B

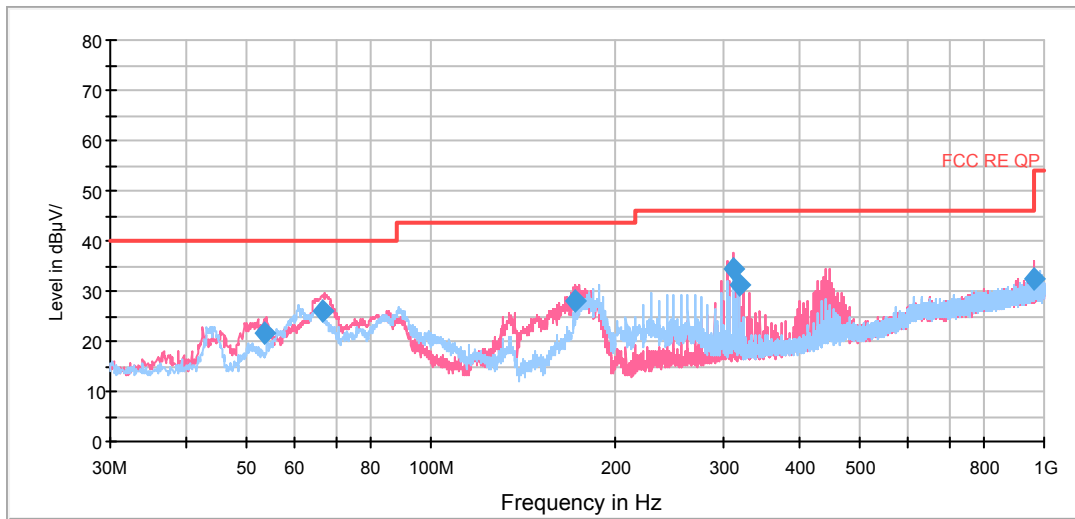

Radiates Emission from 30MHz to 1GHz

Frequency (MHz)	Quasi-Peak (dBuV/m)	Reading value (dBuV/m)	Height (cm)	Polarization	Azimuth (deg)	Correct Factor (dB)	Margin (dB)	Limit (dBuV/m)
53.577000	21.4	8.6	100.0	V	284.0	12.8	18.6	40.0
66.597000	25.9	15.8	114.0	V	206.0	10.1	14.1	40.0
171.997000	28.0	17.4	100.0	V	261.0	10.6	15.5	43.5
310.621000	34.2	18.6	175.0	V	0.0	15.6	11.8	46.0
317.451000	31.0	15.0	175.0	V	0.0	16.0	15.0	46.0
959.665000	32.3	4.9	202.0	V	72.0	27.4	13.7	46.0

- Remark:**
1. Quasi-Peak = Reading value + Correction factor
 2. Correction Factor = Antenna factor+ Insertion loss(cable loss+amplifier gain)
 3. Margin = Limit – Quasi-Peak

SISO Antenna 2

802.11b CH1

RE 1G-3GHz PK+AV

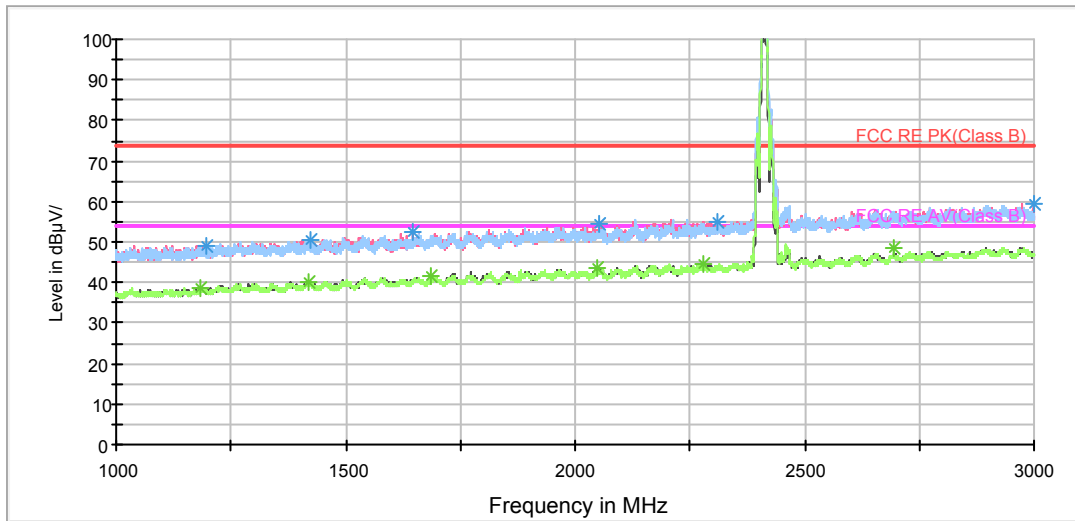

Note: The signal beyond the limit is carrier.
Radiates Emission from 1GHz to 3GHz

RE 3-18GHz PK+AV

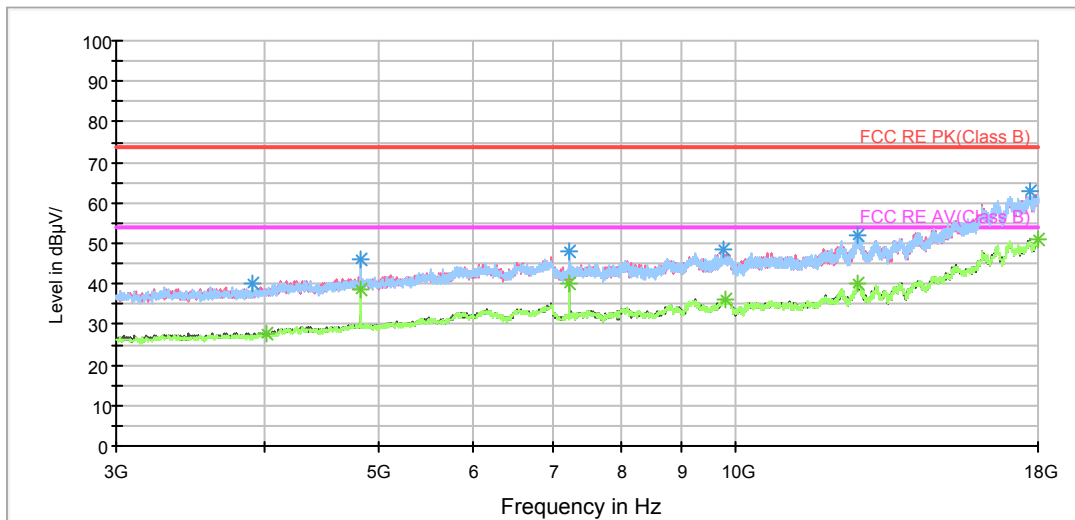

Radiates Emission from 3GHz to 18GHz

BELL_RE 18-26.5GHz PK+AV

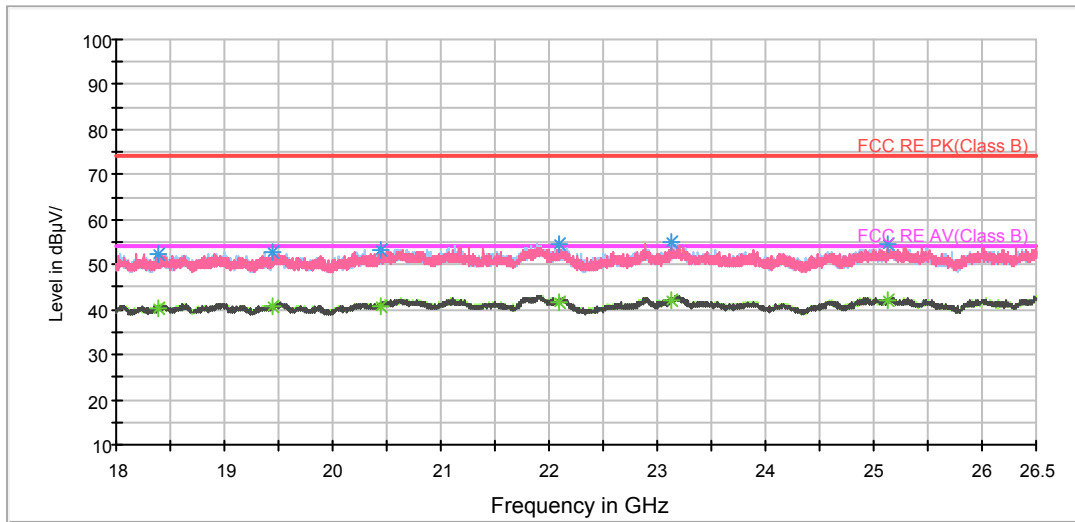

Radiates Emission from 18GHz to 26.5GHz

Frequency (MHz)	Peak (dBuV/m)	Height (cm)	Polarization	Azimuth (deg)	Reading value (dBuV/m)	Correct Factor (dB)	Margin (dB)	Limit (dBuV/m)
1195.750000	49.2	100.0	H	50.0	47.4	1.8	24.8	74
1425.000000	50.7	100.0	H	41.0	47.6	3.1	23.3	74
1644.500000	52.6	100.0	V	129.0	47.5	5.1	21.4	74
2054.250000	54.6	100.0	H	59.0	47.8	6.8	19.4	74
2309.500000	55.1	200.0	V	48.0	47.1	8.0	18.9	74
2998.000000	59.6	100.0	V	297.0	47.3	12.3	14.4	74

Remark: 1. Correction Factor = Antenna factor+ Insertion loss (cable loss + amplifier gain)

Frequency (MHz)	Average (dBuV/m)	Height (cm)	Polarization	Azimuth (deg)	Reading value (dBuV/m)	Correct Factor (dB)	Margin (dB)	Limit (dBuV/m)
1183.000000	38.8	200.0	V	95.0	36.8	2.0	15.2	54
1419.750000	40.1	200.0	V	11.0	37.0	3.1	13.9	54
1685.250000	41.7	100.0	V	261.0	36.7	5.0	12.3	54
2047.750000	43.8	200.0	V	114.0	37.0	6.8	10.2	54
2279.500000	44.4	100.0	V	297.0	35.7	8.7	9.6	54
2695.500000	48.6	100.0	H	41.0	38.6	10.0	5.4	54

Remark: 1. Correction Factor = Antenna factor+ Insertion loss (cable loss + amplifier gain)

802.11b CH6

RE 1G-3GHz PK+AV

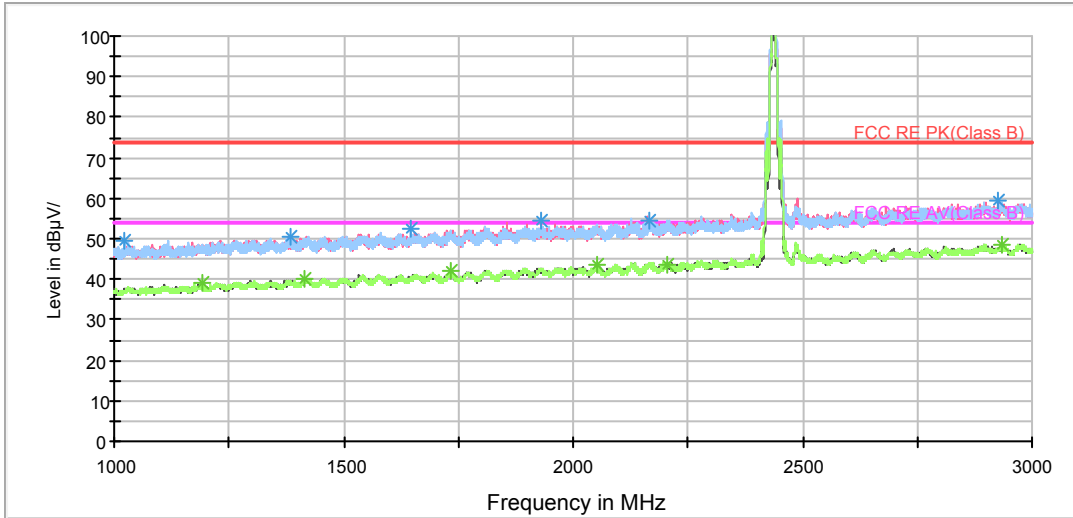

Note: The signal beyond the limit is carrier.
Radiates Emission from 1GHz to 3GHz

RE 3-18GHz PK+AV

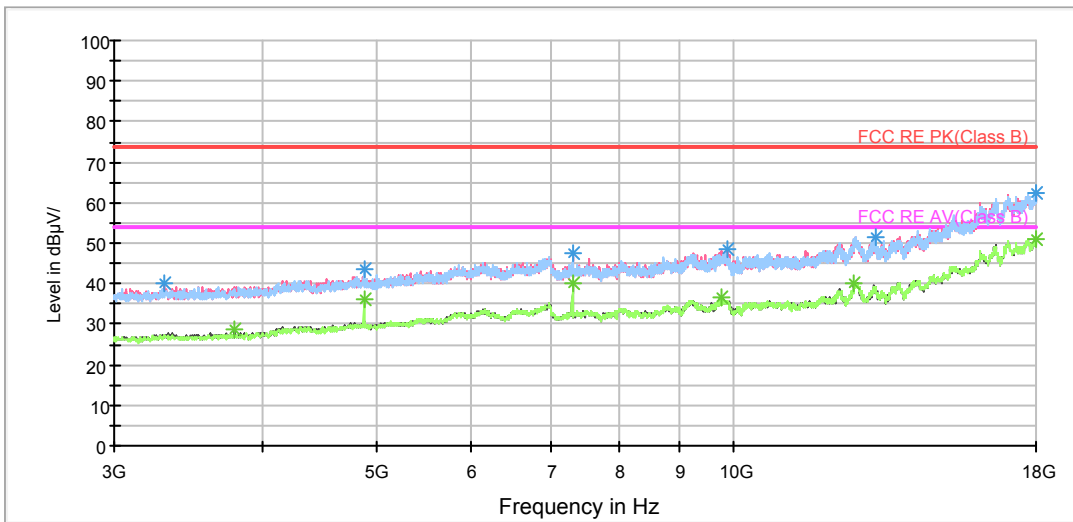

Radiates Emission from 3GHz to 18GHz

BELL_RE 18-26.5GHz PK+AV

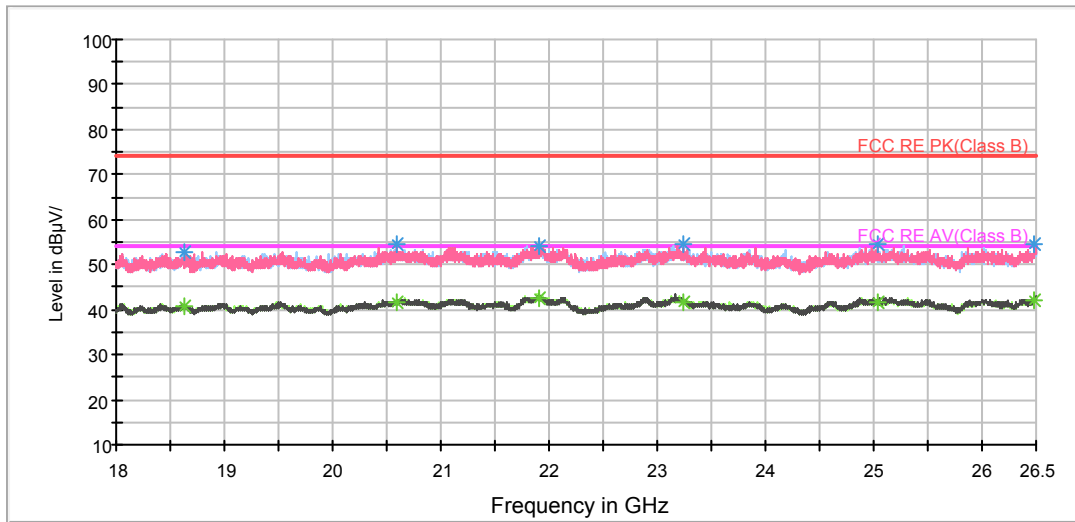

Radiates Emission from 18GHz to 26.5GHz

Frequency (MHz)	Peak (dBuV/m)	Height (cm)	Polarization	Azimuth (deg)	Reading value (dBuV/m)	Correct Factor (dB)	Margin (dB)	Limit (dBuV/m)
1024.000000	49.5	150.0	H	90.0	48.6	0.9	24.5	74
1384.750000	50.6	150.0	H	46.0	47.6	3.0	23.4	74
1646.750000	52.3	150.0	H	0.0	47.3	5.0	21.7	74
1931.500000	54.2	150.0	V	242.0	47.9	6.3	19.8	74
2167.000000	54.4	150.0	V	98.0	46.6	7.8	19.6	74
2927.500000	59.3	150.0	V	250.0	47.6	11.7	14.7	74

Remark: 1. Correction Factor = Antenna factor+ Insertion loss (cable loss + amplifier gain)

Frequency (MHz)	Average (dBuV/m)	Height (cm)	Polarization	Azimuth (deg)	Reading value (dBuV/m)	Correct Factor (dB)	Margin (dB)	Limit (dBuV/m)
1194.250000	39.0	150.0	H	0.0	37.2	1.8	15.0	54
1416.500000	40.1	150.0	V	215.0	37.1	3.0	13.9	54
1731.500000	42.1	150.0	V	336.0	36.9	5.2	11.9	54
2054.000000	43.7	150.0	V	276.0	36.9	6.8	10.3	54
2205.500000	43.8	150.0	H	28.0	35.9	7.9	10.2	54
2933.500000	48.7	150.0	H	226.0	36.9	11.8	5.3	54

Remark: 1. Correction Factor = Antenna factor+ Insertion loss (cable loss + amplifier gain)

802.11b CH11

RE 1G-3GHz PK+AV

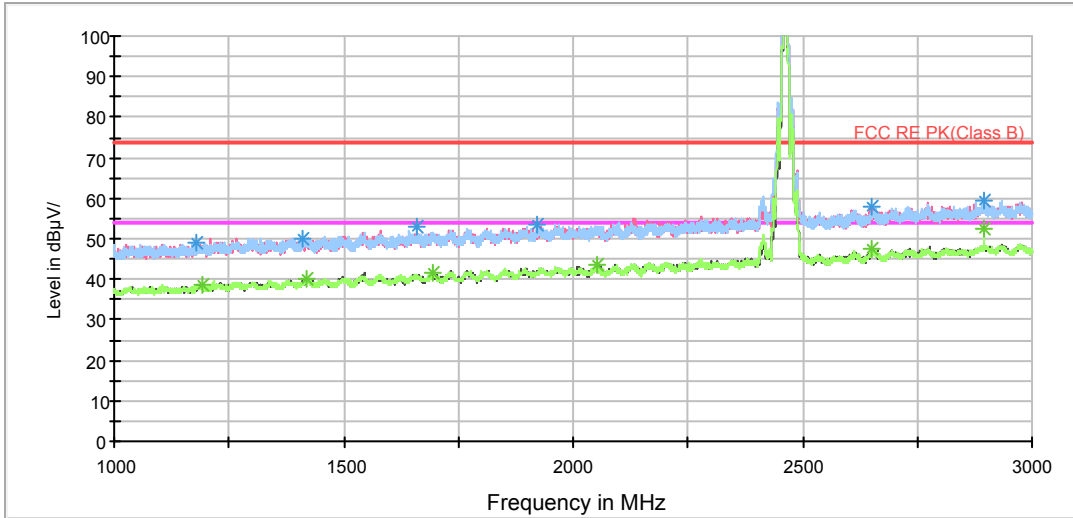

Note: The signal beyond the limit is carrier.
Radiates Emission from 1GHz to 3GHz

RE 3-18GHz PK+AV

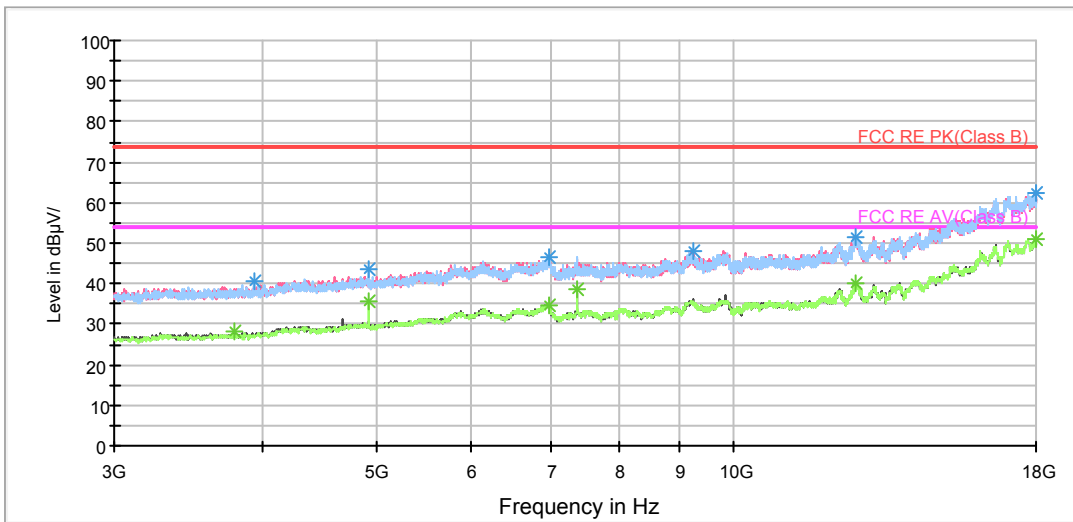

Radiates Emission from 3GHz to 18GHz

BELL_RE 18-26.5GHz PK+AV

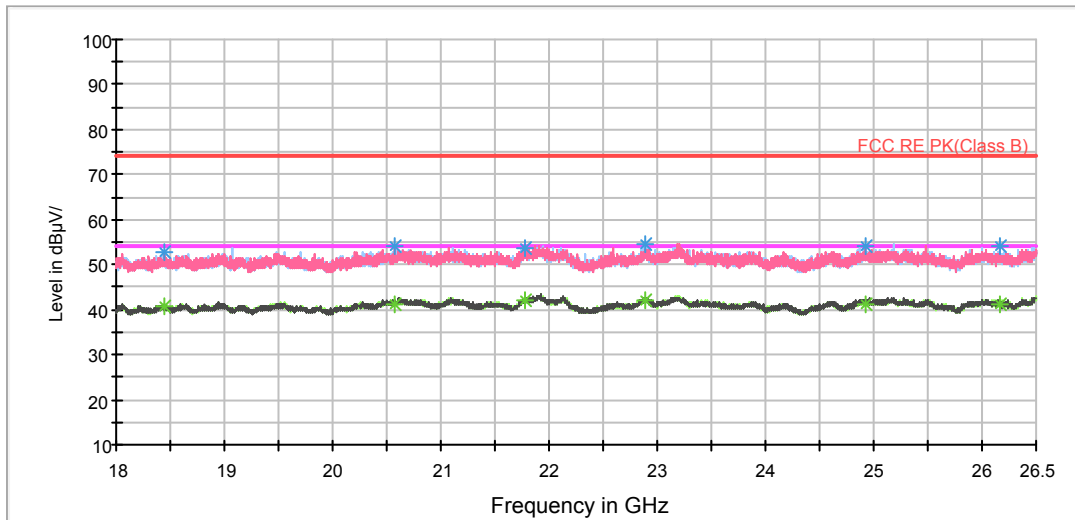

Radiates Emission from 18GHz to 26.5GHz

Frequency (MHz)	Peak (dBuV/m)	Height (cm)	Polarization	Azimuth (deg)	Reading value (dBuV/m)	Correct Factor (dB)	Margin (dB)	Limit (dBuV/m)
1178.000000	48.9	150.0	H	21.0	46.9	2.0	25.1	74
1412.250000	50.2	150.0	V	62.0	47.3	2.9	23.8	74
1660.500000	52.7	150.0	H	184.0	47.9	4.8	21.3	74
1919.250000	53.3	150.0	H	86.0	47.4	5.9	20.7	74
2652.500000	57.9	150.0	V	308.0	47.5	10.4	16.1	74
2895.500000	59.6	150.0	H	0.0	47.5	12.1	14.4	74

Remark: 1. Correction Factor = Antenna factor+ Insertion loss (cable loss + amplifier gain)

Frequency (MHz)	Average (dBuV/m)	Height (cm)	Polarization	Azimuth (deg)	Reading value (dBuV/m)	Correct Factor (dB)	Margin (dB)	Limit (dBuV/m)
1192.250000	38.7	150.0	H	112.0	36.9	1.8	15.3	54
1419.250000	40.2	150.0	V	99.0	37.1	3.1	13.8	54
1696.000000	41.8	150.0	V	186.0	36.8	5.0	12.2	54
2053.750000	43.4	150.0	V	245.0	36.6	6.8	10.6	54
2652.500000	47.3	150.0	H	57.0	36.9	10.4	6.7	54
2895.250000	52.7	150.0	H	12.0	40.6	12.1	1.3	54

Remark: 1. Correction Factor = Antenna factor+ Insertion loss (cable loss + amplifier gain)

802.11g CH1

RE 1G-3GHz PK+AV

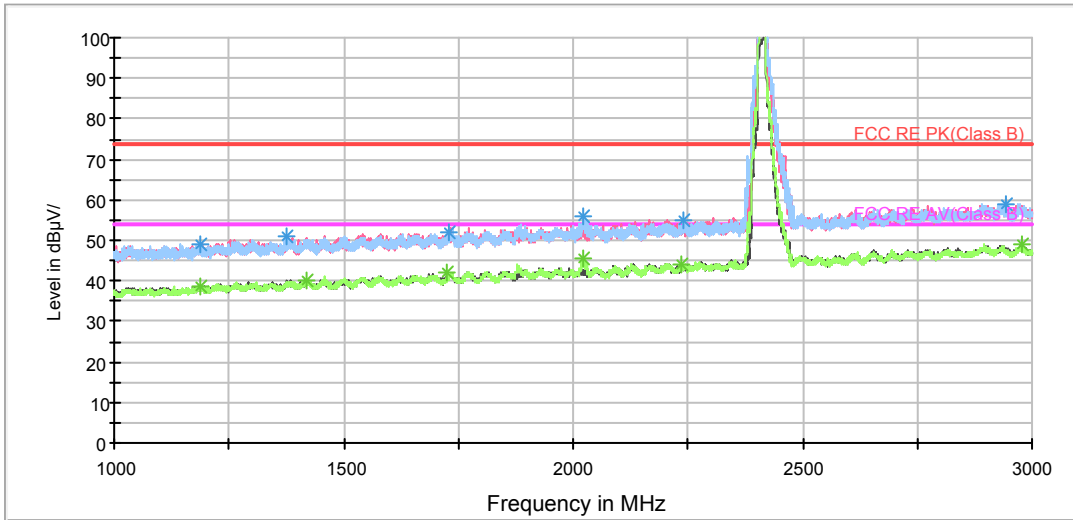

Note: The signal beyond the limit is carrier.
Radiates Emission from 1GHz to 3GHz

RE 3-18GHz PK+AV

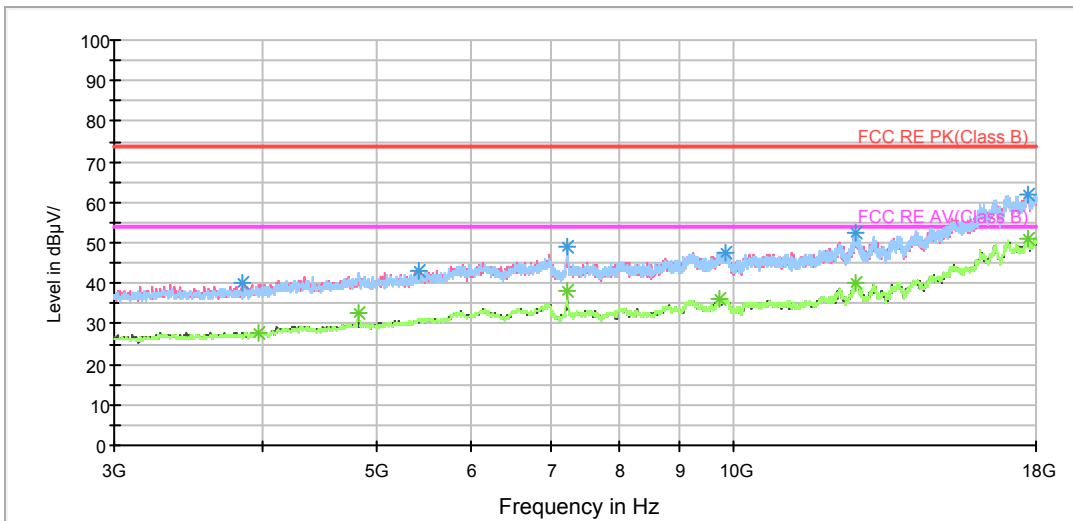

Radiates Emission from 3GHz to 18GHz

BELL_RE 18-26.5GHz PK+AV

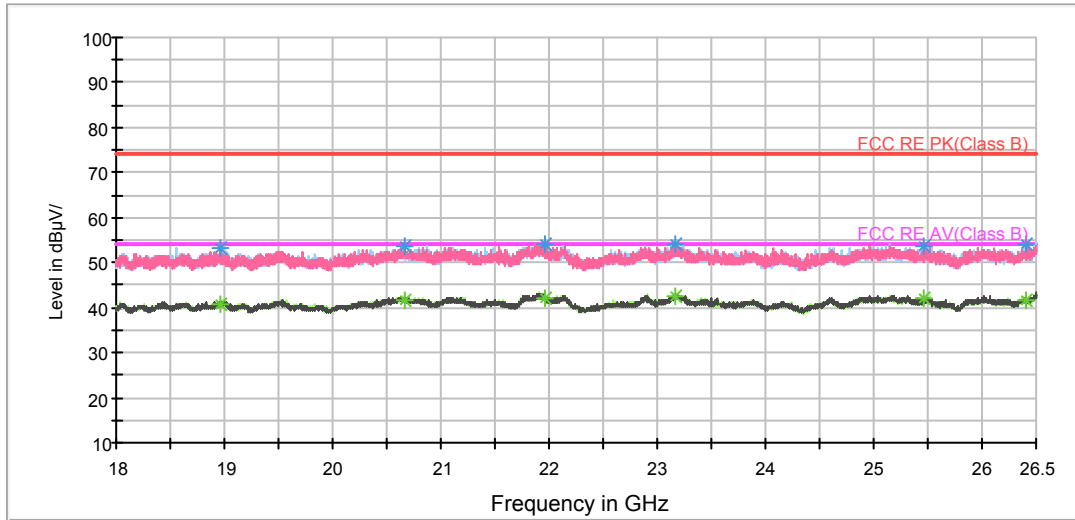

Radiates Emission from 18GHz to 26.5GHz

Frequency (MHz)	Peak (dBuV/m)	Height (cm)	Polarization	Azimuth (deg)	Reading value (dBuV/m)	Correct Factor (dB)	Margin (dB)	Limit (dBuV/m)
1187.750000	49.1	150.0	V	343.0	47.2	1.9	24.9	74
1375.500000	50.7	150.0	H	272.0	47.8	2.9	23.3	74
1730.500000	51.8	150.0	H	246.0	46.7	5.1	22.2	74
2023.750000	56.0	150.0	H	0.0	49.5	6.5	18.0	74
2238.750000	55.0	150.0	H	182.0	47.5	7.5	19.0	74
2943.250000	59.1	150.0	V	273.0	47.1	12.0	14.9	74

Remark: 1. Correction Factor = Antenna factor+ Insertion loss (cable loss + amplifier gain)

Frequency (MHz)	Average (dBuV/m)	Height (cm)	Polarization	Azimuth (deg)	Reading value (dBuV/m)	Correct Factor (dB)	Margin (dB)	Limit (dBuV/m)
1187.750000	38.9	150.0	V	343.0	37.0	1.9	15.1	54
1418.750000	40.2	150.0	V	228.0	37.1	3.1	13.8	54
1725.250000	41.9	150.0	V	325.0	36.9	5.0	12.1	54
2023.500000	45.5	150.0	H	0.0	39.0	6.5	8.5	54
2236.500000	43.9	150.0	V	308.0	36.4	7.5	10.1	54
2977.000000	48.9	150.0	V	351.0	36.7	12.2	5.1	54

Remark: 1. Correction Factor = Antenna factor+ Insertion loss (cable loss + amplifier gain)

802.11g CH6

RE 1G-3GHz PK+AV

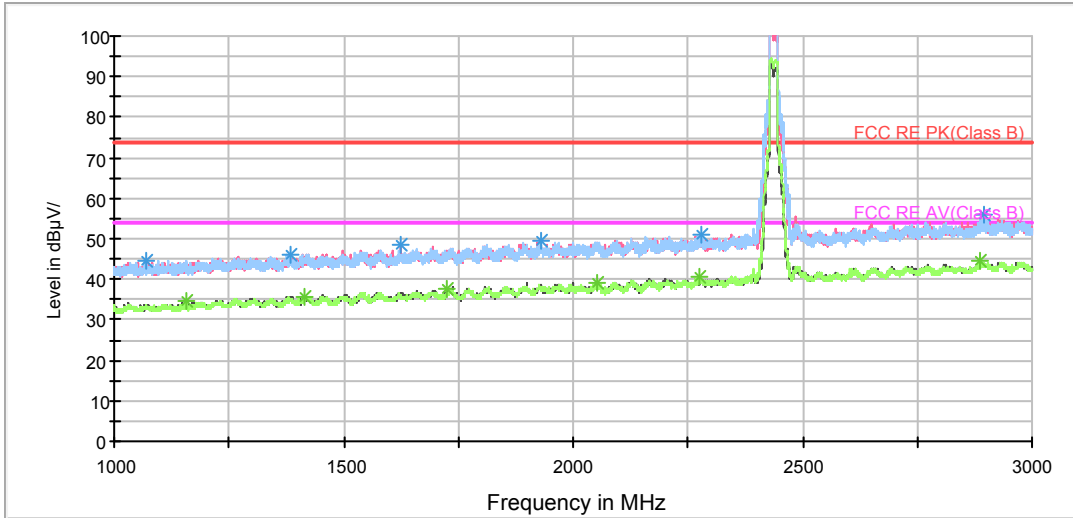

Note: The signal beyond the limit is carrier.
Radiates Emission from 1GHz to 3GHz

RE 3-18GHz PK+AV

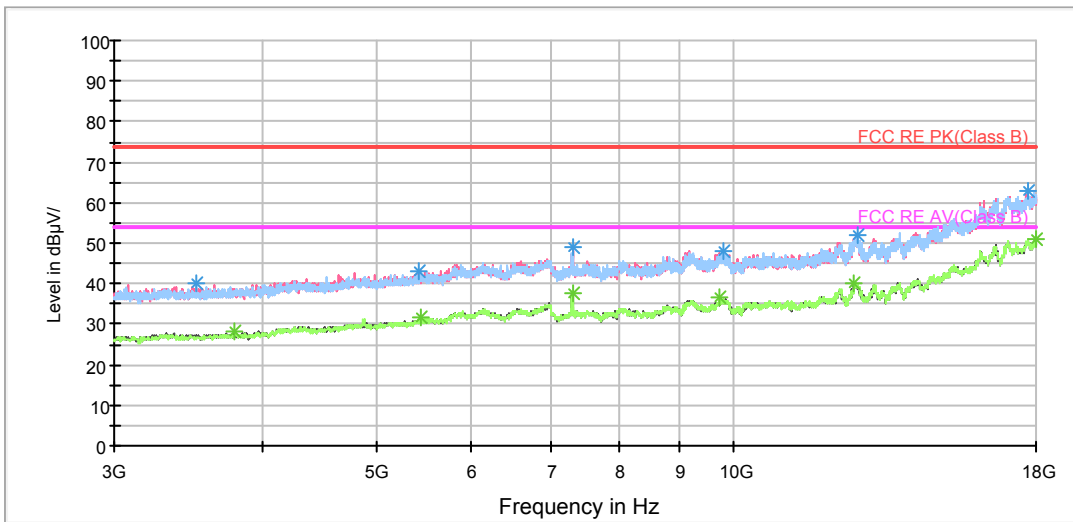

Radiates Emission from 3GHz to 18GHz

BELL_RE 18-26.5GHz PK+AV

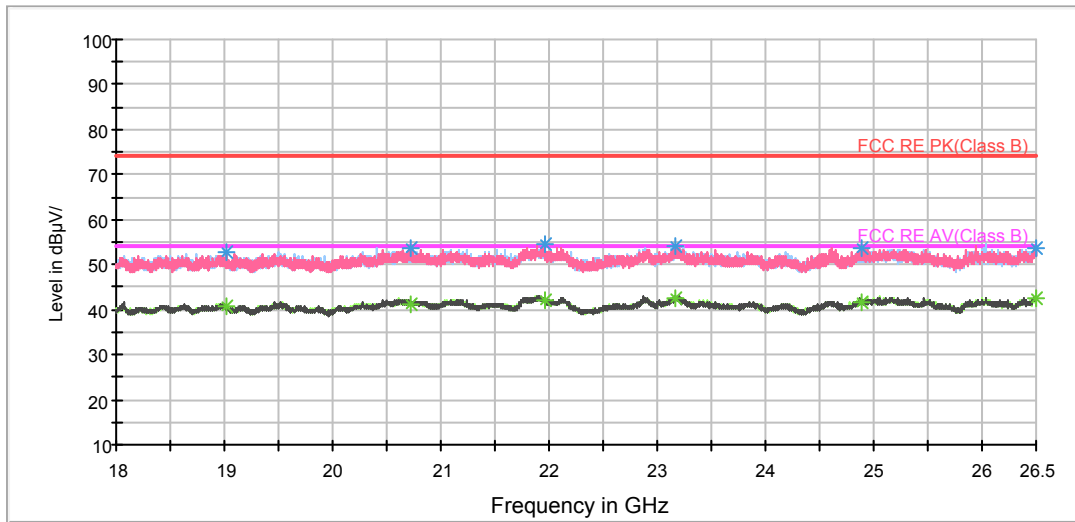

Radiates Emission from 18GHz to 26.5GHz

Frequency (MHz)	Peak (dBuV/m)	Height (cm)	Polarization	Azimuth (deg)	Reading value (dBuV/m)	Correct Factor (dB)	Margin (dB)	Limit (dBuV/m)
1068.500000	44.5	150.0	V	231.0	47.3	-2.8	29.5	74
1384.250000	46.2	150.0	H	0.0	47.2	-1.0	27.8	74
1626.000000	48.4	150.0	V	178.0	47.2	1.2	25.6	74
1932.000000	49.3	150.0	H	59.0	47.0	2.3	24.7	74
2280.250000	51.0	150.0	H	77.0	46.3	4.7	23.0	74
2896.000000	55.9	150.0	H	148.0	47.8	8.1	18.1	74

Remark: 1. Correction Factor = Antenna factor+ Insertion loss (cable loss + amplifier gain)

Frequency (MHz)	Average (dBuV/m)	Height (cm)	Polarization	Azimuth (deg)	Reading value (dBuV/m)	Correct Factor (dB)	Margin (dB)	Limit (dBuV/m)
1159.000000	34.6	150.0	H	192.0	37.0	-2.4	19.4	54
1413.250000	35.8	150.0	H	68.0	36.9	-1.1	18.2	54
1725.250000	37.8	150.0	V	327.0	36.8	1.0	16.2	54
2052.500000	39.0	150.0	V	240.0	36.2	2.8	15.0	54
2273.750000	40.4	150.0	V	275.0	35.9	4.5	13.6	54
2884.500000	44.3	150.0	H	165.0	36.1	8.2	9.7	54

Remark: 1. Correction Factor = Antenna factor+ Insertion loss (cable loss + amplifier gain)



802.11g CH11

RE 1G-3GHz PK+AV

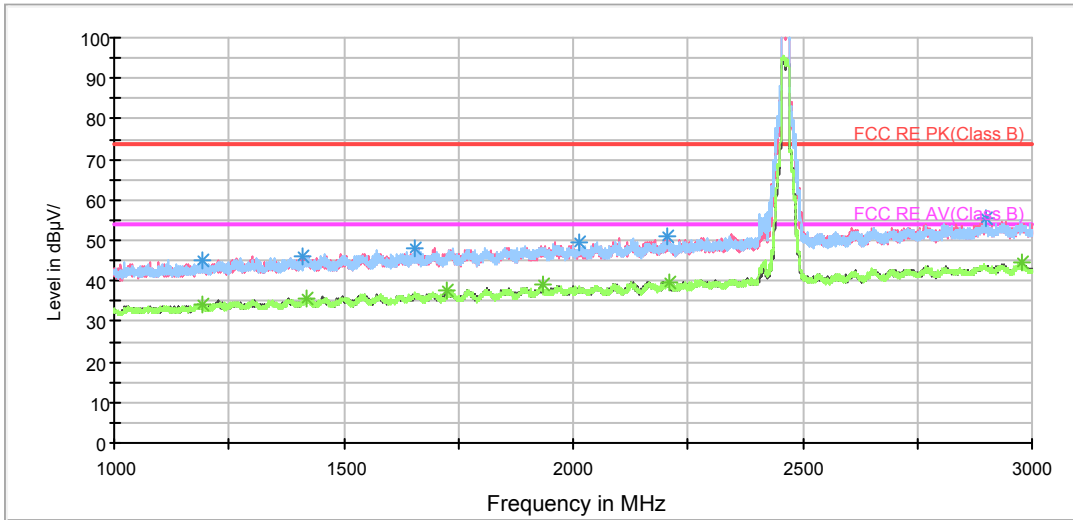

Note: The signal beyond the limit is carrier.
Radiates Emission from 1GHz to 3GHz

RE 3-18GHz PK+AV

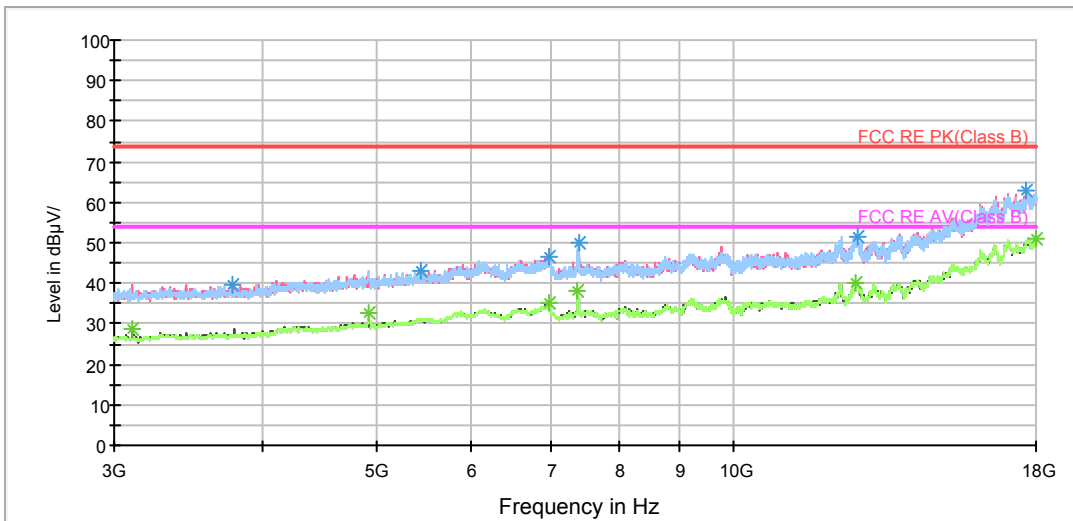

Radiates Emission from 3GHz to 18GHz

BELL_RE 18-26.5GHz PK+AV

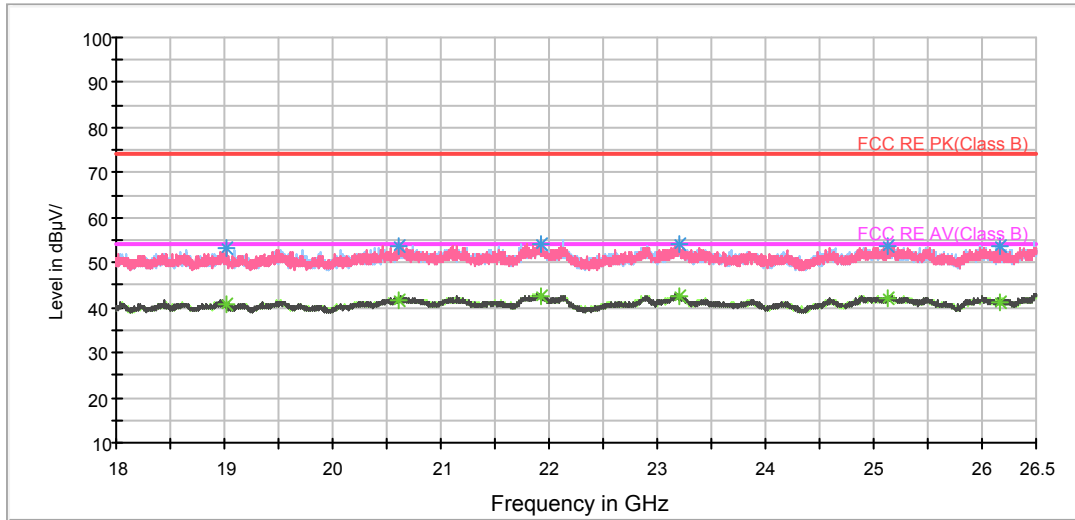

Radiates Emission from 18GHz to 26.5GHz

Frequency (MHz)	Peak (dBuV/m)	Height (cm)	Polarization	Azimuth (deg)	Reading value (dBuV/m)	Correct Factor (dB)	Margin (dB)	Limit (dBuV/m)
1190.250000	45.3	150.0	H	0.0	47.5	-2.2	28.7	74
1412.250000	46.3	150.0	V	284.0	47.4	-1.1	27.7	74
1655.750000	48.1	150.0	V	158.0	47.2	0.9	25.9	74
2014.000000	49.7	150.0	V	28.0	47.2	2.5	24.3	74
2206.000000	51.0	150.0	H	316.0	47.1	3.9	23.0	74
2899.500000	55.2	150.0	V	273.0	47.1	8.1	18.8	74

Remark: 1. Correction Factor = Antenna factor+ Insertion loss (cable loss + amplifier gain)

Frequency (MHz)	Average (dBuV/m)	Height (cm)	Polarization	Azimuth (deg)	Reading value (dBuV/m)	Correct Factor (dB)	Margin (dB)	Limit (dBuV/m)
1191.750000	34.4	150.0	H	121.0	36.6	-2.2	19.6	54
1418.750000	35.8	150.0	V	331.0	36.7	-0.9	18.2	54
1724.750000	37.5	150.0	V	322.0	36.5	1.0	16.5	54
1933.750000	38.9	150.0	V	354.0	36.6	2.3	15.1	54
2211.750000	39.5	150.0	V	0.0	35.7	3.8	14.5	54
2976.000000	44.4	150.0	H	58.0	36.2	8.2	9.6	54

Remark: 1. Correction Factor = Antenna factor+ Insertion loss (cable loss + amplifier gain)

MIMO

802.11n (HT20) CH1

RE 1G-6GHz PK+AV Class B

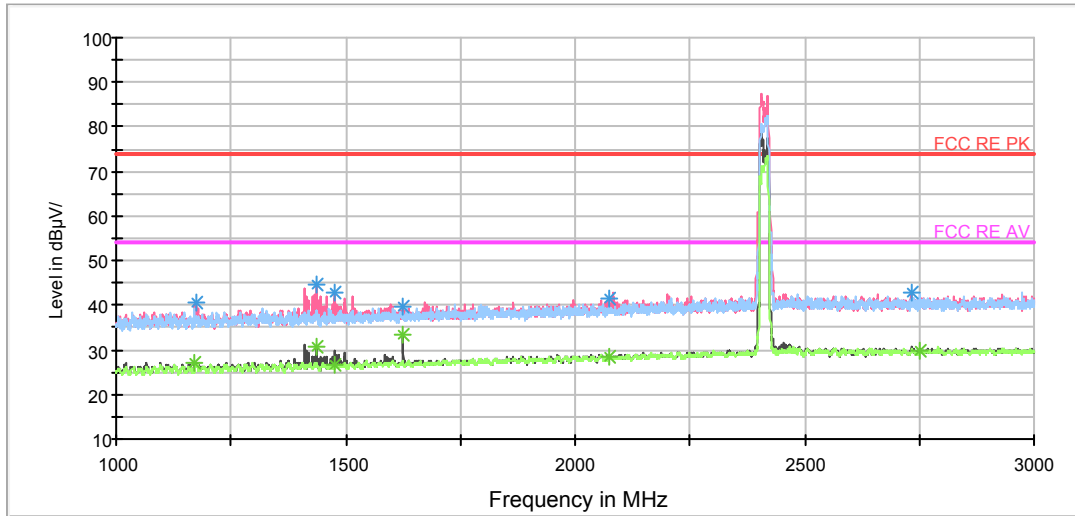

Note: The signal beyond the limit is carrier.
Radiates Emission from 1GHz to 3GHz

RE 3-18GHz PK+AV

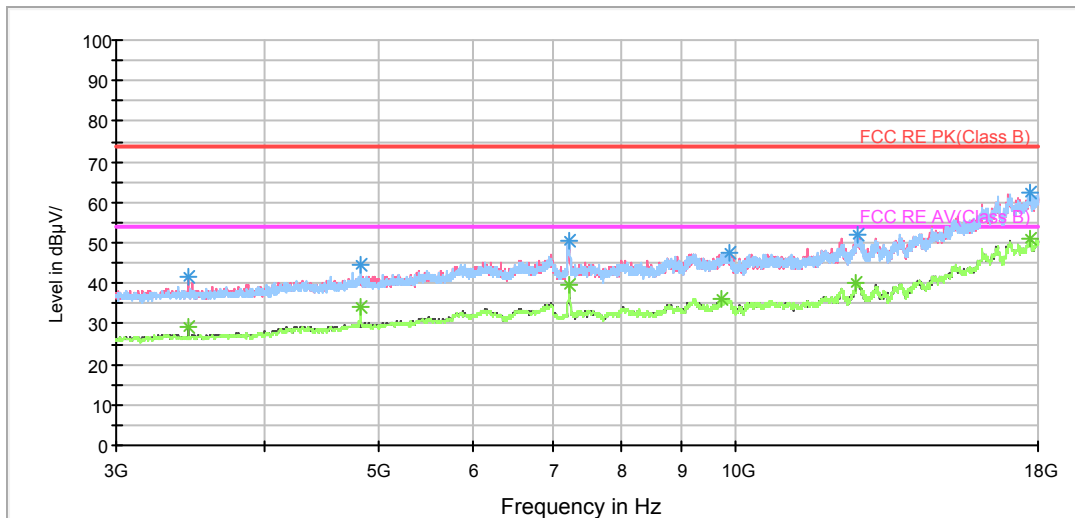

Radiates Emission from 3GHz to 18GHz

BELL_RE 18-26.5GHz PK+AV

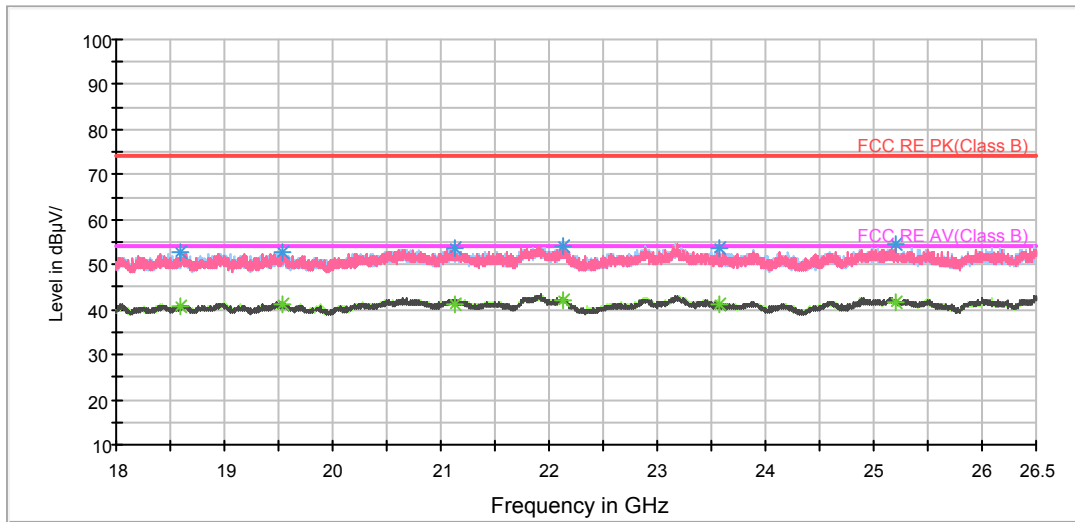

Radiates Emission from 18GHz to 26.5GHz

Frequency (MHz)	Peak (dBuV/m)	Height (cm)	Polarization	Azimuth (deg)	Reading value (dBuV/m)	Correct Factor (dB)	Margin (dB)	Limit (dBuV/m)
1174.000000	40.5	100.0	V	159.0	48.1	-7.6	33.5	74
1436.000000	44.7	100.0	V	174.0	51.5	-6.8	29.3	74
1476.000000	42.8	100.0	V	129.0	49.5	-6.7	31.2	74
1625.600000	39.5	100.0	V	84.0	45.7	-6.2	34.5	74
2073.600000	41.4	100.0	V	196.0	45.9	-4.5	32.6	74
2731.600000	43.0	100.0	V	354.0	45.6	-2.6	31.0	74

Remark: 1. Correction Factor = Antenna factor+ Insertion loss (cable loss + amplifier gain)

Frequency (MHz)	Average (dBuV/m)	Height (cm)	Polarization	Azimuth (deg)	Reading value (dBuV/m)	Correct Factor (dB)	Margin (dB)	Limit (dBuV/m)
1172.000000	27.1	100.0	V	159.0	34.7	-7.6	26.9	54
1436.000000	30.6	100.0	V	174.0	37.4	-6.8	23.4	54
1476.000000	26.7	100.0	V	129.0	33.4	-6.7	27.3	54
1625.600000	33.3	100.0	V	84.0	39.5	-6.2	20.7	54
2073.600000	28.5	100.0	V	196.0	33.0	-4.5	25.5	54
2750.000000	29.7	100.0	H	27.0	32.3	-2.6	24.3	54

Remark: 1. Correction Factor = Antenna factor+ Insertion loss (cable loss + amplifier gain)

802.11n (HT20) CH6

RE 1G-6GHz PK+AV Class B

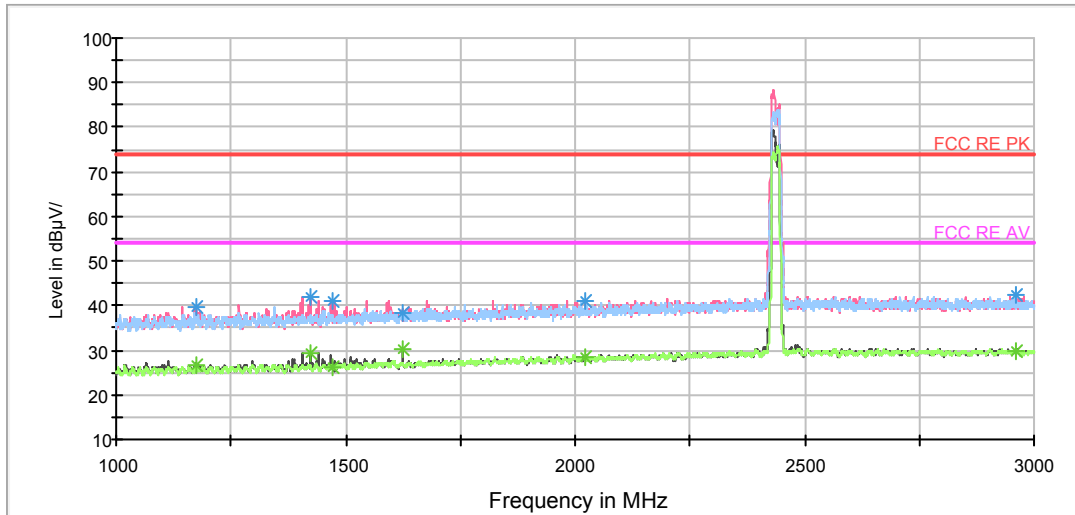

Note: The signal beyond the limit is carrier.
Radiates Emission from 1GHz to 3GHz

RE 3-18GHz PK+AV

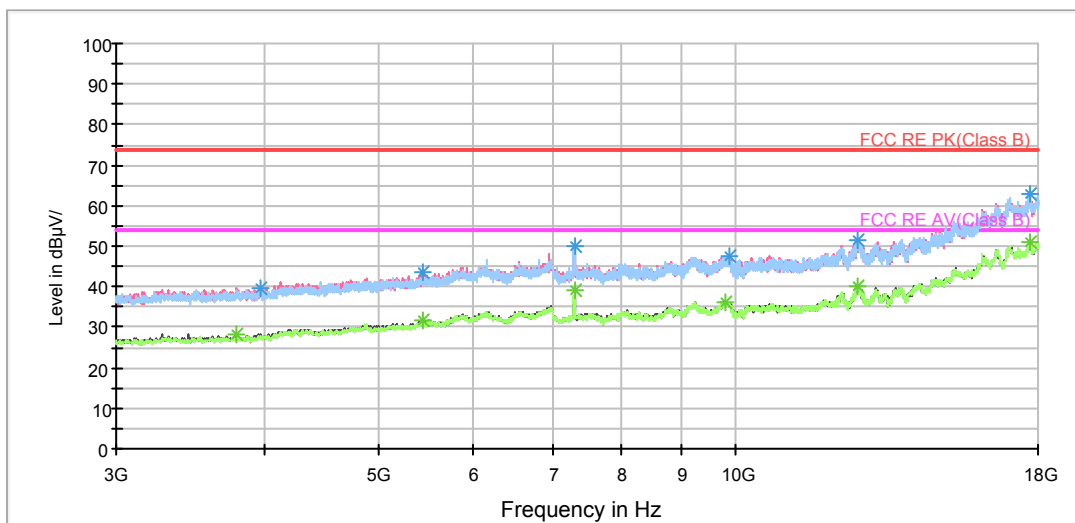

Radiates Emission from 3GHz to 18GHz

BELL_RE 18-26.5GHz PK+AV

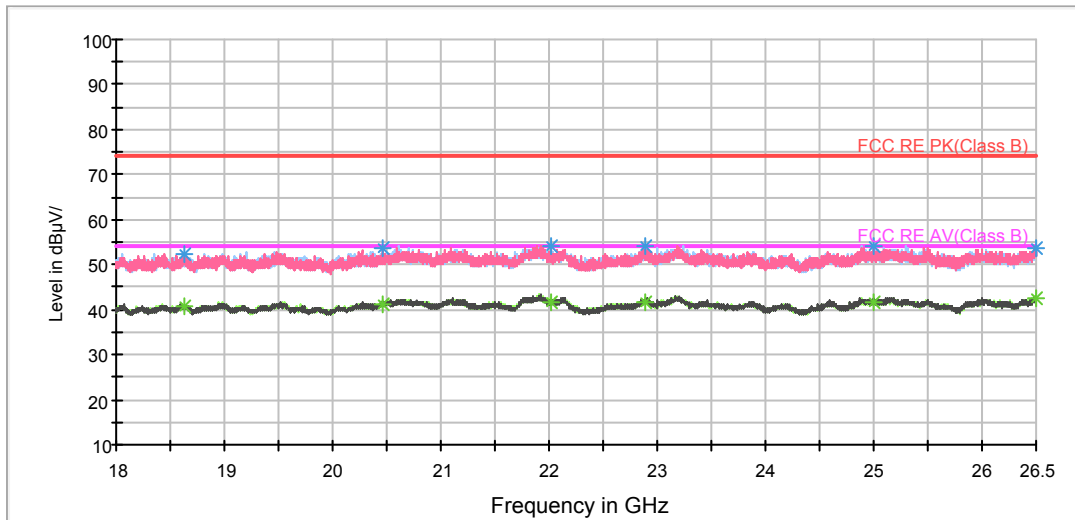

Radiates Emission from 18GHz to 26.5GHz

Frequency (MHz)	Peak (dBuV/m)	Height (cm)	Polarization	Azimuth (deg)	Reading value (dBuV/m)	Correct Factor (dB)	Margin (dB)	Limit (dBuV/m)
1174.000000	39.9	100.0	V	157.0	47.5	-7.6	34.1	74
1423.600000	42.1	100.0	V	150.0	49.0	-6.9	31.9	74
1470.800000	41.2	100.0	V	180.0	47.9	-6.7	32.8	74
1625.600000	38.4	100.0	V	297.0	44.6	-6.2	35.6	74
2020.800000	41.0	100.0	V	128.0	45.7	-4.7	33.0	74
2962.400000	42.3	100.0	H	48.0	44.8	-2.5	31.7	74

Remark: 1. Correction Factor = Antenna factor+ Insertion loss (cable loss + amplifier gain)

Frequency (MHz)	Average (dBuV/m)	Height (cm)	Polarization	Azimuth (deg)	Reading value (dBuV/m)	Correct Factor (dB)	Margin (dB)	Limit (dBuV/m)
1174.000000	26.8	100.0	V	157.0	34.4	-7.6	27.2	54
1423.600000	29.2	100.0	V	150.0	36.1	-6.9	24.8	54
1470.800000	26.3	100.0	V	180.0	33.0	-6.7	27.7	54
1625.600000	30.3	100.0	V	297.0	36.5	-6.2	23.7	54
2020.800000	28.2	100.0	V	128.0	32.9	-4.7	25.8	54
2962.400000	29.6	100.0	H	48.0	32.1	-2.5	24.4	54

Remark: 1. Correction Factor = Antenna factor+ Insertion loss (cable loss + amplifier gain)

802.11n (HT20) CH11

RE 1G-6GHz PK+AV Class B

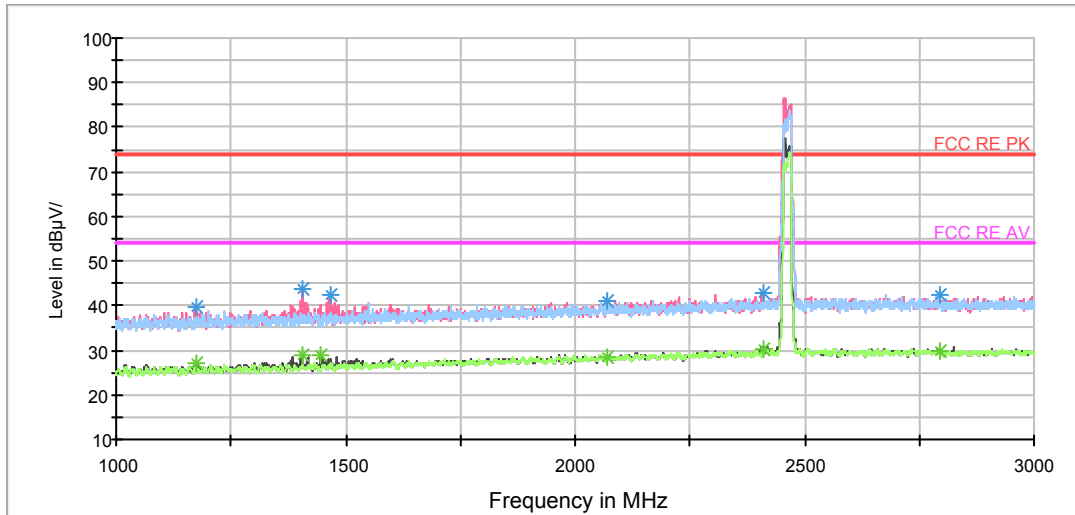

Note: The signal beyond the limit is carrier.
Radiates Emission from 1GHz to 3GHz

RE 3-18GHz PK+AV

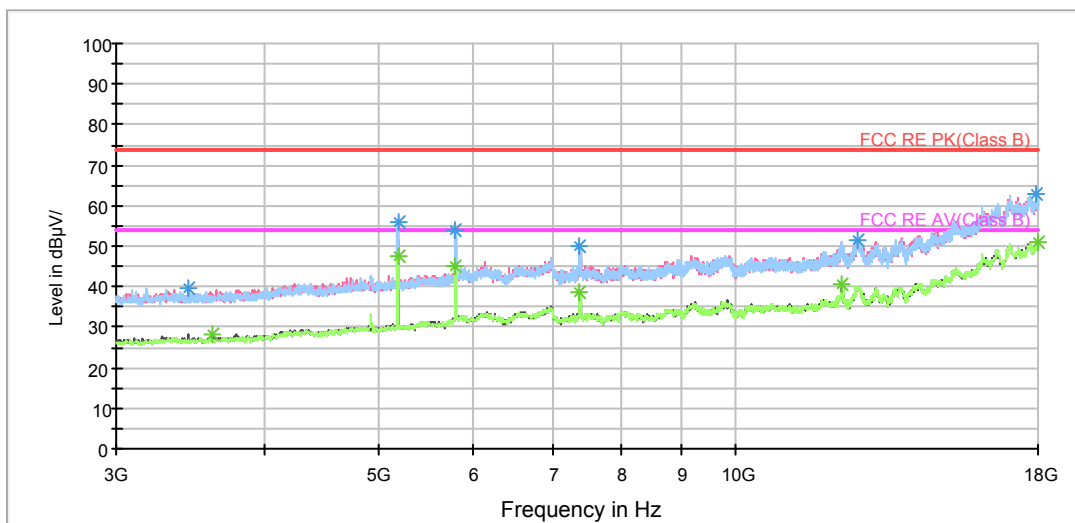

Radiates Emission from 3GHz to 18GHz

BELL_RE 18-26.5GHz PK+AV

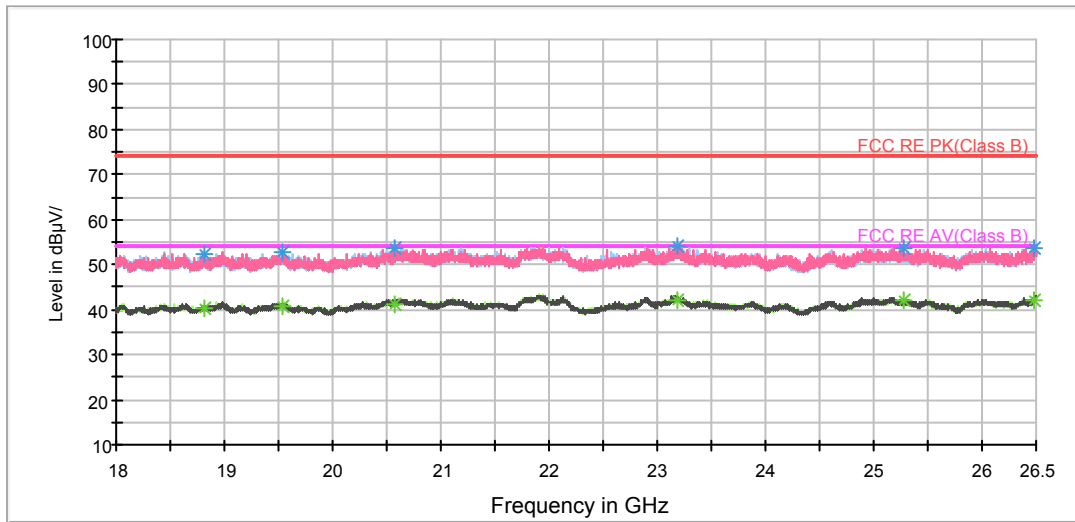

Radiates Emission from 18GHz to 26.5GHz

Frequency (MHz)	Peak (dBuV/m)	Height (cm)	Polarization	Azimuth (deg)	Reading value (dBuV/m)	Correct Factor (dB)	Margin (dB)	Limit (dBuV/m)
1172.800000	39.6	100.0	V	136.0	47.2	-7.6	34.4	74
1404.400000	43.8	100.0	V	173.0	50.7	-6.9	30.2	74
1466.800000	42.2	100.0	V	218.0	48.9	-6.7	31.8	74
2070.400000	41.1	100.0	V	308.0	45.6	-4.5	32.9	74
2409.200000	42.9	100.0	V	99.0	46.1	-3.2	31.1	74
2796.400000	42.3	100.0	H	77.0	44.9	-2.6	31.7	74

Remark: 1. Correction Factor = Antenna factor+ Insertion loss (cable loss + amplifier gain)

Frequency (MHz)	Average (dBuV/m)	Height (cm)	Polarization	Azimuth (deg)	Reading value (dBuV/m)	Correct Factor (dB)	Margin (dB)	Limit (dBuV/m)
1174.400000	27.3	100.0	V	159.0	34.9	-7.6	26.7	54
1404.400000	29.1	100.0	V	173.0	36.0	-6.9	24.9	54
1446.000000	29.0	100.0	V	173.0	35.8	-6.8	25.0	54
2070.400000	28.2	100.0	V	308.0	32.7	-4.5	25.8	54
2409.200000	30.2	100.0	V	99.0	33.4	-3.2	23.8	54
2796.400000	29.8	100.0	H	77.0	32.4	-2.6	24.2	54

Remark: 1. Correction Factor = Antenna factor+ Insertion loss (cable loss + amplifier gain)

802.11n (HT40) CH3

RE 1G-6GHz PK+AV Class B

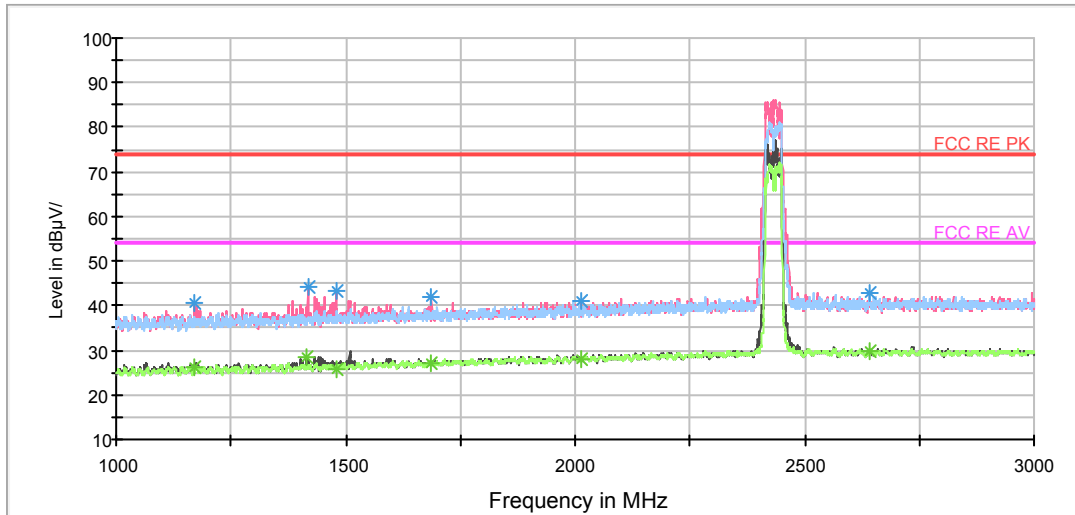

Note: The signal beyond the limit is carrier.
Radiates Emission from 1GHz to 3GHz

RE 3-18GHz PK+AV

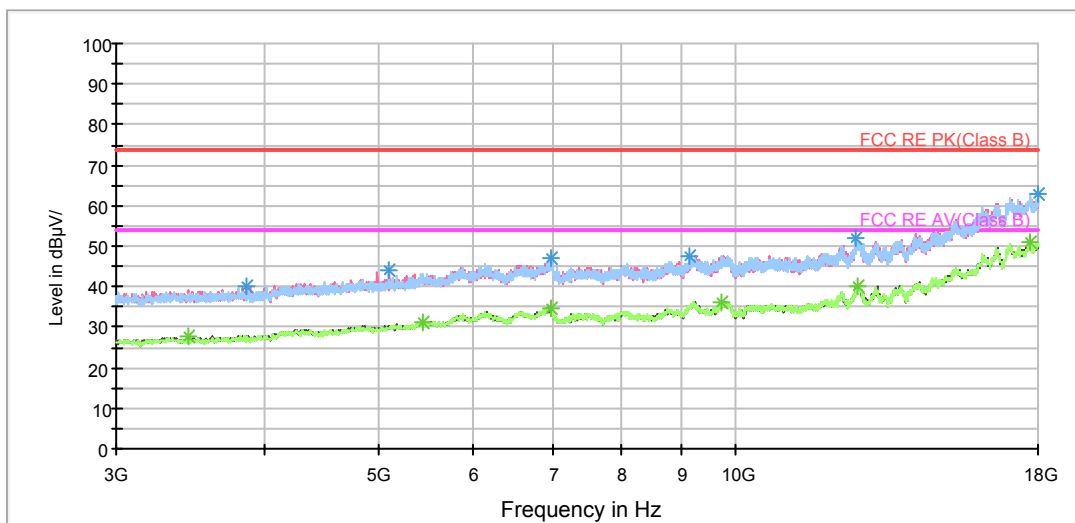

Radiates Emission from 3GHz to 18GHz

BELL_RE 18-26.5GHz PK+AV

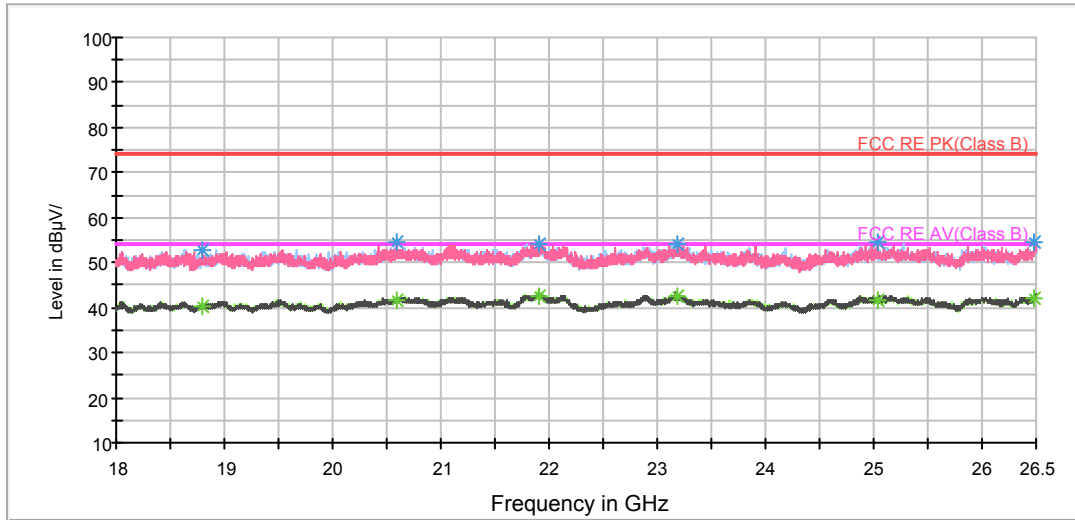

Radiates Emission from 18GHz to 26.5GHz

Frequency (MHz)	Peak (dBuV/m)	Height (cm)	Polarization	Azimuth (deg)	Reading value (dBuV/m)	Correct Factor (dB)	Margin (dB)	Limit (dBuV/m)
1172.000000	40.4	100.0	V	52.0	48.0	-7.6	33.6	74
1417.200000	44.2	100.0	V	92.0	51.1	-6.9	29.8	74
1478.400000	43.5	100.0	V	222.0	50.2	-6.7	30.5	74
1687.600000	42.0	100.0	V	174.0	47.9	-5.9	32.0	74
2013.600000	41.0	100.0	V	107.0	45.8	-4.8	33.0	74
2642.000000	42.9	100.0	H	32.0	45.6	-2.7	31.1	74

Remark: 1. Correction Factor = Antenna factor+ Insertion loss (cable loss + amplifier gain)

Frequency (MHz)	Average (dBuV/m)	Height (cm)	Polarization	Azimuth (deg)	Reading value (dBuV/m)	Correct Factor (dB)	Margin (dB)	Limit (dBuV/m)
1172.000000	26.4	100.0	V	52.0	34.0	-7.6	27.6	54
1416.400000	28.4	100.0	V	144.0	35.3	-6.9	25.6	54
1478.400000	25.8	100.0	V	222.0	32.5	-6.7	28.2	54
1687.600000	27.0	100.0	V	174.0	32.9	-5.9	27.0	54
2013.600000	28.1	100.0	V	107.0	32.9	-4.8	25.9	54
2642.000000	29.8	100.0	H	32.0	32.5	-2.7	24.2	54

Remark: 1. Correction Factor = Antenna factor+ Insertion loss (cable loss + amplifier gain)

802.11n (HT40) CH6

RE 1G-6GHz PK+AV Class B

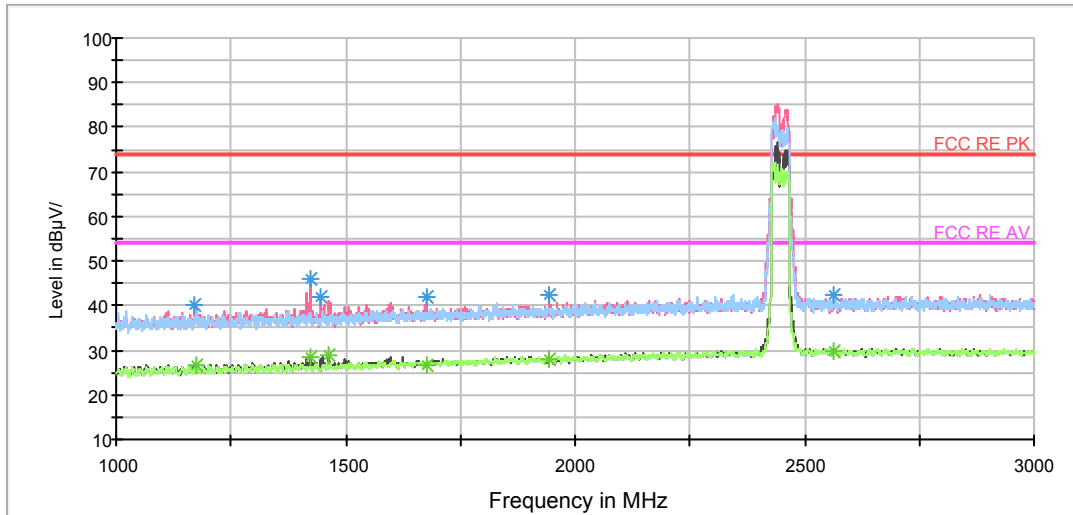

Note: The signal beyond the limit is carrier.
Radiates Emission from 1GHz to 3GHz

RE 3-18GHz PK+AV

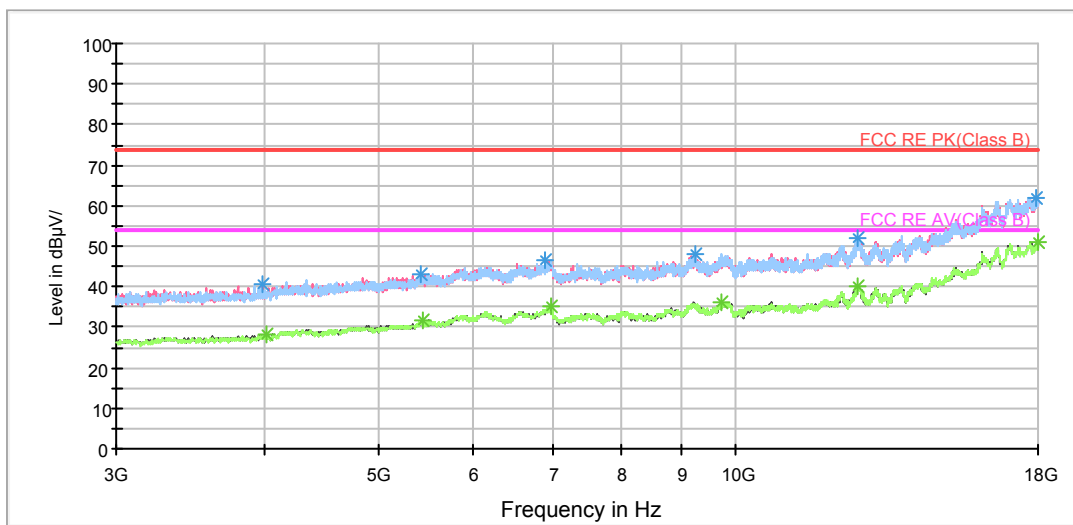

Radiates Emission from 3GHz to 18GHz

BELL_RE 18-26.5GHz PK+AV

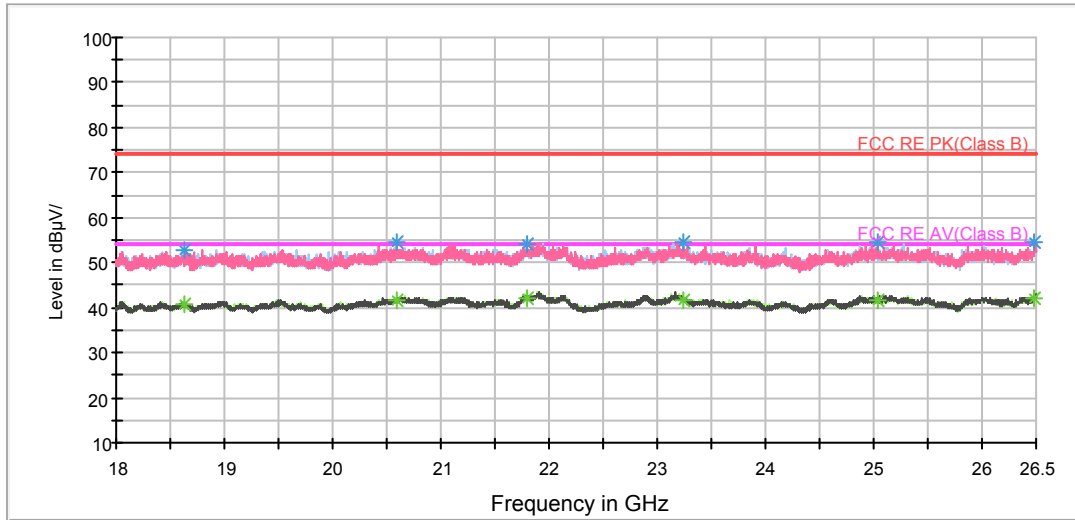

Radiates Emission from 18GHz to 26.5GHz

Frequency (MHz)	Peak (dBuV/m)	Height (cm)	Polarization	Azimuth (deg)	Reading value (dBuV/m)	Correct Factor (dB)	Margin (dB)	Limit (dBuV/m)
1171.600000	40.1	100.0	V	52.0	47.7	-7.6	33.9	74
1423.600000	46.0	100.0	V	174.0	52.9	-6.9	28.0	74
1445.600000	41.8	100.0	V	144.0	48.6	-6.8	32.2	74
1676.800000	41.8	100.0	V	355.0	47.8	-6.0	32.2	74
1944.000000	42.6	100.0	V	130.0	47.6	-5.0	31.4	74
2562.400000	42.4	100.0	V	0.0	45.2	-2.8	31.6	74

Remark: 1. Correction Factor = Antenna factor+ Insertion loss (cable loss + amplifier gain)

Frequency (MHz)	Average (dBuV/m)	Height (cm)	Polarization	Azimuth (deg)	Reading value (dBuV/m)	Correct Factor (dB)	Margin (dB)	Limit (dBuV/m)
1174.000000	26.8	100.0	V	159.0	34.4	-7.6	27.2	54
1423.200000	28.6	100.0	V	174.0	35.5	-6.9	25.4	54
1463.600000	28.9	100.0	V	305.0	35.6	-6.7	25.1	54
1676.800000	26.8	100.0	V	355.0	32.8	-6.0	27.2	54
1944.000000	27.9	100.0	V	130.0	32.9	-5.0	26.1	54
2563.200000	30.0	100.0	V	343.0	32.8	-2.8	24.0	54

Remark: 1. Correction Factor = Antenna factor+ Insertion loss (cable loss + amplifier gain)

802.11n (HT40) CH9

RE 1G-6GHz PK+AV Class B

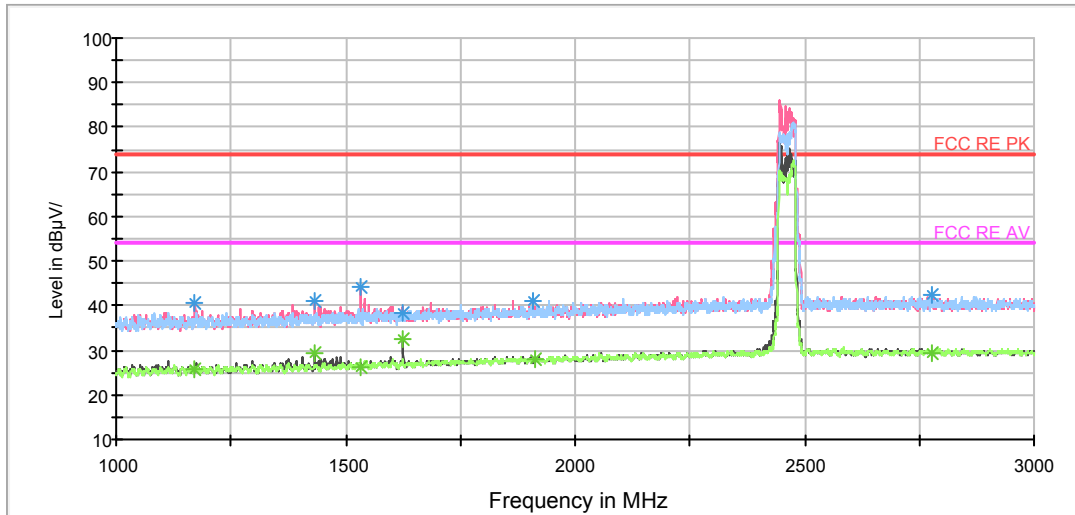

Note: The signal beyond the limit is carrier.
Radiates Emission from 1GHz to 3GHz

RE 3-18GHz PK+AV

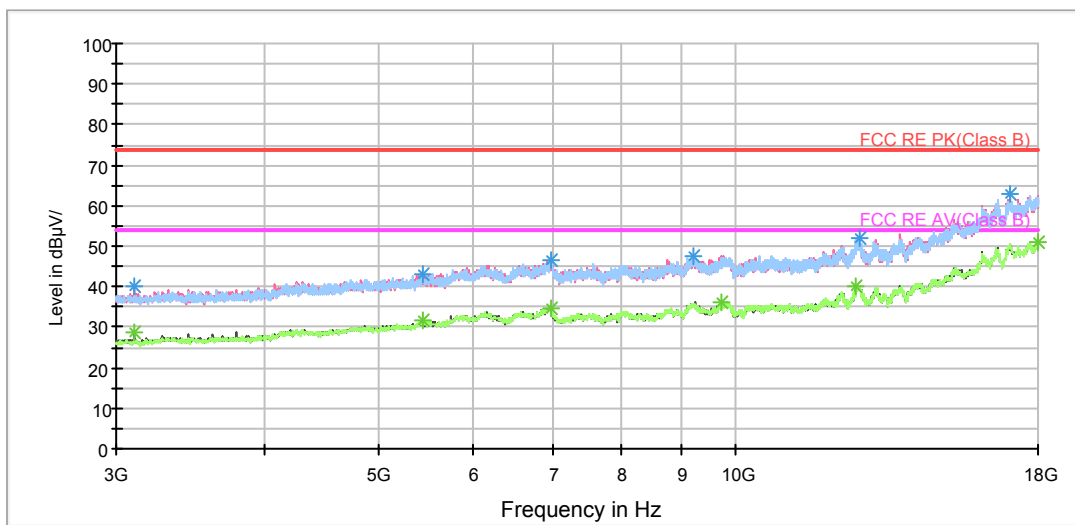

Radiates Emission from 3GHz to 18GHz

BELL_RE 18-26.5GHz PK+AV

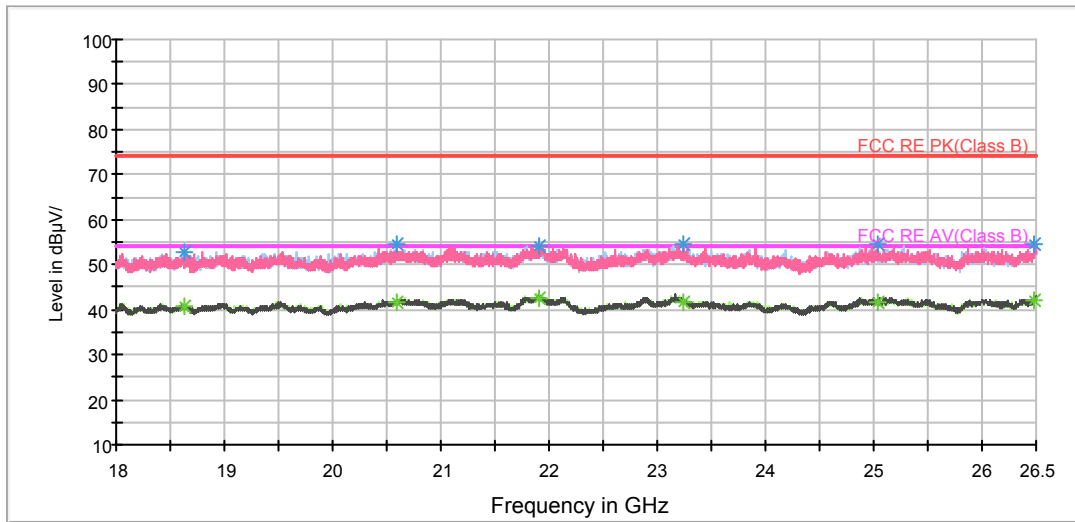

Radiates Emission from 18GHz to 26.5GHz

Frequency (MHz)	Peak (dBuV/m)	Height (cm)	Polarization	Azimuth (deg)	Reading value (dBuV/m)	Correct Factor (dB)	Margin (dB)	Limit (dBuV/m)
1172.400000	40.6	100.0	V	147.0	48.2	-7.6	33.4	74
1433.600000	41.3	100.0	V	207.0	48.1	-6.8	32.7	74
1533.200000	44.1	100.0	V	258.0	50.6	-6.5	29.9	74
1625.600000	38.6	100.0	V	78.0	44.8	-6.2	35.4	74
1907.200000	41.1	100.0	V	207.0	46.2	-5.1	32.9	74
2776.400000	42.5	100.0	H	0.0	45.1	-2.6	31.5	74

Remark: 1. Correction Factor = Antenna factor+ Insertion loss (cable loss + amplifier gain)

Frequency (MHz)	Average (dBuV/m)	Height (cm)	Polarization	Azimuth (deg)	Reading value (dBuV/m)	Correct Factor (dB)	Margin (dB)	Limit (dBuV/m)
1172.400000	26.0	100.0	V	147.0	33.6	-7.6	28.0	54
1434.000000	29.3	100.0	V	207.0	36.1	-6.8	24.7	54
1533.200000	26.3	100.0	V	258.0	32.8	-6.5	27.7	54
1625.600000	32.7	100.0	V	78.0	38.9	-6.2	21.3	54
1913.200000	27.9	100.0	V	93.0	33.0	-5.1	26.1	54
2776.400000	29.3	100.0	H	0.0	31.9	-2.6	24.7	54

Remark: 1. Correction Factor = Antenna factor+ Insertion loss (cable loss + amplifier gain)

5.7. Conducted Emission

Ambient condition

Temperature	Relative humidity	Pressure
23°C ~25°C	45%~50%	101.5kPa

Methods of Measurement

The EUT is placed on a non-metallic table of 80cm height above the horizontal metal reference ground plane. During the test, the EUT was operating in its typical mode. The test method is according to ANSI C63.10-2013. Connect the AC power line of the EUT to the L.I.S.N. Use EMI receiver to detect the average and Quasi-peak value. RBW is set to 9 kHz, VBW is set to 30kHz. The measurement result should include both L line and N line.

The test is in transmitting mode.

Test Setup

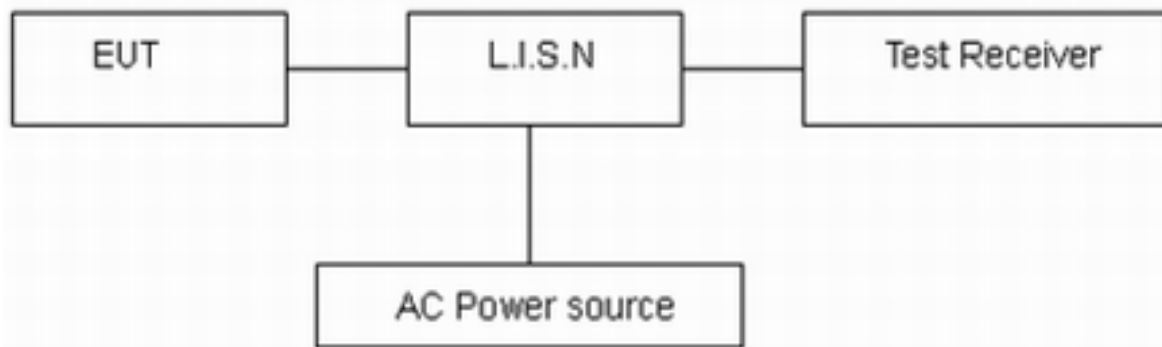

Note: AC Power source is used to change the voltage 110V/60Hz.

Limits

Frequency (MHz)	Conducted Limits(dBμV)	
	Quasi-peak	Average
0.15 - 0.5	66 to 56 *	56 to 46*
0.5 - 5	56	46
5 - 30	60	50

*: Decreases with the logarithm of the frequency.

Measurement Uncertainty

The assessed measurement uncertainty to ensure 95% confidence level for the normal distribution is with the coverage factor $k = 1.96$, $U = 2.69$ dB.

Test Results:

Following plots, Blue trace uses the peak detection and Green trace uses the average detection. During the test, the Conducted Emission was performed in all modes with all channels, 802.11b, Channel 11 are selected as the worst condition. The test data of the worst-case condition was recorded in this report.

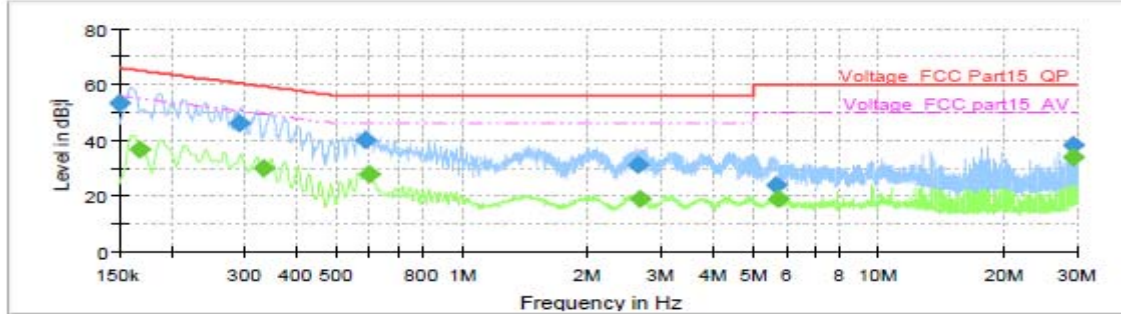

Frequency (MHz)	QuasiPeak (dB; i V)	Average (dB; i V)	Limit (dB; i V)	Margin (dB)	Meas. Time (ms)	Bandwidth (kHz)	Line	Filter	Corr. (dB)
0.150000	53.40	---	66.00	12.60	1000.0	9.000	L1	ON	19.6
0.168000	---	36.90	55.06	18.16	1000.0	9.000	L1	ON	19.6
0.291750	45.94	---	60.47	14.54	1000.0	9.000	L1	ON	19.6
0.332250	---	30.17	49.40	19.22	1000.0	9.000	L1	ON	19.6
0.584250	39.93	---	56.00	16.07	1000.0	9.000	L1	ON	19.6
0.595500	---	27.86	46.00	18.14	1000.0	9.000	L1	ON	19.6
2.638500	31.13	---	56.00	24.87	1000.0	9.000	L1	ON	19.6
2.663250	---	18.71	46.00	27.29	1000.0	9.000	L1	ON	19.6
5.667000	24.07	---	60.00	35.93	1000.0	9.000	L1	ON	19.7
5.736750	---	18.94	50.00	31.06	1000.0	9.000	L1	ON	19.7
29.233500	38.13	---	60.00	21.87	1000.0	9.000	L1	ON	20.1
29.235750	---	34.05	50.00	15.95	1000.0	9.000	L1	ON	20.1

L Line

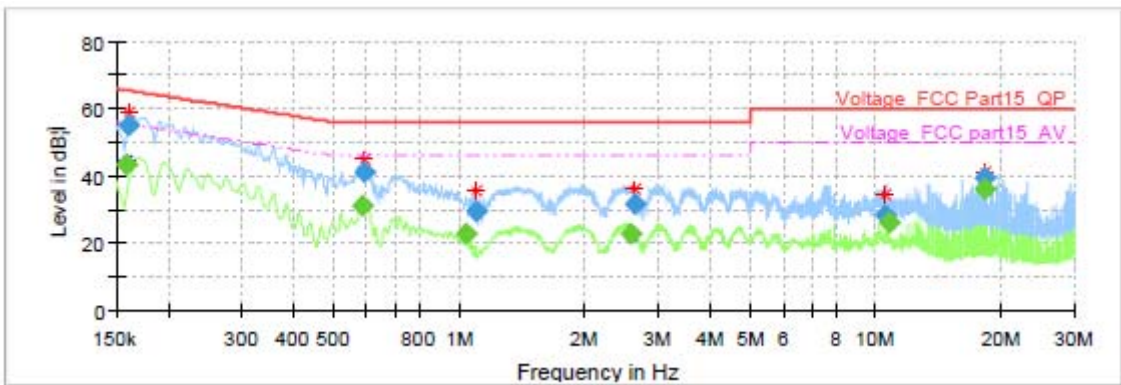

Frequency (MHz)	QuasiPeak (dB; i V)	Average (dB; i V)	Limit (dB; i V)	Margin (dB)	Meas. Time (ms)	Bandwidth (kHz)	Line	Filter	Corr. (dB)
0.159000	---	43.58	55.52	11.94	1000.0	9.000	N	ON	19.7
0.161250	55.26	---	65.40	10.14	1000.0	9.000	N	ON	19.7
0.582000	---	31.17	46.00	14.83	1000.0	9.000	N	ON	19.6
0.588750	41.28	---	56.00	14.72	1000.0	9.000	N	ON	19.6
1.036500	---	22.97	46.00	23.03	1000.0	9.000	N	ON	19.6
1.101750	29.48	---	56.00	26.52	1000.0	9.000	N	ON	19.6
2.580000	---	22.96	46.00	23.04	1000.0	9.000	N	ON	19.6
2.629500	31.62	---	56.00	24.38	1000.0	9.000	N	ON	19.6
10.545000	28.10	---	60.00	31.90	1000.0	9.000	N	ON	19.9
10.792500	---	26.14	50.00	23.86	1000.0	9.000	N	ON	19.9
18.242250	---	35.93	50.00	14.07	1000.0	9.000	N	ON	19.9
18.242250	39.42	---	60.00	20.58	1000.0	9.000	N	ON	19.9

N Line



6. Main Test Instruments

Name	Manufacturer	Type	Serial Number	Calibration Date	Expiration Date
Spectrum Analyzer	R&S	FSV30	100815	2016-12-16	2017-12-15
EMI Test Receiver	R&S	ESCI	100948	2017-05-20	2018-05-19
TRILOG Broadband Antenna	Schwarzbeck	VULB 9163	9163-201	2017-11-18	2020-11-17
Double Ridged Waveguide Horn Antenna	R&S	HF907	100126	2014-12-06	2019-12-05
Loop Antenna	SCHWARZBECK	FMZB1519	1519-047	2017-11-18	2020-11-17
Standard Gain Horn	ETS-Lindgren	3160-09	00102644	2015-01-30	2018-01-29
EMI Test Receiver	R&S	ESCS30	100138	2016-12-16	2017-12-15
LISN	R&S	ENV216	101171	2016-12-16	2019-12-15
Spectrum Analyzer	Agilent	N9010A	MY47191109	2017-05-20	2018-05-19
RF Cable	Agilent	SMA 15cm	0001	2017-08-04	2018-02-03
Software (CE)	ROHDE&SCHW ARZ	EMC32	9.26.0	/	/
Software (RE/RSE)	ROHDE&SCHW ARZ	EMC32	8.52.0	/	/

*****END OF REPORT *****

ANNEX A: EUT Appearance and Test Setup

A.1 EUT Appearance



Front Side



Back Side

a: EUT



b: Adapter

Picture 1 EUT and Accessory

A.2 Test Setup



30M Hz-1GHz



Above 1GHz

Picture 2 Radiated Emission Test Setup



Picture 3 Conducted Emission Test Setup