



RF TEST REPORT

Applicant ZTE Corporation
FCC ID SRQ-MC801A
Product 5G CPE
Model MC801A
Report No. R2112A1085-R2
Issue Date December 31, 2021

TA Technology (Shanghai) Co., Ltd. tested the above equipment in accordance with the requirements in **FCC CFR47 Part 2 (2020)/ FCC CFR 47 Part 24E (2020)**. The test results show that the equipment tested is capable of demonstrating compliance with the requirements as documented in this report.

Prepared by: Peng Tao

Approved by: Kai Xu

TA Technology (Shanghai) Co., Ltd.

No.145, Jintang Rd, Tangzhen Industry Park, Pudong Shanghai, China

TEL: +86-021-50791141/2/3

FAX: +86-021-50791141/2/3-8000



TABLE OF CONTENT

- 1. Test Laboratory4
 - 1.1. Notes of the test report.....4
 - 1.2. Test facility.....4
 - 1.3. Testing Location4
- 2. General Description of Equipment under Test.....5
 - 2.1. Applicant and Manufacturer Information5
 - 2.2. General information5
- 3. Applied Standards.....6
- 4. Test Configuration.....7
- 5. Test Case Results.....9
 - 5.1. RF Power Output and Effective Isotropic Radiated Power9
 - 5.2. Occupied Bandwidth20
 - 5.3. Band Edge Compliance.....33
 - 5.4. Peak-to-Average Power Ratio (PAPR)47
 - 5.5. Frequency Stability51
 - 5.6. Spurious Emissions at Antenna Terminals56
 - 5.7. Radiates Spurious Emission61
- 6. Main Test Instruments66
- ANNEX A: The EUT Appearance.....67
- ANNEX B: Test Setup Photos68

Summary of measurement results

No.	Test Case	Clause in FCC rules	Verdict
1	RF Power Output and Effective Isotropic Radiated Power	2.1046 24.232(c)	PASS
2	Occupied Bandwidth	2.1049	PASS
3	Band Edge Compliance	2.1051 /24.238(a)	PASS
4	Peak-to-Average Power Ratio	24.232/KDB 971168 D01(5.7)	PASS
5	Frequency Stability	2.1055 / 24.235	PASS
6	Spurious Emissions at Antenna Terminals	2.1051 / 24.238(a)	PASS
7	Radiates Spurious Emission	2.1053 / 24.238(a)	PASS
Date of Testing: December 4, 2021 ~ December 25, 2021			
Date of Sample Received: December 1, 2021			
Note: PASS: The EUT complies with the essential requirements in the standard. FAIL: The EUT does not comply with the essential requirements in the standard. All indications of Pass/Fail in this report are opinions expressed by TA Technology (Shanghai) Co., Ltd. based on interpretations and/or observations of test results. Measurement Uncertainties were not taken into account and are published for informational purposes only.			



1. Test Laboratory

1.1. Notes of the test report

This report shall not be reproduced in full or partial, without the written approval of **TA technology (shanghai) co., Ltd.** The results documented in this report apply only to the tested sample, under the conditions and modes of operation as described herein. Measurement Uncertainties were not taken into account and are published for informational purposes only. This report is written to support regulatory compliance of the applicable standards stated above.

1.2. Test facility

FCC (Designation number: CN1179, Test Firm Registration Number: 446626)

TA Technology (Shanghai) Co., Ltd. has been listed on the US Federal Communications Commission list of test facilities recognized to perform measurements.

A2LA (Certificate Number: 3857.01)

TA Technology (Shanghai) Co., Ltd. has been listed by American Association for Laboratory Accreditation to perform measurement.

1.3. Testing Location

Company: TA Technology (Shanghai) Co., Ltd.
Address: No.145, Jintang Rd, Tangzhen Industry Park, Pudong
City: Shanghai
Post code: 201201
Country: P. R. China
Contact: Xu Kai
Telephone: +86-021-50791141/2/3
Fax: +86-021-50791141/2/3-8000
Website: <http://www.ta-shanghai.com>
E-mail: xukai@ta-shanghai.com

2. General Description of Equipment under Test

2.1. Applicant and Manufacturer Information

Applicant	ZTE Corporation
Applicant address	ZTE Plaza, Keji Road South, Hi-Tech, Industrial Park, Nanshan District, Shenzhen, Guangdong, 518057, P.R.China
Manufacturer	ZTE Corporation
Manufacturer address	ZTE Plaza, Keji Road South, Hi-Tech, Industrial Park, Nanshan District, Shenzhen, Guangdong, 518057, P.R.China

2.2. General information

EUT Description			
Model	MC801A		
IMEI	863671043881410		
Hardware Version	MC801AHW-1.0.0		
Software Version	BD_TLCMXMC801AV1.0.0B01		
Power Supply	AC adapter		
Antenna Type	Internal Antenna		
Antenna Gain	2dBi		
Test Mode(s)	WCDMA Band II; LTE Band 2;		
Test Modulation	(WCDMA) BPSK, QPSK, 16QAM; (LTE) QPSK, 16QAM/64QAM		
Maximum E.I.R.P	WCDMA Band II:	25.12 dBm	
	LTE Band 2:	26.32 dBm	
Rated Power Supply Voltage	12V		
Operating Voltage	Minimum: 10.8V Maximum: 13.2V		
Operating Temperature	Lowest: -20°C Highest: +55°C		
Testing Temperature	Lowest: -30°C Highest: +50°C		
Operating Frequency Range(s)	Band	Tx (MHz)	Rx (MHz)
	WCDMA Band II	1850 ~ 1910	1930 ~ 1990
	LTE Band 2	1850 ~ 1910	1930 ~ 1990
EUT Accessory			
Adapter 1	Manufacturer: Shenzhen Ruijing Industrial Co.,Ltd Model: STC-A1215C55-C		
Adapter 2	Manufacturer: Shenzhen Dokocom Energy Technology Co., Ltd. Model: STC-A1215C55-C		
Note: 1. The EUT is sent from the applicant to TA and the information of the EUT is declared by the applicant.			



3. Applied Standards

According to the specifications of the manufacturer, it must comply with the requirements of the following standards:

Test standards:

FCC CFR 47 Part 24E (2020)

FCC CFR47 Part 2 (2020)

Reference standard:

ANSI C63.26 (2015)

KDB 971168 D01 Power Meas License Digital Systems v03r01

4. Test Configuration

Radiated measurements are performed by rotating the EUT in three different orthogonal test planes. EUT stand-up position (Z axis), lie-down position (X, Y axis). Receiver antenna polarization (horizontal and vertical), the worst emission was found in position (Z axis, horizontal polarization) and the worst case was recorded.

All mode and data rates and positions and RB size and modulations were investigated.

Subsequently, only the worst case emissions are reported.

The following testing in WCDMA/LTE is set based on the maximum RF Output Power.

Test modes are chosen to be reported as the worst case configuration below:

Test items	Modes/Modulation
	WCDMA Band II
RF Power Output and Effective Isotropic Radiated Power	RMC HSDPA/HSUPA DC-HSDPA/HSPA+
Occupied Bandwidth	RMC
Band Edge Compliance	RMC
Peak-to-Average Power Ratio	RMC
Frequency Stability	RMC
Spurious Emissions at Antenna Terminals	RMC
Radiates Spurious Emission	RMC

Test modes are chosen to be reported as the worst case configuration below for LTE Band 2:

Test items	Bandwidth (MHz)						Modulation		RB			Test Channel		
	1.4	3	5	10	15	20	QPSK	16QAM 64QAM	1	50%	100%	L	M	H
RF Power Output and Effective Isotropic Radiated Power	○	○	○	○	○	○	○	○	○	○	○	○	○	○
Occupied Bandwidth	○	○	○	○	○	○	○	○	-	-	○	○	○	○
Band Edge Compliance	○	○	○	○	○	○	○	○	○	-	○	○	-	○
Peak-to-Average Power Ratio	○	○	○	○	○	○	○	○	-	-	○	○	○	○



Frequency Stability	O	O	O	O	O	O	O	O	O	-	-	-	O	-
Spurious Emissions at Antenna Terminals	O	O	O	O	O	O	O	-	O	-	-	O	O	O
Radiates Spurious Emission	O	-	O	-	-	O	O	-	O	-	-	-	O	-
Note	1. The mark "O" means that this configuration is chosen for testing. 2. The mark "-" means that this configuration is not testing.													

5. Test Case Results

5.1.RF Power Output and Effective Isotropic Radiated Power

Ambient condition

Temperature	Relative humidity	Pressure
23°C ~25°C	45%~50%	101.5kPa

Methods of Measurement

During the process of the testing, The EUT was connected to the Base Station Simulator with a known loss. The EUT is controlled by the Base Station Simulator test set to ensure max power transmission with proper modulation.

ERP can then be calculated as follows:

$$\text{EIRP (dBm)} = \text{Output Power (dBm)} - \text{Losses (dB)} + \text{Antenna Gain (dBi)}$$

where:dBd refers to gain relative to an ideal dipole.

$$\text{EIRP (dBm)} = \text{ERP (dBm)} + 2.15 \text{ (dB.)}$$

Test Setup

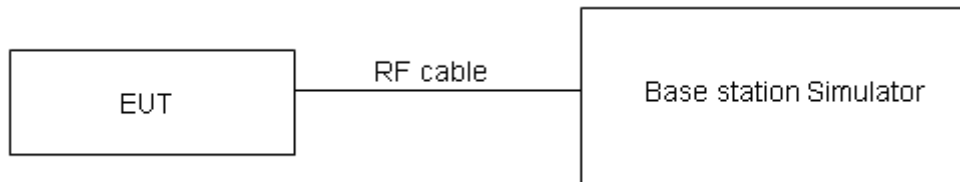

Limits

No specific RF power output requirements in part 2.1046.

Rule Part 24.232(c) Mobile and portable stations are limited to 2 watts EIRP.

Rule Part 24.232(e) Peak transmit power must be measured over any interval of continuous transmission using instrumentation calibrated in terms of an rms-equivalent voltage.

Limit	$\leq 2 \text{ W}$ (33 dBm)
-------	-----------------------------

Measurement Uncertainty

The assessed measurement uncertainty to ensure 95% confidence level for the normal distribution is with the coverage factor $k = 2$, $U = 0.4 \text{ dB}$ for RF power output, $k = 2$, $U = 1.19 \text{ dB}$ for EIRP.

Test Results

WCDMA Band II		Maximum Output Power (dBm)			EIRP (dBm)		
		Channel 9262	Channel 9400	Channel 9538	Channel 9262	Channel 9400	Channel 9538
		1852.4 (MHz)	1880 (MHz)	1907.6 (MHz)	1852.4 (MHz)	1880 (MHz)	1907.6 (MHz)
RMC		22.97	23.12	22.99	24.97	25.12	24.99
HSDPA	Sub - Test 1	22.39	22.54	22.41	24.39	24.54	24.41
	Sub - Test 2	22.38	22.53	22.40	24.38	24.53	24.40
	Sub - Test 3	21.87	22.02	21.89	23.87	24.02	23.89
	Sub - Test 4	21.86	22.01	21.88	23.86	24.01	23.88
HSUPA	Sub - Test 1	21.35	21.50	21.37	23.35	23.50	23.37
	Sub - Test 2	19.34	19.49	19.36	21.34	21.49	21.36
	Sub - Test 3	20.32	20.48	20.35	22.32	22.48	22.35
	Sub - Test 4	19.31	19.47	19.34	21.31	21.47	21.34
	Sub - Test 5	22.80	22.96	22.83	24.80	24.96	24.83
DC-HSDPA	Sub - Test 1	22.31	22.48	22.33	24.31	24.48	24.33
	Sub - Test 2	22.30	22.47	22.32	24.30	24.47	24.32
	Sub - Test 3	21.88	21.96	21.83	23.88	23.96	23.83
	Sub - Test 4	21.87	21.95	21.82	23.87	23.95	23.82
HSPA+	16QAM	20.46	20.63	20.50	22.46	22.63	22.50



LTE Band 2							
Bandwidth (MHz)	UL Channel	RB Size	RB Position	Modulation	Power (dBm)	EIRP (dBm)	Verdict
1.4	18607	1	#0	QPSK	23.21	25.21	PASS
1.4	18607	1	#Mid	QPSK	23.21	25.21	PASS
1.4	18607	1	#Max	QPSK	23.08	25.08	PASS
1.4	18607	3	#0	QPSK	23.10	25.10	PASS
1.4	18607	3	#Mid	QPSK	23.10	25.10	PASS
1.4	18607	3	#Max	QPSK	22.99	24.99	PASS
1.4	18607	6	#0	QPSK	22.24	24.24	PASS
1.4	18607	1	#0	QAM16	22.26	24.26	PASS
1.4	18607	1	#Mid	QAM16	22.25	24.25	PASS
1.4	18607	1	#Max	QAM16	22.16	24.16	PASS
1.4	18607	3	#0	QAM16	22.35	24.35	PASS
1.4	18607	3	#Mid	QAM16	22.35	24.35	PASS
1.4	18607	3	#Max	QAM16	22.28	24.28	PASS
1.4	18607	6	#0	QAM16	21.30	23.30	PASS
1.4	18900	1	#0	QPSK	24.13	26.13	PASS
1.4	18900	1	#Mid	QPSK	24.17	26.17	PASS
1.4	18900	1	#Max	QPSK	24.17	26.17	PASS
1.4	18900	3	#0	QPSK	24.08	26.08	PASS
1.4	18900	3	#Mid	QPSK	24.15	26.15	PASS
1.4	18900	3	#Max	QPSK	24.16	26.16	PASS
1.4	18900	6	#0	QPSK	23.40	25.40	PASS
1.4	18900	1	#0	QAM16	23.35	25.35	PASS
1.4	18900	1	#Mid	QAM16	23.55	25.55	PASS
1.4	18900	1	#Max	QAM16	23.43	25.43	PASS
1.4	18900	3	#0	QAM16	23.29	25.29	PASS
1.4	18900	3	#Mid	QAM16	23.28	25.28	PASS
1.4	18900	3	#Max	QAM16	23.33	25.33	PASS
1.4	18900	6	#0	QAM16	22.41	24.41	PASS
1.4	19193	1	#0	QPSK	23.10	25.10	PASS
1.4	19193	1	#Mid	QPSK	23.26	25.26	PASS
1.4	19193	1	#Max	QPSK	23.22	25.22	PASS
1.4	19193	3	#0	QPSK	23.05	25.05	PASS
1.4	19193	3	#Mid	QPSK	23.04	25.04	PASS
1.4	19193	3	#Max	QPSK	23.09	25.09	PASS
1.4	19193	6	#0	QPSK	22.24	24.24	PASS
1.4	19193	1	#0	QAM16	22.02	24.02	PASS
1.4	19193	1	#Mid	QAM16	22.19	24.19	PASS
1.4	19193	1	#Max	QAM16	22.15	24.15	PASS
1.4	19193	3	#0	QAM16	22.13	24.13	PASS



1.4	19193	3	#Mid	QAM16	22.10	24.10	PASS
1.4	19193	3	#Max	QAM16	22.20	24.20	PASS
1.4	19193	6	#0	QAM16	21.26	23.26	PASS
3	18615	1	#0	QPSK	22.92	24.92	PASS
3	18615	1	#Mid	QPSK	22.93	24.93	PASS
3	18615	1	#Max	QPSK	22.80	24.80	PASS
3	18615	8	#0	QPSK	22.10	24.10	PASS
3	18615	8	#Mid	QPSK	22.13	24.13	PASS
3	18615	8	#Max	QPSK	22.08	24.08	PASS
3	18615	15	#0	QPSK	22.11	24.11	PASS
3	18615	1	#0	QAM16	22.29	24.29	PASS
3	18615	1	#Mid	QAM16	22.28	24.28	PASS
3	18615	1	#Max	QAM16	22.17	24.17	PASS
3	18615	8	#0	QAM16	21.21	23.21	PASS
3	18615	8	#Mid	QAM16	21.19	23.19	PASS
3	18615	8	#Max	QAM16	21.20	23.20	PASS
3	18615	15	#0	QAM16	21.14	23.14	PASS
3	18900	1	#0	QPSK	23.83	25.83	PASS
3	18900	1	#Mid	QPSK	24.20	26.20	PASS
3	18900	1	#Max	QPSK	24.08	26.08	PASS
3	18900	8	#0	QPSK	23.25	25.25	PASS
3	18900	8	#Mid	QPSK	23.33	25.33	PASS
3	18900	8	#Max	QPSK	23.34	25.34	PASS
3	18900	15	#0	QPSK	23.37	25.37	PASS
3	18900	1	#0	QAM16	23.28	25.28	PASS
3	18900	1	#Mid	QAM16	23.44	25.44	PASS
3	18900	1	#Max	QAM16	23.42	25.42	PASS
3	18900	8	#0	QAM16	22.38	24.38	PASS
3	18900	8	#Mid	QAM16	22.39	24.39	PASS
3	18900	8	#Max	QAM16	22.48	24.48	PASS
3	18900	15	#0	QAM16	22.35	24.35	PASS
3	19185	1	#0	QPSK	22.79	24.79	PASS
3	19185	1	#Mid	QPSK	23.07	25.07	PASS
3	19185	1	#Max	QPSK	23.18	25.18	PASS
3	19185	8	#0	QPSK	21.97	23.97	PASS
3	19185	8	#Mid	QPSK	21.96	23.96	PASS
3	19185	8	#Max	QPSK	22.19	24.19	PASS
3	19185	15	#0	QPSK	22.08	24.08	PASS
3	19185	1	#0	QAM16	21.74	23.74	PASS
3	19185	1	#Mid	QAM16	21.99	23.99	PASS
3	19185	1	#Max	QAM16	22.13	24.13	PASS
3	19185	8	#0	QAM16	21.01	23.01	PASS
3	19185	8	#Mid	QAM16	21.00	23.00	PASS



3	19185	8	#Max	QAM16	21.23	23.23	PASS
3	19185	15	#0	QAM16	21.13	23.13	PASS
5	18625	1	#0	QPSK	22.78	24.78	PASS
5	18625	1	#Mid	QPSK	22.90	24.90	PASS
5	18625	1	#Max	QPSK	22.75	24.75	PASS
5	18625	12	#0	QPSK	22.00	24.00	PASS
5	18625	12	#Mid	QPSK	21.98	23.98	PASS
5	18625	12	#Max	QPSK	21.95	23.95	PASS
5	18625	25	#0	QPSK	21.99	23.99	PASS
5	18625	1	#0	QAM16	22.14	24.14	PASS
5	18625	1	#Mid	QAM16	22.26	24.26	PASS
5	18625	1	#Max	QAM16	22.03	24.03	PASS
5	18625	12	#0	QAM16	21.02	23.02	PASS
5	18625	12	#Mid	QAM16	21.07	23.07	PASS
5	18625	12	#Max	QAM16	21.05	23.05	PASS
5	18625	25	#0	QAM16	21.02	23.02	PASS
5	18900	1	#0	QPSK	23.77	25.77	PASS
5	18900	1	#Mid	QPSK	24.22	26.22	PASS
5	18900	1	#Max	QPSK	23.94	25.94	PASS
5	18900	12	#0	QPSK	23.11	25.11	PASS
5	18900	12	#Mid	QPSK	23.18	25.18	PASS
5	18900	12	#Max	QPSK	23.15	25.15	PASS
5	18900	25	#0	QPSK	23.26	25.26	PASS
5	18900	1	#0	QAM16	23.01	25.01	PASS
5	18900	1	#Mid	QAM16	23.48	25.48	PASS
5	18900	1	#Max	QAM16	23.25	25.25	PASS
5	18900	12	#0	QAM16	22.12	24.12	PASS
5	18900	12	#Mid	QAM16	22.20	24.20	PASS
5	18900	12	#Max	QAM16	22.37	24.37	PASS
5	18900	25	#0	QAM16	22.21	24.21	PASS
5	19175	1	#0	QPSK	22.47	24.47	PASS
5	19175	1	#Mid	QPSK	22.82	24.82	PASS
5	19175	1	#Max	QPSK	22.86	24.86	PASS
5	19175	12	#0	QPSK	21.78	23.78	PASS
5	19175	12	#Mid	QPSK	21.78	23.78	PASS
5	19175	12	#Max	QPSK	22.01	24.01	PASS
5	19175	25	#0	QPSK	21.89	23.89	PASS
5	19175	1	#0	QAM16	21.80	23.80	PASS
5	19175	1	#Mid	QAM16	22.19	24.19	PASS
5	19175	1	#Max	QAM16	22.24	24.24	PASS
5	19175	12	#0	QAM16	19.96	21.96	PASS
5	19175	12	#Mid	QAM16	19.95	21.95	PASS
5	19175	12	#Max	QAM16	20.26	22.26	PASS



5	19175	25	#0	QAM16	20.93	22.93	PASS
10	18650	1	#0	QPSK	22.13	24.13	PASS
10	18650	1	#Mid	QPSK	22.67	24.67	PASS
10	18650	1	#Max	QPSK	22.38	24.38	PASS
10	18650	25	#0	QPSK	21.66	23.66	PASS
10	18650	25	#Mid	QPSK	21.67	23.67	PASS
10	18650	25	#Max	QPSK	21.80	23.80	PASS
10	18650	50	#0	QPSK	21.77	23.77	PASS
10	18650	1	#0	QAM16	21.48	23.48	PASS
10	18650	1	#Mid	QAM16	22.10	24.10	PASS
10	18650	1	#Max	QAM16	21.79	23.79	PASS
10	18650	25	#0	QAM16	20.80	22.80	PASS
10	18650	25	#Mid	QAM16	20.79	22.79	PASS
10	18650	25	#Max	QAM16	20.96	22.96	PASS
10	18650	50	#0	QAM16	20.80	22.80	PASS
10	18900	1	#0	QPSK	22.85	24.85	PASS
10	18900	1	#Mid	QPSK	23.94	25.94	PASS
10	18900	1	#Max	QPSK	23.09	25.09	PASS
10	18900	25	#0	QPSK	22.82	24.82	PASS
10	18900	25	#Mid	QPSK	22.75	24.75	PASS
10	18900	25	#Max	QPSK	22.93	24.93	PASS
10	18900	50	#0	QPSK	22.85	24.85	PASS
10	18900	1	#0	QAM16	22.16	24.16	PASS
10	18900	1	#Mid	QAM16	23.33	25.33	PASS
10	18900	1	#Max	QAM16	22.42	24.42	PASS
10	18900	25	#0	QAM16	21.88	23.88	PASS
10	18900	25	#Mid	QAM16	21.88	23.88	PASS
10	18900	25	#Max	QAM16	22.08	24.08	PASS
10	18900	50	#0	QAM16	21.94	23.94	PASS
10	19150	1	#0	QPSK	22.90	24.90	PASS
10	19150	1	#Mid	QPSK	22.80	24.80	PASS
10	19150	1	#Max	QPSK	23.07	25.07	PASS
10	19150	25	#0	QPSK	21.76	23.76	PASS
10	19150	25	#Mid	QPSK	21.76	23.76	PASS
10	19150	25	#Max	QPSK	21.73	23.73	PASS
10	19150	50	#0	QPSK	21.75	23.75	PASS
10	19150	1	#0	QAM16	22.09	24.09	PASS
10	19150	1	#Mid	QAM16	21.74	23.74	PASS
10	19150	1	#Max	QAM16	21.98	23.98	PASS
10	19150	25	#0	QAM16	20.84	22.84	PASS
10	19150	25	#Mid	QAM16	20.84	22.84	PASS
10	19150	25	#Max	QAM16	20.77	22.77	PASS
10	19150	50	#0	QAM16	20.81	22.81	PASS



15	18675	1	#0	QPSK	22.67	24.67	PASS
15	18675	1	#Mid	QPSK	23.00	25.00	PASS
15	18675	1	#Max	QPSK	23.23	25.23	PASS
15	18675	36	#0	QPSK	21.97	23.97	PASS
15	18675	36	#Mid	QPSK	21.97	23.97	PASS
15	18675	36	#Max	QPSK	22.35	24.35	PASS
15	18675	75	#0	QPSK	22.16	24.16	PASS
15	18675	1	#0	QAM16	21.98	23.98	PASS
15	18675	1	#Mid	QAM16	22.28	24.28	PASS
15	18675	1	#Max	QAM16	22.58	24.58	PASS
15	18675	36	#0	QAM16	21.10	23.10	PASS
15	18675	36	#Mid	QAM16	21.04	23.04	PASS
15	18675	36	#Max	QAM16	21.39	23.39	PASS
15	18675	75	#0	QAM16	21.34	23.34	PASS
15	18900	1	#0	QPSK	23.39	25.39	PASS
15	18900	1	#Mid	QPSK	23.87	25.87	PASS
15	18900	1	#Max	QPSK	23.28	25.28	PASS
15	18900	36	#0	QPSK	22.77	24.77	PASS
15	18900	36	#Mid	QPSK	22.71	24.71	PASS
15	18900	36	#Max	QPSK	22.87	24.87	PASS
15	18900	75	#0	QPSK	22.85	24.85	PASS
15	18900	1	#0	QAM16	22.67	24.67	PASS
15	18900	1	#Mid	QAM16	23.25	25.25	PASS
15	18900	1	#Max	QAM16	22.59	24.59	PASS
15	18900	36	#0	QAM16	21.77	23.77	PASS
15	18900	36	#Mid	QAM16	21.82	23.82	PASS
15	18900	36	#Max	QAM16	21.99	23.99	PASS
15	18900	75	#0	QAM16	21.91	23.91	PASS
15	19125	1	#0	QPSK	22.63	24.63	PASS
15	19125	1	#Mid	QPSK	22.91	24.91	PASS
15	19125	1	#Max	QPSK	22.84	24.84	PASS
15	19125	36	#0	QPSK	21.96	23.96	PASS
15	19125	36	#Mid	QPSK	21.99	23.99	PASS
15	19125	36	#Max	QPSK	21.77	23.77	PASS
15	19125	75	#0	QPSK	22.01	24.01	PASS
15	19125	1	#0	QAM16	21.67	23.67	PASS
15	19125	1	#Mid	QAM16	21.86	23.86	PASS
15	19125	1	#Max	QAM16	21.88	23.88	PASS
15	19125	36	#0	QAM16	21.02	23.02	PASS
15	19125	36	#Mid	QAM16	21.04	23.04	PASS
15	19125	36	#Max	QAM16	20.81	22.81	PASS
15	19125	75	#0	QAM16	21.09	23.09	PASS
20	18700	1	#0	QPSK	22.92	24.92	PASS



20	18700	1	#Mid	QPSK	23.11	25.11	PASS
20	18700	1	#Max	QPSK	23.24	25.24	PASS
20	18700	50	#0	QPSK	21.74	23.74	PASS
20	18700	50	#Mid	QPSK	21.74	23.74	PASS
20	18700	50	#Max	QPSK	22.25	24.25	PASS
20	18700	100	#0	QPSK	22.03	24.03	PASS
20	18700	1	#0	QAM16	22.19	24.19	PASS
20	18700	1	#Mid	QAM16	22.31	24.31	PASS
20	18700	1	#Max	QAM16	22.48	24.48	PASS
20	18700	50	#0	QAM16	20.78	22.78	PASS
20	18700	50	#Mid	QAM16	20.79	22.79	PASS
20	18700	50	#Max	QAM16	21.32	23.32	PASS
20	18700	100	#0	QAM16	21.03	23.03	PASS
20	18900	1	#0	QPSK	23.79	25.79	PASS
20	18900	1	#Mid	QPSK	24.32	26.32	PASS
20	18900	1	#Max	QPSK	22.69	24.69	PASS
20	18900	50	#0	QPSK	22.99	24.99	PASS
20	18900	50	#Mid	QPSK	22.99	24.99	PASS
20	18900	50	#Max	QPSK	22.50	24.50	PASS
20	18900	100	#0	QPSK	22.76	24.76	PASS
20	18900	1	#0	QAM16	22.70	24.70	PASS
20	18900	1	#Mid	QAM16	23.30	25.30	PASS
20	18900	1	#Max	QAM16	21.59	23.59	PASS
20	18900	50	#0	QAM16	22.01	24.01	PASS
20	18900	50	#Mid	QAM16	22.01	24.01	PASS
20	18900	50	#Max	QAM16	21.54	23.54	PASS
20	18900	100	#0	QAM16	21.84	23.84	PASS
20	19100	1	#0	QPSK	22.90	24.90	PASS
20	19100	1	#Mid	QPSK	22.37	24.37	PASS
20	19100	1	#Max	QPSK	21.81	23.81	PASS
20	19100	50	#0	QPSK	21.57	23.57	PASS
20	19100	50	#Mid	QPSK	21.50	23.50	PASS
20	19100	50	#Max	QPSK	20.99	22.99	PASS
20	19100	100	#0	QPSK	21.39	23.39	PASS
20	19100	1	#0	QAM16	22.16	24.16	PASS
20	19100	1	#Mid	QAM16	21.65	23.65	PASS
20	19100	1	#Max	QAM16	21.46	23.46	PASS
20	19100	50	#0	QAM16	21.03	23.03	PASS
20	19100	50	#Mid	QAM16	20.98	22.98	PASS
20	19100	50	#Max	QAM16	20.74	22.74	PASS
20	19100	100	#0	QAM16	20.97	22.97	PASS
1.4	18607	1	#0	QAM64	20.63	22.63	PASS
1.4	18607	1	#Mid	QAM64	20.67	22.67	PASS



1.4	18607	1	#Max	QAM64	20.53	22.53	PASS
1.4	18607	3	#0	QAM64	20.73	22.73	PASS
1.4	18607	3	#Mid	QAM64	20.76	22.76	PASS
1.4	18607	3	#Max	QAM64	20.70	22.70	PASS
1.4	18607	6	#0	QAM64	19.69	21.69	PASS
1.4	18900	1	#0	QAM64	21.90	23.90	PASS
1.4	18900	1	#Mid	QAM64	21.85	23.85	PASS
1.4	18900	1	#Max	QAM64	21.96	23.96	PASS
1.4	18900	3	#0	QAM64	21.76	23.76	PASS
1.4	18900	3	#Mid	QAM64	21.68	23.68	PASS
1.4	18900	3	#Max	QAM64	21.80	23.80	PASS
1.4	18900	6	#0	QAM64	20.85	22.85	PASS
1.4	19193	1	#0	QAM64	20.33	22.33	PASS
1.4	19193	1	#Mid	QAM64	20.52	22.52	PASS
1.4	19193	1	#Max	QAM64	20.51	22.51	PASS
1.4	19193	3	#0	QAM64	20.46	22.46	PASS
1.4	19193	3	#Mid	QAM64	20.45	22.45	PASS
1.4	19193	3	#Max	QAM64	20.50	22.50	PASS
1.4	19193	6	#0	QAM64	19.58	21.58	PASS
3	18615	1	#0	QAM64	20.79	22.79	PASS
3	18615	1	#Mid	QAM64	20.76	22.76	PASS
3	18615	1	#Max	QAM64	20.75	22.75	PASS
3	18615	8	#0	QAM64	19.68	21.68	PASS
3	18615	8	#Mid	QAM64	19.68	21.68	PASS
3	18615	8	#Max	QAM64	19.61	21.61	PASS
3	18615	15	#0	QAM64	19.62	21.62	PASS
3	18900	1	#0	QAM64	21.75	23.75	PASS
3	18900	1	#Mid	QAM64	22.07	24.07	PASS
3	18900	1	#Max	QAM64	21.87	23.87	PASS
3	18900	8	#0	QAM64	20.93	22.93	PASS
3	18900	8	#Mid	QAM64	20.93	22.93	PASS
3	18900	8	#Max	QAM64	21.01	23.01	PASS
3	18900	15	#0	QAM64	20.87	22.87	PASS
3	19185	1	#0	QAM64	20.16	22.16	PASS
3	19185	1	#Mid	QAM64	20.45	22.45	PASS
3	19185	1	#Max	QAM64	20.53	22.53	PASS
3	19185	8	#0	QAM64	19.41	21.41	PASS
3	19185	8	#Mid	QAM64	19.41	21.41	PASS
3	19185	8	#Max	QAM64	19.66	21.66	PASS
3	19185	15	#0	QAM64	19.53	21.53	PASS
5	18625	1	#0	QAM64	21.27	23.27	PASS
5	18625	1	#Mid	QAM64	21.37	23.37	PASS
5	18625	1	#Max	QAM64	21.14	23.14	PASS



5	18625	12	#0	QAM64	20.51	22.51	PASS
5	18625	12	#Mid	QAM64	20.53	22.53	PASS
5	18625	12	#Max	QAM64	20.48	22.48	PASS
5	18625	25	#0	QAM64	20.49	22.49	PASS
5	18900	1	#0	QAM64	22.40	24.40	PASS
5	18900	1	#Mid	QAM64	22.65	24.65	PASS
5	18900	1	#Max	QAM64	22.53	24.53	PASS
5	18900	12	#0	QAM64	21.79	23.79	PASS
5	18900	12	#Mid	QAM64	21.79	23.79	PASS
5	18900	12	#Max	QAM64	21.83	23.83	PASS
5	18900	25	#0	QAM64	21.77	23.77	PASS
5	19175	1	#0	QAM64	21.03	23.03	PASS
5	19175	1	#Mid	QAM64	21.36	23.36	PASS
5	19175	1	#Max	QAM64	21.46	23.46	PASS
5	19175	12	#0	QAM64	20.26	22.26	PASS
5	19175	12	#Mid	QAM64	20.29	22.29	PASS
5	19175	12	#Max	QAM64	20.53	22.53	PASS
5	19175	25	#0	QAM64	20.36	22.36	PASS
10	18650	1	#0	QAM64	20.14	22.14	PASS
10	18650	1	#Mid	QAM64	20.72	22.72	PASS
10	18650	1	#Max	QAM64	20.37	22.37	PASS
10	18650	25	#0	QAM64	19.43	21.43	PASS
10	18650	25	#Mid	QAM64	19.43	21.43	PASS
10	18650	25	#Max	QAM64	19.52	21.52	PASS
10	18650	50	#0	QAM64	19.38	21.38	PASS
10	18900	1	#0	QAM64	20.82	22.82	PASS
10	18900	1	#Mid	QAM64	22.05	24.05	PASS
10	18900	1	#Max	QAM64	20.99	22.99	PASS
10	18900	25	#0	QAM64	20.60	22.60	PASS
10	18900	25	#Mid	QAM64	20.60	22.60	PASS
10	18900	25	#Max	QAM64	20.72	22.72	PASS
10	18900	50	#0	QAM64	20.62	22.62	PASS
10	19150	1	#0	QAM64	20.94	22.94	PASS
10	19150	1	#Mid	QAM64	20.31	22.31	PASS
10	19150	1	#Max	QAM64	20.57	22.57	PASS
10	19150	25	#0	QAM64	19.48	21.48	PASS
10	19150	25	#Mid	QAM64	19.43	21.43	PASS
10	19150	25	#Max	QAM64	19.36	21.36	PASS
10	19150	50	#0	QAM64	19.43	21.43	PASS
15	18675	1	#0	QAM64	20.78	22.78	PASS
15	18675	1	#Mid	QAM64	21.03	23.03	PASS
15	18675	1	#Max	QAM64	21.35	23.35	PASS
15	18675	36	#0	QAM64	19.74	21.74	PASS



15	18675	36	#Mid	QAM64	19.75	21.75	PASS
15	18675	36	#Max	QAM64	20.23	22.23	PASS
15	18675	75	#0	QAM64	19.97	21.97	PASS
15	18900	1	#0	QAM64	21.44	23.44	PASS
15	18900	1	#Mid	QAM64	22.04	24.04	PASS
15	18900	1	#Max	QAM64	21.25	23.25	PASS
15	18900	36	#0	QAM64	20.61	22.61	PASS
15	18900	36	#Mid	QAM64	20.50	22.50	PASS
15	18900	36	#Max	QAM64	20.67	22.67	PASS
15	18900	75	#0	QAM64	20.66	22.66	PASS
15	19125	1	#0	QAM64	20.40	22.40	PASS
15	19125	1	#Mid	QAM64	20.63	22.63	PASS
15	19125	1	#Max	QAM64	20.57	22.57	PASS
15	19125	36	#0	QAM64	20.01	22.01	PASS
15	19125	36	#Mid	QAM64	20.03	22.03	PASS
15	19125	36	#Max	QAM64	19.47	21.47	PASS
15	19125	75	#0	QAM64	19.78	21.78	PASS
20	18700	1	#0	QAM64	21.07	23.07	PASS
20	18700	1	#Mid	QAM64	21.18	23.18	PASS
20	18700	1	#Max	QAM64	21.31	23.31	PASS
20	18700	50	#0	QAM64	19.65	21.65	PASS
20	18700	50	#Mid	QAM64	19.71	21.71	PASS
20	18700	50	#Max	QAM64	20.12	22.12	PASS
20	18700	100	#0	QAM64	19.84	21.84	PASS
20	18900	1	#0	QAM64	21.21	23.21	PASS
20	18900	1	#Mid	QAM64	21.73	23.73	PASS
20	18900	1	#Max	QAM64	20.76	22.76	PASS
20	18900	50	#0	QAM64	20.30	22.30	PASS
20	18900	50	#Mid	QAM64	20.30	22.30	PASS
20	18900	50	#Max	QAM64	20.37	22.37	PASS
20	18900	100	#0	QAM64	20.38	22.38	PASS
20	19100	1	#0	QAM64	20.96	22.96	PASS
20	19100	1	#Mid	QAM64	20.73	22.73	PASS
20	19100	1	#Max	QAM64	20.24	22.24	PASS
20	19100	50	#0	QAM64	19.96	21.96	PASS
20	19100	50	#Mid	QAM64	20.00	22.00	PASS
20	19100	50	#Max	QAM64	19.51	21.51	PASS
20	19100	100	#0	QAM64	19.71	21.71	PASS

5.2.Occupied Bandwidth

Ambient condition

Temperature	Relative humidity	Pressure
23°C ~25°C	45%~50%	101.5kPa

Method of Measurement

The EUT was connected to Spectrum Analyzer and Base Station Simulator via power Splitter. The occupied bandwidth is measured using spectrum analyzer.

RBW is set to $\geq 1\%EBW$, VBW is set to 3x RBW.

99% power and -26dBc occupied bandwidths are recorded. Spectrum analyzer plots are included on the following pages.

Test Setup

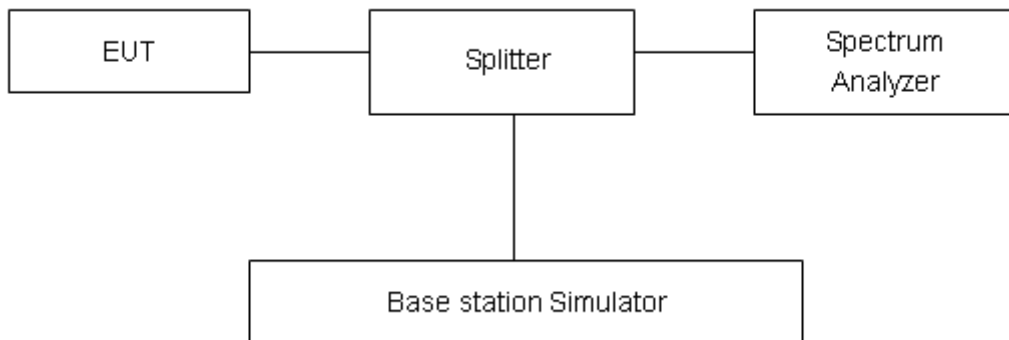

Limits

No specific occupied bandwidth requirements in part 2.1049.

Measurement Uncertainty

The assessed measurement uncertainty to ensure 95% confidence level for the normal distribution is with the coverage factor $k = 2$, $U = 624\text{Hz}$.



Test Result

Mode	Channel	Frequency (MHz)	99% Power Bandwidth (MHz)	-26dBc Bandwidth(MHz)
WCDMA Band II (RMC)	9262	1852.4	4.1589	4.742
	9400	1880	4.1449	4.713
	9538	1907.6	4.1539	4.724

LTE Band 2						
RB	Modulation	Bandwidth (MHz)	Channel	Frequency (MHz)	99% Power Bandwidth(MHz)	-26dBc Bandwidth(MHz)
100%	QPSK	1.4	18607	1850.7	1.0920	1.238
			18900	1880.0	1.0930	1.236
			19193	1909.3	1.0900	1.244
		3	18615	1851.5	2.6970	3.019
			18900	1880	2.7110	3.040
			19185	1908.5	2.7040	2.977
		5	18625	1852.5	4.5230	4.944
			18900	1880	4.5090	4.924
			19175	1907.5	4.5030	4.961
		10	18650	1855	8.9970	9.753
			18900	1880	8.9510	9.703
			19150	1905	8.9510	9.707
		15	18675	1857.5	13.4780	14.690
			18900	1880	13.4480	14.569
			19125	1902.5	13.3980	14.622
		20	18700	1860	17.9060	19.494
			18900	1880	17.9480	19.558
			19100	1900	17.9370	19.348
	16QAM	1.4	18607	1850.7	1.0960	1.228
			18900	1880.0	1.0920	1.232
			19193	1909.3	1.0880	1.220
		3	18615	1851.5	2.7010	2.980
			18900	1880	2.7040	2.993
			19185	1908.5	2.6970	3.008
5		18625	1852.5	4.5070	4.977	
		18900	1880	4.5420	4.969	
		19175	1907.5	4.5080	4.995	



		10	18650	1855	8.9730	9.729
			18900	1880	8.9530	9.751
			19150	1905	8.9510	9.731
		15	18675	1857.5	13.4840	14.654
			18900	1880	13.4400	14.564
			19125	1902.5	13.4640	14.382
		20	18700	1860	17.9100	19.387
			18900	1880	17.9280	19.470
			19100	1900	17.9470	19.553
	64QAM	1.4	18607	1850.7	1.0970	1.233
			18900	1880.0	1.0930	1.245
			19193	1909.3	1.0910	1.230
		3	18615	1851.5	2.7180	2.983
			18900	1880	2.6960	3.008
			19185	1908.5	2.6920	3.011
		5	18625	1852.5	4.5150	4.956
			18900	1880	4.5160	4.945
			19175	1907.5	4.5250	4.943
		10	18650	1855	8.9710	9.755
			18900	1880	8.9690	9.664
			19150	1905	8.9640	9.738
		15	18675	1857.5	13.4450	14.590
			18900	1880	13.4510	14.580
			19125	1902.5	13.4680	14.565
20	18700	1860	17.9050	19.375		
	18900	1880	17.9560	19.410		
	19100	1900	17.8980	19.314		

WCDMA Band II RMC CH-LOW



WCDMA Band II RMC CH-Middle



WCDMA Band II RMC CH-High



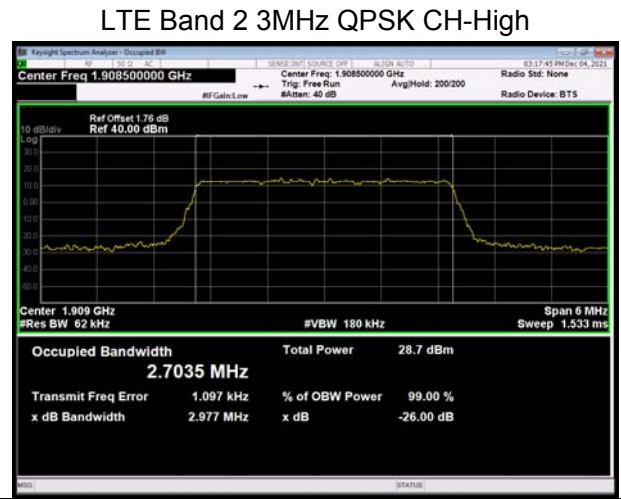
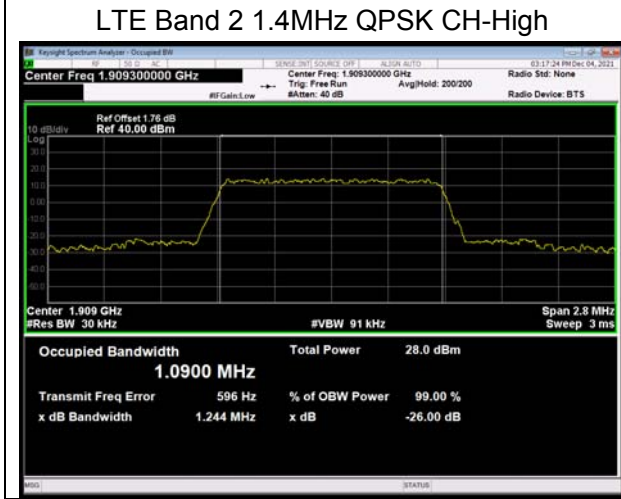
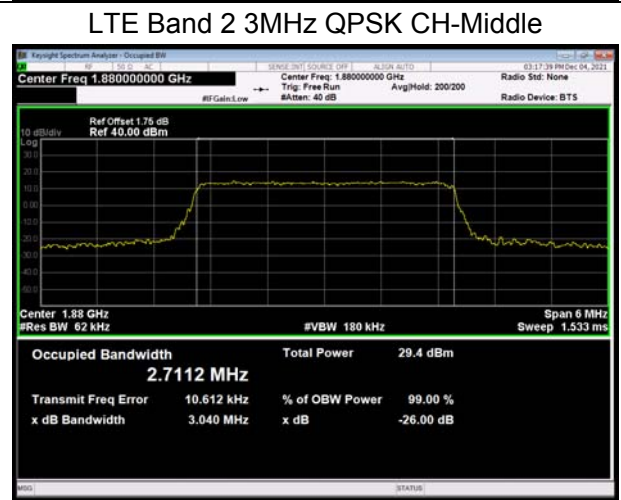
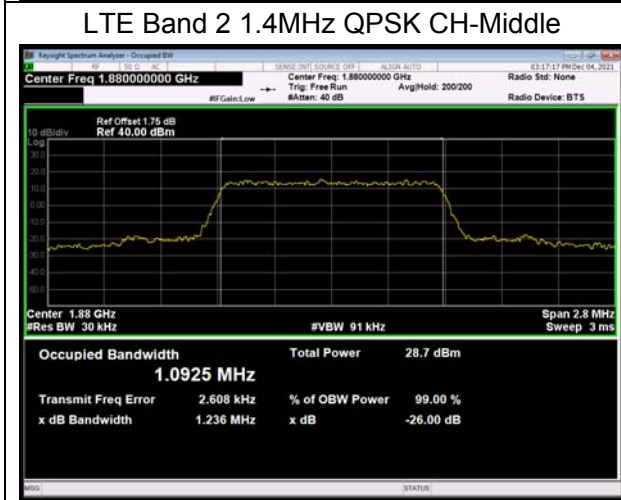
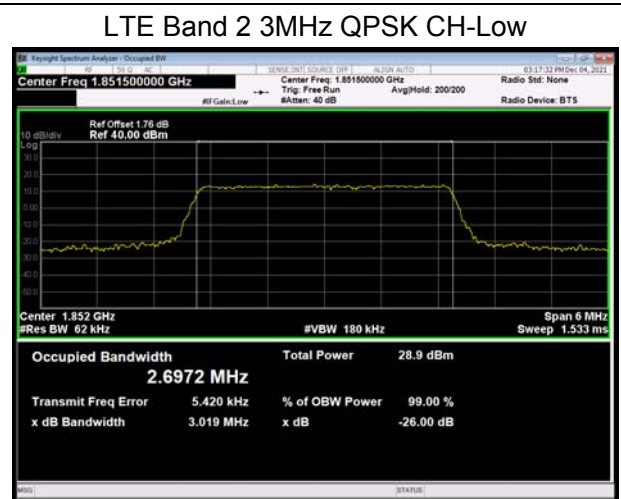
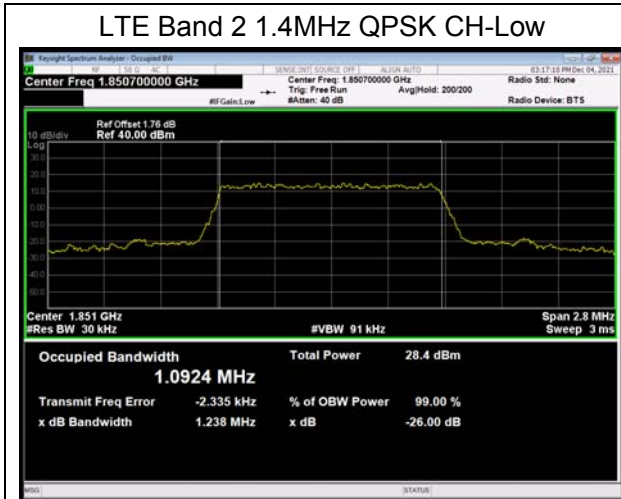



LTE Band 2 5MHz QPSK CH-Low

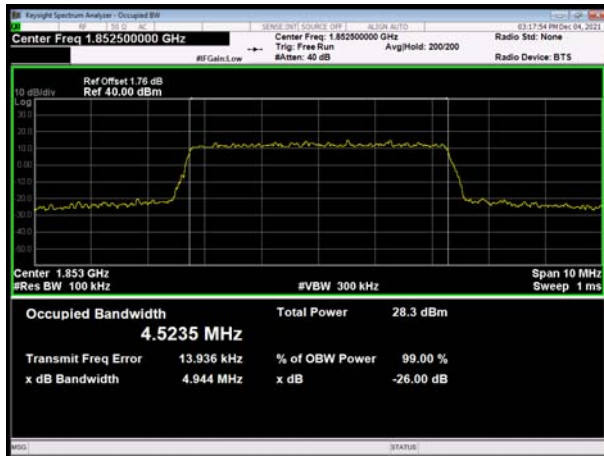

LTE Band 2 10MHz QPSK CH-Low

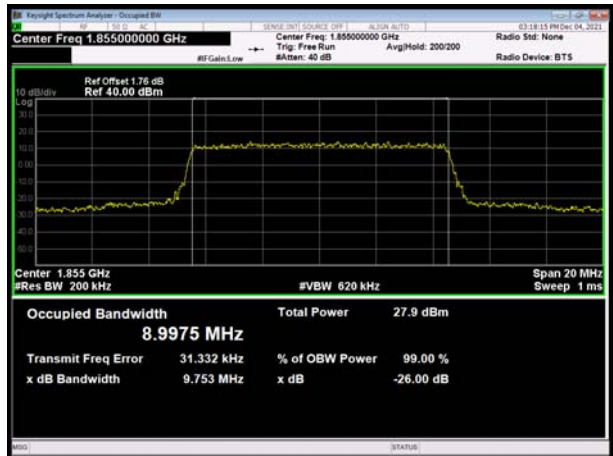

LTE Band 2 5MHz QPSK CH-Middle



LTE Band 2 10MHz QPSK CH-Middle



LTE Band 2 5MHz QPSK CH-High



LTE Band 2 10MHz QPSK CH-High

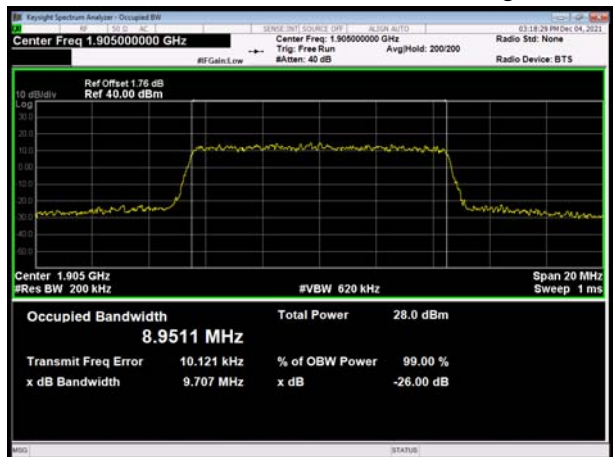

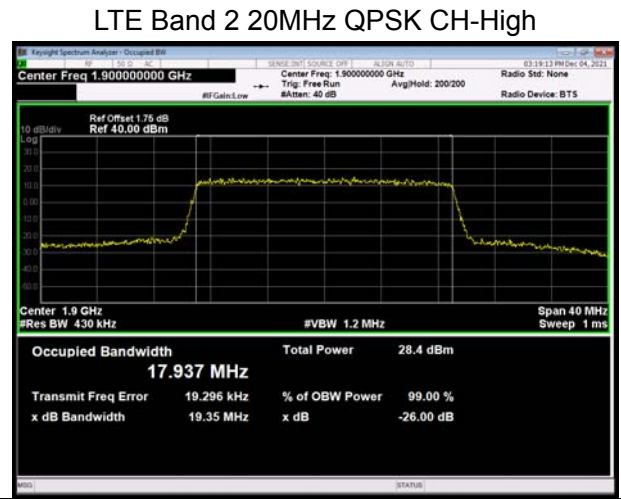
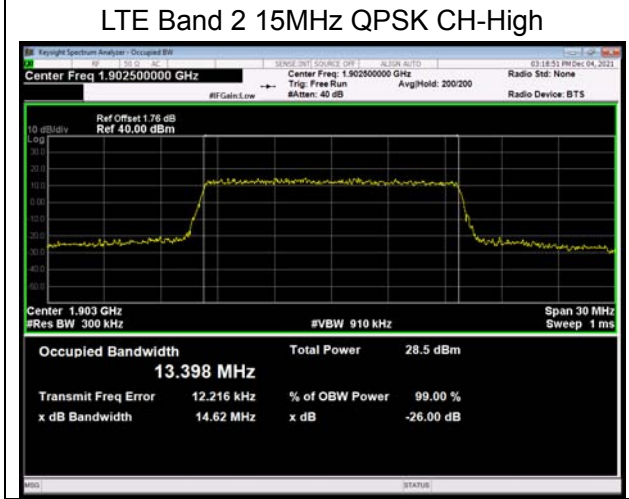
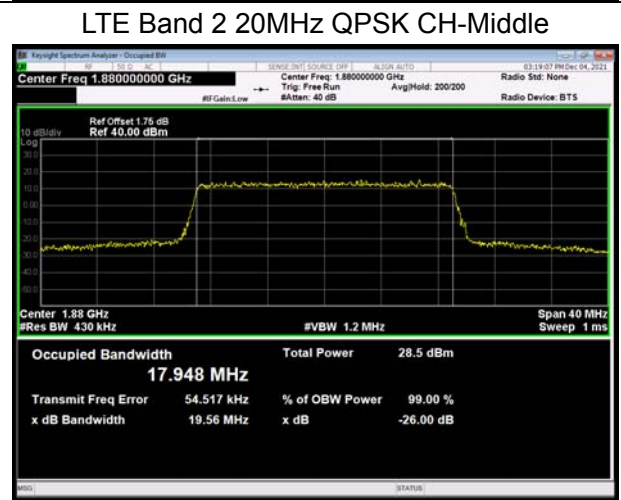
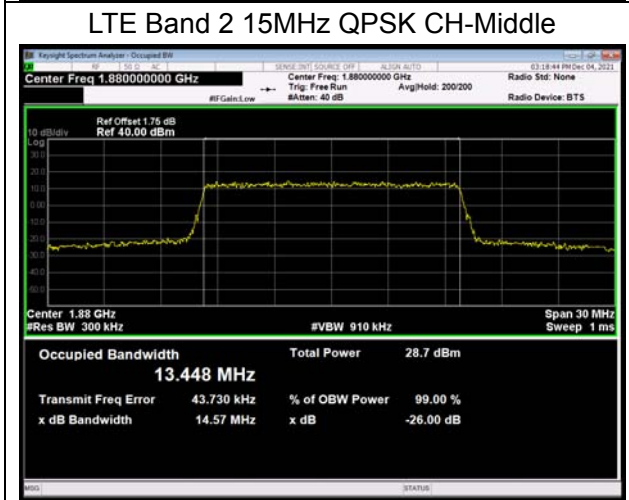
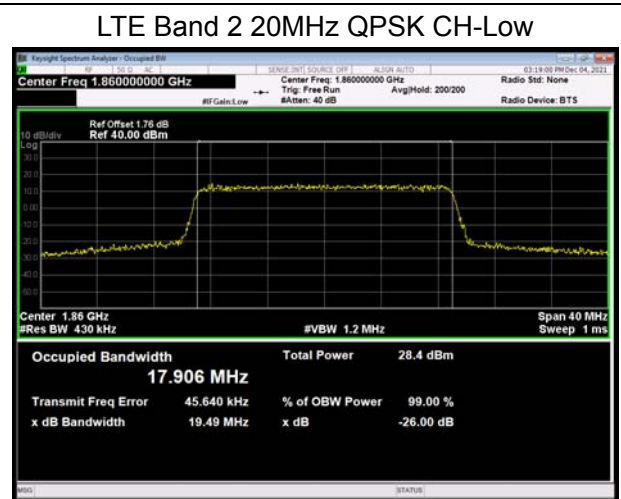
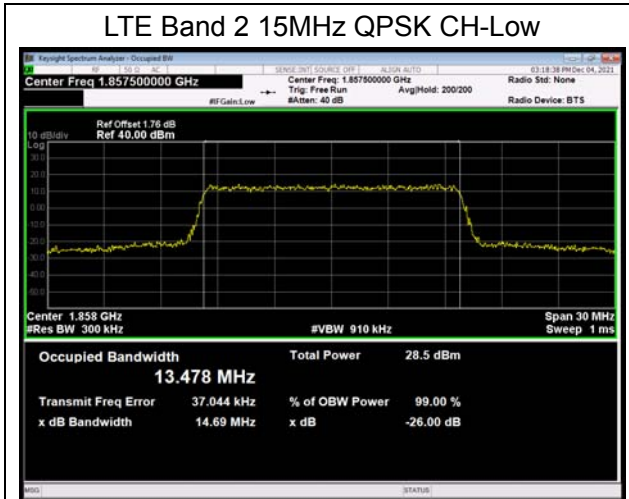

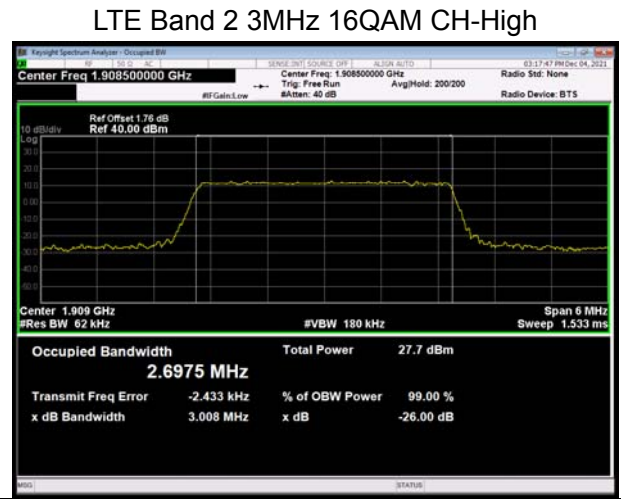
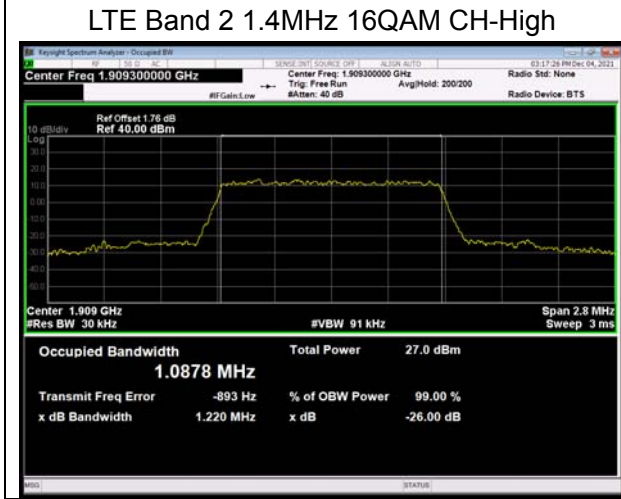
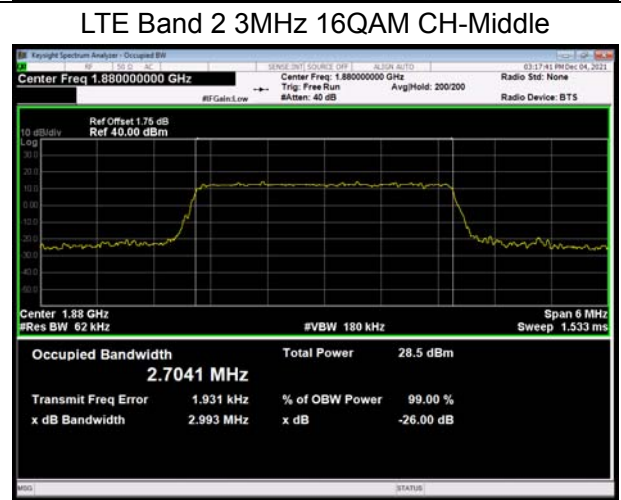
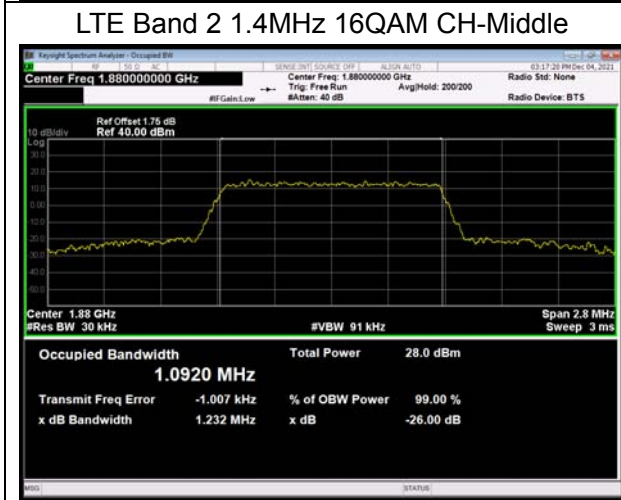
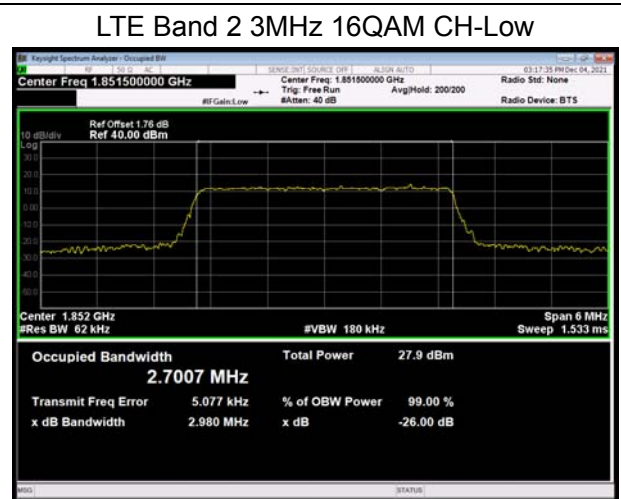
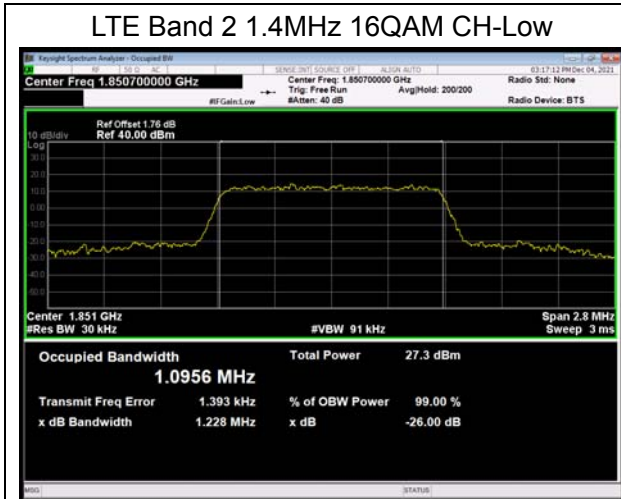

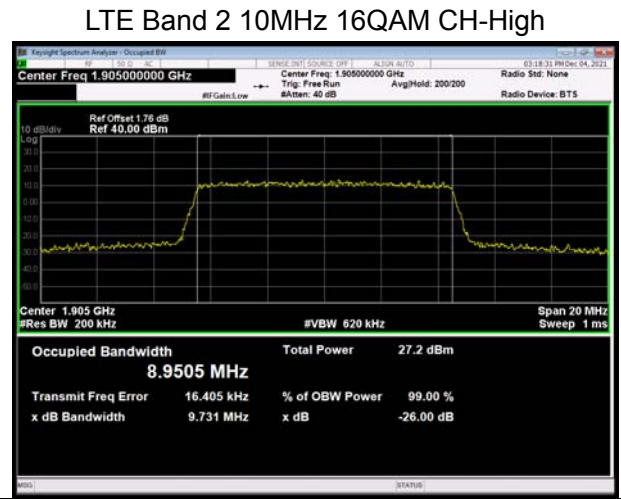
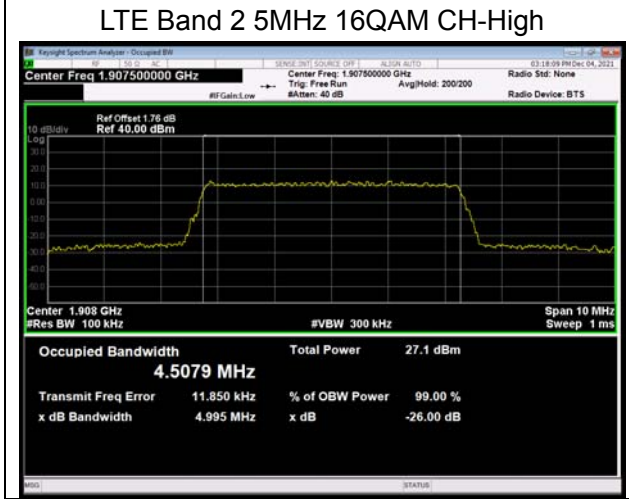
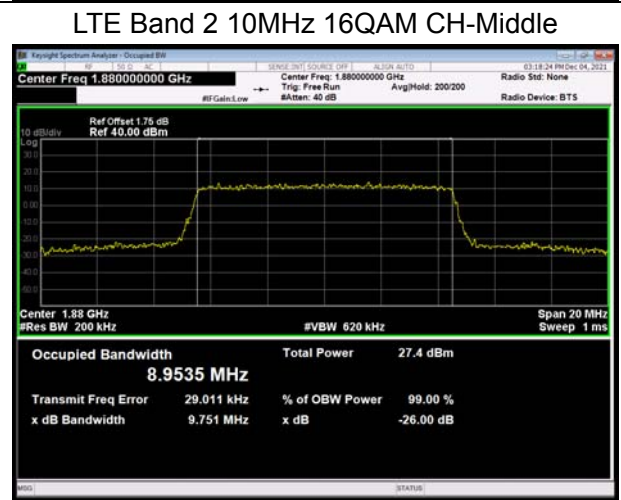
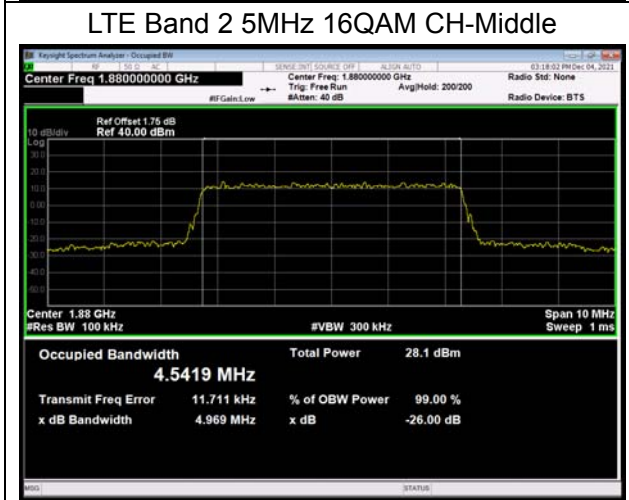
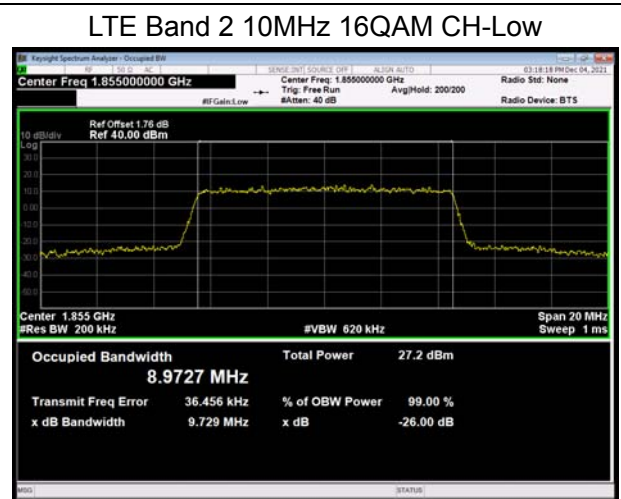
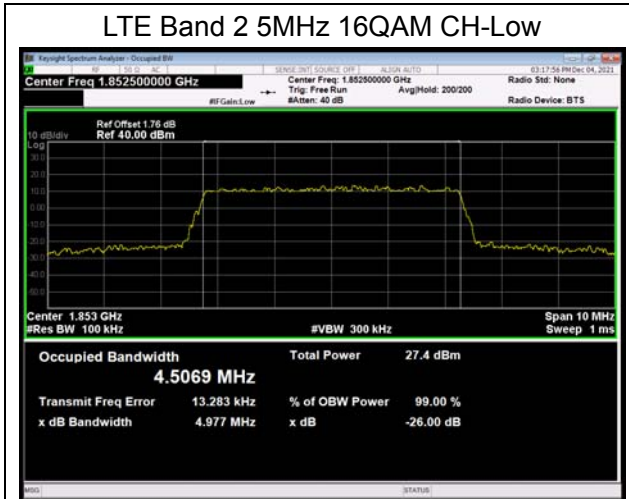

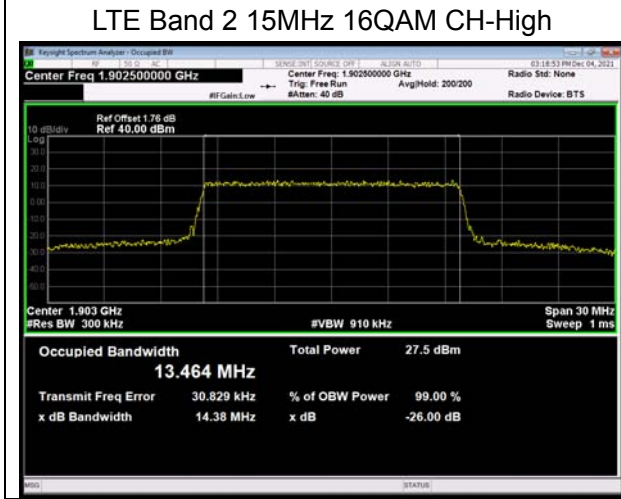
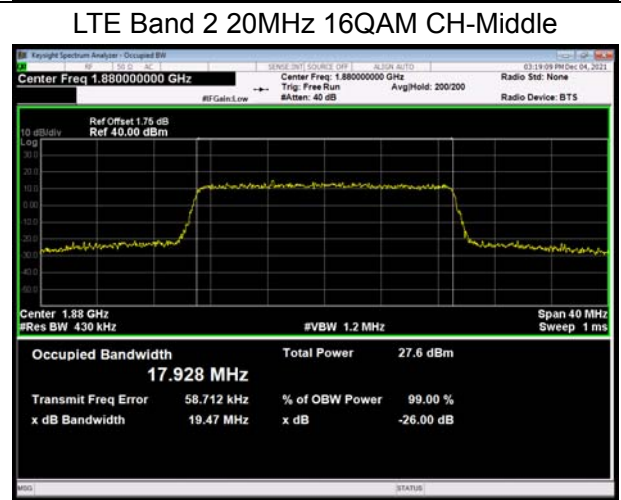
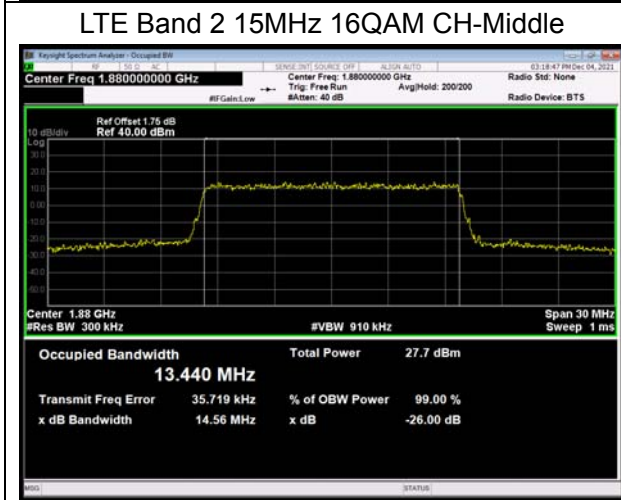
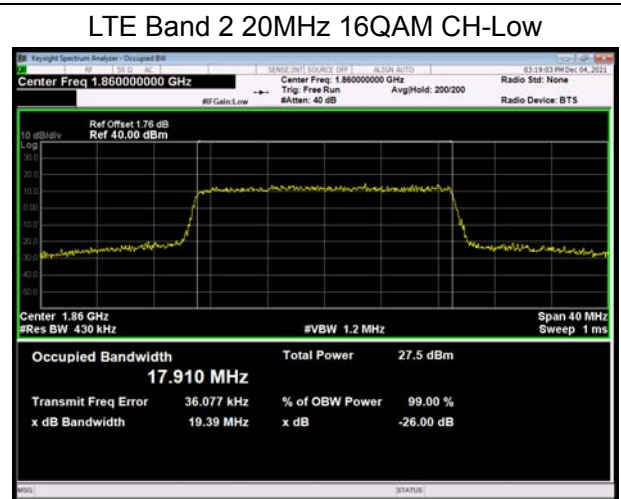
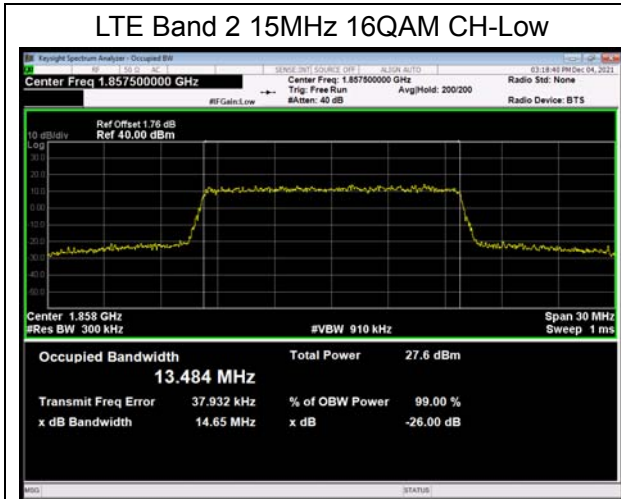

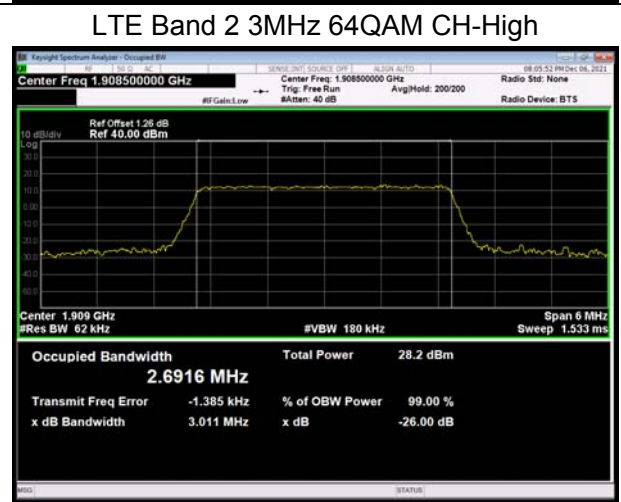
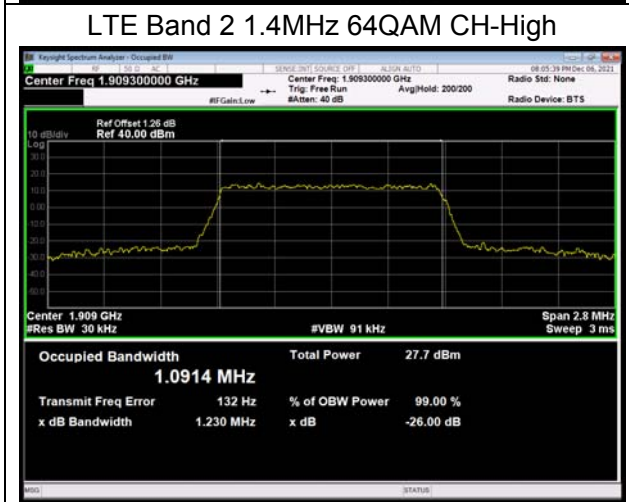
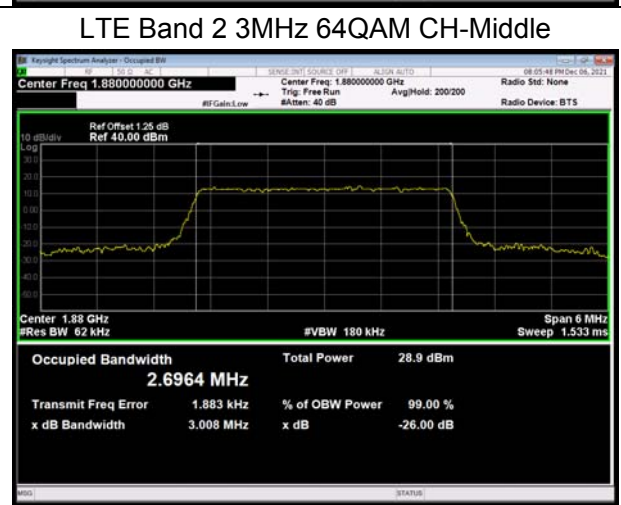
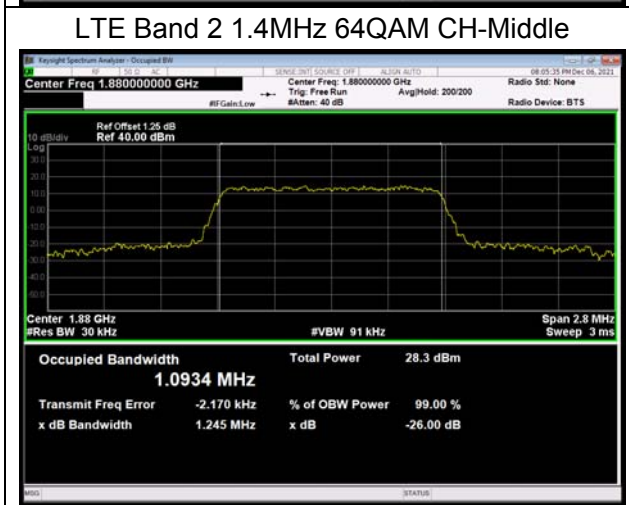
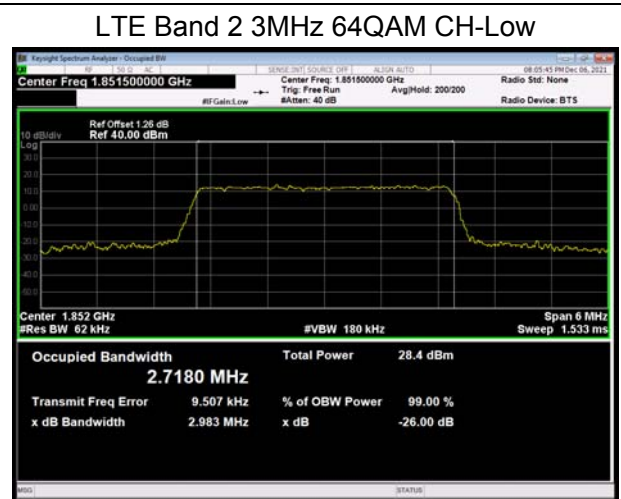
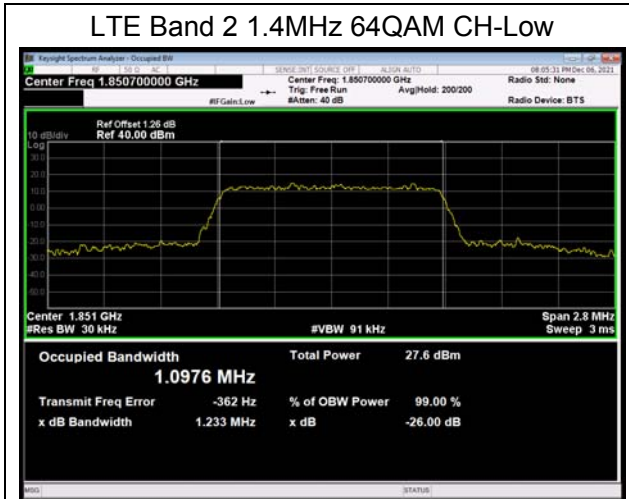

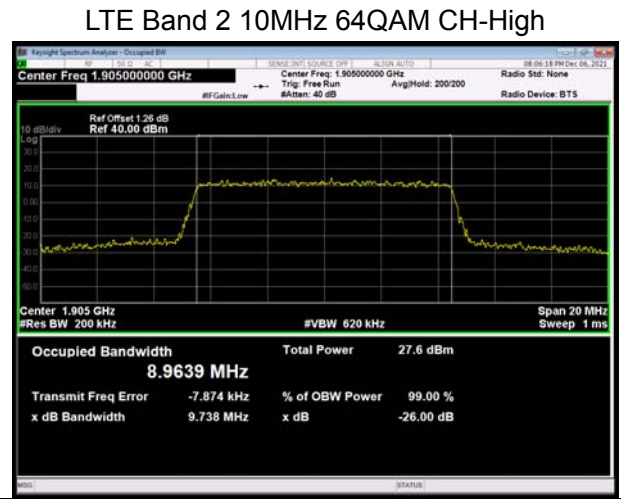
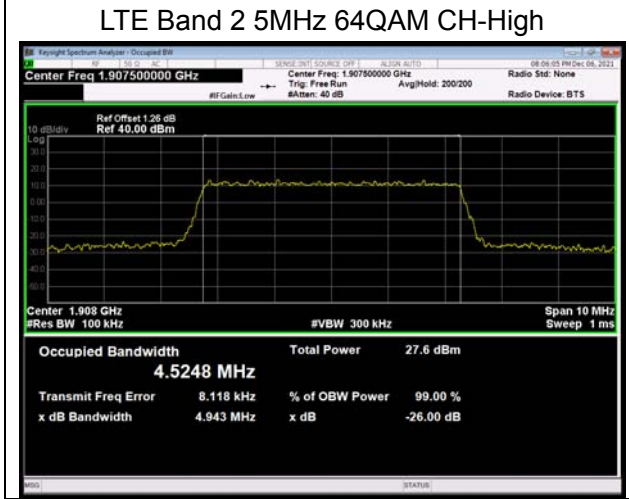
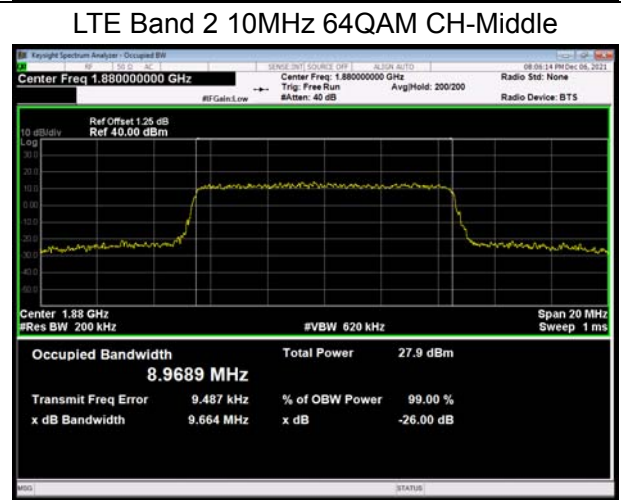
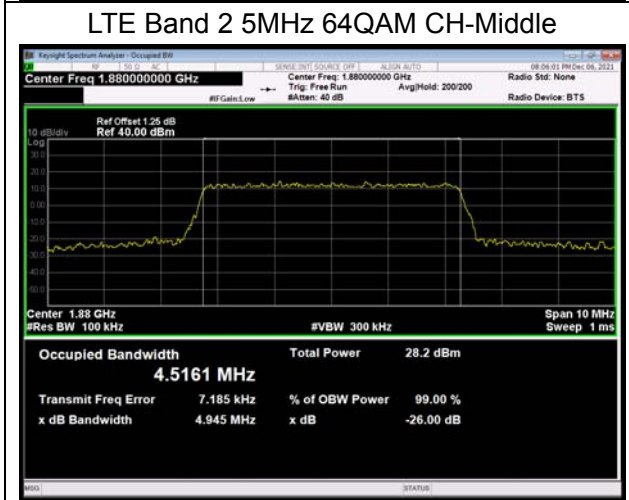
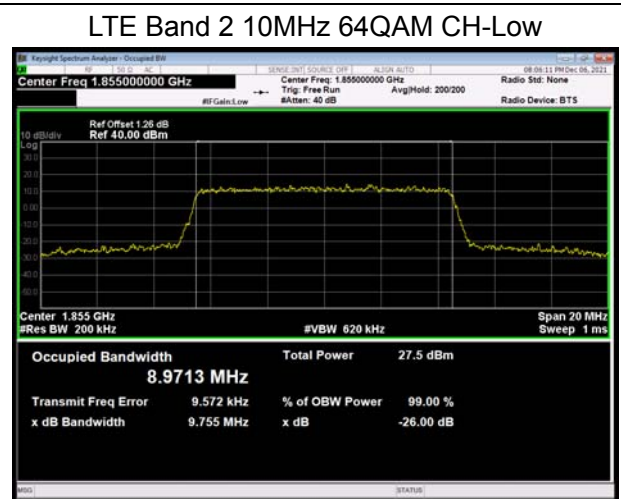
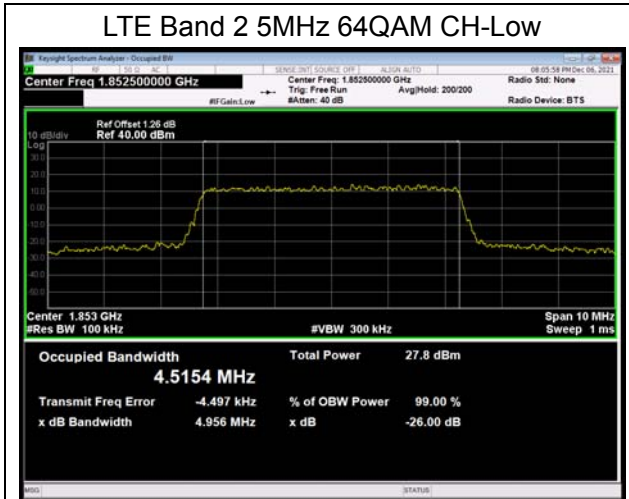

LTE Band 2 15MHz 64QAM CH-Low

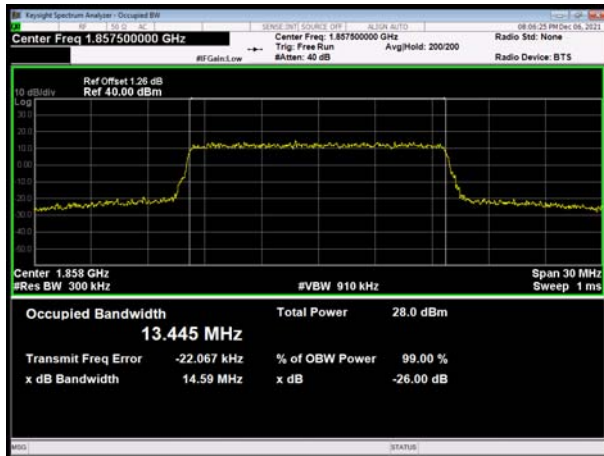

LTE Band 2 20MHz 64QAM CH-Low

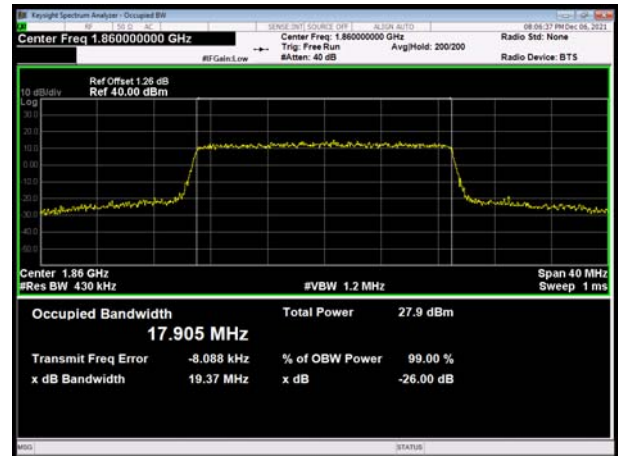

LTE Band 2 15MHz 64QAM CH-Middle

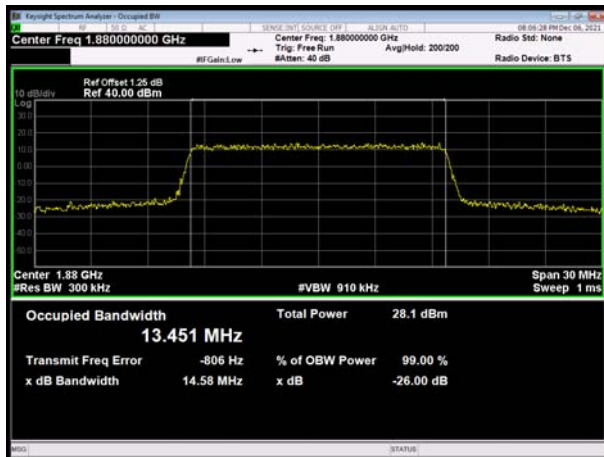

LTE Band 2 20MHz 64QAM CH-Middle



LTE Band 2 15MHz 64QAM CH-High

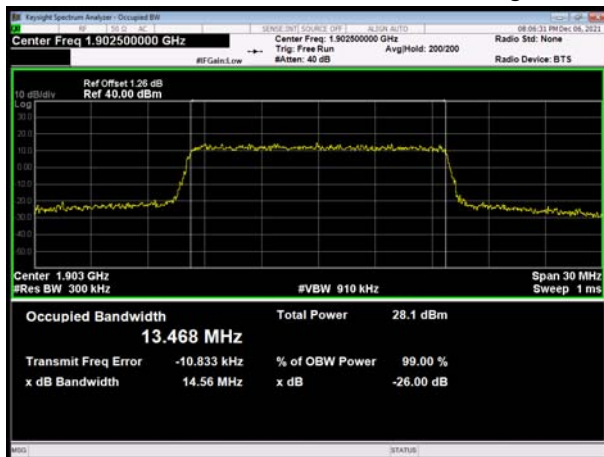

LTE Band 2 20MHz 64QAM CH-High

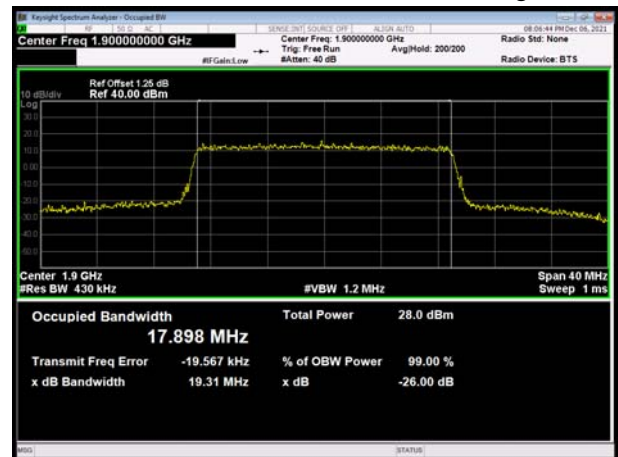

5.3. Band Edge Compliance

Ambient condition

Temperature	Relative humidity	Pressure
23°C ~25°C	45%~50%	101.5kPa

Method of Measurement

The EUT was connected to Spectrum Analyzer and Base Station Simulator via power Splitter. The band edge of the lowest and highest channels were measured. The Average detector is used and RBW is set to $\geq 1\%EBW$, VBW is set to 3x RBW.

Spectrum analyzer plots are included on the following pages.

Test Setup

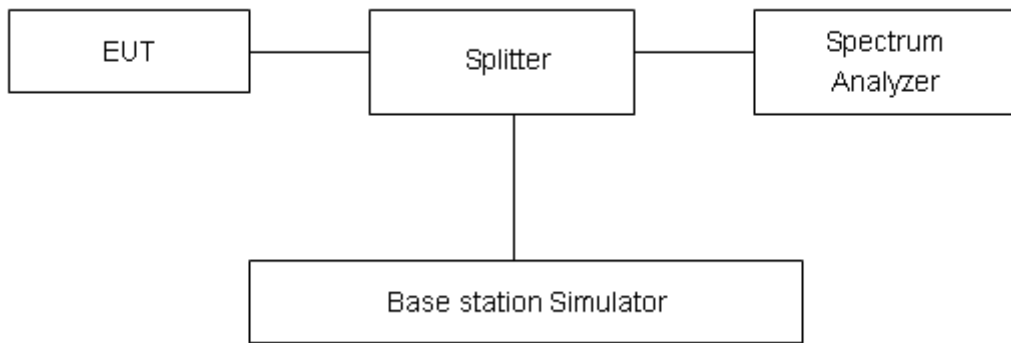

Limits

Rule Part 24.238(a) specifies that “on any frequency outside a licensee's frequency block, the power of any emission shall be attenuated below the transmitter power (P) by at least $43 + 10 \log_{10} (P)$ dB.”

Limit	-13 dBm
-------	---------

Measurement Uncertainty

The assessed measurement uncertainty to ensure 95% confidence level for the normal distribution is with the coverage factor $k = 1.96$, $U=0.684dB$.



Test Result:

WCDMA Band II RMC CH-Low



WCDMA Band II RMC CH-High



LTE Band 2 1.4MHz QPSK 1RB CH-Low

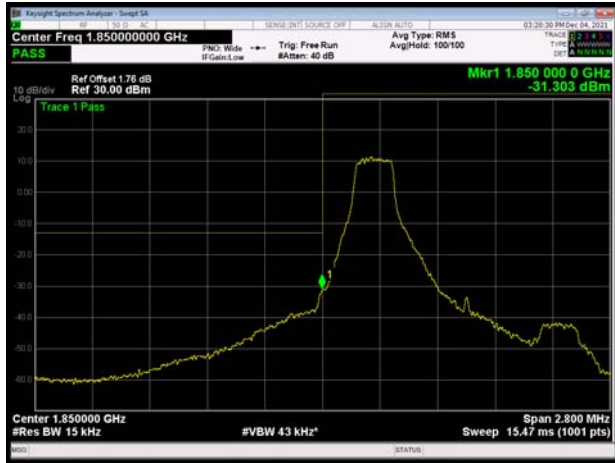

LTE Band 2 1.4MHz QPSK 1RB CH-High

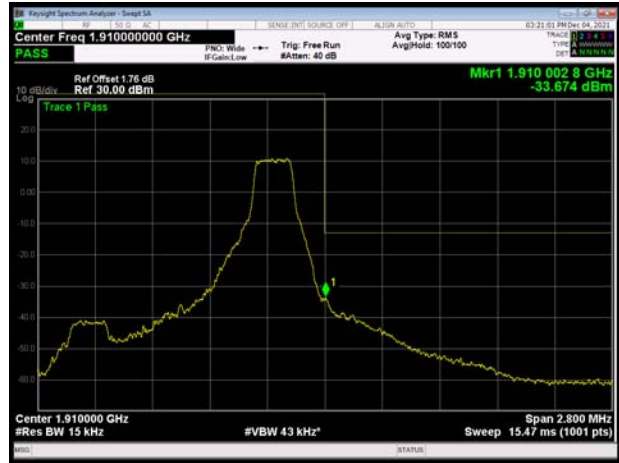

LTE Band 2 1.4MHz QPSK 100%RB CH-Low



LTE Band 2 1.4MHz QPSK 100%RB CH-High



LTE Band 2 3MHz QPSK 1RB CH-Low

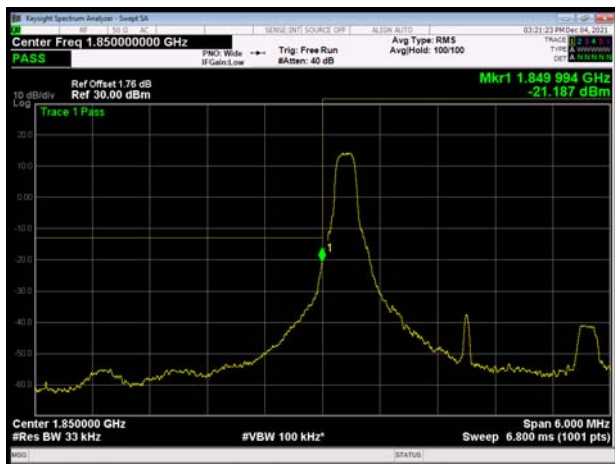

LTE Band 2 3MHz QPSK 1RB CH-High

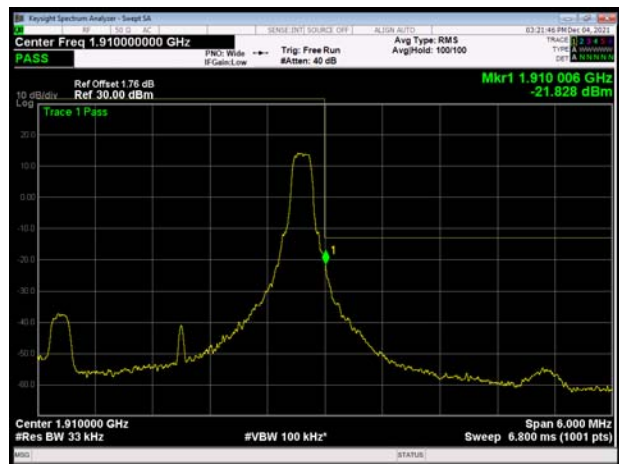



LTE Band 2 3MHz QPSK 100%RB CH-Low

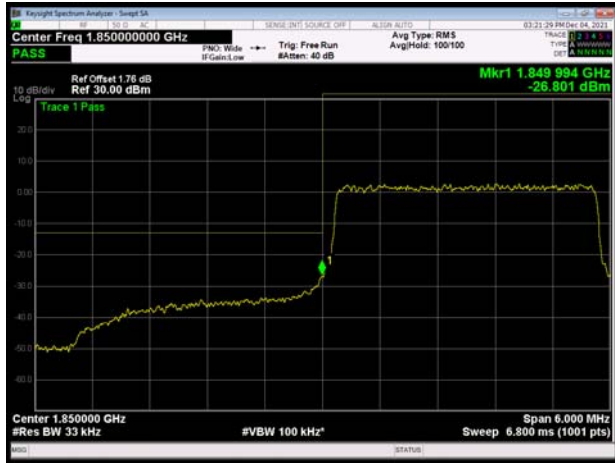

LTE Band 2 3MHz QPSK 100%RB CH-High

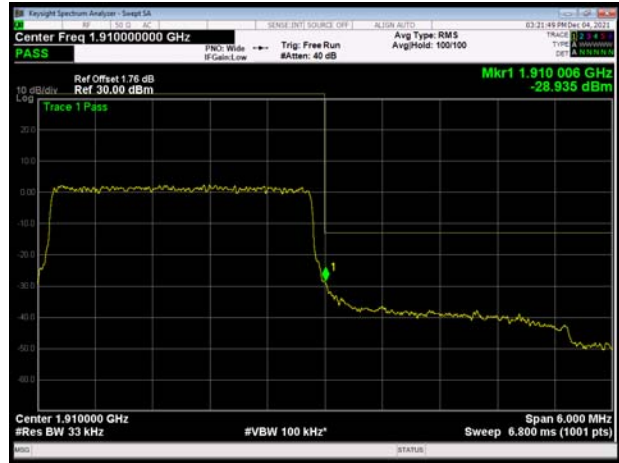

LTE Band 2 5MHz QPSK 1RB CH-Low

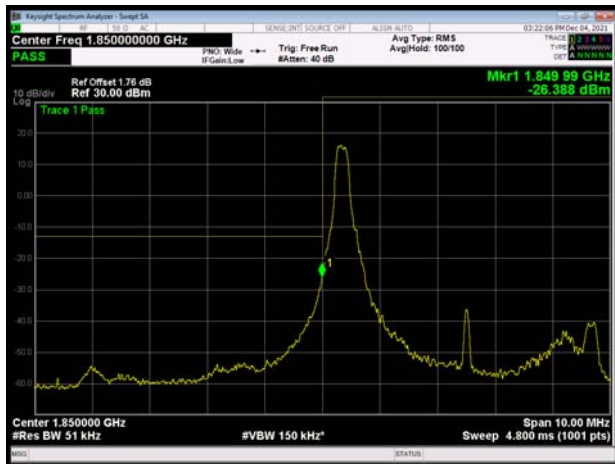

LTE Band 2 5MHz QPSK 1RB CH-High

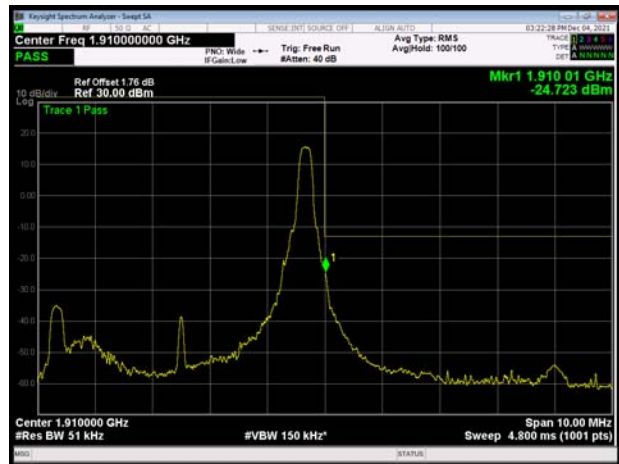

LTE Band 2 5MHz QPSK 100%RB CH-Low

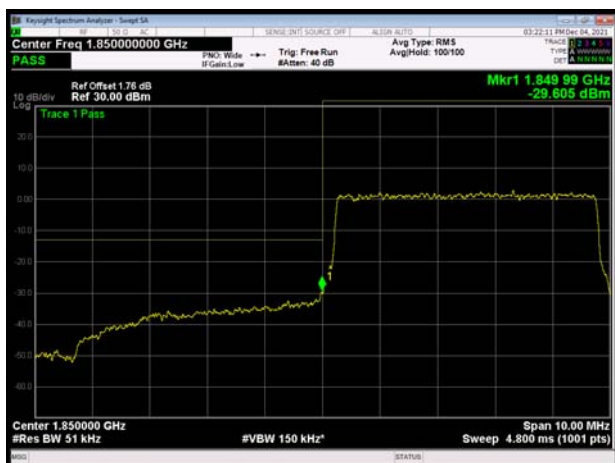

LTE Band 2 5MHz QPSK 100%RB CH-High

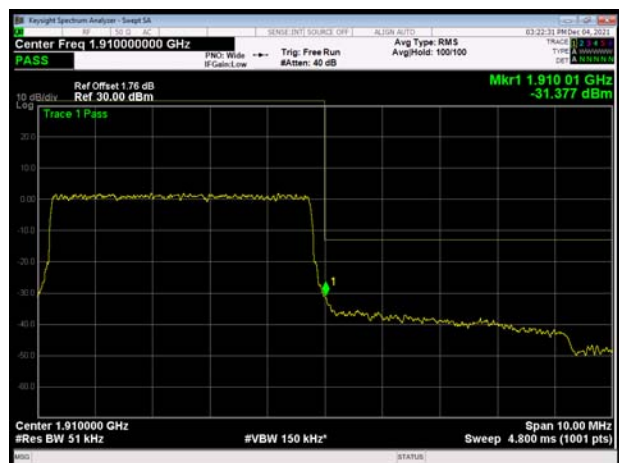



LTE Band 2 10MHz QPSK 1RB CH-Low

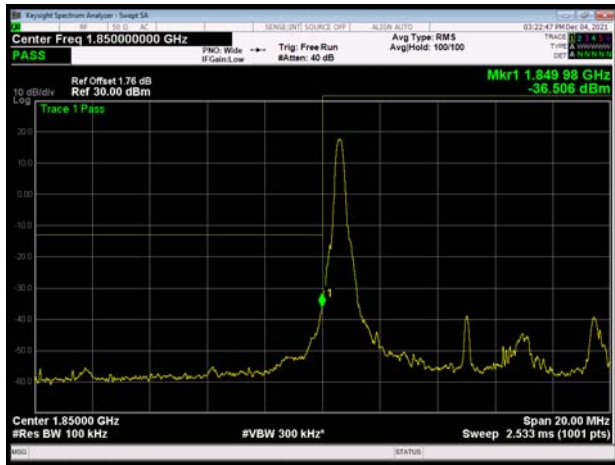

LTE Band 2 10MHz QPSK 1RB CH-High

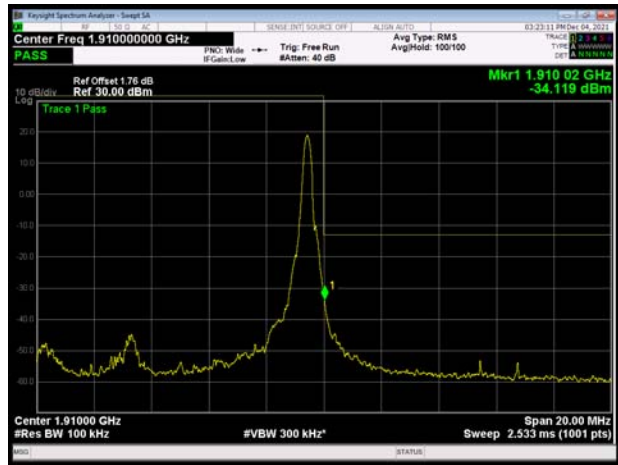

LTE Band 2 10MHz QPSK 100%RB CH-Low

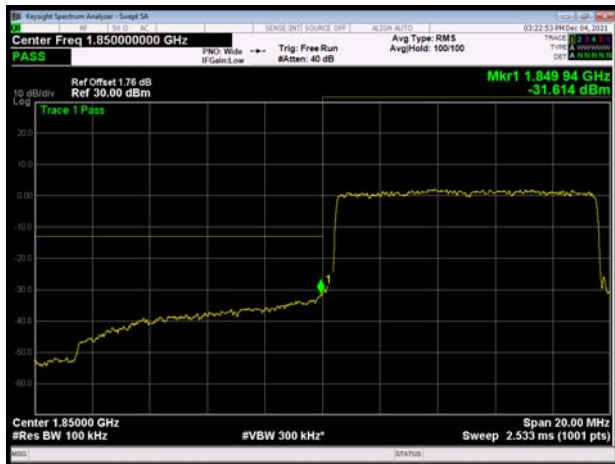

LTE Band 2 10MHz QPSK 100%RB CH-High

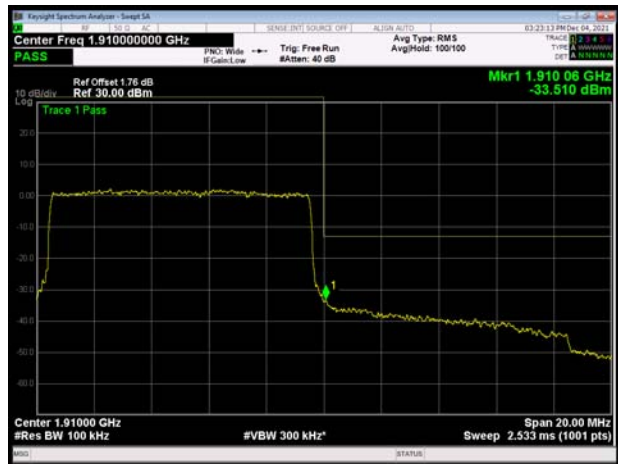

LTE Band 2 15MHz QPSK 1RB CH-Low

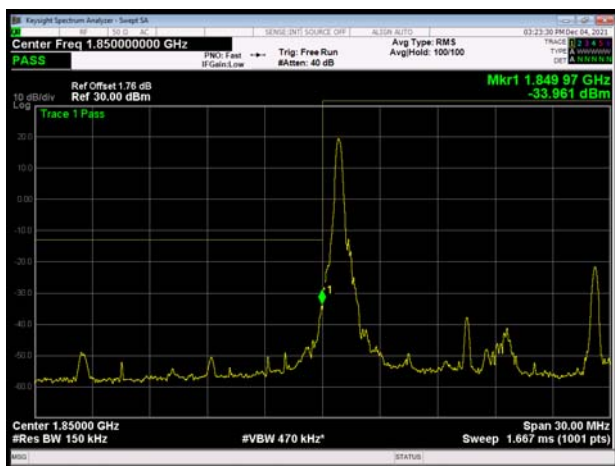

LTE Band 2 15MHz QPSK 1RB CH-High

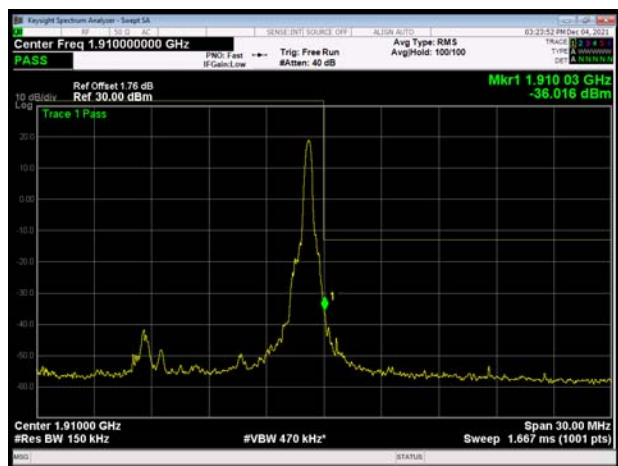



LTE Band 2 15MHz QPSK 100%RB CH-Low

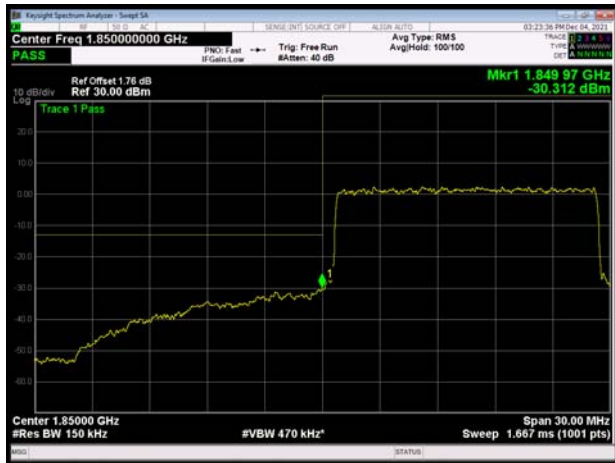

LTE Band 2 15MHz QPSK 100%RB CH-High



LTE Band 2 20MHz QPSK 1RB CH-Low

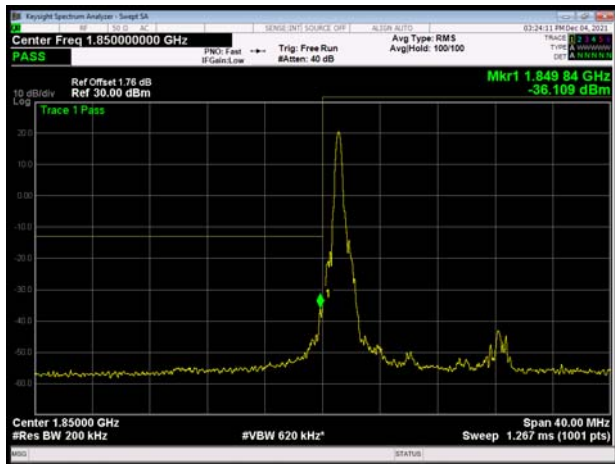

LTE Band 2 20MHz QPSK 1RB CH-High

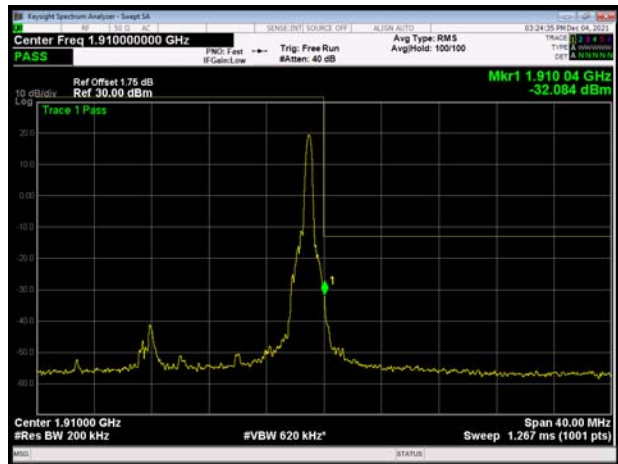

LTE Band 2 20MHz QPSK 100%RB CH-Low

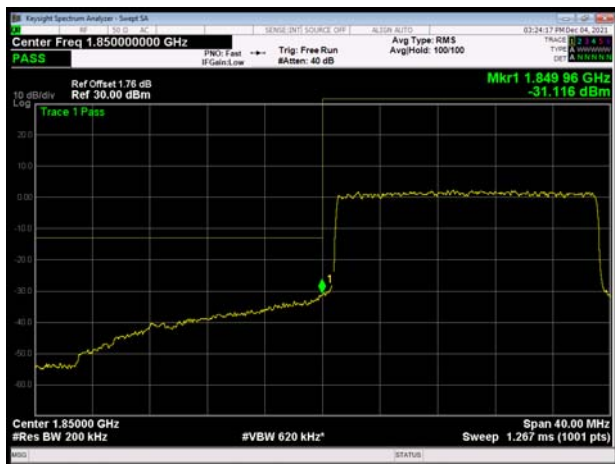

LTE Band 2 20MHz QPSK 100%RB CH-High



LTE Band 2 1.4MHz 16QAM 1RB CH-Low

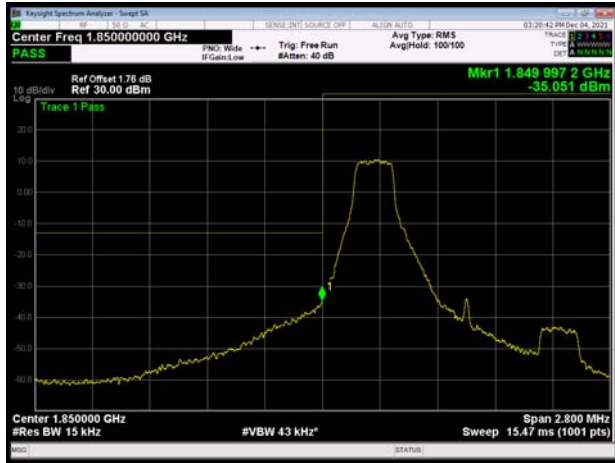

LTE Band 2 1.4MHz 16QAM 1RB CH-High

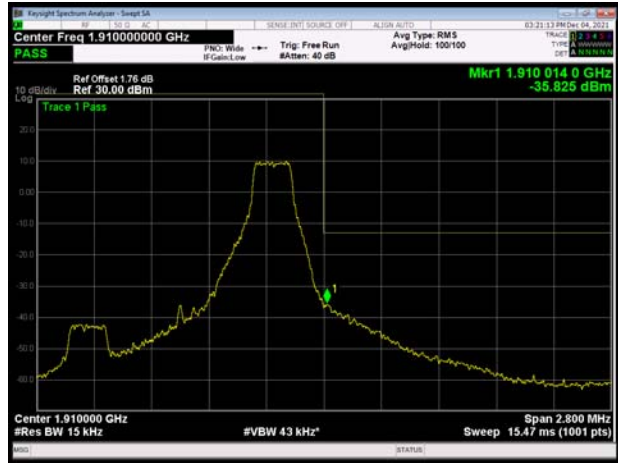

LTE Band 2 1.4MHz 16QAM 100%RB CH-Low



LTE Band 2 1.4MHz 16QAM 100%RB CH-High



LTE Band 2 3MHz 16QAM 1RB CH-Low

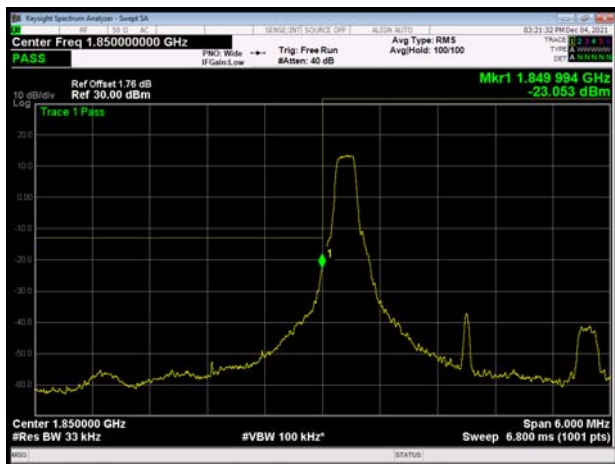

LTE Band 2 3MHz 16QAM 1RB CH-High

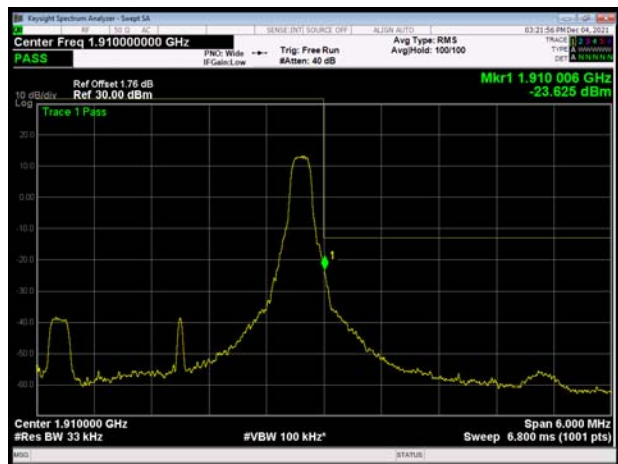



LTE Band 2 3MHz 16QAM 100%RB CH-Low

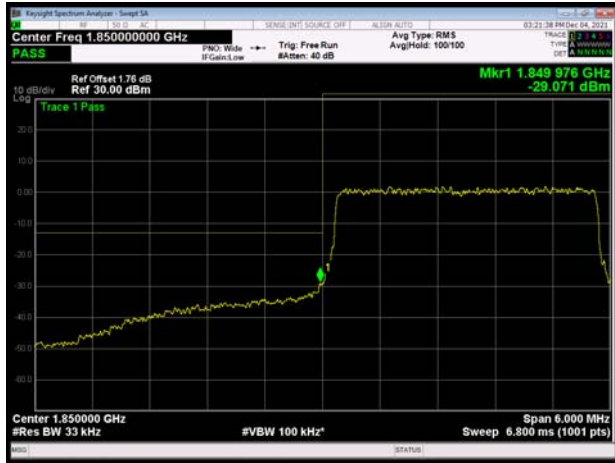

LTE Band 2 3MHz 16QAM 100%RB CH-High



LTE Band 2 5MHz 16QAM 1RB CH-Low

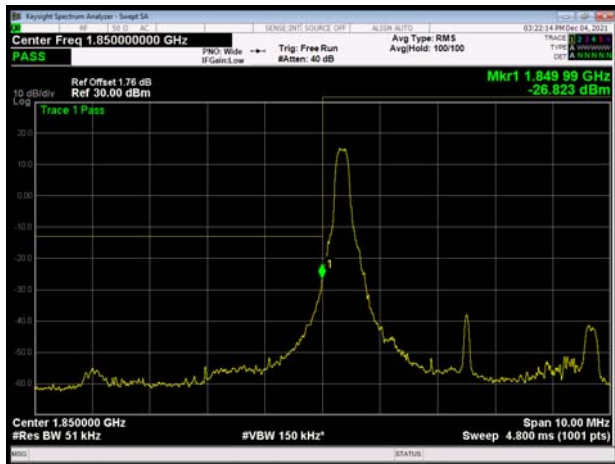

LTE Band 2 5MHz 16QAM 1RB CH-High

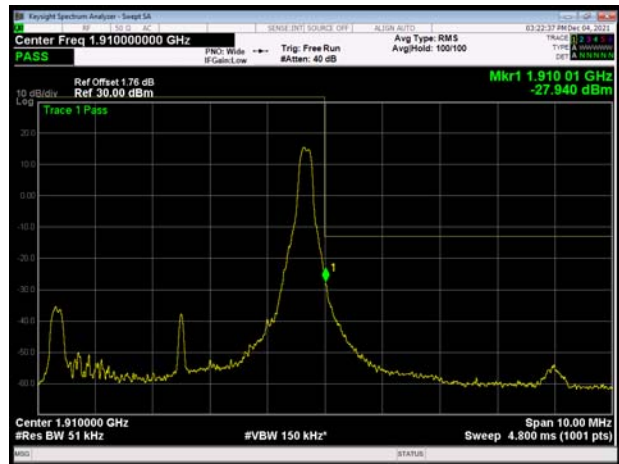

LTE Band 2 5MHz 16QAM 100%RB CH-Low

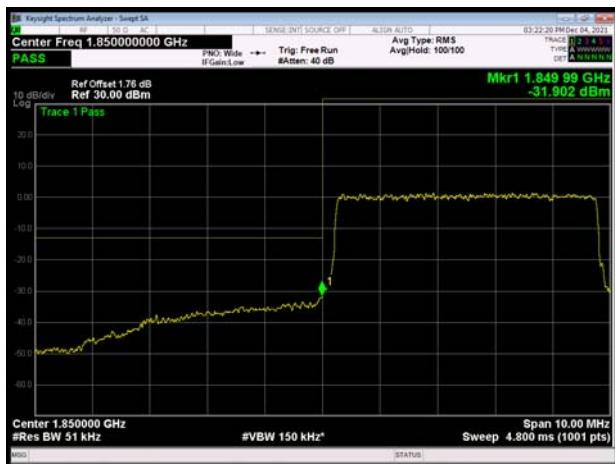

LTE Band 2 5MHz 16QAM 100%RB CH-High

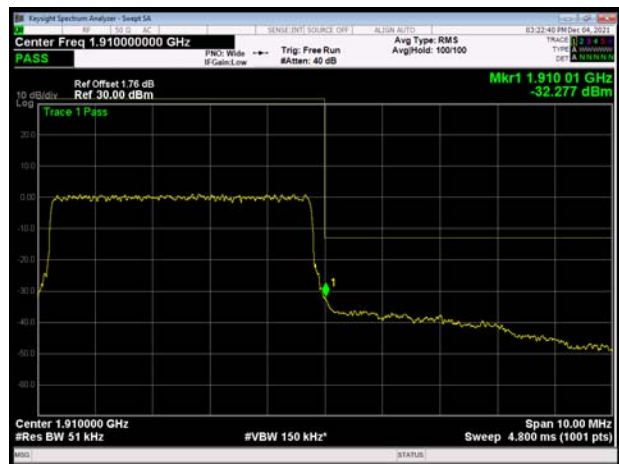



LTE Band 2 10MHz 16QAM 1RB CH-Low

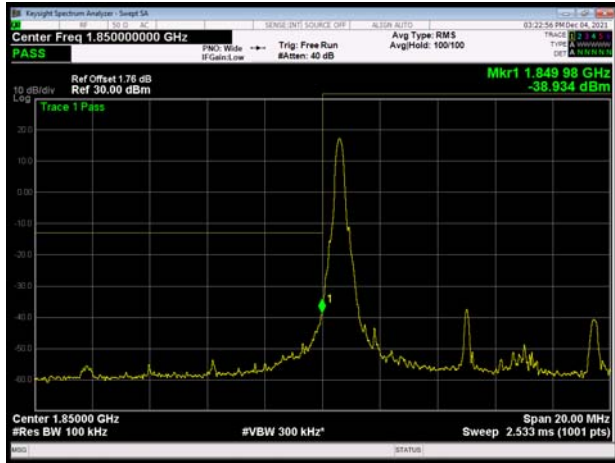

LTE Band 2 10MHz 16QAM 1RB CH-High

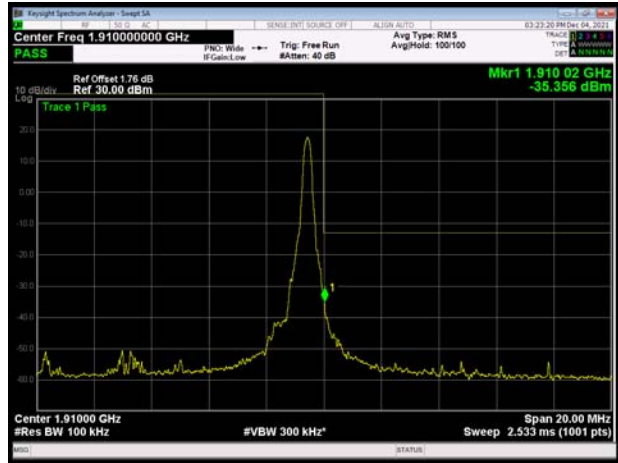

LTE Band 2 10MHz 16QAM 100%RB CH-Low

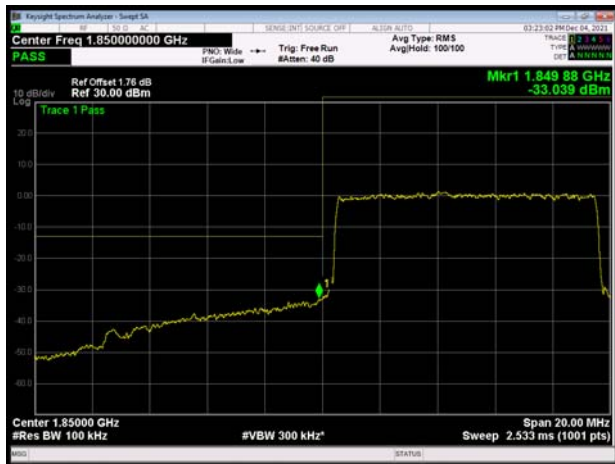

LTE Band 2 10MHz 16QAM 100%RB CH-High



LTE Band 2 15MHz 16QAM 1RB CH-Low

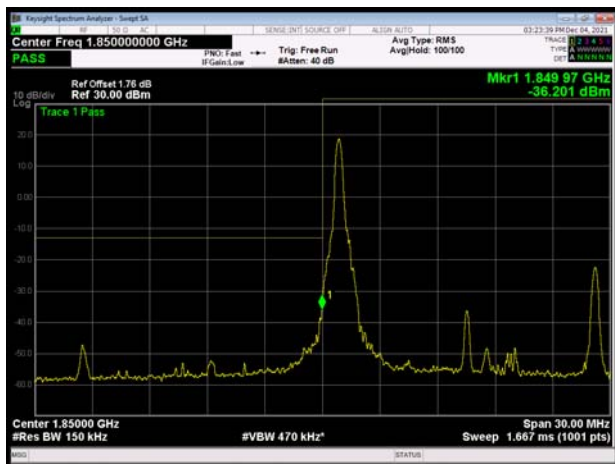

LTE Band 2 15MHz 16QAM 1RB CH-High

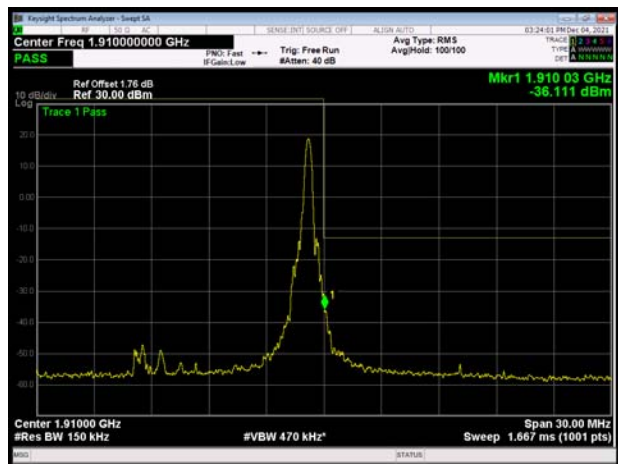



LTE Band 2 15MHz 16QAM 100%RB CH-Low

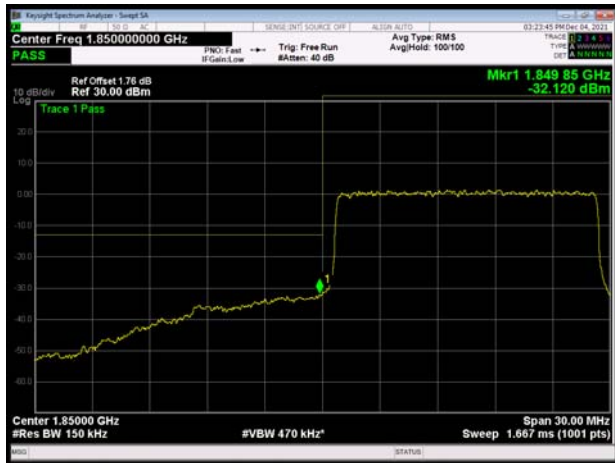

LTE Band 2 15MHz 16QAM 100%RB CH-High



LTE Band 2 20MHz 16QAM 1RB CH-Low

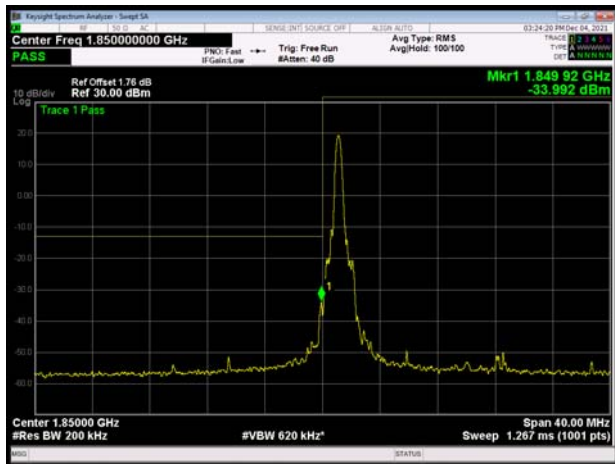

LTE Band 2 20MHz 16QAM 1RB CH-High

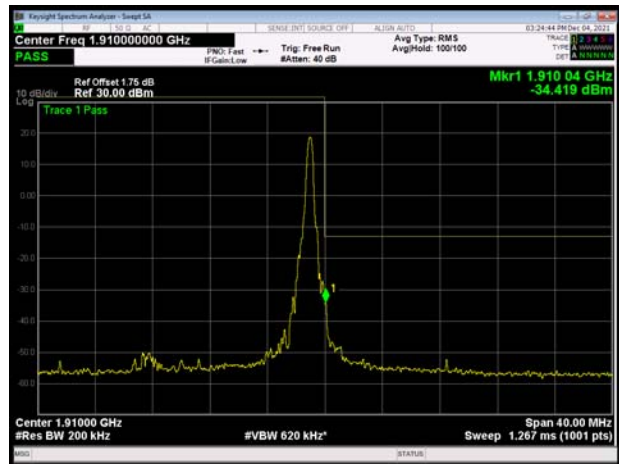

LTE Band 2 20MHz 16QAM 100%RB CH-Low

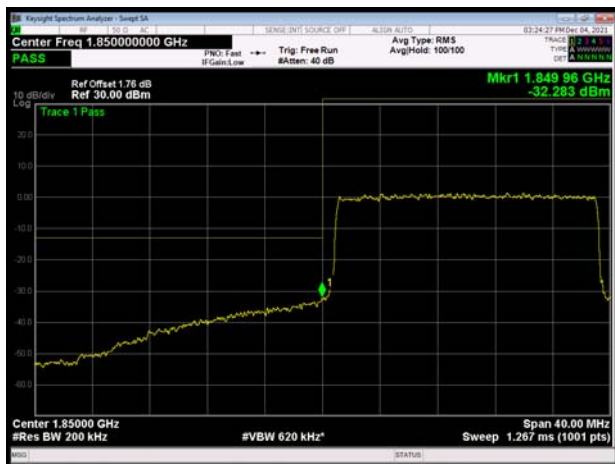

LTE Band 2 20MHz 16QAM 100%RB CH-High



LTE Band 2 1.4MHz 64QAM 1RB CH-Low

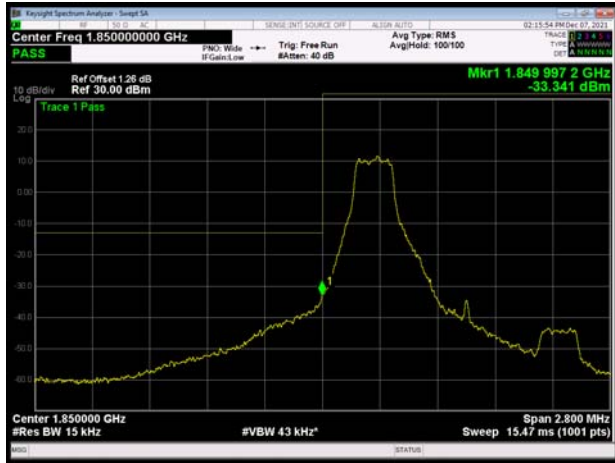

LTE Band 2 1.4MHz 64QAM 1RB CH-High

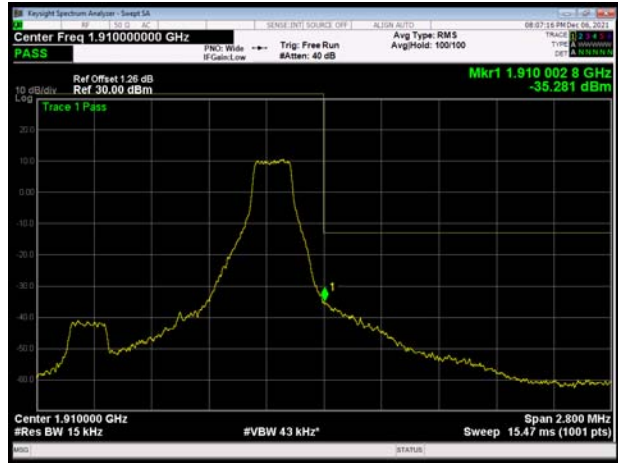

LTE Band 2 1.4MHz 64QAM 100%RB CH-Low



LTE Band 2 1.4MHz 64QAM 100%RB CH-High



LTE Band 2 3MHz 64QAM 1RB CH-Low

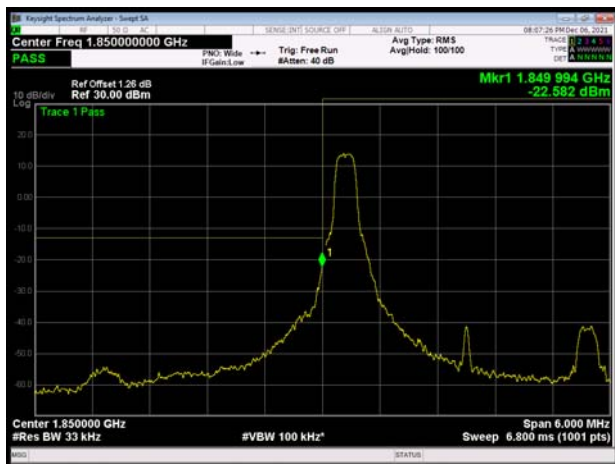

LTE Band 2 3MHz 64QAM 1RB CH-High

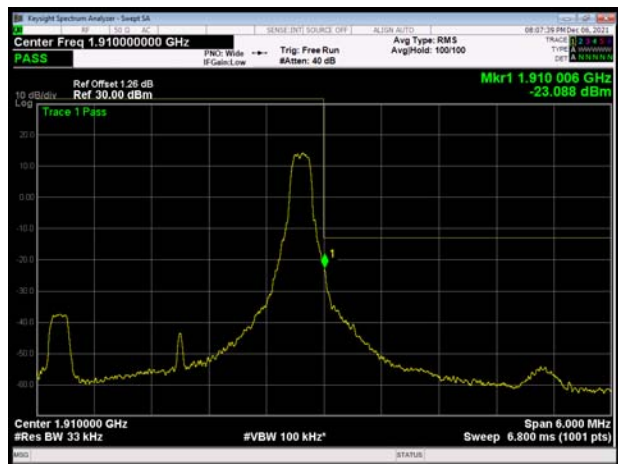



LTE Band 2 3MHz 64QAM 100%RB CH-Low

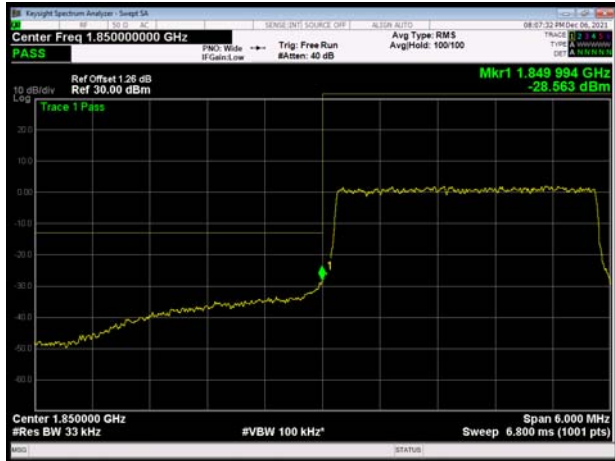

LTE Band 2 3MHz 64QAM 100%RB CH-High

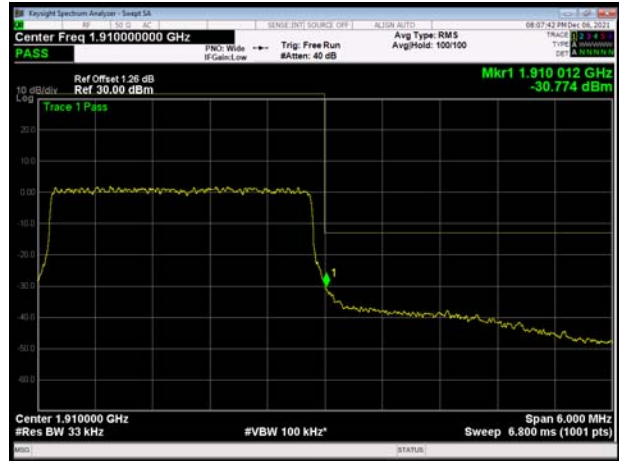

LTE Band 2 5MHz 64QAM 1RB CH-Low

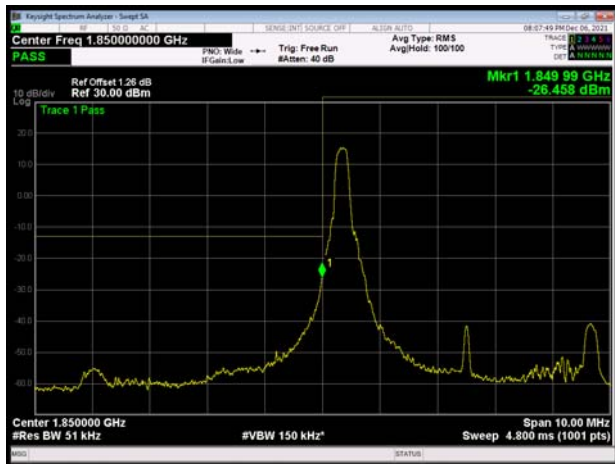

LTE Band 2 5MHz 64QAM 1RB CH-High

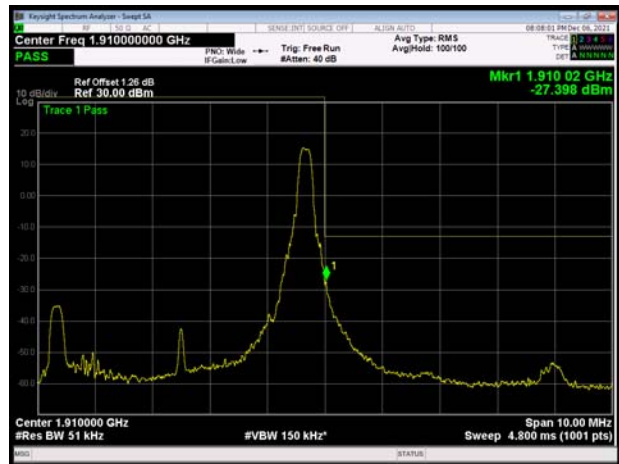

LTE Band 2 5MHz 64QAM 100%RB CH-Low

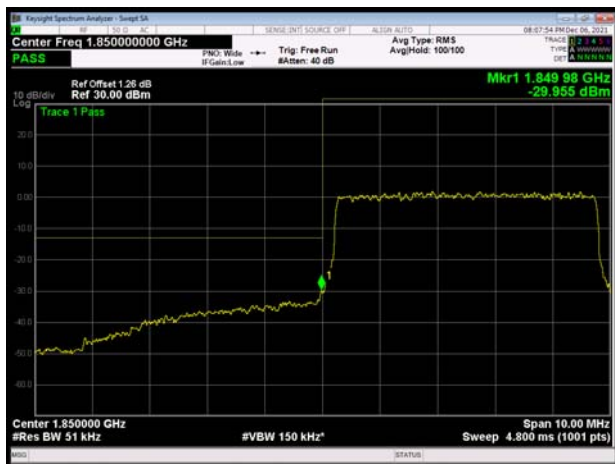

LTE Band 2 5MHz 64QAM 100%RB CH-High





LTE Band 2 10MHz 64QAM 1RB CH-Low

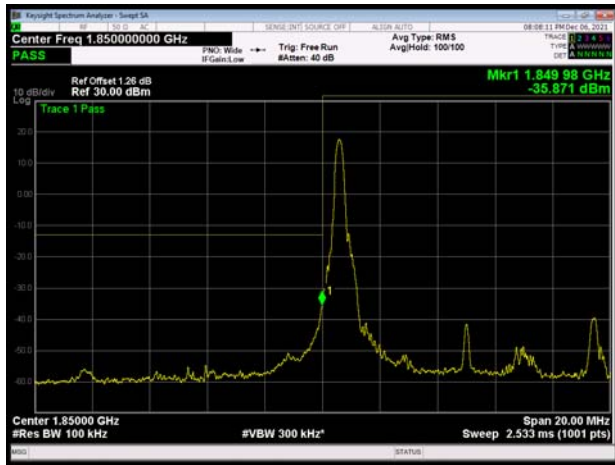

LTE Band 2 10MHz 64QAM 1RB CH-High

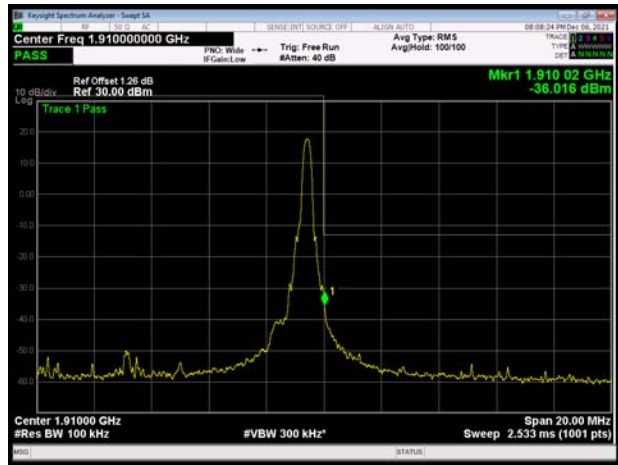

LTE Band 2 10MHz 64QAM 100%RB CH-Low

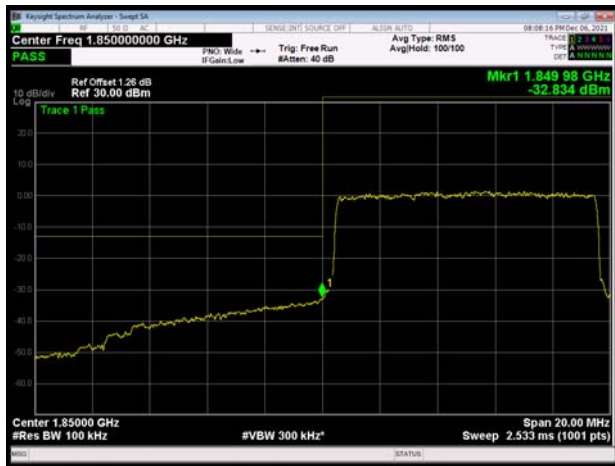

LTE Band 2 10MHz 64QAM 100%RB CH-High



LTE Band 2 15MHz 64QAM 1RB CH-Low

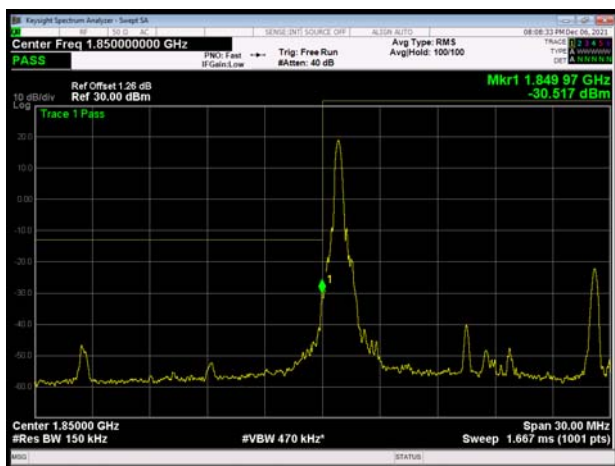

LTE Band 2 15MHz 64QAM 1RB CH-High

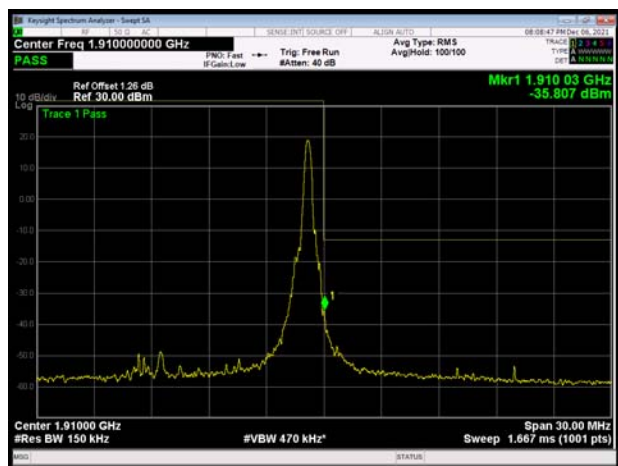



LTE Band 2 15MHz 64QAM 100%RB CH-Low

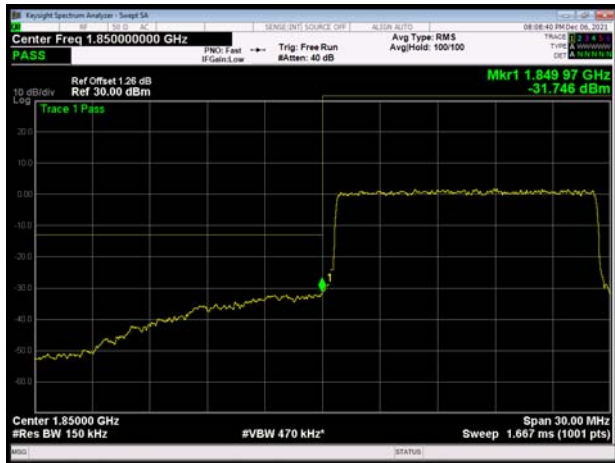

LTE Band 2 15MHz 64QAM 100%RB CH-High



LTE Band 2 20MHz 64QAM 1RB CH-Low

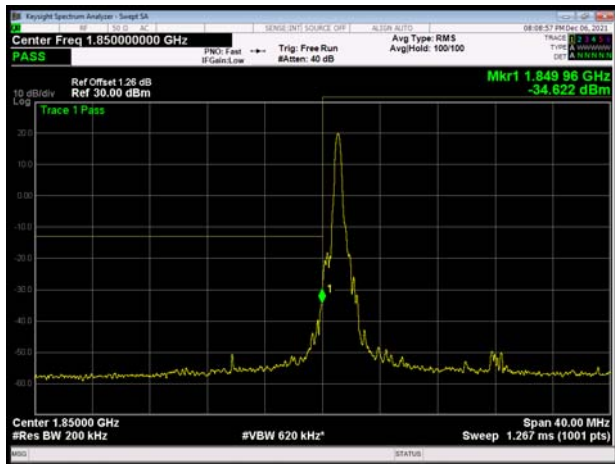

LTE Band 2 20MHz 64QAM 1RB CH-High

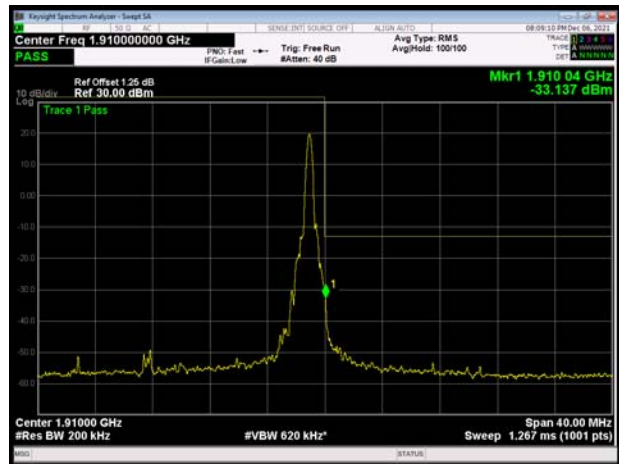

LTE Band 2 20MHz 64QAM 100%RB CH-Low

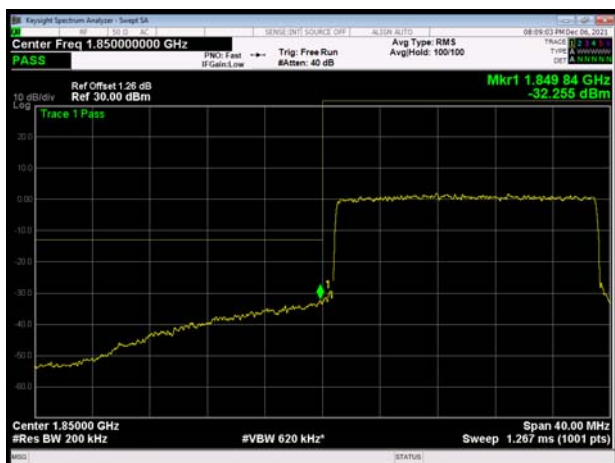

LTE Band 2 20MHz 64QAM 100%RB CH-High

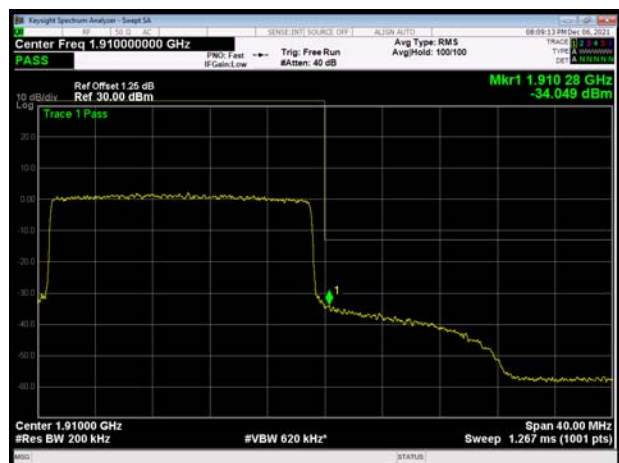

5.4. Peak-to-Average Power Ratio (PAPR)

Ambient condition

Temperature	Relative humidity	Pressure
23°C ~25°C	45%~50%	101.5kPa

Methods of Measurement

Measure the total peak power and record as PPk. And measure the total average power and record as PAvg. Both the peak and average power levels must be expressed in the same logarithmic units (e.g., dBm). Determine the PAPR from:

$$PAPR (dB) = PPk (dBm) - PAvg (dBm).$$

Test Setup

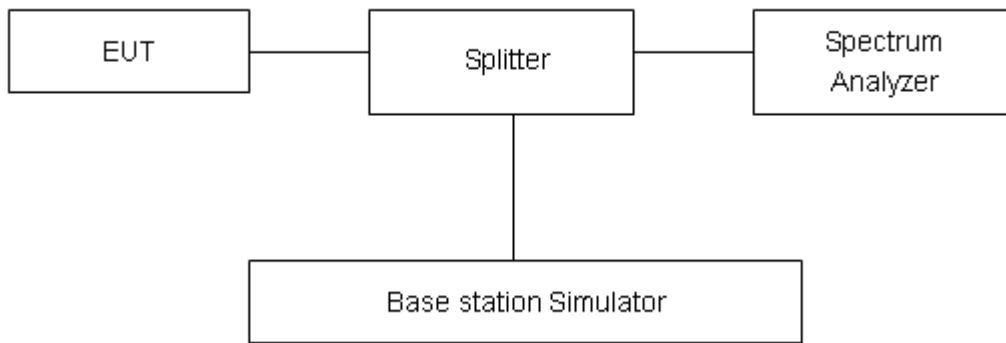

Limits

In measuring transmissions in this band using an average power technique, the peak-to-average ratio (PAR) of the transmission may not exceed 13 dB in 24.232(d).

Measurement Uncertainty

The assessed measurement uncertainty to ensure 95% confidence level for the normal distribution is with the coverage factor $k = 2$, $U = 0.4$ dB.

**Test Results**

Mode	Channel	Frequency (MHz)	Peak(dBm)	Avg(dBm)	PAPR(dB)	Limit(dB)	Conclusion
WCDMA Band II (RMC)	9262	1852.4	26.21	23.96	2.25	≤13	PASS
	9400	1880	26.39	24.00	2.39	≤13	PASS
	9538	1907.6	24.05	21.46	2.59	≤13	PASS

LTE Band 2								
Modulation	Bandwidth (MHz)	Channel	Frequency (MHz)	Peak (dBm)	Avg (dBm)	PAPR (dB)	Limit (dB)	Conclusion
QPSK	1.4	18607	1850.7	24.73	20.27	4.46	≤13	PASS
		18900	1880.0	25.17	20.82	4.35	≤13	PASS
		19193	1909.3	24.77	19.98	4.79	≤13	PASS
	3	18615	1851.5	24.71	20.31	4.40	≤13	PASS
		18900	1880	25.11	20.83	4.28	≤13	PASS
		19185	1908.5	24.71	20.03	4.68	≤13	PASS
	5	18625	1852.5	24.75	20.31	4.44	≤13	PASS
		18900	1880	25.15	20.79	4.36	≤13	PASS
		19175	1907.5	24.82	20.10	4.72	≤13	PASS
	10	18650	1855	24.68	20.20	4.48	≤13	PASS
		18900	1880	24.98	20.58	4.40	≤13	PASS
		19150	1905	24.81	20.21	4.60	≤13	PASS
	15	18675	1857.5	25.32	20.61	4.71	≤13	PASS
		18900	1880	25.45	20.72	4.73	≤13	PASS
		19125	1902.5	25.31	20.51	4.80	≤13	PASS
	20	18700	1860	25.11	20.43	4.68	≤13	PASS
		18900	1880	25.22	20.52	4.70	≤13	PASS
		19100	1900	25.18	20.45	4.73	≤13	PASS
16QAM	1.4	18607	1850.7	24.56	19.33	5.23	≤13	PASS
		18900	1880.0	25.09	19.88	5.21	≤13	PASS
		19193	1909.3	24.58	19.00	5.58	≤13	PASS
	3	18615	1851.5	24.59	19.37	5.22	≤13	PASS
		18900	1880	25.03	19.90	5.13	≤13	PASS
		19185	1908.5	24.61	19.08	5.53	≤13	PASS
	5	18625	1852.5	24.58	19.36	5.22	≤13	PASS
		18900	1880	25.02	19.87	5.15	≤13	PASS
		19175	1907.5	24.64	19.17	5.47	≤13	PASS
	10	18650	1855	24.52	19.25	5.27	≤13	PASS
		18900	1880	24.88	19.64	5.24	≤13	PASS
		19150	1905	24.65	19.25	5.40	≤13	PASS
	15	18675	1857.5	25.07	19.68	5.39	≤13	PASS
		18900	1880	25.20	19.79	5.41	≤13	PASS
		19125	1902.5	25.06	19.56	5.50	≤13	PASS
	20	18700	1860	24.95	19.49	5.46	≤13	PASS
		18900	1880	25.05	19.58	5.47	≤13	PASS
		19100	1900	25.02	19.51	5.51	≤13	PASS
64QAM	1.4	18607	1850.7	24.96	19.87	5.09	≤13	PASS
		18900	1880.0	25.54	20.51	5.03	≤13	PASS
		19193	1909.3	25.12	19.76	5.36	≤13	PASS



	3	18615	1851.5	24.98	19.92	5.06	≤13	PASS
		18900	1880	25.46	20.47	4.99	≤13	PASS
		19185	1908.5	25.19	19.87	5.32	≤13	PASS
	5	18625	1852.5	24.94	19.90	5.04	≤13	PASS
		18900	1880	25.41	20.40	5.01	≤13	PASS
		19175	1907.5	25.15	19.87	5.28	≤13	PASS
	10	18650	1855	24.90	19.76	5.14	≤13	PASS
		18900	1880	25.25	20.16	5.09	≤13	PASS
		19150	1905	25.12	19.87	5.25	≤13	PASS
	15	18675	1857.5	25.41	20.17	5.24	≤13	PASS
		18900	1880	25.59	20.32	5.27	≤13	PASS
		19125	1902.5	25.47	20.17	5.30	≤13	PASS
	20	18700	1860	25.33	19.96	5.37	≤13	PASS
		18900	1880	25.47	20.09	5.38	≤13	PASS
		19100	1900	25.44	20.10	5.34	≤13	PASS

5.5.Frequency Stability

Ambient condition

Temperature	Relative humidity	Pressure
23°C ~25°C	45%~50%	101.5kPa

Method of Measurement

Frequency Stability (Temperature Variation)

The temperature inside the climate chamber is varied from -30°C to +50°C in 10°C step size,

(1) With all power removed, the temperature was decreased to 0°C and permitted to stabilize for three hours.

(2) Measure the carrier frequency with the test equipment in a “call mode”. These measurements should be made within 1 minute of powering up the mobile station, to prevent significant self warming.

(3) Repeat the above measurements at 10°C increments from -30°C to +50°C. Allow at least 1.5 hours at each temperature, un-powered, before making measurements.

Frequency Stability (Voltage Variation)

The frequency stability shall be measured with variation of primary supply voltage as follows:

Primary Supply Voltage: The primary supply voltage is varied from 85% to 115% of the nominal value for non hand-carried battery and AC powered equipment. For hand-carried, battery-powered equipment, primary supply voltage is reduced to the battery operating end point which shall be specified by the manufacturer.

This transceiver is specified to operate with an input voltage of between 10.8V and 13.2V, with a nominal voltage of 12V.

Test setup

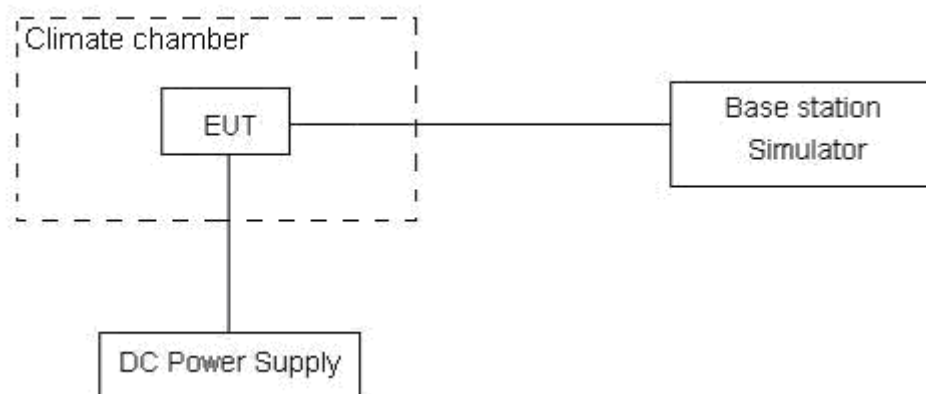

**Limits**

The frequency stability shall be sufficient to ensure that the fundamental emission stays within the authorized frequency block

Measurement Uncertainty

The assessed measurement uncertainty to ensure 99.75% confidence level for the normal distribution is with the coverage factor $k = 3$, $U = 0.01\text{ppm}$.

Test Result

WCDMA Band II						
Condition		Freq.Error (Hz)	Freq.Error (Hz)	Frequency Stability (ppm)	Frequency Stability (ppm)	Verdict
Temperature	Voltage	BPSK	QPSK	BPSK	QPSK	
Normal (25°C)	Normal	7.81	6.98	0.00416	0.00371	PASS
Extreme (50°C)		5.13	17.06	0.00273	0.00907	PASS
Extreme (40°C)		2.51	13.40	0.00134	0.00713	PASS
Extreme (30°C)		5.86	14.90	0.00311	0.00792	PASS
Extreme (20°C)		17.62	1.09	0.00937	0.00058	PASS
Extreme (10°C)		3.04	16.48	0.00162	0.00877	PASS
Extreme (0°C)		13.70	6.25	0.00729	0.00333	PASS
Extreme (-10°C)		2.48	1.43	0.00132	0.00076	PASS
Extreme (-20°C)		14.46	2.37	0.00769	0.00126	PASS
Extreme (-30°C)		4.10	17.54	0.00218	0.00933	PASS
25°C	LV	6.51	12.71	0.00346	0.00676	PASS
	HV	16.02	5.58	0.00852	0.00297	PASS

LTE Band 2								
Condition		Freq.Error (Hz)	Freq.Error (Hz)	Freq.Error (Hz)	Frequency Stability (ppm)	Frequency Stability (ppm)	Frequency Stability (ppm)	Verdict
BANDWIDTH	1.4MHz							
Temperature	Voltage	64QAM	16QAM	QPSK	64QAM	16QAM	QPSK	
Normal (25°C)	Normal	14.74	5.03	14.51	0.00784	0.00268	0.00772	PASS
Extreme (50°C)		12.70	16.40	5.60	0.00675	0.00872	0.00298	PASS
Extreme (40°C)		15.85	11.50	10.59	0.00843	0.00611	0.00563	PASS
Extreme (30°C)		11.56	15.20	9.44	0.00615	0.00808	0.00502	PASS
Extreme (20°C)		8.05	3.70	11.08	0.00428	0.00197	0.00589	PASS
Extreme (10°C)		9.39	12.54	3.41	0.00499	0.00667	0.00181	PASS
Extreme (0°C)		1.68	15.58	9.24	0.00089	0.00829	0.00492	PASS
Extreme (-10°C)		15.17	2.63	3.54	0.00807	0.00140	0.00188	PASS
Extreme (-20°C)		5.00	2.35	17.06	0.00266	0.00125	0.00908	PASS
Extreme (-30°C)		1.21	3.15	5.96	0.00065	0.00168	0.00317	PASS
25°C	LV	17.06	15.56	5.57	0.00907	0.00828	0.00297	PASS
	HV	6.56	8.26	17.37	0.00349	0.00440	0.00924	PASS
Condition		Freq.Error (Hz)	Freq.Error (Hz)	Freq.Error (Hz)	Frequency Stability (ppm)	Frequency Stability (ppm)	Frequency Stability (ppm)	Verdict
BANDWIDTH	3MHz							



Temperature	Voltage	64QAM	16QAM	QPSK	64QAM	16QAM	QPSK	
Normal (25°C)	Normal	13.25	9.75	15.65	0.00705	0.00519	0.00833	PASS
Extreme (50°C)		16.80	6.57	11.20	0.00894	0.00349	0.00596	PASS
Extreme (40°C)		9.49	7.39	3.24	0.00505	0.00393	0.00172	PASS
Extreme (30°C)		3.90	13.98	13.84	0.00208	0.00744	0.00736	PASS
Extreme (20°C)		5.03	10.54	10.79	0.00268	0.00561	0.00574	PASS
Extreme (10°C)		10.05	10.16	3.98	0.00535	0.00540	0.00212	PASS
Extreme (0°C)		9.82	5.26	13.48	0.00522	0.00280	0.00717	PASS
Extreme (-10°C)		6.95	4.29	17.81	0.00370	0.00228	0.00947	PASS
Extreme (-20°C)		9.90	1.18	11.62	0.00527	0.00063	0.00618	PASS
Extreme (-30°C)		16.31	14.10	1.38	0.00867	0.00750	0.00073	PASS
25°C	LV	6.80	16.67	15.05	0.00362	0.00887	0.00800	PASS
	HV	17.57	7.31	2.25	0.00935	0.00389	0.00119	PASS
Condition		Freq.Error (Hz)	Freq.Error (Hz)	Freq.Error (Hz)	Frequency Stability (ppm)	Frequency Stability (ppm)	Frequency Stability (ppm)	Verdict
BANDWIDTH	5MHz							
Temperature	Voltage	64QAM	16QAM	QPSK	64QAM	16QAM	QPSK	
Normal (25°C)	Normal	6.28	12.18	9.53	0.00334	0.00648	0.00507	PASS
Extreme (50°C)		7.21	15.63	3.75	0.00383	0.00831	0.00200	PASS
Extreme (40°C)		16.48	14.71	6.85	0.00877	0.00782	0.00364	PASS
Extreme (30°C)		9.01	1.08	10.73	0.00479	0.00058	0.00571	PASS
Extreme (20°C)		16.34	15.32	6.97	0.00869	0.00815	0.00370	PASS
Extreme (10°C)		17.04	14.36	10.47	0.00907	0.00764	0.00557	PASS
Extreme (0°C)		1.01	7.81	11.60	0.00054	0.00415	0.00617	PASS
Extreme (-10°C)		8.90	13.38	16.46	0.00474	0.00712	0.00876	PASS
Extreme (-20°C)		5.07	10.33	3.17	0.00269	0.00549	0.00169	PASS
Extreme (-30°C)		6.47	10.02	6.15	0.00344	0.00533	0.00327	PASS
25°C	LV	1.98	11.87	12.01	0.00105	0.00631	0.00639	PASS
	HV	7.07	8.88	7.89	0.00376	0.00472	0.00420	PASS
Condition		Freq.Error (Hz)	Freq.Error (Hz)	Freq.Error (Hz)	Frequency Stability (ppm)	Frequency Stability (ppm)	Frequency Stability (ppm)	Verdict
BANDWIDTH	10MHz							
Temperature	Voltage	64QAM	16QAM	QPSK	64QAM	16QAM	QPSK	
Normal (25°C)	Normal	2.50	4.50	10.08	0.00133	0.00240	0.00536	PASS
Extreme (50°C)		6.97	1.45	1.84	0.00371	0.00077	0.00098	PASS
Extreme (40°C)		14.21	2.95	3.03	0.00756	0.00157	0.00161	PASS
Extreme (30°C)		14.23	10.50	9.97	0.00757	0.00559	0.00530	PASS
Extreme (20°C)		1.88	15.56	8.25	0.00100	0.00828	0.00439	PASS
Extreme (10°C)		14.16	3.68	2.33	0.00753	0.00196	0.00124	PASS
Extreme (0°C)		1.29	17.43	4.77	0.00069	0.00927	0.00254	PASS
Extreme (-10°C)		12.56	14.97	6.58	0.00668	0.00796	0.00350	PASS



Extreme (-20°C)		16.41	10.88	3.55	0.00873	0.00579	0.00189	PASS	
Extreme (-30°C)		9.84	6.13	6.92	0.00523	0.00326	0.00368	PASS	
25°C	LV	4.85	16.57	5.06	0.00258	0.00881	0.00269	PASS	
	HV	1.35	17.78	7.95	0.00072	0.00946	0.00423	PASS	
Condition		Freq.Error (Hz)	Freq.Error (Hz)	Freq.Error (Hz)	Frequency Stability (ppm)	Frequency Stability (ppm)	Frequency Stability (ppm)	Verdict	
BANDWIDTH	15MHz								
Temperature	Voltage	64QAM	16QAM	QPSK	64QAM	16QAM	QPSK		
Normal (25°C)	Normal	6.38	10.56	12.20	0.00339	0.00562	0.00649	PASS	
Extreme (50°C)		11.58	8.41	7.68	0.00616	0.00447	0.00408	PASS	
Extreme (40°C)		7.22	7.46	14.96	0.00384	0.00397	0.00796	PASS	
Extreme (30°C)		1.68	4.83	10.86	0.00089	0.00257	0.00577	PASS	
Extreme (20°C)		8.64	6.33	14.64	0.00460	0.00337	0.00779	PASS	
Extreme (10°C)		8.11	2.90	5.48	0.00431	0.00154	0.00292	PASS	
Extreme (0°C)		8.98	11.47	15.91	0.00478	0.00610	0.00846	PASS	
Extreme (-10°C)		15.47	9.20	17.47	0.00823	0.00489	0.00929	PASS	
Extreme (-20°C)		5.85	11.05	12.64	0.00311	0.00588	0.00672	PASS	
Extreme (-30°C)		8.32	4.35	13.01	0.00442	0.00232	0.00692	PASS	
25°C		LV	5.73	3.31	7.04	0.00305	0.00176	0.00375	PASS
		HV	12.47	15.14	9.11	0.00664	0.00805	0.00485	PASS
Condition		Freq.Error (Hz)	Freq.Error (Hz)	Freq.Error (Hz)	Frequency Stability (ppm)	Frequency Stability (ppm)	Frequency Stability (ppm)	Verdict	
BANDWIDTH	20MHz								
Temperature	Voltage	64QAM	16QAM	QPSK	64QAM	16QAM	QPSK		
Normal (25°C)	Normal	15.51	3.49	12.13	0.00825	0.00185	0.00645	PASS	
Extreme (50°C)		2.00	13.08	8.94	0.00106	0.00696	0.00475	PASS	
Extreme (40°C)		17.89	5.94	9.73	0.00952	0.00316	0.00517	PASS	
Extreme (30°C)		16.54	4.52	15.76	0.00880	0.00241	0.00838	PASS	
Extreme (20°C)		9.98	16.47	7.34	0.00531	0.00876	0.00391	PASS	
Extreme (10°C)		9.48	7.30	16.30	0.00504	0.00389	0.00867	PASS	
Extreme (0°C)		10.79	7.25	17.20	0.00574	0.00386	0.00915	PASS	
Extreme (-10°C)		3.06	11.11	16.18	0.00163	0.00591	0.00861	PASS	
Extreme (-20°C)		11.67	4.23	14.20	0.00621	0.00225	0.00756	PASS	
Extreme (-30°C)		15.17	14.02	7.02	0.00807	0.00746	0.00373	PASS	
25°C		LV	12.82	11.56	6.98	0.00682	0.00615	0.00371	PASS
		HV	8.60	10.07	14.47	0.00458	0.00536	0.00769	PASS

5.6. Spurious Emissions at Antenna Terminals

Ambient condition

Temperature	Relative humidity	Pressure
23°C ~25°C	45%~50%	101.5kPa

Method of Measurement

The EUT was connected to Spectrum Analyzer and Base Station Simulator via power Splitter. The measurement is carried out using a spectrum analyzer. The spectrum analyzer scans from 9kHz to the 10th harmonic of the carrier. The peak detector is used.

RBW is set to 100kHz, VBW is set to 300kHz for 30MHz~1GHz

RBW is set to 1MHz, VBW is set to 3MHz for above 1GHz, Sweep is set to ATUO.

RBW is set to 1 kHz (0.009MHz~ 0.15 MHz),

RBW is set to 10 kHz (0.15 MHz~ 30 MHz)

RBW is set to 100 kHz (30MHz~1000 MHz)

RBW is set to 1000 kHz (above 1000MHz)

The modulation mode and RB allocation refer to section 5.1, using the maximum output power configuration.

Test setup

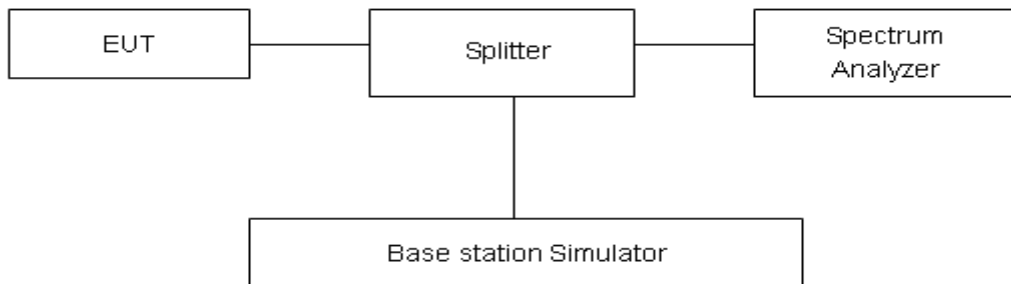

Limits

Rule Part 24.238(a) specifies that “on any frequency outside a licensee’s frequency block, the power of any emission shall be attenuated below the transmitter power (P) by at least 43 + 10 log₁₀ (P) dB.”

Limit	-13 dBm
-------	---------

Measurement Uncertainty

The assessed measurement uncertainty to ensure 99.75% confidence level for the normal distribution is with the coverage factor $k = 1.96$.

Frequency	Uncertainty
9kHz-1GHz	0.684 dB
1GHz-20GHz	1.407 dB

Test Result

Sweep the whole frequency band through the range from 9kHz to the 10th harmonic of the carrier, the emissions more than 20 dB below the limit are not reported.

The signal beyond the limit is carrier.

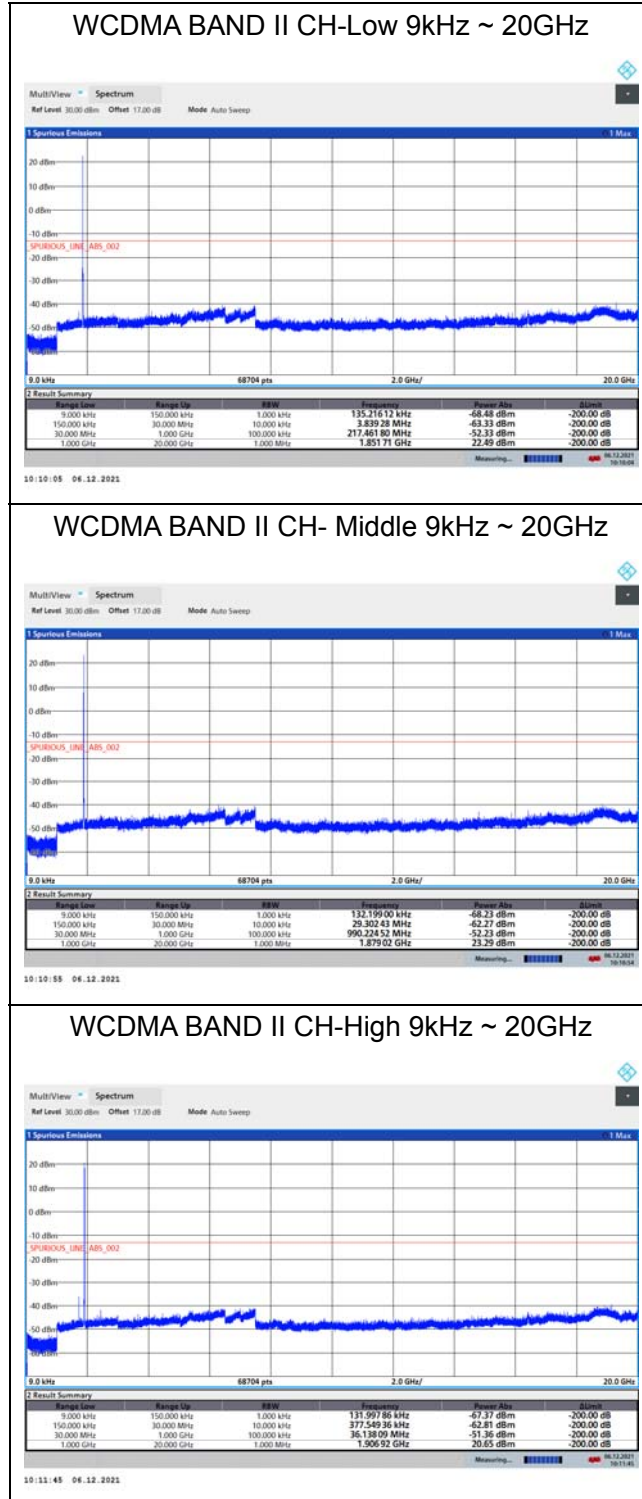

LTE Band 2 1.4MHz CH-Low 9kHz~20GHz

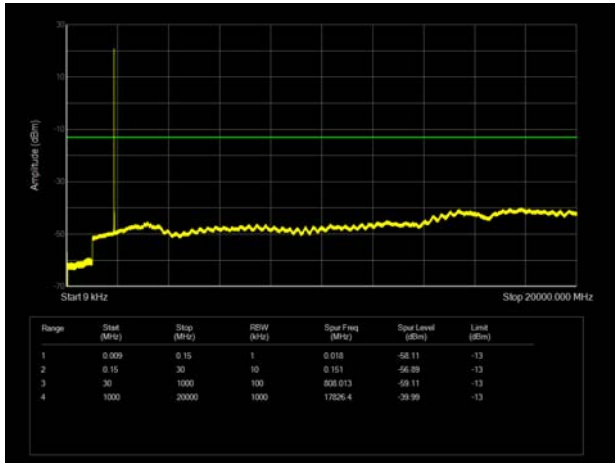

LTE Band 2 3MHz CH-Low 9kHz~20GHz

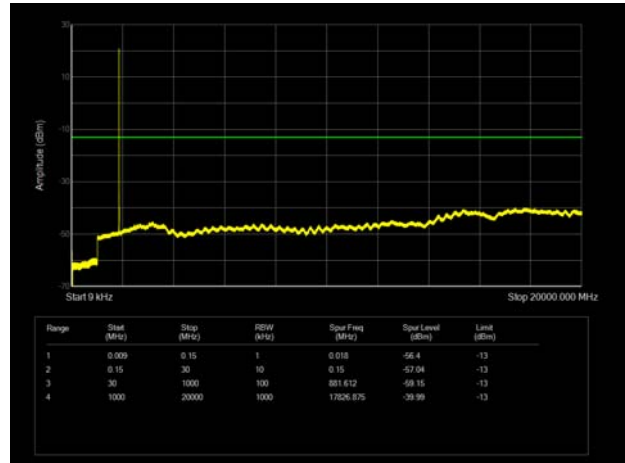

LTE Band 2 1.4MHz CH-Middle 9kHz~20GHz

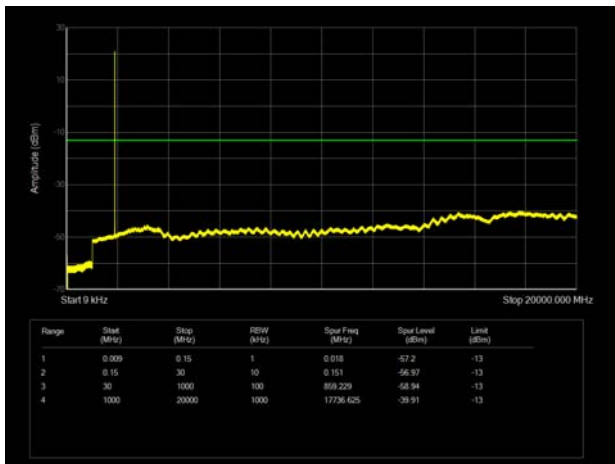

LTE Band 2 3MHz CH-Middle 9kHz~20GHz

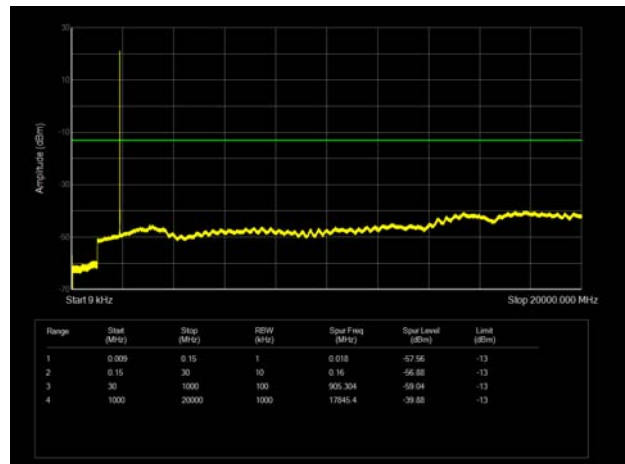

LTE Band 2 1.4MHz CH-High 9kHz~20GHz

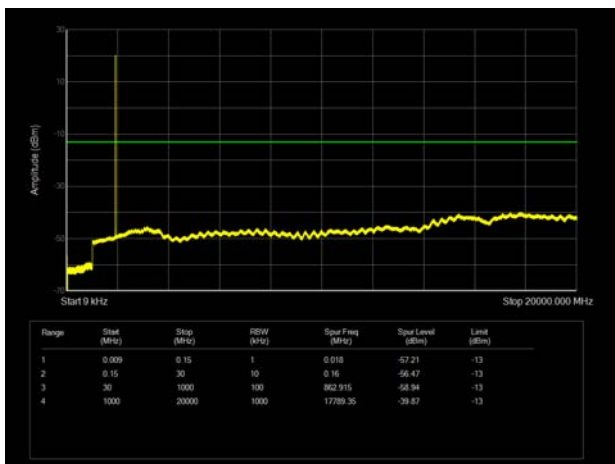

LTE Band 2 3MHz CH-High 9kHz~20GHz

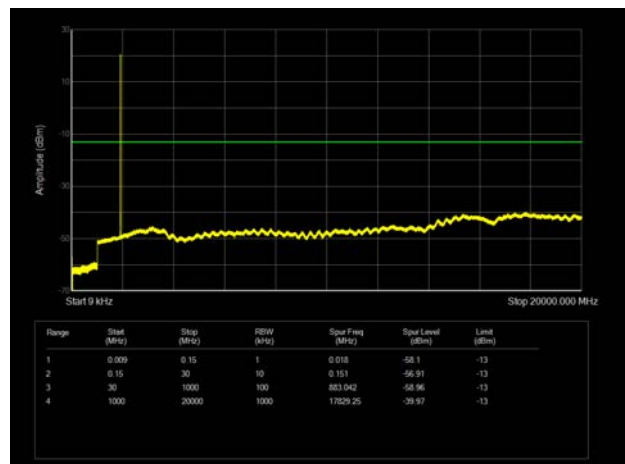

LTE Band 2 5MHz CH-Low 9kHz~20GHz

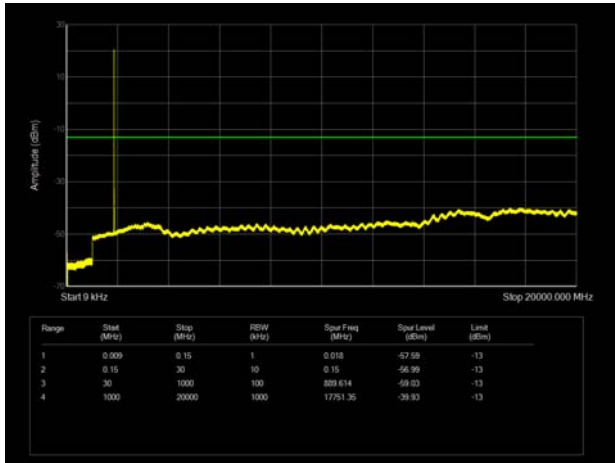

LTE Band 2 10MHz CH-Low 9kHz~20GHz

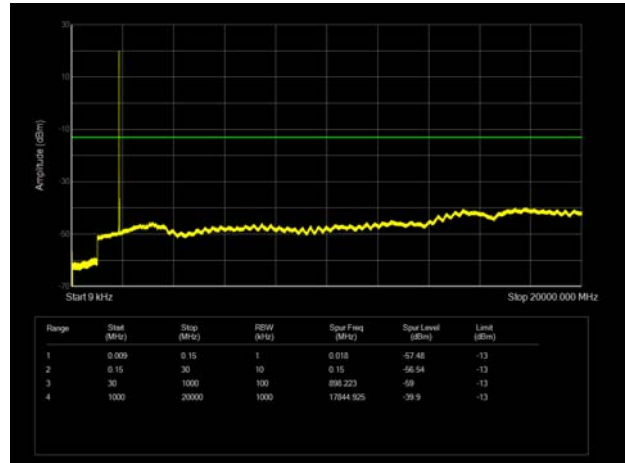

LTE Band 2 5MHz CH-Middle 9kHz~20GHz

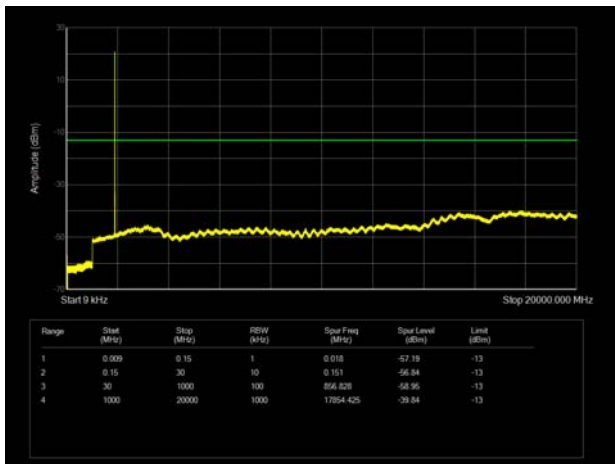

LTE Band 2 10MHz CH-Middle 9kHz~20GHz

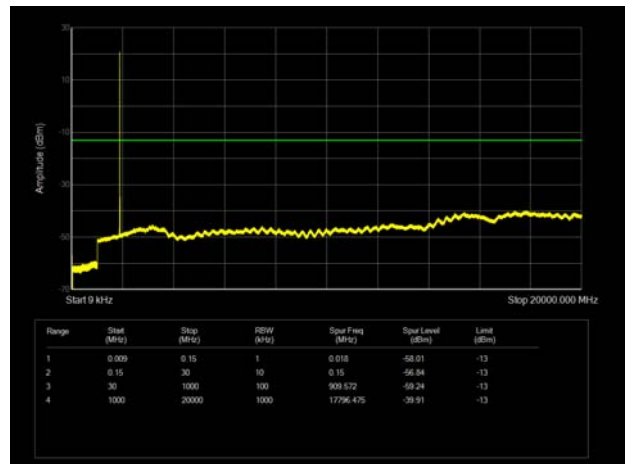

LTE Band 2 5MHz CH-High 9kHz~20GHz

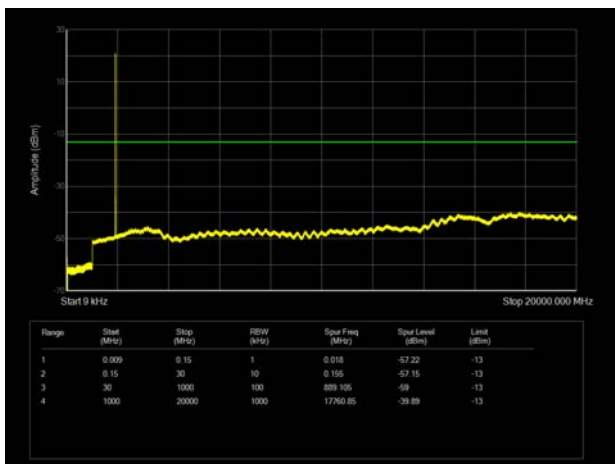

LTE Band 2 10MHz CH-High 9kHz~20GHz

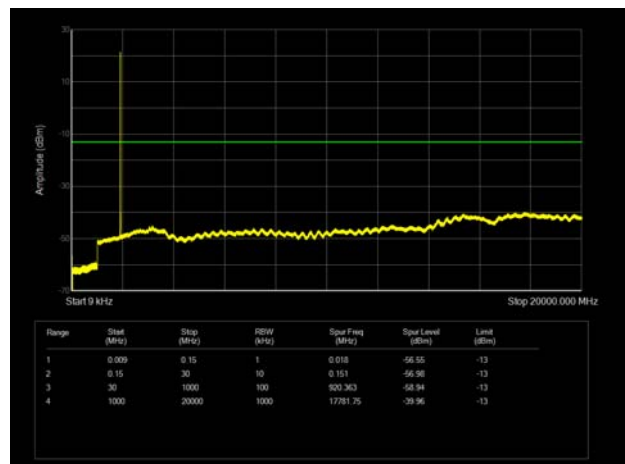

LTE Band 2 15MHz CH-Low 9kHz~20GHz

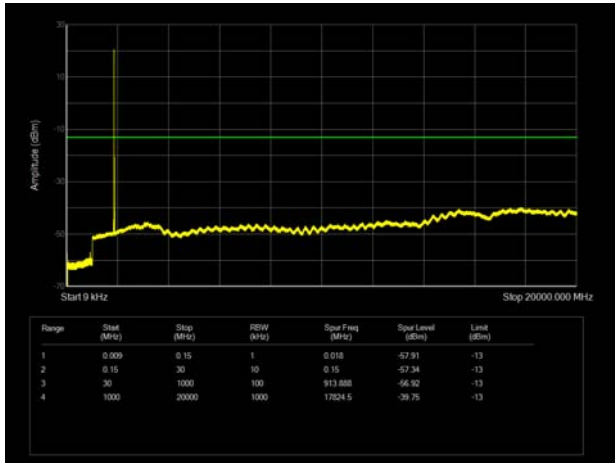

LTE Band 2 20MHz CH-Low 9kHz~20GHz

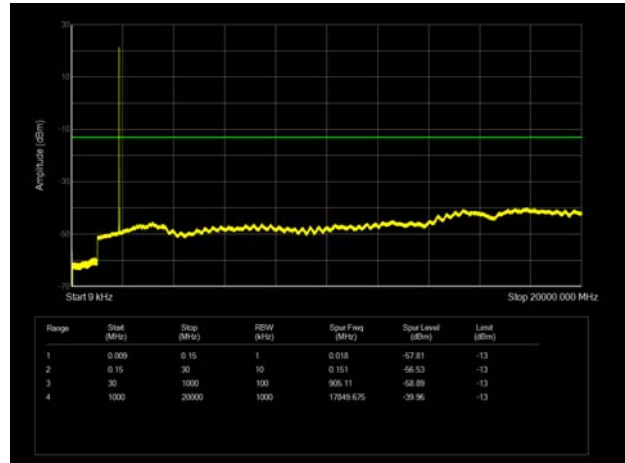

LTE Band 2 15MHz CH-Middle 9kHz~20GHz

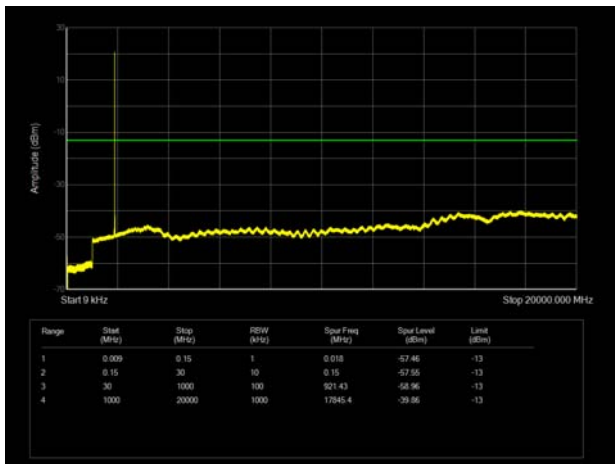

LTE Band 2 20MHz CH-Middle 9kHz~20GHz

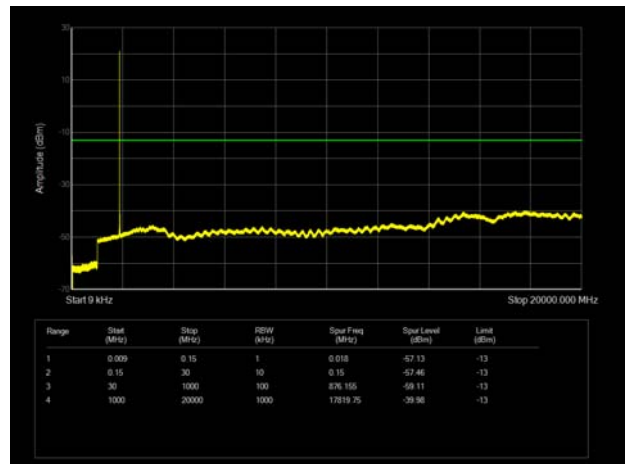

LTE Band 2 15MHz CH-High 9kHz~20GHz

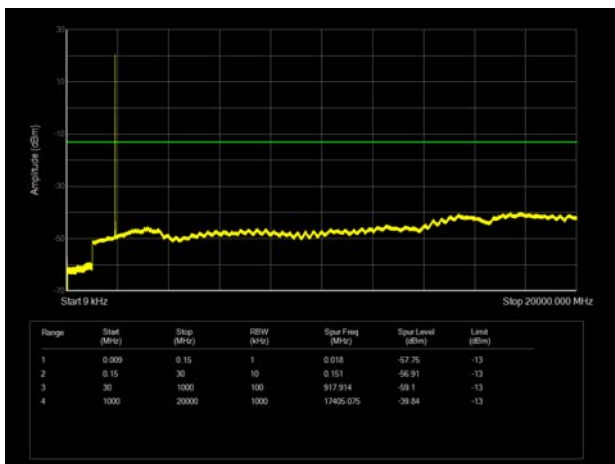

LTE Band 2 20MHz CH-High 9kHz~20GHz

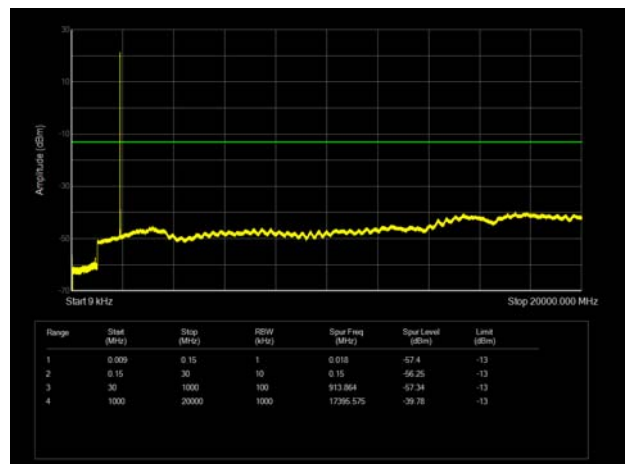

5.7. Radiates Spurious Emission

Ambient condition

Temperature	Relative humidity	Pressure
23°C ~25°C	45%~50%	101.5kPa

Method of Measurement

1. The testing follows FCC KDB 971168 v03r01 Section 5.8 and ANSI C63.26 (2015).
2. Below 1GHz: The EUT is placed on a turntable 0.8 meters above the ground in the chamber, 3 meter away from the antenna. The maximal emission value is acquired by adjusting the antenna height, polarisation and turntable azimuth. Normally, the height range of antenna is 1 m to 4 m, the azimuth range of turntable is 0° to 360°, and the receive antenna has two polarizations Vertical (V) and Horizontal (H). Above 1GHz: (Note: the FCC's permission to use 1.5m as an alternative per TCBC Conf call of Dec. 2, 2014.) The EUT is placed on a turntable 1.5 meters above the ground in the chamber, 3 meter away from the antenna. The maximal emission value is acquired by adjusting the antenna height, polarisation and turntable azimuth. Normally, the height range of antenna is 1 m to 4 m, the azimuth range of turntable is 0° to 360°, and the receive antenna has two polarizations Vertical (V) and Horizontal (H).
3. A loop antenna, A log-periodic antenna or horn antenna shall be substituted in place of the EUT. The log-periodic antenna will be driven by a signal generator and the level will be adjusted till the same power value on the spectrum analyzer or receiver. The level of the spurious emissions can be calculated through the level of the signal generator, cable loss, the gain of the substitution antenna and the reading of the spectrum analyzer or receiver.
4. The EUT is then put into continuously transmitting mode at its maximum power level during the test. Set Test Receiver or Spectrum RBW=1MHz, VBW=3MHz, and the maximum value of the receiver should be recorded as (Pr).
5. The EUT shall be replaced by a substitution antenna. In the chamber, an substitution antenna for the frequency band of interest is placed at the reference point of the chamber. An RF Signal source for the frequency band of interest is connected to the substitution antenna with a cable that has been constructed to not interfere with the radiation pattern of the antenna. A power (PMea) is applied to the input of the substitution antenna, and adjust the level of the signal generator output until the value of the receiver reach the previously recorded (Pr). The power of signal source (PMea) is recorded. The test should be performed by rotating the test item and adjusting the receiving antenna polarization.
6. A amplifier should be connected to the Signal Source output port. And the cable should be connect between the Amplifier and the Substitution Antenna. The cable loss (Pcl), the Substitution Antenna Gain (Ga) and the Amplifier Gain (PAg) should be recorded after test.
7. The measurement results are obtained as described below:
$$\text{Power(EIRP)} = \text{PMea} - \text{PAg} - \text{Pcl} + \text{Ga}$$
The measurement results are amend as described below:
$$\text{Power(EIRP)} = \text{PMea} - \text{Pcl} + \text{Ga}$$
8. This value is EIRP since the measurement is calibrated using an antenna of known gain (2.15 dB) and known input power. ERP can be calculated from EIRP by subtracting the gain of the dipole, ERP

= EIRP-2.15dB.

The modulation mode and RB allocation refer to section 5.1, using the maximum output power configuration.

Test setup

9KHz ~ 30MHz

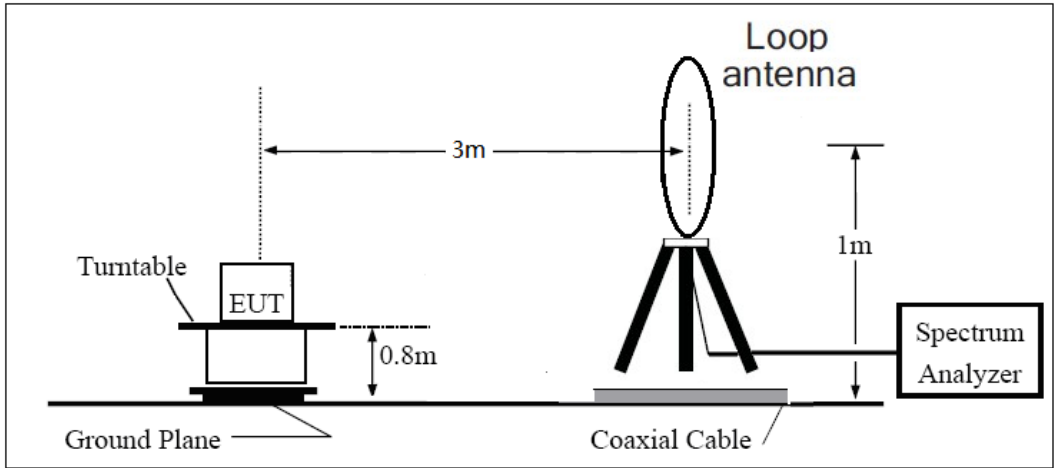

30MHz ~ 1GHz

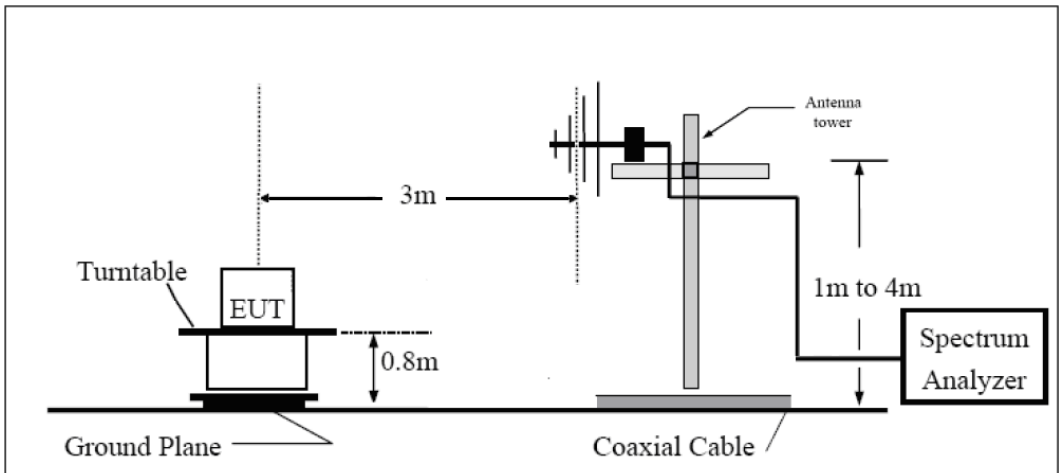

Above 1GHz

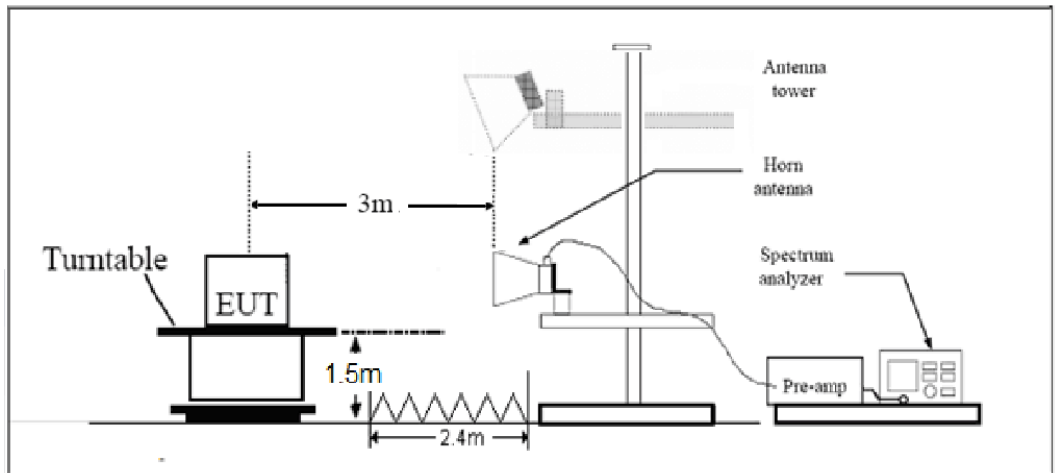

Note: Area side: 2.4mX3.6m

**Limits**

Rule Part 24.238(a) specifies that “on any frequency outside a licensee's frequency block, the power of any emission shall be attenuated below the transmitter power (P) by at least $43 + 10 \log_{10} (P)$ dB.”

Limit	-13 dBm
-------	---------

Measurement Uncertainty

The assessed measurement uncertainty to ensure 95% confidence level for the normal distribution is with the coverage factor $k = 1.96$, $U = 3.55$ dB.

Test Result

Sweep the whole frequency band through the range from 9kHz to the 10th harmonic of the carrier, the emissions below the noise floor will not be recorded in the report.

WCDMA Band II CH-Middle

Harmonic	Frequency (MHz)	SG (dBm)	Cable Loss (dB)	Gain (dBi)	Antenna Polarization	EIRP Level (dBm)	Limit (dBm)	Margin (dB)	Azimuth (deg)
2	3760.00	-65.92	2.60	12.50	Horizontal	-56.02	-13.00	43.02	315
3	5640.00	-64.33	3.30	12.50	Horizontal	-55.13	-13.00	42.13	90
4	7520.00	-57.43	4.20	12.20	Horizontal	-49.43	-13.00	36.43	45
5	9400.00	-54.38	4.30	11.10	Horizontal	-47.58	-13.00	34.58	225
6	11280.00	-50.51	5.90	11.90	Horizontal	-44.51	-13.00	31.51	90
7	13160.00	-51.73	5.70	14.00	Horizontal	-43.43	-13.00	30.43	45
8	15040.00	-53.87	5.80	13.10	Horizontal	-46.57	-13.00	33.57	315
9	16920.00	-50.19	6.10	14.60	Horizontal	-41.69	-13.00	28.69	90
10	18800.00	-	-	-	-	-	-	-	-

Note: 1.The other Spurious RF Radiated emissions level is no more than noise floor.
 2. The worst emission was found in the antenna is Horizontal position.

LTE Band 2 1.4MHz CH-Middle

Harmonic	Frequency (MHz)	SG (dBm)	Cable Loss (dB)	Gain (dBi)	Antenna Polarization	EIRP Level (dBm)	Limit (dBm)	Margin (dB)	Azimuth (deg)
2	3758.60	-66.76	2.60	12.50	Horizontal	-56.86	-13.00	43.86	45
3	5637.90	-64.74	3.30	12.50	Horizontal	-55.54	-13.00	42.54	225
4	7517.20	-59.40	4.20	12.20	Horizontal	-51.40	-13.00	38.40	0
5	9396.50	-55.27	4.30	11.10	Horizontal	-48.47	-13.00	35.47	180
6	11275.80	-50.33	5.90	11.90	Horizontal	-44.33	-13.00	31.33	315
7	13155.10	-53.40	5.70	14.00	Horizontal	-45.10	-13.00	32.10	90
8	15034.00	-53.38	5.80	13.10	Horizontal	-46.08	-13.00	33.08	180
9	16913.70	-55.10	6.10	14.60	Horizontal	-46.60	-13.00	33.60	45
10	18793.00	-	-	-	-	-	-	-	-

Note: 1.The other Spurious RF Radiated emissions level is no more than noise floor.
 2. The worst emission was found in the antenna is Horizontal position.

LTE Band 2 5MHz CH-Middle

Harmonic	Frequency (MHz)	SG (dBm)	Cable Loss (dB)	Gain (dBi)	Antenna Polarization	EIRP Level (dBm)	Limit (dBm)	Margin (dB)	Azimuth (deg)
2	3755.00	-66.41	2.60	12.50	Horizontal	-56.51	-13.00	43.51	225
3	5632.50	-66.00	3.30	12.50	Horizontal	-56.80	-13.00	43.80	315
4	7510.00	-58.96	4.20	12.20	Horizontal	-50.96	-13.00	37.96	135
5	9387.50	-55.11	4.30	11.10	Horizontal	-48.31	-13.00	35.31	225
6	11265.00	-52.12	5.90	11.90	Horizontal	-46.12	-13.00	33.12	45
7	13142.50	-53.77	5.70	14.00	Horizontal	-45.47	-13.00	32.47	180
8	15020.00	-53.63	5.80	13.10	Horizontal	-46.33	-13.00	33.33	315
9	16897.50	-51.51	6.10	14.60	Horizontal	-43.01	-13.00	30.01	90
10	18775.00	-	-	-	-	-	-	-	-

Note: 1.The other Spurious RF Radiated emissions level is no more than noise floor.
 2. The worst emission was found in the antenna is Horizontal position.

LTE Band 2 20MHz CH-Middle

Harmonic	Frequency (MHz)	SG (dBm)	Cable Loss (dB)	Gain (dBi)	Antenna Polarization	EIRP Level (dBm)	Limit (dBm)	Margin (dB)	Azimuth (deg)
2	3740.00	-64.24	2.60	12.50	Horizontal	-54.34	-13.00	41.34	135
3	5610.00	-65.13	3.30	12.50	Horizontal	-55.93	-13.00	42.93	45
4	7480.00	-57.83	4.20	12.20	Horizontal	-49.83	-13.00	36.83	225
5	9350.00	-54.28	4.30	11.10	Horizontal	-47.48	-13.00	34.48	180
6	11220.00	-52.72	5.90	11.90	Horizontal	-46.72	-13.00	33.72	0
7	13090.00	-53.26	5.70	14.00	Horizontal	-44.96	-13.00	31.96	315
8	14960.00	-52.44	5.80	13.10	Horizontal	-45.14	-13.00	32.14	90
9	16830.00	-48.71	6.10	14.60	Horizontal	-40.21	-13.00	27.21	270
10	18700.00	-	-	-	-	-	-	-	-

Note: 1.The other Spurious RF Radiated emissions level is no more than noise floor.
 2. The worst emission was found in the antenna is Horizontal position.

6. Main Test Instruments

Name	Manufacturer	Type	Serial Number	Calibration Date	Expiration Date
Base Station Simulator	R&S	CMW500	113645	2021-05-15	2022-05-14
Climate Chamber	Weiss	VT4002	58226119450010	2021-05-15	2022-05-14
Spectrum Analyzer	Keysight	N9020A	MY52330084	2021-05-15	2022-05-14
Universal Radio Communication Tester	Key sight	E5515C	GB44400275	2021-05-15	2022-05-14
Signal Analyzer	R&S	FSV3030	101411	2020-12-13	2021-12-12
				2021-12-12	2022-12-12
Signal Analyzer	R&S	FSV30	100815	2020-12-17	2021-12-16
				2021-12-12	2022-12-11
TRILOG Broadband Antenna	Schwarzbeck	VULB 9163	01439	2021-06-30	2024-06-29
Loop Antenna	SCHWARZBECK	FMZB1519	1519-047	2020-04-02	2023-04-01
TRILOG Broadband Antenna	Schwarzbeck	VULB 9163	01439	2021-06-30	2024-06-29
Horn Antenna	R&S	HF907	102723	2020-08-11	2023-08-10
Horn Antenna	ETS-Lindgren	3160-09	00102643	2021-10-10	2024-10-09
Horn Antenna	STEATITE	QSH-SL-26-40-K-15	16779	2019-12-24	2022-12-23
Software	R&S	EMC32	9.26.0	/	/

*****END OF REPORT *****



ANNEX A: The EUT Appearance

The EUT Appearance are submitted separately.



ANNEX B: Test Setup Photos

The Test Setup Photos are submitted separately.