

TEST REPORT

Report No.: SRTC2021-9003(F)-0022
Product Name: ZTE True Wireless In-Ear Headphone
Mode Name: EB64G
Applicant: ZTE Corporation
Manufacturer: ZTE Corporation
Specification: FCC Part15B (Certification)
(2020 edition)
ANSI C63.4-2014
FCC ID: SRQ-EB64G

The State Radio_monitoring_center Testing Center (SRTC)
15th Building, No.30 Shixing Street, Shijingshan District,
Beijing, China

Tel: 86-10-57996183 Fax: 86-10-57996388

CONTENTS

1. General information	3
1.1 Notes of the test report.....	3
1.2 Information about the testing laboratory	3
1.3 Applicant's details.....	3
1.4 Manufacturer's details	3
1.5 Application details.....	3
1.6 Reference specification	4
1.7 Information of EUT	4
1.7.1 General information	4
1.7.2 EUT details.....	5
1.7.3 Auxiliary equipment details.....	5
2. Test information	6
2.1 Summary of the test results.....	6
2.2 Test result	7
2.2.1 Conducted Emissions-FCC Part15.107.....	7
2.2.2 Radiated Emissions-FCC Part15.109.....	10
2.3. List of test equipments	14

1. General information

1.1 Notes of the test report

The test report may only be reproduced or published in full. Reproduction or publication of extracts from the report requires the prior written permission of The State Radio_monitoring_center Testing Center (SRTC).

The test results relate only to individual items of the samples which have been tested.

1.2 Information about the testing laboratory

Company: The State Radio_monitoring_center Testing Center (SRTC)
Address: 15th Building, No.30 Shixing Street, Shijingshan District
Testing location: No.80, Zhaojiachang, BeizangCun, Daxing District, Beijing, China.
City: Beijing
Country or Region: China
Contacted person: Liu Jia
Tel: +86 10 57996183
Fax: +86 10 57996388
Email: liujiaf@srtc.org.cn

1.3 Applicant's details

Company: ZTE Corporation
Address: ZTE Plaza, Keji Road South, Hi-Tech Industrial Park,Nanshan District, Shenzhen, Guangdong Province 518057, P. R. China
City: Shenzhen
Country or Region: China
Contacted person: Wenge Wang
Tel: +86 15999501007
Email: wang.wenge@zte.com.cn

1.4 Manufacturer's details

Company: ZTE Corporation
Address: ZTE Plaza, Keji Road South, Hi-Tech Industrial Park,Nanshan District, Shenzhen, Guangdong Province 518057, P. R. China
City: Shenzhen
Country or Region: China
Contacted person: Wenge Wang
Tel: +86 15999501007
Email: wang.wenge@zte.com.cn

1.5 Application details

Date of reception of test sample: 19th Jul. 2021

Date of test: 19th Jul. 2021 to 4th Aug. 2021

1.6 Reference specification

FCC Part 15B, 2020 (Certification)

1.7 Information of EUT

1.7.1 General information

Product Name of EUT	ZTE True Wireless In-Ear Headphone
Mode Name	EB64G
FCC ID	SRQ-EB64G
Frequency Range	Bluetooth: 2.4~2.4835GHz
Power Supply	Battery
Nominal Voltage	3.8V
Extreme Temperature	Lowest: -10°C Highest: +45°C
Extreme Voltage	Minimum: 3.1V Maximum: 4.2V
HW Version	V2
SW Version	1.0.1.0

1.7.2 EUT details

No.	Product Name	Mode Name	IMEI
EUT	ZTE True Wireless In-Ear Headphone	EB64G	---

1.7.3 Auxiliary equipment details

AE (Auxiliary Equipment) 1#: Battery

Manufacturer	JUHEYUAN SCIENCE & TECHNOLOGY CO., LTD.
Model Number	JHY1054

AE (Auxiliary Equipment) 2#: Battery

Manufacturer	JUHEYUAN SCIENCE & TECHNOLOGY CO., LTD.
Model Number	JHY902030

Note: The AE1 is the Battery for the HeadPhone while the AE2 is the Battery for the charger case.

2. Test information

2.1 Summary of the test results

No.	Test case	FCC reference	Verdict
1	Conducted emissions	15.107	Pass
2	Radiated emissions	15.109	Pass

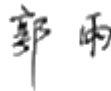
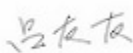
Approved By: Mr.Liu Wei Director of the test department 	Checked By: Mr.Guo Yu Vice director of the test department 
Tested by: Mr. Lv Youyou Test engineer 	Issued date: 2021.08.09

2.2 Test result

2.2.1 Conducted Emissions-FCC Part15.107

Ambient condition:

Temperature	Relative humidity	Pressure
23.5°C	40.2%	100.8kPa

Test Setup with laptop:

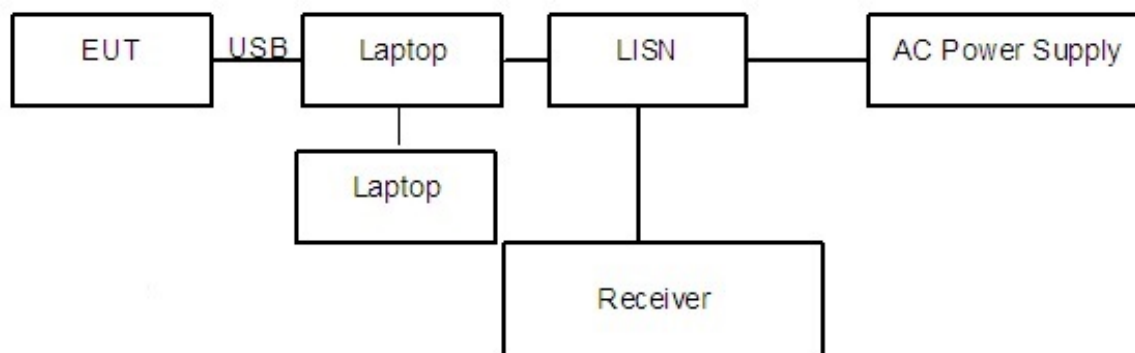

Figure 1

Test Procedure:

The EUT is placed on a non-metallic table 0.8m above the horizontal metal reference ground plane. The accessories of the EUT are connected with the EUT. The EUT was connected with a laptop via the USB cable and was charged. The laptop's LAN port is connected with another laptop via cable. And the data transferring between two laptops is maintained.

The AC main power supply of the laptop is connected to LISN and LISN is connected to the reference ground. The test set-up and the test methods are performed according to ANSI C63.4:2014.

Then start the test software EMC32. Sweep the whole frequency band through the range from 150 KHz to 30 MHz with RBW 9kHz, VBW 30kHz. The measurement should be done for both L line and N line. During pre-test, the receiver uses both peak detector and average detector. And the final test, the receiver uses both average detector and Quasi-peak detector.

The data of cable loss has been calibrated in full testing frequency range before the testing.

A “reference path loss” Corr.(dB) is established and the $L_{\text{cable}}+\text{ATT}+\text{VDF}$ is the attenuation of “reference path loss”, and including the cable loss, the attenuation of the attenuator, the voltage division factor of AMN.

The measurement results are obtained as described below:

$$P_{\text{result}}=P_{\text{mea}}+\text{Corr.}(\text{dB})$$

Sample calculation: $(36.08\text{dB}\mu\text{V}) = (6.38 \text{dB}\mu\text{V}) + (29.7 \text{dB})$, the corresponding frequency is 0.312043MHz.

Limit:

Frequency of Emission(MHz)	Limits(dB μ V)	
	Quasi-peak	Average
0.15~0.5	66 to 56*	56 to 46*
0.5~5	56	46
5~30	60	50

Note: * Decreases with the logarithm of the frequency

Test result:

Noise Level of the Measuring Instrument

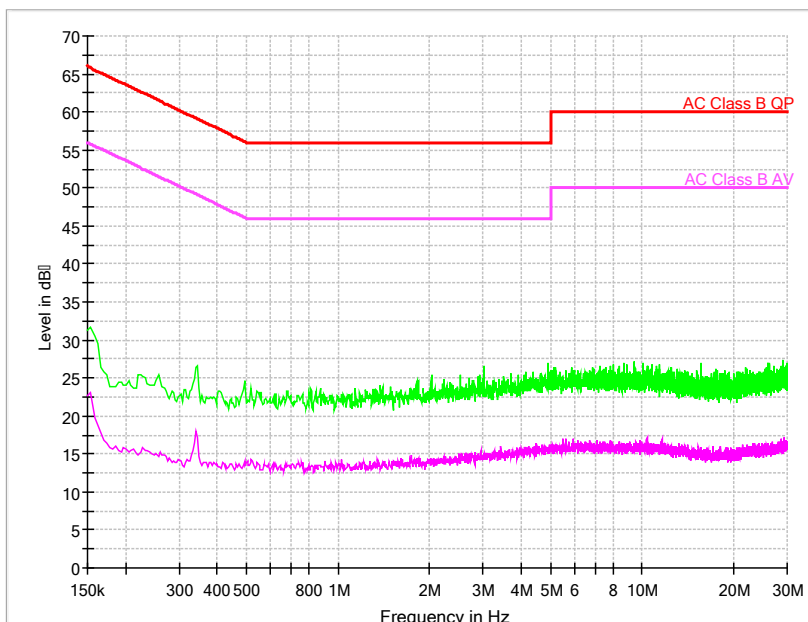

Pic1. Conducted emission L and N Line

EUT+Laptop:

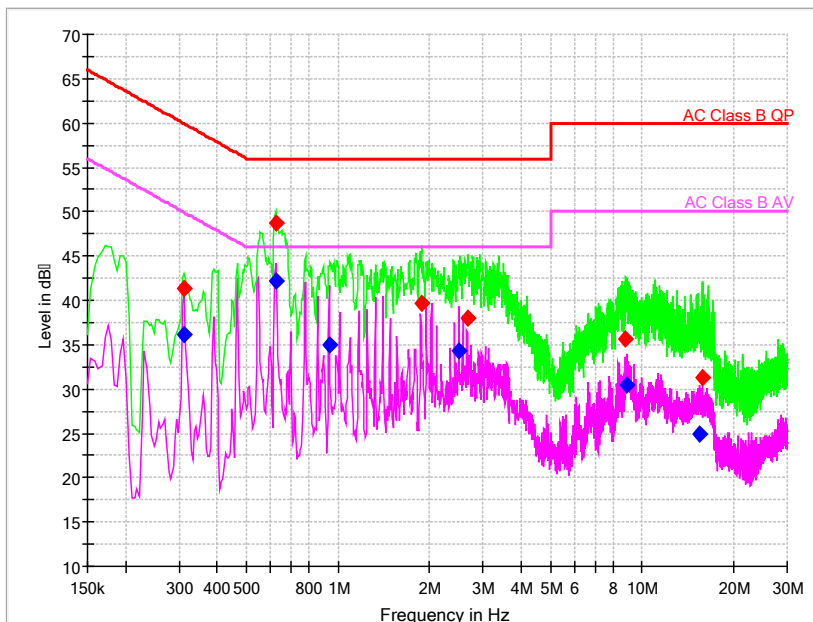

Pic2. Conducted emission L&N Line Voltage: 120VAC

Frequency (MHz)	QuasiPeak (dB μ V)	Average (dB μ V)	Limit (dB μ V)	Margin (dB)	Line	Corr. (dB)	P _{mea} QuasiPeak (dB μ V)	P _{mea} Average (dB μ V)
0.312043	---	36.08	49.92	13.84	L1	29.7	---	6.38
0.312043	41.37	---	59.92	18.54	L1	29.7	11.67	---
0.623336	---	42.24	46.00	3.76	L1	29.7	---	12.54
0.623336	48.67	---	56.00	7.33	L1	29.7	18.97	---
0.934629	---	35.03	46.00	10.97	L1	29.8	---	5.23
1.885564	39.66	---	56.00	16.34	L1	29.8	9.86	---
2.499621	---	34.26	46.00	11.74	L1	29.8	---	4.46
2.678721	37.99	---	56.00	18.01	L1	29.8	8.19	---
8.849143	35.73	---	60.00	24.27	L1	29.9	5.83	---
8.904579	---	30.38	50.00	19.62	L1	29.9	---	0.48
15.411879	---	24.92	50.00	25.08	L1	30.1	---	-5.18
15.753021	31.34	---	60.00	28.66	N	30.1	1.24	---

2.2.2 Radiated Emissions-FCC Part15.109

Ambient condition:

Temperature	Relative humidity	Pressure
23.6°C	41.5%	100.8kPa

Test Setup:

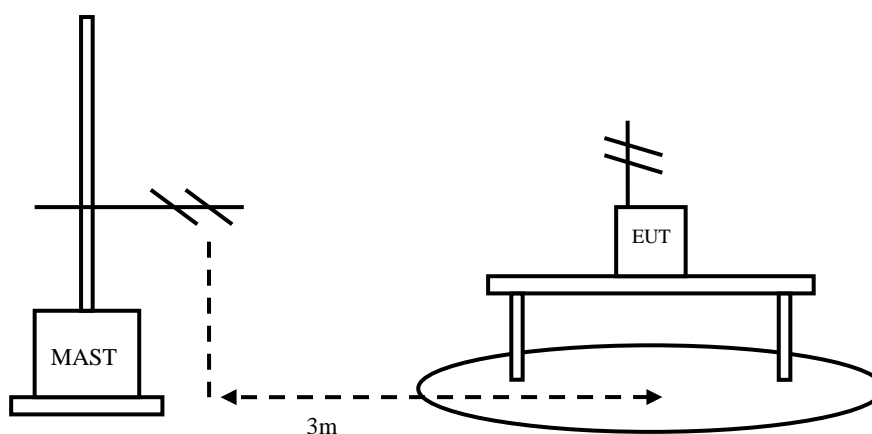

Figure 2

Test Procedure:

EUT+Laptop:

The EUT should be placed on a non-metallic table 80cm above the ground plane. The receive antennas shall be moved from 1 to 4 meters. The distance between EUT and receive antenna should be 3 meters.

The accessories of the EUT are connected with the EUT. The EUT was connected with a laptop via the USB cable. The test set-up and the test methods are performed according to ANSI C63.4:2014

Then start the test software EMC32. Sweep the whole frequency band through the range from 30MHz to 1GHz, using receive log period antenna VULB 9163.

During the test, the height of receive antenna shall be moved from 1 to 4 meters, and the antenna shall be performed under horizontal and vertical polarization. The turn table shall be rotated from 0 to 360 degrees for detecting the maximum of radiated spurious signal level. The measurements shall be repeated with orthogonal polarization of the test antenna. The EUT is laid in two modes as follow: 1. put the EUT in horizontal direction; 2. put the EUT in vertical direction.

The data of cable loss and antenna factor have been calibrated in full testing frequency range before the testing.

RBW=120kHz, VBW=300kHz, when the test frequency: 30MHz<f<1GHz

RBW=1MHz, VBW=3MHz, when the test frequency: f>1GHz

A “reference path loss” is established and the A_{Rpl} is the attenuation of “reference path loss”, and including the gain of receive antenna, the gain of the preamplifier, the cable loss.

The measurement results are obtained as described below:

$$\text{Result} = P_{\text{mea}} + A_{Rpl}$$

Sample calculation: (7.26 dB μ V/m) = (25.16 dB μ V) + (-17.9dB/m), the corresponding frequency is 45.132000MHz.

Limit:

Frequency of Emission(MHz)	Limits	
	Detector	Unit (dB μ V/m)
30~88	Quasi-peak	40
88~216	Quasi-peak	43.5
216~960	Quasi-peak	46
960~1000	Quasi-peak	54
1000~5th harmonic of the highest frequency or 40GHz, whichever is lower	Average	54
	Peak	74

Test result:

EUT+Laptop:

Frequency(MHz)	Result(dBuV/m)	A_{Rpl} (dB/m)	P_{mea} (dBuV)	Polarity
45.132000	7.26	-17.9	25.16	V
55.802000	5.26	-18.3	23.56	V
138.009500	14.64	-22.7	37.34	V
200.574500	8.39	-19.1	27.49	V
499.722500	19.39	-10.8	30.19	V
732.862000	16.30	-6.0	22.30	V

EUT+ Laptop: refer to Pic3 to Pic6

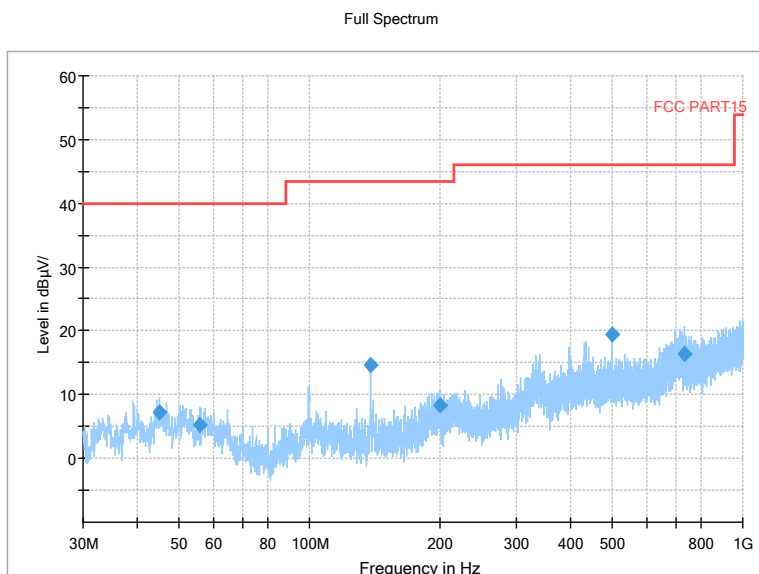

Pic3. Radiated emission (30MHz – 1GHz)

Note: The test data in the graph includes two polarizations: horizontal and vertical

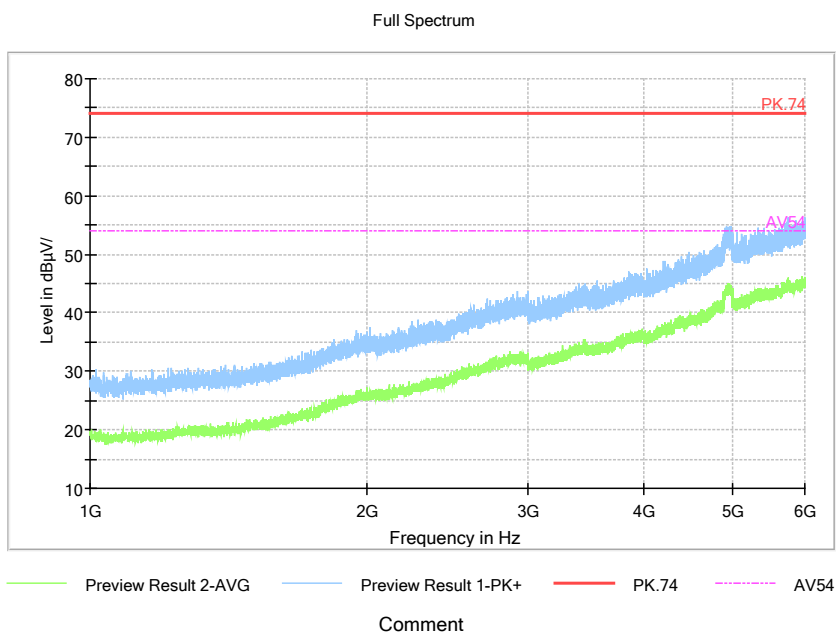

Pic4. Radiated emission (1GHz –6GHz)

Note: The test data in the graph includes two polarizations: horizontal and vertical

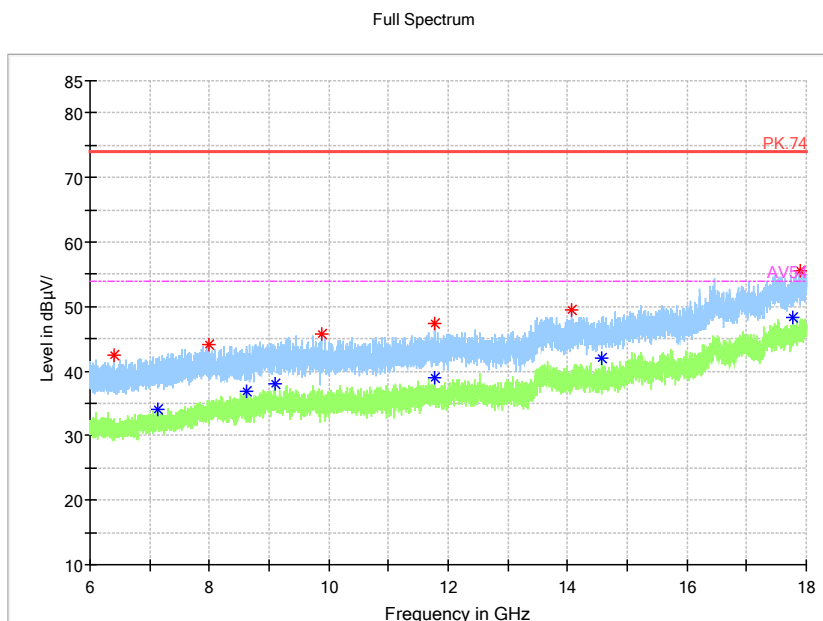

Pic5. Radiated emission (6GHz –18GHz)

Note: The test data in the graph includes two polarizations: horizontal and vertical

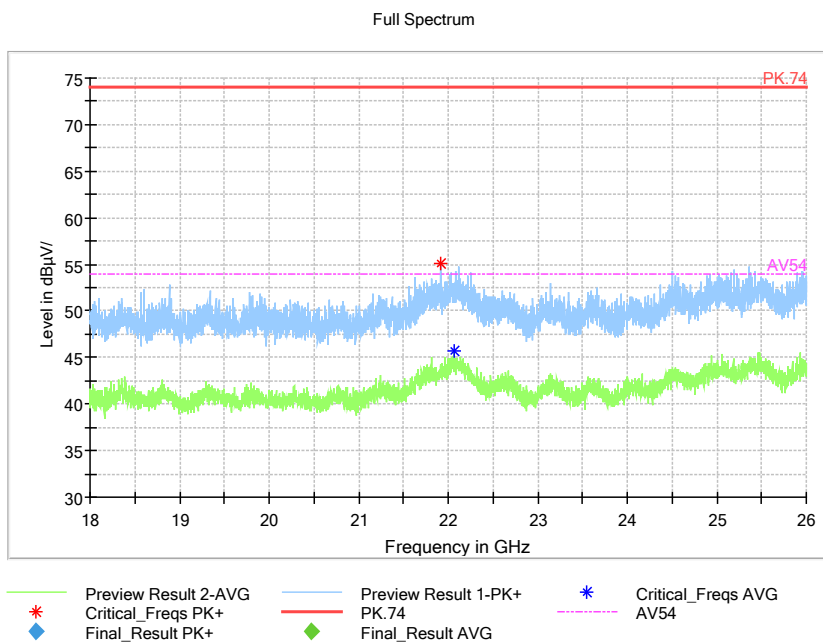

Pic6. Radiated emission (18GHz –26GHz)

Note: The test data in the graph includes two polarizations: horizontal and vertical

2.3. List of test equipments

No.	Name/Model	Manufacturer	S/N	Calibration Due Date	Calibration Date
1	23.18m×16.88m×9.60mS emi-AnechoicChamber	FRANKONIA	-----	2021.09.05	2016.09.06
2	ESW EMI test receiver	R&S	101574	2021.08.19	2020.08.20
3	ESR3 EMI test receiver	R&S	102361	2022.04.11	2021.04.12
4	9.080m×5.255m×3.525m Shielding room	FRANKONIA	-----	2021.09.05	2016.09.06
5	VULB 9163 Ultra log test antenna	schwarzbeck	867	2022.03.24	2021.03.25
6	HF 907 Double-Ridged Waveguide Horn Antenna	R&S	100512	2022.03.24	2021.03.25
7	SAS-574 Horn Antenna	schwarzbeck	535	2021.08.19	2020.08.20
8	ENV216 AMN	R&S	3560.6550. 12	2021.08.19	2020.08.20
9	EMC32EMI test software	R&S	-----	-----	-----

-----The end-----