



RF TEST REPORT

Applicant ZTE Corporation

FCC ID SRQ-DL2XL

Product LTE/WCDMA/GSM(GPRS) Multi-Mode
Digital Mobile Phone

Model ZTE BLADE A602、 ZTE Blade A602、
BLADE A602、 Blade A602、 DL2 XL、
Digicel DL2 XL、 DIGICEL DL2 XL

Report No. RXA1710-0342RF03

Issue Date October 28, 2017

TA Technology (Shanghai) Co., Ltd. tested the above equipment in accordance with the requirements in **FCC CFR47 Part 2 (2017)/ FCC CFR47 Part 27C (2017)**. The test results show that the equipment tested is capable of demonstrating compliance with the requirements as documented in this report.

Jiang peng Lan

Performed by: Jiangpeng Lan

Kai Xu

Approved by: Kai Xu

TA Technology (Shanghai) Co., Ltd.

No.145, Jintang Rd, Tangzhen Industry Park, Pudong Shanghai, China

TEL: +86-021-50791141/2/3

FAX: +86-021-50791141/2/3-8000

Table of Contents

1	Test Laboratory.....	4
1.1	Notes of the Test Report.....	4
1.2	Test facility.....	4
1.3	Testing Location.....	5
2	General Description of Equipment under Test.....	6
2.1	Applied Standards.....	7
3	Test Configuration.....	8
4	Test Information.....	9
4.1	RF Power Output.....	9
4.2	Effective Isotropic Radiated Power.....	12
4.3	Occupied Bandwidth.....	17
4.4	Band Edge Compliance.....	23
4.5	Peak-to-Average Power Ratio (PAPR).....	31
4.6	Frequency Stability.....	33
4.7	Spurious Emissions at Antenna Terminals.....	36
4.8	Radiates Spurious Emission.....	43
5	Main Test Instruments.....	51
ANNEX A: EUT Appearance and Test Setup.....		52
A.1	EUT Appearance.....	52
A.2	Test Setup.....	55

Summary of Measurement Results

Number	Test Case	Clause in FCC rules	Verdict
1	RF power output	2.1046	PASS
2	Effective Isotropic Radiated power	27.50(b)(10) 27.50(c) (10)	PASS
3	Occupied Bandwidth	2.1049	PASS
4	Band Edge Compliance	/27.53(g)	PASS
5	Peak-to-Average Power Ratio	27.50(d)/KDB971168 D01(5.7)	PASS
6	Frequency Stability	2.1055 / 27.54	PASS
7	Spurious Emissions at Antenna Terminals	2.1051 /27.53(f)/ /27.53(g)	PASS
8	Radiates Spurious Emission	/27.53(f)	PASS
Date of Testing: August 4, 2017~August 14, 2017			
Note: PASS: The EUT complies with the essential requirements in the standard. FAIL: The EUT does not comply with the essential requirements in the standard.			

1 Test Laboratory

1.1 Notes of the Test Report

This report shall not be reproduced in full or partial, without the written approval of **TA technology (shanghai) co., Ltd.** The results documented in this report apply only to the tested sample, under the conditions and modes of operation as described herein .Measurement Uncertainties were not taken into account and are published for informational purposes only. This report is written to support regulatory compliance of the applicable standards stated above. This report must not be used by the client to claim product certification, approval, or endorsement by any government agencies.

1.2 Test facility

CNAS (accreditation number: L2264)

TA Technology (Shanghai) Co., Ltd. has obtained the accreditation of China National Accreditation Service for Conformity Assessment (CNAS).

FCC (recognition number is 428261)

TA Technology (Shanghai) Co., Ltd. has been listed on the US Federal Communications Commission list of test facilities recognized to perform electromagnetic emissions measurements.

IC (recognition number is 8510A)

TA Technology (Shanghai) Co., Ltd. has been listed by industry Canada to perform electromagnetic emission measurement.

VCCI (recognition number is C-4595, T-2154, R-4113, G-10766)

TA Technology (Shanghai) Co., Ltd. has been listed by industry Japan to perform electromagnetic emission measurement.

A2LA (Certificate Number: 3857.01)

TA Technology (Shanghai) Co., Ltd. has been listed by American Association for Laboratory Accreditation to perform electromagnetic emission measurement.

1.3 Testing Location

Company: TA Technology (Shanghai) Co., Ltd.
Address: No.145, Jintang Rd, Tangzhen Industry Park, Pudong Shanghai, China
City: Shanghai
Post code: 201201
Country: P. R. China
Contact: Xu Kai
Telephone: +86-021-50791141/2/3
Fax: +86-021-50791141/2/3-8000
Website: <http://www.ta-shanghai.com>
E-mail: xukai@ta-shanghai.com

2 General Description of Equipment under Test

Client Information

Applicant	ZTE Corporation
Applicant address	ZTE Plaza, Keji Road South, Hi-Tech, Industrial Park, Nanshan District, Shenzhen, Guangdong, 518057, P.R.China
Manufacturer	ZTE Corporation
Manufacturer address	ZTE Plaza, Keji Road South, Hi-Tech, Industrial Park, Nanshan District, Shenzhen, Guangdong, 518057, P.R.China

General information

EUT Description			
Model:	ZTE BLADE A602、 ZTE Blade A602、 BLADE A602、 Blade A602、 DL2 XL、 Digicel DL2 XL、 DIGICEL DL2 XL		
IMEI	866112030002287		
Hardware Version:	MB V1.0		
Software Version:	DIG_JM_DL2XL_V1.0		
Power Supply:	Battery/AC adapter		
Antenna Type:	Internal Antenna		
Test Mode(s):	LTE Band 13; LTE Band 17		
Maximum E.I.R.P	LTE Band 13:	16.73 dBm	
	LTE Band 17:	16.23 dBm	
Rated Power Supply Voltage:	3.8V		
Extreme Voltage:	Minimum: 3.4V Maximum: 4.35V		
Extreme Temperature:	Lowest: -10°C Highest: +55°C		
Operating Frequency Range(s)	Mode	Tx (MHz)	Rx (MHz)
	LTE Band 13	777 ~ 787	746 ~ 756
	LTE Band 17	704 ~ 716	734 ~ 746
EUT Accessory			
Battery	Manufacturer: DOKOCOM Model: LPL-A008050150Z Input: 100-240V ac 50/60Hz 250mA MAX Output: 5V dc 1500mA		
Adapter	Manufacturer: BAK Model: Li3830T43P6h856337		
Earphone	Manufacturer: FDC Model: DEM-93		
USB	70cm Cable, Shielded		
Note: 1. The information of the EUT is declared by the manufacturer.			

2.1 Applied Standards

According to the specifications of the manufacturer, it must comply with the requirements of the following standards:

Test standards

FCC CFR47 Part 2 (2017)

FCC CFR47 Part 27C (2017)

ANSI C63.26 (2015)

KDB 971168 D01 Power Meas License Digital Systems v02r02

3 Test Configuration

Radiated measurements are performed by rotating the EUT in three different orthogonal test planes. EUT stand-up position (Z axis), lie-down position (X, Y axis). Receiver antenna polarization (horizontal and vertical), the worst emission was found in position (Z axis, vertical polarization) and the worst case was recorded.

All mode and data rates and positions and RB size and modulations were investigated. Subsequently, only the worst case emissions are reported.

The following testing in LTE is set based on the maximum RF Output Power.

The following testing in different Bandwidth is set to detail in the following table:

Test modes are chosen to be reported as the worst case configuration below for LTE Band 13/17

Test items	Modes	Bandwidth (MHz)		Modulation		RB			Test Channel		
		5	10	QPSK	16QAM	1	50%	100%	L	M	H
RF power output	LTE 13	O	O	O	O	O	O	O	O	O	O
	LTE 17	O	O	O	O	O	O	O	O	O	O
Effective Isotropic Radiated power	LTE 13	O	O	O	O	-	-	O	O	O	O
	LTE 17	O	O	O	O	-	-	O	O	O	O
Occupied Bandwidth	LTE 13	O	O	O	O	-	-	O	O	O	O
	LTE 17	O	O	O	O	-	-	O	O	O	O
Band Edge Compliance	LTE 13	O	O	O	O	O	-	O	O	-	O
	LTE 17	O	O	O	O	O	-	O	O	-	O
Peak-to-Average Power Ratio	LTE 13	O	O	O	O	-	-	O	O	O	O
	LTE 17	O	O	O	O	-	-	O	O	O	O
Frequency Stability	LTE 13	O	O	O	O	-	-	O	-	O	-
	LTE 17	O	O	O	O	-	-	O	-	O	-
Spurious Emissions at Antenna Terminals	LTE 13	O	O	O	-	O	-	-	O	O	O
	LTE 17	O	O	O	-	O	-	-	O	O	O
Radiates Spurious Emission	LTE 13	O	O	O	-	O	-	-	O	O	O
	LTE 17	O	O	O	-	O	-	-	O	O	O
Note	1. The mark "O" means that this configuration is chosen for testing. 2. The mark "-" means that this configuration is not testing.										

4 Test Information

4.1 RF Power Output

Ambient condition

Temperature	Relative humidity	Pressure
23°C ~25°C	45%~50%	101.5kPa

Methods of Measurement

During the process of the testing, The EUT is controlled by the Base Station Simulator to ensure max power transmission and proper modulation.

Test Setup

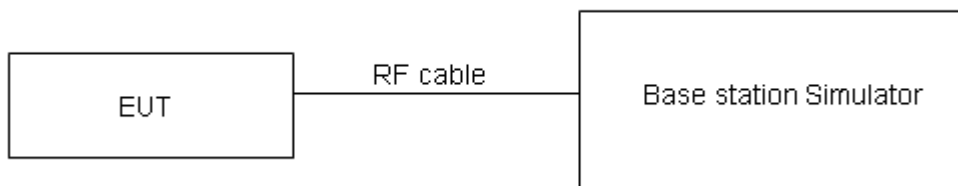

The loss between RF output port of the EUT and the input port of the tester has been taken into consideration.

Limits

No specific RF power output requirements in part 2.1046.

Measurement Uncertainty

The assessed measurement uncertainty to ensure 95% confidence level for the normal distribution is with the coverage factor $k = 2$, $U=0.4$ dB.



Test Results

LTE FDD Band 13				Conducted Power(dBm)		
Bandwidth	Modulation	RB size	RB offset	Channel/Frequency (MHz)		
				23205/779.5	23230/782	23255/784.5
5MHz	QPSK	1	0	21.27	21.20	21.24
		1	13	21.23	21.22	21.21
		1	24	21.18	21.15	21.17
		12	0	20.32	20.26	20.24
		12	6	20.29	20.25	20.27
		12	13	20.22	20.30	20.21
		25	0	20.20	20.18	20.17
	16QAM	1	0	20.29	20.29	20.20
		1	13	20.27	20.24	20.25
		1	24	20.39	20.36	20.32
		12	0	19.29	19.25	19.26
		12	6	19.27	19.27	19.24
		12	13	19.23	19.24	19.21
		25	0	19.18	19.26	19.15
Bandwidth	Modulation	RB size	RB offset	Channel/Frequency (MHz)		
				/	23230/782	/
10MHz	QPSK	1	0	/	21.30	/
		1	25	/	21.35	/
		1	49	/	21.22	/
		25	0	/	20.20	/
		25	13	/	20.25	/
		25	25	/	20.26	/
		50	0	/	20.28	/
	16QAM	1	0	/	20.28	/
		1	25	/	20.31	/
		1	49	/	20.14	/
		25	0	/	19.31	/
		25	13	/	19.24	/
		25	25	/	19.20	/
		50	0	/	19.27	/

LTE FDD Band 17				Conducted Power(dBm)		
Bandwidth	Modulation	RB size	RB offset	Channel/Frequency (MHz)		
				23755/706.5	23790/710	23825/713.5
5MHz	QPSK	1	0	21.74	21.82	21.70
		1	13	21.69	21.74	21.64
		1	24	21.78	21.79	21.77
		12	0	20.69	20.75	20.75
		12	6	20.73	20.77	20.79
		12	13	20.85	20.87	20.81
		25	0	20.72	20.84	20.86
	16QAM	1	0	20.98	21.01	20.95
		1	13	20.90	20.84	20.95
		1	24	20.95	20.96	20.98
		12	0	20.05	20.09	20.06
		12	6	20.05	20.12	20.06
		12	13	20.10	20.08	20.12
		25	0	20.10	20.19	20.07
Bandwidth	Modulation	RB size	RB offset	Channel/Frequency (MHz)		
				23780/709	23790/710	23800/711
10MHz	QPSK	1	0	21.72	21.75	21.68
		1	25	21.69	21.74	21.63
		1	49	21.75	21.77	21.73
		25	0	20.67	20.71	20.72
		25	13	20.71	20.73	20.76
		25	25	20.81	20.83	20.78
		50	0	20.75	20.77	20.81
	16QAM	1	0	20.93	20.98	20.90
		1	25	20.87	20.83	20.92
		1	49	20.93	20.91	20.96
		25	0	20.02	20.08	20.04
		25	13	20.01	20.09	20.02
		25	25	20.08	20.04	20.09
		50	0	20.08	20.15	20.04

4.2 Effective Isotropic Radiated Power

Ambient condition

Temperature	Relative humidity	Pressure
23°C ~25°C	45%~50%	101.5kPa

Methods of Measurement

- The testing follows ANSI C63.26 (2015) Section 5.5.2.3.
- Above 30MHz: The EUT is placed on a turntable 0.8 meters above the ground in the chamber, 3 meter away from the antenna. The maximal emission value is acquired by adjusting the antenna height, polarisation and turntable azimuth. Normally, the height range of antenna is 1 m to 4 m, the azimuth range of turntable is 0° to 360°, and the receive antenna has two polarizations Vertical (V) and Horizontal (H). Above 1GHz: (Note: the FCC's permission to use 1.5m as an alternative per TCBC Conf call of Dec. 2, 2014.) The EUT is placed on a turntable 1.5 meters above the ground in the chamber, 3 meter away from the antenna. The maximal emission value is acquired by adjusting the antenna height, polarisation and turntable azimuth. Normally, the height range of antenna is 1 m to 4 m, the azimuth range of turntable is 0° to 360°, and the receive antenna has two polarizations Vertical (V) and Horizontal (H).
- A log-periodic antenna or double-ridged waveguide horn antenna shall be substituted in place of the EUT. The log-periodic antenna will be driven by a signal generator and the level will be adjusted till the same power value on the spectrum analyzer or receiver. The level of the spurious emissions can be calculated through the level of the signal generator, cable loss, the gain of the substitution antenna and the reading of the spectrum analyzer or receiver.
- The EUT is then put into continuously transmitting mode at its maximum power level during the test. Set Test Receiver or Spectrum RBW=1MHz, VBW=3MHz, And the maximum value of the receiver should be recorded as (Pr).
- The EUT shall be replaced by a substitution antenna. In the chamber, an substitution antenna for the frequency band of interest is placed at the reference point of the chamber. An RF Signal source for the frequency band of interest is connected to the substitution antenna with a cable that has been constructed to not interfere with the radiation pattern of the antenna. A power (PMea) is applied to the input of the substitution antenna, and adjust the level of the signal generator output until the value of the receiver reach the previously recorded (Pr). The power of signal source (PMea) is recorded. The test should be performed by rotating the test item and adjusting the receiving antenna polarization.
- A amplifier should be connected to the Signal Source output port. And the cable should be connect between the Amplifier and the Substitution Antenna. The cable loss (Pcl) ,the Substitution Antenna Gain (Ga) and the Amplifier Gain (PAg) should be recorded after test.
- The measurement results are obtained as described below:

$$\text{Power(EIRP)} = \text{PMea} - \text{PAg} - \text{Pcl} + \text{Ga}$$
The measurement results are amend as described below:

$$\text{Power(EIRP)} = \text{PMea} - \text{Pcl} + \text{Ga}$$
- This value is EIRP since the measurement is calibrated using an antenna of known gain (2.15 dBi) and known input power. ERP can be calculated from EIRP by subtracting the gain of the dipole, $\text{ERP} = \text{EIRP} - 2.15\text{dBi}$.

Test setup

30MHz~~~ 1GHz

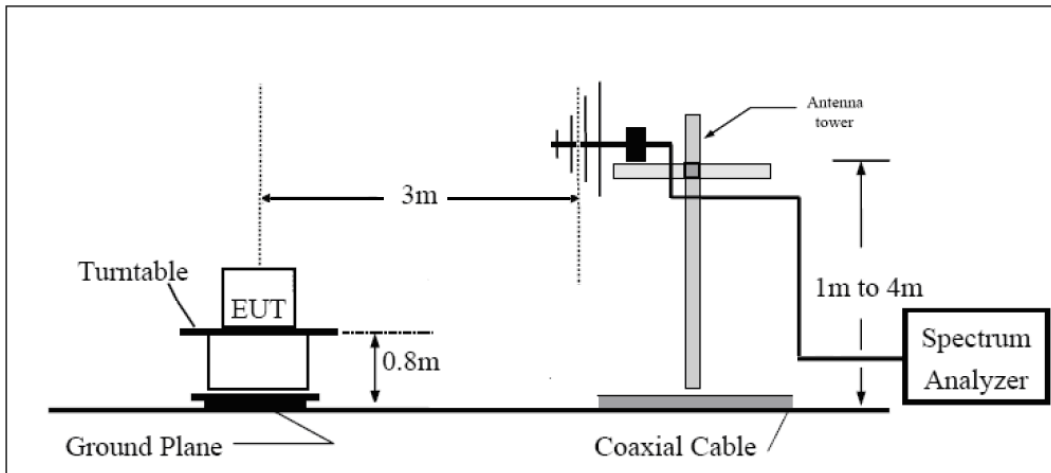

Above 1GHz

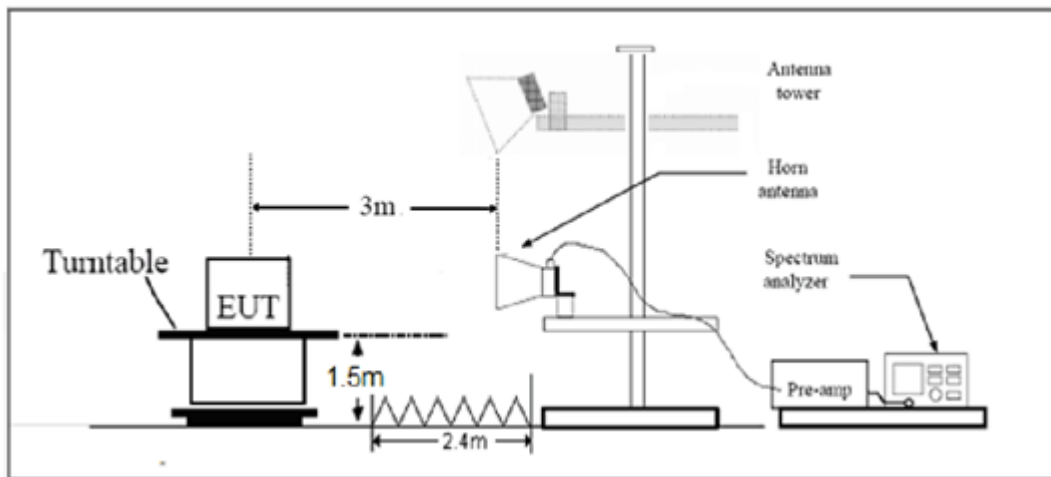

Note: Area side:2.4mX3.6m

The radiated emission was measured in the following position: EUT stand-up position (Z axis), lie-down position (X, Y axis). The worst emission was found in stand-up position (Z axis) and the worst case was recorded.

**Limits**

Rule Part 27.50(b) (10) specifies that “Portable stations (hand-held devices) transmitting in the 746-757 MHz, 776-788 MHz, and 805-806 MHz bands are limited to 3 watts ERP”

Rule Part 27.50(c) (10) specifies that “Portable stations (hand-held devices) in the 600 MHz uplink band and the 698-746 MHz band, and fixed and mobile stations in the 600 MHz uplink band are limited to 3 watts ERP”

Part 27.50(b)(10)Limit (ERP) -LTE 13	$\leq 3 \text{ W}$ (34.77 dBm)
Part 27.50(c)(10)Limit (ERP) -LTE 17	$\leq 3 \text{ W}$ (34.77 dBm)

Measurement Uncertainty

The assessed measurement uncertainty to ensure 95% confidence level for the normal distribution is with the coverage factor $k = 2$, $U = 1.19 \text{ dB}$

Test Results

LTE Band 13								
Bandwidth	Ant Pot (H/V)	Frequency (MHz)	Rt (dBm)	Rs (dBm)	Ps (dBm)	Gs (dBi)	ERP (dBm)	Conclusion
5MHz (QPSK)	H	779.5	-48.78	-47.01	0.00	1.81	15.93	Pass
	H	782	-48.93	-47.17	0.00	1.81	16.65	Pass
	H	784.5	-49.38	-47.59	0.00	1.83	16.64	Pass
	V	779.5	-48.47	-46.67	0.00	1.81	11.24	Pass
	V	782	-48.36	-46.56	0.00	1.81	10.54	Pass
	V	784.5	-48.67	-46.85	0.00	1.83	10.91	Pass
10MHz (QPSK)	H	782	-48.52	-46.75	0.00	1.81	16.73	Pass
	V	782	-48.38	-46.58	0.00	1.81	11.07	Pass
5MHz (16QAM)	H	779.5	-48.78	-47.01	0.00	1.81	15.70	Pass
	H	782	-48.93	-47.17	0.00	1.81	16.42	Pass
	H	784.5	-49.38	-47.59	0.00	1.83	16.41	Pass
	V	779.5	-48.47	-46.67	0.00	1.81	11.01	Pass
	V	782	-48.36	-46.56	0.00	1.81	10.31	Pass
	V	784.5	-48.67	-46.85	0.00	1.83	10.68	Pass
10MHz (16QAM)	H	782	-48.52	-46.75	0.00	1.81	16.60	Pass
	V	782	-48.38	-46.58	0.00	1.81	10.94	Pass

LTE Band 17								
Bandwidth	Ant Pot (H/V)	Frequency (MHz)	Rt (dBm)	Rs (dBm)	Ps (dBm)	Gs (dBi)	ERP (dBm)	Conclusion
5MHz (QPSK)	H	706.5	-49.27	-47.53	0.00	1.78	15.69	Pass
	H	710	-49.43	-47.69	0.00	1.78	15.61	Pass
	H	713.5	-49.87	-48.11	0.00	1.80	16.23	Pass
	V	706.5	-48.96	-47.20	0.00	1.78	10.26	Pass
	V	710	-48.85	-47.08	0.00	1.78	10.20	Pass
	V	713.5	-49.16	-47.38	0.00	1.80	10.93	Pass
10MHz (QPSK)	H	709	-49.27	-47.53	0.00	1.78	15.64	Pass
	H	710	-49.43	-47.69	0.00	1.78	15.64	Pass
	H	711	-49.87	-48.11	0.00	1.80	15.91	Pass
	V	709	-48.96	-47.20	0.00	1.78	10.34	Pass
	V	710	-48.85	-47.08	0.00	1.78	10.23	Pass
	V	711	-49.16	-47.38	0.00	1.80	10.39	Pass
5MHz (16QAM)	H	706.5	-49.27	-47.53	0.00	1.78	15.45	Pass
	H	710	-49.43	-47.69	0.00	1.78	15.37	Pass
	H	713.5	-49.87	-48.11	0.00	1.80	15.99	Pass
	V	706.5	-48.97	-47.20	0.00	1.78	10.02	Pass
	V	710	-48.85	-47.08	0.00	1.78	9.96	Pass
	V	713.5	-49.16	-47.38	0.00	1.80	10.69	Pass
10MHz (16QAM)	H	709	-49.27	-47.53	0.00	1.78	15.29	Pass
	H	710	-49.43	-47.69	0.00	1.78	15.29	Pass
	H	711	-49.88	-48.11	0.00	1.80	15.56	Pass
	V	709	-48.97	-47.20	0.00	1.78	9.99	Pass
	V	710	-48.85	-47.08	0.00	1.78	9.88	Pass
	V	711	-49.17	-47.38	0.00	1.80	10.04	Pass

Note: 1. EIRP= E.R.P+2.15

4.3 Occupied Bandwidth

Ambient condition

Temperature	Relative humidity	Pressure
23°C ~25°C	45%~50%	101.5kPa

Method of Measurement

The EUT was connected to Spectrum Analyzer and Base Station Simulator via power Splitter. The occupied bandwidth is measured using spectrum analyzer.

RBW is set to 100 kHz, VBW is set to 300 kHz for LTE Band 13/17 (5MHz).

RBW is set to 300 kHz, VBW is set to 1MHz for LTE Band 13/17 (10MHz).

99% power and -26dBc occupied bandwidths are recorded. Spectrum analyzer plots are included on the following pages.

Test Setup

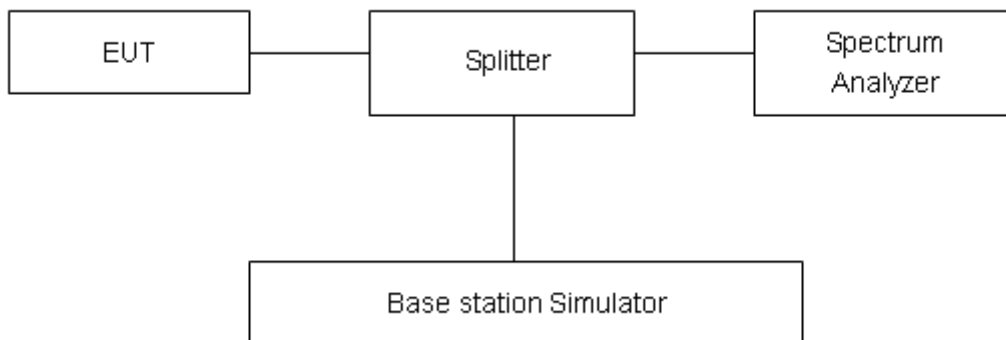

Limits

No specific occupied bandwidth requirements in part 2.1049.

Measurement Uncertainty

The assessed measurement uncertainty to ensure 95% confidence level for the normal distribution is with the coverage factor $k = 2$, $U=624\text{Hz}$.



Test Result

LTE Band 13						
RB	Modulation	Bandwidth (MHz)	Channel	Frequency (MHz)	99% Power Bandwidth(kHz)	-26dBc Bandwidth(kHz)
100%	QPSK	5	23205	779.5	4.5230	5.060
			23230	782	4.5383	5.090
			23255	784.5	4.5210	5.042
		10	23230	782	9.0689	10.210
	16QAM	5	23205	779.5	4.5400	5.093
			23230	782	4.5258	5.090
			23255	784.5	4.5471	5.112
		10	23230	782	9.0742	10.110

LTE Band 17						
RB	Modulation	Bandwidth (MHz)	Channel	Frequency (MHz)	99% Power Bandwidth(kHz)	-26dBc Bandwidth(kHz)
100%	QPSK	5	23755	706.5	4.5397	5.077
			23790	710	4.5258	5.095
			23825	713.5	4.5235	5.081
		10	23780	709	9.0715	10.230
			23790	710	9.0399	10.110
			23800	711	9.0722	10.160
	16QAM	5	23755	706.5	4.5266	5.066
			23790	710	4.5461	5.070
			23825	713.5	4.5474	5.104
		10	23780	709	9.0478	10.100
			23790	710	9.0508	10.150
			23800	711	9.0549	10.130



LTE Band 13 QPSK 5MHz CH-Low



LTE Band 13 QPSK 5MHz CH-Middle



LTE Band 13 QPSK 5MHz CH-High

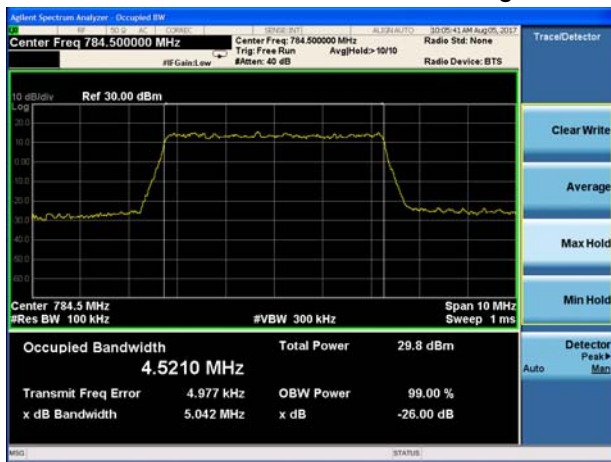

LTE Band 13 QPSK 10MHz CH-Middle

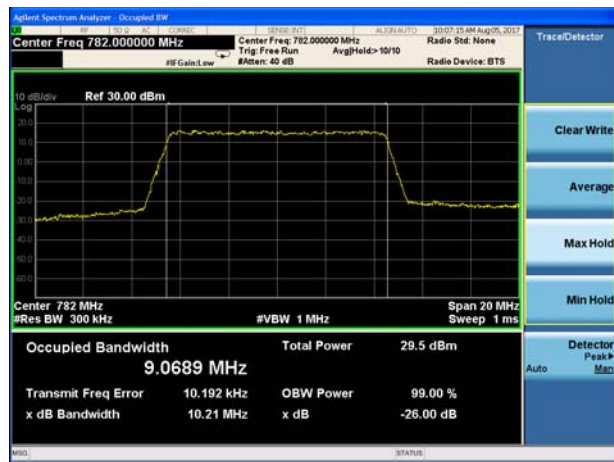

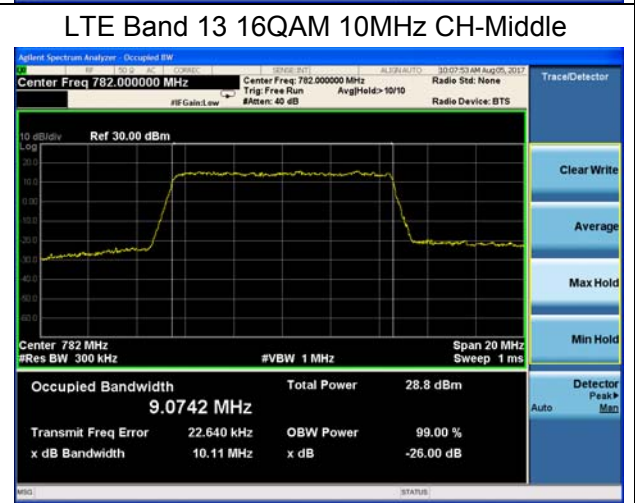
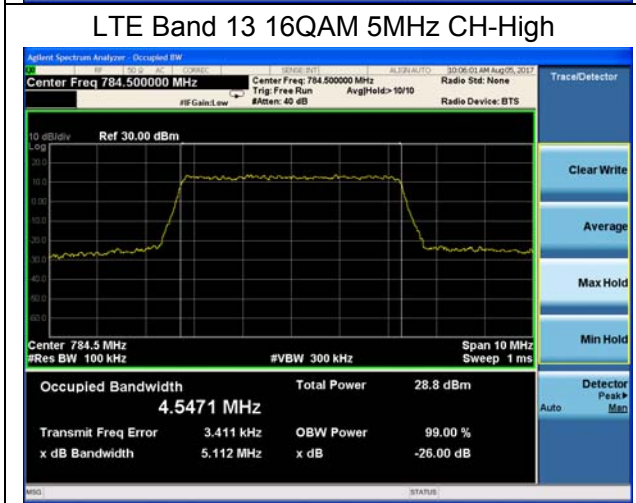
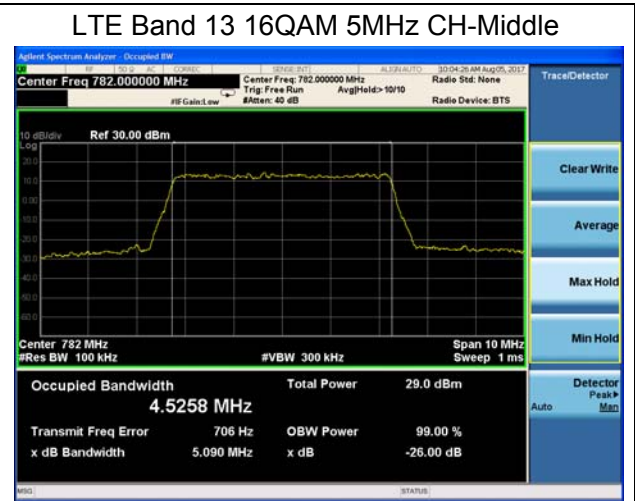
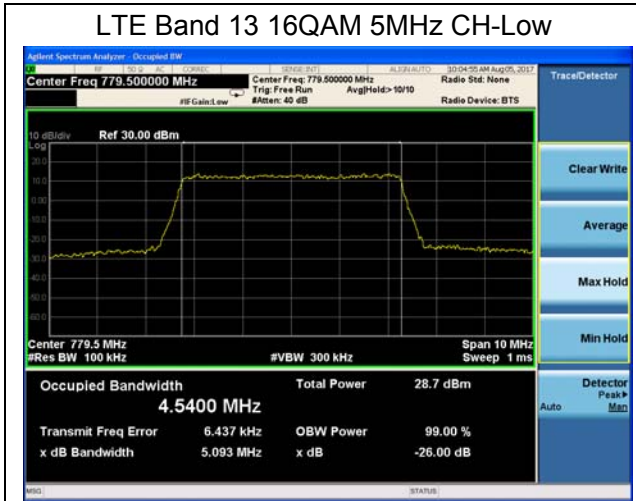



LTE Band 17 QPSK 5MHz CH-Low



LTE Band 17 QPSK 10MHz CH-Low



LTE Band 17 QPSK 5MHz CH-Middle

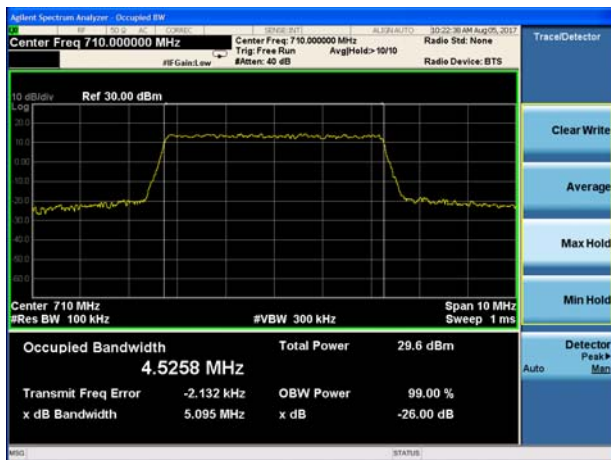

LTE Band 17 QPSK 10MHz CH-Middle



LTE Band 17 QPSK 5MHz CH-High

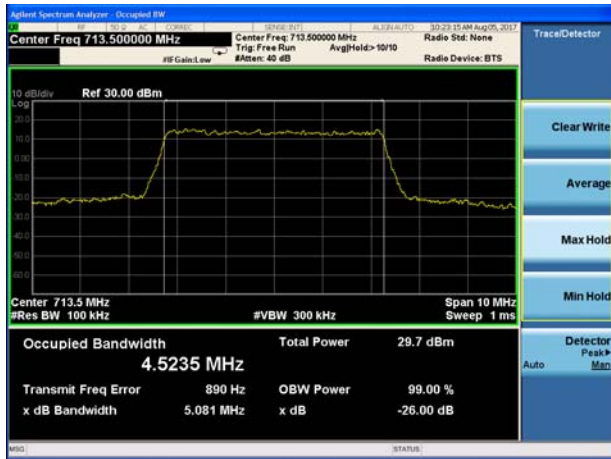

LTE Band 17 QPSK 10MHz CH-High



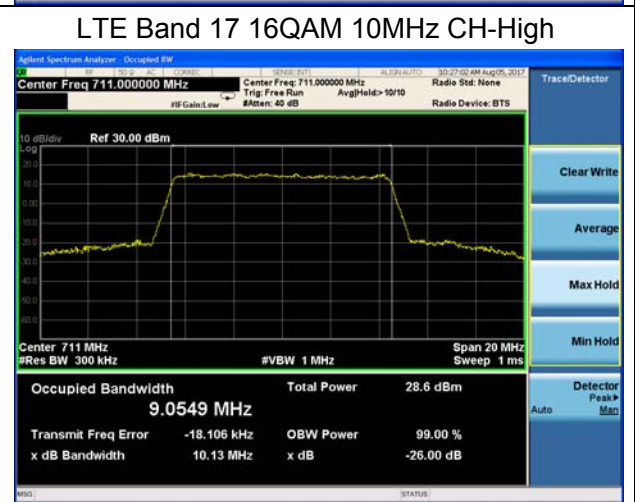
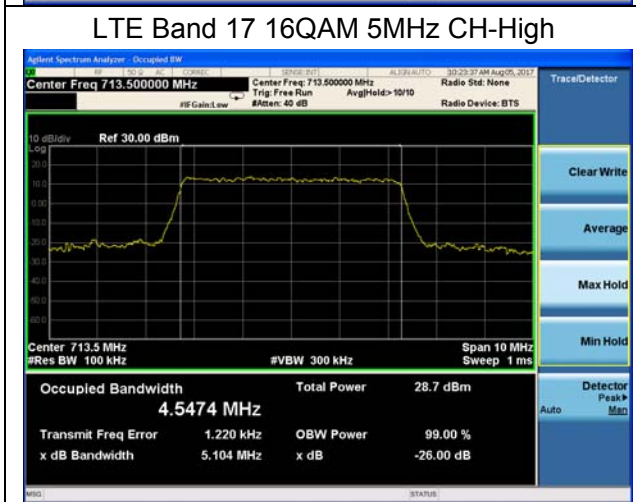
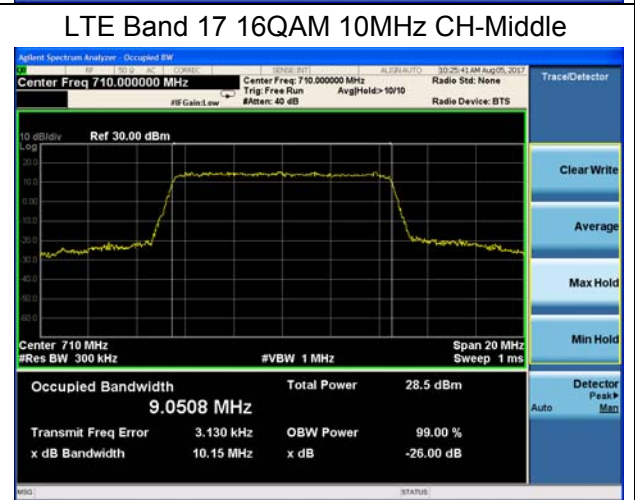
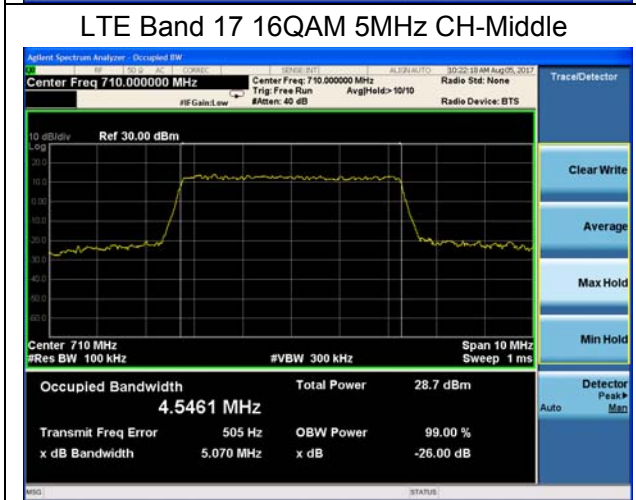
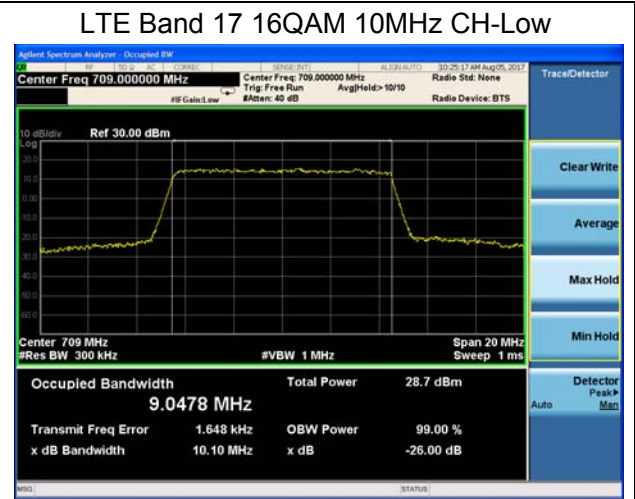
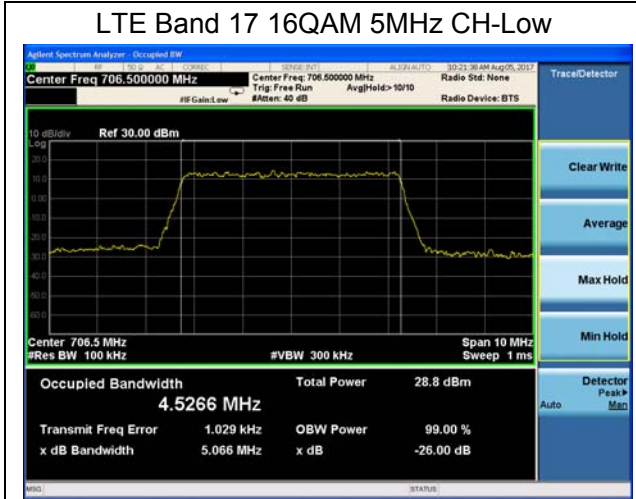

4.4 Band Edge Compliance

Ambient condition

Temperature	Relative humidity	Pressure
23°C ~25°C	45%~50%	101.5kPa

Method of Measurement

The EUT was connected to Spectrum Analyzer and Base Station Simulator via power Splitter. The band edge of the lowest and highest channels were measured.

The testing follows KDB 971168 v02r02 Section 6.0

- 1.The EUT was connected to spectrum analyzer and system simulator via a power divider.
2. The band edges of low and high channels for the highest RF powers were measured.
3. RBW is set to 51 kHz, VBW is set to 160 kHz for LTE Band 13/17 (5MHz).
RBW is set to 100 kHz, VBW is set to 300kHz for LTE Band 13/17 (10MHz).
4. Set spectrum analyzer with RMS detector.
5. The RF fundamental frequency should be excluded against the limit line in the operating frequency band.
6. Checked that all the results comply with the emission limit line.

Test Setup

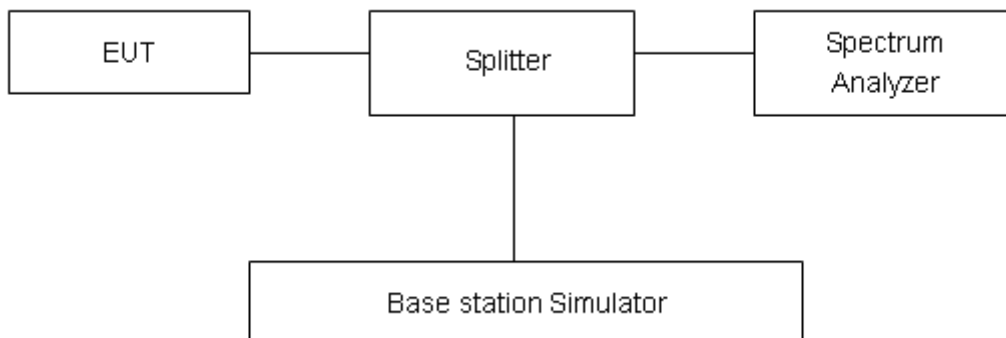



Limits

Part 27.53(g) specifies that “ For operations in the 600 MHz band and the 698-746 MHz band, the power of any emission outside a licensee's frequency block shall be attenuated below the transmitter power (P) within the licensed band(s) of operation, measured in watts, by at least $43 + 10 \log_{10} (P)$ dB.”

Measurement Uncertainty

The assessed measurement uncertainty to ensure 95% confidence level for the normal distribution is with the coverage factor $k = 1.96$, $U=0.684\text{dB}$.

Test Result

All the test traces in the plots shows the test results clearly.

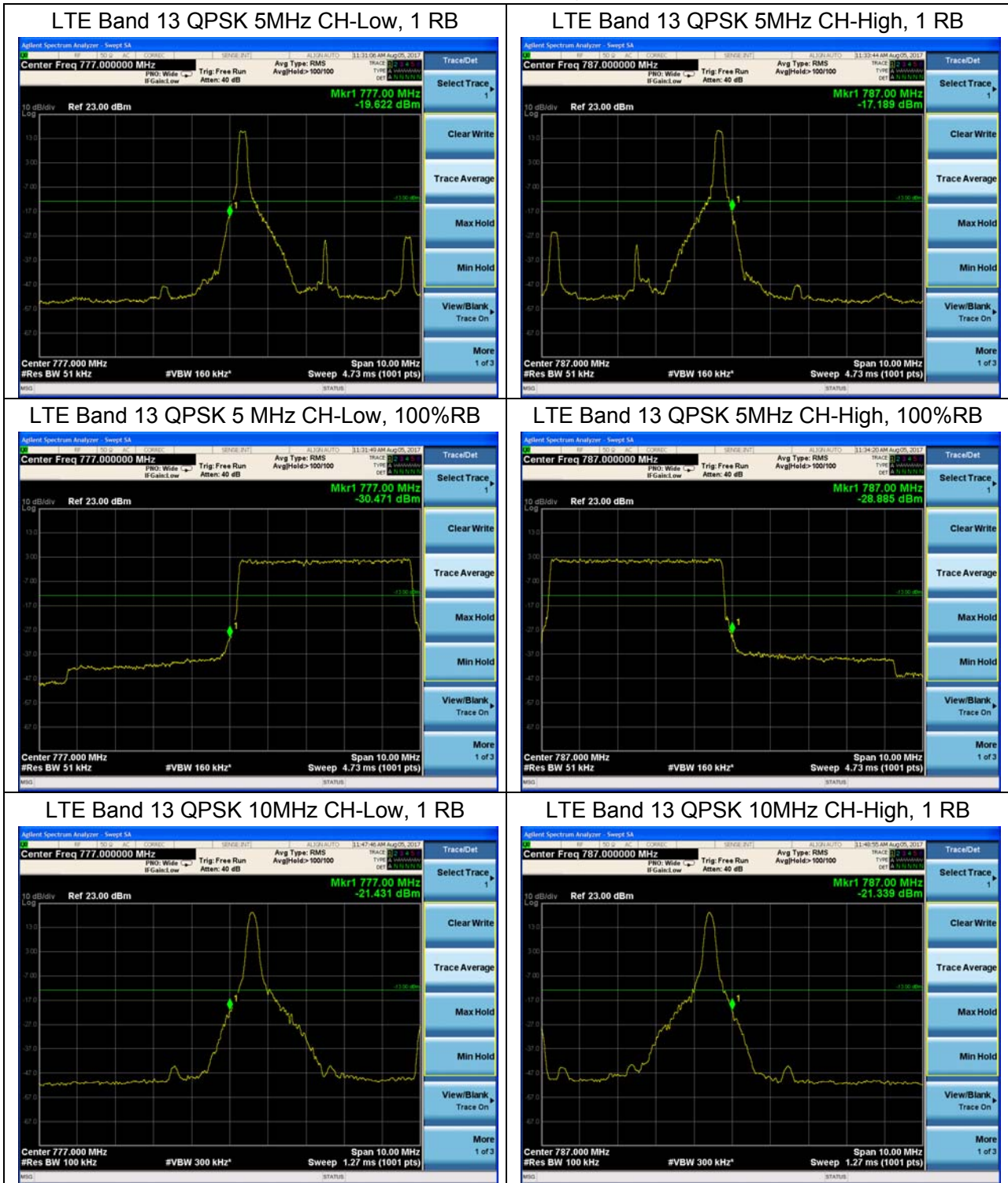

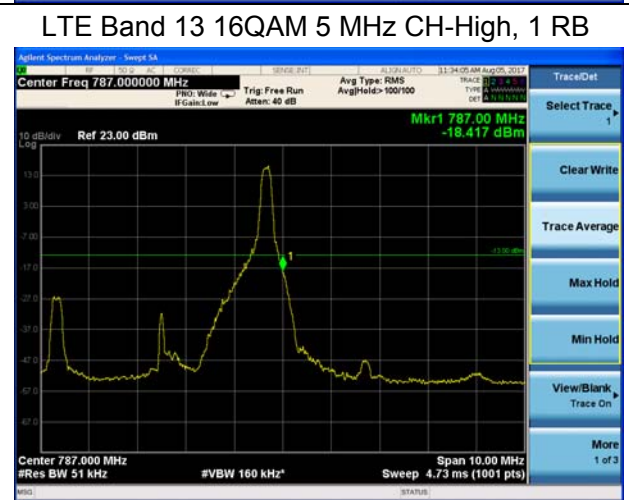
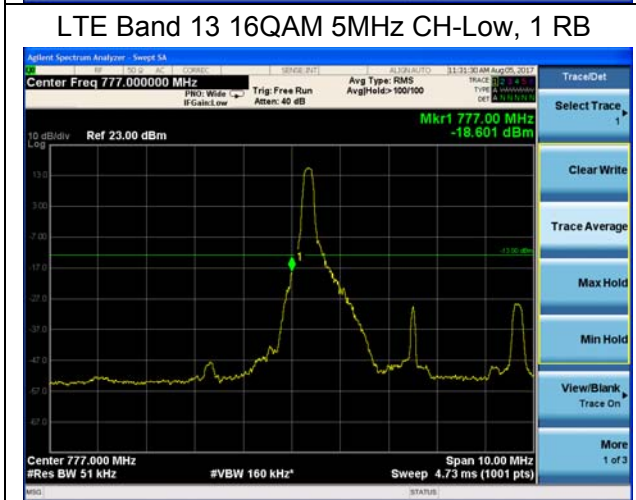
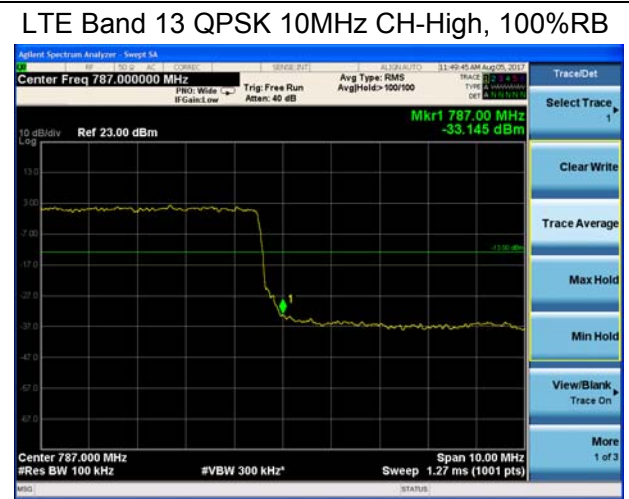
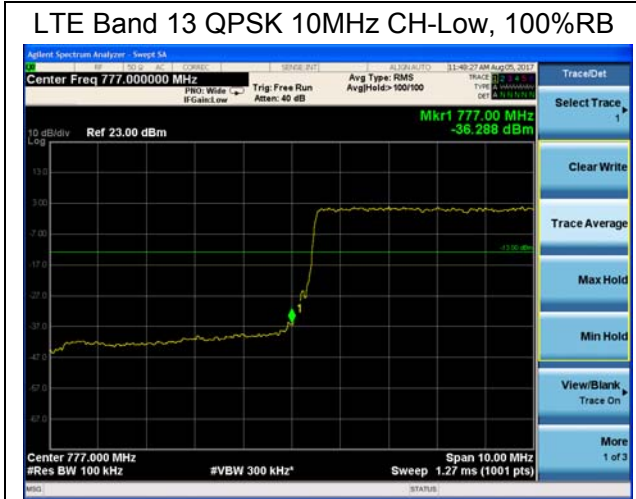

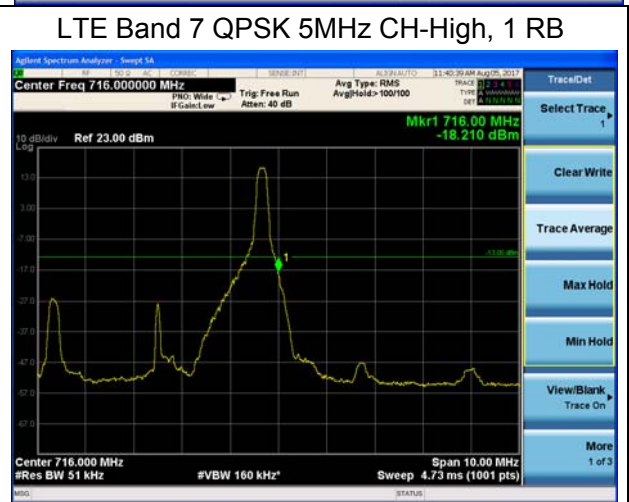
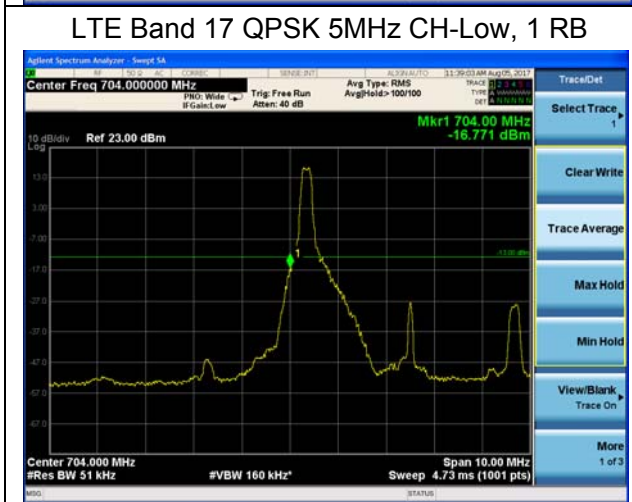
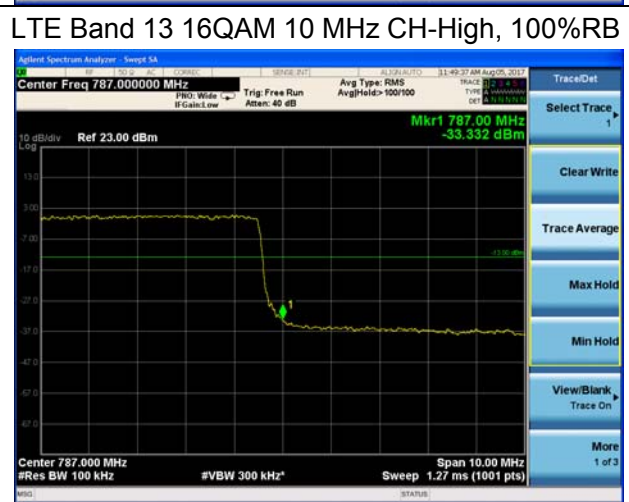
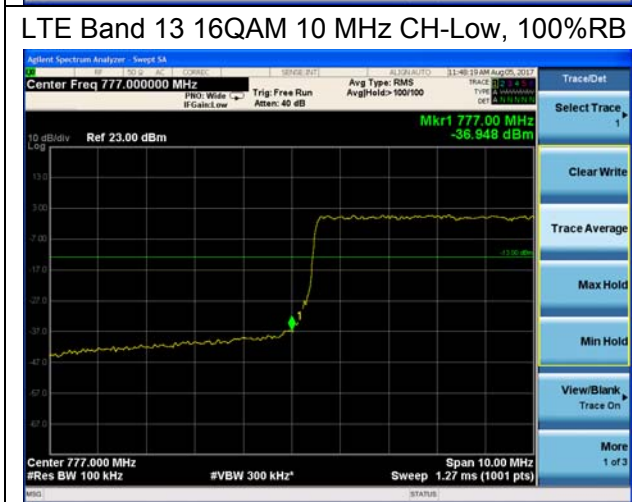
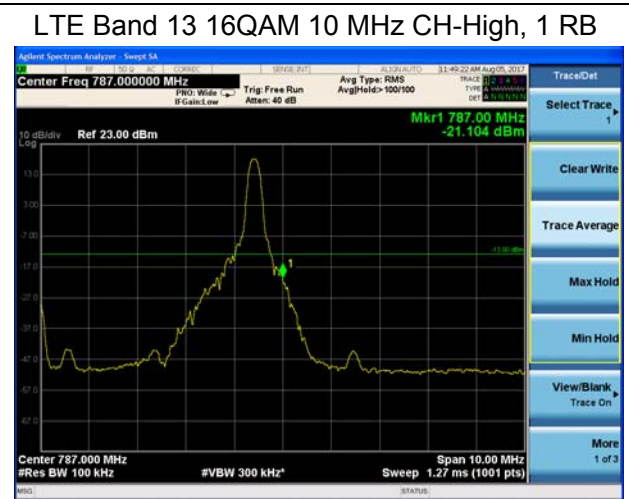
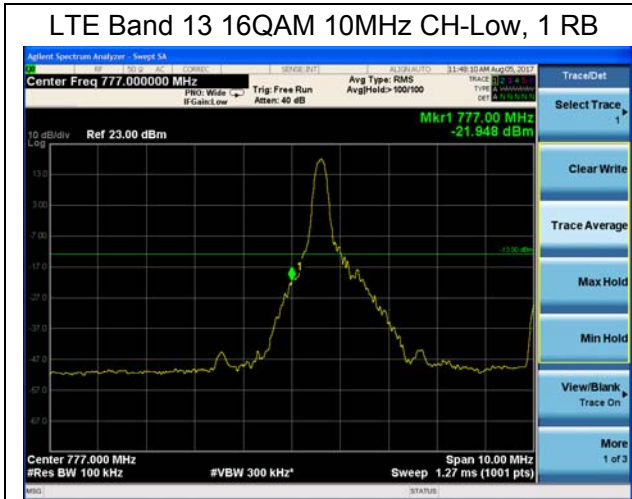



LTE Band 17 QPSK 5MHz CH-Low, 100%RB

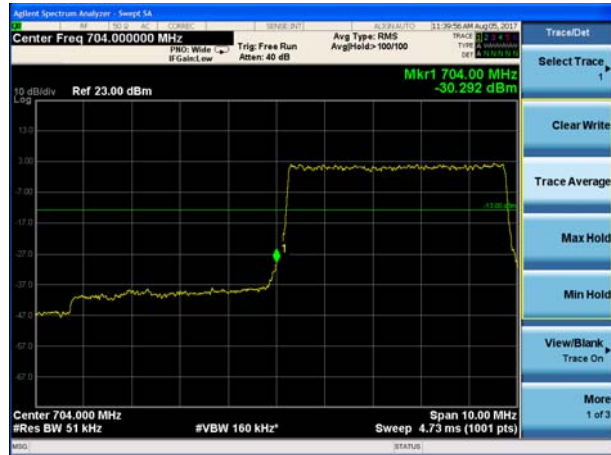

LTE Band 17 QPSK 5MHz CH-High, 100%RB



LTE Band 17 QPSK 10MHz CH-Low, 1 RB

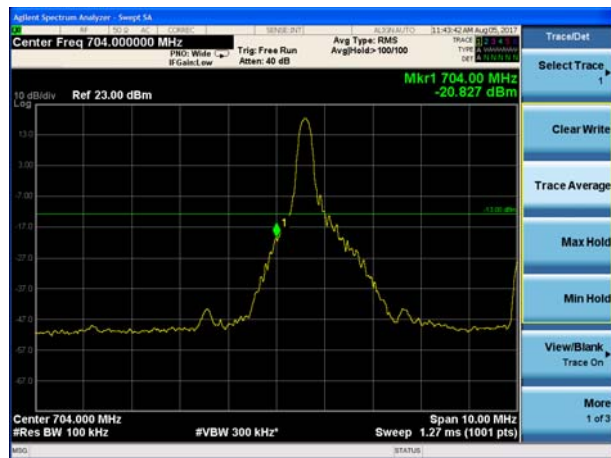

LTE Band 17 QPSK 10MHz CH-High, 1 RB

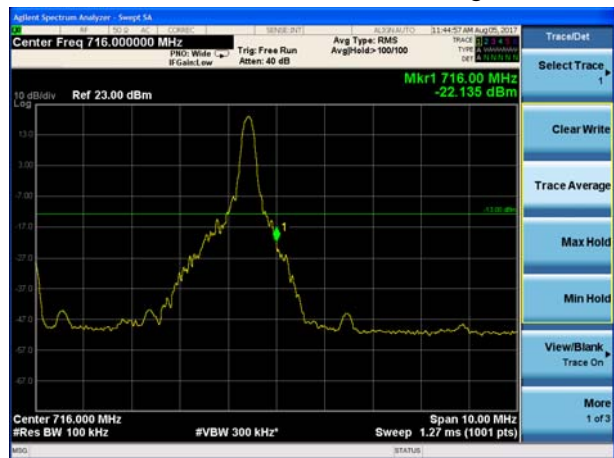

LTE Band 17 QPSK 10MHz CH-Low, 100%RB



LTE Band 17 QPSK 10MHz CH-High, 100%RB





LTE Band 17 16QAM 5MHz CH-Low, 1 RB

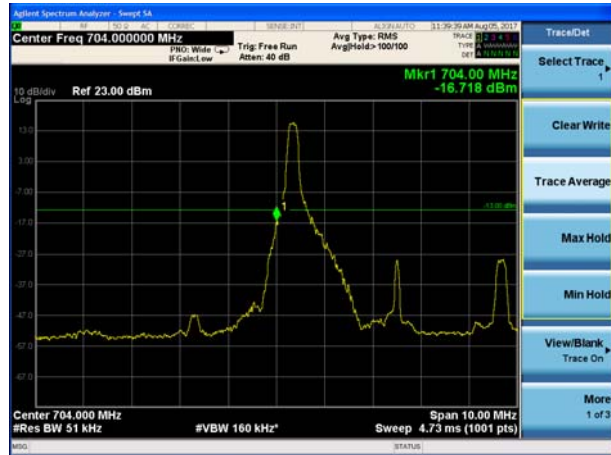

LTE Band 17 16QAM 5MHz CH-High, 1 RB

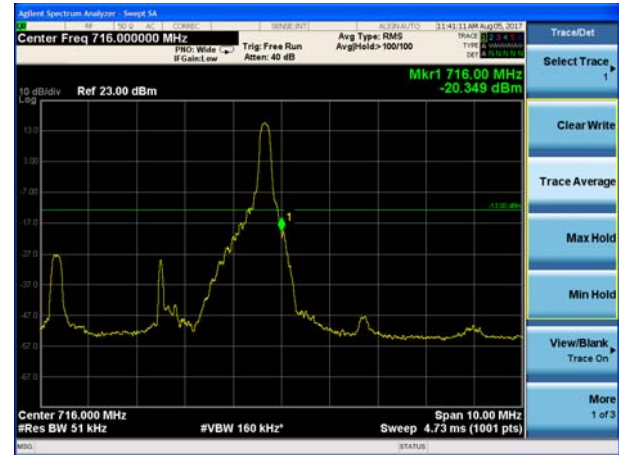

LTE Band 17 16QAM 5MHz CH-Low, 100%RB



LTE Band 17 16QAM 5MHz CH-High, 100%RB



LTE Band 17 16QAM 10MHz CH-Low, 1 RB

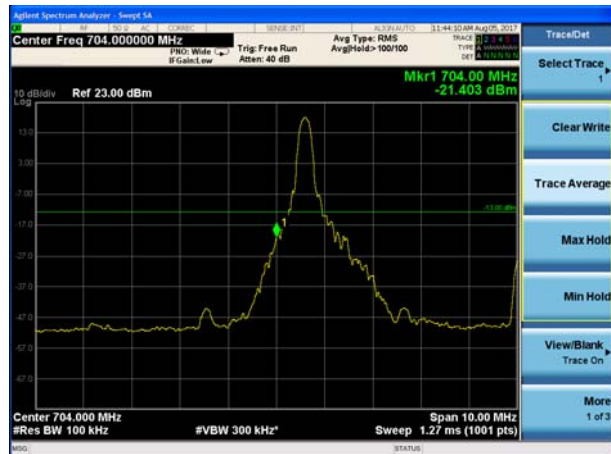

LTE Band 17 16QAM 10MHz CH-High, 1 RB

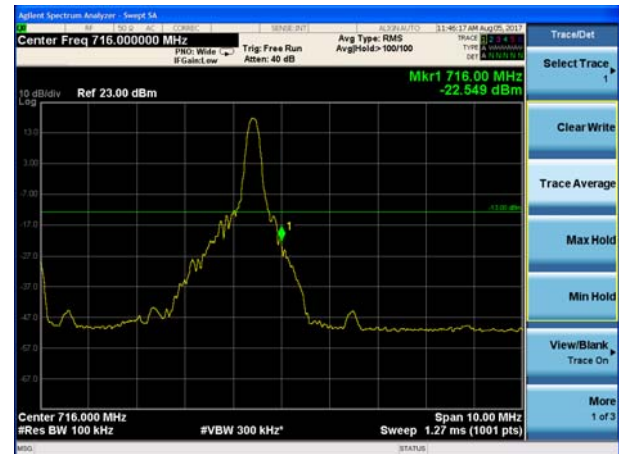



LTE Band 17 16QAM 10MHz CH-Low, 100%RB



LTE Band 17 16QAM 10MHz CH-High, 100%RB



4.5 Peak-to-Average Power Ratio (PAPR)

Ambient condition

Temperature	Relative humidity	Pressure
23°C ~25°C	45%~50%	101.5kPa

Methods of Measurement

Measure the total peak power and record as PPK. And measure the total average power and record as PAvg. Both the peak and average power levels must be expressed in the same logarithmic units (e.g., dBm). Determine the PAPR from:

$$PAPR (dB) = PPK (dBm) - PAvg (dBm).$$

Test Setup

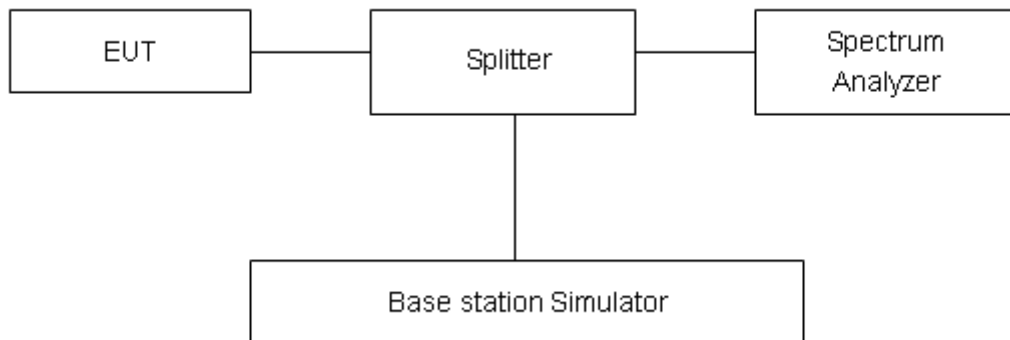

Limits

Rule Part 27.50(d)(5) Equipment employed must be authorized in accordance with the provisions of 24.51. Power measurements for transmissions by stations authorized under this section may be made either in accordance with a Commission-approved average power technique or in compliance with paragraph (d)(6) of this section. In measuring transmissions in this band using an average power technique, the peak-to-average ratio (PAR) of the transmission may not exceed 13 dB.

Measurement Uncertainty

The assessed measurement uncertainty to ensure 95% confidence level for the normal distribution is with the coverage factor k = 2, U= 0.4 dB.

Test Results

LTE Band 13								
Modulation	Bandwidth (MHz)	Channel	Frequency (MHz)	Peak (dBm)	Avg (dBm)	PAPR (dB)	Limit (dB)	Conclusion
QPSK	5	23205	779.5	25.30	20.20	5.10	≤13	PASS
		23230	782	26.23	20.18	6.05	≤13	PASS
		23255	784.5	26.30	20.17	6.13	≤13	PASS
	10	23230	782	26.26	20.28	5.98	≤13	PASS
16QAM	5	23205	779.5	25.45	19.18	6.27	≤13	PASS
		23230	782	25.95	19.26	6.69	≤13	PASS
		23255	784.5	25.85	19.15	6.70	≤13	PASS
	10	23230	782	25.90	19.27	6.63	≤13	PASS

LTE Band 17								
Modulation	Bandwidth (MHz)	Channel	Frequency (MHz)	Peak (dBm)	Avg (dBm)	PAPR (dB)	Limit (dB)	Conclusion
QPSK	5M	23755	706.5	26.58	20.72	5.86	≤13	PASS
		23790	710	26.12	20.84	5.28	≤13	PASS
		23852	713.5	26.10	20.86	5.24	≤13	PASS
	10M	23780	709	26.25	20.75	5.50	≤13	PASS
		23790	710	26.22	20.77	5.45	≤13	PASS
		23800	711	26.20	20.81	5.39	≤13	PASS
16QAM	5M	23755	706.5	26.65	20.10	6.55	≤13	PASS
		23790	710	26.17	20.19	5.98	≤13	PASS
		23852	713.5	25.94	20.07	5.87	≤13	PASS
	10M	23780	709	26.32	20.08	6.24	≤13	PASS
		23790	710	26.31	20.15	6.16	≤13	PASS
		23800	711	26.16	20.04	6.12	≤13	PASS

4.6 Frequency Stability

Ambient condition

Temperature	Relative humidity	Pressure
23°C ~25°C	45%~50%	101.5kPa

Method of Measurement

1. Frequency Stability (Temperature Variation)

The temperature inside the climate chamber is varied from -30°C to +50°C in 10°C step size.

(1)With all power removed, the temperature was decreased to -10°C and permitted to stabilize for three hours.

(2)Measure the carrier frequency with the test equipment in a “call mode”. These measurements should be made within 1 minute of powering up the mobile station, to prevent significant self warming.

(3) Repeat the above measurements at 10°C increments from -30°C to +50°C. Allow at least 1.5 hours at each temperature, un-powered, before making measurements.

2. Frequency Stability (Voltage Variation)

The frequency stability shall be measured with variation of primary supply voltage as follows:

(1) Vary primary supply voltage from 85 to 115 percent of the nominal value for other than hand carried battery equipment.

(2) For hand carried, battery powered equipment, reduce primary supply voltage to the battery-operating end point which shall be specified by the manufacturer.

This transceiver is specified to operate with an input voltage of between 3.4 V and 4.35 V, with a nominal voltage of 3.8V.

Test setup

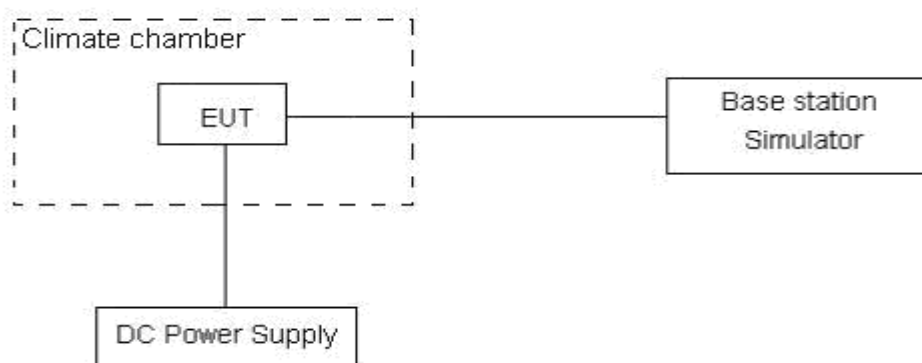

Limits

No specific frequency stability requirements in part 27.54

Measurement Uncertainty

The assessed measurement uncertainty to ensure 99.75% confidence level for the normal distribution is with the coverage factor $k = 3, U=0.01\text{ppm}$.

Test Result

Bandwidth	Test status	LTE Band 13 Channel 23230 Test Results (ppm)	
		QPSK	16QAM
5MHz	-30°C/Normal Voltage	0.00068	0.00445
	-20°C/Normal Voltage	-0.00205	-0.00251
	-10°C/Normal Voltage	0.00004	0.00001
	0°C/Normal Voltage	0.00145	0.00201
	10°C/Normal Voltage	-0.00040	-0.00102
	20°C/Normal Voltage	0.00170	-0.00123
	30°C/Normal Voltage	-0.00303	0.00226
	40°C/Normal Voltage	-0.00013	-0.00024
	50°C/Normal Voltage	-0.00271	0.00065
	20°C/Min Voltage	0.00203	0.00014
	20°C/Max Voltage	-0.00132	0.00111
10MHz	-30°C/Normal Voltage	0.00306	-0.00020
	-20°C/Normal Voltage	-0.00137	0.00226
	-10°C/Normal Voltage	-0.00097	-0.00425
	0°C/Normal Voltage	-0.00008	-0.00105
	10°C/Normal Voltage	0.00101	0.00339
	20°C/Normal Voltage	-0.00148	-0.00056
	30°C/Normal Voltage	-0.00226	0.00093
	40°C/Normal Voltage	-0.00645	-0.00403
	50°C/Normal Voltage	-0.00407	0.00262
	20°C/Min Voltage	0.00191	-0.00081
	20°C/Max Voltage	-0.00079	-0.00042

Bandwidth	Test status	LTE Band 17 Channel 23790 Test Results (ppm)	
		QPSK	16QAM
5MHz	-30°C/Normal Voltage	0.00027	-0.00290
	-20°C/Normal Voltage	-0.00158	-0.00469
	-10°C/Normal Voltage	-0.00407	-0.00392
	0°C/Normal Voltage	-0.00145	-0.00327
	10°C/Normal Voltage	-0.00318	0.00207
	20°C/Normal Voltage	-0.00010	-0.00123
	30°C/Normal Voltage	-0.00331	-0.00262
	40°C/Normal Voltage	-0.00448	-0.00239
	50°C/Normal Voltage	-0.00627	-0.00434
	20°C/Min Voltage	-0.00046	-0.00004
	20°C/Max Voltage	-0.00072	-0.00338
10MHz	-30°C/Normal Voltage	0.00070	-0.00130
	-20°C/Normal Voltage	-0.00254	-0.00046
	-10°C/Normal Voltage	-0.00479	-0.00403
	0°C/Normal Voltage	-0.00268	-0.00234
	10°C/Normal Voltage	0.00115	0.00123
	20°C/Normal Voltage	-0.00146	0.00175
	30°C/Normal Voltage	0.00248	-0.00006
	40°C/Normal Voltage	0.00108	0.00155
	50°C/Normal Voltage	0.00154	-0.00248
	20°C/Min Voltage	0.00087	-0.00275
	20°C/Max Voltage	-0.00407	0.00041

4.7 Spurious Emissions at Antenna Terminals

Ambient condition

Temperature	Relative humidity	Pressure
23°C ~25°C	45%~50%	101.5kPa

Method of Measurement

The EUT was connected to Spectrum Analyzer and Base Station Simulator via power Splitter. The measurement is carried out using a spectrum analyzer. The spectrum analyzer scans from 30MHz to the 10th harmonic of the carrier. The peak detector is used. Set RBW 1MHz and VBW 3MHz, Sweep is set to ATUO.

Of those disturbances below (limit – 20 dB), the mark is not required for the EUT.

Test setup

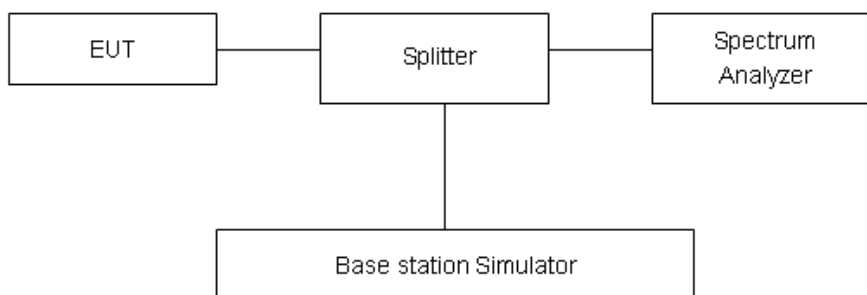

Limits

Rule Part 27.53 (g) For operations in the 600 MHz band and the 698-746 MHz band, the power of any emission outside a licensee's frequency band(s) of operation shall be attenuated below the transmitter power (P) within the licensed band(s) of operation, measured in watts, by at least 43 + 10 log (P) dB. Compliance with this provision is based on the use of measurement instrumentation employing a resolution bandwidth of 100 kilohertz or greater. However, in the 100 kilohertz bands immediately outside and adjacent to a licensee's frequency block, a resolution bandwidth of at least 30 kHz may be employed.

Rule Part 27.53(f) For operations in the 746-758 MHz, 775-788 MHz, and 805-806 MHz bands, emissions in the band 1559-1610 MHz shall be limited to –70 dBW/MHz equivalent isotropically radiated power (EIRP) for wideband signals, and –80 dBW EIRP for discrete emissions of less than 700 Hz bandwidth. For the purpose of equipment authorization, a transmitter shall be tested with an antenna that is representative of the type that will be used with the equipment in normal operation.



LTE B13/17 Limit

Limit out of the band 1559-1610 MHz	-13 dBm
Limit in the band 1559-1610 MHz	-40 dBm

The assessed measurement uncertainty to ensure 99.75% confidence level for the normal distribution is with the coverage factor $k = 1.96$.

Frequency	Uncertainty
100kHz-2GHz	0.684 dB
2GHz-12.75GHz	1.407 dB

Test Result: PASS

If disturbances were found more than 20dB below limit line, the mark is not required for the EUT.
The signal beyond the limit is carrier in the following plots.

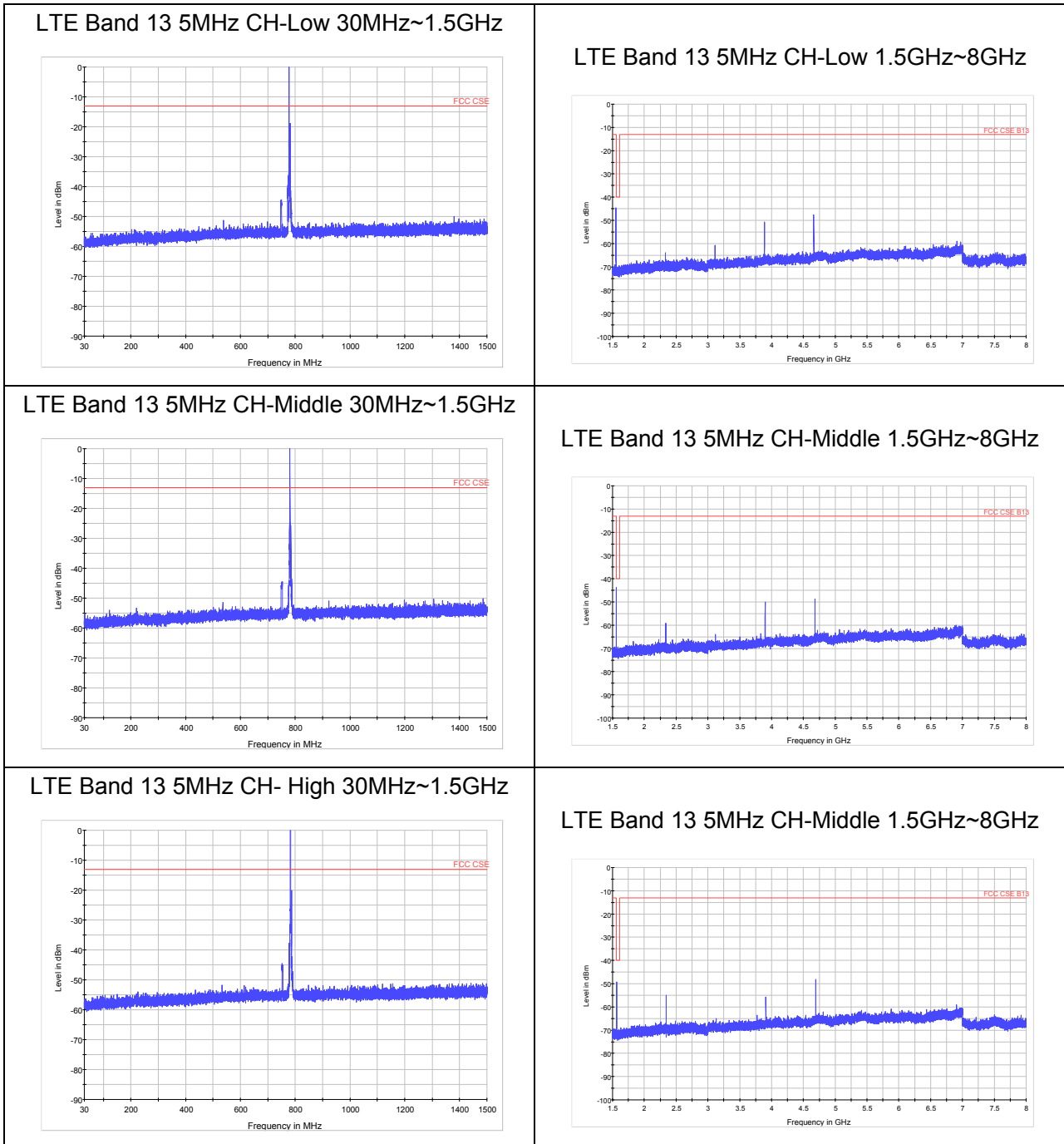



LTE Band 13 10MHz CH-Low 30MHz~1.5GHz

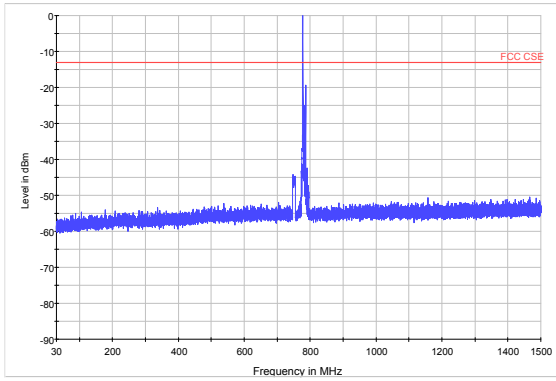

LTE Band 13 10MHz CH-Low 1.5GHz~8GHz

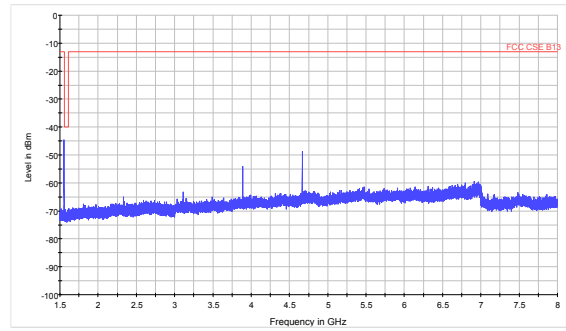

LTE Band 13 10MHz CH-Middle 30MHz~1.5GHz

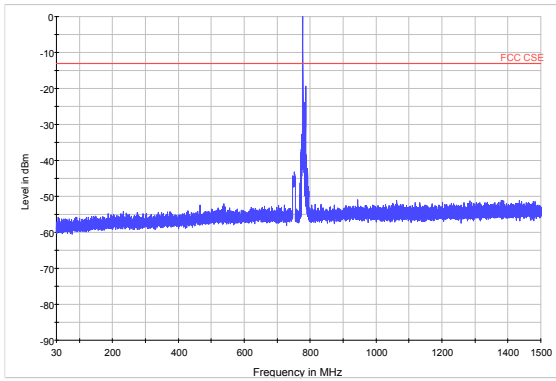

LTE Band 13 10MHz CH-Middle 1.5GHz~8GHz

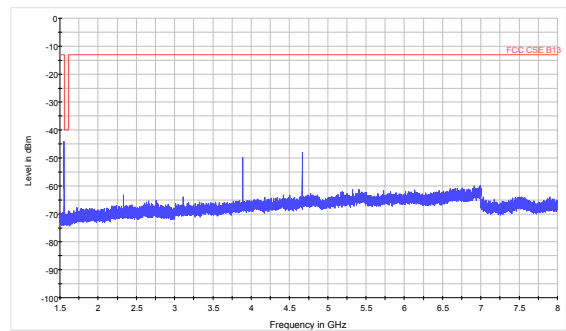

LTE Band 13 10MHz CH- High 30MHz~1.5GHz

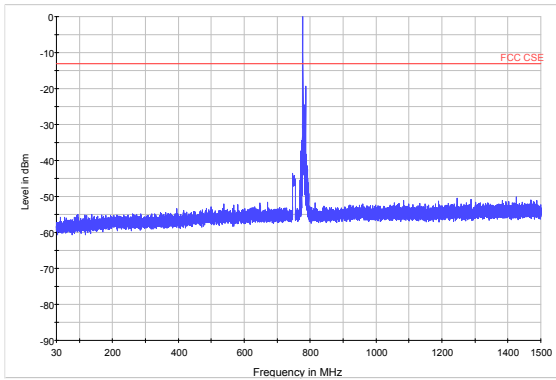

LTE Band 13 10MHz CH-Middle 1.5GHz~8GHz

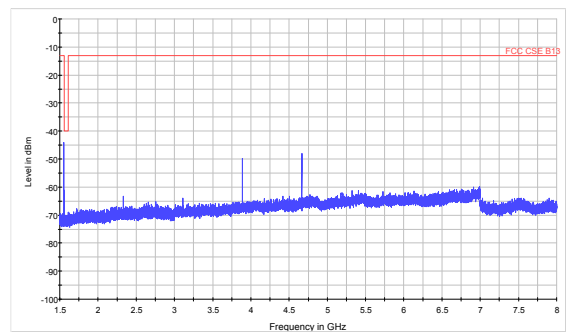



LTE Band 17MHz CH-Low 30MHz~1GHz

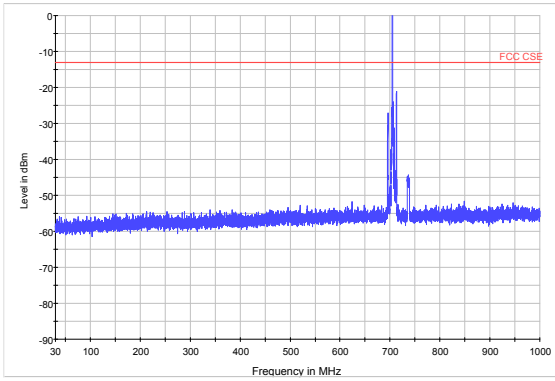

LTE Band 17 5MHz CH-Middle 30MHz~1GHz

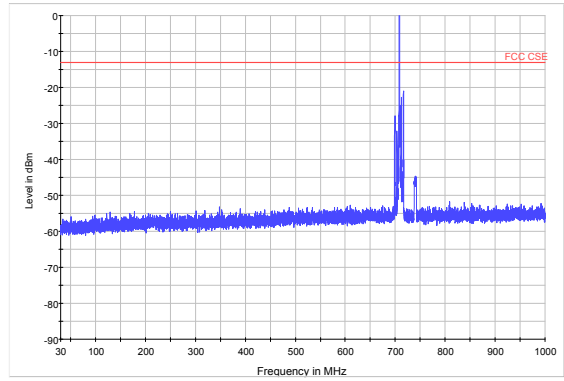

LTE Band 17 5MHz CH Low 1GHz~3GHz

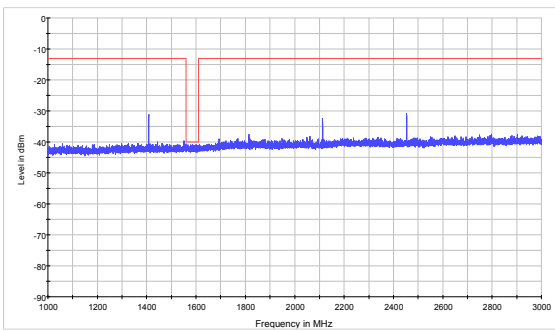

LTE Band 17 5MHz CH-Middle 1GHz~3GHz

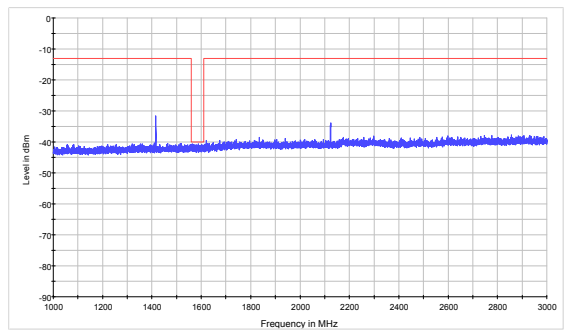

LTE Band 17 5MHz CH-Low 3GHz~8GHz

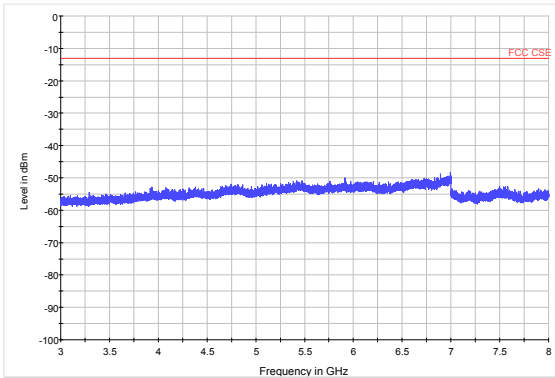

LTE Band 17 5MHz CH-Middle 3GHz~8GHz

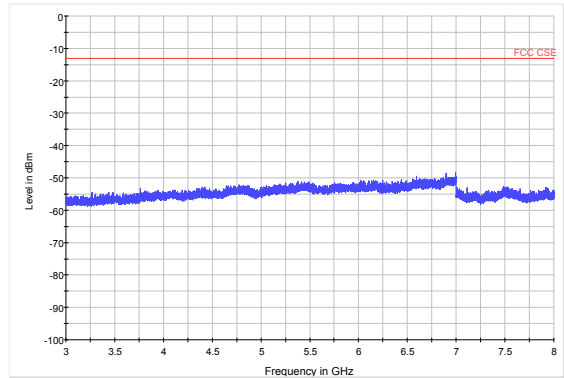



LTE Band17 5MHz CH- High 30MHz~1GHz

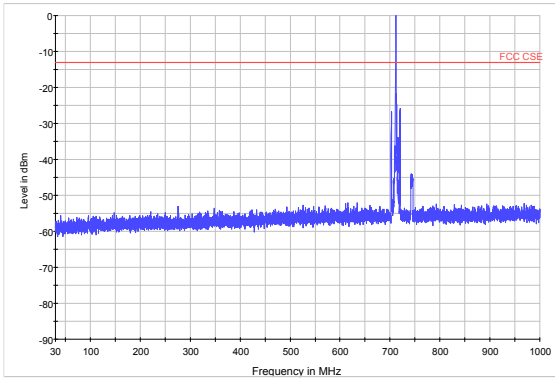

LTE Band 17 10MHz CH-Low 30MHz~1GHz

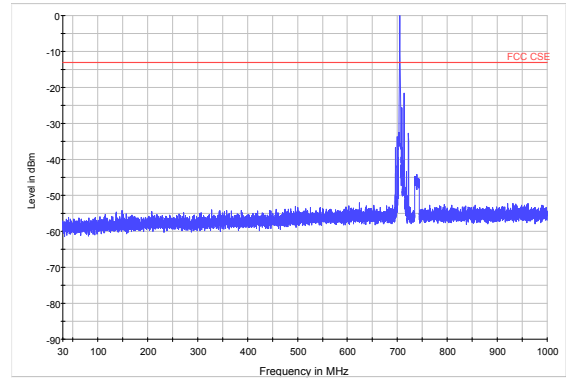

LTE Band 17 5MHz CH- High 1GHz~3GHz

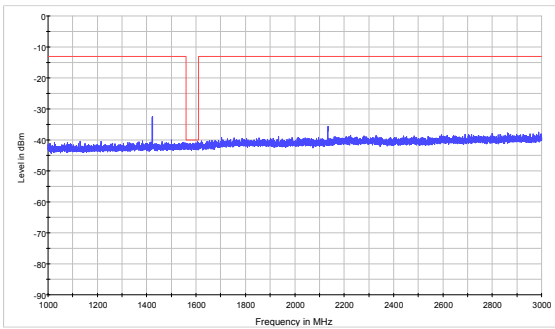

LTE Band 17 10MHz CH-Low 1GHz~3GHz

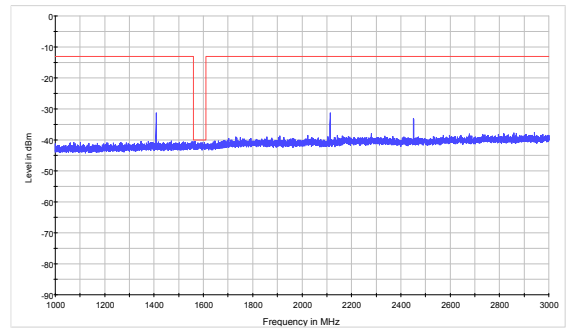

LTE Band17 5MHz CH- High 3GHz~8GHz

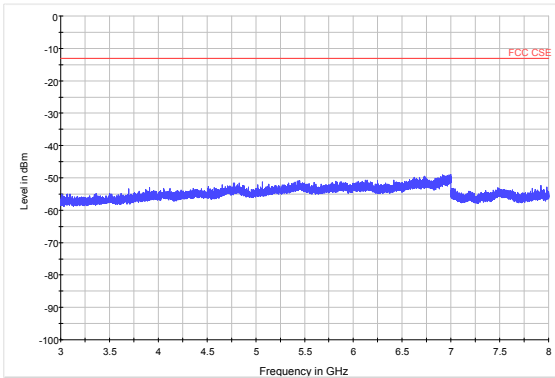

LTE Band 17 10MHz CH-Low 3GHz~8GHz

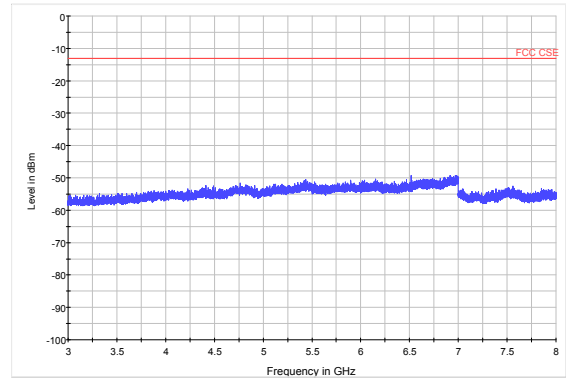



LTE Band 17 10MHz CH-Middle 30MHz~1GHz

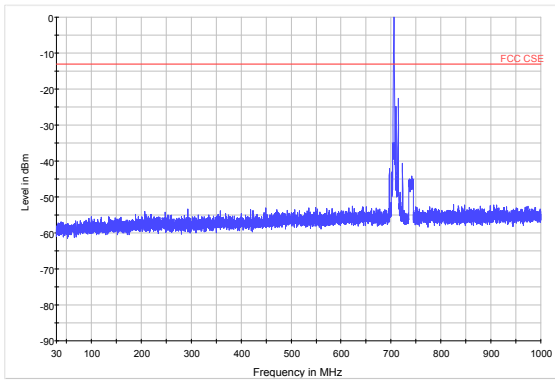

LTE Band 17 10MHz CH-High 30MHz~1GHz

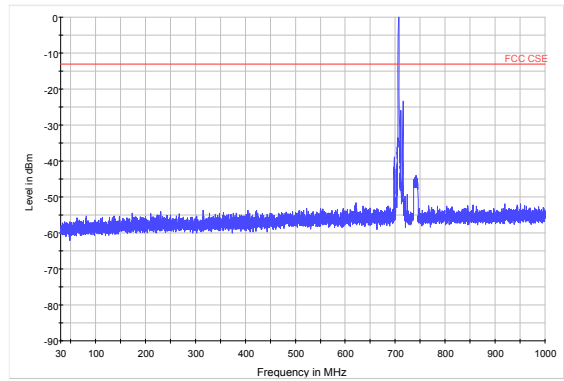

LTE Band 17 10MHz CH-Middle 1GHz~3GHz

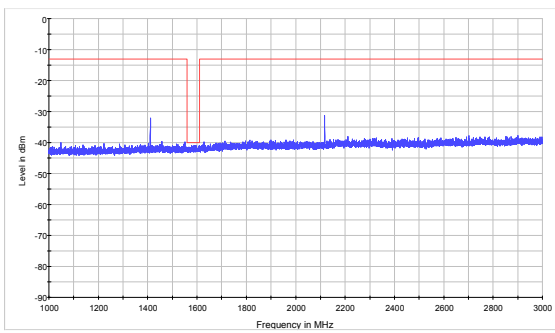

LTE Band 17 10MHz CH-High 1GHz~3GHz

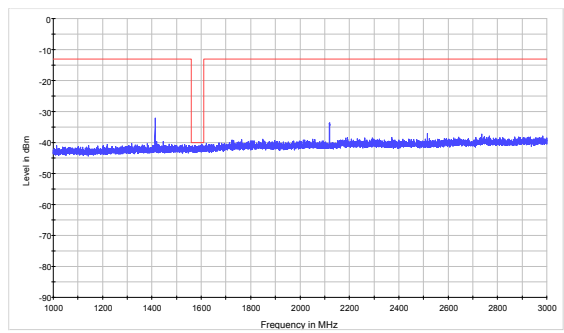

LTE Band 17 10MHz CH-Middle 3GHz~8GHz

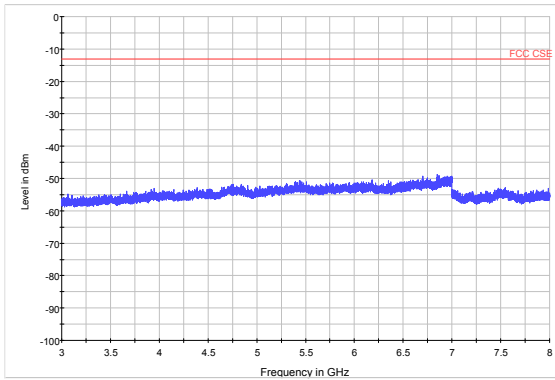

LTE Band 17 10MHz CH-High 3GHz~8GHz

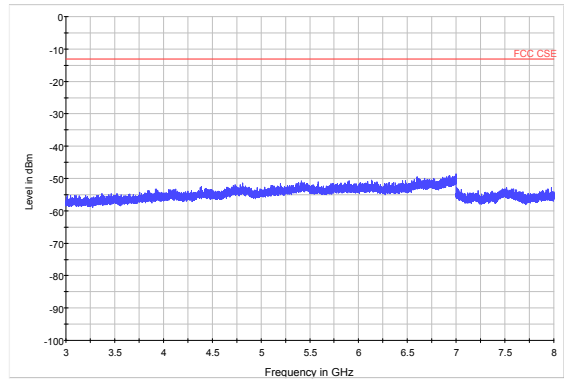

4.8 Radiates Spurious Emission

Ambient condition

Temperature	Relative humidity	Pressure
23°C ~25°C	45%~50%	101.5kPa

Method of Measurement

- The testing follows ANSI C63.26 (2015) Section 5.5.2.3.
- Above 30MHz: The EUT is placed on a turntable 0.8 meters above the ground in the chamber, 3 meter away from the antenna. The maximal emission value is acquired by adjusting the antenna height, polarisation and turntable azimuth. Normally, the height range of antenna is 1 m to 4 m, the azimuth range of turntable is 0° to 360°, and the receive antenna has two polarizations Vertical (V) and Horizontal (H). Above 1GHz: (Note: the FCC's permission to use 1.5m as an alternative per TCBC Conf call of Dec. 2, 2014.) The EUT is placed on a turntable 1.5 meters above the ground in the chamber, 3 meter away from the antenna. The maximal emission value is acquired by adjusting the antenna height, polarisation and turntable azimuth. Normally, the height range of antenna is 1 m to 4 m, the azimuth range of turntable is 0° to 360°, and the receive antenna has two polarizations Vertical (V) and Horizontal (H).
- A log-periodic antenna or double-ridged waveguide horn antenna shall be substituted in place of the EUT. The log-periodic antenna will be driven by a signal generator and the level will be adjusted till the same power value on the spectrum analyzer or receiver. The level of the spurious emissions can be calculated through the level of the signal generator, cable loss, the gain of the substitution antenna and the reading of the spectrum analyzer or receiver.
- The EUT is then put into continuously transmitting mode at its maximum power level during the test. Set Test Receiver or Spectrum RBW=1MHz, VBW=3MHz, And the maximum value of the receiver should be recorded as (Pr).
- The EUT shall be replaced by a substitution antenna. In the chamber, an substitution antenna for the frequency band of interest is placed at the reference point of the chamber. An RF Signal source for the frequency band of interest is connected to the substitution antenna with a cable that has been constructed to not interfere with the radiation pattern of the antenna. A power (PMea) is applied to the input of the substitution antenna, and adjust the level of the signal generator output until the value of the receiver reach the previously recorded (Pr). The power of signal source (PMea) is recorded. The test should be performed by rotating the test item and adjusting the receiving antenna polarization.
- A amplifier should be connected to the Signal Source output port. And the cable should be connect between the Amplifier and the Substitution Antenna. The cable loss (Pcl) ,the Substitution Antenna Gain (Ga) and the Amplifier Gain (PAg) should be recorded after test.
- The measurement results are obtained as described below:

$$\text{Power(EIRP)} = \text{PMea} - \text{PAg} - \text{Pcl} + \text{Ga}$$
The measurement results are amend as described below:

$$\text{Power(EIRP)} = \text{PMea} - \text{Pcl} + \text{Ga}$$
- This value is EIRP since the measurement is calibrated using an antenna of known gain (2.15 dBi) and known input power. ERP can be calculated from EIRP by subtracting the gain of the dipole, $\text{ERP} = \text{EIRP} - 2.15\text{dBi}$.

Test setup

30MHz~~~ 1GHz

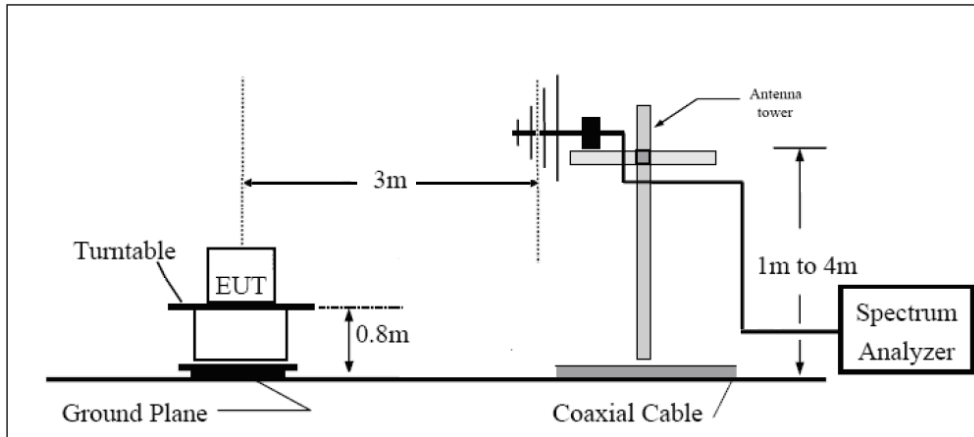

Above 1GHz

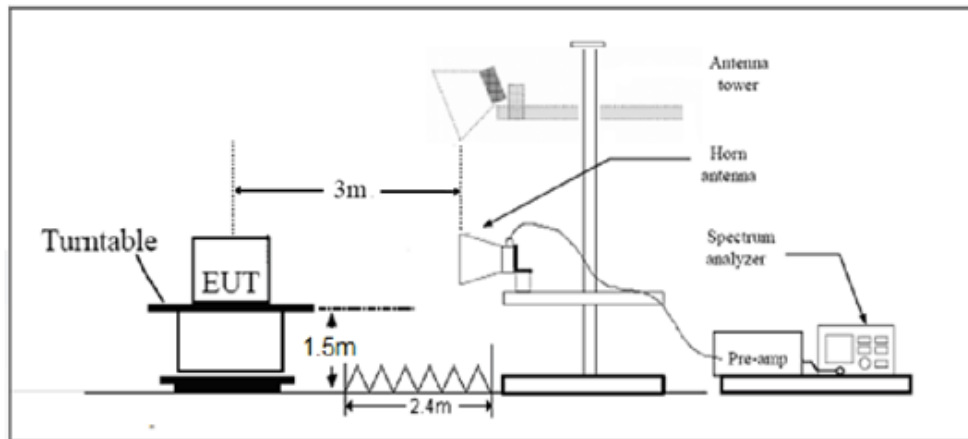

Note: Area side:2.4mX3.6m

The radiated emission was measured in the following position: EUT stand-up position (Z axis), lie-down position (X, Y axis). The worst emission was found in stand-up position (Z axis) and the worst case was recorded.

Limits

Rule Part 27.53(f) For operations in the 746-758 MHz, 775-788 MHz, and 805-806 MHz bands, emissions in the band 1559-1610 MHz shall be limited to -70 dBW/MHz equivalent isotropically radiated power (EIRP) for wideband signals, and -80 dBW EIRP for discrete emissions of less than 700 Hz bandwidth. For the purpose of equipment authorization, a transmitter shall be tested with an antenna that is representative of the type that will be used with the equipment in normal operation.

LTE B13/17 Limit	Limit out of the band 1559-1610 MHz	-13 dBm
	Limit in the band 1559-1610 MHz	-40 dBm

Measurement Uncertainty

The assessed measurement uncertainty to ensure 95% confidence level for the normal distribution is with the coverage factor $k = \pm 1.96$, $U = \pm 3.55$ dB.

Test Result

LTE Band 13 QPSK 5MHz CH-Low, RB 1

Harmonic	Frequency (MHz)	SG (dBm)	Cable Loss (dB)	Gain (dBi)	Antenna Polarization	ERP Level (dBm)	Limit (dBm)	Margin (dB)	Azimuth (deg)
2	1554.75	-45.30	2.00	10.15	Vertical	-39.3	-13.0	26.3	45
3	2332.3125	-56.70	2.50	11.35	Vertical	-50.0	-13.0	37.0	225
4	3118	-62.10	4.20	10.85	Vertical	-57.6	-13.0	44.6	45
5	3897.5	-55.90	5.20	11.35	Vertical	-51.9	-13.0	38.9	45
6	4664.25	-55.90	5.50	11.95	Vertical	-51.6	-13.0	38.6	225
7	5456.5	-58.30	5.70	13.55	Vertical	-52.6	-13.0	39.6	45
8	6236	-56.90	6.30	13.75	Vertical	-51.6	-13.0	38.6	225
9	7015.5	-56.00	6.80	13.85	Vertical	-51.1	-13.0	38.1	270
10	7795	-56.50	6.90	14.25	Vertical	-51.3	-13.0	38.3	225

Note: 1.The other Spurious RF Radiated emissions level is no more than noise floor.

2. The worst emission was found in the antenna is vertical position.

LTE Band 13 QPSK 5MHz CH-Middle, RB 1

Harmonic	Frequency (MHz)	SG (dBm)	Cable Loss (dB)	Gain (dBi)	Antenna Polarization	ERP Level (dBm)	Limit (dBm)	Margin (dB)	Azimuth (deg)
2	1559.25	-57.10	2.00	10.75	Vertical	-50.5	-40.0	10.5	225
3	2346	-56.69	2.51	11.05	Vertical	-50.3	-13.0	37.3	45
4	3128	-62.40	4.20	11.15	Vertical	-57.6	-13.0	44.6	225
5	3910	-55.70	5.20	11.15	Vertical	-51.9	-13.0	38.9	270
6	4678.875	-56.40	5.50	11.95	Vertical	-52.1	-13.0	39.1	90
7	5474	-58.30	5.70	13.55	Vertical	-52.6	-13.0	39.6	45
8	6256	-56.90	6.30	13.75	Vertical	-51.6	-13.0	38.6	225
9	7038	-56.00	6.80	13.85	Vertical	-51.1	-13.0	38.1	45
10	7820	-56.50	6.90	14.25	Vertical	-51.3	-13.0	38.3	225

Note: 1.The other Spurious RF Radiated emissions level is no more than noise floor.

2. The worst emission was found in the antenna is vertical position.

LTE Band 13 QPSK 5MHz CH-High, RB 1

Harmonic	Frequency (MHz)	SG (dBm)	Cable Loss (dB)	Gain (dBi)	Antenna Polarization	ERP Level (dBm)	Limit (dBm)	Margin (dB)	Azimuth (deg)
2	1564.5	-54.00	2.00	10.15	Vertical	-48.0	-40.0	8.0	270
3	2353.5	-50.09	2.51	11.05	Vertical	-43.7	-13.0	30.7	90
4	3138	-62.40	4.20	11.15	Vertical	-57.6	-13.0	44.6	45
5	3922.5	-55.70	5.20	11.15	Vertical	-51.9	-13.0	38.9	225
6	4707	-58.50	5.50	11.95	Vertical	-54.2	-13.0	41.2	45
7	5491.5	-58.30	5.70	13.55	Vertical	-52.6	-13.0	39.6	225
8	6276	-56.90	6.30	13.75	Vertical	-51.6	-13.0	38.6	270
9	7060.5	-56.00	6.80	13.85	Vertical	-51.1	-13.0	38.1	225
10	7845	-56.50	6.90	14.25	Vertical	-51.3	-13.0	38.3	45

Note: 1.The other Spurious RF Radiated emissions level is no more than noise floor.

2. The worst emission was found in the antenna is vertical position.

LTE Band 13 QPSK 10MHz CH-Low, RB 1

Harmonic	Frequency (MHz)	SG (dBm)	Cable Loss (dB)	Gain (dBi)	Antenna Polarization	ERP Level (dBm)	Limit (dBm)	Margin (dB)	Azimuth (deg)
2	1551.25	-38.60	2.00	10.15	Vertical	-32.6	-13.0	19.6	225
3	2346	-56.89	2.51	11.35	Vertical	-50.2	-13.0	37.2	45
4	3128	-62.10	4.20	10.85	Vertical	-57.6	-13.0	44.6	225
5	3910	-55.90	5.20	11.35	Vertical	-51.9	-13.0	38.9	270
6	4692	-58.50	5.50	11.95	Vertical	-54.2	-13.0	41.2	225
7	5474	-58.30	5.70	13.55	Vertical	-52.6	-13.0	39.6	45
8	6256	-56.90	6.30	13.75	Vertical	-51.6	-13.0	38.6	225
9	7038	-56.00	6.80	13.85	Vertical	-51.1	-13.0	38.1	270
10	7820	-56.50	6.90	14.25	Vertical	-51.3	-13.0	38.3	90

Note: 1.The other Spurious RF Radiated emissions level is no more than noise floor.

2. The worst emission was found in the antenna is vertical position.

LTE Band 13 QPSK 10MHz CH-Middle, RB 1

Harmonic	Frequency (MHz)	SG (dBm)	Cable Loss (dB)	Gain (dBi)	Antenna Polarization	ERP Level (dBm)	Limit (dBm)	Margin (dB)	Azimuth (deg)
2	1555.1	-40.40	2.00	10.75	Vertical	-33.8	-13.0	20.8	90
3	2346	-56.49	2.51	11.05	Vertical	-50.1	-13.0	37.1	45
4	3128	-62.40	4.20	11.15	Vertical	-57.6	-13.0	44.6	225
5	3910	-55.70	5.20	11.15	Vertical	-51.9	-13.0	38.9	45
6	4665.75	-55.70	5.50	11.95	Vertical	-51.4	-13.0	38.4	225
7	5474	-58.30	5.70	13.55	Vertical	-52.6	-13.0	39.6	45
8	6256	-56.90	6.30	13.75	Vertical	-51.6	-13.0	38.6	45
9	7038	-56.00	6.80	13.85	Vertical	-51.1	-13.0	38.1	225
10	7820	-56.50	6.90	14.25	Vertical	-51.3	-13.0	38.3	45

Note: 1.The other Spurious RF Radiated emissions level is no more than noise floor.

2. The worst emission was found in the antenna is vertical position.

LTE Band 13 QPSK 10MHz CH-High, RB 1

Harmonic	Frequency (MHz)	SG (dBm)	Cable Loss (dB)	Gain (dBi)	Antenna Polarization	ERP Level (dBm)	Limit (dBm)	Margin (dB)	Azimuth (deg)
2	1555.1	-39.20	2.00	10.15	Vertical	-33.2	-13.0	20.2	45
3	2346	-57.79	2.51	11.05	Vertical	-51.4	-13.0	38.4	225
4	3128	-62.40	4.20	11.15	Vertical	-57.6	-13.0	44.6	270
5	3910	-55.70	5.20	11.15	Vertical	-51.9	-13.0	38.9	225
6	4665.75	-55.60	5.50	11.95	Vertical	-51.3	-13.0	38.3	45
7	5474	-58.30	5.70	13.55	Vertical	-52.6	-13.0	39.6	225
8	6256	-56.90	6.30	13.75	Vertical	-51.6	-13.0	38.6	270
9	7038	-56.00	6.80	13.85	Vertical	-51.1	-13.0	38.1	90
10	7820	-56.50	6.90	14.25	Vertical	-51.3	-13.0	38.3	45

Note: 1.The other Spurious RF Radiated emissions level is no more than noise floor.

2. The worst emission was found in the antenna is vertical position.

LTE Band 17 QPSK 5MHz CH-Low, RB 1

Harmonic	Frequency (MHz)	SG (dBm)	Cable Loss (dB)	Gain (dBi)	Antenna Polarization	ERP Level (dBm)	Limit (dBm)	Margin (dB)	Azimuth (deg)
2	1413	-64.00	2.00	10.15	Vertical	-58.0	-13.0	45.0	45
3	2119.5	-64.80	2.50	11.35	Vertical	-58.1	-13.0	45.1	225
4	2826	-60.10	4.20	10.85	Vertical	-55.6	-13.0	42.6	45
5	3532.5	-62.00	5.20	11.35	Vertical	-58.0	-13.0	45.0	90
6	4239	-59.40	5.50	11.95	Vertical	-55.1	-13.0	42.1	45
7	4945.5	-59.40	5.70	13.55	Vertical	-53.7	-13.0	40.7	225
8	5652	-57.50	6.30	13.75	Vertical	-52.2	-13.0	39.2	45
9	6358.5	-56.00	6.80	13.85	Vertical	-51.1	-13.0	38.1	225
10	7065	-56.40	6.90	14.25	Vertical	-51.2	-13.0	38.2	45

Note: 1.The other Spurious RF Radiated emissions level is no more than noise floor.

2. The worst emission was found in the antenna is vertical position.

LTE Band 17 QPSK 5MHz CH-Middle, RB 1

Harmonic	Frequency (MHz)	SG (dBm)	Cable Loss (dB)	Gain (dBi)	Antenna Polarization	ERP Level (dBm)	Limit (dBm)	Margin (dB)	Azimuth (deg)
2	1420	-64.60	2.00	10.75	Vertical	-58.0	-13.0	45.0	45
3	2130	-64.49	2.51	11.05	Vertical	-58.1	-13.0	45.1	225
4	2840	-60.40	4.20	11.15	Vertical	-55.6	-13.0	42.6	270
5	3550	-61.80	5.20	11.15	Vertical	-58.0	-13.0	45.0	225
6	4260	-59.40	5.50	11.95	Vertical	-55.1	-13.0	42.1	270
7	4970	-59.40	5.70	13.55	Vertical	-53.7	-13.0	40.7	225
8	5680	-57.50	6.30	13.75	Vertical	-52.2	-13.0	39.2	45
9	6390	-56.00	6.80	13.85	Vertical	-51.1	-13.0	38.1	225
10	7100	-56.40	6.90	14.25	Vertical	-51.2	-13.0	38.2	270

Note: 1.The other Spurious RF Radiated emissions level is no more than noise floor.

2. The worst emission was found in the antenna is vertical position.

LTE Band 17 QPSK 5MHz CH-High, RB 1

Harmonic	Frequency (MHz)	SG (dBm)	Cable Loss (dB)	Gain (dBi)	Antenna Polarization	ERP Level (dBm)	Limit (dBm)	Margin (dB)	Azimuth (deg)
2	1427	-64.00	2.00	10.15	Vertical	-58.0	-13.0	45.0	225
3	2140.5	-64.49	2.51	11.05	Vertical	-58.1	-13.0	45.1	270
4	2854	-60.40	4.20	11.15	Vertical	-55.6	-13.0	42.6	90
5	3567.5	-61.80	5.20	11.15	Vertical	-58.0	-13.0	45.0	270
6	4281	-59.40	5.50	11.95	Vertical	-55.1	-13.0	42.1	225
7	4994.5	-59.40	5.70	13.55	Vertical	-53.7	-13.0	40.7	45
8	5708	-57.50	6.30	13.75	Vertical	-52.2	-13.0	39.2	225
9	6421.5	-56.00	6.80	13.85	Vertical	-51.1	-13.0	38.1	270
10	7135	-56.40	6.90	14.25	Vertical	-51.2	-13.0	38.2	45

- Note: 1.The other Spurious RF Radiated emissions level is no more than noise floor.
 2. The worst emission was found in the antenna is vertical position.

LTE Band 17 QPSK 10MHz CH-Low, RB 1

Harmonic	Frequency (MHz)	SG (dBm)	Cable Loss (dB)	Gain (dBi)	Antenna Polarization	ERP Level (dBm)	Limit (dBm)	Margin (dB)	Azimuth (deg)
2	1418	-64.00	2.00	10.15	Vertical	-58.0	-13.0	45.0	45
3	2127	-64.79	2.51	11.35	Vertical	-58.1	-13.0	45.1	225
4	2836	-60.10	4.20	10.85	Vertical	-55.6	-13.0	42.6	45
5	3545	-62.00	5.20	11.35	Vertical	-58.0	-13.0	45.0	225
6	4254	-59.40	5.50	11.95	Vertical	-55.1	-13.0	42.1	270
7	4963	-59.40	5.70	13.55	Vertical	-53.7	-13.0	40.7	45
8	5672	-57.50	6.30	13.75	Vertical	-52.2	-13.0	39.2	225
9	6381	-56.00	6.80	13.85	Vertical	-51.1	-13.0	38.1	270
10	7090	-56.40	6.90	14.25	Vertical	-51.2	-13.0	38.2	90

- Note: 1.The other Spurious RF Radiated emissions level is no more than noise floor.
 2. The worst emission was found in the antenna is vertical position.

LTE Band 17 QPSK 10MHz CH-Middle, RB 1

Harmonic	Frequency (MHz)	SG (dBm)	Cable Loss (dB)	Gain (dBi)	Antenna Polarization	ERP Level (dBm)	Limit (dBm)	Margin (dB)	Azimuth (deg)
2	1420	-64.60	2.00	10.75	Vertical	-58.0	-13.0	45.0	225
3	2130	-64.49	2.51	11.05	Vertical	-58.1	-13.0	45.1	45
4	2840	-60.40	4.20	11.15	Vertical	-55.6	-13.0	42.6	225
5	3550	-61.80	5.20	11.15	Vertical	-58.0	-13.0	45.0	225
6	4260	-59.40	5.50	11.95	Vertical	-55.1	-13.0	42.1	270
7	4970	-59.40	5.70	13.55	Vertical	-53.7	-13.0	40.7	90
8	5680	-57.50	6.30	13.75	Vertical	-52.2	-13.0	39.2	45
9	6390	-56.00	6.80	13.85	Vertical	-51.1	-13.0	38.1	225
10	7100	-56.40	6.90	14.25	Vertical	-51.2	-13.0	38.2	45

Note: 1.The other Spurious RF Radiated emissions level is no more than noise floor.

2. The worst emission was found in the antenna is vertical position.

LTE Band 17 QPSK 10MHz CH-High, RB 1

Harmonic	Frequency (MHz)	SG (dBm)	Cable Loss (dB)	Gain (dBi)	Antenna Polarization	ERP Level (dBm)	Limit (dBm)	Margin (dB)	Azimuth (deg)
2	1422	-64.00	2.00	10.15	Vertical	-58.0	-13.0	45.0	270
3	2133	-64.80	2.50	11.35	Vertical	-58.1	-13.0	45.1	225
4	2844	-60.10	4.20	10.85	Vertical	-55.6	-13.0	42.6	45
5	3555	-62.00	5.20	11.35	Vertical	-58.0	-13.0	45.0	45
6	4266	-59.40	5.50	11.95	Vertical	-55.1	-13.0	42.1	225
7	4977	-59.40	5.70	13.55	Vertical	-53.7	-13.0	40.7	45
8	5688	-57.50	6.30	13.75	Vertical	-52.2	-13.0	39.2	225
9	6399	-56.00	6.80	13.85	Vertical	-51.1	-13.0	38.1	45
10	7110	-56.40	6.90	14.25	Vertical	-51.2	-13.0	38.2	225

Note: 1.The other Spurious RF Radiated emissions level is no more than noise floor.

2. The worst emission was found in the antenna is vertical position.

5 Main Test Instruments

Name	Manufacturer	Type	Serial Number	Calibration Date	Expiration Time
Base Station Simulator	R&S	CMW500	113645	2017-05-14	2018-05-13
Power Splitter	Hua Xiang	SHX-GF2-2-13	10120101	2017-05-14	2018-05-13
Universal Radio Communication Tester	Agilent	E5515C	MY48367192	2017-05-14	2018-05-13
Spectrum Analyzer	Agilent	N9010A	MY47191109	2017-05-14	2018-05-13
Signal Analyzer	R&S	FSV30	100815	2016-12-16	2017-12-15
Signal generator	R&S	SMB 100A	102594	2017-05-14	2018-05-13
EMI Test Receiver	R&S	ESCI	100948	2017-05-20	2018-05-19
Trilog Antenna	SCHWARZBECK	VUBL 9163	9163-201	2014-12-06	2017-12-05
Horn Antenna	R&S	HF907	100126	2014-12-06	2017-12-05
Horn Antenna	ETS-Lindgren	3160-09	00102643	2015-01-30	2018-01-29
Climatic Chamber	Re Ce	PT-30B	20101891	2015-07-18	2018-07-17
RF Cable	Agilent	SMA 15cm	0001	2017-08-04	2018-02-03
Preamplifier	R&S	SCU18	102327	2017-06-18	2018-06-17

ANNEX A: EUT Appearance and Test Setup

A.1 EUT Appearance

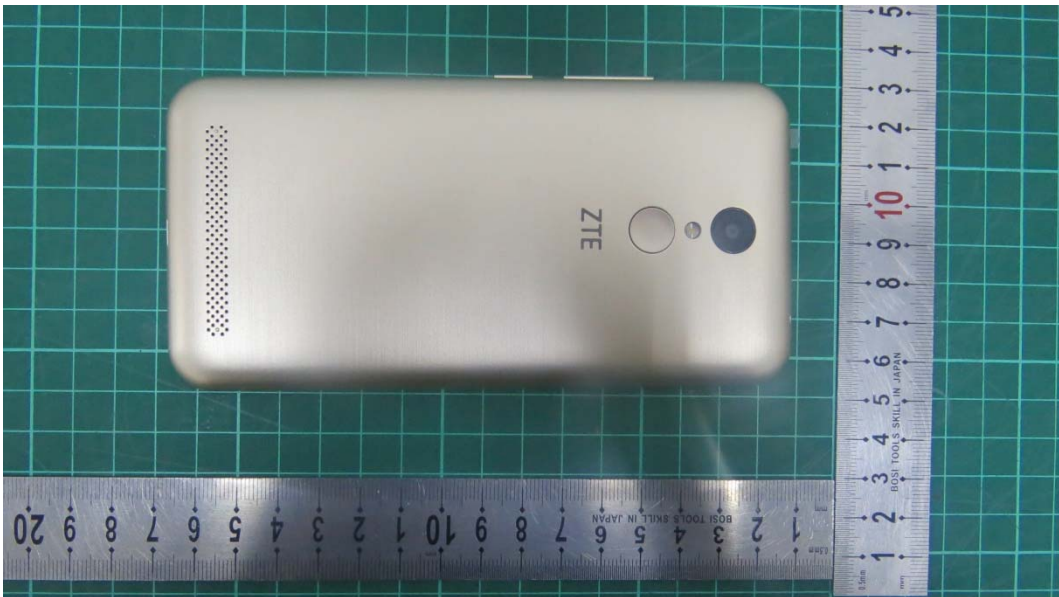

a: EUT



b: Adapter

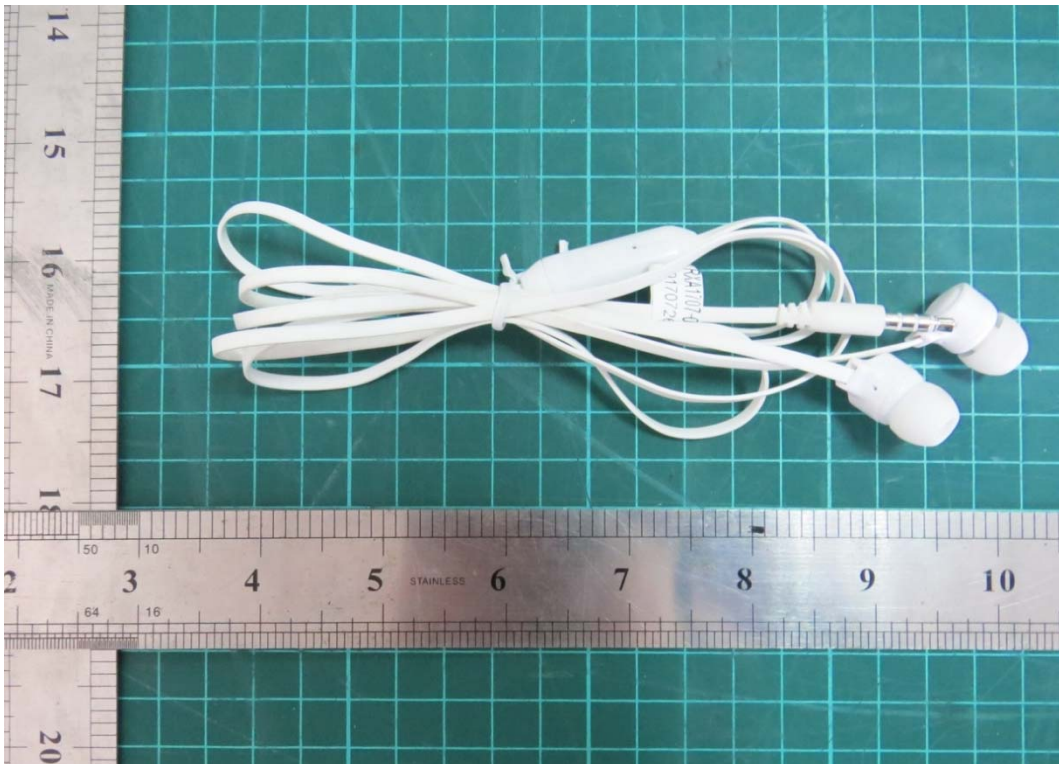

c: Earphone

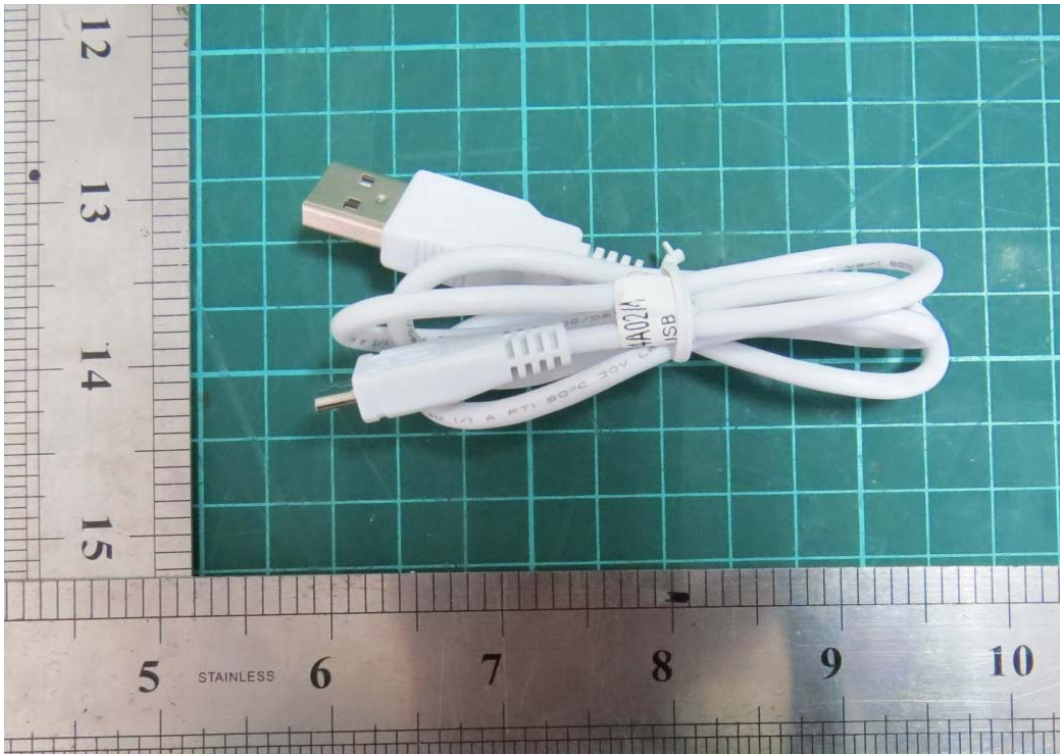

d: USB Cable

Picture 1 EUT and Accessory

A.2 Test Setup

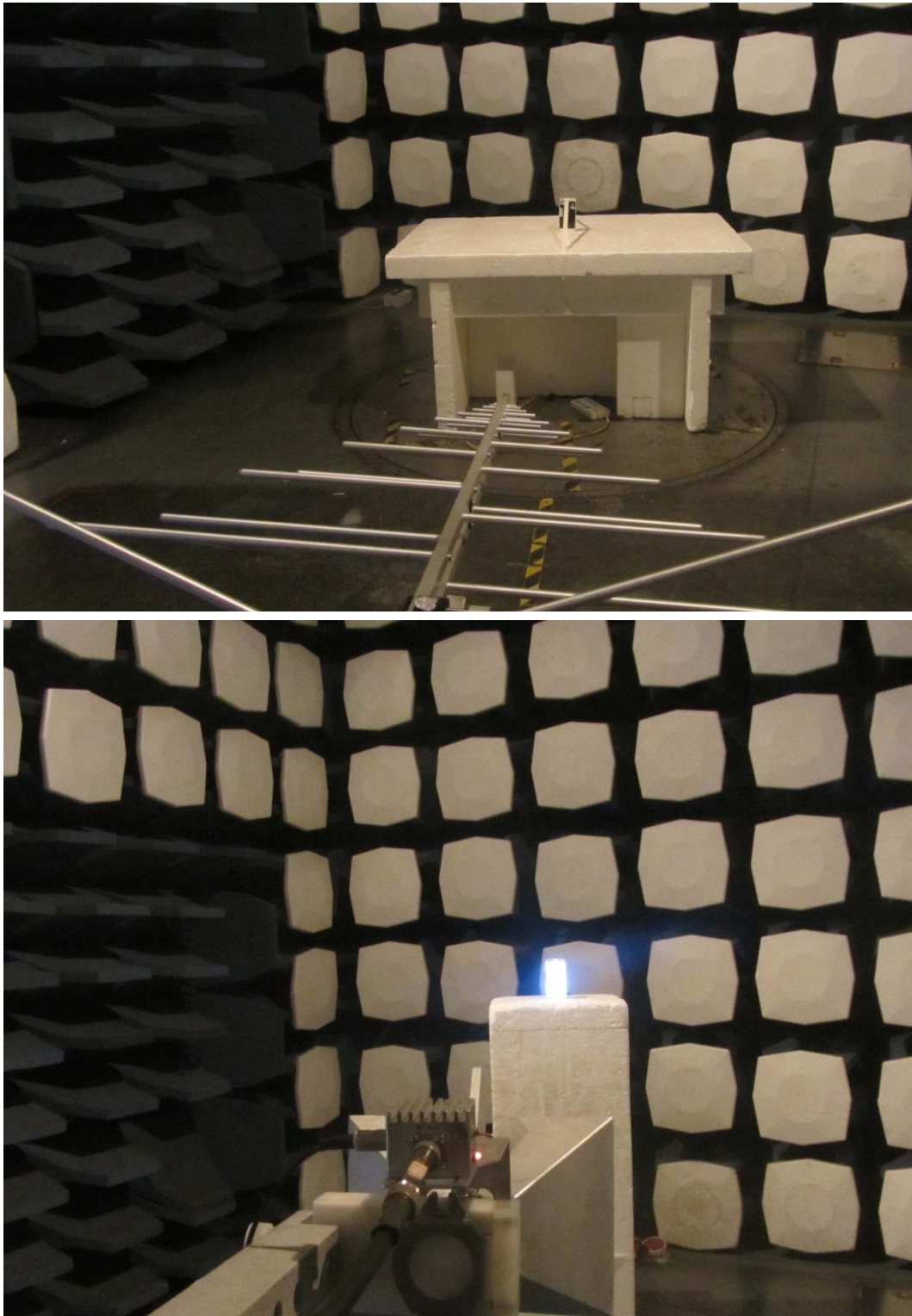

Picture 2: Radiated Spurious Emissions Test setup