



FCC SAR TEST REPORT

Report No. : SET2019-01219

Product : LTE/WCDMA/GSM (GPRS) Multi-Mode Digital Mobile Phone

Brand Name: ZTE

Model No. : ZTE Blade V10

FCC ID : SRQ-BLADEV10M

Applicant : ZTE Corporation

Address : ZTE Plaza, Keji Road South, Shenzhen, China

Issued by : CCIC Southern Electronic Product Testing (Shenzhen) Co., Ltd.

Lab Location : Building 28/29, East of Shigu Xili Industrial Zone, Nanshan District
Shenzhen, Guangdong 518055, China

Tel : 86 755 26627338 **Fax:** 86 755 26627238

Mail : manager@ccic-set.com **Website:** <http://www.ccic-set.com>

This test report consists of 70 pages in total. It may be duplicated completely for legal use with the approval of the applicant. It should not be reproduced except in full, without the written approval of our laboratory. The client should not use it to claim product endorsement by CCIC-SET. The test results in the report only apply to the tested sample. The test report shall be invalid without all the signatures of testing engineers, reviewer and approver. Any objections must be raised to CCIC-SET within 15 days since the date when the report is received. It will not be taken into consideration beyond this limit.



Test Report

Product: LTE/WCDMA/GSM (GPRS) Multi-Mode Digital Mobile Phone

Model No.: ZTE Blade V10

Brand Name.....: ZTE

FCC ID.....: SRQ-BLADEV10M

Applicant.....: ZTE Corporation

Applicant Address.....: ZTE Plaza, Keji Road South, Shenzhen, China

Manufacturer.....: ZTE Corporation

Manufacturer Address: ZTE Plaza, Keji Road South, Shenzhen, China

Test Standards.....: **47CFR § 2.1093-** Radiofrequency Radiation Exposure Evaluation: Portable Devices;
ANSI C95.1–1992: Safety Levels with Respect to Human Exposure to Radio Frequency Electromagnetic Fields, 3 kHz – 300 GHz.(IEEE Std C95.1-1991)
IEEE 1528–2013: IEEE Recommended Practice for Determining the Peak Spatial-Average Specific Absorption Rate (SAR) in the Human Head from Wireless Communications Devices: Measurement Techniques

Test Result.....: Pass

Test Date.....: 2018.12.17-2019.1.9

Tested by: Mei Chun 2019-01-10
Mei Chun, Test Engineer

Reviewed by.....: Chris You 2019-01-10
Chris You, Senior Engineer

Approved by.....: Shuangwen Zhang 2019-01-10
Shuangwen Zhang, Manager



Contents

Test Report.....	2
1. Administrative Data.....	4
2. Equipment Under Test (EUT).....	5
3. SAR Summary.....	7
4. Specific Absorption Rate (SAR).....	9
5. Tissue check and recommend Dielectric Parameters.....	13
6. SAR measurement procedure.....	19
7. Conducted RF Output Power.....	20
8. SAR test Exclusion and estimate SAR calculation:.....	47
9. Scaling Factor calculation.....	50
10. Test Results.....	52
11. Simultaneous Transmissions Analysis.....	63
12. Measurement Uncertainty.....	65
13. Equipment List.....	69
ANNEX A: Appendix A: SAR System performance Check Plots.....	70
ANNEX B: Appendix B: SAR Measurement results Plots.....	70
ANNEX C: Appendix C: Calibration reports.....	70
ANNEX D: Appendix D: SAR Test Setup.....	70



1. Administrative Data

1.1 Testing Laboratory

Test Site: CCIC Southern Electronic Product Testing (Shenzhen) Co., Ltd

Address: Electronic Testing Building, No. 43 Shahe Road, Xili Jiedao, Nanshan District, Shenzhen, Guangdong, China

CNAS Lab Code: CCIC-SET is a third party testing organization accredited by China National Accreditation Service for Conformity Assessment (CNAS) according to ISO/IEC 17025. The accreditation certificate number is L1659.

NVLAP Lab Code: CCIC-SET is a third party testing organization accredited by NVLAP according to ISO/IEC 17025. The accreditation certificate number is 201008-0.

FCC Registration: CCIC Southern Electronic Product Testing (Shenzhen) Co., Ltd. EMC Laboratory has been registered and fully described in a report filed with the FCC (Federal Communications Commission). The acceptance letter from the FCC is maintained in our files. Designation Number: CN5031, valid time is until December 31, 2019.

ISED Registration: CCIC Southern Electronic Product Testing (Shenzhen) Co., Ltd. EMC Laboratory has been registered by Certification and Engineering Bureau of Industry Canada for the performance of radiated measurements with Registration No. 11185A-1 on Aug. 04, 2016, valid time is until Aug. 03, 2019.

Test Environment Temperature (°C): 21°C

Condition: Relative Humidity (%): 60%

Atmospheric Pressure (kPa): 86KPa-106KPa



2. Equipment Under Test (EUT)

Identification of the Equipment under Test

Device Type:	Portable	
Exposure Category:	Population/Uncontrolled	
Sample Name:	LTE/WCDMA/GSM (GPRS) Multi-Mode Digital Mobile Phone	
Brand Name:	ZTE	
Model Name:	ZTE Blade V10	
	Support Band	GSM850MHz/1900/900/1800MHz, WCDMA 850MHz/1900MHz, LTE Band2/3/4/5/7/12/28/66,WIFI 2.4G/5G, BT,GPS
	Test Band	GSM850MHz/1900MHz, WCDMA 850MHz /1900MHz, LTE Band 2/4/5/7/12/66,WIFI2.4G/5G
	IMEI No.	863484040000798/8634840400001614
	Device Class	Class B
	Multi Class	GPRS: Class 12; EGPRS: Class 12
	Development Stage	Identical Prototype
General description:	Accessories	Power Supply
	Hotspot	2.4GHz WLAN support Hotspot mode
	Antenna type	Internal Antenna
	Operation mode	GSM /WCDMA / LTE /WIFI
	Modulation mode	GSM(GMSK),UMTS(QPSK),LTE(QPSK,16QAM,64QAM), WIFI(OFDM/DSSS) ,BT(GFSK/ π /4-DQPSK/8-DPSK)
	DTM mode	Not support
	Hardware Version	ujdA
	Software Version	TEL_MX_ZTE_Blade_V10V1.0
	Max. RF Power	32.13dBm
	Max. SAR Value	Head: 0.534 W/Kg Body: 0.709 W/Kg(Limit:1.6W/Kg, 10mm distance)

NOTE:

- a. The above EUT's information was declared by manufacturer. Please refer to the specifications or user's manual for more detailed description.



EUT testing configuration

Tested frequency range(s)	Transmitter Frequency Range	Receiver Frequency Range
GSM850:	824-849 MHz	869-894 MHz
GSM1900:	1850-1910 MHz	1930-1990 MHz
UMTS Band II:	1850-1910 MHz	1930-1990 MHz
UMTS Band V:	824-849 MHz	869-894 MHz
LTE Band2:	1850-1910 MHz	1930-1990 MHz
LTE Band4:	1710-1755 MHz	2110-2155 MHz
LTE Band5:	824-849 MHz	869-894 MHz
LTE Band7:	2500-2570 MHz	2620-2690 MHz
LTE Band12:	698-716 MHz	728-746 MHz
LTE Band66	1710-1780MHz	
WIFI(tested):	2412-2462 MHz	
	5180-5240 MHz	
	5745-5825MHz	
Bluetooth:	2402-2480 MHz	
Test channels(low-mid-high):	128-190-251(GSM850)	
	512-661-810(GSM1900)	
	9262-9400-9538(UMTS Band II)	
	4132-4183-4233(UMTS Band V)	
	18700-18900-19100(LTE Band 2 Bandwidth 20M)	
	20050-20175-20300(LTE Band 4 Bandwidth 20M)	
	20450-20525-20600(LTE Band 5 Bandwidth 10M)	
	20850-21100-21350(LTE Band 7 Bandwidth 20M)	
	23060-23095-23130(LTE Band 12 Bandwidth 10M)	
	131979-132422-132572(LTE Band 66 Bandwidth 20M)	
	1-6-11(Wife 2.4G 802.11b)	
	Ch 36 (802.11ac40)	
	Ch 151 (802.11ac40)	



3. SAR Summary

Highest Standalone SAR Summary

Exposure Position	Frequency Band	Scaled 1g-SAR(W/kg)	Highest Scaled 1g-SAR(W/kg)
Head	GSM850	0.156	0.534
	GSM1900	0.115	
	WCDMA Band V	0.264	
	WCDMA Band II	0.067	
	LTE Band 2	0.067	
	LTE Band 4	0.079	
	LTE Band 5	0.082	
	LTE Band 7	0.112	
	LTE Band 12	0.101	
	LTE Band 66	0.153	
	WIFI 2.4G 802.11b	0.534	
	WIFI 5G 802.11ac	0.523	
BT	0.023		

Exposure Position	Frequency Band	Scaled 1g-SAR(W/kg)	Highest Scaled 1g-SAR(W/kg)
Body-worn (10mm Gap)	GSM850	0.437	0.709
	GSM1900	0.308	
	WCDMA Band V	0.304	
	WCDMA Band II	0.305	
	LTE Band 2	0.112	
	LTE Band 4	0.248	
	LTE Band 5	0.182	
	LTE Band 7	0.709	
	LTE Band 12	0.347	
	LTE Band 66	0.510	
	WIFI 2.4G 802.11b	0.203	
	WIFI 5G 802.11ac	0.162	
BT	0.011		



Exposure Position	Frequency Band	Scaled 1g-SAR(W/kg)	Highest Scaled 1g-SAR(W/kg)
Hotspot (10mm Gap)	GSM850	0.437	0.709
	GSM1900	0.308	
	WCDMA Band V	0.304	
	WCDMA Band II	0.305	
	LTE Band 2	0.112	
	LTE Band 4	0.248	
	LTE Band 5	0.182	
	LTE Band 7	0.709	
	LTE Band 12	0.347	
	LTE Band 66	0.510	
	WIFI 2.4G 802.11b	0.203	

Highest Simultaneous SAR Summary

Exposure Position	Frequency Band	Highest Scaled 1g-SAR(W/kg)
Hotspot (10mmGap)	WWAN(LTE Band7)&WIFI 2.4G	0.912

4. Specific Absorption Rate (SAR)

4.1 Introduction

SAR is related to the rate at which energy is absorbed per unit mass in an object exposed to a radio field. The SAR distribution in a biological body is complicated and is usually carried out by experimental techniques or numerical modeling. The standard recommends limits for two tiers of groups, occupational/controlled and general population/uncontrolled, based on a person's awareness and ability to exercise control over his or her exposure. In general, occupational/controlled exposure limits are higher than the limits for general population/uncontrolled.

The SAR definition is the time derivative (rate) of the incremental energy (dW) absorbed by (dissipated in) an incremental mass (dm) contained in a volume element (dv) of a given density (ρ). The equation description is as below:

$$\text{SAR} = \frac{d}{dt} \left(\frac{dW}{dm} \right) = \frac{d}{dt} \left(\frac{dW}{\rho dv} \right)$$

SAR is expressed in units of Watts per kilogram (W/kg)

SAR measurement can be either related to the temperature elevation in tissue by

$$\text{SAR} = C \frac{\delta T}{\delta t}$$

where C is the specific heat capacity, δT is the temperature rise and δt the exposure duration, or related to the electrical field in the tissue by

$$\text{SAR} = \frac{\sigma |E|^2}{\rho}$$

where σ is the conductivity of the tissue, ρ is the mass density of the tissue and E is the rms electrical field strength.

However for evaluating SAR of low power transmitter, electrical field measurement is typically applied.



4.2 Applicable Standards and Limits

4.2.1 Applicable Standards

47CFR § 2.1093	Radiofrequency Radiation Exposure Evaluation: Portable Devices
ANSI C95.1-1992	Safety Levels with Respect to Human Exposure to Radio Frequency Electromagnetic Fields, 3 kHz – 300 GHz.(IEEE Std C95.1-1991)
IEEE 1528-2013	IEEE Recommended Practice for Determining the Peak Spatial-Average Specific Absorption Rate (SAR) in the Human Head from Wireless Communications Devices: Measurement Techniques
KDB 248227 D01	v02r02 802.11 Wi-Fi SAR
KDB 447498 D01	v06 General RF Exposure Guidance
KDB 648474 D04	v01r03 Handset SAR
KDB 865664 D01	v01r04 SAR Measurement 100MHz to 6GHz
KDB 865664 D02	v01r02 SAR Exposure Reporting
KDB 941225 D01	v03r01 3G SAR Procedures
KDB 941225 D05	v02r05 SAR for LTE Devices
KDB 941225 D05A	v01r02 LTE Rel.10 KDB Inquiry Sheet
KDB 941225 D06	v02r01 Hotspot Mode

4.2.2 RF exposure Limits

Human Exposure	Uncontrolled Environment General Population
Spatial Peak SAR* (Brain/Body)	1.60 mW/g
Spatial Average SAR** (Whole Body)	0.08 mW/g
Spatial Peak SAR*** (Limbs)	4.00 mW/g

The limit applied in this test report is shown in bold letters.

Notes:

* The Spatial Peak value of the SAR averaged over any 10 grams of tissue (defined as a tissue volume in the shape of a cube) and over the appropriate averaging time

** The Spatial Average value of the SAR averaged over the whole body.

*** The Spatial Peak value of the SAR averaged over any 10 grams of tissue (defined as a tissue volume in the shape of a cube) and over the appropriate averaging time.

4.3 Phantoms

The phantom used for all tests i.e. for both system checks and device testing, was the twin-headed "SAM Phantom", manufactured by SATIMO. The SAM twin phantom is a fiberglass shell phantom with 2mm shell thickness (except the ear region, where shell thickness increases to 6mm).

System checking was performed using the flat section, whilst Head SAR tests used the left and right head profile sections. Body SAR testing also used the flat section between the head profiles.



SAM Twin Phantom

4.4 Device Holder

The device was placed in the device holder (illustrated below) that is supplied by SATIMO as an integral part of the COMOSAR test system.

The device holder is designed to cope with the different positions given in the standard. It has two scales for device rotation (with respect to the body axis) and device inclination (with respect to the line between the ear reference points). The rotation centers for both scales is the ear reference point (ERP). Thus the device needs no repositioning when changing the angles.

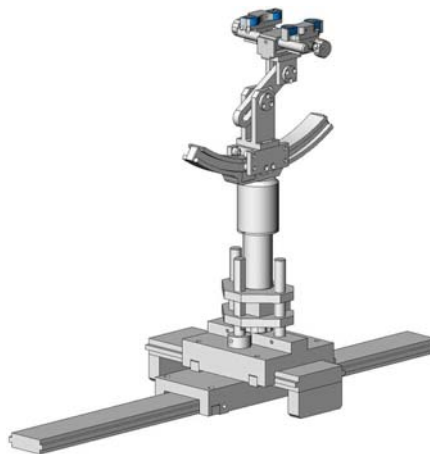

Device holder

4.5 Probe Specification



Construction	Symmetrical design with triangular core Interleaved sensors Built-in shielding against static charges PEEK enclosure material (resistant to organic solvents, e.g., DGBE)
Calibration	ISO/IEC 17025 calibration service available.
Frequency	700 MHz to 3 GHz; Linearity: ± 0.5 dB (700 MHz to 3 GHz)
Directivity	± 0.25 dB in HSL (rotation around probe axis) ± 0.5 dB in tissue material (rotation normal to probe axis)
Dynamic Range	1.5 μ W/g to 100 mW/g; Linearity: ± 0.5 dB
Dimensions	Overall length: 330 mm (Tip: 20 mm) Tip diameter: 5 mm Distance from probe tip to dipole centers: <2.7 mm
Application	General dosimetry up to 3 GHz Dosimetry in strong gradient fields Compliance tests of mobile phones
Compatibility	COMOSAR

Isotropic E-Field Probe

The isotropic E-Field probe has been fully calibrated and assessed for isotropicity, and boundary effect within a controlled environment. Depending on the frequency for which the probe is calibrated the method utilized for calibration will change.

The E-Field probe utilizes a triangular sensor arrangement as detailed in the diagram below:

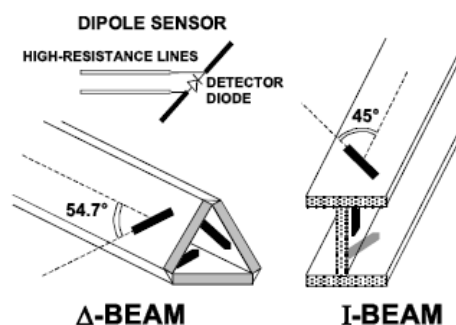

5. Tissue check and recommend Dielectric Parameters

5.1 Tissue Dielectric Parameters for Head and Body Phantoms

The head tissue dielectric parameters recommended by the IEEE SCC-34/SC-2 in P1528 have been incorporated in the following table. These head parameters are derived from planar layer models simulating the highest expected SAR for the dielectric properties and tissue thickness Power drifts in a human head. Other head and body tissue parameters that have not been specified in P1528 are derived from the tissue dielectric parameters computed from the 4-Cole-Cole equations described in Reference [12] and extrapolated according to the head parameters specified in P1528.

Table 1: Recommended Dielectric Performance of Tissue

Ingredients (% by weight)	Frequency (MHz)											
	450		835		915		1900		2450		2600	
Tissue Type	Head	Body	Head	Body	Head	Body	Head	Body	Head	Body	Head	Body
Water	38.56	51.16	41.46	52.4	41.05	56.0	54.9	40.4	62.7	73.2	55.24	64.49
Salt (Nacl)	3.95	1.49	1.45	1.4	1.35	0.76	0.18	0.5	0.5	0.04	0.5	0.024
Sugar	56.32	46.78	56.0	45.0	56.5	41.76	0.0	58.0	0.0	0.0	0.0	0.0
HEC	0.98	0.52	1.0	1.0	1.0	1.21	0.0	1.0	0.0	0.0	0.0	0.0
Bactericide	0.19	0.05	0.1	0.1	0.1	0.27	0.0	0.1	0.0	0.0	0.0	0.0
Triton x-100	0.0	0.0	0.0	0.0	0.0	0.0	0.0	0.0	36.8	0.0	44.45	32.25
DGBE	0.0	0.0	0.0	0.0	0.0	0.0	44.92	0.0	0.0	26.7	0.0	26.7
Dielectric Constant	43.42	58.0	42.54	56.1	42.0	56.8	39.9	54.0	39.2	52.5	39.0	52.5
Conductivity (s/m)	0.85	0.83	0.91	0.95	1.0	1.07	1.42	1.45	1.80	1.78	1.96	2.16

MSL/HSL750 (Body and Head liquid for 650 – 850 MHz)

Item	Head Tissue Simulation Liquid HSL750 Muscle(body)Tissue Simulation Liquid MSL750			
H2O	Water, 35 – 58%			
Sucrose	Sugar, white, refined, 40-60%			
NaCl	Sodium Chloride, 0-6%			
Hydroxyethyl-cellulose	Medium Viscosity (CAS# 9004-62-0), <0.3%			
Preventol-D7	Preservative: aqueous preparation, (CAS# 55965-84-9), containing 5-chloro-2-methyl-3(2H)-isothiazolone and 2-methyl-3(2H)-isothiazolone, 0.1-0.7%			
Frequency (MHz)	Head ϵ_r	Head σ (S/m)	Body ϵ_r	Body σ (S/m)
750	41.9	0.89	55.2	0.97

Note: The liquid of 700MHz&2600MHz typical liquid composition is provided by SATIMO.

Frequency:5200/5400/5600/5800MHz	
Ingredients	(% by weight)
Water	78
Mineral oil	11
Emulsifiers	9
Additives and Salt	2

Table 2 Recommended Tissue Dielectric Parameters

Frequency (MHz)	Head Tissue		Body Tissue	
	ϵ_r	σ (S/m)	ϵ_r	σ (S/m)
150	52.3	0.76	61.9	0.80
300	45.3	0.87	58.2	0.92
450	43.5	0.87	56.7	0.94
835	41.5	0.90	55.2	0.97
900	41.5	0.97	55.0	1.05
915	41.5	0.98	55.0	1.06
1450	40.5	1.20	54.0	1.30
1610	40.3	1.29	53.8	1.40
1800-2000	40.0	1.40	53.3	1.52
2450	39.2	1.80	52.7	1.95
3000	38.5	2.40	52.0	2.73
5800	35.3	5.27	48.2	6.00



5.2 Simulate liquid

Liquid check results:

Table 3: Dielectric Performance of Head Tissue Simulating Liquid

Temperature: 23.2°C; Humidity: 64%;			
/	Frequency	Permittivity ϵ	Conductivity σ (S/m)
Target value	750MHz	41.9 ± 5%	0.89 ± 5%
Validation value (2018-12-23)	750MHz	41.9	0.88
Target value	850MHz	41.5 ± 5%	0.90 ± 5%
Validation value (2018-12-17)	850MHz	41.3	0.89
Target value	1800MHz	40.5 ± 5%	1.40 ± 5%
Validation value (2018-12-18)	1800MHz	40.45	1.41
Target value	1900MHz	40.5 ± 5%	1.40 ± 5%
Validation value (2018-12-18)	1900MHz	40.51	1.42
Target value	2450MHz	39.2 ± 5%	1.80 ± 5%
Validation value (2018-12-19)	2450MHz	39.1	1.82
Target value	2600MHz	39.0 ± 5%	1.96 ± 5%
Validation value (2018-12-20)	2600MHz	39.3	1.98
Target value	5200MHz	36.0 ± 5%	4.66 ± 5%
Validation value (2018-12-24)	5200MHz	36.22	4.52
Target value	5800MHz	35.3 ± 5%	5.27 ± 5%
Validation value (2018-12-25)	5800MHz	35.2	5.25
Target value	2450MHz	39.2 ± 5%	1.80 ± 5%
Validation value (2019-1-09)	2450MHz	38.85	1.81
Target value	2600MHz	39.0 ± 5%	1.96 ± 5%
Validation value (2019-1-10)	2600MHz	39.28	1.99



Dielectric Performance of Body Tissue Simulating Liquid

Temperature: 23.2°C; Humidity: 64%;			
/	Frequency	Permittivity ϵ	Conductivity σ (S/m)
Target value	750MHz	$55.5 \pm 5\%$	$0.96 \pm 5\%$
Validation value (2018-12-23)	750MHz	55.40	0.95
Target value	850MHz	$55.2 \pm 5\%$	$0.97 \pm 5\%$
Validation value (2018-12-17)	850MHz	55.12	0.96
Target value	1800MHz	$53.3 \pm 5\%$	$1.52 \pm 5\%$
Validation value (2018-12-18)	1800MHz	53.36	1.53
Target value	1900MHz	$53.3 \pm 5\%$	$1.52 \pm 5\%$
Validation value (2018-12-18)	1900MHz	53.32	1.51
Target value	2450MHz	$52.7 \pm 5\%$	$1.95 \pm 5\%$
Validation value (2018-12-19)	2450MHz	52.56	1.94
Target value	2600MHz	$52.5 \pm 5\%$	$2.16 \pm 5\%$
Validation value (2018-12-20)	2600MHz	52.45	2.15
Target value	5200MHz	$49.0 \pm 5\%$	$5.30 \pm 5\%$
Validation value (2018-12-24)	5200MHz	49.33	5.12
Target value	5800MHz	$48.2 \pm 5\%$	$6.0 \pm 5\%$
Validation value (2018-12-25)	5800MHz	48.15	5.89
Target value	2450MHz	$52.7 \pm 5\%$	$1.95 \pm 5\%$
Validation value (2019-1-09)	2450MHz	52.53	1.93
Target value	2600MHz	$52.5 \pm 5\%$	$2.16 \pm 5\%$
Validation value (2019-1-10)	2600MHz	52.41	2.13

SAR System validation

Prior to the assessment, the system validation kit was used to test whether the system was operating within its specifications of $\pm 10\%$. The validation results are tabulated below. And also the corresponding SAR plot is attached as well in the SAR plots files.

The following procedure, recommended for performing validation tests using box phantoms is based on the procedures described in the IEEE standard P1528. Setup according to the setup diagram below:

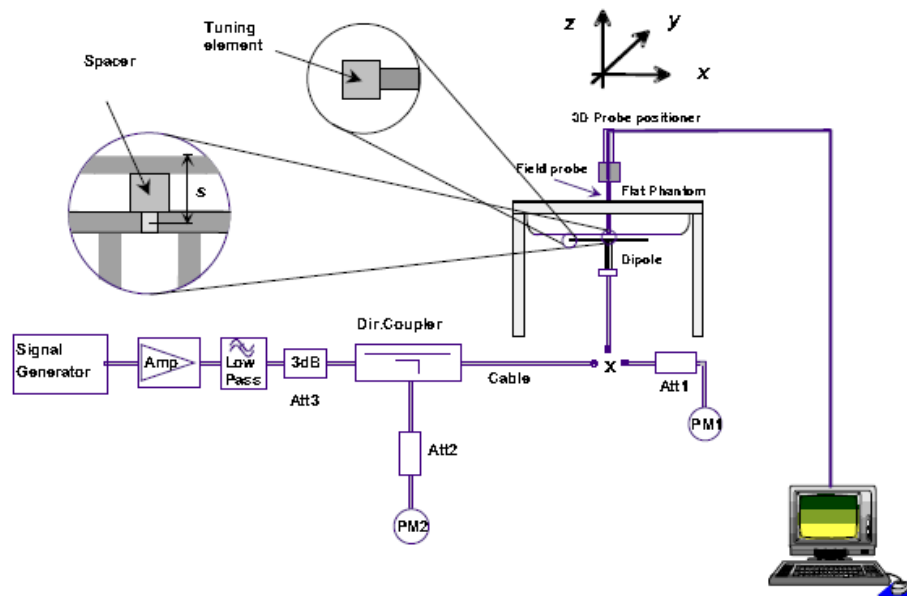

With the SG and Amp and with directional coupler in place, set up the source signal at the relevant frequency and use a power meter to measure the power at the end of the SMA cable that you intend to connect to the balanced dipole. Adjust the SG to make this, say, 0.01W (10 dBm). If this level is too high to read directly with the power meter sensor, insert a calibrated attenuator (e.g. 10 or 20 dB) and make a suitable correction to the power meter reading.

Note 1: In this method, the directional coupler is used for monitoring rather than setting the exact feed power level. If, however, the directional coupler is used for power measurement, you should check the frequency range and power rating of the coupler and measure the coupling factor (referred to output) at the test frequency using a VNA.

Note 2: Remember that the use of a 3dB attenuator (as shown in Figure 8.1 of P1528) means that you need an RF amplifier of 2 times greater power for the same feed power. The other issue is the cable length. You might get up to 1dB of loss per meter of cable, so the cable length after the coupler needs to be quite short.

Note 3: For the validation testing done using CW signals, most power meters are suitable. However, if you are measuring the output of a modulated signal from either a signal generator or a handset, you must ensure that the power meter correctly reads the modulated signals.

The measured 1-gram averaged SAR values of the device against the phantom are provided in Tables 5 and Table 6. The humidity and ambient temperature of test facility

were 64% and 23.2°C respectively. The body phantom were full of the body tissue simulating liquid. The EUT was supplied with full-charged battery for each measurement.

The distance between the back of the EUT and the bottom of the flat phantom is 10 mm (taking into account of the IEEE 1528 and the place of the antenna).

Table 4: Head SAR system validation (1g)

Frequency	Duty cycle	Target value (W/kg)	Test value (W/kg)	
			10 mW	1W
750MHz(2018-12-23)	1:1	8.62 ± 10%	0.0869	8.69
835MHz(2018-12-17)	1:1	9.61 ± 10%	0.0978	9.78
1800MHz(2018-12-18)	1:1	37.35 ± 10%	0.3860	38.60
1900MHz(2018-12-18)	1:1	39.35 ± 10%	0.3951	39.51
2450MHz(2018-12-19)	1:1	52.67 ± 10%	0.5117	51.17
2600MHz(2018-12-20)	1:1	55.47 ± 10%	0.5555	55.55
5200MHz(2018-12-25)	1:1	173.80 ± 10%	1.737	173.7
5800MHz(2018-12-25)	1:1	181.20 ± 10%	1.809	180.9
2450MHz(2019-1-9)	1:1	52.67 ± 10%	0.5278	52.78
2600MHz(2019-1-10)	1:1	55.47 ± 10%	0.5526	55.26

Body SAR system validation (1g)

Frequency	Duty cycle	Target value (W/kg)	Test value (W/kg)	
			10 mW	1W
750MHz(2018-12-17)	1:1	8.68 ± 10%	0.0886	8.86
835MHz(2018-12-17)	1:1	9.88 ± 10%	0.0976	9.76
1800MHz(2018-12-18)	1:1	37.68 ± 10%	0.3944	39.44
1900MHz(2018-12-18)	1:1	38.84 ± 10%	0.3969	39.69
2450MHz(2018-12-19)	1:1	51.42 ± 10%	0.5204	52.04
2600MHz(2018-12-20)	1:1	53.45 ± 10%	0.5202	52.02
5200MHz(2018-12-25)	1:1	167.61 ± 10%	1.663	166.3
5800MHz(2018-12-25)	1:1	170.49 ± 10%	1.710	171.0
2450MHz(2019-1-9)	1:1	51.42 ± 10%	0.5197	51.97
2600MHz(2019-1-10)	1:1	53.45 ± 10%	0.5315	53.15

* Note: Target value was referring to the measured value in the calibration certificate of reference dipole.

Note: All SAR values are normalized to 1W forward power.

6. SAR measurement procedure

The SAR test against the head phantom was carried out as follow:

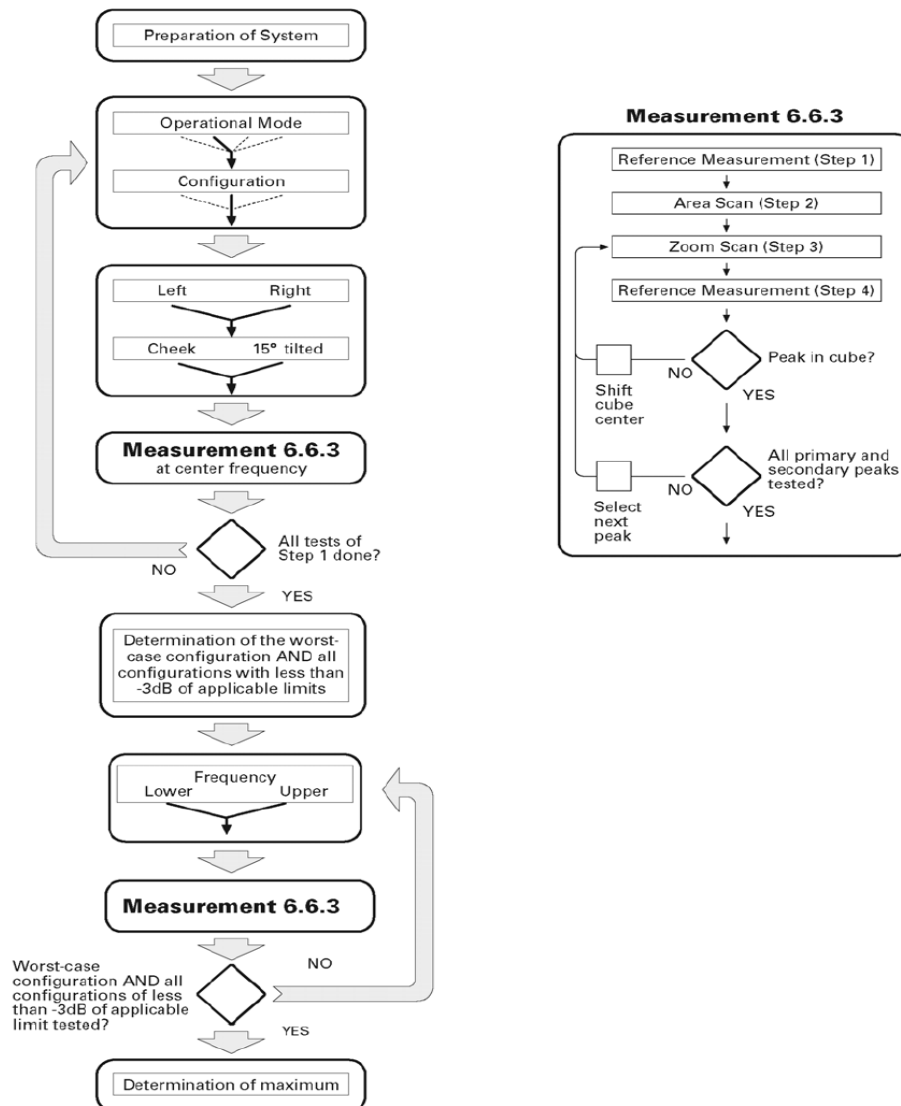

Establish a call with the maximum output power with a base station simulator, the connection between the EUT and the base station simulator is established via air interface.

After an area scan has been done at a fixed distance of 2mm from the surface of the phantom on the source side, a 3D scan is set up around the location of the maximum spot SAR. First, a point within the scan area is visited by the probe and a SAR reading taken at the start of testing. At the end of testing, the probe is returned to the same point and a second reading is taken. Comparison between these start and end readings enables the power drift during measurement to be assessed.

Above is the scanning procedure flow chart and table from the IEEE p1528 standard. This is the procedure for which all compliant testing should be carried out to ensure that all variations of the device position and transmission behavior are tested.

7. Conducted RF Output Power

7.1 GSM Conducted Power

GSM850		Burst-Averaged output Power (dBm)			Division Factors	Frame-Averaged output Power (dBm)		
		128CH	190CH	251CH		28CH	190CH	251CH
GSM (CS)		31.85	32.11	32.09	-9.19	22.66	22.92	22.90
GPRS (GMSK)	1 Tx Slot	31.87	32.13	32.11	-9.19	22.68	22.94	22.92
	2 Tx Slots	28.99	29.02	28.91	-6.13	22.86	22.89	22.78
	3 Tx Slots	27.58	27.54	27.66	-4.42	23.16	23.12	23.24
	4 Tx Slots	26.73	26.85	26.78	-3.18	23.55	23.67	23.60
EDGE (8PSK)	1 Tx Slot	26.34	27.01	26.85	-9.19	17.15	17.82	17.66
	2 Tx Slots	23.53	23.56	23.36	-6.13	17.40	17.43	17.23
	3 Tx Slots	22.05	21.99	22.10	-4.42	17.63	17.57	17.68
	4 Tx Slots	21.31	21.42	21.36	-3.18	18.13	18.24	18.18
GSM1900		Burst-Averaged output Power (dBm)			Division Factors	Frame-Averaged output Power (dBm)		
		512CH	661CH	810CH		512CH	661CH	810CH
GSM (CS)		29.36	29.45	29.62	-9.19	20.17	20.26	20.43
GPRS (GMSK)	1 Tx Slot	26.73	26.84	26.88	-9.19	17.54	17.65	17.69
	2 Tx Slots	24.02	24.04	23.93	-6.13	17.89	17.91	17.80
	3 Tx Slots	22.66	22.59	22.69	-4.42	18.24	18.17	18.27
	4 Tx Slots	21.56	21.43	21.31	-3.18	18.38	18.25	18.13
EDGE (8PSK)	1 Tx Slot	27.63	26.87	26.95	-9.19	18.44	17.68	17.76
	2 Tx Slots	24.86	24.88	24.71	-6.13	18.73	18.75	18.58
	3 Tx Slots	23.38	23.27	23.38	-4.42	18.96	18.85	18.96
	4 Tx Slots	22.52	22.58	22.57	-3.18	19.34	19.40	19.39

Note: Per KDB 447498 D01 v06, the maximum output power channel is used for SAR testing and for further SAR test reduction.

For hotspot SAR, EUT was performed at GPRS Class 12 multi-slots(4Tx) mode

For Head and Body-worn SAR testing, EUT was set in GSM Voice mode for both GSM850 and GSM1900

Timeslot consignations

No. Of Slots	Slot 1	Slot 2	Slot 3	Slot 4
Slot Consignation	1Up4Down	2UpDown	3UpDown	4Up1Down
Duty Cycle	1:8	1:4	1:2.67	1:2
Crest Factor	-9.03dB	-6.02dB	-4.26dB	-3.01dB



7.2 WCDMA Conducted output Power

Item	band	WCDMA 850			WCDMA 1900		
	Frequency	4132	4183	4233	9262	9400	9538
	Subtest	dBm			dBm		
WCDMA	RMC 12.2Kbps	22.71	22.84	22.79	22.38	22.30	22.19
HSDPA	1	22.57	22.72	22.65	22.05	22.45	22.54
	2	21.65	21.71	21.78	21.88	21.65	21.75
	3	21.60	21.32	21.62	21.60	21.59	21.57
	4	21.54	21.48	21.47	21.46	21.39	21.38
HSUPA	1	22.45	22.77	22.63	22.01	22.25	22.13
	2	21.61	21.60	21.60	21.59	21.62	21.53
	3	21.41	21.38	21.53	21.42	21.40	21.35
	4	21.34	21.31	21.37	21.35	21.28	21.29
	5	21.26	21.25	21.30	21.18	21.20	21.14

Note:

1. WCDMA SAR was tested under RMC 12.2kbps with HSPA Inactive per KDB Publication 941225 D01v03r01. HSPA SAR was not required since the average output power of the HSPA subtests was not more than 0.25dB higher than the RMC level and SAR was less than 1.2W/kg.
2. It is expected by the manufacturer that MPR for some HSPA subtests may be up to 2dB more than specified by 3GPP, but also as low as 0dB according to the chipset implementation in this model

7.3 LTE Conducted peak output Power

LTE Test Configurations

The CMW500 Wide Band Radio Communication Tester was used for LTE output power measurements and SAR testing. Closed loop power control was used so the UE transmits with maximum output power during SAR testing. SAR test were performed with the same number of RB and RB offsets transmitting on all frames.

1) Spectrum Plots for RB configurations

A properly configured base station simulator was used for LTE output power measurements and SAR testing. Therefore, spectrum plots for RB configurations were not required to be included in this report.

2) MPR

When MPR is implemented permanently within the UE, regardless of network requirements, only those RB configurations allowed by 3GPP for the channel bandwidth and modulation combinations may be tested with MPR active. Configurations with RB allocations less than the RB thresholds required by 3GPP must be tested without MPR.

The allowed Maximum Power Reduction(MPR) for the maximum output power due to higher order modulation and transmit bandwidth configuration (resource blocks) is specified in Table 6.2.3-1 of the 3GPP TS36.101:

Table 6.2.3-1: Maximum Power Reduction (MPR) for Power Class 3

Modulation	Channel bandwidth / Transmission bandwidth configuration [RB]						MPR (dB)
	1.4 MHz	3.0 MHz	5 MHz	10 MHz	15 MHz	20 MHz	
QPSK	> 5	> 4	> 8	> 12	> 16	> 18	≤ 1
16 QAM	≤ 5	≤ 4	≤ 8	≤ 12	≤ 16	≤ 18	≤ 1
16 QAM	> 5	> 4	> 8	> 12	> 16	> 18	≤ 2

3)A-MPR LTE procedures for SAR testing

A-MPR(Additional MPR) has been disabled for all SAR tests by using Network Signaling Value of "NS_01" on the base station simulator.

4)LTE procedures for SAR testing

A) Largest channel bandwidth standalone SAR test

requirements i) QPSK with 1 RB allocation

Start with the largest channel bandwidth and measure SAR for QPSK with 1 RB allocation, using the RB offset and required test channel combination with the highest maximum output power for RB offsets at the upper edge, middle and lower edge of each required test channel. When the reported SAR is $\leq 0.8W/kg$, testing of the remaining RB offset configurations and required test channels is not required for 1RB allocation; otherwise, SAR is required for the remaining required test channels and only for the RB offset configuration with the highest output power for that channel. When the reported SAR of a required test channel is $> 1.45 W/kg$, SAR is required for all three RB offset configurations for that required test channel.

5) LTE CA operation

4.3.1.1.7A FDD reference test frequencies for CA in operating band 7

Table 4.3.1.1.7A-1: Test frequencies for CA_7C

Range	CC-Combo / N _{RB,agg} [RB]	CC1 Note1					CC2 Note1				
		BW [RB]	N _{UL}	f _{UL} [MHz]	N _{DL}	f _{DL} [MHz]	BW [RB]	N _{UL}	f _{UL} [MHz]	N _{DL}	f _{DL} [MHz]
Low	50+100	50	20805	2505.5	2805	2625.5	100	20949	2519.9	2949	2639.9
		100	20850	2510	2850	2630	50	20994	2524.4	2994	2644.4
	75+50	75	20825	2507.5	2825	2627.5	50	20945	2519.5	2945	2639.5
	75+75	75	20825	2507.5	2825	2627.5	75	20975	2522.5	2975	2642.5
	75+100	75	20828	2507.8	2828	2627.8	100	20999	2524.9	2999	2644.9
		100	20850	2510	2850	2630	75	21021	2527.1	3021	2647.1
100+100	100	20850	2510	2850	2630	100	21048	2529.8	3048	2649.8	
Mid	50+100	50	21006	2525.6	3006	2645.6	100	21150	2540	3150	2660
		100	21051	2530.1	3051	2650.1	50	21195	2544.5	3195	2664.5
	75+50	75	21051	2530.1	3051	2650.1	50	21171	2542.1	3171	2662.1
	75+75	75	21025	2527.5	3025	2647.5	75	21175	2542.5	3175	2662.5
	75+100	75	21003	2525.3	3003	2645.3	100	21174	2542.4	3174	2662.4
		100	21026	2527.6	3026	2647.6	75	21197	2544.7	3197	2664.7
100+100	100	21001	2525.1	3001	2645.1	100	21199	2544.9	3199	2664.9	
High	50+100	50	21206	2545.6	3206	2665.6	100	21350	2560	3350	2680
		100	21251	2550.1	3251	2670.1	50	21395	2564.5	3395	2684.5
	75+50	75	21277	2552.7	3277	2672.7	50	21397	2564.7	3397	2684.7
	75+75	75	21225	2547.5	3225	2667.5	75	21375	2562.5	3375	2682.5
	75+100	75	21179	2542.9	3179	2662.9	100	21350	2560	3350	2680
		100	21201	2545.1	3201	2665.1	75	21372	2562.2	3372	2682.2
100+100	100	21152	2540.2	3152	2660.2	100	21350	2560	3350	2680	

Note 1: Carriers in increasing frequency order.

1. LTE Band 2 Conducted Power Test Verdict:

LTE FDD Band 2				Conducted Power(dBm)		
Bandwidth	Modulation	RB size	RB offset	Channel	Channel	Channel
				18607	18900	19193
1.4MHz	QPSK	1	0	21.95	22.02	22.15
		1	3	21.82	21.92	22.03
		1	5	21.84	21.91	22.02
		3	0	21.12	21.2	21.3
		3	2	21.13	21.19	21.27
		3	3	21.14	21.21	21.28
		6	0	21	21.08	21.17
	16QAM	1	0	20.82	20.87	21.04
		1	3	20.67	20.76	20.91
		1	5	20.8	20.84	21.03
		3	0	19.89	19.95	20.22
		3	2	19.97	20.05	20.25
		3	3	19.99	20.06	20.19
		6	0	19.87	19.96	20.04



Bandwidth	Modulation	RB size	RB offset	Channel	Channel	Channel
				18615	18900	19185
3MHz	QPSK	1	0	22.12	22.23	22.19
		1	7	21.99	22.13	22.07
		1	14	22.01	22.12	22.06
		8	0	21.29	21.41	21.34
		8	4	21.3	21.4	21.31
		8	7	21.31	21.42	21.32
		15	0	21.17	21.29	21.21
	16QAM	1	0	20.99	21.08	21.08
		1	7	20.84	20.97	20.95
		1	14	20.97	21.05	21.07
		8	0	20.06	20.16	20.26
		8	4	20.14	20.26	20.29
		8	7	20.16	20.27	20.23
		15	0	20.04	20.17	20.08
Bandwidth	Modulation	RB size	RB offset	Channel	Channel	Channel
				18625	18900	19175
5MHz	QPSK	1	0	22.16	22.27	22.23
		1	13	22.03	22.17	22.11
		1	24	22.05	22.16	22.1
		12	0	21.33	21.45	21.38
		12	6	21.34	21.44	21.35
		12	13	21.35	21.46	21.36
		25	0	21.21	21.33	21.25
	16QAM	1	0	21.03	21.12	21.12
		1	13	20.88	21.01	20.99
		1	24	21.01	21.09	21.11
		12	0	20.1	20.2	20.3
		12	6	20.18	20.3	20.33
		12	13	20.2	20.31	20.27
		25	0	20.08	20.21	20.12



Bandwidth	Modulation	RB size	RB offset	Channel	Channel	Channel
				18650	18900	19150
10MHz	QPSK	1	0	22.32	22.41	22.38
		1	25	22.19	22.31	22.26
		1	49	22.21	22.3	22.25
		25	0	21.49	21.59	21.53
		25	13	21.5	21.58	21.5
		25	25	21.51	21.6	21.51
		50	0	21.37	21.47	21.4
	16QAM	1	0	21.19	21.26	21.27
		1	25	21.04	21.15	21.14
		1	49	21.17	21.23	21.26
		25	0	20.26	20.34	20.45
		25	13	20.34	20.44	20.48
		25	25	20.36	20.45	20.42
		50	0	20.24	20.35	20.27
Bandwidth	Modulation	RB size	RB offset	Channel	Channel	Channel
				18675	18900	19125
15MHz	QPSK	1	0	22.15	22.1	22.22
		1	38	22.02	22	22.1
		1	74	22.04	21.99	22.09
		36	0	21.32	21.28	21.37
		36	18	21.33	21.27	21.34
		36	39	21.34	21.29	21.35
		75	0	21.2	21.16	21.24
	16QAM	1	0	21.02	20.95	21.11
		1	38	20.87	20.84	20.98
		1	74	21	20.92	21.1
		36	0	20.09	20.03	20.29
		36	18	20.17	20.13	20.32
		36	39	20.19	20.14	20.26
		75	0	20.07	20.04	20.11



Bandwidth	Modulation	RB size	RB offset	Channel	Channel	Channel
				18700	18900	19100
20MHz	QPSK	1	0	22.41	22.51	22.48
		1	50	22.28	22.41	22.36
		1	99	22.3	22.4	22.35
		50	0	21.58	21.69	21.63
		50	25	21.59	21.68	21.6
		50	50	21.6	21.7	21.61
		100	0	21.46	21.57	21.5
	16QAM	1	0	21.28	21.36	21.37
		1	50	21.13	21.25	21.24
		1	99	21.26	21.33	21.36
		50	0	20.35	20.44	20.55
		50	25	20.43	20.54	20.58
		50	50	20.45	20.55	20.52
		100	0	20.33	20.45	20.37

2. LTE Band 4 Conducted Power Test Verdict:

LTE FDD Band 4				Conducted Power(dBm)		
Bandwidth	Modulation	RB size	RB offset	Channel	Channel	Channel
				19957	20175	20393
1.4MHz	QPSK	1	0	21.85	21.91	22.03
		1	3	21.72	21.81	21.91
		1	5	21.74	21.8	21.9
		3	0	21.02	21.09	21.18
		3	2	21.03	21.08	21.15
		3	3	21.04	21.1	21.16
	16QAM	1	0	20.72	20.76	20.92
		1	3	20.57	20.65	20.79
		1	5	20.7	20.73	20.91
		3	0	19.79	19.84	20.1
		3	2	19.87	19.94	20.13
		3	3	19.89	19.95	20.07
		6	0	19.77	19.85	19.92
		15	1	0	20.07	20.17
15	0		20.07	20.17	20.02	
3MHz	QPSK	1	0	22.15	22.23	22.13
		1	7	22.02	22.13	22.01
1		14	22.04	22.12	22	
8		0	21.32	21.41	21.28	
8		4	21.33	21.4	21.25	
8		7	21.34	21.42	21.26	
15		0	21.2	21.29	21.15	
16QAM		1	0	21.02	21.08	21.02
		1	7	20.87	20.97	20.89
		1	14	21	21.05	21.01
		8	0	20.09	20.16	20.2
		8	4	20.17	20.26	20.23
		8	7	20.19	20.27	20.17
		15	0	20.07	20.17	20.02
	15	0	20.07	20.17	20.02	



Bandwidth	Modulation	RB size	RB offset	Channel	Channel	Channel
				19975	20175	20375
5MHz	QPSK	1	0	22.21	22.25	22.16
		1	13	22.08	22.15	22.04
		1	24	22.1	22.14	22.03
		12	0	21.38	21.43	21.31
		12	6	21.39	21.42	21.28
		12	13	21.4	21.44	21.29
		25	0	21.26	21.31	21.18
	16QAM	1	0	21.08	21.1	21.05
		1	13	20.93	20.99	20.92
		1	24	21.06	21.07	21.04
		12	0	20.15	20.18	20.23
		12	6	20.23	20.28	20.26
		12	13	20.25	20.29	20.2
		25	0	20.13	20.19	20.05
Bandwidth	Modulation	RB size	RB offset	Channel	Channel	Channel
				20000	20175	20350
10MHz	QPSK	1	0	22.23	22.28	22.19
		1	25	22.1	22.18	22.07
		1	49	22.12	22.17	22.06
		25	0	21.4	21.46	21.34
		25	13	21.41	21.45	21.31
		25	25	21.42	21.47	21.32
		50	0	21.28	21.34	21.21
	16QAM	1	0	21.1	21.13	21.08
		1	25	20.95	21.02	20.95
		1	49	21.08	21.1	21.07
		25	0	20.17	20.21	20.26
		25	13	20.25	20.31	20.29
		25	25	20.27	20.32	20.23
		50	0	20.15	20.22	20.08



Bandwidth	Modulation	RB size	RB offset	Channel	Channel	Channel
				20025	20175	20325
15MHz	QPSK	1	0	22.28	22.31	22.26
		1	38	22.15	22.21	22.14
		1	74	22.17	22.2	22.13
		36	0	21.45	21.49	21.41
		36	18	21.46	21.48	21.38
		36	39	21.47	21.5	21.39
		75	0	21.33	21.37	21.28
	16QAM	1	0	21.15	21.16	21.15
		1	38	21	21.05	21.02
		1	74	21.13	21.13	21.14
		36	0	20.22	20.24	20.33
		36	18	20.3	20.34	20.36
		36	39	20.32	20.35	20.3
		75	0	20.2	20.25	20.15
Bandwidth	Modulation	RB size	RB offset	Channel	Channel	Channel
				20050	20175	20300
20MHz	QPSK	1	0	22.31	22.55	22.45
		1	50	22.18	22.45	22.33
		1	99	22.2	22.44	22.32
		50	0	21.48	21.73	21.6
		50	25	21.49	21.72	21.57
		50	50	21.5	21.74	21.58
		100	0	21.36	21.61	21.47
	16QAM	1	0	21.18	21.4	21.34
		1	50	21.03	21.29	21.21
		1	99	21.16	21.37	21.33
		50	0	20.25	20.48	20.52
		50	25	20.33	20.58	20.55
		50	50	20.35	20.59	20.49
		100	0	20.23	20.49	20.34

3. LTE Band 5 Conducted Power Test Verdict:

LTE FDD Band 5				Conducted Power(dBm)		
Bandwidth	Modulation	RB size	RB offset	Channel	Channel	Channel
				20407	20525	20643
1.4MHz	QPSK	1	0	22.13	22.25	22.31
		1	3	22	22.14	22.2
		1	5	21.98	22.1	22.17
		3	0	21.32	21.39	21.45
		3	2	21.28	21.42	21.49
		3	3	21.29	21.41	21.44
	16QAM	6	0	21.14	21.22	21.34
		1	0	21	21.13	21.16
		1	3	20.89	20.98	21.05
		1	5	20.98	21.09	21.14
		3	0	20.09	20.21	20.33
		3	2	20.12	20.3	20.39
		3	3	20.18	20.32	20.3
		6	0	20.04	20.14	20.09
Bandwidth	Modulation	RB size	RB offset	Channel	Channel	Channel
				20415	20525	20635
3MHz	QPSK	1	0	22.18	22.31	22.33
		1	7	22.03	22.17	22.19
		1	14	22.07	22.18	22.18
		8	0	21.36	21.46	21.5
		8	4	21.37	21.49	21.52
		8	7	21.38	21.47	21.45
		15	0	21.2	21.34	21.34
	16QAM	1	0	21.06	21.18	21.16
		1	7	20.91	21.03	21.01
		1	14	21.03	21.12	21.13
		8	0	20.14	20.24	20.35
		8	4	20.2	20.36	20.44
		8	7	20.25	20.34	20.33
		15	0	20.1	20.18	20.09



Bandwidth	Modulation	RB size	RB offset	Channel	Channel	Channel
				20425	20525	20625
5MHz	QPSK	1	0	22.37	22.48	22.36
		1	13	22.22	22.33	22.25
		1	24	22.24	22.36	22.21
		12	0	21.55	21.65	21.55
		12	6	21.56	21.64	21.52
		12	13	21.54	21.61	21.51
		25	0	21.4	21.49	21.36
	16QAM	1	0	21.23	21.36	21.2
		1	13	21.1	21.22	21.06
		1	24	21.18	21.34	21.13
		12	0	20.29	20.44	20.35
		12	6	20.42	20.5	20.48
		12	13	20.41	20.53	20.34
		25	0	20.26	20.42	20.1
Bandwidth	Modulation	RB size	RB offset	Channel	Channel	Channel
				20450	20525	20600
10MHz	QPSK	1	0	22.56	22.66	22.42
		1	25	22.38	22.54	22.27
		1	49	22.4	22.54	22.31
		25	0	21.75	21.83	21.59
		25	13	21.71	21.82	21.6
		25	25	21.73	21.85	21.61
		50	0	21.62	21.7	21.41
	16QAM	1	0	21.43	21.51	21.27
		1	25	21.32	21.4	21.16
		1	49	21.38	21.43	21.24
		25	0	20.52	20.57	20.43
		25	13	20.57	20.62	20.51
		25	25	20.58	20.65	20.39
		50	0	20.45	20.48	20.17

4. LTE Band 7 Conducted Power Test Verdict:

LTE FDD Band 7				Conducted Power(dBm)		
Bandwidth	Modulation	RB size	RB offset	Channel	Channel	Channel
				20775	21100	21425
5MHz	QPSK	1	0	19.85	20.15	20.11
		1	13	19.74	20	19.96
		1	24	19.72	20.02	20
		12	0	18.97	19.3	19.28
		12	6	19	19.34	19.25
		12	13	19.02	19.32	19.26
		25	0	18.86	19.12	19.17
	16QAM	1	0	18.74	19.03	18.95
		1	13	18.62	18.9	18.84
		1	24	18.69	18.98	18.94
		12	0	17.83	18.05	18.1
		12	6	17.86	18.19	18.19
		12	13	17.88	18.14	18.12
		25	0	17.77	17.99	18
Bandwidth	Modulation	RB size	RB offset	Channel	Channel	Channel
				20800	21100	21400
10MHz	QPSK	1	0	20.35	20.41	20.33
		1	25	20.24	20.26	20.18
		1	49	20.22	20.28	20.22
		25	0	19.47	19.56	19.5
		25	13	19.5	19.6	19.47
		25	25	19.52	19.58	19.48
		50	0	19.36	19.38	19.39
	16QAM	1	0	19.24	19.29	19.17
		1	25	19.12	19.16	19.06
		1	49	19.19	19.24	19.16
		25	0	18.33	18.31	18.32
		25	13	18.36	18.45	18.41
		25	25	18.38	18.4	18.34
		50	0	18.27	18.25	18.22



Bandwidth	Modulation	RB size	RB offset	Channel	Channel	Channel
				20825	21100	21375
15MHz	QPSK	1	0	20.45	20.61	20.61
		1	38	20.34	20.46	20.46
		1	74	20.32	20.48	20.5
		36	0	19.57	19.76	19.78
		36	18	19.6	19.8	19.75
		36	39	19.62	19.78	19.76
		75	0	19.46	19.58	19.67
	16QAM	1	0	19.34	19.49	19.45
		1	38	19.22	19.36	19.34
		1	74	19.29	19.44	19.44
		36	0	18.43	18.51	18.6
		36	18	18.46	18.65	18.69
		36	39	18.48	18.6	18.62
		75	0	18.37	18.45	18.5
Bandwidth	Modulation	RB size	RB offset	Channel	Channel	Channel
				20850	21100	21350
20MHz	QPSK	1	0	20.71	20.86	20.78
		1	50	20.6	20.71	20.63
		1	99	20.58	20.73	20.67
		50	0	19.83	20.01	19.95
		50	25	19.86	20.05	19.92
		50	50	19.88	20.03	19.93
		100	0	19.72	19.83	19.84
	16QAM	1	0	19.6	19.74	19.62
		1	50	19.48	19.61	19.51
		1	99	19.55	19.69	19.61
		50	0	18.69	18.76	18.77
		50	25	18.72	18.9	18.86
		50	50	18.74	18.85	18.79
		100	0	18.63	18.7	18.67

5. LTE Band 12 Conducted Power Test Verdict:

LTE FDD Band 12				Conducted Power(dBm)		
Bandwidth	Modulation	RB size	RB offset	Channel	Channel	Channel
				23017	23095	23173
1.4MHz	QPSK	1	0	22.81	22.67	22.78
		1	3	22.69	22.55	22.66
		1	5	22.7	22.56	22.65
		3	0	21.96	21.85	21.96
		3	2	21.99	21.82	21.94
		3	3	21.93	21.86	21.95
		6	0	21.83	21.72	21.81
	16QAM	1	0	21.68	21.52	21.66
		1	3	21.57	21.41	21.53
		1	5	21.66	21.49	21.61
		3	0	20.73	20.57	20.82
		3	2	20.85	20.7	20.93
		3	3	20.84	20.67	20.85
		6	0	20.66	20.54	20.63
Bandwidth	Modulation	RB size	RB offset	Channel	Channel	Channel
				23025	23095	23165
3MHz	QPSK	1	0	22.91	22.85	22.74
		1	7	22.79	22.73	22.62
		1	14	22.8	22.74	22.61
		8	0	22.06	22.03	21.92
		8	4	22.09	22	21.9
		8	7	22.03	22.04	21.91
		15	0	21.93	21.9	21.77
	16QAM	1	0	21.78	21.7	21.62
		1	7	21.67	21.59	21.49
		1	14	21.76	21.67	21.57
		8	0	20.83	20.75	20.78
		8	4	20.95	20.88	20.89
		8	7	20.94	20.85	20.81
		15	0	20.76	20.72	20.59



Bandwidth	Modulation	RB size	RB offset	Channel	Channel	Channel
				23035	23095	23155
5MHz	QPSK	1	0	22.85	22.96	22.91
		1	13	22.73	22.84	22.79
		1	24	22.74	22.85	22.78
		12	0	22	22.14	22.09
		12	6	22.03	22.11	22.07
		12	13	21.97	22.15	22.08
		25	0	21.87	22.01	21.94
	16QAM	1	0	21.72	21.81	21.79
		1	13	21.61	21.7	21.66
		1	24	21.7	21.78	21.74
		12	0	20.77	20.86	20.95
		12	6	20.89	20.99	21.06
		12	13	20.88	20.96	20.98
		25	0	20.7	20.83	20.76
Bandwidth	Modulation	RB size	RB offset	Channel	Channel	Channel
				23060	23095	23130
10MHz	QPSK	1	0	23.05	23.12	23.01
		1	25	22.93	23	22.89
		1	49	22.94	23.01	22.88
		25	0	22.2	22.3	22.19
		25	13	22.23	22.27	22.17
		25	25	22.17	22.31	22.18
		50	0	22.07	22.17	22.04
	16QAM	1	0	21.92	21.97	21.89
		1	25	21.81	21.86	21.76
		1	49	21.9	21.94	21.84
		25	0	20.97	21.02	21.05
		25	13	21.09	21.15	21.16
		25	25	21.08	21.12	21.08
		50	0	20.9	20.99	20.86



6. LTE Band 66 Conducted Power Test Verdict

LTE FDD Band 66				Conducted Power(dBm)		
Bandwidth	Modulation	RB size	RB offset	Channel	Channel	Channel
				131979	132322	132665
1.4MHz	QPSK	1	0	22.15	22.35	22.41
		1	3	22.02	22.25	22.29
		1	5	22.04	22.24	22.28
		3	0	21.32	21.53	21.56
		3	2	21.33	21.52	21.53
		3	3	21.34	21.54	21.54
		6	0	21.2	21.41	21.43
	16QAM	1	0	21.02	21.2	21.3
		1	3	20.87	21.09	21.17
		1	5	21	21.17	21.29
		3	0	20.09	20.28	20.48
		3	2	20.17	20.38	20.51
		3	3	20.19	20.39	20.45
		6	0	20.07	20.29	20.3
Bandwidth	Modulation	RB size	RB offset	Channel	Channel	Channel
				131987	12322	132657
3MHz	QPSK	1	0	22.26	22.41	22.38
		1	7	22.13	22.31	22.26
		1	14	22.15	22.3	22.25
		8	0	21.43	21.59	21.53
		8	4	21.44	21.58	21.5
		8	7	21.45	21.6	21.51
		15	0	21.31	21.47	21.4
	16QAM	1	0	21.13	21.26	21.27
		1	7	20.98	21.15	21.14
		1	14	21.11	21.23	21.26
		8	0	20.2	20.34	20.45
		8	4	20.28	20.44	20.48
		8	7	20.3	20.45	20.42
		15	0	20.18	20.35	20.27



Bandwidth	Modulation	RB size	RB offset	Channel	Channel	Channel
				131997	132322	132647
5MHz	QPSK	1	0	22.38	22.45	22.51
		1	13	22.25	22.35	22.39
		1	24	22.27	22.34	22.38
		12	0	21.55	21.63	21.66
		12	6	21.56	21.62	21.63
		12	13	21.57	21.64	21.64
		25	0	21.43	21.51	21.53
	16QAM	1	0	21.25	21.3	21.4
		1	13	21.1	21.19	21.27
		1	24	21.23	21.27	21.39
		12	0	20.32	20.38	20.58
		12	6	20.4	20.48	20.61
		12	13	20.42	20.49	20.55
		25	0	20.3	20.39	20.4
Bandwidth	Modulation	RB size	RB offset	Channel	Channel	Channel
				132022	132322	132622
10MHz	QPSK	1	0	22.46	22.55	22.69
		1	25	22.33	22.45	22.57
		1	49	22.35	22.44	22.56
		25	0	21.63	21.73	21.84
		25	13	21.64	21.72	21.81
		25	25	21.65	21.74	21.82
		50	0	21.51	21.61	21.71
	16QAM	1	0	21.33	21.4	21.58
		1	25	21.18	21.29	21.45
		1	49	21.31	21.37	21.57
		25	0	20.4	20.48	20.76
		25	13	20.48	20.58	20.79
		25	25	20.5	20.59	20.73
		50	0	20.38	20.49	20.58



Bandwidth	Modulation	RB size	RB offset	Channel	Channel	Channel
				132047	132322	132597
15MHz	QPSK	1	0	22.85	22.91	22.76
		1	38	22.72	22.81	22.64
		1	74	22.74	22.8	22.63
		36	0	22.02	22.09	21.91
		36	18	22.03	22.08	21.88
		36	39	22.04	22.1	21.89
		75	0	21.9	21.97	21.78
	16QAM	1	0	21.72	21.76	21.65
		1	38	21.57	21.65	21.52
		1	74	21.7	21.73	21.64
		36	0	20.79	20.84	20.83
		36	18	20.87	20.94	20.86
		36	39	20.89	20.95	20.8
		75	0	20.77	20.85	20.65
Bandwidth	Modulation	RB size	RB offset	Channel	Channel	Channel
				132072	132322	132572
20MHz	QPSK	1	0	23.15	23.2	23.17
		1	50	23.02	23.1	23.05
		1	99	23.04	23.09	23.04
		50	0	22.32	22.38	22.32
		50	25	22.33	22.37	22.29
		50	50	22.34	22.39	22.3
		100	0	22.2	22.26	22.19
	16QAM	1	0	22.02	22.05	22.06
		1	50	21.87	21.94	21.93
		1	99	22	22.02	22.05
		50	0	21.09	21.13	21.24
		50	25	21.17	21.23	21.27
		50	50	21.19	21.24	21.21
		100	0	21.07	21.14	21.06



7.Band 7 CA

BW (MHz)	Freq (MHz)	Freq (MHz)	Mode	PCC RB	PCC RB	SCC RB	SCC RB	Power (dBm)
				Size	offset	Size	offset	
10+20	2505.5	2519.9	QPSK	1	49	1	0	22.30
				1	24	1	49	14.46
				50	0	100	0	20.89
			16QAM	1	49	1	0	22.09
				1	24	1	49	14.51
				50	0	100	0	19.80
10+20	2525.6	2540.0	QPSK	1	49	1	0	22.40
				1	24	1	49	14.38
				50	0	100	0	20.79
			16QAM	1	49	1	0	22.12
				1	24	1	49	14.47
				50	0	100	0	19.65
10+20	2545.6	2560.0	QPSK	1	49	1	0	22.27
				1	24	1	49	14.39
				50	0	100	0	20.67
			16QAM	1	49	1	0	22.10
				1	24	1	49	14.60
				50	0	100	0	19.74
20+10	2510.0	2524.4	QPSK	1	0	1	0	14.35
				1	0	1	49	14.01
				1	0	50	0	18.65
				1	99	1	49	13.47
				1	99	50	0	19.10
				100	0	1	49	19.24
				100	0	50	0	19.78
				1	99	1	0	22.03
				100	0	1	0	19.74
			16QAM	1	0	1	0	14.49
				1	0	1	49	14.02
				1	0	50	0	18.64
				1	99	1	49	13.78
				1	99	50	0	18.96
				100	0	1	49	19.41
				100	0	50	0	19.63
				1	99	1	0	22.19
				100	0	1	0	19.85



20+10	2530.1	2544.5	QPSK	1	0	1	0	14.69
				1	0	1	49	13.90
				1	0	50	0	18.73
				1	99	1	49	13.85
				1	99	50	0	19.10
				100	0	1	49	19.44
				100	0	50	0	19.86
				1	99	1	0	22.04
			16QAM	100	0	1	0	19.89
				1	0	1	0	14.56
				1	0	1	49	13.89
				1	0	50	0	18.50
				1	99	1	49	13.95
				1	99	50	0	18.98
				100	0	1	49	19.29
				100	0	50	0	19.73
20+10	2550.1	2564.5	QPSK	1	0	1	0	14.57
				1	0	1	49	13.99
				1	0	50	0	18.68
				1	99	1	49	13.75
				1	99	50	0	19.18
				100	0	1	49	19.37
				100	0	50	0	19.88
				1	99	1	0	22.13
			16QAM	100	0	1	0	19.76
				1	0	1	0	14.63
				1	0	1	49	13.95
				1	0	50	0	18.48
				1	99	1	49	13.85
				1	99	50	0	18.79
				100	0	1	49	19.32
				100	0	50	0	19.67
15+20	2507.8	2524.9	QPSK	1	74	1	0	22.04
				1	36	1	49	11.56
				75	0	100	0	19.78
			16QAM	1	74	1	0	21.89
				1	36	1	49	11.31
				75	0	100	0	19.82
15+20	2523.5	2542.4	QPSK	1	74	1	0	22.16
				1	36	1	49	11.46



				75	0	100	0	19.68
			16QAM	1	74	1	0	21.74
				1	36	1	49	11.29
				75	0	100	0	19.88
15+20	2542.9	2560.0	QPSK	1	74	1	0	22.00
				1	36	1	49	11.45
				75	0	100	0	19.67
			16QAM	1	74	1	0	21.84
				1	36	1	49	11.29
				75	0	100	0	19.75
15+15	2507.5	2522.5	QPSK	1	74	1	0	22.28
				75	0	75	0	19.79
			16QAM	1	74	1	0	21.97
				75	0	75	0	19.24
15+15	2527.5	2542.5	QPSK	1	74	1	0	22.21
				75	0	75	0	19.68
			16QAM	1	74	1	0	21.89
				75	0	75	0	19.20
15+15	2547.5	2562.5	QPSK	1	74	1	0	22.26
				75	0	75	0	19.78
			16QAM	1	74	1	0	21.85
				75	0	75	0	19.16
15+10	2507.5	2519.5	QPSK	1	74	1	49	22.06
				1	36	1	24	12.35
				75	0	50	0	19.65
			16QAM	1	74	1	49	21.68
				1	36	1	24	11.47
				75	0	50	0	19.79
15+10	2530.1	2542.1	QPSK	1	74	1	49	22.05
				1	36	1	24	12.28
				75	0	50	0	19.67
			16QAM	1	74	1	49	21.67
				1	36	1	24	11.36
				75	0	50	0	19.68
15+10	2552.7	2564.7	QPSK	1	74	1	49	22.00
				1	36	1	24	12.39
				75	0	50	0	19.64
			16QAM	1	74	1	49	21.70
				1	36	1	24	11.38
				75	0	50	0	19.28
20+15	2510.0	2527.1	QPSK	1	99	1	0	20.19
				100	0	75	0	19.78
			16QAM	1	99	1	0	20.90
				100	0	75	0	19.85



20+15	2527.6	2544.7	QPSK	1	99	1	0	20.08
				100	0	75	0	19.77
			16QAM	1	99	1	0	20.84
				100	0	75	0	19.65
20+15	2545.1	2562.2	QPSK	1	99	1	0	20.10
				100	0	75	0	19.68
			16QAM	1	99	1	0	20.80
				100	0	75	0	19.83
20+20	2510.0	2529.8	QPSK	1	0	1	0	14.72
				1	0	1	99	13.64
				1	0	100	0	19.68
				1	49	1	49	14.21
				1	99	1	99	14.08
				1	99	100	0	20.89
				100	0	1	99	20.29
				100	0	1	99	20.58
				1	99	1	0	22.67
			100	0	1	0	20.9	
			16QAM	1	0	1	0	14.01
				1	0	1	99	13.56
				1	0	100	0	19.36
				1	49	1	49	13.98
				1	99	1	99	14.24
				1	99	100	0	20.74
				100	0	1	99	20.08
				100	0	1	99	20.74
1	99	1		0	22.64			
100	0	1	0	20.86				
20+20	2525.1	2544.9	QPSK	1	0	1	0	14.62
				1	0	1	99	13.59
				1	0	100	0	19.66
				1	49	1	49	14.32
				1	99	1	99	14.10
				1	99	100	0	20.76
				100	0	1	99	20.30
				100	0	1	99	20.51
				1	99	1	0	22.82
			100	0	1	0	20.84	
			16QAM	1	0	1	0	14.00
				1	0	1	99	13.51
				1	0	100	0	19.30
				1	49	1	49	13.84
1	99	1		99	14.26			
1	99	100	0	20.74				



				100	0	1	99	20.09
				100	0	1	99	20.66
				1	99	1	0	22.74
				100	0	1	0	20.79
20+20	2540.2	2560.0	QPSK	1	0	1	0	14.66
				1	0	1	99	13.70
				1	0	100	0	19.54
				1	49	1	49	14.24
				1	99	1	99	14.65
				1	99	100	0	20.79
				100	0	1	99	20.46
				100	0	1	99	20.49
				1	99	1	0	22.79
				100	0	1	0	20.88
			16QAM	1	0	1	0	14.36
				1	0	1	99	13.55
				1	0	100	0	19.49
				1	49	1	49	13.87
				1	99	1	99	14.22
				1	99	100	0	20.69
				100	0	1	99	20.15
				100	0	1	99	20.66
				1	99	1	0	22.57
				100	0	1	0	20.98



7.4 WIFI Conducted Power

WLAN 2.4GHz Band Conducted Power

Channel/Freq.(MHz)	Maximum Conducted Out Power (dBm) Average		
	802.11b	802.11g	802.11n(HT20)
1(2412)	17.80	15.68	15.83
6(2437)	17.87	16.02	15.91
11(2462)	18.18	15.94	16.13
Channel/Freq.(MHz)	Maximum Conducted Out Power (dBm) Average		
	802.11n40		
3(2422)	15.92		
6(2437)	15.50		
9(2452)	15.80		

WLAN 5GHz Band Conducted Power

U-NII-1 AVGSA Output Power		
Mode	Test Frequency (MHz)	Max Conducted Output Power (dBm)
802.11n (20MHz)	5180	14.32
802.11n (20MHz)	5220	13.93
802.11n (20MHz)	5240	14.27
802.11n (40MHz)	5190	11.50
802.11n (40MHz)	5230	13.03
802.11a (20MHz)	5180	13.52
802.11a (20MHz)	5220	11.69
802.11a (20MHz)	5240	13.52
802.11ac (20MHz)	5180	11.42
802.11ac (20MHz)	5220	11.72
802.11ac (20MHz)	5240	14.39
802.11ac (40MHz)	5190	14.79
802.11ac (40MHz)	5230	12.98
802.11ac (80MHz)	5210	14.81



Mode	Test Frequency (MHz)	Max Conducted Output Power (dBm)
802.11a (20MHz)	5745	10.14
802.11a (20MHz)	5785	10.95
802.11a (20MHz)	5825	10.30
802.11n (20MHz)	5745	11.57
802.11n (20MHz)	5785	10.79
802.11n (20MHz)	5825	11.86
802.11n (40MHz)	5755	12.10
802.11n (40MHz)	5795	11.52
802.11ac (20MHz)	5745	11.20
802.11ac (20MHz)	5785	11.47
802.11ac (20MHz)	5825	11.44
802.11ac (40MHz)	5755	14.52
802.11ac (40MHz)	5795	13.86
802.11ac (80MHz)	5775	11.94

Note:

1. Per KDB248227 D01 v02r02, choose the highest output power channel to test SAR and determine further SAR exclusion
2. For each frequency band, testing at higher data rates and higher order modulations is not required when the maximum average output power for each of these configurations is less than 1/4dB higher than those measured at lowest data rate
3. Per KDB248227 D01 v02r02, 802.11g /11n-HT20/11n-HT40 is not required. . When the highest reported SAR for DSSS is adjusted by the ratio of OFDM to DSSS specified maximum output power and the adjusted SAR is $\leq 1.2\text{W/Kg}$. Thus the SAR can be excluded.

7.5 Bluetooth Output Power

Channel	Frequency (MHz)	BT3.0 Output Power(dBm) Average		
		GFSK	$\pi/4$ -DQPSK	8-DPSK
CH 0	2402	9.23	9.17	9.12
CH 39	2441	9.49	9.72	9.64
CH 78	2480	9.55	9.85	9.60
Channel	Frequency (MHz)	BT4.0 Output Power(dBm)Peak		
		GFSK		
CH 0	2402	6.772		
CH 20	2442	6.725		
CH 39	2480	6.979		

8. SAR test Exclusion and estimate SAR calculation:

Note:

- Per KDB 447498 D01v06, the 1-g and 10-g SAR test exclusion thresholds for 100MHz to 6GHz at test separation distances $\leq 50\text{mm}$ are determined by: $[(\text{max. power of channel, including tune-up tolerance, mW}) / (\text{min. test separation distance, mm})] \cdot [\sqrt{f} \text{ (GHz)}] \leq 3.0$ for 1-g SAR and ≤ 7.5 for 10-g extremity SAR
 - f(GHz) is the RF channel transmit frequency in GHz
 - Power and distance are round to the nearest mW and mm before calculation
 - The result is rounded to one decimal place for comparison
 - If the test separation distance(antenna-user) is $< 5\text{mm}$, 5mm is used for excluded SAR calculation

BT4.0 Max Power (dBm)	mW	Test Distance (mm)	Frequency(GHz)	Exclusion Thresholds
7.5	5.623	5	2.45	1.760

Per KDB 447498 D01v06 exclusion thresholds is $1.760 < 3$, RF exposure evaluation is not required.

BT estimated SAR value = $\text{Exclusion Thresholds} / 7.5 = 1.760 / 7.5 = \mathbf{0.235\text{W/Kg}}$

BT4.0 Max Power (dBm)	mW	Test Distance (mm)	Frequency(GHz)	Exclusion Thresholds
7.5	5.623	10	2.45	0.880

Per KDB 447498 D01v06 exclusion thresholds is $0.880 < 3$, RF exposure evaluation is not required.

BT estimated SAR value = $\text{Exclusion Thresholds} / 7.5 = 0.880 / 7.5 = \mathbf{0.117\text{W/Kg}}$

The estimated SAR value is used for simultaneous transmission analysis.

Antenna Location:

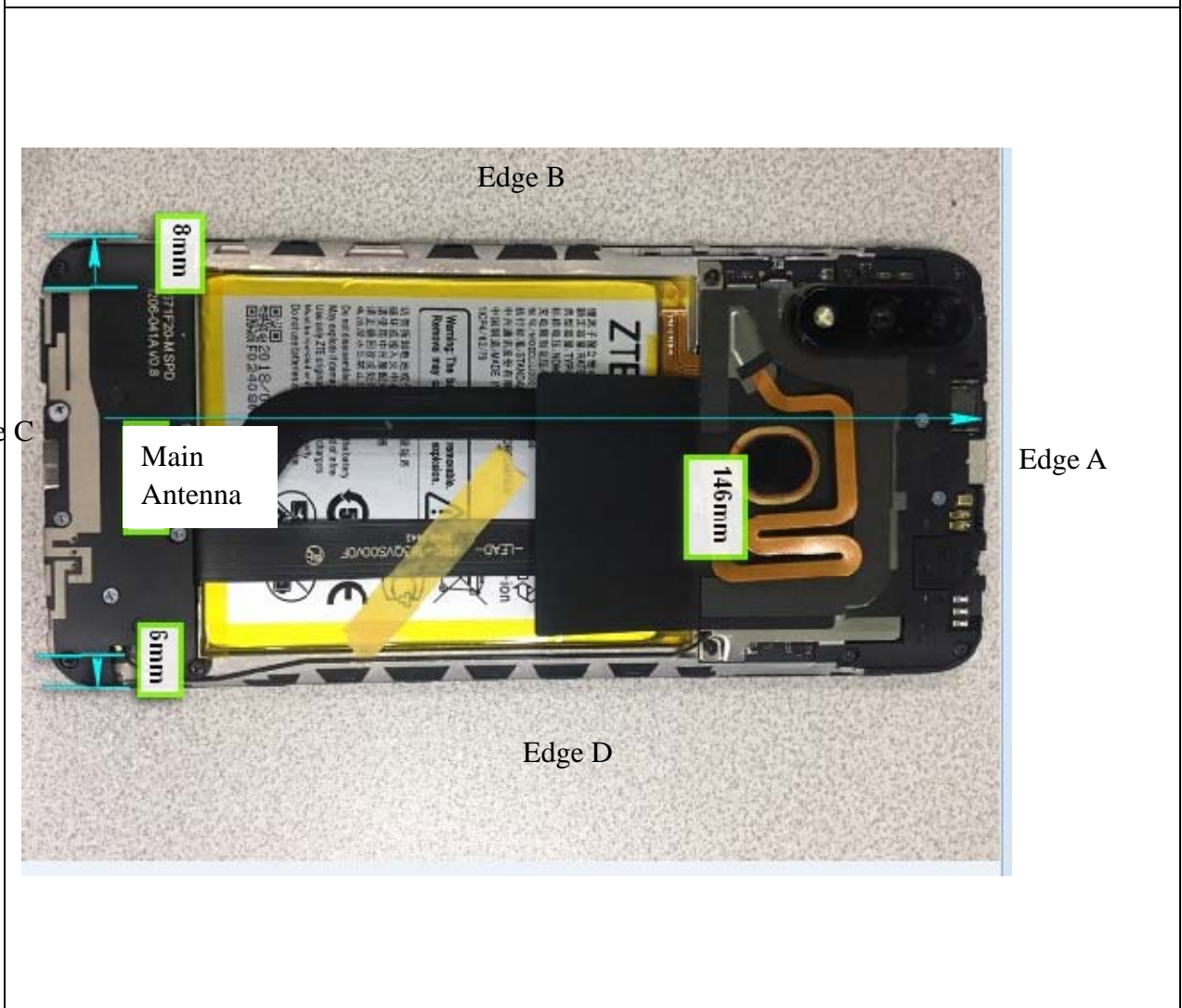
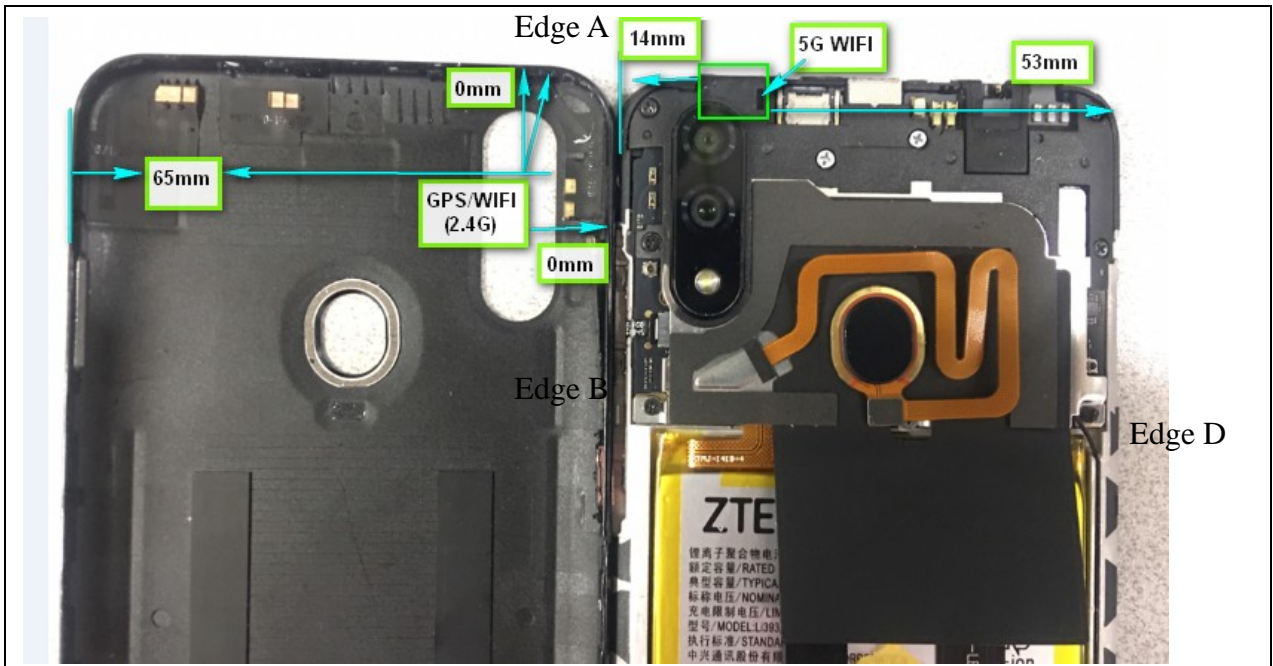



Antenna-to-User (Edge Side) distance (mm):

Antenna	Front	Back	Edge A	Edge B	Edge C	Edge D
WWAN Main Antenna	2	2	146	8	0	6
WIFI2.4G/BT	2	2	0	0	137	65
WIFI 5G	4.5	2	0	14	150	53

Note: The diagonal distance of the overall section is 15.5cm.

The Body SAR measurement positions of each band are as below:

Antenna	Front	Back	Edge A	Edge B	Edge C	Edge D
WWAN Antenna Body-worn	Yes	Yes	No	No	No	No
WWAN Antenna hotspot	Yes	Yes	No	Yes	Yes	Yes
WIFI Antenna Body-worn	Yes	Yes	No	No	No	No
WIFI 2.4G Antenna hotspot	Yes	Yes	Yes	Yes	No	No
WIFI 5G Antenna Body-worn	Yes	Yes	No	No	No	No

Note: According to KDB 941225 D06 v02r01, when antenna-to-edge>2.5cm, SAR is not required.



9. Scaling Factor calculation

Operation Mode	Channel	Output Power(dBm)	Tune up Power in tolerance(dBm)	Scaling Factor
GSM850	128	31.85	31.5 ± 1.0	1.161
	190	32.11	31.5 ± 1.0	1.094
	251	32.09	31.5 ± 1.0	1.099
GPRS850(GPRS) 4Tx	128	26.73	26.0 ± 1.0	1.064
	190	26.85	26.0 ± 1.0	1.035
	251	26.78	26.0 ± 1.0	1.050
GSM1900	512	29.36	29.0 ± 1.0	1.159
	661	29.45	29.0 ± 1.0	1.135
	810	29.62	29.0 ± 1.0	1.091
GPRS1900(GPRS) 4Tx	512	21.56	21.0 ± 1.0	1.107
	661	21.43	21.0 ± 1.0	1.140
	810	21.31	21.0 ± 1.0	1.172
WCDMA850	4132	22.71	22.0 ± 1.0	1.069
	4183	22.84	22.0 ± 1.0	1.038
	4233	22.79	22.0 ± 1.0	1.050
WCDMA1900	9262	22.38	21.5 ± 1.0	1.028
	9400	22.30	21.5 ± 1.0	1.047
	9538	22.19	21.5 ± 1.0	1.074
LTE B2 20MHz 1RB#0	18700	22.41	22.0 ± 1.0	1.146
	18900	22.51	22.0 ± 1.0	1.119
	19100	22.48	22.0 ± 1.0	1.127
LTE B2 20MHz 50RB#0	18700	21.58	21.0 ± 1.0	1.102
	18900	21.69	21.0 ± 1.0	1.074
	19100	21.63	21.0 ± 1.0	1.089
LTE B4 20MHz 1RB#0	20050	22.31	22.0 ± 1.0	1.172
	20175	22.55	22.0 ± 1.0	1.109
	20300	22.45	22.0 ± 1.0	1.135
LTE B4 20MHz 50RB#0	20050	21.48	21.0 ± 1.0	1.127
	20175	21.73	21.0 ± 1.0	1.064
	20300	21.60	21.0 ± 1.0	1.096
LTE B5 10MHz 1RB#0	20450	22.56	22.0 ± 1.0	1.107
	20525	22.66	22.0 ± 1.0	1.081
	20600	22.42	22.0 ± 1.0	1.143
LTE B5 10MHz 25RB#0	20450	21.75	21.0 ± 1.0	1.059
	20525	21.83	21.0 ± 1.0	1.040
	20600	21.59	21.0 ± 1.0	1.099
LTE B7 20MHz 1RB#0	20850	20.71	20.0 ± 1.0	1.069
	21100	20.86	20.0 ± 1.0	1.033
	21350	20.78	20.0 ± 1.0	1.052



LTE B7 20MHz 50RB#0	20850	19.83	19.5 ± 1.0	1.167
	21100	20.01	19.5 ± 1.0	1.119
	21350	19.95	19.5 ± 1.0	1.135
LTE B12 10MHz 1RB#0	23060	23.05	22.5 ± 1.0	1.109
	23095	23.12	22.5 ± 1.0	1.091
	23130	23.01	22.5 ± 1.0	1.119
LTE B12 10MHz 25RB#0	23060	22.20	21.5 ± 1.0	1.072
	23095	22.30	21.5 ± 1.0	1.047
	23130	22.19	21.5 ± 1.0	1.074
LTE B66 20MHz 1RB#0	132072	23.15	22.5 ± 1.0	1.084
	132322	23.20	22.5 ± 1.0	1.072
	132572	23.17	22.5 ± 1.0	1.079
LTE B66 20MHz 50RB#0	132072	22.32	21.5 ± 1.0	1.042
	132322	22.38	21.5 ± 1.0	1.028
	132572	22.32	21.5 ± 1.0	1.042
WIFI 2.4G 802.11b	1	17.80	17.5 ± 1.0	1.552
	6	17.87	17.5 ± 1.0	1.393
	11	18.18	17.5 ± 1.0	1.005
WIFI 5G 802.11ac(80 MHz)	5210	14.81	14.0 ± 1.0	1.045
WIFI 5G 802.11ac (40 MHz)	5755	14.52	14.0 ± 1.0	1.117
BT	CH0	9.17	9.0 ± 1.0	1.211
	CH39	9.72	9.0 ± 1.0	1.067
	CH78	9.85	9.0 ± 1.0	1.035
LTE B7 CA 20MHz+20MHz 1RB#99,1RB#0	Low	22.67	22 ± 1.0	1.079
	Middle	22.82	22 ± 1.0	1.042
	High	22.79	22 ± 1.0	1.050

Note: for LTE power tolerance, only QPSK modulation mode was provide here.

10. Test Results

Table 1: SAR Values of GSM 850MHz Band

Temperature: 23.0~23.5°C, humidity: 62~64%.								
Test Positions			Channel /Frequency (MHz)	SAR(W/Kg), 1.6 (1g average)				Plot No.
				SAR (W/Kg),1g	Scaled Factor	Scaled SAR (W/Kg),1g	Power drift (%)	
Head	Left	Cheek	190/836.6	0.137	1.094	0.150	4.53	--
		Tilt	190/836.6	0.131	1.094	0.143	0.12	--
	Right	Cheek	190/836.6	0.143	1.094	0.156	2.93	1
		Tilt	190/836.6	0.133	1.094	0.146	0.61	--
Body-worn (10mm Separation)	GPRS (4Tx)	Face Upward	190/836.6	0.375	1.035	0.388	-4.28	--
		Back Upward	190/836.6	0.422	1.035	0.437	-0.83	2
Hotspot (10mm Separation)	GPRS (4Tx)	Face Upward	190/836.6	0.375	1.035	0.388	-4.28	--
		Back Upward	190/836.6	0.422	1.035	0.437	-0.83	2
		Edge B	190/836.6	0.125	1.035	0.129	1.11	--
		Edge C	190/836.6	0.251	1.035	0.260	-0.33	--
		Edge D	190/836.6	0.144	1.035	0.149	2.39	--

Table 2: SAR Values of GSM1900 MHz Band

Temperature: 23.0~23.5°C, humidity: 62~64%.								
Test Positions			Channel /Frequency (MHz)	SAR(W/Kg), 1.6 (1g average)				Plot No.
				SAR (W/Kg),1g	Scaled Factor	Scaled SAR (W/Kg),1g	Power drift (%)	
Head	Left	Cheek	661/1880	0.072	1.135	0.082	-4.25	--
		Tilt	661/1880	0.046	1.135	0.052	-0.14	--
	Right	Cheek	661/1880	0.101	1.135	0.115	-3.14	3
		Tilt	661/1880	0.039	1.135	0.044	2.52	--
Body-worn (10mm Separation)	GPRS (4Tx)	Face Upward	661/1880	0.254	1.140	0.290	-3.33	--
		Back Upward	661/1880	0.270	1.140	0.308	-1.26	4
Hotspot (10mm Separation)	GPRS (4Tx)	Face Upward	661/1880	0.254	1.140	0.290	-3.33	--
		Back Upward	661/1880	0.270	1.140	0.308	-1.26	4
		Edge B	661/1880	0.085	1.140	0.097	0.12	--
		Edge C	661/1880	0.170	1.140	0.194	2.36	--
		Edge D	661/1880	0.094	1.140	0.107	3.11	--

Table 3: SAR Values of WCDMA850

Temperature: 23.0~23.5°C, humidity: 62~64%.								
Test Positions			Channel /Frequency (MHz)	SAR(W/Kg), 1.6 (1g average)				Plot No.
				SAR (W/Kg),1g	Scaled Factor	Scaled SAR (W/Kg),1g	Power drift (%)	
Head	Left	Cheek	4183/836.6	0.126	1.038	0.131	0.91	--
		Tilt	4183/836.6	0.076	1.038	0.079	3.19	--
	Right	Cheek	4183/836.6	0.254	1.038	0.264	-1.22	5
		Tilt	4183/836.6	0.241	1.038	0.250	-1.02	--
Body-worn (10mm Separation)		Face Upward	4183/836.6	0.164	1.038	0.170	0.24	--
		Back Upward	4183/836.6	0.293	1.038	0.304	-0.38	6
Hotspot (10mm Separation)		Face Upward	4183/836.6	0.164	1.038	0.170	0.24	--
		Back Upward	4183/836.6	0.293	1.038	0.304	-0.38	6
		Edge B	4183/836.6	0.095	1.038	0.099	-1.23	--
		Edge C	4183/836.6	0.133	1.038	0.138	1.25	--
		Edge D	4183/836.6	0.074	1.038	0.077	3.12	--

Table 4: SAR Values of WCDMA1900

Temperature: 23.0~23.5°C, humidity: 62~64%.								
Test Positions			Channel /Frequency (MHz)	SAR(W/Kg), 1.6 (1g average)				Plot No.
				SAR (W/Kg),1g	Scaled Factor	Scaled SAR (W/Kg),1g	Power drift (%)	
Head	Left	Cheek	9400/1880	0.064	1.047	0.067	-4.64	7
		Tilt	9400/1880	0.035	1.047	0.037	-2.25	--
	Right	Cheek	9400/1880	0.033	1.047	0.035	-1.12	--
		Tilt	9400/1880	0.025	1.047	0.026	1.52	--
Body-worn (10mm Separation)		Face Upward	9400/1880	0.153	1.047	0.160	2.33	--
		Back Upward	9400/1880	0.291	1.047	0.305	-2.71	8
Hotspot (10mm Separation)		Face Upward	9400/1880	0.153	1.047	0.160	2.33	--
		Back Upward	9400/1880	0.291	1.047	0.305	-2.71	8
		Edge B	9400/1880	0.111	1.047	0.116	0.15	--
		Edge C	9400/1880	0.189	1.047	0.198	1.22	--
		Edge D	9400/1880	0.136	1.047	0.142	-2.36	--



Table 5: SAR Values of LTE Band 2,20MHz, QPSK

Temperature: 23.0~23.5°C, humidity: 62~64%.								
Test Positions		Channel /Frequency (MHz)	SAR(W/Kg), 1.6 (1g average)				Plot No.	
			SAR (W/Kg),1g	Scaled Factor	Scaled SAR (W/Kg),1g	Power drift (%)		
1RB #0								
Head	Left	Cheek	18900/1880	0.057	1.119	0.064	3.45	--
		Tilt	18900/1880	0.033	1.119	0.037	0.08	--
	Right	Cheek	18900/1880	0.060	1.119	0.067	-2.35	9
		Tilt	18900/1880	0.041	1.119	0.046	-0.211	--
Body-worn (10mm Separation)	Face Upward		18900/1880	0.015	1.119	0.017	0.37	--
	Back Upward		18900/1880	0.100	1.119	0.112	0.43	10
Hotspot (10mm Separation)	Face Upward		18900/1880	0.015	1.119	0.017	0.37	--
	Back Upward		18900/1880	0.100	1.119	0.112	0.43	10
	Edge B		18900/1880	0.023	1.119	0.026	1.20	--
	Edge C		18900/1880	0.061	1.119	0.068	-0.33	--
	Edge D		18900/1880	0.033	1.119	0.037	-1.25	--
50%RB #0								
Head	Left	Cheek	18900/1880	0.051	1.074	0.055	1.25	--
		Tilt	18900/1880	0.028	1.074	0.030	3.22	--
	Right	Cheek	18900/1880	0.055	1.074	0.059	-2.53	--
		Tilt	18900/1880	0.033	1.074	0.035	-1.33	--
Body-worn (10mm Separation)	Face Upward		18900/1880	0.012	1.074	0.013	1.23	--
	Back Upward		18900/1880	0.085	1.074	0.091	4.11	--
Hotspot (10mm Separation)	Face Upward		18900/1880	0.012	1.074	0.013	1.23	--
	Back Upward		18900/1880	0.085	1.074	0.091	4.11	--
	Edge B		18900/1880	0.021	1.074	0.023	-1.23	--
	Edge C		18900/1880	0.055	1.074	0.059	2.36	--
	Edge D		18900/1880	0.029	1.074	0.031	3.31	--

Table 6: SAR Values of LTE Band 4, 20MHz, QPSK

Temperature: 23.0~23.5°C, humidity: 62~64%.								
Test Positions		Channel /Frequency (MHz)	SAR(W/Kg), 1.6 (1g average)				Plot No.	
			SAR (W/Kg), 1g	Scaled Factor	Scaled SAR (W/Kg), 1g	Power drift (%)		
1RB #0								
Head	Left	Cheek	20175/1732.5	0.055	1.109	0.061	1.23	--
		Tilt	20175/1732.5	0.042	1.109	0.047	2.35	--
	Right	Cheek	20175/1732.5	0.071	1.109	0.079	-1.56	11
		Tilt	20175/1732.5	0.055	1.109	0.061	0.35	--
Body-worn (10mm Separation)	Face Upward		20175/1732.5	0.171	1.109	0.190	-1.11	--
	Back Upward		20175/1732.5	0.224	1.109	0.248	-0.30	12
Hotspot (10mm Separation)	Face Upward		20175/1732.5	0.171	1.109	0.190	-1.11	--
	Back Upward		20175/1732.5	0.224	1.109	0.248	-0.30	12
	Edge B		20175/1732.5	0.095	1.109	0.105	0.36	--
	Edge C		20175/1732.5	0.166	1.109	0.184	0.21	--
	Edge D		20175/1732.5	0.125	1.109	0.139	-1.25	--
50%RB #0								
Head	Left	Cheek	20175/1732.5	0.051	1.064	0.054	2.12	--
		Tilt	20175/1732.5	0.038	1.064	0.040	3.15	--
	Right	Cheek	20175/1732.5	0.066	1.064	0.070	-1.25	--
		Tilt	20175/1732.5	0.043	1.064	0.046	-2.13	--
Body-worn (10mm Separation)	Face Upward		20175/1732.5	0.155	1.064	0.165	2.15	--
	Back Upward		20175/1732.5	0.210	1.064	0.223	0.35	--
Hotspot (10mm Separation)	Face Upward		20175/1732.5	0.155	1.064	0.165	2.15	--
	Back Upward		20175/1732.5	0.210	1.064	0.223	0.35	--
	Edge B		20175/1732.5	0.075	1.064	0.080	-0.33	--
	Edge C		20175/1732.5	0.146	1.064	0.155	1.20	--
	Edge D		20175/1732.5	0.101	1.064	0.107	-2.36	--



Table 7: SAR Values of LTE Band 5,10MHz, QPSK

Temperature: 23.0~23.5°C, humidity: 62~64%.								
Test Positions		Channel /Frequency (MHz)	SAR(W/Kg), 1.6 (1g average)				Plot No.	
			SAR (W/Kg), 1g	Scaled Factor	Scaled SAR (W/Kg), 1g	Power drift (%)		
1RB #0								
Head	Left	Cheek	20525/836.5	0.076	1.081	0.082	-0.28	13
		Tilt	20525/836.5	0.065	1.081	0.070	-0.51	--
	Right	Cheek	20525/836.5	0.071	1.081	0.077	0.49	--
		Tilt	20525/836.5	0.062	1.081	0.067	2.20	--
Body-worn (10mm Separation)	Face Upward		20525/836.5	0.068	1.081	0.074	-0.26	--
	Back Upward		20525/836.5	0.168	1.081	0.182	-0.58	14
Hotspot (10mm Separation)	Face Upward		20525/836.5	0.068	1.081	0.074	-0.26	--
	Back Upward		20525/836.5	0.168	1.081	0.182	-0.58	14
	Edge B		20525/836.5	0.101	1.081	0.109	1.25	--
	Edge C		20525/836.5	0.131	1.081	0.142	-1.33	--
	Edge D		20525/836.5	0.085	1.081	0.092	-0.36	--
50%RB #0								
Head	Left	Cheek	20525/836.5	0.068	1.040	0.071	2.55	--
		Tilt	20525/836.5	0.058	1.040	0.060	1.36	--
	Right	Cheek	20525/836.5	0.068	1.040	0.071	-0.14	--
		Tilt	20525/836.5	0.056	1.040	0.058	-0.55	--
Body-worn (10mm Separation)	Face Upward		20525/836.5	0.055	1.040	0.057	0.13	--
	Back Upward		20525/836.5	0.144	1.040	0.150	1.25	--
Hotspot (10mm Separation)	Face Upward		20525/836.5	0.055	1.040	0.057	0.13	--
	Back Upward		20525/836.5	0.144	1.040	0.150	1.25	--
	Edge B		20525/836.5	0.086	1.040	0.089	-3.25	--
	Edge C		20525/836.5	0.113	1.040	0.118	2.33	--
	Edge D		20525/836.5	0.071	1.040	0.074	1.25	--



Table 8: SAR Values of LTE Band 7,20MHz, QPSK

Temperature: 23.0~23.5°C, humidity: 62~64%.								
Test Positions		Channel /Frequency (MHz)	SAR(W/Kg), 1.6 (1g average)				Plot No.	
			SAR (W/Kg),1g	Scaled Factor	Scaled SAR (W/Kg),1g	Power drift (%)		
1RB #0								
Head	Left	Cheek	21100/2535	0.108	1.033	0.112	-0.24	15
		Tilt	21100/2535	0.068	1.033	0.070	-0.60	--
	Right	Cheek	21100/2535	0.050	1.033	0.052	-1.51	--
		Tilt	21100/2535	0.032	1.033	0.033	-2.57	--
Body-worn (10mm Separation)	Face Upward		21100/2535	0.249	1.033	0.257	0.36	--
	Back Upward		21100/2535	0.686	1.033	0.709	-0.50	16
Hotspot (10mm Separation)	Face Upward		21100/2535	0.249	1.033	0.257	0.36	--
	Back Upward		21100/2535	0.686	1.033	0.709	-0.50	16
	Edge B		21100/2535	0.251	1.033	0.259	1.36	--
	Edge C		21100/2535	0.411	1.033	0.425	2.55	--
	Edge D		21100/2535	0.233	1.033	0.241	-3.65	--
50%RB #0								
Head	Left	Cheek	21100/2535	0.091	1.119	0.102	2.36	--
		Tilt	21100/2535	0.058	1.119	0.065	-1.36	--
	Right	Cheek	21100/2535	0.045	1.119	0.050	-0.55	--
		Tilt	21100/2535	0.026	1.119	0.029	-3.15	--
Body-worn (10mm Separation)	Face Upward		21100/2535	0.211	1.119	0.236	2.33	--
	Back Upward		21100/2535	0.612	1.119	0.685	-1.25	--
Hotspot (10mm Separation)	Face Upward		21100/2535	0.211	1.119	0.236	2.33	--
	Back Upward		21100/2535	0.612	1.119	0.685	-1.25	--
	Edge B		21100/2535	0.234	1.119	0.262	4.12	--
	Edge C		21100/2535	0.368	1.119	0.412	3.14	--
	Edge D		21100/2535	0.213	1.119	0.238	1.30	--

Table 9: SAR Values of LTE Band 12,10MHz, QPSK

Temperature: 23.0~23.5°C, humidity: 62~64%.								
Test Positions		Channel /Frequency (MHz)	SAR(W/Kg), 1.6 (1g average)				Plot No.	
			SAR (W/Kg), 1g	Scaled Factor	Scaled SAR (W/Kg), 1g	Power drift (%)		
1RB #0								
Head	Left	Cheek	23095/707.5	0.091	1.091	0.099	-0.30	--
		Tilt	23095/707.5	0.062	1.091	0.068	-0.85	--
	Right	Cheek	23095/707.5	0.093	1.091	0.101	-1.48	17
		Tilt	23095/707.5	0.088	1.091	0.096	1.23	--
Body-worn (10mm Separation)	Face Upward		23095/707.5	0.091	1.091	0.099	-1.56	--
	Back Upward		23095/707.5	0.318	1.091	0.347	-0.04	18
Hotspot (10mm Separation)	Face Upward		23095/707.5	0.091	1.091	0.099	-1.56	--
	Back Upward		23095/707.5	0.318	1.091	0.347	-0.04	18
	Edge B		23095/707.5	0.123	1.091	0.141	1.33	--
	Edge C		23095/707.5	0.211	1.091	0.230	2.25	--
	Edge D		23095/707.5	0.134	1.091	0.146	-0.23	--
50%RB #0								
Head	Left	Cheek	23095/707.5	0.085	1.047	0.089	-3.25	--
		Tilt	23095/707.5	0.057	1.047	0.060	-4.15	--
	Right	Cheek	23095/707.5	0.081	1.047	0.085	-2.33	--
		Tilt	23095/707.5	0.076	1.047	0.080	-1.22	--
Body-worn (10mm Separation)	Face Upward		23095/707.5	0.085	1.047	0.089	2.85	--
	Back Upward		23095/707.5	0.256	1.047	0.268	3.63	--
Hotspot (10mm Separation)	Face Upward		23095/707.5	0.085	1.047	0.089	2.85	--
	Back Upward		23095/707.5	0.256	1.047	0.268	3.63	--
	Edge B		23095/707.5	0.101	1.047	0.106	1.36	--
	Edge C		23095/707.5	0.188	1.047	0.197	2.15	--
	Edge D		23095/707.5	0.132	1.047	0.138	2.33	--



Table 10: SAR Values of LTE Band 66,20MHz, QPSK

Temperature: 23.0~23.5°C, humidity: 62~64%.								
Test Positions		Channel /Frequency (MHz)	SAR(W/Kg), 1.6 (1g average)				Plot No.	
			SAR (W/Kg), 1g	Scaled Factor	Scaled SAR (W/Kg), 1g	Power drift (%)		
1RB #0								
Head	Left	Cheek	131979/1710.7	0.143	1.072	0.153	0.64	19
		Tilt	131979/1710.7	0.129	1.072	0.138	0.88	--
	Right	Cheek	131979/1710.7	0.076	1.072	0.081	0.84	--
		Tilt	131979/1710.7	0.075	1.072	0.080	-0.26	--
Body-worn (10mm Separation)	Face Upward		131979/1710.7	0.368	1.072	0.394	-1.03	--
	Back Upward		131979/1710.7	0.476	1.072	0.510	-0.79	20
Hotspot (10mm Separation)	Face Upward		131979/1710.7	0.368	1.072	0.394	-1.03	--
	Back Upward		131979/1710.7	0.476	1.072	0.510	-0.79	20
	Edge B		131979/1710.7	0.095	1.072	0.102	-0.49	--
	Edge C		131979/1710.7	0.225	1.072	0.241	-0.05	--
	Edge D		131979/1710.7	0.051	1.072	0.055	0.81	--
50%RB #0								
Head	Left	Cheek	131979/1710.7	0.133	1.028	0.137	3.15	--
		Tilt	131979/1710.7	0.121	1.028	0.124	1.22	--
	Right	Cheek	131979/1710.7	0.071	1.028	0.073	2.35	--
		Tilt	131979/1710.7	0.063	1.028	0.065	-1.32	--
Body-worn (10mm Separation)	Face Upward		131979/1710.7	0.345	1.028	0.355	-2.64	--
	Back Upward		131979/1710.7	0.452	1.028	0.465	2.55	--
Hotspot (10mm Separation)	Face Upward		131979/1710.7	0.345	1.028	0.355	-2.64	--
	Back Upward		131979/1710.7	0.452	1.028	0.465	2.55	--
	Edge B		131979/1710.7	0.088	1.028	0.090	0.15	--
	Edge C		131979/1710.7	0.203	1.028	0.209	1.78	--
	Edge D		131979/1710.7	0.043	1.028	0.044	-3.46	--

Table 11: SAR Values of Wi-Fi 802.11b

Temperature: 23.0~23.5°C, humidity: 62~64%.								
Test Positions			Channel /Frequency (MHz)	SAR(W/Kg), 1.6 (1g average)				Plot No.
				SAR (W/Kg),1g	Scaled Factor	Scaled SAR (W/Kg),1g	Power drift (%)	
Head	Left	Cheek	6/2437	0.195	1.393	0.272	0.15	--
		Tilt	6/2437	0.212	1.393	0.295	0.51	--
	Right	Cheek	6/2437	0.383	1.393	0.534	-0.77	21
		Tilt	6/2437	0.334	1.393	0.465	-1.33	--
Body-worn (10mm Separation)	Face Upward		6/2437	6/2437	1.393	0.116	-2.33	--
	Back Upward		6/2437	6/2437	1.393	0.203	-1.71	22
Hotspot (10mm Separation)	Face Upward		6/2437	6/2437	1.393	0.116	-2.33	--
	Back Upward		6/2437	6/2437	1.393	0.203	-1.71	22
	Edge A		6/2437	6/2437	1.393	0.113	-1.52	--
	Edge B		6/2437	6/2437	1.393	0.045	3.15	--

Table 12: SAR Values of 5.2GHz Wi-Fi 802.11ac 80MHz

Temperature: 23.0~23.5°C, humidity: 62~64%.								
Test Positions			Channel /Frequency (MHz)	SAR(W/Kg), 1.6 (1g average)				Plot No.
				SAR (W/Kg),1g	Scaled Factor	Scaled SAR (W/Kg),1g	Power drift (%)	
Head	Left	Cheek	5210	0.500	1.045	0.523	-3.42	23
		Tilt	5210	0.482	1.045	0.504	-1.23	--
	Right	Cheek	5210	0.209	1.045	0.218	-3.29	--
		Tilt	5210	0.169	1.045	0.177	-4.20	--
Body-worn (10mm Separation)	Face Upward		5210	0.091	1.045	0.095	-4.21	--
	Back Upward		5210	0.155	1.045	0.162	-3.06	24

Table 13: SAR Values of 5.8GHz Wi-Fi 802.11ac 40MHz

Temperature: 23.0~23.5°C, humidity: 62~64%.								
Test Positions			Channel /Frequency (MHz)	SAR(W/Kg), 1.6 (1g average)				Plot No.
				SAR (W/Kg),1g	Scaled Factor	Scaled SAR (W/Kg),1g	Power drift (%)	
Head	Left	Cheek	5755	0.308	1.117	0.344	-2.60	25
		Tilt	5755	0.292	1.117	0.326	0.33	--
	Right	Cheek	5755	0.193	1.117	0.215	-2.56	--
		Tilt	5755	0.155	1.117	0.173	-1.10	--
Body-worn (10mm Separation)	Face Upward		5755	0.082	1.117	0.091	1.21	--
	Back Upward		5755	0.134	1.117	0.150	3.92	26

 Table 14: SAR Values of BT3.0 π /4-DQPSK

Temperature: 23.0~23.5°C, humidity: 62~64%.								
Test Positions			Channel	SAR(W/Kg), 1.6 (1g average)				Plot No.
				SAR (W/Kg),1g	Scaled Factor	Scaled SAR (W/Kg),1g	Power drift (%)	
Head	Left	Cheek	CH78	0.020	1.035	0.021	0.35	--
		Tilt	CH78	0.022	1.035	0.023	-0.63	27
	Right	Cheek	CH78	0.011	1.035	0.011	1.93	---
		Tilt	CH78	0.012	1.035	0.012	1.38	--
Body-worn (10mm Separation)	Face Upward		CH78	0.005	1.035	0.005	-0.05	--
	Back Upward		CH78	0.011	1.035	0.011	-0.15	28

Table 15: SAR Values of LTE Band 7, CA, 20MHz+20MHz, QPSK

Temperature: 23.0~23.5°C, humidity: 62~64%.								
Test Positions		Channel /Frequency (MHz)	SAR(W/Kg), 1.6 (1g average)				Plot No.	
			SAR (W/Kg), 1g	Scaled Factor	Scaled SAR (W/Kg), 1g	Power drift (%)		
1RB #99, 1RB#0								
Head	Left	Cheek	Middle	0.066	1.042	0.069	-0.56	--
		Tilt	Middle	0.033	1.042	0.034	-0.09	--
	Right	Cheek	Middle	0.035	1.042	0.036	-0.04	--
		Tilt	Middle	0.028	1.042	0.029	-1.00	--
Body-worn (10mm Separation)	Face Upward		Middle	0.226	1.042	0.235	1.14	--
	Back Upward		Middle	0.616	1.042	0.642	0.12	--
Hotspot (10mm Separation)	Face Upward		Middle	0.226	1.042	0.235	1.14	--
	Back Upward		Middle	0.616	1.042	0.642	0.12	--
	Edge B		Middle	0.017	1.042	0.018	2.99	--
	Edge C		Middle	0.420	1.042	0.438	0.09	--
	Edge D		Middle	0.077	1.042	0.080	-0.25	--

Note:

Per KDB941225 D06 v02r01, When the antenna-to-edge distance is greater than 2.5cm, such position does not need to be tested. As the manufacture requirement the separation distance use 5mm for Hotspot mode.

Per KDB Publication 941225 D01v03r01. RMC 12.2kbps was as primary mode SAR, when the primary mode SAR less than 1.2W/kg, secondary SAR (HSPA) was not requires.

When the 1-g SAR for the mid-band channel or the channel with the highest output power satisfy the following conditions, testing of the other channels in the band is not required. (Per KDB 447498 D01 General RF Exposure Guidance v06)

- ≤ 0.8 W/kg, when the transmission band is ≤ 100 MHz
- ≤ 0.6 W/kg, when the transmission band is between 100 MHz and 200 MHz
- ≤ 0.4 W/kg, when the transmission band is ≥ 200 MHz

11. Simultaneous Transmissions Analysis

Localized Specific Absorption Rate (SAR) of this portable wireless device has been measured in all cases requested by the relevant standards cited in Clause 6 of this report. Maximum localized SAR is **below** exposure limits specified in the relevant standards.

Simultaneous SAR

No.	Transmitter Combinations	Scenario Supported or not	Supported for Mobile Hotspot or not
1	GSM + BT	Yes	No
2	GSM + WIFI 2.4G	Yes	Yes
3	WCDMA +BT	Yes	No
4	WCDMA +WIFI2.4G	Yes	Yes
5	LTE+BT	Yes	No
6	LTE+WIFI 2.4G	Yes	Yes
7	WIFI+BT	No	No
8	GSM/WCDMA/LTE+WIFI 5G	Yes	No

Simultaneous Tx Combination of GSM/CDMA/WCDMA/LTE and BT/WIFI (Head)

Test Position		Left Cheek	Left Tilt	Right Cheek	Right Tilt
Head MAX 1-g SAR(W/Kg)	GPRS850	0.150	0.143	0.156	0.146
	GPRS1900	0.082	0.052	0.115	0.044
	WCDMA 850	0.131	0.079	0.264	0.250
	WCDMA 1900	0.067	0.037	0.035	0.026
	LTE Band2	0.064	0.037	0.067	0.046
	LTE Band4	0.061	0.047	0.079	0.061
	LTE Band5	0.082	0.070	0.077	0.067
	LTE Band7	0.112	0.070	0.052	0.033
	LTE Band12	0.099	0.068	0.101	0.096
	LTE Band66	0.153	0.138	0.081	0.080
	WIFI 802.11b	0.272	0.295	0.534	0.465
	WIFI 802.11ac	0.523	0.504	0.218	0.177
	BT	0.021	0.023	0.011	0.012
WIFI Simultaneous Σ 1-g SAR(W/Kg)		0.703	0.647	0.798	0.715
BT Simultaneous Σ 1-g SAR(W/Kg)		0.201	0.166	0.375	0.262



Simultaneous Tx Combination of GSM/CDMA/WCDMA/LTE and BT/WIFI (Body).

Test Position		Face	Back	Edge A	Edge B	Edge C	Edge D
Body-worn 10mm separation MAX 1-g SAR(W/Kg)	GPRS850	0.388	0.437	/	/	/	/
	GPRS1900	0.290	0.308	/	/	/	/
	WCDMA 850	0.170	0.304	/	/	/	/
	WCDMA 1900	0.160	0.305	/	/	/	/
	LTE Band2	0.017	0.112	/	/	/	/
	LTE Band4	0.190	0.248	/	/	/	/
	LTE Band5	0.074	0.182	/	/	/	/
	LTE Band7	0.257	0.709	/	/	/	/
	LTE Band12	0.099	0.347	/	/	/	/
	LTE Band66	0.394	0.510	/	/	/	/
	WIFI 802.11b	0.116	0.203	/	/	/	/
	WIFI 802.11ac	0.095	0.162	/	/	/	/
	BT	0.005	0.011	/	/	/	/
WIFI Simultaneous Σ 1-g SAR(W/Kg)		0.510	0.912	/	/	/	/
BT Simultaneous Σ 1-g SAR(W/Kg)		0.399	0.720	/	/	/	/

Simultaneous Tx Combination of GSM/CDMA/WCDMA/LTE and WIFI (Body).

Test Position		Face	Back	Edge A	Edge B	Edge C	Edge D
Hotspot 10mm separation MAX 1-g SAR(W/Kg)	GPRS850	0.388	0.437	/	0.129	0.260	0.149
	GPRS1900	0.290	0.308	/	0.097	0.194	0.107
	WCDMA 850	0.170	0.304	/	0.099	0.138	0.077
	WCDMA 1900	0.160	0.305	/	0.116	0.198	0.142
	LTE Band2	0.017	0.112	/	0.026	0.068	0.037
	LTE Band4	0.190	0.248	/	0.105	0.184	0.139
	LTE Band5	0.074	0.182	/	0.109	0.142	0.092
	LTE Band7	0.257	0.709	/	0.259	0.425	0.241
	LTE Band12	0.099	0.347	/	0.141	0.230	0.146
	LTE Band66	0.394	0.510	/	0.102	0.241	0.055
WIFI 802.11b	0.116	0.203	0.113	0.045	/	/	
WIFI Simultaneous Σ 1-g SAR(W/Kg)		0.510	0.912	0.113	0.304	0.425	0.3
BT Simultaneous Σ 1-g SAR(W/Kg)		0.399	0.720	/	0.259	0.542	0.241

The estimated SAR value with * Signal

SAR to Peak Location Separation Ratio (SPLSR)

As the Sum of the SAR is not greater than 1.6 W/kg SPLSR assessment is not required

12. Measurement Uncertainty

No.	Uncertainty Component	Type	Uncertainty Value (%)	Probability Distribution	k	ci	Standard Uncertainty (%) $u_i(\%)$	Degree of freedom ν_{eff} or ν_i
Measurement System								
1	- Probe Calibration	B	5.8	N	1	1	5.8	∞
2	- Axial isotropy	B	3.5	R	$\sqrt{3}$	0.5	1.43	∞
3	- Hemispherical Isotropy	B	5.9	R	$\sqrt{3}$	0.5	2.41	∞
4	- Boundary Effect	B	1	R	$\sqrt{3}$	1	0.58	∞
5	- Linearity	B	4.7	R	$\sqrt{3}$	1	2.71	∞
6	- System Detection Limits	B	1.0	R	$\sqrt{3}$	1	0.58	∞
7	Modulation response	B	3	N	1	1	3.00	
8	- Readout Electronics	B	0.5	N	1	1	0.50	∞
9	- Response Time	B	1.4	R	$\sqrt{3}$	1	0.81	∞
10	- Integration Time	B	3.0	R	$\sqrt{3}$	1	1.73	∞
11	- RF Ambient Conditions	B	3.0	R	$\sqrt{3}$	1	1.73	∞
12	- Probe Position Mechanical tolerance	B	1.4	R	$\sqrt{3}$	1	0.81	∞
13	- Probe Position with respect to Phantom Shell	B	1.4	R	$\sqrt{3}$	1	0.81	∞
14	- Extrapolation, Interpolation and Integration Algorithms for Max. SAR evaluation	B	2.3	R	$\sqrt{3}$	1	1.33	∞

Uncertainties of the DUT								
15	- Position of the DUT	A	2.6	N	$\sqrt{3}$	1	2.6	5
16	- Holder of the DUT	A	3	N	$\sqrt{3}$	1	3.0	5
17	- Output Power Variation -SAR drift measurement	B	5.0	R	$\sqrt{3}$	1	2.89	∞
Phantom and Tissue Parameters								
18	- Phantom Uncertainty(shape and thickness tolerances)	B	4	R	$\sqrt{3}$	1	2.31	∞
19	Uncertainty in SAR correction for deviation(in permittivity and conductivity)	B	2	N	1	1	2.00	
20	- Liquid Conductivity Target -tolerance	B	2.5	R	$\sqrt{3}$	0.6	1.95	∞
21	- Liquid Conductivity -measurement Uncertainty)	B	4	N	$\sqrt{3}$	1	0.92	9
22	- Liquid Permittivity Target tolerance	B	2.5	R	$\sqrt{3}$	0.6	1.95	∞
23	- Liquid Permittivity -measurement uncertainty	B	5	N	$\sqrt{3}$	1	1.15	∞
Combined Standard Uncertainty				RSS			10.63	
Expanded uncertainty (Confidence interval of 95 %)				K=2			21.26	

System Check Uncertainty

No.	Uncertainty Component	Type	Uncertainty Value (%)	Probability Distribution	k	ci	Standard Uncertainty (%) $u_i(\%)$	Degree of freedom V_{eff} or v_i
Measurement System								
1	- Probe Calibration	B	5.8	N	1	1	5.8	∞



2	- Axial isotropy	B	3.5	R	$\sqrt{3}$	0.5	1.43	∞
3	- Hemispherical Isotropy	B	5.9	R	$\sqrt{3}$	0.5	2.41	∞
4	- Boundary Effect	B	1	R	$\sqrt{3}$	1	0.58	∞
5	- Linearity	B	4.7	R	$\sqrt{3}$	1	2.71	∞
6	- System Detection Limits	B	1	R	$\sqrt{3}$	1	0.58	∞
7	Modulation response	B	0	N	1	1	0.00	
8	- Readout Electronics	B	0.5	N	1	1	0.50	∞
9	- Response Time	B	0.00	R	$\sqrt{3}$	1	0.00	∞
10	- Integration Time	B	1.4	R	$\sqrt{3}$	1	0.81	∞
11	- RF Ambient Conditions	B	3.0	R	$\sqrt{3}$	1	1.73	∞
12	- Probe Position Mechanical tolerance	B	1.4	R	$\sqrt{3}$	1	0.81	∞
13	- Probe Position with respect to Phantom Shell	B	1.4	R	$\sqrt{3}$	1	0.81	∞
14	- Extrapolation, Interpolation and Integration Algorithms for Max. SAR evaluation	B	2.3	R	$\sqrt{3}$	1	1.33	∞
Uncertainties of the DUT								
15	Deviation of experimental source from numerical source	A	4	N	1	1	4.00	5
16	Input Power and SAR drift measurement	A	5	R	$\sqrt{3}$	1	2.89	5
17	Dipole Axis to Liquid Distance	B	2	R	$\sqrt{3}$	1	1.2	∞

Phantom and Tissue Parameters								
18	- Phantom Uncertainty(shape and thickness tolerances)	B	4	R	$\sqrt{3}$	1	2.31	∞
19	Uncertainty in SAR correction for deviation(in permittivity and conductivity)	B	2	N	1	1	2.00	
20	- Liquid Conductivity Target -tolerance	B	2.5	R	$\sqrt{3}$	0.6	1.95	∞
21	- Liquid Conductivity -measurement Uncertainty)	B	4	N	$\sqrt{3}$	1	0.92	9
22	- Liquid Permittivity Target tolerance	B	2.5	R	$\sqrt{3}$	0.6	1.95	∞
23	- Liquid Permittivity -measurement uncertainty	B	5	N	$\sqrt{3}$	1	1.15	∞
Combined Standard Uncertainty				RSS			10.15	
Expanded uncertainty (Confidence interval of 95 %)				K=2			20.29	



13. Equipment List

This table is a complete overview of the SAR measurement equipment. Devices used during the test described are marked .

	EQUIPMENT	Model	Serial number	Calibration Date	Due Date
<input checked="" type="checkbox"/>	SAR Probe	SSE5	SN 04/13 EP166	2018/04/01	2019/03/31
<input type="checkbox"/>	Dipole	SID750	SN 23/15 DIP0G750-378	2017/11/27	2019/11/26
<input checked="" type="checkbox"/>	Dipole	SID835	SN 09/13 DIP0G835-217	2017/11/27	2019/11/26
<input checked="" type="checkbox"/>	Dipole	SID1800	SN 09/13 DIP1G800-216	2017/11/27	2019/11/26
<input checked="" type="checkbox"/>	Dipole	SID1900	SN 09/13 DIP1G900-218	2017/11/27	2019/11/26
<input checked="" type="checkbox"/>	Dipole	SID2450	SN_09/13_DIP2G450-220	2017/11/27	2019/11/26
<input checked="" type="checkbox"/>	Dipole	SID2600	SN 32/14_DIP2G600-338	2017/11/27	2019/11/26
<input checked="" type="checkbox"/>	SAR Probe	SSE2	SN27/15 EPGO261	2018/11/20	2019/11/19
<input checked="" type="checkbox"/>	Dipole	SWG5500	SN15/15 WGA39	2017/11/27	2019/11/26
<input checked="" type="checkbox"/>	Multimeter	Keithley-2000	4085310	2018/09/06	2019/09/05
<input checked="" type="checkbox"/>	System Simulator(Agilent 8960)	E5515C	GB 47200710	2017/11/08	2019/11/07
<input checked="" type="checkbox"/>	System Simulator(R&S)	CMW500	130805	2017/08/29	2019/08/28
<input checked="" type="checkbox"/>	KEYSIGHT	E7515A	MY56040357	2018/04/18	2019/04/18
<input checked="" type="checkbox"/>	Vector Network Analyzer(R&S)	ZVB8	A0802530	2018/05/09	2019/05/09
<input checked="" type="checkbox"/>	PC 3.5 Fixed Match Calibration Kit	ZV-Z32	100571	2017/11/29	2019/11/28
<input checked="" type="checkbox"/>	Dielectric Probe Kit	SCLMP	SN 09/13 OCPG51	2017/11/27	2019/11/26
<input checked="" type="checkbox"/>	Signal Generator	SMU200A	A140801889	2018/05/09	2019/05/09
<input checked="" type="checkbox"/>	Amplifier	Nucletudes	143060	2018/03/27	2019/03/28
<input checked="" type="checkbox"/>	Directional Coupler	DC6180A	305827	2018/03/27	2019/03/28
<input checked="" type="checkbox"/>	Power Meter	NRP2	A140401673	2018/03/27	2019/03/28
<input checked="" type="checkbox"/>	Power Sensor	NPR-Z11	1138.3004.02-114072-nq	2018/03/27	2019/03/28
<input checked="" type="checkbox"/>	Power Meter	NRVS	A0802531	2018/03/27	2019/03/28
<input checked="" type="checkbox"/>	Power Sensor	NRV-Z4	100069	2018/03/27	2019/03/28



ANNEX A: Appendix A: SAR System performance Check Plots

(Please See Appendix A)

ANNEX B: Appendix B: SAR Measurement results Plots

(Please See Appendix B)

ANNEX C: Appendix C: Calibration reports

(Please See Appendix C)

ANNEX D: Appendix D: SAR Test Setup

(Please See Appendix D)

—End of the Report—