



EMC TEST REPORT

Applicant ZTE Corporation
FCC ID SRQ-A31PLUS2
Product LTE/WCDMA/GSM(GPRS)
Multi-Mode Digital Mobile Phone
Model ZTE Blade A31 Plus
Report No. ~~AMUGGEI E-HJ~~ E1
Issue Date June 9, 2022

TA Technology (Shanghai) Co., Ltd. tested the above equipment in accordance with the requirements in **FCC Code CFR47 Part15B (2021)/ ANSI C63.4 (2014)**. The test results show that the equipment tested is capable of demonstrating compliance with the requirements as documented in this report.

Wei Liu
Prepared by: Wei Liu

Guangchang Fan
Approved by: Guangchang Fan

TA Technology (Shanghai) Co., Ltd.

No.145, Jintang Rd, Tangzhen Industry Park, Pudong Shanghai, China

TEL: +86-021-50791141/2/3

FAX: +86-021-50791141/2/3-8000

Table of Contents

1	Test Laboratory.....	4
1.1	Notes of the Test Report.....	4
1.2	Test facility.....	4
1.3	Testing Location.....	4
2	General Description of Equipment under Test.....	5
2.1	Applicant and Manufacturer Information.....	5
2.2	General information.....	5
2.3	Applied Standards.....	7
2.4	Test Mode.....	8
3	Test Case Results.....	9
3.1	Radiated Emission.....	9
3.2	Conducted Emission.....	14
4	Main Test Instruments.....	17
	ANNEX A: The EUT Appearance.....	18
	ANNEX B: Test Setup Photos.....	19
	ANNEX C: Product Change Description (Variant 1).....	20
	ANNEX D: Product Change Description (Variant 2).....	21

Summary of measurement results

Number	Test Case	Clause in FCC Rules	Conclusion
1	Radiated Emission	FCC Part15.109, ANSI C63.4-2014	PASS
2	Conducted Emission	FCC Part15.107, ANSI C63.4-2014	PASS
Date of Testing: (Original) August 8, 2021 ~ August 29, 2021 (Variant) November 15, 2021 Date of Sample Received: August 1, 2021			
Note: All indications of Pass/Fail in this report are opinions expressed by TA Technology (Shanghai) Co., Ltd. based on interpretations and/or observations of test results. Measurement Uncertainties were not taken into account and are published for informational purposes only.			

ZTE Blade A31 Plus (Report No.: R2205A0397-E1) is a variant model (Variant 2) of ZTE Blade A31 Plus (Report No.: R2110A0943-E1). There is only tested Radiated Emission, and did not worsen, so they were not recorded in the report. The detailed product change description please refers to the Difference Declaration Letter.

ZTE Blade A31 Plus (Report No.: R2110A0943-E1) is a variant model (Variant 1) of ZTE Blade A31 Plus (Report No.: R2108A0671-E1). This product is only added LTE Band 12/17, changed Software Version and changed to dual card slots. There is only tested Radiated Emission, and Radiated Emission was worsen, so they were recorded in the report. The detailed product change description please refers to the Difference Declaration Letter.

1 Test Laboratory

1.1 Notes of the Test Report

This report shall not be reproduced in full or partial, without the written approval of **TA technology (shanghai) co., Ltd.** The results documented in this report apply only to the tested sample, under the conditions and modes of operation as described herein. Measurement Uncertainties were not taken into account and are published for informational purposes only. This report is written to support regulatory compliance of the applicable standards stated above.

1.2 Test facility

FCC (Designation number: CN1179, Test Firm Registration Number: 446626)

TA Technology (Shanghai) Co., Ltd. has been listed on the US Federal Communications Commission list of test facilities recognized to perform measurements.

A2LA (Certificate Number: 3857.01)

TA Technology (Shanghai) Co., Ltd. has been listed by American Association for Laboratory Accreditation to perform measurement.

1.3 Testing Location

Company: TA Technology (Shanghai) Co., Ltd.
Address: No.145, Jintang Rd, Tangzhen Industry Park, Pudong Shanghai, China
City: Shanghai
Post code: 201201
Country: P. R. China
Contact: Fan Guangchang
Telephone: +86-021-50791141/2/3
Fax: +86-021-50791141/2/3-8000
Website: <http://www.ta-shanghai.com>
E-mail: fanguangchang@ta-shanghai.com

2 General Description of Equipment under Test

2.1 Applicant and Manufacturer Information

Applicant	ZTE Corporation
Applicant address	ZTE Plaza, #55 Keji Road South, Hi-Tech Industrial Park, Nanshan District, Shenzhen, China
Manufacturer	ZTE Corporation
Manufacturer address	ZTE Plaza, #55 Keji Road South, Hi-Tech Industrial Park, Nanshan District, Shenzhen, China

2.2 General information

EUT Description			
Device Type	Portable Device		
Model	ZTE Blade A31 Plus		
IMEI	IMEI 1: 866591060000396 IMEI 2: 866591060001543		
HW Version	z1kA		
SW Version	GEN_LA_A31_Plus_V1.0		
Power Rating	DC 5V from Adapter.		
Connecting I/O Port(s)	Please refer to the User's Manual.		
Antenna Type	Internal Antenna		
Frequency	Band	Tx (MHz)	Rx (MHz)
	GSM 850	824 ~ 849	869 ~ 894
	GSM 1900	1850 ~ 1910	1930 ~ 1990
	WCDMA Band II	1850 ~ 1910	1930 ~ 1990
	WCDMA Band IV	1710 ~ 1755	2110 ~ 2155
	WCDMA Band V	824 ~ 849	869 ~ 894
	LTE Band 2	1850 ~ 1910	1930 ~ 1990
	LTE Band 4	1710 ~ 1755	2110 ~ 2155
	LTE Band 5	824 ~ 849	869 ~ 894
	LTE Band 7	2500 ~ 2570	2620 ~ 2690
	LTE Band 12	699 ~ 716	729 ~ 746
	LTE Band 13	777 ~ 787	746 ~ 756
	LTE Band 17	704 ~ 716	734 ~ 746
	LTE Band 38	2570 ~ 2620	2570 ~ 2620



	LTE Band 66	1710 ~ 1780	2110 ~ 2200
	Bluetooth	2400 ~ 2483.5	2400 ~ 2483.5
	WIFI 2.4G	2400 ~ 2483.5	2400 ~ 2483.5
EUT Accessory			
Adapter 1	Manufacturer: Shenzhen Ruijing Industrial Co.,Ltd Model: STC-A51D-Z Input: 100-240V~50/60Hz 250mA Output: 5.0V $\overline{\text{---}}$ 1000mA		
Adapter 2	Manufacturer: HUIZHOU PUAN ELECTRONICS CO.,LTD Model: STC-A51D-Z Input: 100-240V~50/60Hz 250mA Output: 5.0V $\overline{\text{---}}$ 1000mA		
Battery	Manufacturer: Guangdong Fenghua New Energy Co.,Ltd. Model: Li3830T43P8h486375 DC 3.8V, 3000mAh, 11.4Wh		
Earphone 1	Manufacturer: Shenzhen FDC Electronics Co. ,Ltd. Model: DEM-8A		
Earphone 2	Manufacturer: JUWEI ELECTRONICS CO., LTD Model: JWEP1091-Z01		
USB Cable 1	Manufacturer: Dongguan Guojun Plastic Electronic Co.,Ltd Model: USB-MU5-B-70-M-L		
USB Cable 2	Manufacturer: Shenzhen Yihuaxing Electronic Co., Ltd. Model: USB-MU5-B-70-M-L		
Auxiliary test equipment			
PC	PC Manufacturer: Microsoft Corporation Model: L20170076		
<p>Note: 1. The EUT is sent from the applicant to TA and the information of the EUT is declared by the applicant.</p> <p>2. There are more than one Adapter, Earphone and USB Cable, each one should be applied throughout the compliance test respectively, however, only the worst case (Adapter 1, Earphone 2 and USB Cable 1) will be recorded in this report.</p>			



2.3 Applied Standards

According to the specifications of the manufacturer, it must comply with the requirements of the following standards:

Test standards

FCC Code CFR47 Part15B (2021)

ANSI C63.4 (2014)

2.4 Test Mode

Test Mode	
Mode 1:	Adapter + USB cable + Front camera On
Mode 2:	Adapter + USB cable + Rear camera On
Mode 3:	Adapter + USB cable + Mp4
Mode4:	USB Copy(EUT with PC) + USB cable
Mode 5:	Front Camera On +earphone
Mode 6:	Rear camera On +earphone
Mode 7:	Earphone + MP4

During the test, the preliminary test was performed in all modes with all adapters, USB and batteries, mode 4 with USB cable 1 is selected as the worst condition. The test data of the worst-case condition was recorded in this report.

3 Test Case Results

3.1 Radiated Emission

Ambient condition

Temperature	Relative humidity	Pressure
15°C~35°C	30%~60%	101.5kPa

Methods of Measurement

The EUT is placed on a non-metallic table 0.8m above the horizontal metal reference ground plane. The distance between EUT and receive antenna should be 3 meters. During the test, the EUT was operating in its typical mode. The test method is according to ANSI C63.4-2014. Sweep the whole frequency band through the range from 30MHz to the 5th harmonic of the carrier. During the test, the height of receive antenna shall be moved from 1 to 4 meters, and the antenna shall be performed under horizontal and vertical polarization. The turn table shall be rotated from 0 to 360 degrees for detecting the maximum of radiated signal level.

The data of cable loss and antenna factor has been calibrated in full testing frequency range before the testing. During the test, the EUT is worked at maximum output power.

Set the spectrum analyzer in the following:

Below 1GHz:

RBW=100 kHz / VBW=300 kHz / Sweep=AUTO

Above 1GHz:

(a) PEAK Detector: RBW=1MHz / VBW=3MHz/ Sweep=AUTO

(b) AVERAGE Detector: RBW=1MHz / VBW=3MHz / Sweep=AUTO

The radiated emission was measured in the following position: EUT stand-up position (Z axis), lie-down position (X, Y axis). The worst emission was found in lie-down position (X axis) and the worst case was recorded.

Test Setup

Below 1GHz

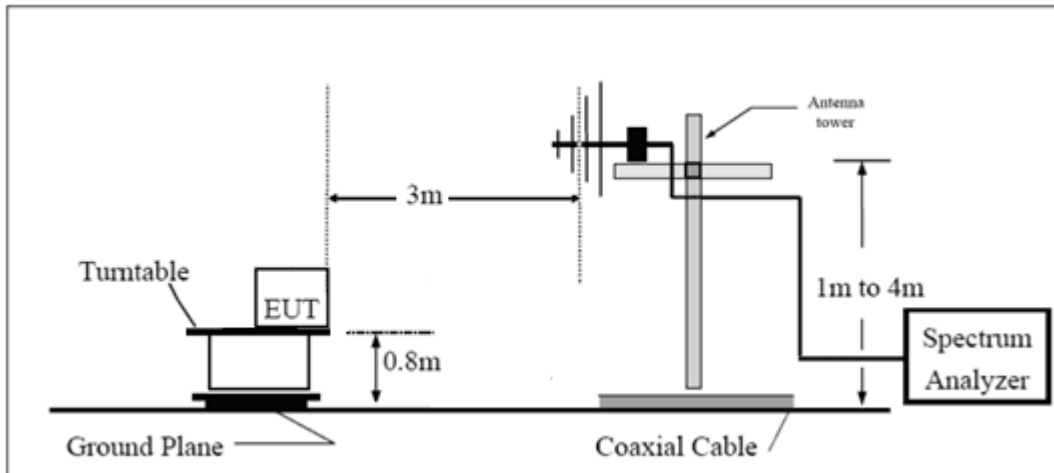

Above 1GHz

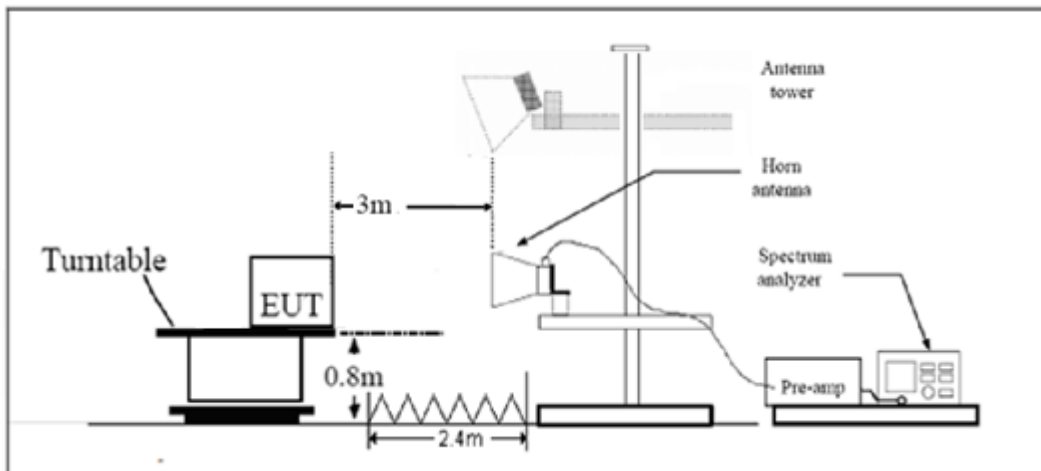

Note: Area side: 2.4mX3.6m

Antenna Tower meets ANSI C63.4 requirements for measurements above 1 GHz by keeping the antenna aimed at the EUT during the antenna's ascent/ descent along the antenna mast.

Limits

Class B

Frequency (MHz)	Field Strength (dB μ V/m)	Detector
30 -88	40.0	Quasi-peak
88-216	43.5	Quasi-peak
216 – 960	46.0	Quasi-peak
960-1000	54.0	Quasi-peak
1000-5 th harmonic of the highest frequency or 40GHz, which is lower	54 74	Average Peak

Measurement Uncertainty

The assessed measurement uncertainty to ensure 95% confidence level for the normal distribution is with the coverage factor $k = 1.96$.

Frequency	Uncertainty
30MHz~200MHz	4.17 dB
200MHz~1000MHz	4.84 dB
1GHz~18GHz	4.35 dB
18GHz~26.5GHz	5.90 dB
26.5GHz~40GHz	5.92 dB

Test Results

Sweep the whole frequency band through the range from 30MHz to the 5th harmonic of the carrier, the Emissions in the frequency band 18GHz –40GHz is more than 20dB below the limit are not reported.

The following graphs display the maximum values of horizontal and vertical by software. For above 1GHz, Blue trace uses the peak detection, Green trace uses the average detection.

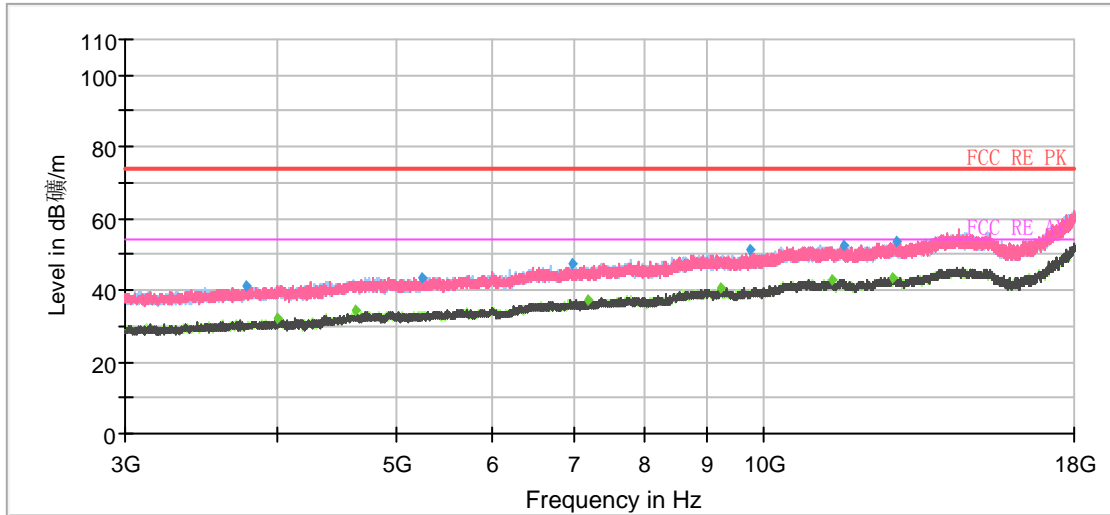

Radiated Emission from 30MHz to 1GHz

Frequency (MHz)	Quasi-Peak (dBuV/m)	Height (cm)	Polarization	Azimuth (deg)	Correct Factor (dB)	Margin (dB)	Limit (dBuV/m)
38.856350	20.88	180.0	V	56.0	13	19.12	40.00
147.955250	23.50	105.0	V	332.0	9	20.00	43.50
240.005000	42.60	105.0	H	206.0	14	3.40	46.00
384.010000	34.07	100.0	H	346.0	17	11.93	46.00
479.918750	35.42	188.0	H	228.0	19	10.58	46.00
723.153750	27.97	213.0	H	9.0	23	18.03	46.00

Remark: 1. Correction Factor = Antenna factor + Insertion loss(cable loss+amplifier gain)

2. Margin = Limit – Quasi-Peak

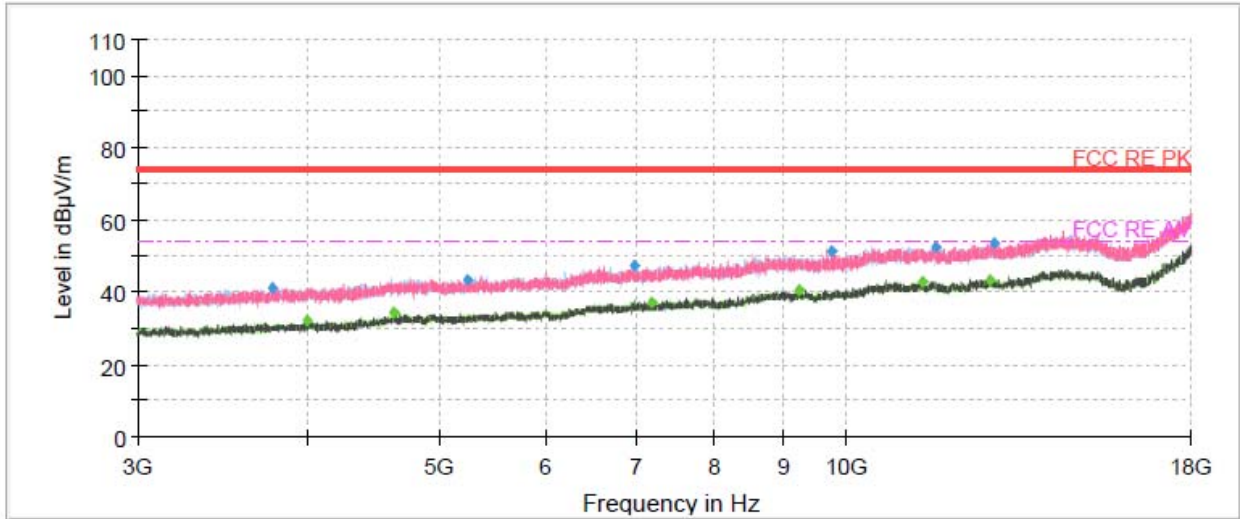

Radiated Emission from 1GHz to 18GHz

Frequency (MHz)	MaxPeak (dB µ V/m)	Average (dB µ V/m)	Limit (dB µ V/m)	Margin (dB)	Height (cm)	Pol	Azimuth (deg)	Corr. (dB/m)
3770.500000	41.40	---	74.00	32.60	200.0	V	359.0	-12
4001.000000	---	31.90	54.00	22.10	100.0	H	354.0	-11
4643.000000	---	34.46	54.00	19.54	100.0	H	350.0	-9
5249.000000	43.67	---	74.00	30.33	100.0	H	0.0	-8
6982.500000	47.51	---	74.00	26.49	200.0	H	15.0	-3
7178.000000	---	37.41	54.00	16.59	100.0	V	78.0	-4
9231.500000	---	40.84	54.00	13.16	100.0	H	307.0	-2
9766.500000	51.16	---	74.00	22.84	100.0	V	135.0	-2
11384.500000	---	42.97	54.00	11.03	200.0	V	55.0	0
11641.500000	52.66	---	74.00	21.34	100.0	V	1.0	1
12766.000000	---	43.43	54.00	10.57	100.0	V	176.0	2
12867.000000	53.38	---	74.00	20.62	100.0	V	176.0	2

3.2 Conducted Emission

Ambient condition

Temperature	Relative humidity	Pressure
15°C~35°C	30%~60%	101.5kPa

Methods of Measurement

The EUT is placed on a non-metallic table of 80cm height above the horizontal metal reference ground plane. During the test, the EUT was operating in its typical mode. The test method is according to ANSI C63.4-2014. Connect the AC power line of the EUT to the L.I.S.N. Use EMI receiver to detect the average and Quasi-peak value. RBW is set to 9 kHz, VBW is set to 30kHz. The measurement result should include both L line and N line.

Test Setup

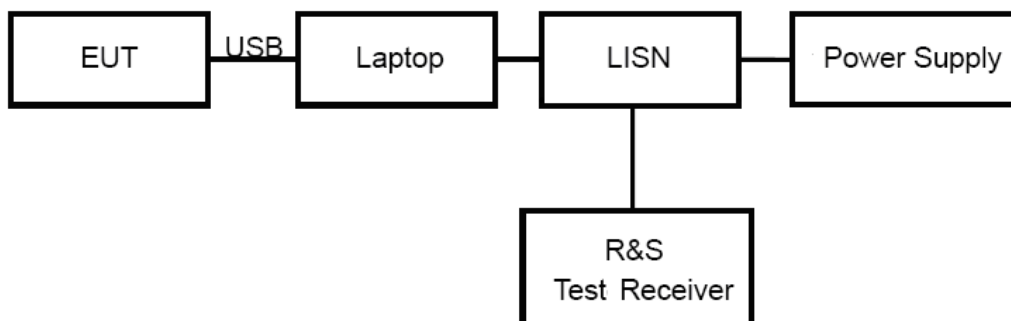

Note: Power Supply is AC Power source and it is used to change the voltage 120V/60Hz.

Limits

Frequency (MHz)	Conducted Limits(dB μ V)	
	Quasi-peak	Average
0.15 - 0.5	66 to 56 *	56 to 46 *
0.5 - 5	56	46
5 - 30	60	50

*: Decreases with the logarithm of the frequency.

Measurement Uncertainty

The assessed measurement uncertainty to ensure 95% confidence level for the normal distribution is with the coverage factor $k = 1.96$. $U = 2.57$ dB.

Test Results

Following plots, Blue trace uses the peak detection; Green trace uses the average detection.

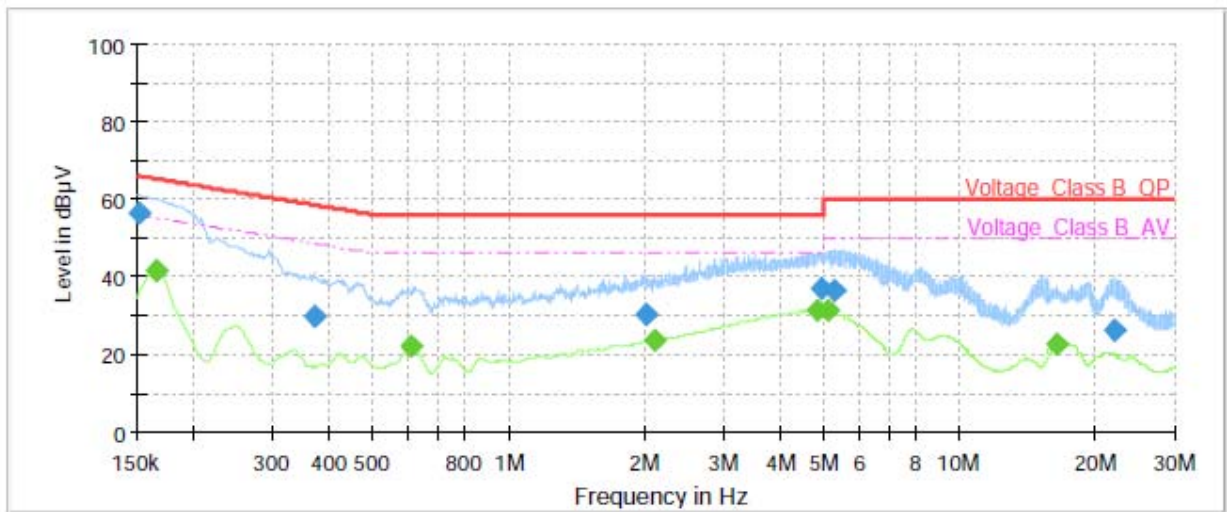

Frequency (MHz)	QuasiPeak (dBµV)	Average (dBµV)	Limit (dBµV)	Margin (dB)	Meas. Time (ms)	Bandwidth (kHz)	Line	Filter	Corr. (dB)
0.15	56.54	---	65.88	9.34	70.0	9.000	L1	ON	21
0.17	---	41.56	55.17	13.61	70.0	9.000	L1	ON	21
0.37	29.84	---	58.49	28.65	70.0	9.000	L1	ON	21
0.61	---	22.06	46.00	23.94	70.0	9.000	L1	ON	20
2.02	30.12	---	56.00	25.88	70.0	9.000	L1	ON	20
2.12	---	23.57	46.00	22.43	70.0	9.000	L1	ON	20
4.84	---	31.49	46.00	14.51	70.0	9.000	L1	ON	19
4.97	36.81	---	56.00	19.19	70.0	9.000	L1	ON	19
5.13	---	31.34	50.00	18.66	70.0	9.000	L1	ON	19
5.27	36.45	---	60.00	23.55	70.0	9.000	L1	ON	19
16.43	---	22.52	50.00	27.48	70.0	9.000	L1	ON	20
22.05	26.07	---	60.00	33.93	70.0	9.000	L1	ON	20

Remark: Correct factor=cable loss + LISN factor

L line

Conducted Emission from 150 KHz to 30 MHz

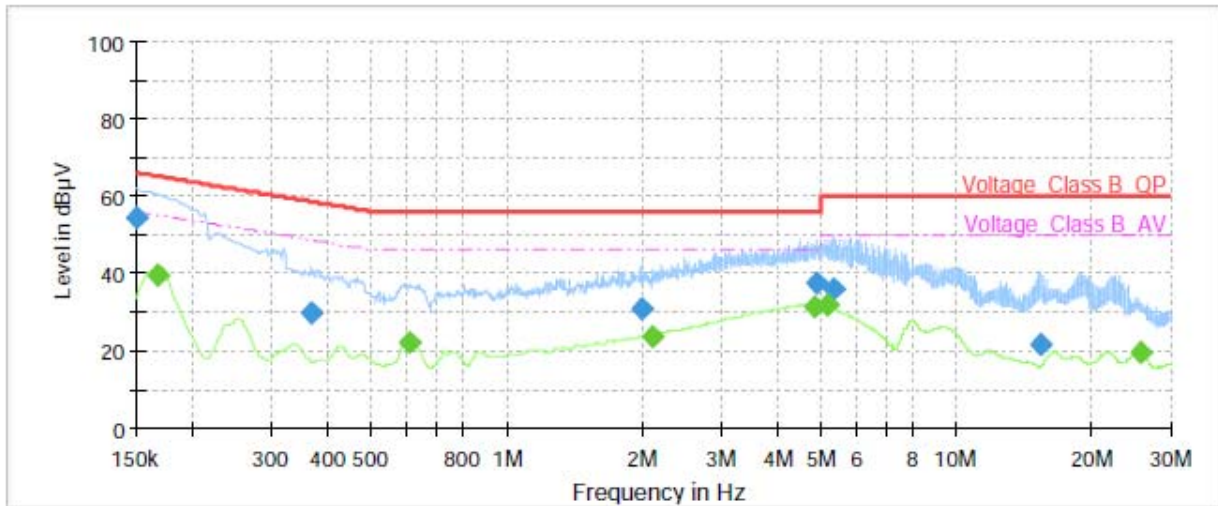

Frequency (MHz)	QuasiPeak (dBµV)	Average (dBµV)	Limit (dBµV)	Margin (dB)	Meas. Time (ms)	Bandwidth (kHz)	Line	Filter	Corr. (dB)
0.15	54.46	---	66.00	11.54	70.0	9.000	N	ON	21
0.17	---	39.28	55.06	15.78	70.0	9.000	N	ON	21
0.37	29.95	---	58.54	28.59	70.0	9.000	N	ON	21
0.60	---	22.27	46.00	23.73	70.0	9.000	N	ON	20
1.99	30.57	---	56.00	25.43	70.0	9.000	N	ON	20
2.11	---	23.77	46.00	22.23	70.0	9.000	N	ON	20
4.81	---	31.07	46.00	14.93	70.0	9.000	N	ON	19
4.89	37.56	---	56.00	18.44	70.0	9.000	N	ON	19
5.16	---	31.73	50.00	18.27	70.0	9.000	N	ON	19
5.31	35.99	---	60.00	24.01	70.0	9.000	N	ON	19
15.45	21.58	---	60.00	38.42	70.0	9.000	N	ON	20
25.82	---	19.50	50.00	30.50	70.0	9.000	N	ON	20

Remark: Correct factor=cable loss + LISN factor

N line

Conducted Emission from 150 KHz to 30 MHz

4 Main Test Instruments

Name	Manufacturer	Type	Serial Number	Calibration Date	Expiration Time
Spectrum Analyzer	R&S	FSV40	100815	2020-12-13	2021-12-12
EMI Test Receiver	R&S	ESCI7	100936	2020-12-13	2021-12-13
Trilog Antenna	SCHWARZBECK	VULB 9163	391	2019-12-16	2022-12-15
Horn Antenna	Schwarzbeck	BBHA 9120D	430	2018-07-07	2023-07-06
Horn Antenna	ETS-Lindgren	3160-09	00102643	2018-06-20	2023-06-19
EMI Test Receiver	R&S	ESR	101667	2021-05-16	2022-05-15
LISN	R&S	ENV216	101171	2018-12-15	2021-12-14
Bore Sight Antenna mast	ETS	2171B	00058752	/	/
Test software	EMC32	R&S	9.26.0	/	/

*****END OF REPORT *****



ANNEX A: The EUT Appearance

The EUT Appearance are submitted separately.



ANNEX B: Test Setup Photos

The Test Setup Photos are submitted separately.



ANNEX C: Product Change Description (Variant 1)

The Product Change Description are submitted separately.



ANNEX D: Product Change Description (Variant 2)

The Product Change Description are submitted separately.