



RF TEST REPORT

Applicant ZTE Corporation
FCC ID SRQ-A2023PG
Product 5G NR Multi model smart phone
Model ZTE A2023PG
Report No. R2205A0428-R1
Issue Date June 10, 2022

TA Technology (Shanghai) Co., Ltd. tested the above equipment in accordance with the requirements in **FCC CFR47 Part 2 (2021)/ FCC CFR 47 Part 22H (2021)**. The test results show that the equipment tested is capable of demonstrating compliance with the requirements as documented in this report.

Prepared by: Peng Tao

Approved by: Kai Xu

TA Technology (Shanghai) Co., Ltd.

No.145, Jintang Rd, Tangzhen Industry Park, Pudong Shanghai, China

TEL: +86-021-50791141/2/3

FAX: +86-021-50791141/2/3-8000



TABLE OF CONTENT

1. Test Laboratory	4
1.1. Notes of the Test Report	4
1.2. Test facility	4
1.3. Testing Location	4
2. General Description of Equipment under Test.....	5
2.1. Applicant and Manufacturer Information	5
2.2. General Information.....	5
3. Applied Standards.....	7
4. Test Configuration.....	8
5. Test Case.....	10
5.1. RF Power Output and Effective Radiated Power	10
5.2. Occupied Bandwidth	11
5.3. Band Edge Compliance.....	12
5.4. Peak-to-Average Power Ratio (PAPR)	13
5.5. Frequency Stability.....	14
5.6. Spurious Emissions at Antenna Terminals	16
5.7. Radiates Spurious Emission	17
6. Test Result	20
6.1. RF Power Output and Effective Radiated Power	20
6.2. Occupied Bandwidth	24
6.3. Band Edge Compliance.....	34
6.4. Peak-to-Average Power Ratio (PAPR)	44
6.5. Frequency Stability.....	46
6.6. Spurious Emissions at Antenna Terminals	49
6.7. Radiates Spurious Emission	53
7. Main Test Instruments	56
ANNEX A: The EUT Appearance.....	57
ANNEX B: Test Setup Photos	58



Summary of measurement results

No.	Test Case	Clause in FCC rules	Verdict
1	RF Power Output and Effective Radiated Power	2.1046 22.913(a)(5)	PASS
2	Occupied Bandwidth	2.1049	PASS
3	Band Edge Compliance	2.1051 / 22.917(a)	PASS
4	Peak-to-Average Power Ratio	22.913(d)/ KDB 971168 D01(5.7)	PASS
5	Frequency Stability	2.1055 / 22.355	PASS
6	Spurious Emissions at Antenna Terminals	2.1051 / 22.917(a)	PASS
7	Radiates Spurious Emission	2.1053 / 22.917 (a)	PASS

Date of Testing: March 18, 2022 and May 12, 2022

Date of Sample Received: March 17, 2022

Note: PASS: The EUT complies with the essential requirements in the standard.

FAIL: The EUT does not comply with the essential requirements in the standard.

All indications of Pass/Fail in this report are opinions expressed by TA Technology (Shanghai) Co., Ltd. based on interpretations and/or observations of test results. Measurement Uncertainties were not taken into account and are published for informational purposes only.



1. Test Laboratory

1.1. Notes of the Test Report

This report shall not be reproduced in full or partial, without the written approval of **TA technology (shanghai) co., Ltd.** The results documented in this report apply only to the tested sample, under the conditions and modes of operation as described herein. Measurement Uncertainties were not taken into account and are published for informational purposes only. This report is written to support regulatory compliance of the applicable standards stated above.

1.2. Test facility

FCC (Designation number: CN1179, Test Firm Registration Number: 446626)

TA Technology (Shanghai) Co., Ltd. has been listed on the US Federal Communications Commission list of test facilities recognized to perform measurements.

A2LA (Certificate Number: 3857.01)

TA Technology (Shanghai) Co., Ltd. has been listed by American Association for Laboratory Accreditation to perform measurement.

1.3. Testing Location

Company: TA Technology (Shanghai) Co., Ltd.
Address: No.145, Jintang Rd, Tangzhen Industry Park, Pudong
City: Shanghai
Post code: 201201
Country: P. R. China
Contact: Xu Kai
Telephone: +86-021-50791141/2/3
Fax: +86-021-50791141/2/3-8000
Website: <http://www.ta-shanghai.com>
E-mail: xukai@ta-shanghai.com

2. General Description of Equipment under Test

2.1. Applicant and Manufacturer Information

Applicant	ZTE Corporation
Applicant address	ZTE Plaza, #55 Keji Road South, Hi-Tech Industrial Park, Nanshan District, Shenzhen, China
Manufacturer	ZTE Corporation
Manufacturer address	ZTE Plaza, #55 Keji Road South, Hi-Tech Industrial Park, Nanshan District, Shenzhen, China

2.2. General Information

EUT Description			
Model	ZTE A2023PG		
SN	327324440042		
Hardware Version	ZTE A2023PGHW1.0		
Software Version	MyOS12.0.2_A2023PG_GLB		
Power Supply	Battery / AC adapter		
Antenna Type	Internal Antenna		
Antenna Gain	Band	Antenna 1 Gain(dBi)	Antenna 6 Gain(dBi)
	GSM 850:	-5.0	-8.5
	WCDMA Band V:	-5.0	-8.5
	LTE Band 5:	-5.0	-8.5
Test Mode(s)	GSM 850; WCDMA Band V; LTE Band 5;		
Test Modulation	(GSM/GPRS)GMSK, (EGPRS) GMSK/ 8PSK; (WCDMA) BPSK, QPSK,16QAM; (LTE) QPSK, 16QAM, 64QAM;		
GPRS Multislot Class	12		
EGPRS Multislot Class	12		
HSDPA UE Category	24		
HSUPA UE Category	6		
HSPA+ UE Category	7		
Maximum E.R.P.	GSM 850	25.27dBm	
	WCDMA Band V	17.07dBm	
	LTE Band 5	18.01dBm	
Rated Power Supply Voltage	3.89V		
Operating Voltage	Minimum: 3.70V Maximum: 4.45V		
Operating Temperature	Lowest: -10°C Highest: +40°C		
Testing Temperature	Lowest: -30°C Highest: +50°C		



Operating Frequency Range(s)	Band	Tx (MHz)	Rx (MHz)
	GSM850	824 ~ 849	869 ~ 894
	WCDMA Band V	824 ~ 849	869 ~ 894
	LTE Band 5	824 ~ 849	869 ~ 894
EUT Accessory			
Adapter	Manufacturer: ShenZhen KunXing Technology Co., Ltd. Model: STC-A59152050AC-Z		
Battery	Manufacturer: Zhuhai Cosmx Battery Co., Ltd. Model: Li3949T44P8h806459		
Earphone 1	Manufacturer: JUWEI ELECTRONICS CO.,LTD Model: JWEP1092-Z01		
Earphone 2	Manufacturer: ShenZhen FDC Electronic Co.,Ltd Model: DEM-9A		
USB Cable 1	Manufacturer: King Power Electronics Co., Ltd Model: TC20-TC20-W-100-M-6A-HSF		
USB Cable 2	Manufacturer: Luxshare-ICT Co., Ltd Model: TC20-TC20-W-100-M-6A-HSF		
Type-C to 3.5 mm Headphone Jack	Manufacturer: JUWEI ELECTRONICS CO., LTD Model: 080503000100		
Note: 1. The EUT is sent from the applicant to TA and the information of the EUT is declared by the applicant. 2. There is more than one USB cable/ Earphone, each one should be applied throughout the compliance test respectively, and however, only the worst case (USB cable 1) will be recorded in this report.			



3. Applied Standards

According to the specifications of the manufacturer, it must comply with the requirements of the following standards:

Test standards:

FCC CFR 47 Part 22H (2021)

FCC CFR47 Part 2 (2021)

Reference standard:

ANSI C63.26-2015

KDB 971168 D01 Power Meas License Digital Systems v03r01

4. Test Configuration

There is more than one SIM card slot, each one should be applied throughout the compliance test respectively, and however, only the worst case (SIM 1) will be recorded in this report.

Radiated measurements are performed by rotating the EUT in three different orthogonal test planes. EUT stand-up position (Z axis), lie-down position (X, Y axis). Receiver antenna polarization (horizontal and vertical), the worst emission was found in position (Z axis, horizontal polarization for GSM/WCDMA, X axis, vertical polarization for LTE) and the worst case was recorded.

All mode and data rates and positions and RB size and modulations were investigated. Subsequently, only the worst case emissions are reported.

The following testing in GSM/WCDMA/LTE is set based on the maximum RF Output Power.

Test modes are chosen to be reported as the worst case configuration below:

Test items	Modes/Modulation	
	GSM 850	WCDMA Band V
RF Power Output and Effective Radiated power	GSM GPRS EGPRS	RMC/AMR HSDPA/HSUPA DC-HSDPA/HSPA+
Occupied Bandwidth	GSM GPRS(1Tx slot) EGPRS(1Tx slot)	RMC
Band Edge Compliance	GSM GPRS(1Tx slot) EGPRS(1Tx slot)	RMC
Peak-to-Average Power Ratio	GSM GPRS(1Tx slot) EGPRS(1Tx slot)	RMC
Frequency Stability	GSM GPRS(1Tx slot) EGPRS(1Tx slot)	RMC
Spurious Emissions at Antenna Terminals	GSM	RMC
Radiates Spurious Emission	GSM	RMC



Test modes are chosen as the worst case configuration below for LTE Band 5

Test items	Bandwidth (MHz)				Modulation		RB			Test Channel		
	1.4	3	5	10	QPSK	16QAM/ 64QAM	1	50%	100%	L	M	H
RF power output and Effective Radiated power	O	O	O	O	O	O	O	O	O	O	O	O
Occupied Bandwidth	O	O	O	O	O	O	-	-	O	O	O	O
Band Edge Compliance	O	O	O	O	O	O	O	-	O	O	-	O
Peak-to-Average Power Ratio	O	O	O	O	O	O	-	-	O	O	O	O
Frequency Stability	O	O	O	O	O	O	O	-	-	-	O	-
Spurious Emissions at Antenna Terminals	O	O	O	O	O	-	O	-	-	O	O	O
Radiates Spurious Emission	O	-	O	O	O	-	O	-	-	-	O	-
Note	1. The mark "O" means that this configuration is chosen for testing. 2. The mark "-" means that this configuration is not testing.											

5. Test Case

5.1. RF Power Output and Effective Radiated Power

Ambient condition

Temperature	Relative humidity	Pressure
23°C ~25°C	45%~50%	101.5kPa

Methods of Measurement

During the process of the testing, The EUT was connected to the Base Station Simulator with a known loss. The EUT is controlled by the Base Station Simulator test set to ensure max power transmission with proper modulation.

ERP can then be calculated as follows:

$$\text{EIRP (dBm)} = \text{Output Power (dBm)} - \text{Losses (dB)} + \text{Antenna Gain (dBi)}$$

where:dBd refers to gain relative to an ideal dipole.

$$\text{EIRP (dBm)} = \text{ERP (dBm)} + 2.15 \text{ (dB)}.$$

Test Setup

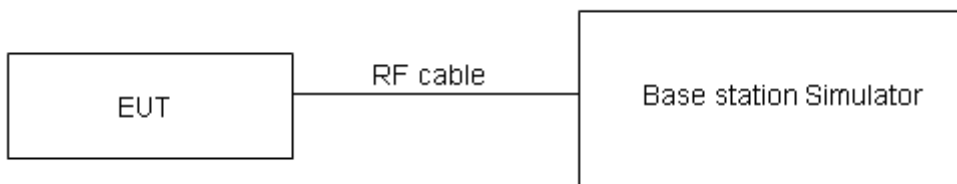

Limits

No specific RF power output requirements in part 2.1046.

Rule Part 22.913(a)(5) specifies that "Mobile/portable stations are limited to 7 watts ERP".

Limit	$\leq 7 \text{ W}$ (38.45 dBm)
-------	--------------------------------

Measurement Uncertainty

The assessed measurement uncertainty to ensure 95% confidence level for the normal distribution is with the coverage factor $k = 2$, $U = 0.4 \text{ dB}$ for RF power output, $k = 2$, $U = 1.19 \text{ dB}$ for ERP.

Test Results

Refer to the section 6.1 of this report for test data.

5.2. Occupied Bandwidth

Ambient condition

Temperature	Relative humidity	Pressure
23°C ~25°C	45%~50%	101.5kPa

Method of Measurement

The EUT was connected to Spectrum Analyzer and Base Station Simulator via power Splitter. The occupied bandwidth is measured using spectrum analyzer.

RBW is set to $\geq 1\%EBW$, VBW is set to 3x RBW.

99% power and -26dBc occupied bandwidths are recorded. Spectrum analyzer plots are included on the following pages.

Test Setup

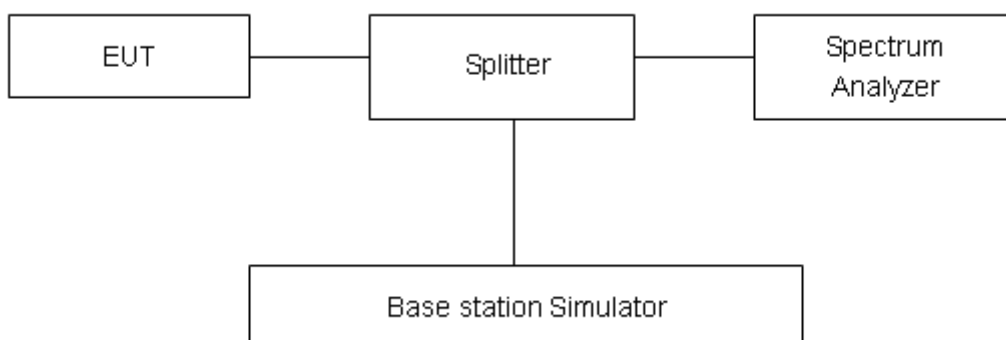

Limits

No specific occupied bandwidth requirements in part 2.1049.

Measurement Uncertainty

The assessed measurement uncertainty to ensure 95% confidence level for the normal distribution is with the coverage factor $k = 2$, $U = 624\text{Hz}$.

Test Results

Refer to the section 6.2 of this report for test data.

5.3. Band Edge Compliance

Ambient condition

Temperature	Relative humidity	Pressure
23°C ~25°C	45%~50%	101.5kPa

Method of Measurement

The EUT was connected to Spectrum Analyzer and Base Station Simulator via power Splitter. The band edge of the lowest and highest channels were measured. The average detector is used. RBW is set to $\geq 1\%EBW$, VBW is set to 3x RBW.

Spectrum analyzer plots are included on the following pages.

Test Setup

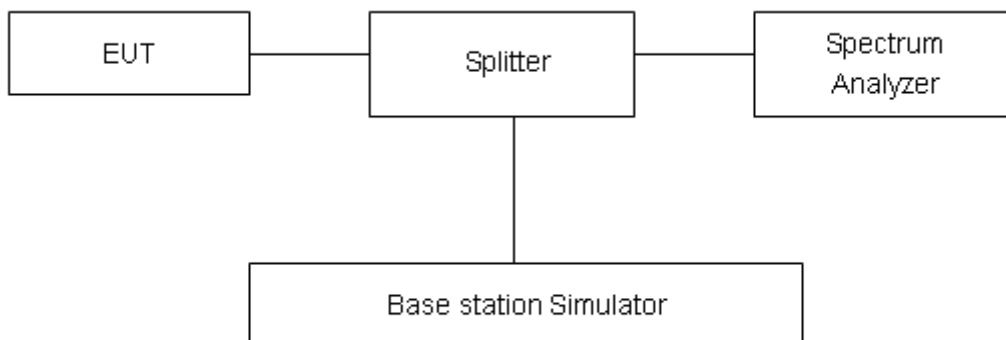

Limits

Rule Part 22.917(a) specifies that “The power of any emission outside of the authorized operating frequency ranges must be attenuated below the transmitting power (P) by a factor of at least 43 + 10 log(P) dB.”

Limit	-13 dBm
-------	---------

Measurement Uncertainty

The assessed measurement uncertainty to ensure 95% confidence level for the normal distribution is with the coverage factor $k = 1.96$, $U=0.684dB$.

Test Results

Refer to the section 6.3 of this report for test data.

5.4. Peak-to-Average Power Ratio (PAPR)

Ambient condition

Temperature	Relative humidity	Pressure
23°C ~25°C	45%~50%	101.5kPa

Methods of Measurement

Measure the total peak power and record as P_{Pk} . And measure the total average power and record as P_{Avg} . Both the peak and average power levels must be expressed in the same logarithmic units (e.g., dBm). Determine the PAPR from:

$$PAPR (dB) = P_{Pk} (dBm) - P_{Avg} (dBm).$$

Test Setup

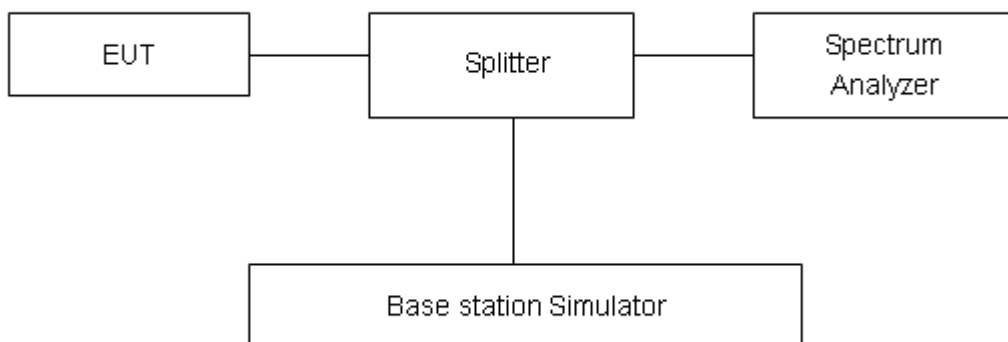

Limits

According to the Sec. 22.913(d), The peak-to-average ratio (PAR) of the transmission must not exceed 13 dB.

Measurement Uncertainty

The assessed measurement uncertainty to ensure 95% confidence level for the normal distribution is with the coverage factor $k = 2$, $U = 0.4$ dB.

Test Results

Refer to the section 6.4 of this report for test data.

5.5. Frequency Stability

Ambient condition

Temperature	Relative humidity	Pressure
23°C ~25°C	45%~50%	101.5kPa

Method of Measurement

Frequency Stability (Temperature Variation)

The temperature inside the climate chamber is varied from -30°C to +50°C in 10°C step size,

(1) With all power removed, the temperature was decreased to 0°C and permitted to stabilize for three hours.

(2) Measure the carrier frequency with the test equipment in a “call mode”. These measurements should be made within 1 minute of powering up the mobile station, to prevent significant self warming.

(3) Repeat the above measurements at 10°C increments from -30°C to +50°C. Allow at least 1.5 hours at each temperature, un-powered, before making measurements. Frequency Stability (Voltage Variation)

The frequency stability shall be measured with variation of primary supply voltage as follows:

Primary Supply Voltage: The primary supply voltage is varied from 85% to 115% of the nominal value for non hand-carried battery and AC powered equipment. For hand-carried, battery-powered equipment, primary supply voltage is reduced to the battery operating end point which shall be specified by the manufacturer.

This transceiver is specified to operate with an input voltage of between 3.70 V and 4.45 V, with a nominal voltage of 3.89V.

Test setup

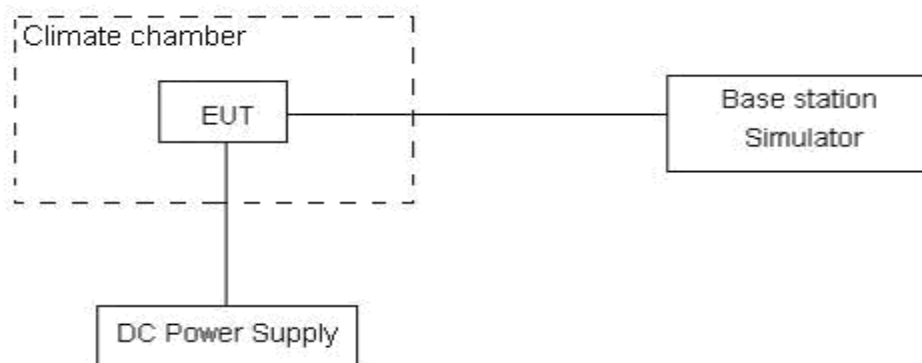

Limits

According to the Sec. 22.355, the frequency stability of the carrier shall be accurate to within 2.5 ppm of the received frequency for mobile stations.

Limits	≤ 2.5 ppm
--------	-----------

Measurement Uncertainty

The assessed measurement uncertainty to ensure 99.75% confidence level for the normal distribution is with the coverage factor $k = 3$, $U = 0.01\text{ppm}$.



Test Results

Refer to the section 6.5 of this report for test data.

5.6. Spurious Emissions at Antenna Terminals

Ambient condition

Temperature	Relative humidity	Pressure
23°C ~25°C	45%~50%	101.5kPa

Method of Measurement

The EUT was connected to Spectrum Analyzer and Base Station Simulator via power Splitter. The measurement is carried out using a spectrum analyzer. The spectrum analyzer scans from 9kHz to the 10th harmonic of the carrier.

The peak detector is used. RBW are set to 100 kHz and VBW are set to 300 kHz for below 1G, RBW are set to 1MHz and VBW are set to 3MHz for above 1G, Sweep is set to ATUO.

RBW is set to 1 kHz (0.009MHz~ 0.15 MHz),

RBW is set to 10 kHz (0.15 MHz~ 30 MHz)

RBW is set to 100 kHz (30MHz~1000 MHz)

RBW is set to 1000 kHz (above 1000MHz)

The modulation mode and RB allocation refer to section 5.1, using the maximum output power configuration.

Test setup

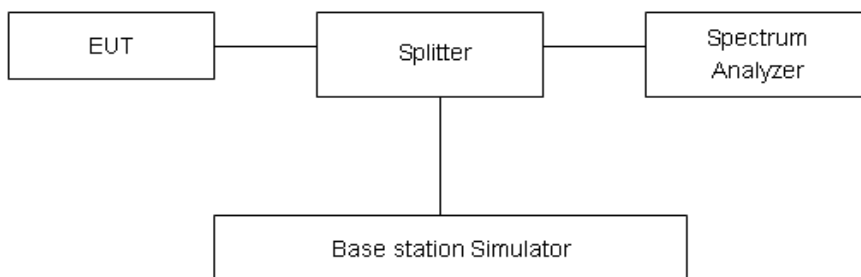

Limits

Rule Part 22.917(a) specifies that “The power of any emission outside of the authorized operating frequency ranges must be attenuated below the transmitting power (P) by a factor of at least 43 + 10 log (P) dB.”

Limit	-13 dBm

Measurement Uncertainty

The assessed measurement uncertainty to ensure 99.75% confidence level for the normal distribution is with the coverage factor $k = 1.96$.

Frequency	Uncertainty
9kHz-1GHz	0.684 dB
1GHz-30GHz	1.407 dB

Test Results

Refer to the section 6.6 of this report for test data.

5.7. Radiates Spurious Emission

Ambient condition

Temperature	Relative humidity	Pressure
23°C ~25°C	45%~50%	101.5kPa

Method of Measurement

1. The testing follows FCC KDB 971168 v03r01 Section 5.8 and ANSI C63.26 (2015).
2. Below 1GHz: The EUT is placed on a turntable 0.8 meters above the ground in the chamber, 3 meter away from the antenna. The maximal emission value is acquired by adjusting the antenna height, polarisation and turntable azimuth. Normally, the height range of antenna is 1 m to 4 m, the azimuth range of turntable is 0° to 360°, and the receive antenna has two polarizations Vertical (V) and Horizontal (H). Above 1GHz: (Note: the FCC's permission to use 1.5m as an alternative per TCBC Conf call of Dec. 2, 2014.) The EUT is placed on a turntable 1.5 meters above the ground in the chamber, 3 meter away from the antenna. The maximal emission value is acquired by adjusting the antenna height, polarisation and turntable azimuth. Normally, the height range of antenna is 1 m to 4 m, the azimuth range of turntable is 0° to 360°, and the receive antenna has two polarizations Vertical (V) and Horizontal (H).
3. A loop antenna, A log-periodic antenna or horn antenna shall be substituted in place of the EUT. The log-periodic antenna will be driven by a signal generator and the level will be adjusted till the same power value on the spectrum analyzer or receiver. The level of the spurious emissions can be calculated through the level of the signal generator, cable loss, the gain of the substitution antenna and the reading of the spectrum analyzer or receiver.
4. The EUT is then put into continuously transmitting mode at its maximum power level during the test. Set Test Receiver or Spectrum RBW=100kHz,VBW=300kHz, and the maximum value of the receiver should be recorded as (Pr).
5. The EUT shall be replaced by a substitution antenna. In the chamber, an substitution antenna for the frequency band of interest is placed at the reference point of the chamber. An RF Signal source for the frequency band of interest is connected to the substitution antenna with a cable that has been constructed to not interfere with the radiation pattern of the antenna. A power (PMea) is applied to the input of the substitution antenna, and adjust the level of the signal generator output until the value of the receiver reach the previously recorded (Pr). The power of signal source (PMea) is recorded. The test should be performed by rotating the test item and adjusting the receiving antenna polarization.
6. A amplifier should be connected to the Signal Source output port. And the cable should be connect between the Amplifier and the Substitution Antenna. The cable loss (Pcl) ,the Substitution Antenna Gain (Ga) and the Amplifier Gain (PAg) should be recorded after test.
7. The measurement results are obtained as described below:
$$\text{Power(EIRP)} = \text{PMea} - \text{PAg} - \text{Pcl} + \text{Ga}$$

The measurement results are amend as described below:
$$\text{Power(EIRP)} = \text{PMea} - \text{Pcl} + \text{Ga}$$
8. This value is EIRP since the measurement is calibrated using an antenna of known gain (2.15 dB) and known input power. ERP can be calculated from EIRP by subtracting the gain of the dipole, ERP

= EIRP-2.15dB.

The modulation mode and RB allocation refer to section 5.1, using the maximum output power configuration.

Test setup

9KHz ~ 30MHz

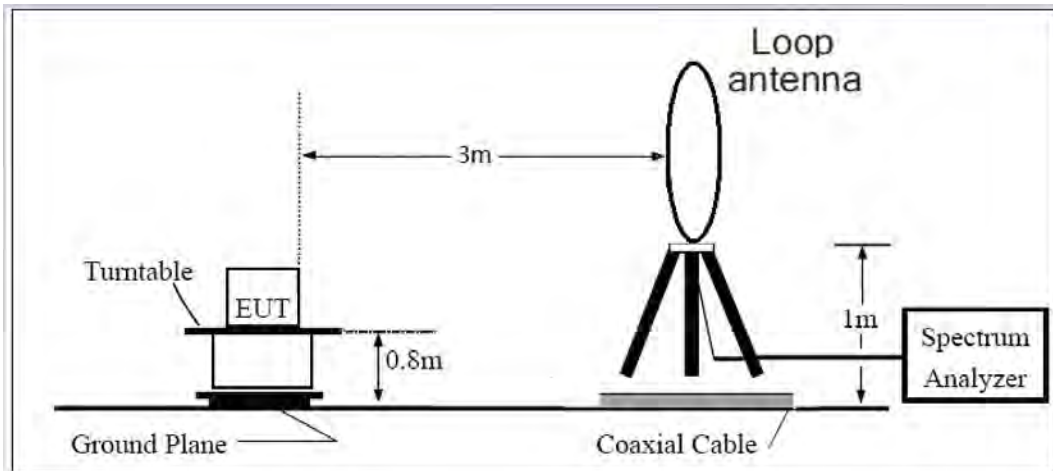

30MHz ~ 1GHz

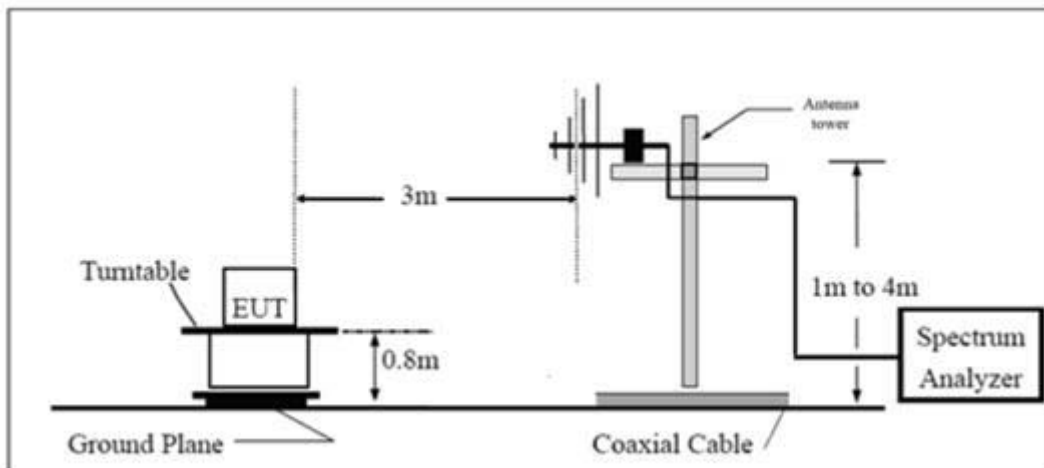

Above 1GHz

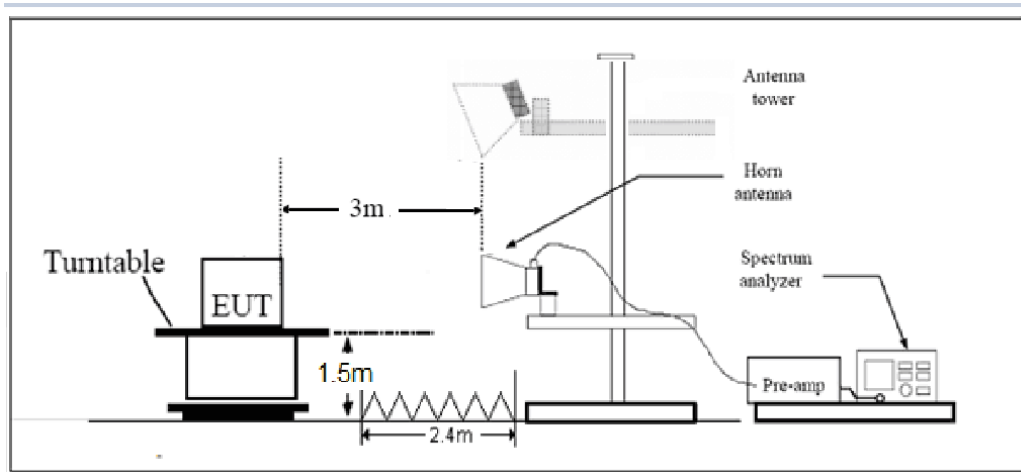

Note: Area side:2.4mX3.6m

Limits

Rule Part 22.917(a) specifies that “The power of any emission outside of the authorized operating frequency ranges must be attenuated below the transmitting power (P) by a factor of at least $43 + 10 \log (P)$ dB.”

Limit	-13 dBm
-------	---------

Measurement Uncertainty

The assessed measurement uncertainty to ensure 95% confidence level for the normal distribution is with the coverage factor $k = 1.96$, $U = 3.55$ dB.

Test Results

Refer to the section 6.7 of this report for test data.



6. Test Result

6.1. RF Power Output and Effective Radiated Power

GSM 850		Maximum Output Power (dBm)			Antenna 1 ERP (dBm)			Antenna 6 ERP (dBm)		
		Channel 128	Channel 190	Channel 251	Channel 128	Channel 190	Channel 251	Channel 128	Channel 190	Channel 251
		824.2 (MHz)	836.6 (MHz)	848.8 (MHz)	824.2 (MHz)	836.6 (MHz)	848.8 (MHz)	824.2 (MHz)	836.6 (MHz)	848.8 (MHz)
GSM(GMSK)	Results	32.06	32.22	32.42	24.91	25.07	25.27	21.41	21.57	21.77
GPRS/EGPRS (GMSK)	1TXslot	31.92	32.11	32.40	24.77	24.96	25.25	21.27	21.46	21.75
	2TXslots	30.22	30.45	30.35	23.07	23.30	23.20	19.57	19.80	19.70
	3TXslots	28.00	28.15	28.20	20.85	21.00	21.05	17.35	17.50	17.55
	4TXslots	27.04	26.92	27.10	19.89	19.77	19.95	16.39	16.27	16.45
EGPRS (8PSK)	1TXslot	26.35	26.37	26.44	19.20	19.22	19.29	15.70	15.72	15.79
	2TXslots	23.94	24.09	23.98	16.79	16.94	16.83	13.29	13.44	13.33
	3TXslots	22.13	22.16	22.20	14.98	15.01	15.05	11.48	11.51	11.55
	4TXslots	21.12	21.21	21.21	13.97	14.06	14.06	10.47	10.56	10.56

WCDMA Band V		Maximum Output Power (dBm)			Antenna 1 ERP (dBm)			Antenna 6 ERP (dBm)		
		Channel 4132	Channel 4183	Channel 4233	Channel 4132	Channel 4183	Channel 4233	Channel 4132	Channel 4183	Channel 4233
		826.4 (MHz)	836.6 (MHz)	846.6 (MHz)	826.4 (MHz)	836.6 (MHz)	846.6 (MHz)	826.4 (MHz)	836.6 (MHz)	846.6 (MHz)
RMC		24.13	24.16	24.22	16.98	17.01	17.07	13.48	13.51	13.57
AMR		24.06	24.11	24.14	16.91	16.96	16.99	13.41	13.46	13.49
HSDPA	Sub - Test 1	23.59	23.58	23.66	16.44	16.43	16.51	12.94	12.93	13.01
	Sub - Test 2	23.58	23.60	23.63	16.43	16.45	16.48	12.93	12.95	12.98
	Sub - Test 3	23.05	23.10	23.15	15.90	15.95	16.00	12.40	12.45	12.50
	Sub - Test 4	23.06	23.11	23.13	15.91	15.96	15.98	12.41	12.46	12.48
HSUPA	Sub - Test 1	23.55	23.57	23.61	16.40	16.42	16.46	12.90	12.92	12.96
	Sub - Test 2	22.54	22.55	22.60	15.39	15.40	15.45	11.89	11.90	11.95
	Sub - Test 3	23.01	23.03	23.09	15.86	15.88	15.94	12.36	12.38	12.44
	Sub - Test 4	22.47	22.52	22.57	15.32	15.37	15.42	11.82	11.87	11.92
	Sub - Test 5	23.48	23.50	23.55	16.33	16.35	16.40	12.83	12.85	12.90
DC-HSDPA	Sub - Test 1	23.47	23.52	23.56	16.32	16.37	16.41	12.82	12.87	12.91
	Sub - Test 2	23.46	23.51	23.55	16.31	16.36	16.40	12.81	12.86	12.90
	Sub - Test 3	23.04	23.00	23.06	15.89	15.85	15.91	12.39	12.35	12.41
	Sub - Test 4	23.03	22.99	23.05	15.88	15.84	15.90	12.38	12.34	12.40
HSPA+	16QAM	23.02	23.07	23.12	15.87	15.92	15.97	12.37	12.42	12.47



LTE Band 5				Maximum Output Power(dBm)			Antenna 1 ERP (dBm)			Antenna 6 ERP (dBm)		
BW	Modulation	RB size	RB offset	Channel/Frequency(MHz)								
				20407 /824.7	20525 /836.5	20643 /848.3	20407 /824.7	20525 /836.5	20643 /848.3	20407 /824.7	20525 /836.5	20643 /848.3
1.4MHz	QPSK	1	0	25.04	25.01	25.13	17.89	17.86	17.98	14.39	14.36	14.48
		1	2	25.03	24.97	25.10	17.88	17.82	17.95	14.38	14.32	14.45
		1	5	24.97	24.97	25.05	17.82	17.82	17.90	14.32	14.32	14.40
		3	0	24.94	24.99	25.04	17.79	17.84	17.89	14.29	14.34	14.39
		3	2	24.98	25.07	25.14	17.83	17.92	17.99	14.33	14.42	14.49
		3	3	25.00	25.02	25.11	17.85	17.87	17.96	14.35	14.37	14.46
		6	0	24.08	24.12	24.21	16.93	16.97	17.06	13.43	13.47	13.56
	16QAM	1	0	24.26	24.61	24.42	17.11	17.46	17.27	13.61	13.96	13.77
		1	2	24.43	24.37	24.36	17.28	17.22	17.21	13.78	13.72	13.71
		1	5	24.35	24.43	24.14	17.20	17.28	16.99	13.70	13.78	13.49
		3	0	23.91	23.95	24.07	16.76	16.80	16.92	13.26	13.30	13.42
		3	2	24.06	24.06	24.15	16.91	16.91	17.00	13.41	13.41	13.50
		3	3	24.03	24.09	24.14	16.88	16.94	16.99	13.38	13.44	13.49
		6	0	23.07	23.13	23.26	15.92	15.98	16.11	12.42	12.48	12.61
	64QAM	1	0	23.32	23.36	23.26	16.17	16.21	16.11	12.67	12.71	12.61
		1	2	23.28	23.37	23.37	16.13	16.22	16.22	12.63	12.72	12.72
		1	5	23.38	23.28	23.28	16.23	16.13	16.13	12.73	12.63	12.63
		3	0	22.91	22.93	23.02	15.76	15.78	15.87	12.26	12.28	12.37
		3	2	23.03	23.07	23.16	15.88	15.92	16.01	12.38	12.42	12.51
		3	3	22.99	23.06	23.11	15.84	15.91	15.96	12.34	12.41	12.46
		6	0	22.06	22.16	22.22	14.91	15.01	15.07	11.41	11.51	11.57
BW	Modulation	RB size	RB offset	Channel/Frequency(MHz)								
				20415 /825.5	20525 /836.5	20635 /847.5	20415 /825.5	20525 /836.5	20635 /847.5	20415 /825.5	20525 /836.5	20635 /847.5
3MHz	QPSK	1	0	25.06	25.05	25.16	17.91	17.90	18.01	14.41	14.40	14.51
		1	7	25.01	25.00	25.14	17.86	17.85	17.99	14.36	14.35	14.49
		1	14	25.00	25.02	25.09	17.85	17.87	17.94	14.35	14.37	14.44
		8	0	24.04	24.11	24.17	16.89	16.96	17.02	13.39	13.46	13.52
		8	4	24.10	24.17	24.26	16.95	17.02	17.11	13.45	13.52	13.61
		8	7	24.10	24.13	24.21	16.95	16.98	17.06	13.45	13.48	13.56
		15	0	24.08	24.16	24.24	16.93	17.01	17.09	13.43	13.51	13.59
	16QAM	1	0	24.26	24.63	24.45	17.11	17.48	17.30	13.61	13.98	13.80
		1	7	24.43	24.37	24.40	17.28	17.22	17.25	13.78	13.72	13.75
		1	14	24.37	24.47	24.17	17.22	17.32	17.02	13.72	13.82	13.52
		8	0	23.02	23.08	23.19	15.87	15.93	16.04	12.37	12.43	12.54
		8	4	23.17	23.19	23.27	16.02	16.04	16.12	12.52	12.54	12.62
		8	7	23.13	23.21	23.27	15.98	16.06	16.12	12.48	12.56	12.62



BW	Modulation	RB size	RB offset	Channel/Frequency(MHz)									
				20425 /826.5	20525 /836.5	20625 /846.5	20425 /826.5	20525 /836.5	20625 /846.5	20425 /826.5	20525 /836.5	20625 /846.5	
5MHz	64QAM	15	0	23.10	23.17	23.29	15.95	16.02	16.14	12.45	12.52	12.64	
		1	0	23.35	23.38	23.29	16.20	16.23	16.14	12.70	12.73	12.64	
		1	7	23.31	23.37	23.39	16.16	16.22	16.24	12.66	12.72	12.74	
		1	14	23.40	23.27	23.31	16.25	16.12	16.16	12.75	12.62	12.66	
		8	0	22.02	22.06	22.14	14.87	14.91	14.99	11.37	11.41	11.49	
		8	4	22.14	22.20	22.28	14.99	15.05	15.13	11.49	11.55	11.63	
		8	7	22.09	22.18	22.24	14.94	15.03	15.09	11.44	11.53	11.59	
		15	0	22.09	22.20	22.25	14.94	15.05	15.10	11.44	11.55	11.60	
5MHz	QPSK	1	0	25.04	25.00	25.13	17.89	17.85	17.98	14.39	14.35	14.48	
		1	13	25.00	25.00	25.12	17.85	17.85	17.97	14.35	14.35	14.47	
		1	24	24.96	24.96	25.04	17.81	17.81	17.89	14.31	14.31	14.39	
		12	0	24.02	24.07	24.14	16.87	16.92	16.99	13.37	13.42	13.49	
		12	6	24.08	24.13	24.21	16.93	16.98	17.06	13.43	13.48	13.56	
		12	13	24.07	24.12	24.18	16.92	16.97	17.03	13.42	13.47	13.53	
		25	0	24.10	24.13	24.21	16.95	16.98	17.06	13.45	13.48	13.56	
	16QAM	1	0	24.28	24.60	24.42	17.13	17.45	17.27	13.63	13.95	13.77	
		1	13	24.45	24.36	24.38	17.30	17.21	17.23	13.80	13.71	13.73	
		1	24	24.35	24.43	24.13	17.20	17.28	16.98	13.70	13.78	13.48	
		12	0	23.00	23.07	23.17	15.85	15.92	16.02	12.35	12.42	12.52	
		12	6	23.13	23.13	23.22	15.98	15.98	16.07	12.48	12.48	12.57	
		12	13	23.11	23.17	23.24	15.96	16.02	16.09	12.46	12.52	12.59	
		25	0	23.08	23.13	23.24	15.93	15.98	16.09	12.43	12.48	12.59	
	64QAM	1	0	23.29	23.35	23.26	16.14	16.20	16.11	12.64	12.70	12.61	
		1	13	23.29	23.36	23.37	16.14	16.21	16.22	12.64	12.71	12.72	
		1	24	23.41	23.26	23.31	16.26	16.11	16.16	12.76	12.61	12.66	
		12	0	22.02	22.09	22.16	14.87	14.94	15.01	11.37	11.44	11.51	
		12	6	22.11	22.16	22.26	14.96	15.01	15.11	11.46	11.51	11.61	
		12	13	22.07	22.14	22.21	14.92	14.99	15.06	11.42	11.49	11.56	
		25	0	22.07	22.16	22.20	14.92	15.01	15.05	11.42	11.51	11.55	
	10MHz	QPSK	1	0	25.01	24.96	25.10	17.86	17.81	17.95	14.36	14.31	14.45
			1	25	24.99	24.96	25.10	17.84	17.81	17.95	14.34	14.31	14.45
	1		49	24.94	24.95	25.01	17.79	17.80	17.86	14.29	14.30	14.36	
25	0		23.99	24.02	24.10	16.84	16.87	16.95	13.34	13.37	13.45		
25	13		24.06	24.09	24.18	16.91	16.94	17.03	13.41	13.44	13.53		
25	25		24.04	24.07	24.14	16.89	16.92	16.99	13.39	13.42	13.49		
50	0		24.07	24.08	24.17	16.92	16.93	17.02	13.42	13.43	13.52		
16QAM	1	0	24.25	24.56	24.37	17.10	17.41	17.22	13.60	13.91	13.72		



		1	25	24.42	24.34	24.34	17.27	17.19	17.19	13.77	13.69	13.69
		1	49	24.32	24.40	24.11	17.17	17.25	16.96	13.67	13.75	13.46
		25	0	22.97	23.03	23.14	15.82	15.88	15.99	12.32	12.38	12.49
		25	13	23.10	23.11	23.19	15.95	15.96	16.04	12.45	12.46	12.54
		25	25	23.08	23.12	23.20	15.93	15.97	16.05	12.43	12.47	12.55
		50	0	23.06	23.09	23.21	15.91	15.94	16.06	12.41	12.44	12.56
	64QAM	1	0	23.27	23.31	23.21	16.12	16.16	16.06	12.62	12.66	12.56
		1	25	23.25	23.34	23.33	16.10	16.19	16.18	12.60	12.69	12.68
		1	49	23.35	23.20	23.25	16.20	16.05	16.10	12.70	12.55	12.60
		25	0	21.97	22.01	22.09	14.82	14.86	14.94	11.32	11.36	11.44
		25	13	22.07	22.12	22.20	14.92	14.97	15.05	11.42	11.47	11.55
		25	25	22.04	22.09	22.17	14.89	14.94	15.02	11.39	11.44	11.52
		50	0	22.05	22.12	22.17	14.90	14.97	15.02	11.40	11.47	11.52

6.2. Occupied Bandwidth

Mode	Channel	Frequency (MHz)	99% Power Bandwidth (MHz)	-26dBc Bandwidth(MHz)
GSM 850 (GMSK)	128	824.2	0.245	0.306
	190	836.6	0.242	0.319
	251	848.8	0.244	0.316
GPRS 850 (GMSK)	128	824.2	0.243	0.312
	190	836.6	0.243	0.314
	251	848.8	0.248	0.314
EGPRS 850 (8PSK)	128	824.2	0.238	0.303
	190	836.6	0.247	0.304
	251	848.8	0.243	0.308
WCDMA Band V (RMC)	4132	826.4	4.134	4.703
	4183	836.6	4.150	4.707
	4233	846.6	4.151	4.694

LTE Band 5						
RB	Modulation	Bandwidth (MHz)	Channel	Frequency (MHz)	99% Power Bandwidth(MHz)	-26dBc Bandwidth(MHz)
100%	QPSK	1.4	20407	824.7	1.103	1.347
			20525	836.5	1.110	1.352
			20643	848.3	1.099	1.399
		3	20415	825.5	2.704	3.057
			20525	836.5	2.705	3.066
			20635	847.5	2.706	3.049
		5	20425	826.5	4.525	5.107
			20525	836.5	4.510	5.076
			20625	846.5	4.513	5.074
		10	20450	829	9.010	9.966
			20525	836.5	9.006	9.915
			20600	844	8.979	10.072
	16QAM	1.4	20407	824.7	1.107	1.355
			20525	836.5	1.106	1.357
			20643	848.3	1.105	1.331



		3	20415	825.5	2.702	3.027
			20525	836.5	2.706	3.007
			20635	847.5	2.712	3.088
		5	20425	826.5	4.515	5.055
			20525	836.5	4.513	5.086
			20625	846.5	4.539	5.142
		10	20450	829	8.992	9.926
			20525	836.5	8.990	9.930
			20600	844	8.986	9.906
	64QAM	1.4	20407	824.7	1.109	1.340
			20525	836.5	1.101	1.357
			20643	848.3	1.107	1.348
		3	20415	825.5	2.698	3.064
			20525	836.5	2.704	3.039
			20635	847.5	2.713	3.077
		5	20425	826.5	4.522	5.013
			20525	836.5	4.521	5.183
			20625	846.5	4.511	5.105
		10	20450	829	8.987	9.984
			20525	836.5	9.038	9.880
			20600	844	9.024	9.863

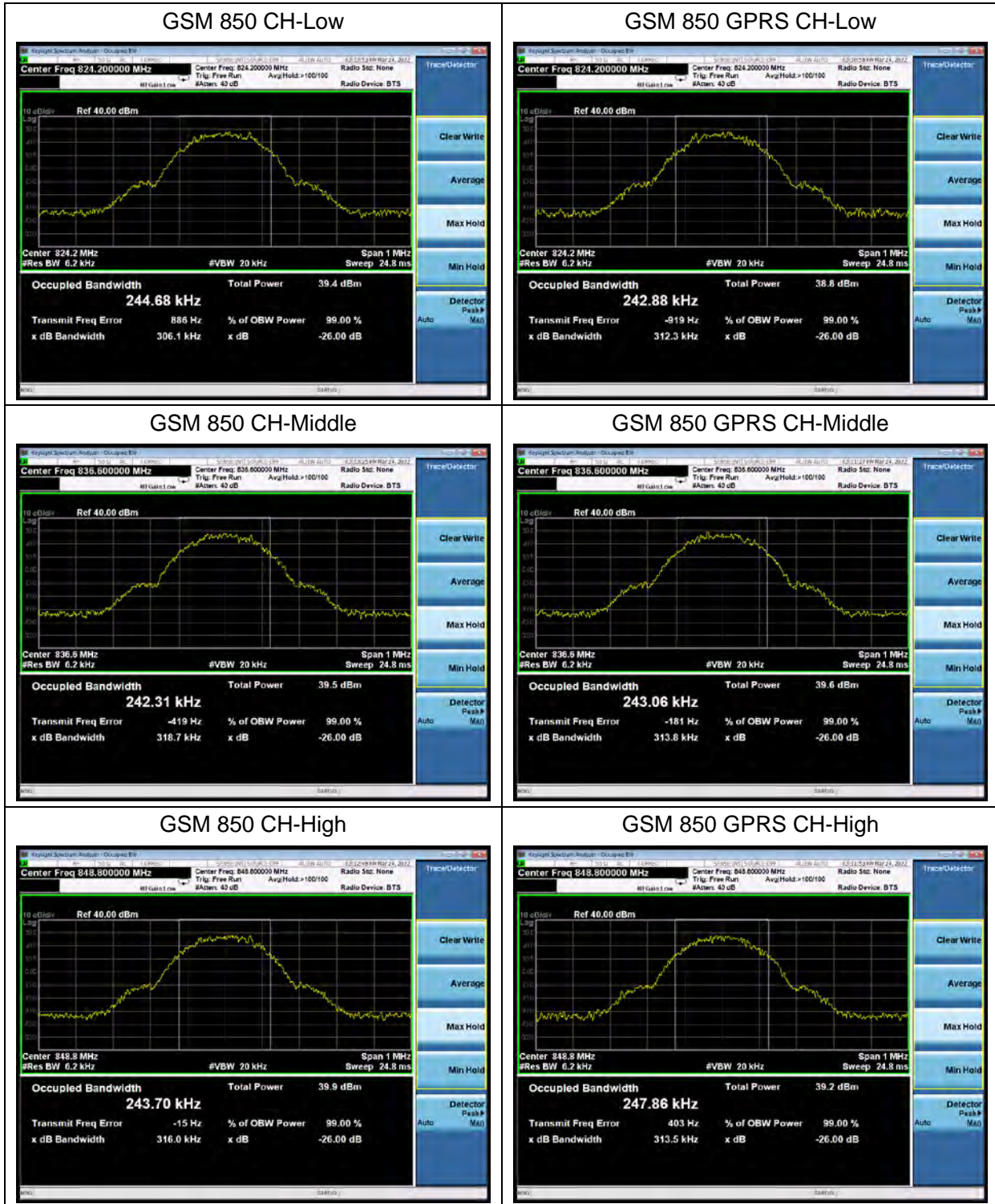

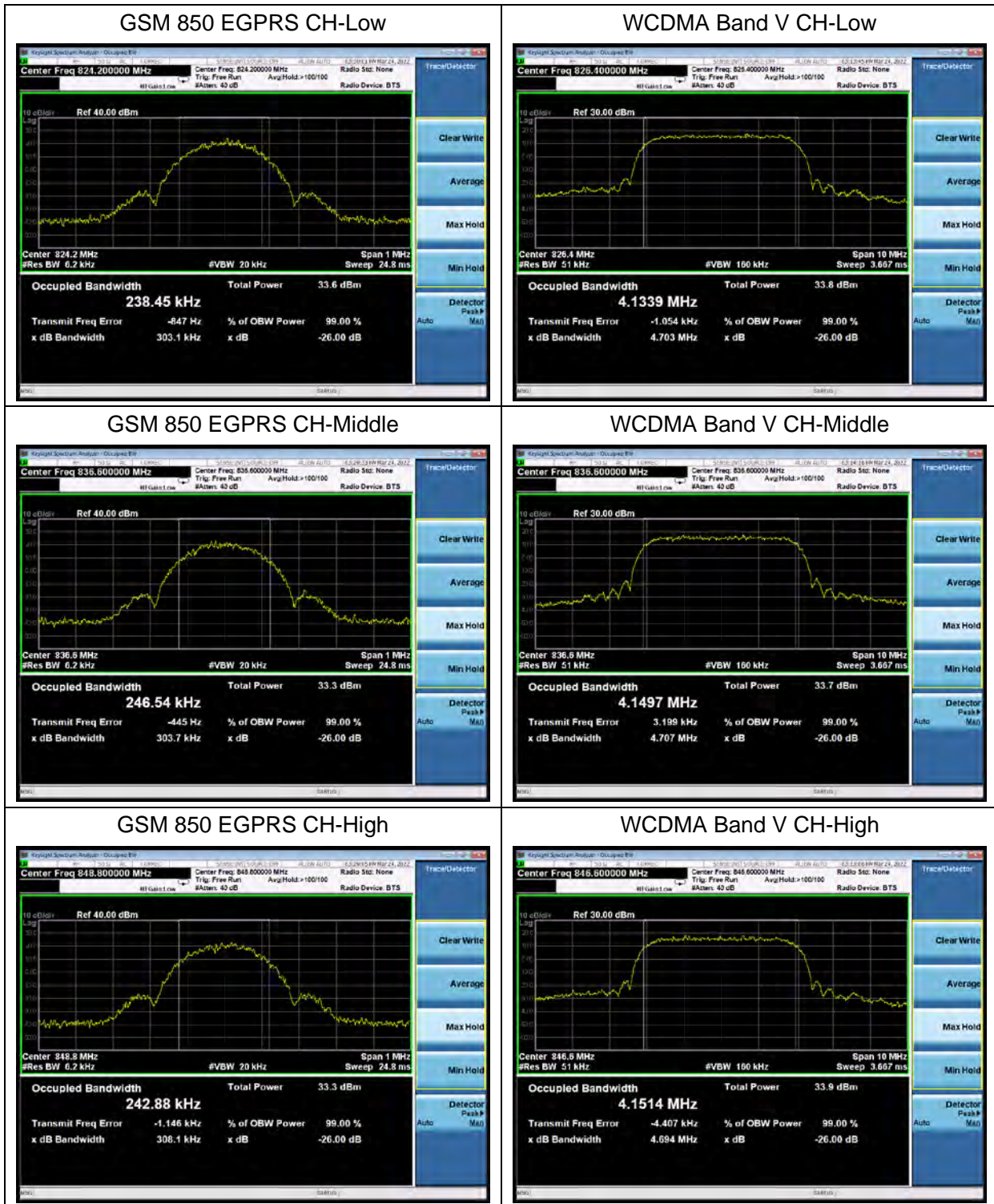

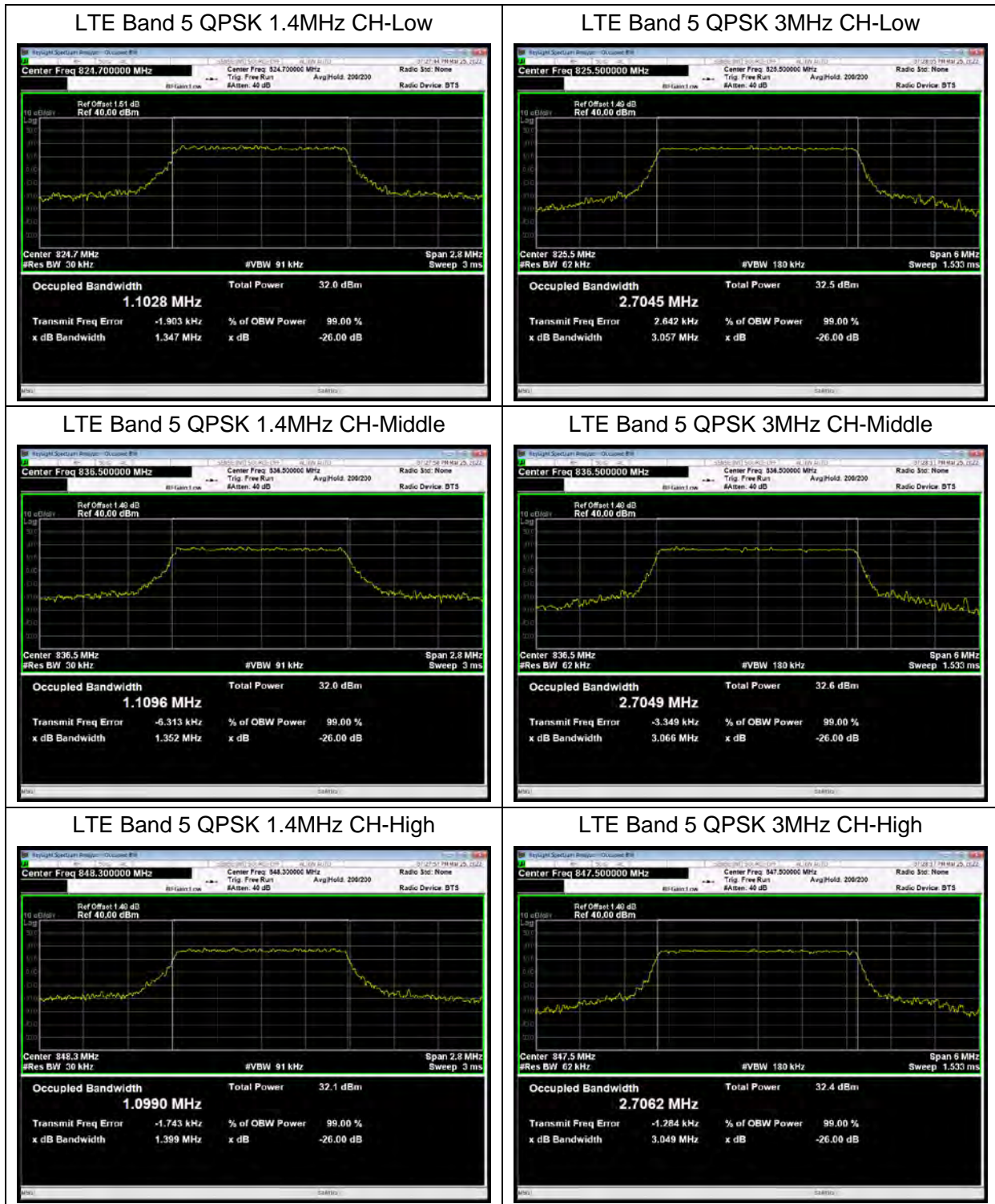

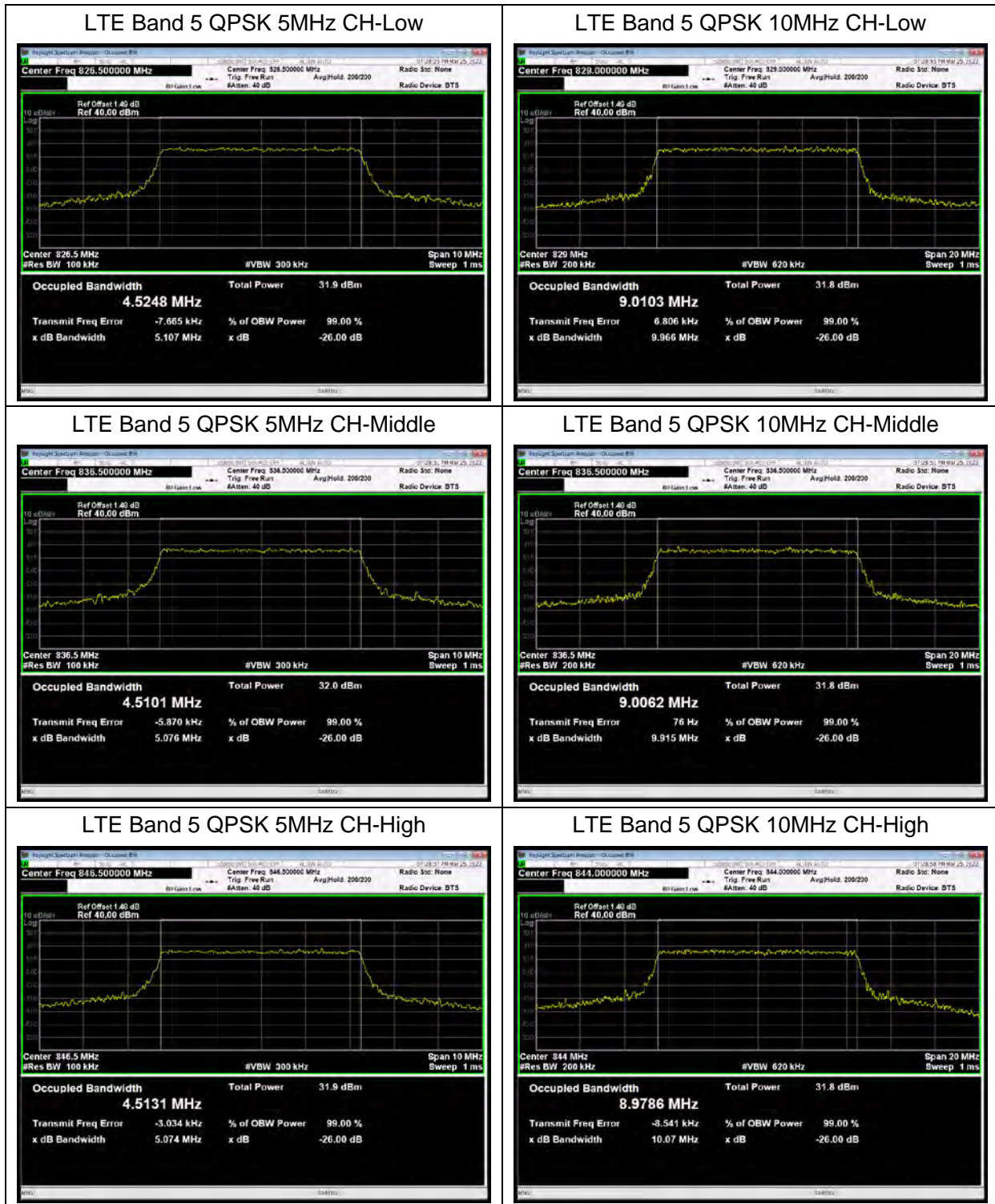

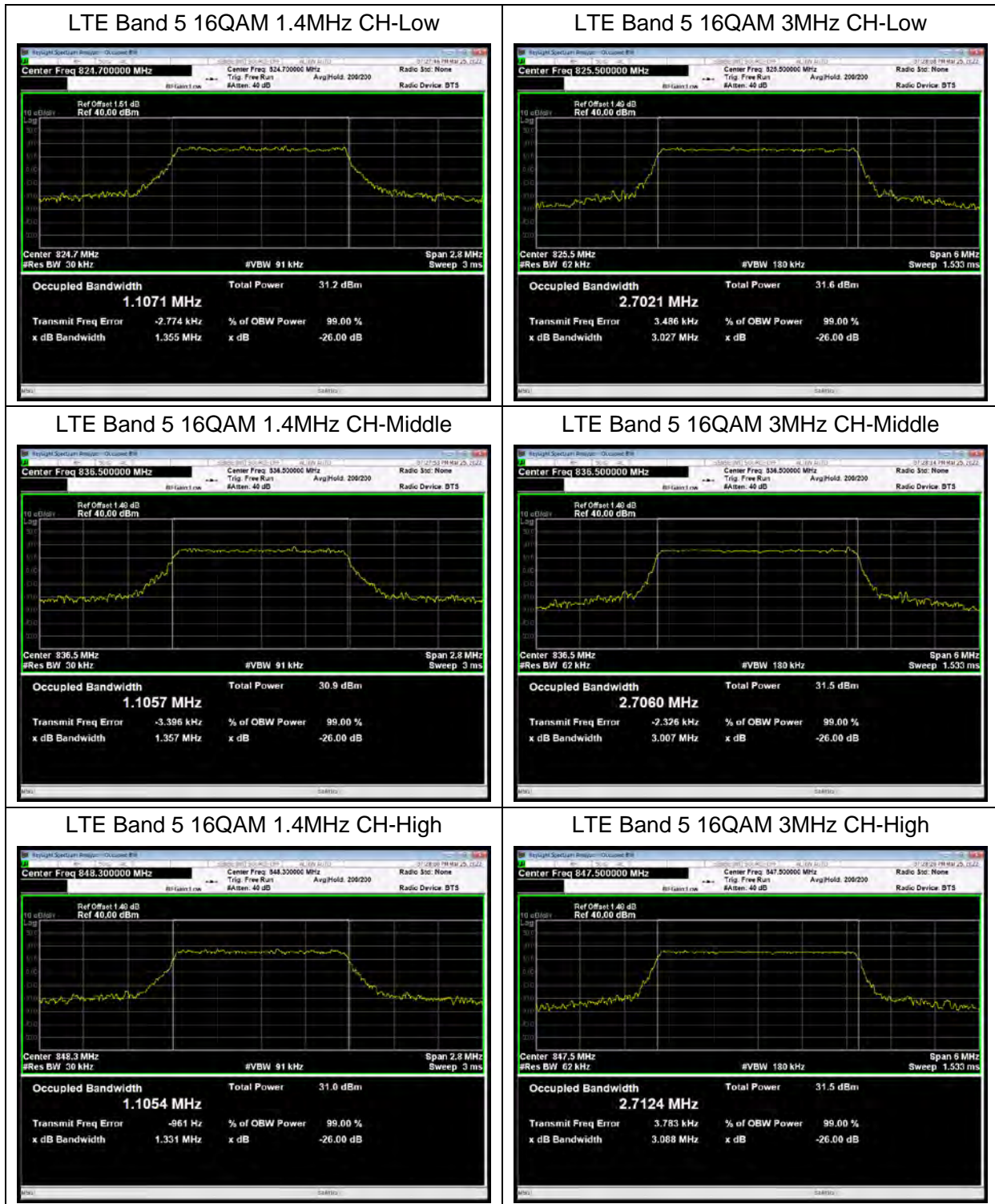

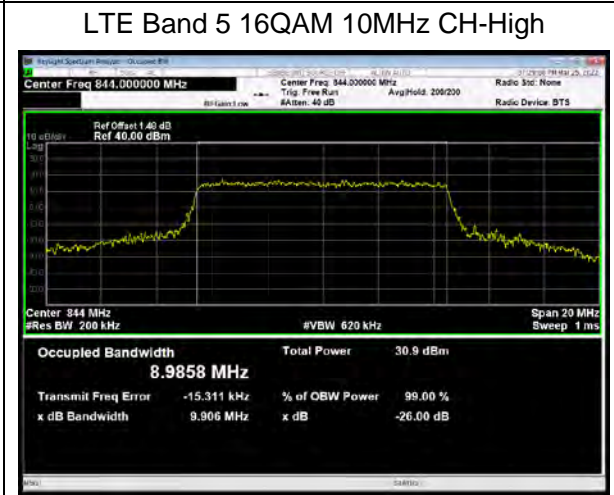
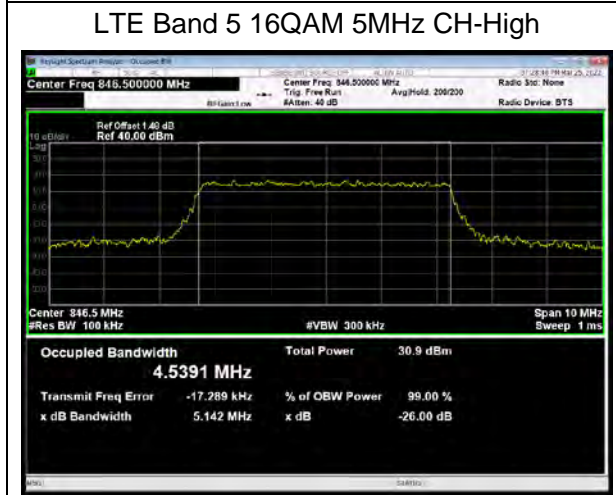
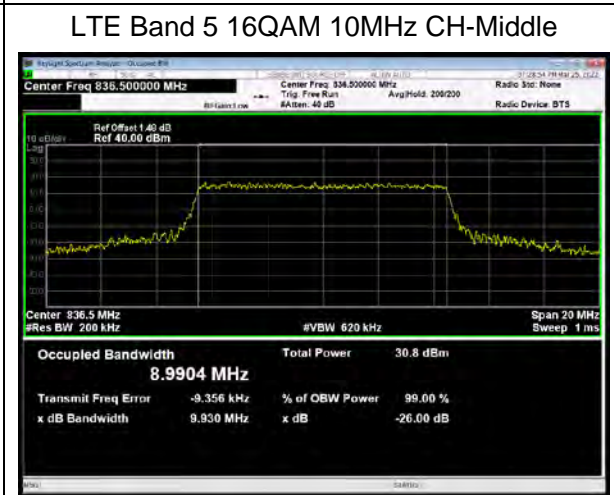
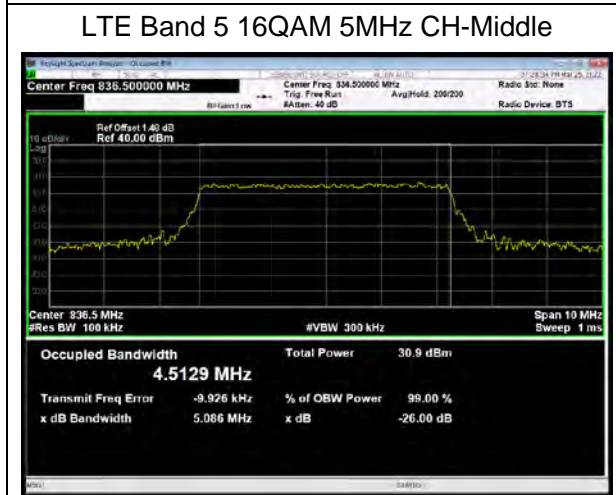
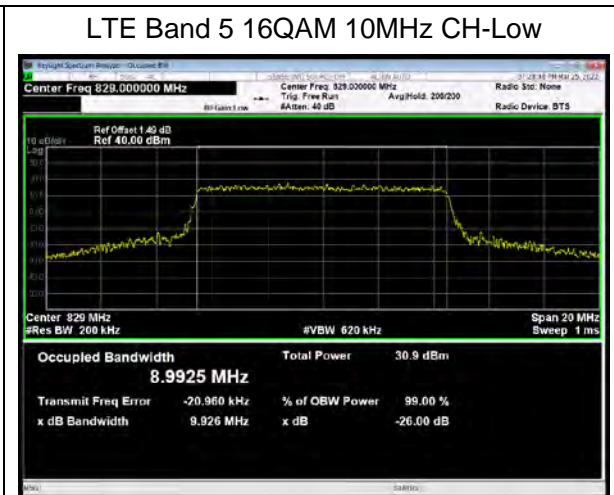
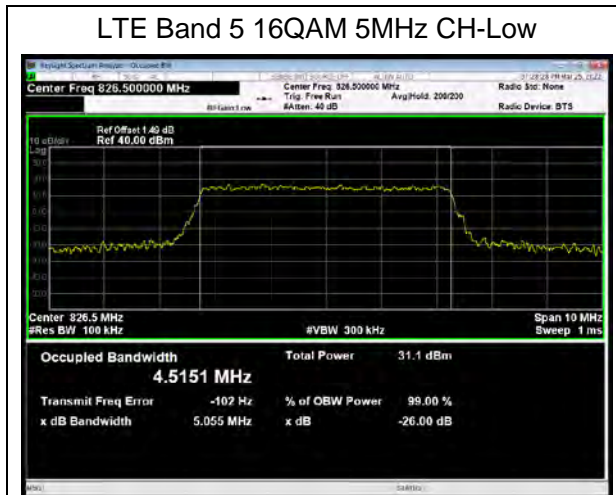

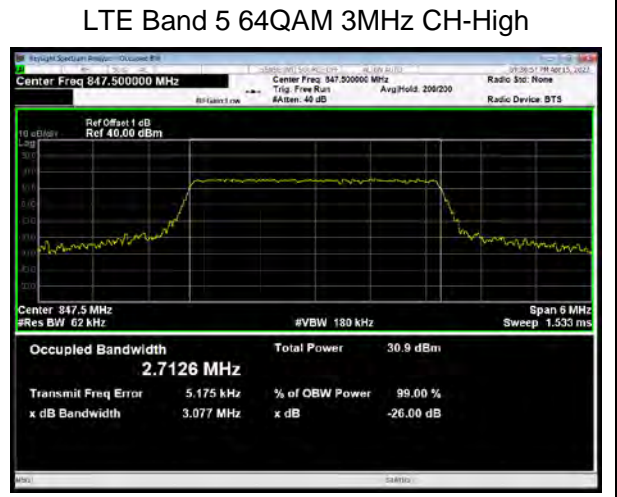
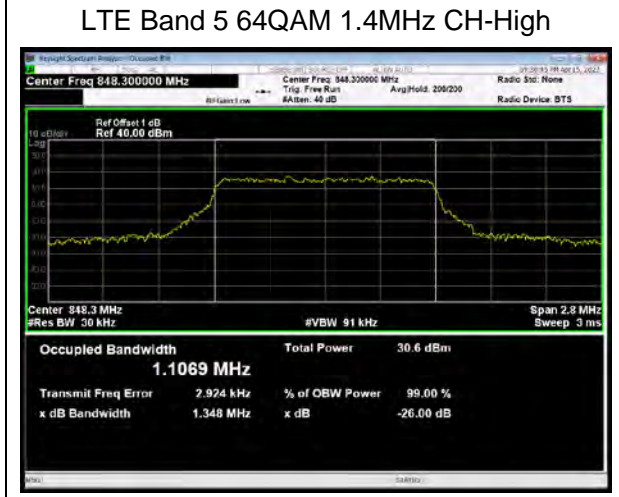
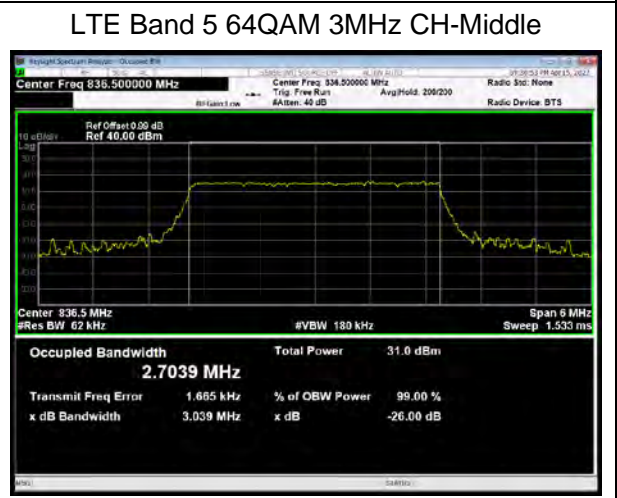
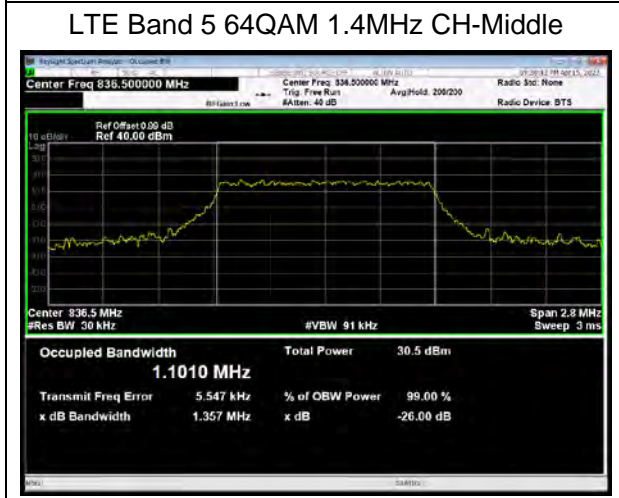
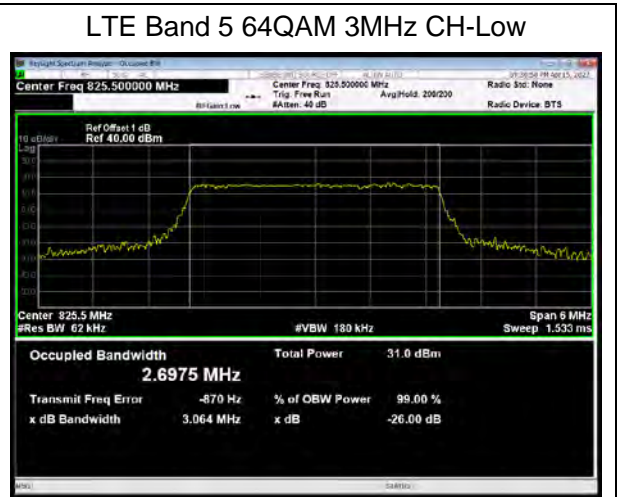
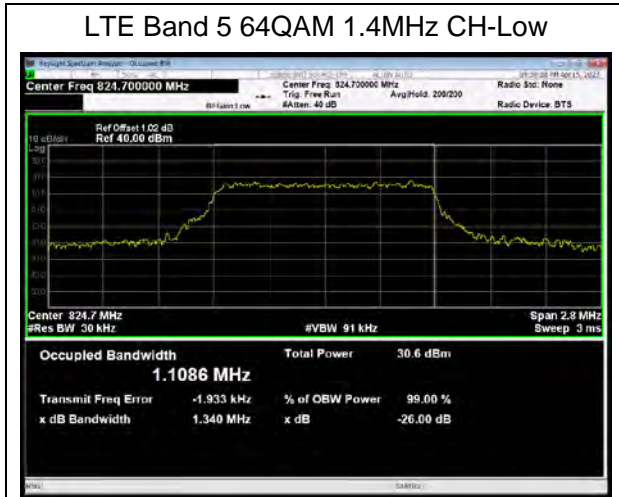

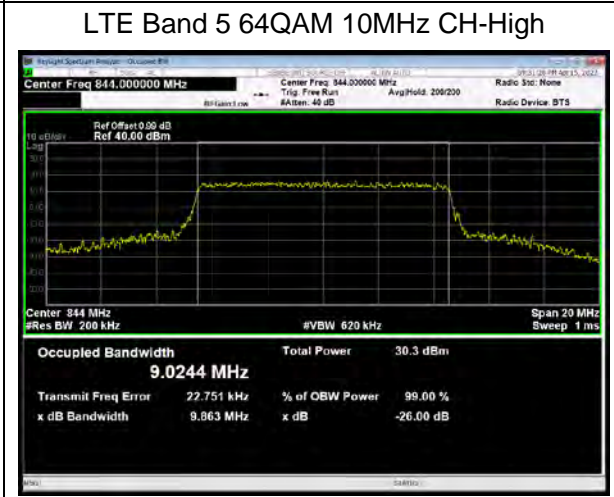
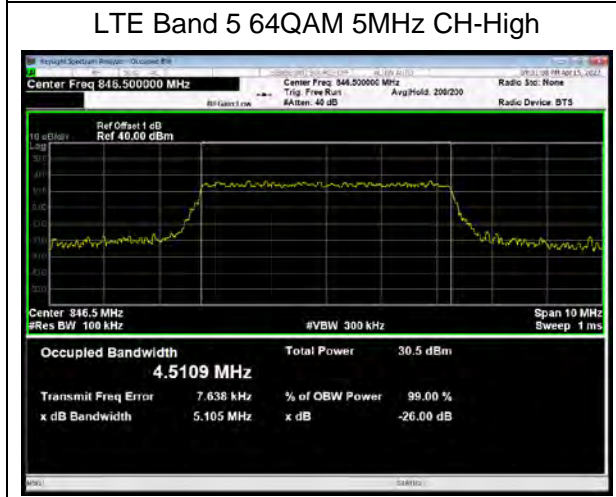
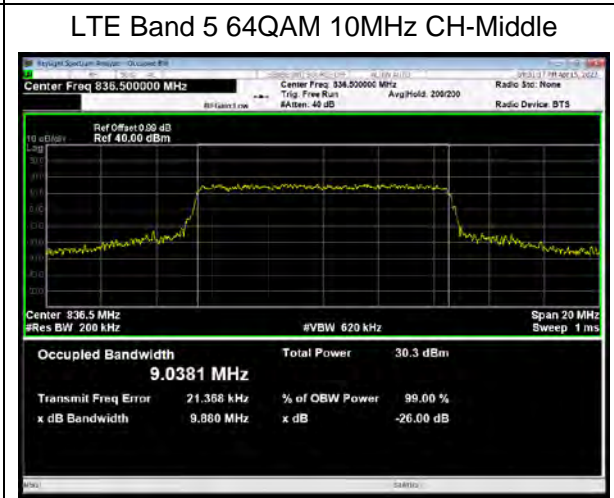
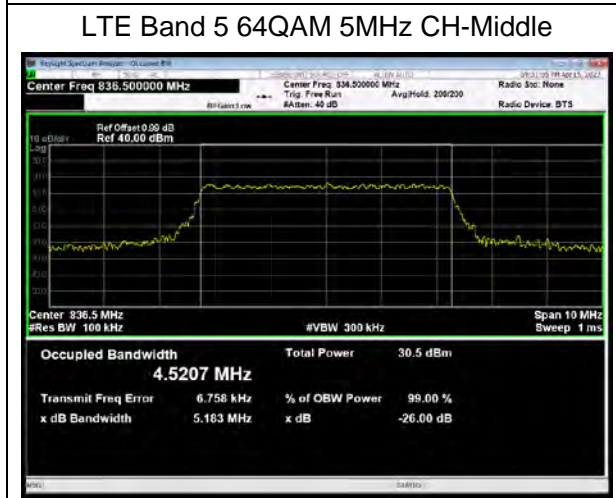
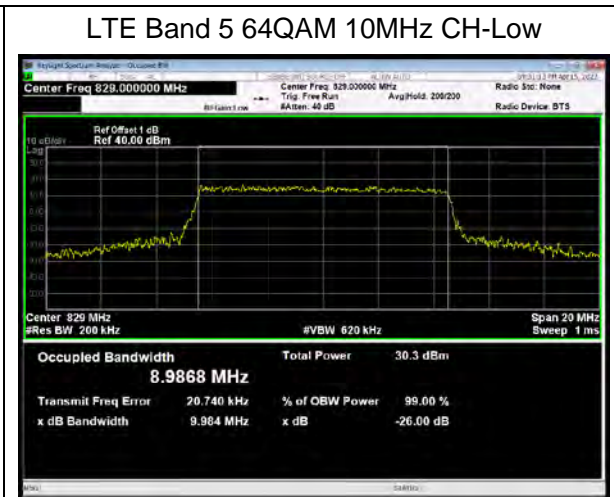
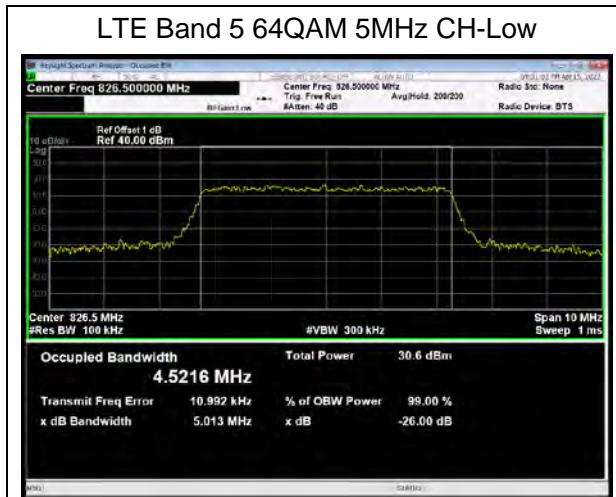

6.3. Band Edge Compliance

GSM 850 CH-Low

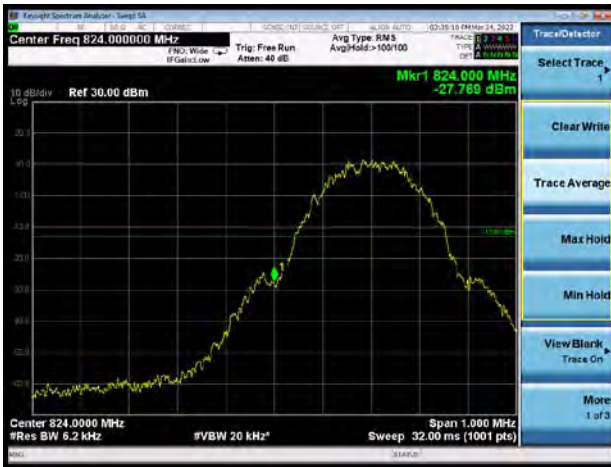

GSM 850 CH-High

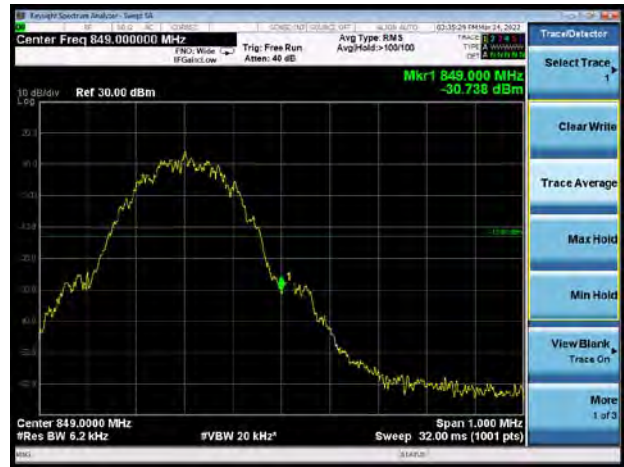

GSM 850 GPRS CH-Low

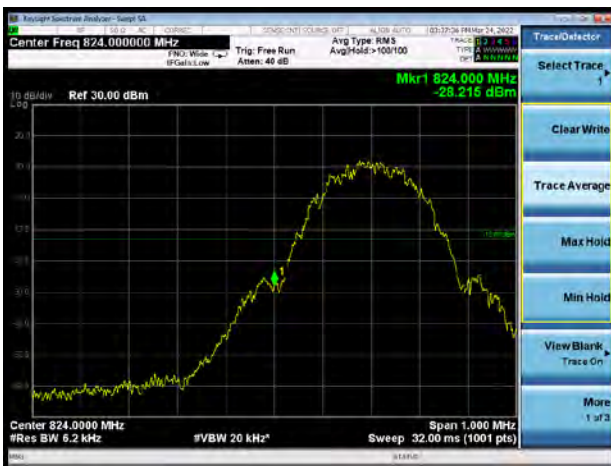

GSM 850 GPRS CH-High



GSM 850 EGPRS CH-Low



GSM 850 EGPRS CH-High





WCDMA Band V CH-Low



WCDMA Band V CH-High



LTE Band 5 QPSK 1.4MHz CH-Low 1RB

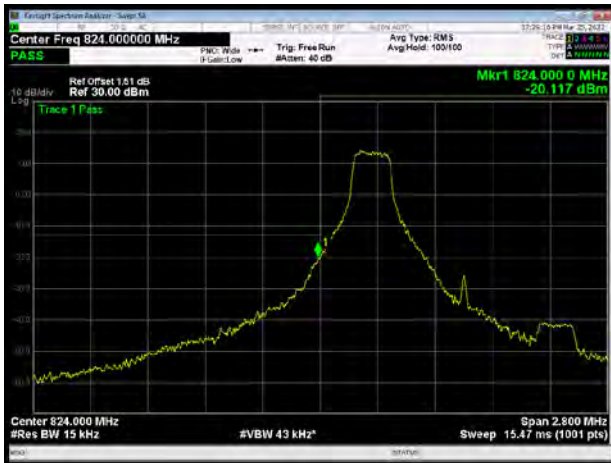

LTE Band 5 QPSK 1.4MHz CH-High 1RB

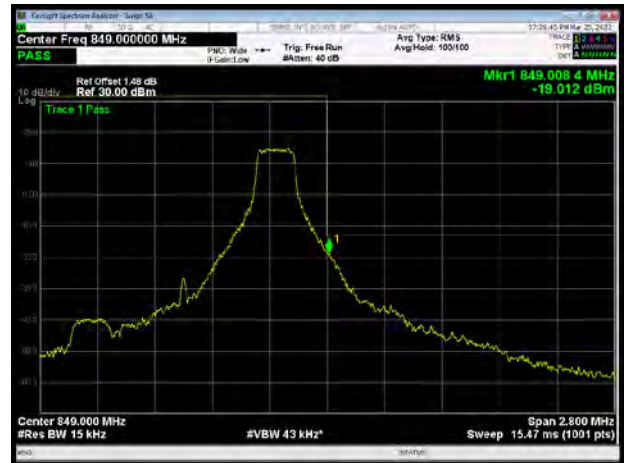

LTE Band 5 QPSK 1.4MHz CH-Low 100%RB

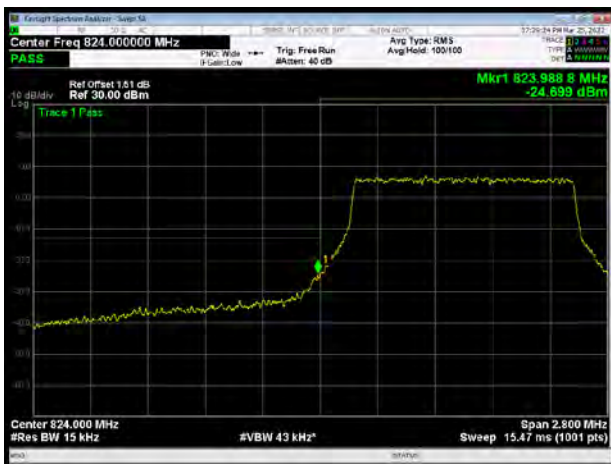

LTE Band 5 QPSK 1.4MHz CH-High 100%RB



LTE Band 5 QPSK 3MHz CH-Low 1RB



LTE Band 5 QPSK 3MHz CH-High 1RB

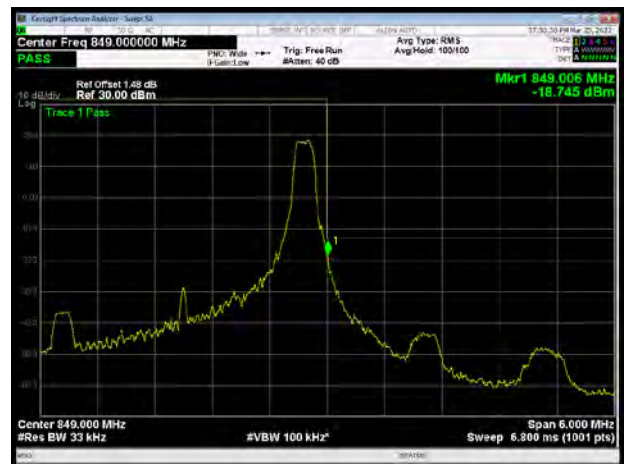

LTE Band 5 QPSK 3MHz CH-Low 100%RB



LTE Band 5 QPSK 3MHz CH-High 100%RB



LTE Band 5 QPSK 5MHz CH-Low 1RB

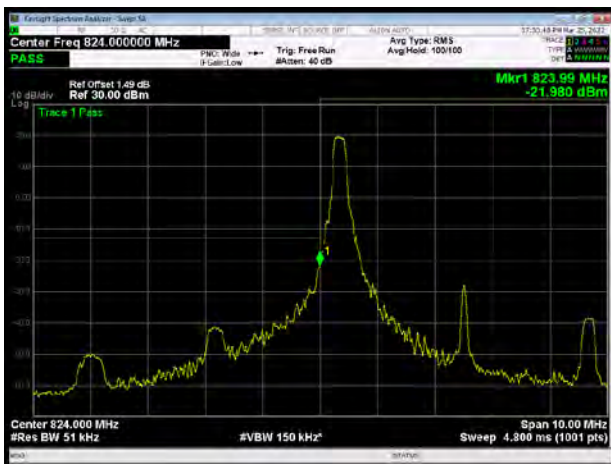

LTE Band 5 QPSK 5MHz CH-High 1RB

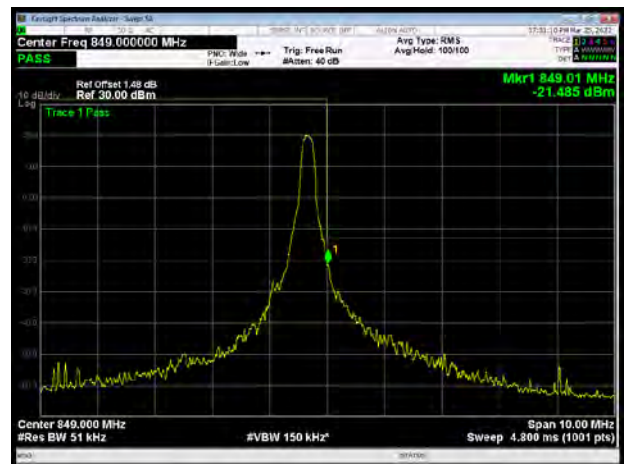

LTE Band 5 QPSK 5MHz CH-Low 100%RB

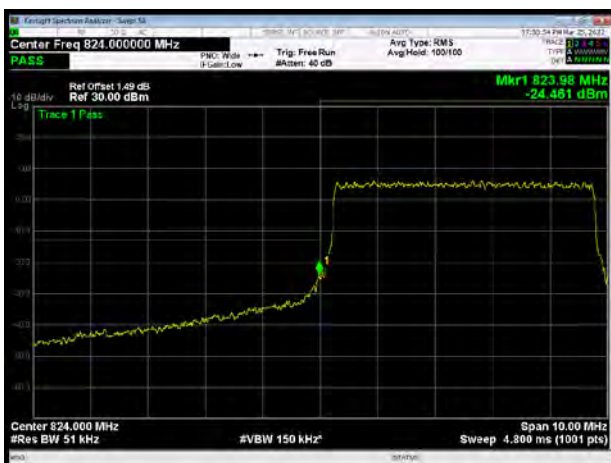

LTE Band 5 QPSK 5MHz CH-High 100%RB



LTE Band 5 QPSK 10MHz CH-Low 1RB

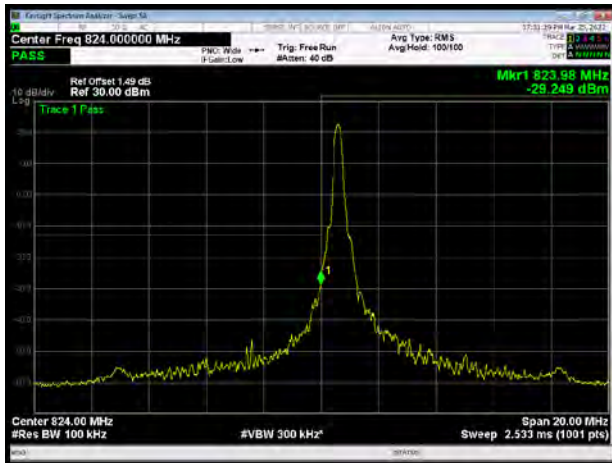

LTE Band 5 QPSK 10MHz CH-High 1RB

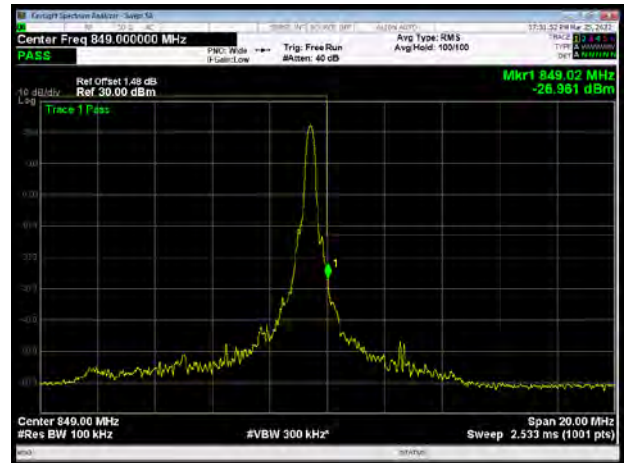

LTE Band 5 QPSK 10MHz CH-Low 100%RB

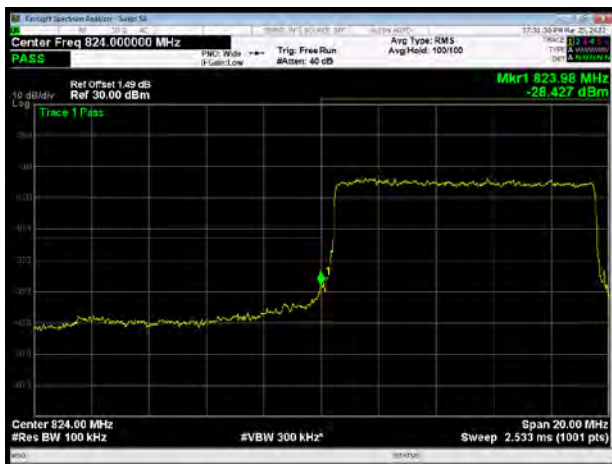

LTE Band 5 QPSK 10MHz CH-High 100%RB

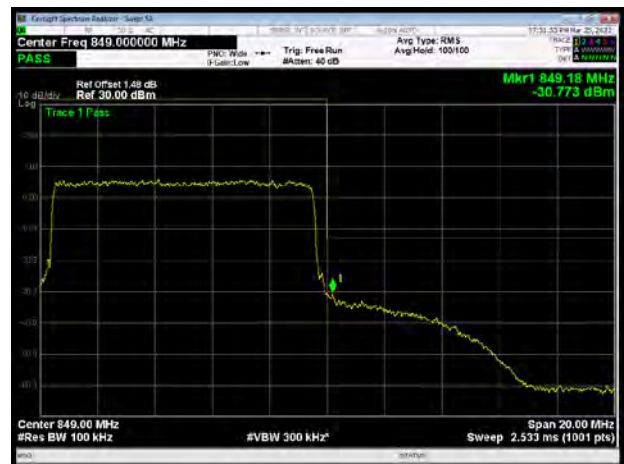

LTE Band 5 16QAM 1.4MHz CH-Low 1RB

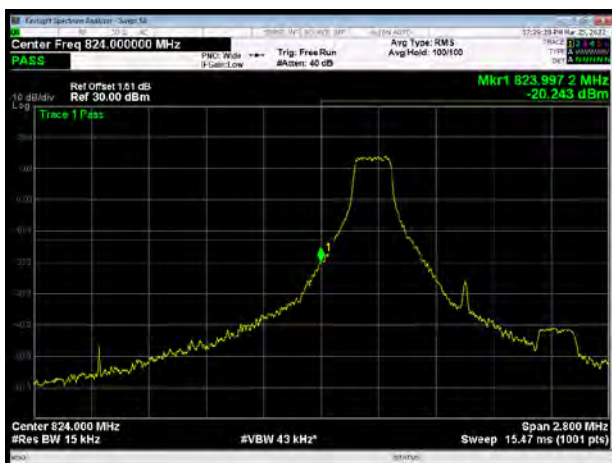

LTE Band 5 16QAM 1.4MHz CH-High 1RB

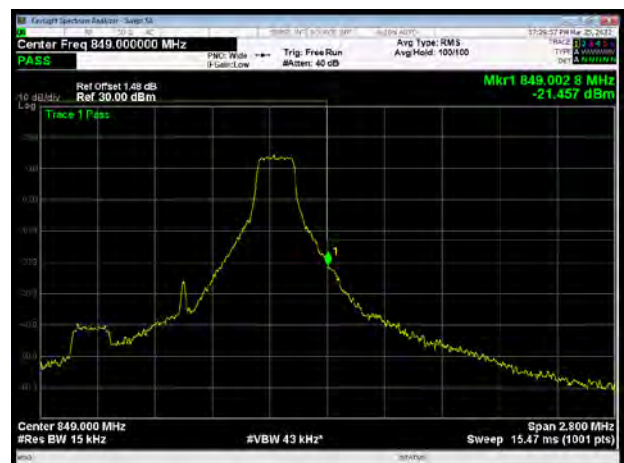



LTE Band 5 16QAM 1.4MHz CH-Low 100%RB

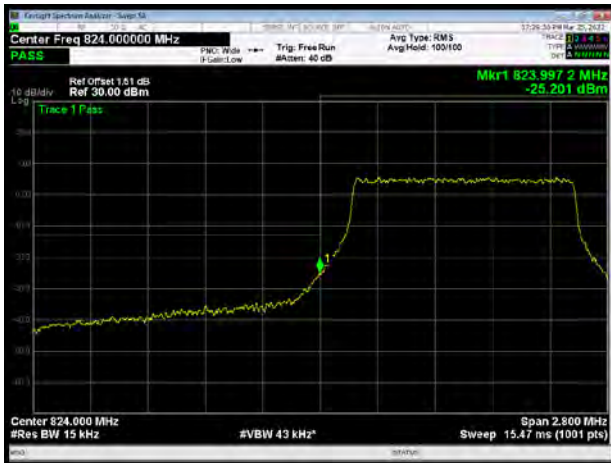

LTE Band 5 16QAM 1.4MHz CH-High 100%RB



LTE Band 5 16QAM 3MHz CH-Low 1RB

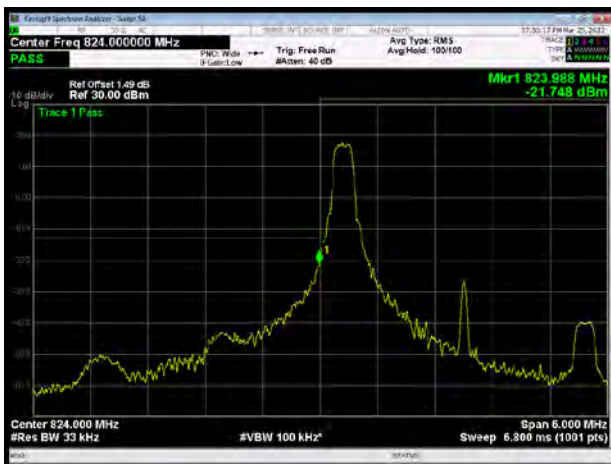

LTE Band 5 16QAM 3MHz CH-High 1RB

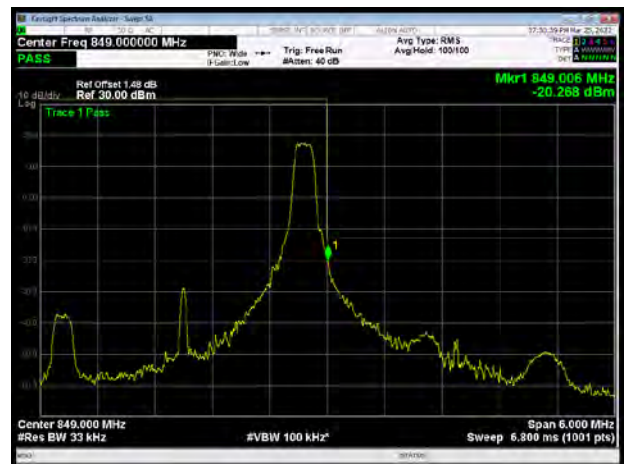

LTE Band 5 16QAM 3MHz CH-Low 100%RB

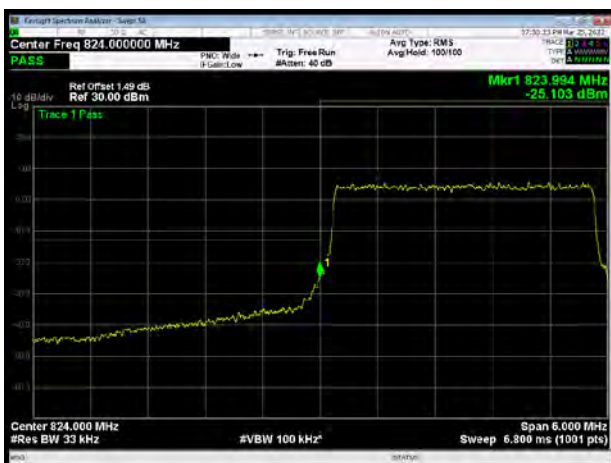

LTE Band 5 16QAM 3MHz CH-High 100%RB

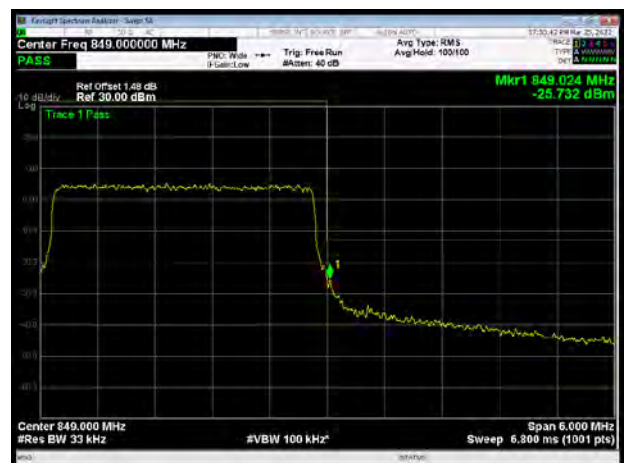

LTE Band 5 16QAM 5MHz CH-Low 1RB

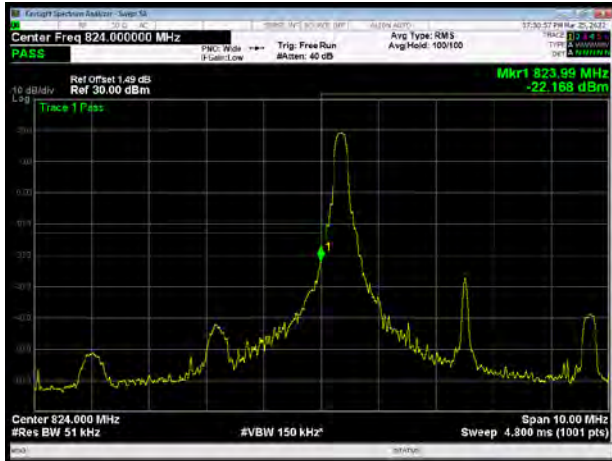

LTE Band 5 16QAM 5MHz CH-High 1RB

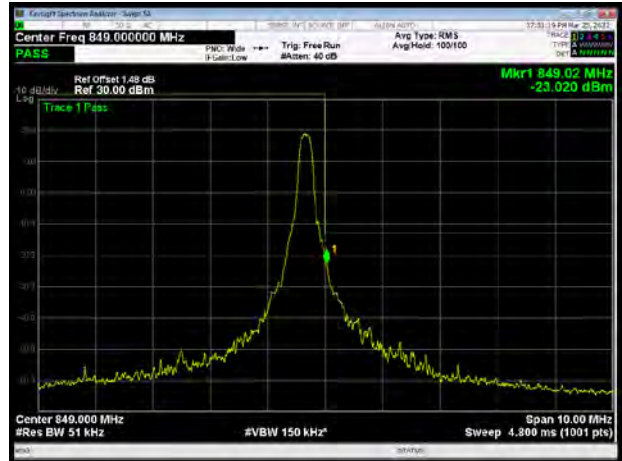

LTE Band 5 16QAM 5MHz CH-Low 100%RB

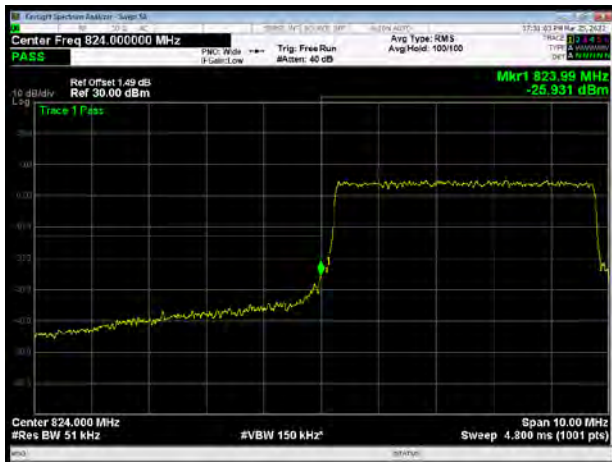

LTE Band 5 16QAM 5MHz CH-High 100%RB

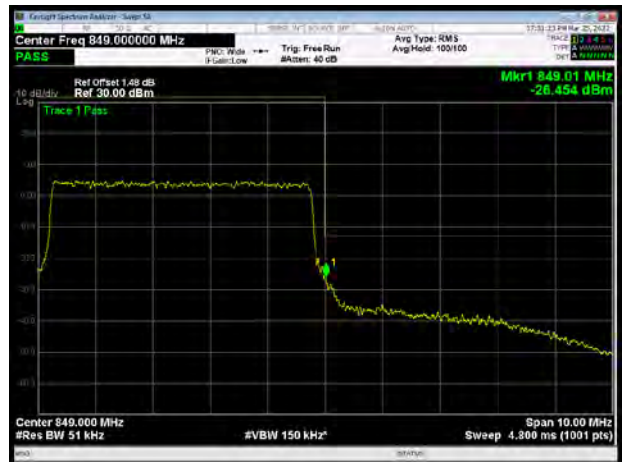

LTE Band 5 16QAM 10MHz CH-Low 1RB

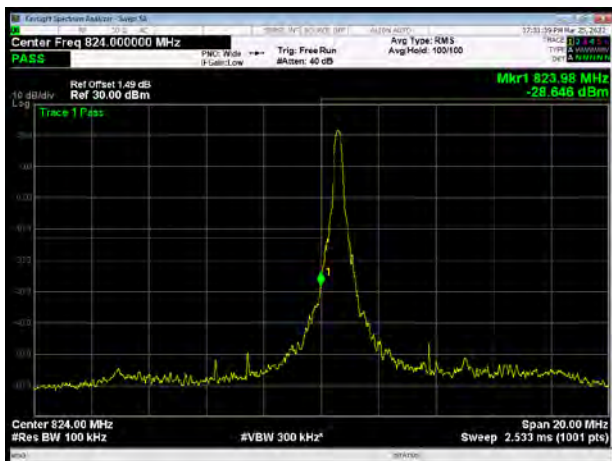

LTE Band 5 16QAM 10MHz CH-High 1RB

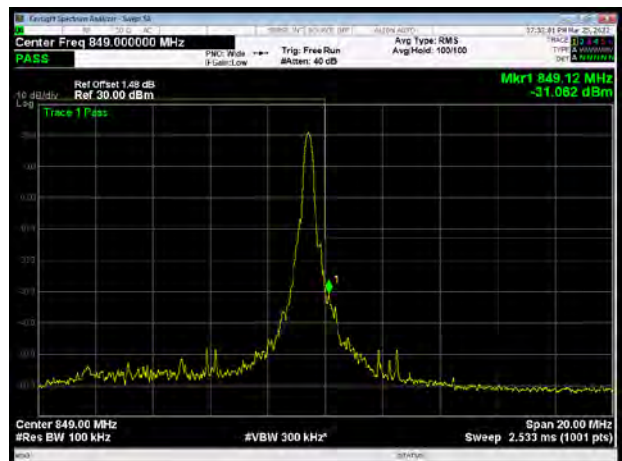

LTE Band 5 16QAM 10MHz CH-Low 100%RB

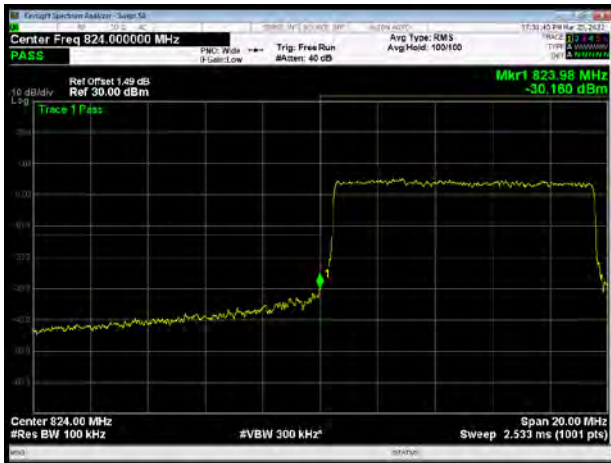

LTE Band 5 16QAM 10MHz CH-High 100%RB



LTE Band 5 64QAM 1.4MHz CH-Low 1RB

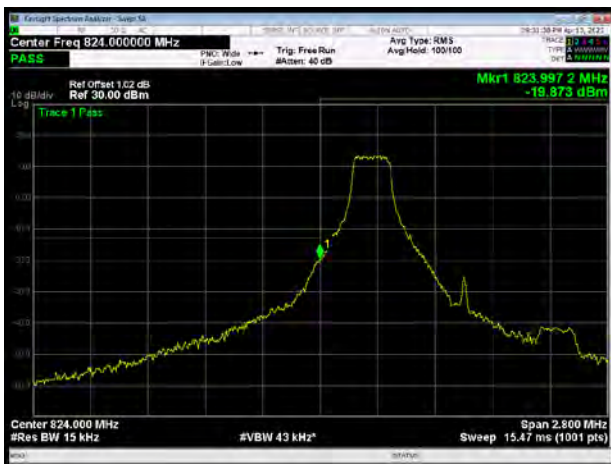

LTE Band 5 64QAM 1.4MHz CH-High 1RB

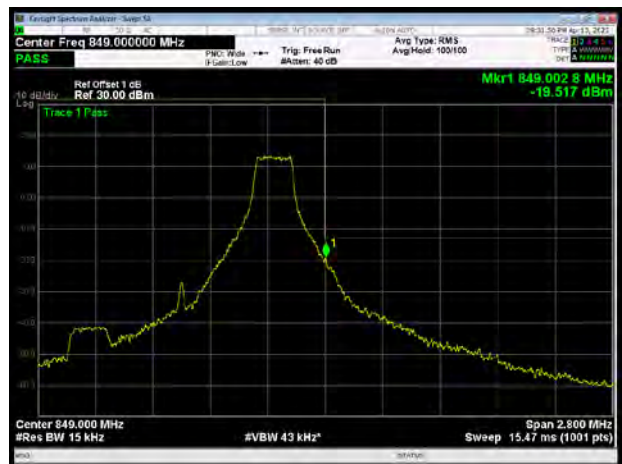

LTE Band 5 64QAM 1.4MHz CH-Low 100%RB

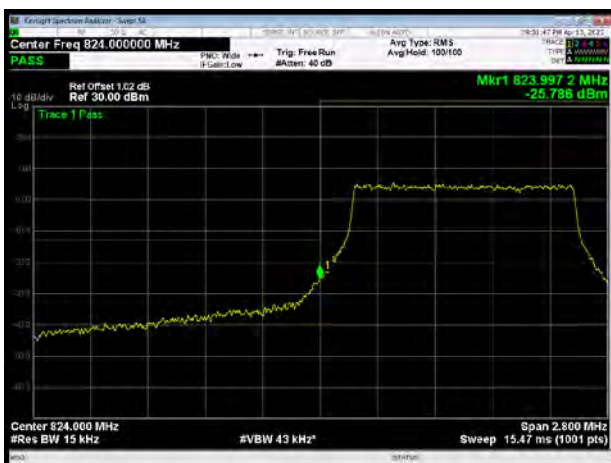

LTE Band 5 64QAM 1.4MHz CH-High 100%RB



LTE Band 5 64QAM 3MHz CH-Low 1RB

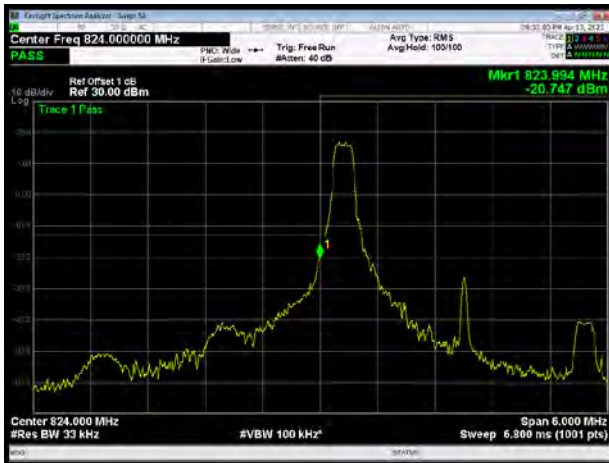

LTE Band 5 64QAM 3MHz CH-High 1RB

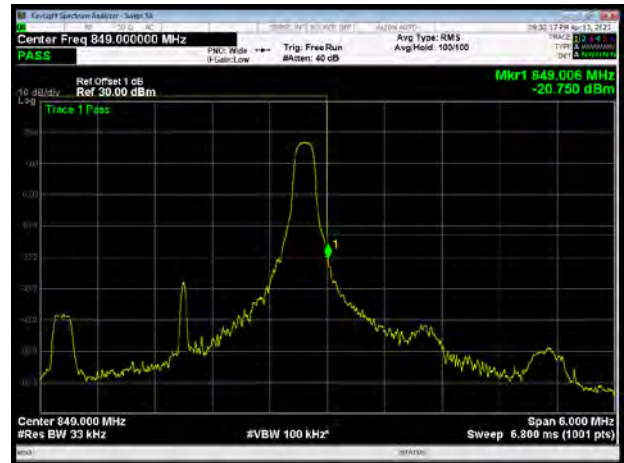

LTE Band 5 64QAM 3MHz CH-Low 100%RB

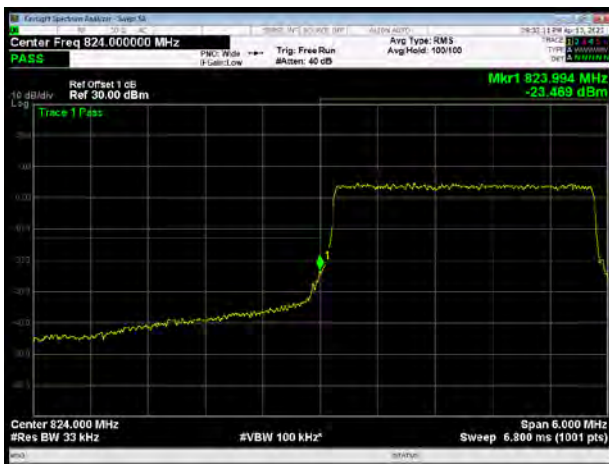

LTE Band 5 64QAM 3MHz CH-High 100%RB

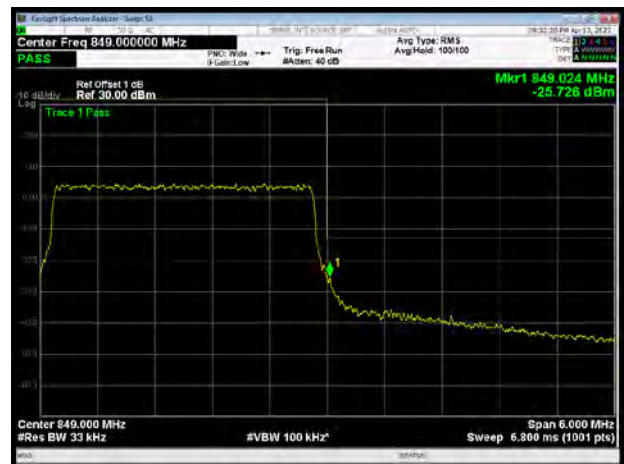

LTE Band 5 64QAM 5MHz CH-Low 1RB

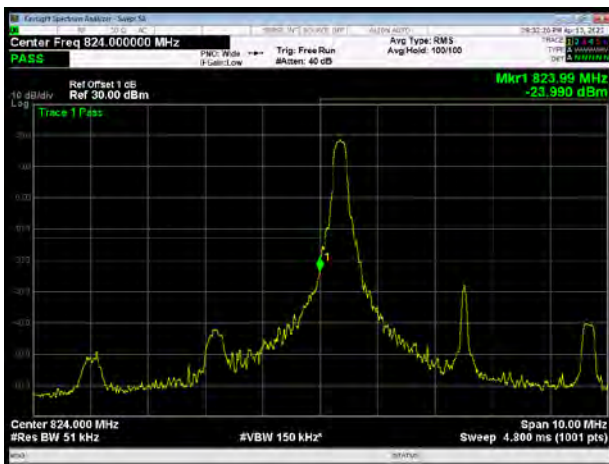

LTE Band 5 64QAM 5MHz CH-High 1RB

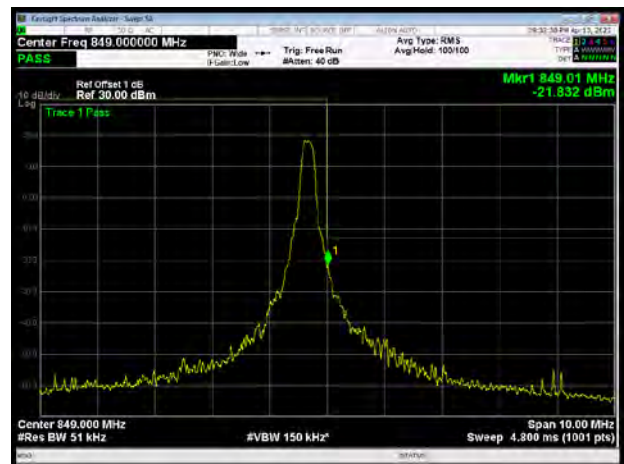



LTE Band 5 64QAM 5MHz CH-Low 100%RB

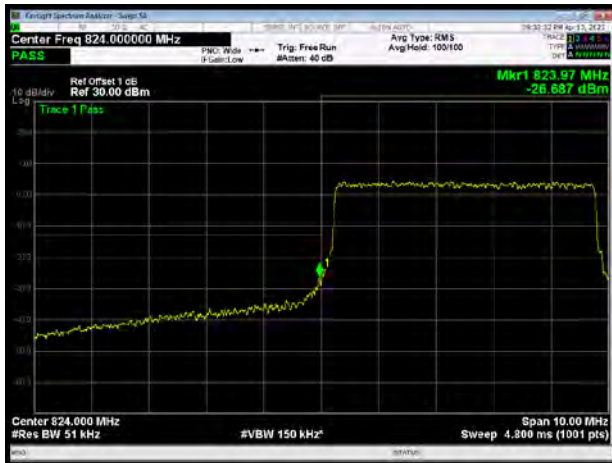

LTE Band 5 64QAM 5MHz CH-High 100%RB



LTE Band 5 64QAM 10MHz CH-Low 1RB

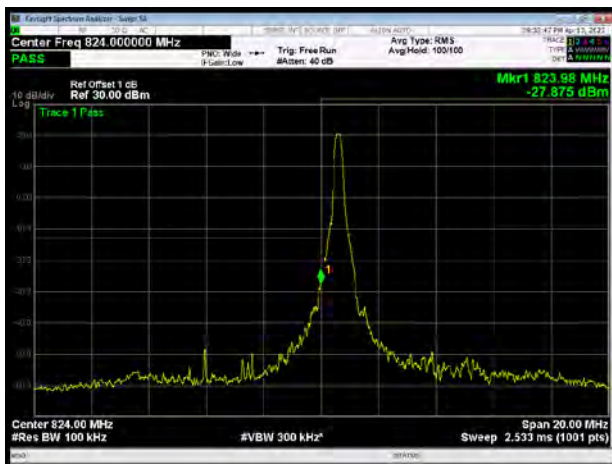

LTE Band 5 64QAM 10MHz CH-High 1RB

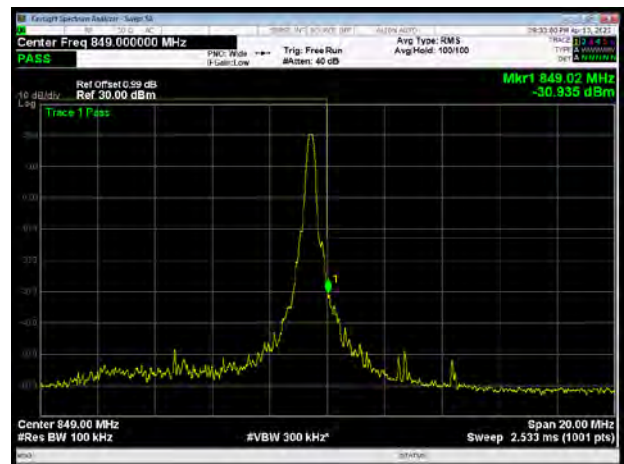

LTE Band 5 64QAM 10MHz CH-Low 100%RB



LTE Band 5 64QAM 10MHz CH-High 100%RB



6.4. Peak-to-Average Power Ratio (PAPR)

Mode	Channel	Frequency (MHz)	Peak (dBm)	Avg (dBm)	PAPR (dB)	Limit (dB)	Conclusion
GSM 850 (GMSK)	128	824.2	33.23	30.27	2.96	≤13	PASS
	190	836.6	33.59	30.61	2.98	≤13	PASS
	251	848.8	33.54	30.58	2.96	≤13	PASS
GPRS 850 (GMSK)	128	824.2	33.32	30.36	2.96	≤13	PASS
	190	836.6	33.62	30.65	2.97	≤13	PASS
	251	848.8	33.59	30.62	2.97	≤13	PASS
EGPRS 850 (8PSK)	128	824.2	30.53	24.54	5.99	≤13	PASS
	190	836.6	30.60	24.70	5.90	≤13	PASS
	251	848.8	30.66	24.66	6.00	≤13	PASS
WCDMA Band V (RMC)	4132	826.4	27.89	25.15	2.74	≤13	PASS
	4183	836.6	27.90	25.17	2.73	≤13	PASS
	4233	846.6	28.04	25.24	2.80	≤13	PASS

LTE Band 5								
Modulation	Bandwidth (MHz)	Channel	Frequency (MHz)	Peak (dBm)	Avg (dBm)	PAPR (dB)	Limit (dB)	Conclusion
QPSK	1.4	20407	824.7	28.28	23.89	4.39	≤13	PASS
		20525	836.5	28.28	23.88	4.40	≤13	PASS
		20643	848.3	28.23	23.91	4.32	≤13	PASS
	3	20415	825.5	28.35	23.92	4.43	≤13	PASS
		20525	836.5	28.34	23.91	4.43	≤13	PASS
		20635	847.5	28.30	23.89	4.41	≤13	PASS
	5	20425	826.5	28.37	23.94	4.43	≤13	PASS
		20525	836.5	28.39	23.95	4.44	≤13	PASS
		20625	846.5	28.36	23.89	4.47	≤13	PASS
	10	20450	829	28.62	23.99	4.63	≤13	PASS
		20525	836.5	28.65	23.98	4.67	≤13	PASS
		20600	844	28.73	24.00	4.73	≤13	PASS
16QAM	1.4	20407	824.7	28.22	22.90	5.32	≤13	PASS
		20525	836.5	28.31	22.91	5.40	≤13	PASS
		20643	848.3	28.21	22.91	5.30	≤13	PASS
	3	20415	825.5	28.26	22.91	5.35	≤13	PASS



		20525	836.5	28.32	22.93	5.39	≤13	PASS
		20635	847.5	28.27	22.86	5.41	≤13	PASS
	5	20425	826.5	28.36	22.98	5.38	≤13	PASS
		20525	836.5	28.38	22.96	5.42	≤13	PASS
		20625	846.5	28.38	22.90	5.48	≤13	PASS
	10	20450	829	28.54	22.99	5.55	≤13	PASS
		20525	836.5	28.56	22.99	5.57	≤13	PASS
		20600	844	28.70	23.01	5.69	≤13	PASS
64QAM	1.4	20407	824.7	27.74	22.39	5.35	≤13	PASS
		20525	836.5	27.68	22.36	5.32	≤13	PASS
		20643	848.3	27.67	22.37	5.30	≤13	PASS
	3	20415	825.5	27.73	22.41	5.32	≤13	PASS
		20525	836.5	27.76	22.38	5.38	≤13	PASS
		20635	847.5	27.69	22.32	5.37	≤13	PASS
	5	20425	826.5	27.81	22.42	5.39	≤13	PASS
		20525	836.5	27.79	22.40	5.39	≤13	PASS
		20625	846.5	27.82	22.36	5.46	≤13	PASS
	10	20450	829	27.99	22.44	5.55	≤13	PASS
		20525	836.5	27.97	22.41	5.56	≤13	PASS
		20600	844	28.12	22.44	5.68	≤13	PASS

6.5. Frequency Stability

GSM850						
Condition		Freq.Error (Hz)	Freq.Error (Hz)	Frequency Stability (ppm)	Frequency Stability (ppm)	Verdict
Temperature	Voltage	GMSK	8PSK	GMSK	8PSK	
Normal (25°C)	Normal	17.40	11.79	0.02080	0.01409	PASS
Extreme (50°C)		7.93	5.21	0.00948	0.00622	PASS
Extreme (40°C)		11.42	14.97	0.01365	0.01789	PASS
Extreme (30°C)		2.38	4.54	0.00285	0.00542	PASS
Extreme (20°C)		5.98	7.52	0.00714	0.00899	PASS
Extreme (10°C)		17.15	16.30	0.02050	0.01948	PASS
Extreme (0°C)		6.68	14.43	0.00799	0.01725	PASS
Extreme (-10°C)		17.64	9.38	0.02108	0.01122	PASS
Extreme (-20°C)		12.12	6.10	0.01449	0.00730	PASS
Extreme (-30°C)		4.81	12.62	0.00575	0.01509	PASS
25°C	LV	12.08	5.49	0.01443	0.00656	PASS
	HV	4.28	16.33	0.00511	0.01952	PASS

WCDMA Band5						
Condition		Freq.Error (Hz)	Freq.Error (Hz)	Frequency Stability (ppm)	Frequency Stability (ppm)	Verdict
Temperature	Voltage	BPSK	QPSK	BPSK	QPSK	
Normal (25°C)	Normal	13.76	14.75	0.01645	0.01763	PASS
Extreme (50°C)		12.21	10.91	0.01459	0.01304	PASS
Extreme (40°C)		12.72	15.16	0.01520	0.01812	PASS
Extreme (30°C)		12.00	10.98	0.01434	0.01313	PASS
Extreme (20°C)		6.42	8.13	0.00767	0.00972	PASS
Extreme (10°C)		1.11	4.70	0.00132	0.00562	PASS
Extreme (0°C)		14.88	16.21	0.01778	0.01938	PASS
Extreme (-10°C)		7.51	8.06	0.00897	0.00963	PASS
Extreme (-20°C)		10.19	14.51	0.01218	0.01735	PASS
Extreme (-30°C)		4.38	14.05	0.00524	0.01680	PASS
25°C	LV	8.39	14.09	0.01003	0.01685	PASS
	HV	9.74	1.38	0.01164	0.00165	PASS



LTE Band 5								
Condition		Freq.Error (Hz)	Freq.Error (Hz)	Freq.Error (Hz)	Frequency Stability (ppm)	Frequency Stability (ppm)	Frequency Stability (ppm)	Verdict
BANDWIDTH	1.4MHz							
Temperature	Voltage	64QAM	16QAM	QPSK	64QAM	16QAM	QPSK	
Normal (25°C)	Normal	14.88	15.96	6.13	0.01778	0.01908	0.00733	PASS
Extreme (50°C)		17.01	9.17	1.01	0.02034	0.01096	0.00121	PASS
Extreme (40°C)		9.99	9.49	1.88	0.01194	0.01134	0.00225	PASS
Extreme (30°C)		12.57	16.41	14.64	0.01503	0.01961	0.01751	PASS
Extreme (20°C)		3.78	4.60	16.47	0.00452	0.00550	0.01968	PASS
Extreme (10°C)		5.83	4.37	6.51	0.00697	0.00523	0.00778	PASS
Extreme (0°C)		4.83	8.15	12.79	0.00578	0.00974	0.01529	PASS
Extreme (-10°C)		13.90	17.35	6.87	0.01661	0.02074	0.00821	PASS
Extreme (-20°C)		7.29	8.87	6.92	0.00872	0.01060	0.00827	PASS
Extreme (-30°C)		1.22	12.00	17.62	0.00146	0.01435	0.02106	PASS
25°C	LV	14.97	10.00	6.68	0.01790	0.01196	0.00798	PASS
	HV	2.60	9.93	3.06	0.00310	0.01187	0.00365	PASS
Condition		Freq.Error (Hz)	Freq.Error (Hz)	Freq.Error (Hz)	Frequency Stability (ppm)	Frequency Stability (ppm)	Frequency Stability (ppm)	Verdict
BANDWIDTH	3MHz							
Temperature	Voltage	64QAM	16QAM	QPSK	64QAM	16QAM	QPSK	
Normal (25°C)	Normal	7.65	1.92	7.55	0.00915	0.00229	0.00902	PASS
Extreme (50°C)		10.06	15.43	3.14	0.01202	0.01845	0.00375	PASS
Extreme (40°C)		5.63	16.31	6.81	0.00673	0.01949	0.00815	PASS
Extreme (30°C)		10.74	15.71	11.82	0.01284	0.01879	0.01413	PASS
Extreme (20°C)		11.56	2.38	3.59	0.01383	0.00285	0.00429	PASS
Extreme (10°C)		3.55	5.22	14.58	0.00424	0.00624	0.01743	PASS
Extreme (0°C)		2.09	13.28	2.39	0.00250	0.01587	0.00285	PASS
Extreme (-10°C)		5.25	16.68	3.06	0.00627	0.01994	0.00365	PASS
Extreme (-20°C)		11.24	2.15	14.50	0.01344	0.00256	0.01733	PASS
Extreme (-30°C)		4.64	5.59	16.50	0.00555	0.00668	0.01972	PASS
25°C	LV	12.60	9.07	9.26	0.01506	0.01084	0.01106	PASS
	HV	8.87	13.97	2.66	0.01061	0.01670	0.00318	PASS
Condition		Freq.Error (Hz)	Freq.Error (Hz)	Freq.Error (Hz)	Frequency Stability (ppm)	Frequency Stability (ppm)	Frequency Stability (ppm)	Verdict
BANDWIDTH	5MHz							
Temperature	Voltage	64QAM	16QAM	QPSK	64QAM	16QAM	QPSK	
Normal (25°C)	Normal	10.41	7.49	9.16	0.01244	0.00896	0.01095	PASS
Extreme (50°C)		11.61	5.57	6.90	0.01388	0.00665	0.00825	PASS



Extreme (40°C)		13.36	15.55	2.96	0.01597	0.01859	0.00353	PASS
Extreme (30°C)		7.13	12.02	16.13	0.00852	0.01436	0.01928	PASS
Extreme (20°C)		9.11	12.43	4.23	0.01089	0.01485	0.00505	PASS
Extreme (10°C)		12.62	13.08	3.75	0.01509	0.01563	0.00448	PASS
Extreme (0°C)		4.58	12.45	2.04	0.00548	0.01488	0.00243	PASS
Extreme (-10°C)		16.85	3.61	4.06	0.02014	0.00432	0.00486	PASS
Extreme (-20°C)		1.73	15.52	2.44	0.00207	0.01855	0.00291	PASS
Extreme (-30°C)		16.67	10.92	2.65	0.01993	0.01306	0.00317	PASS
25°C	LV	1.67	6.22	15.52	0.00199	0.00744	0.01856	PASS
	HV	11.47	15.03	14.83	0.01371	0.01797	0.01773	PASS
Condition		Freq.Error (Hz)	Freq.Error (Hz)	Freq.Error (Hz)	Frequency Stability (ppm)	Frequency Stability (ppm)	Frequency Stability (ppm)	Verdict
BANDWIDTH	10MHz							
Temperature	Voltage	64QAM	16QAM	QPSK	64QAM	16QAM	QPSK	
Normal (25°C)	Normal	11.09	15.89	14.12	0.01325	0.01899	0.01688	PASS
Extreme (50°C)		5.12	8.37	10.91	0.00612	0.01001	0.01304	PASS
Extreme (40°C)		4.22	6.07	14.33	0.00505	0.00725	0.01713	PASS
Extreme (30°C)		17.76	17.49	1.26	0.02123	0.02091	0.00151	PASS
Extreme (20°C)		8.55	17.33	10.59	0.01023	0.02072	0.01266	PASS
Extreme (10°C)		4.77	7.74	12.86	0.00570	0.00925	0.01538	PASS
Extreme (0°C)		15.46	1.18	1.89	0.01848	0.00141	0.00226	PASS
Extreme (-10°C)		17.13	13.22	4.29	0.02048	0.01580	0.00512	PASS
Extreme (-20°C)		13.67	4.06	10.08	0.01634	0.00485	0.01205	PASS
Extreme (-30°C)		5.90	2.70	16.24	0.00705	0.00322	0.01942	PASS
25°C	LV	7.66	4.93	13.80	0.00915	0.00589	0.01650	PASS
	HV	3.74	8.24	1.99	0.00447	0.00985	0.00237	PASS

6.6. Spurious Emissions at Antenna Terminals

Sweep the whole frequency band through the range from 9kHz to the 10th harmonic of the carrier, the emissions more than 20 dB below the limit are not reported.

The signal beyond the limit is carrier.

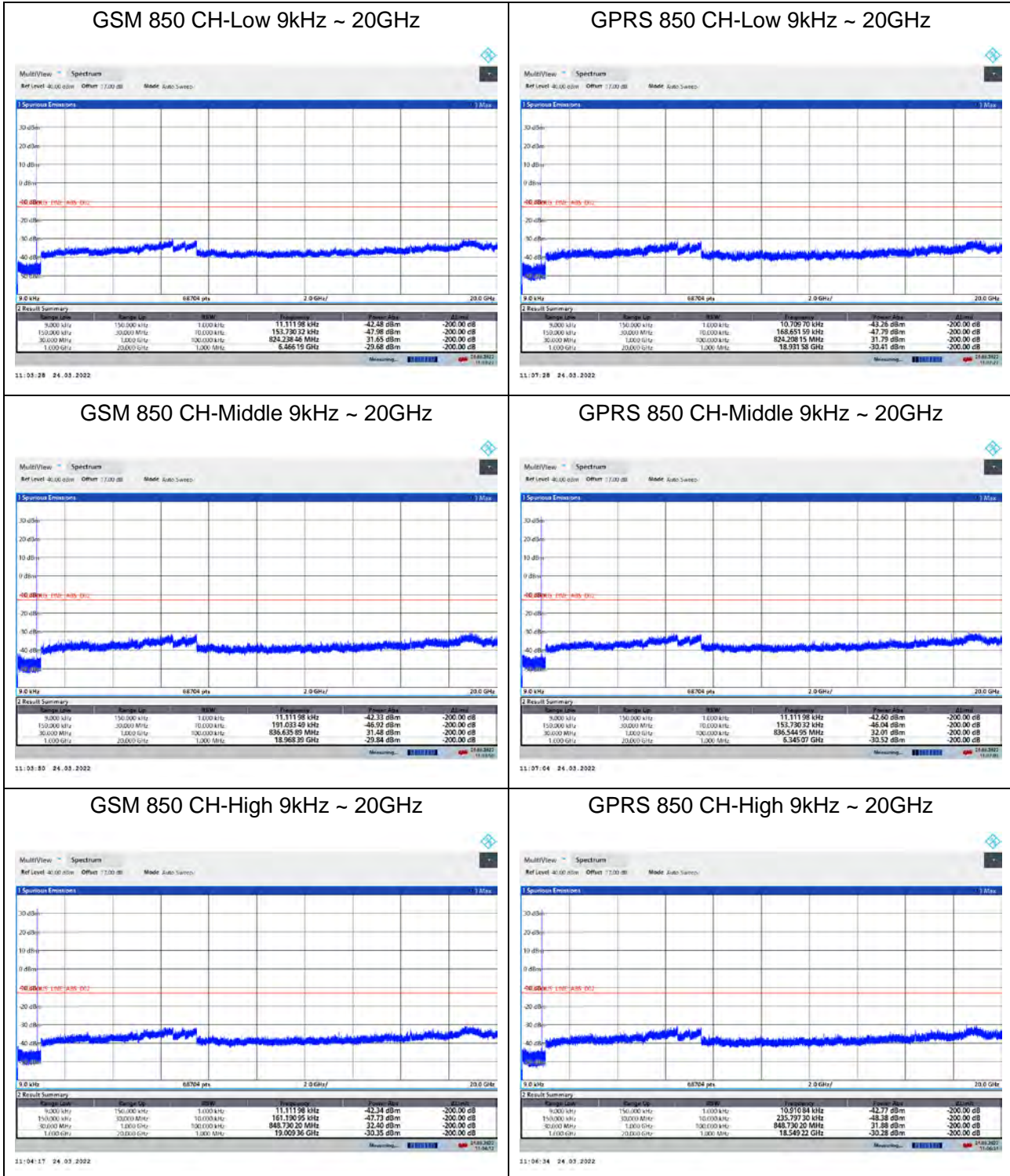



EGPRS 850 CH-Low 9kHz ~ 20GHz

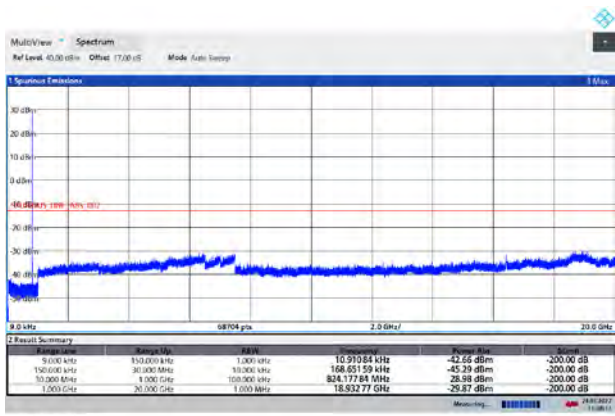

11:08:14 24.03.2022

WCDMA BAND V CH-Low 9kHz ~ 20GHz

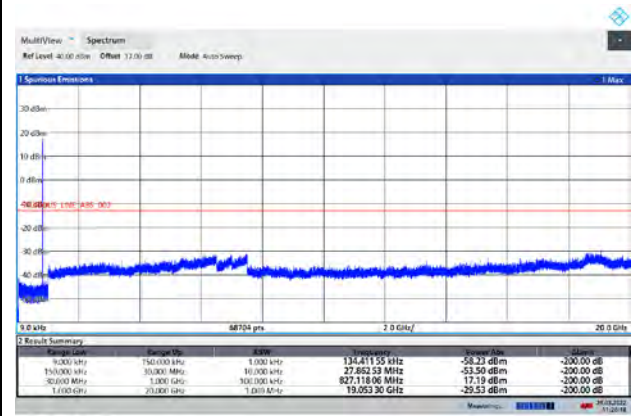

11:26:19 24.03.2022

EGPRS 850 CH-Middle 9kHz ~ 20GHz

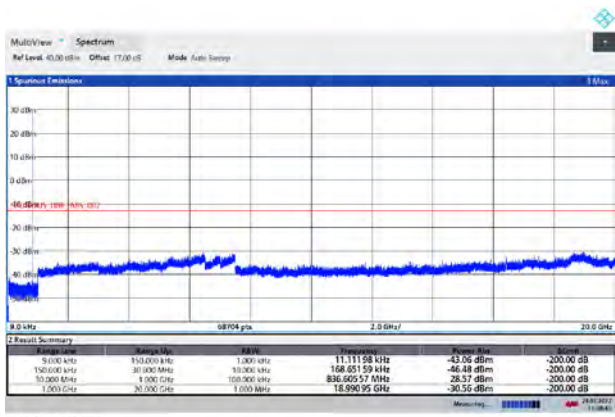

11:08:48 24.03.2022

WCDMA BAND V CH-Middle 9kHz ~ 20GHz

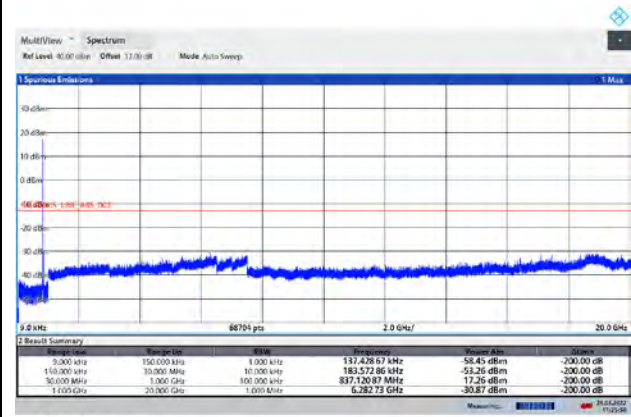

11:27:01 24.03.2022

EGPRS 850 CH-High 9kHz ~ 20GHz

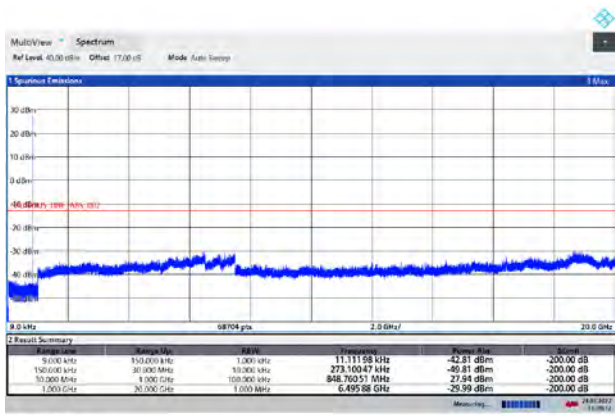

11:09:12 24.03.2022

WCDMA BAND V CH-High 9kHz ~ 20GHz

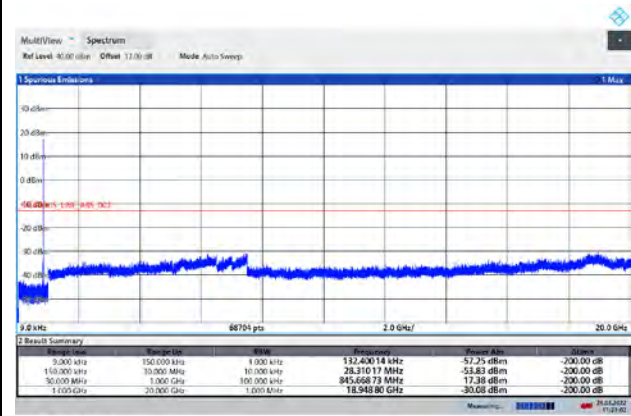

11:27:04 24.03.2022

LTE Band 5 1.4MHz CH-Low 9kHz~10GHz

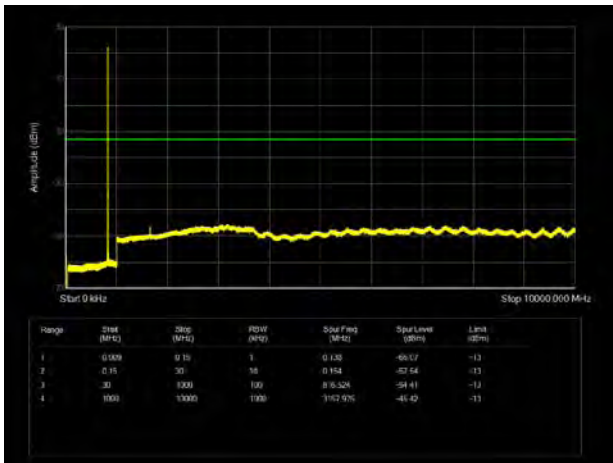

LTE Band 5 3MHz CH-Low 9kHz~10GHz

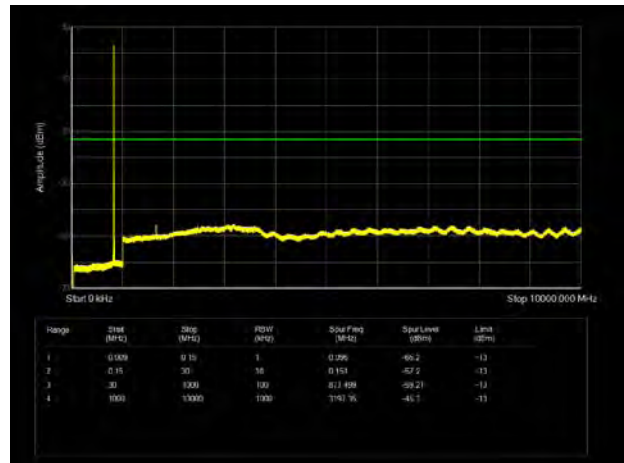

LTE Band 5 1.4MHz CH-Middle 9kHz~10GHz

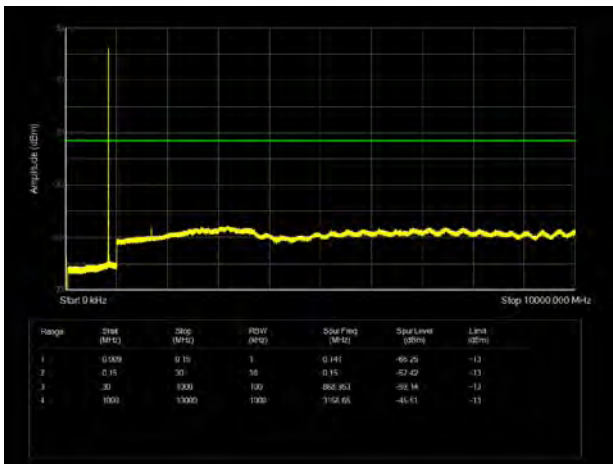

LTE Band 5 3MHz CH-Middle 9kHz~10GHz

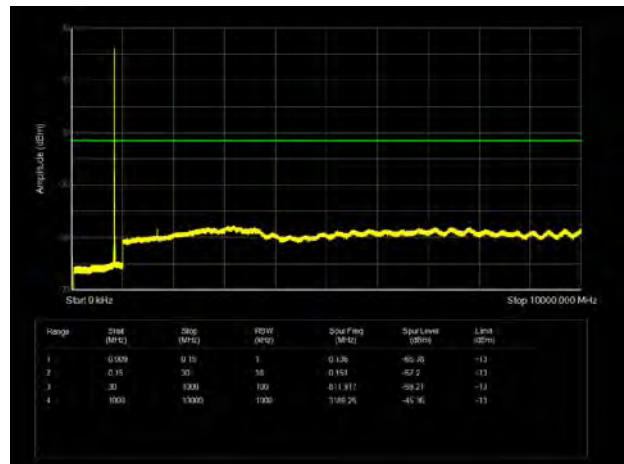

LTE Band 5 1.4MHz CH-High 9kHz~10GHz

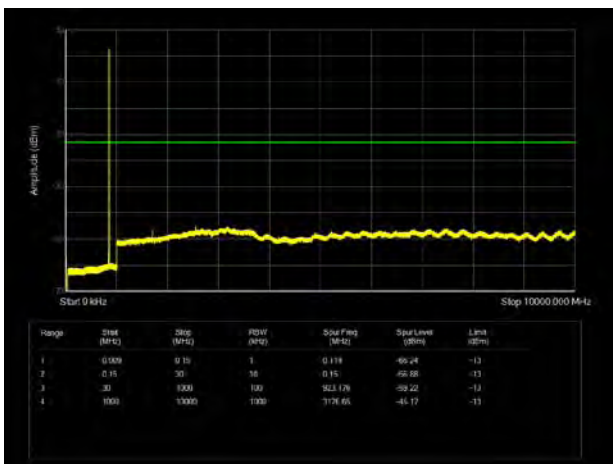

LTE Band 5 3MHz CH-High 9kHz~10GHz

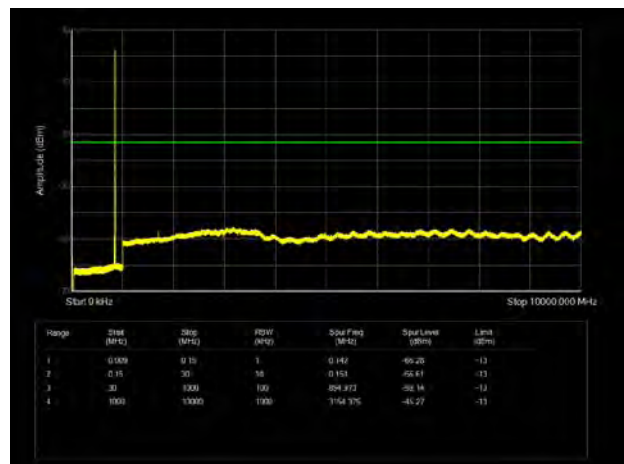

LTE Band 5 5MHz CH-Low 9kHz~10GHz

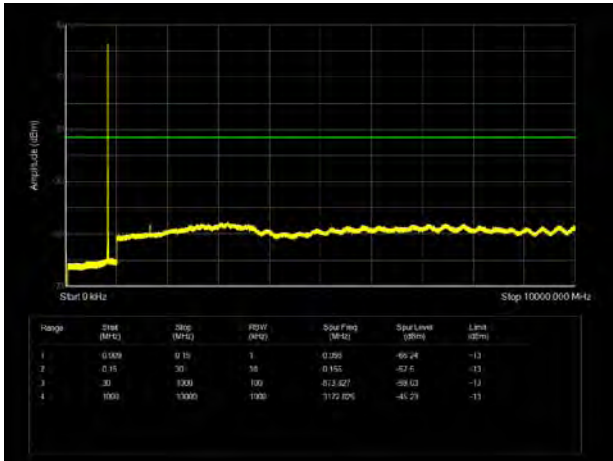

LTE Band 5 10MHz CH-Low 9kHz~10GHz

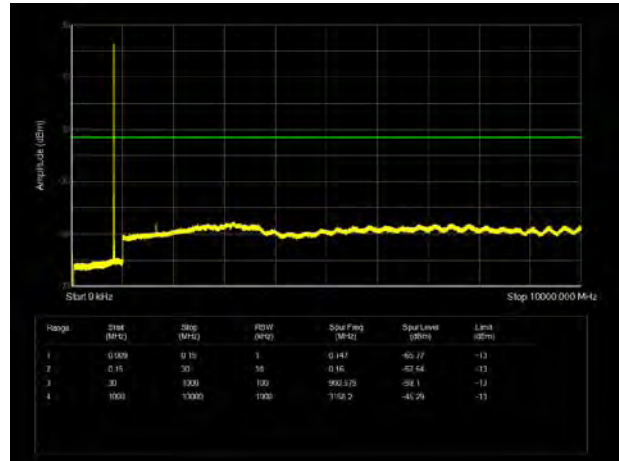

LTE Band 5 5MHz CH-Middle 9kHz~10GHz

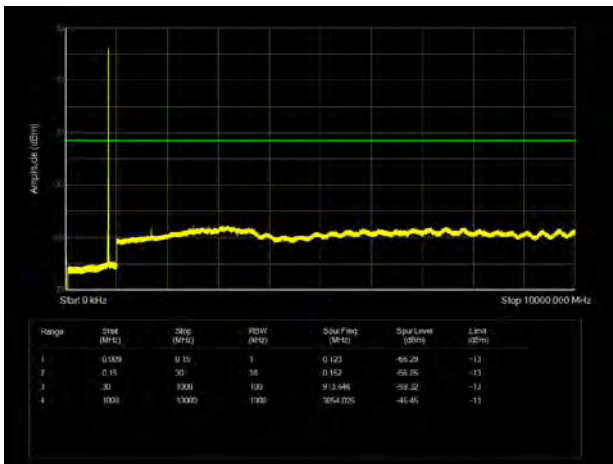

LTE Band 5 10MHz CH-Middle 9kHz~10GHz

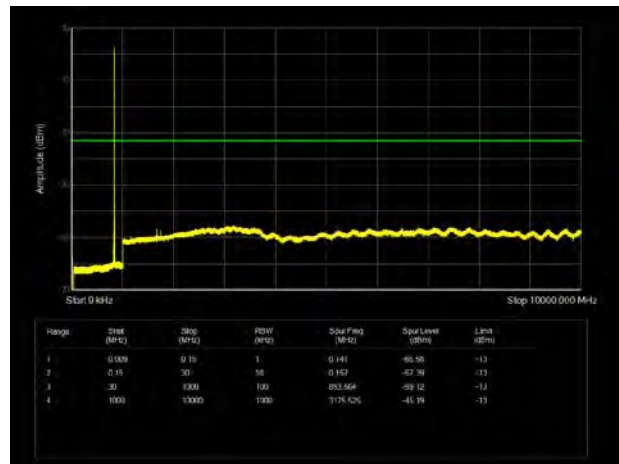

LTE Band 5 5MHz CH-High 9kHz~10GHz

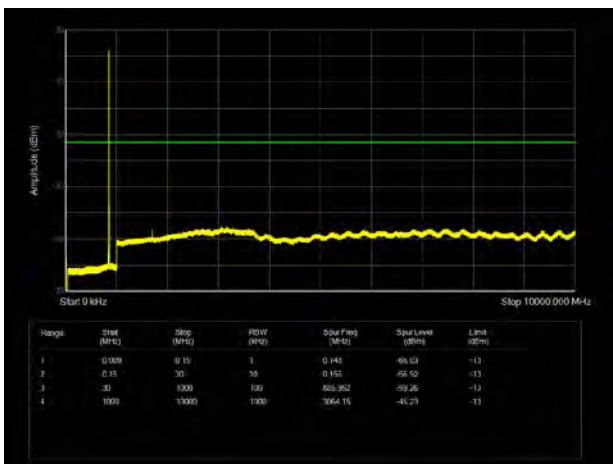

LTE Band 5 10MHz CH-High 9kHz~10GHz

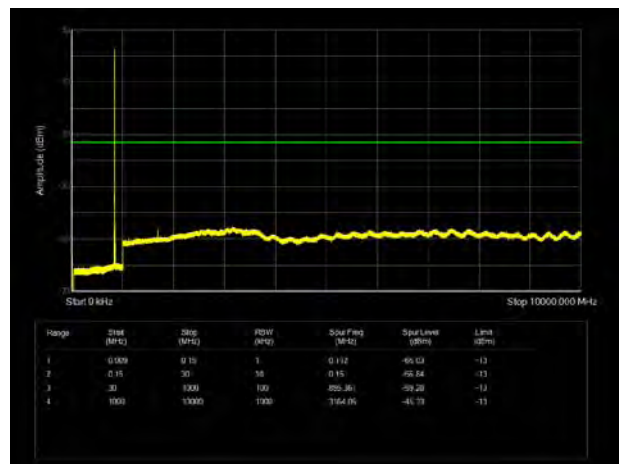



6.7. Radiates Spurious Emission

Sweep the whole frequency band through the range from 9kHz to the 10th harmonic of the carrier, the emissions below the noise floor will not be recorded in the report.

During the test, preliminary tests were performed all Antenna, and the Main Antenna was selected as the worst case. Worst-case test data is documented in this report.

GSM 850 CH-Middle

Harmonic	Frequency (MHz)	SG (dBm)	Cable Loss (dB)	Gain (dBi)	Antenna Polarization	ERP Level (dBm)	Limit (dBm)	Margin (dB)	Azimuth (deg)
2	1673.00	-66.45	1.70	8.70	Horizontal	-61.60	-13.00	48.60	270
3	2510.25	-55.77	2.30	12.00	Horizontal	-48.22	-13.00	35.22	45
4	3346.40	-65.41	2.70	12.70	Horizontal	-57.56	-13.00	44.56	0
5	4183.00	-62.99	3.00	12.50	Horizontal	-55.64	-13.00	42.64	135
6	5019.60	-58.83	3.40	12.50	Horizontal	-51.88	-13.00	38.88	180
7	5856.20	-59.68	3.40	12.80	Horizontal	-52.43	-13.00	39.43	45
8	6692.80	-59.59	4.10	11.50	Horizontal	-54.34	-13.00	41.34	225
9	7529.40	-55.46	4.20	12.20	Horizontal	-49.61	-13.00	36.61	45
10	8366.00	-56.83	4.30	12.50	Horizontal	-50.78	-13.00	37.78	0

Note: 1. The other Spurious RF Radiated emissions level is no more than noise floor.

2. The worst emission was found in the antenna is Horizontal position.

WCDMA Band V CH-Middle

Harmonic	Frequency (MHz)	SG (dBm)	Cable Loss (dB)	Gain (dBi)	Antenna Polarization	ERP Level (dBm)	Limit (dBm)	Margin (dB)	Azimuth (deg)
2	1673.20	-68.01	1.70	8.70	Horizontal	-63.16	-13.00	50.16	45
3	2509.80	-66.19	2.30	12.00	Horizontal	-58.64	-13.00	45.64	0
4	3346.40	-65.66	2.70	12.70	Horizontal	-57.81	-13.00	44.81	315
5	4183.00	-63.58	3.00	12.50	Horizontal	-56.23	-13.00	43.23	0
6	5019.60	-58.77	3.40	12.50	Horizontal	-51.82	-13.00	38.82	270
7	5856.20	-58.90	3.40	12.80	Horizontal	-51.65	-13.00	38.65	90
8	6692.80	-57.84	4.10	11.50	Horizontal	-52.59	-13.00	39.59	0
9	7529.40	-55.31	4.20	12.20	Horizontal	-49.46	-13.00	36.46	270
10	8366.00	-55.12	4.30	12.50	Horizontal	-49.07	-13.00	36.07	135

Note: 1. The other Spurious RF Radiated emissions level is no more than noise floor.

2. The worst emission was found in the antenna is Horizontal position.



LTE Band 5 1.4MHz CH-Middle

Harmonic	Frequency (MHz)	SG (dBm)	Cable Loss (dB)	Gain (dBi)	Antenna Polarization	ERP Level (dBm)	Limit (dBm)	Margin (dB)	Azimuth (deg)
2	1673.00	-67.68	1.70	8.70	Vertical	-62.83	-13.00	49.83	45
3	2509.50	-57.60	2.30	12.00	Vertical	-50.05	-13.00	37.05	0
4	3346.00	-64.65	2.70	12.70	Vertical	-56.80	-13.00	43.80	225
5	4182.50	-63.16	3.00	12.50	Vertical	-55.81	-13.00	42.81	0
6	5019.00	-59.61	3.40	12.50	Vertical	-52.66	-13.00	39.66	90
7	5855.50	-59.37	3.40	12.80	Vertical	-52.12	-13.00	39.12	180
8	6692.00	-58.96	4.10	11.50	Vertical	-53.71	-13.00	40.71	225
9	7528.50	-55.54	4.20	12.20	Vertical	-49.69	-13.00	36.69	315
10	8365.00	-56.10	4.30	12.50	Vertical	-50.05	-13.00	37.05	90

Note: 1. The other Spurious RF Radiated emissions level is no more than noise floor.
2. The worst emission was found in the antenna is Vertical position.

LTE Band 5 5MHz CH-Middle

Harmonic	Frequency (MHz)	SG (dBm)	Cable Loss (dB)	Gain (dBi)	Antenna Polarization	ERP Level (dBm)	Limit (dBm)	Margin (dB)	Azimuth (deg)
2	1668.60	-67.17	1.70	8.70	Vertical	-62.32	-13.00	49.32	270
3	2503.30	-57.15	2.30	12.00	Vertical	-49.60	-13.00	36.60	0
4	3466.20	-64.56	2.70	12.70	Vertical	-56.71	-13.00	43.71	315
5	4215.90	-62.62	3.00	12.50	Vertical	-55.27	-13.00	42.27	225
6	5165.60	-58.88	3.40	12.50	Vertical	-51.93	-13.00	38.93	0
7	5815.30	-59.06	3.40	12.80	Vertical	-51.81	-13.00	38.81	90
8	6765.00	-58.56	4.10	11.50	Vertical	-53.31	-13.00	40.31	180
9	7614.70	-55.79	4.20	12.20	Vertical	-49.94	-13.00	36.94	270
10	8464.40	-55.70	4.30	12.50	Vertical	-49.65	-13.00	36.65	0

Note: 1. The other Spurious RF Radiated emissions level is no more than noise floor.
2. The worst emission was found in the antenna is Vertical position.



LTE Band 5 10MHz CH-Middle

Harmonic	Frequency (MHz)	SG (dBm)	Cable Loss (dB)	Gain (dBi)	Antenna Polarization	ERP Level (dBm)	Limit (dBm)	Margin (dB)	Azimuth (deg)
2	1664.40	-65.32	1.70	8.70	Vertical	-60.47	-13.00	47.47	45
3	2496.60	-57.57	2.30	12.00	Vertical	-50.02	-13.00	37.02	0
4	3328.00	-65.91	2.70	12.70	Vertical	-58.06	-13.00	45.06	90
5	4160.00	-64.12	3.00	12.50	Vertical	-56.77	-13.00	43.77	90
6	4992.00	-60.34	3.40	12.50	Vertical	-53.39	-13.00	40.39	225
7	5824.00	-58.52	3.40	12.80	Vertical	-51.27	-13.00	38.27	180
8	6656.00	-58.65	4.10	11.50	Vertical	-53.40	-13.00	40.40	45
9	7488.00	-55.38	4.20	12.20	Vertical	-49.53	-13.00	36.53	90
10	8320.00	-55.68	4.30	12.50	Vertical	-49.63	-13.00	36.63	0

Note: 1. The other Spurious RF Radiated emissions level is no more than noise floor.
2. The worst emission was found in the antenna is Vertical position.

7. Main Test Instruments

Name	Manufacturer	Type	Serial Number	Calibration Date	Expiration Date
Wireless Communication Tester	Anritsu	MT8000A	6261844783	2021-05-15	2022-05-14
Wireless Communication Tester	Anritsu	MT8821C	6201538758	2021-05-15	2022-05-14
Climate Chamber	WEISS	VT 4002	58226119450 010	2021-05-15	2022-05-14
Base Station Simulator	R&S	CMW500	150415	2021-05-15	2022-05-14
Spectrum Analyzer	Keysight	N9020A	MY52330084	2021-05-15	2022-05-14
Universal Radio Communication Tester	Agilent	E5515C	GB44400275	2021-05-15	2022-05-14
Universal Radio Communication Tester	StarPoint	SP9500	SP9500-2044 0	2021-05-15	2022-05-14
Signal Analyzer	R&S	FSV3030	101411	2021-12-12	2022-12-11
Spectrum Analyzer	R&S	FSV30	104028	2021-05-15	2022-05-14
Loop Antenna	SCHWARZBECK	FMZB1519	1519-047	2020-04-02	2023-04-01
TRILOG Broadband Antenna	Schwarzbeck	VULB 9163	01111	2019-09-12	2022-09-11
Horn Antenna	Schwarzbeck	BBHA 9120D	1594	2020-12-17	2023-12-16
Software	R&S	EMC32	10.35.10	/	/

*****END OF REPORT *****



ANNEX A: The EUT Appearance

The EUT Appearance is submitted separately.



ANNEX B: Test Setup Photos

The Test Setup Photos is submitted separately.