

Wireless Thermo Recorder User's Manual

RTR-501/RTR-502/RTR-503/RTR-502Pt

T&D Corporation

<http://www.tandd.com>

Shimadachi 817-1, Matsumoto, Nagano JAPAN 390-0852
Tel: +81-263-40-0131 Fax: +81-263-40-3152

© Copyright T&D Corporation. All rights reserved.
This is printed using recycled paper.

2009.07 16004590010 (1st Edition)

1. Part Names

RTR-501 RTR-502 / 503 / 502Pt

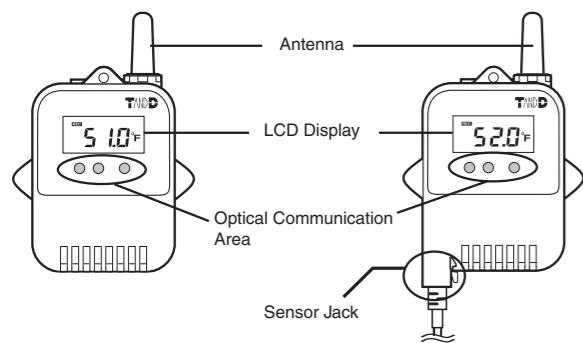

LCD Display

When being used in very cold or hot environments the display may become difficult to read. This is not a malfunction.

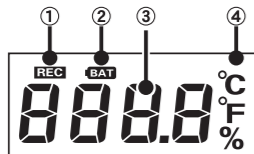

- Recording Status (REC)**
ON: Displayed during recording or when FULL of data.
BLINKING :Waiting for programmed start.
Not ON: Recording has been stopped.
- Battery Life Warning (BAT)**
Displayed when time to change the battery.
- Measurement and Message Display Area**
Current measurements or operational messages will appear here.
- Unit of Measurement**

(For details about the message area, see the back of this manual)

What is a Wireless Thermo Recorder?

These products are data loggers designed to measure and record temperature and humidity with built-in wireless communication capability. No longer it is necessary to manually gather the data loggers. Rather via our special short-range wireless communication function, data download, settings, analysis and the saving of data can all be done via a wireless Base Unit connected to your PC.

RTR-501	RTR-502	RTR-503	RTR-502Pt
With Internal Temperature Sensor	With External Temperature Sensor TR-5106 Included	With External Temperature / Humidity Sensor TR-3310 Included	With Sensor Adaptor RTR-05P1 Included (Sensor not Included)

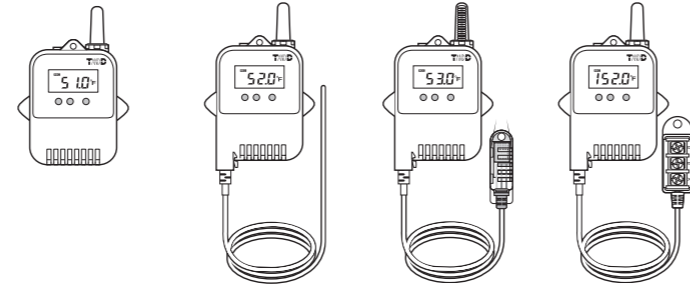

Common Items Included

Lithium Battery (LS14250) x 1, Tube x 1, Strap x 1
User's Manual (Warranty) x 1

We have prepared an array of Remote Units to meet your needs: RTR-501/502/503/502Pt. These Remote Units cannot be used without a Base Unit. Base Units must be purchased separately.

2. Connecting a Sensor

Make sure that the sensor or sensor adaptor is inserted until you hear a "click" sound.

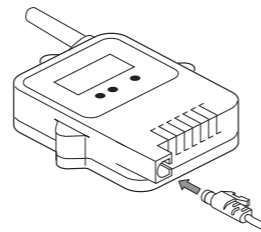

About Sensors for RTR-502Pt

Pt100 and Pt1000 sensors are not included in the package with the RTR-502Pt. Please purchase separately.

- Loosen the screws on the terminal block of the sensor adaptor.
- Connect the sensor terminals to the terminal block as instructed in the diagram on the terminal block.
- Securely tighten the screws on the terminal block.

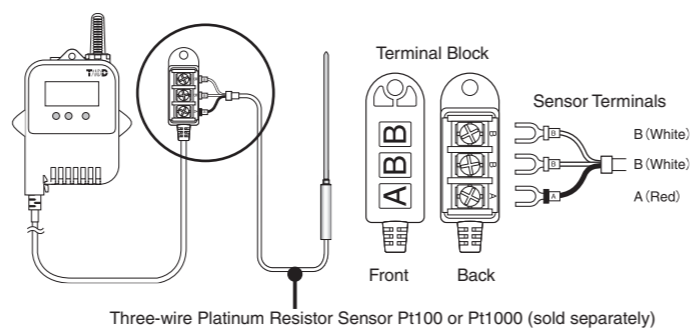

Three-wire Platinum Resistor Sensor Pt100 or Pt1000 (sold separately)

3. Installing the Battery

When a battery is installed, temperature measurement will start at the factory default settings or the previously set ones.

Factory Default Settings

Recording Mode: Endless

Recording Interval: 10 minutes

Recording Start: Immediate Start

- Remove the screws and open the case.
- Insert the battery into the tube and install as shown in the diagram.
- Check the rubber packing for any cuts or scratches and replace the cover as it was when opened.

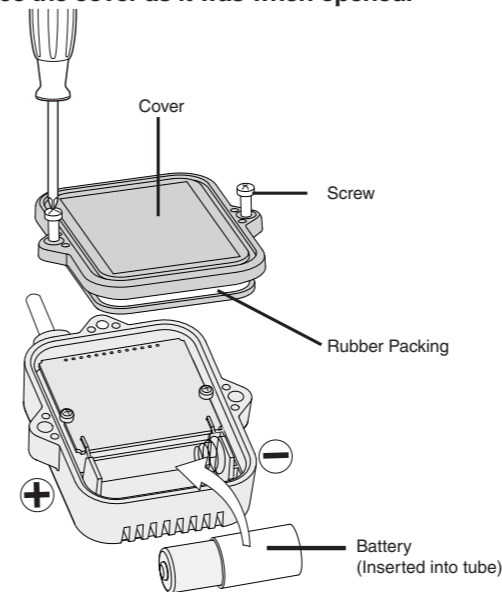

- Make sure to use the proper size and type of screwdriver. A Phillips #1 head screwdriver is best.
- If using a CR2 lithium battery the tube is not necessary.
- If dirt or scratches are present on the rubber packing, water resistance will be reduced.
- Be sure to completely close the cover. Make sure not to over tighten the screws.
Appropriate torque: 20N*cm ~ 30N*cm [2Kg*cm ~ 3Kg*cm]

Notes about Battery Installation

- If a new battery has been installed and recording does not immediately start, nothing appears in the display or any other such malfunction, please remove the battery, check to make sure plus and minus are correct and re-insert the battery.
- After inserting the battery for the first time, nothing may appear or occur for about 10 seconds; this is not a malfunction.
- If + (plus) and - (minus) are mistaken, or if the battery terminals + and - are shorted, the recorded data that is stored in the logger will be lost.
- Make sure no water or foreign objects get inside the case.
- To maintain water resistibility when changing batteries we suggest also changing the rubber packing and the drying agent.

About Lithium Batteries

- Lithium batteries (CR2) sold in stores may also be used, but if you are using in an environment below -20 °C, above 60 °C, or in a situation such as transportation where continued vibration is likely to occur, we strongly suggest the purchase and use of the our lithium battery LS14250. (Please purchase optional part 11P2)
- When using an LS14250 type lithium battery, even though a new battery has been inserted the BAT indicator may remain on for a short time. This is due to a special characteristic of the battery. Note that the longer the battery has been in storage the longer the amount of time, from 10 minutes to about 1 hour, the BAT indicator will remain on. If during that time the Base Unit is used to get the Current Status of the Remote Unit, the remaining battery level will show that the battery level is low.
- Please store the Lithium Battery LS14250 in a place that is 20 °C or less.

4. Battery Replacement Mark

When the replacement mark [BAT] appears, try to replace the battery with a new one as soon as possible.



- When it is time for the battery to be replaced, the [BAT] mark will appear.

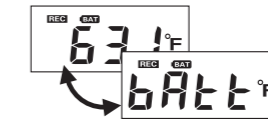

- If you do not change the battery and continue using the unit, the temperature display will intermittently display [bAtt].

- After this point the downloading of data can no longer be done via wireless communication.
- Without changing the battery and attempting to use optical communication to download data, the communication may be broken and if so all recorded data may be lost.
- If the battery is changed at this point, recording will continue after it has been changed.

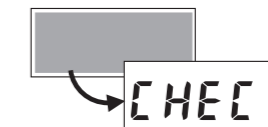

- If the battery is further left unchanged, the display will automatically shut off. If, at this time, the battery is changed, [CHEC] will appear in the display after which recording will begin again using the previously set recording conditions.

* All of the recorded data up until that point will be erased.

The estimated battery life is one year if the wireless communication interval is 10minutes or longer. If the wireless communication interval is less than 10 minutes or if the recording interval is set at 10 seconds or less battery life will be shortened.

5. Communicating with a PC

To register a data logger as a Remote Unit connect the data logger to the computer. For details about how to connect the unit, see the Introductory Guide that comes with the Base Unit or see the application's Help.

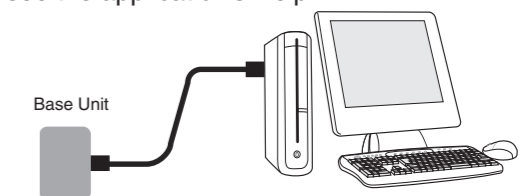

- Communication errors may occur in environments where temperatures are very high or very low.
- If the battery level of the data logger is very low, communication may be broken or may not be possible.

6. Message Area

[Memory FULL]



If recording under the ONE-TIME MODE, when the number of data readings reaches the specified capacity, recording will stop and [FULL] will be displayed intermittently with the current temperature.

Data Capacity (Estimate of time until FULL is displayed)

Recording Interval	1 second	30 second	15 minutes	60 minutes
RTR-501/502/502Pt	about 4 hours and 26 minutes	about 5 days and 13 hours	about 166 days and 16 hours	about 1 year and 10 months
RTR-503	about 2 hours and 13 minutes	about 2 days and 18 hours	about 83 days and 8 hours	about 11 months

RTR-501 / RTR-502 / RTR-502Pt (16,000 data readings x 1ch.)

EX: Recording Interval of 30 seconds x Data readings of 16,000 = 480,000 seconds (about 5 days and 13 hours)

RTR-503 (8,000 data readings x 2 ch)

EX: Recording Interval of 30 seconds x Data readings of 8000 = 240,000 seconds (about 2 days and 18 hours)

[Check]



If this appears, all data that was stored in the Logger will have been erased. This will be displayed under the following conditions:

- The first time a battery was inserted after purchase
- If the battery is replaced after having been taken out for a long period

[Wireless Communication]



This will appear when data is being sent via wireless communication to the Base Unit.

[Measurement Range Exceeded] (for RTR-502 and RTR-502Pt)

RTR-502 (Celsius)

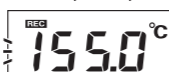

RTR-502

The temperature display blinks when the temperature goes below -60 °C or above 155 °C (-76 °F or +311 °F).

RTR-502Pt (Fahrenheit)



RTR-502Pt

The temperature display blinks when the temperature goes below -199.9 °C or above 600 °C (-327.8 °F or +1112 °F).

*When measuring and recording using Fahrenheit, although it is possible to measure between -327.8 and 1112 degrees, the LCD on the Logger can only show between -199.9 and 999.9 degrees.

*Even when the LCD reading is blinking, the RTR-502Pt's internal measuring and recording circuitry will continue to measure and record to the limits of its operating range. While blinking the reading shown in the display should be interpreted as only a rough guideline for the actual temperature being measured and recorded. If measuring becomes impossible, the display will read [----] and will continue to blink.

[No Sensor]



Displayed when a sensor has not been connected or the wire has been broken. Measurement and recording will continue and battery power consumed.

Products Specification

Unit type	RTR-501	RTR-502	RTR-503		RTR-502Pt
Measurement Channel	1 Temperature Channel	1 Temperature Channel	1 Temperature Channel	1 Humidity Channel	1 Temperature Channel
Sensor	Internal Temp. Sensor	External Temp. Sensor (TR-5106)	External Temp. and Humidity Sensor (TR-3310)		External Temp. Sensor Three - Wire Pt100 / Pt1000 (Sold Separately)
Thermal-Constant Time	15 minutes L Type: 25 minutes	Approx. 15 Sec. (in air) Approx. 2 Sec. (in agitated water)	-		-
Sensor Response Time	-	-	About 7 min. (90% response)		-
Measurement Range	- 40 to 80 °C	- 60 to 155 °C	0 to 55 °C	10 to 95%RH	-199.9 to 600 °C (*1)
Measurement Accuracy	Avg. +/- 0.5 °C	Avg. +/- 0.3 °C (-20 to 80 °C) Avg. +/- 0.5 °C (-40 to -20 °C / 80 to 110 °C) Avg. +/- 1.0 °C (-60 to -40 °C / 110 to 155 °C)	Avg. +/- 0.3 °C	Avg. +/-5%RH (at 25 °C and 50%RH)	+/- 0.3 °C (-199.9 to 80 °C) +/- 0.5 °C (80 to 450 °C) +/- 1.0 °C (450 to 600 °C) *at 0 to 50 °C / Sensor accuracy is not included.
Measurement Display Resolution	0.1 °C	0.1 °C	0.1 °C	1%RH	0.1 °C
Recording Interval	1,2,5,10,15,20,30 seconds / 1,2,5,10,15,20,30,60 minutes Total of 15 choices				
Recording Capacity	16,000 Readings x 1 Channel	16,000 Readings x 1 Channel	8,000 Readings x 2 Channels		16,000 Readings x 1 Channel
Recording Mode	Endless (Overwrite oldest data when capacity is full) / One-time (Stop recording when capacity is full)				
LCD Display Items	Current Readings, Recording Settings, Battery Life Warning, Over Measurement Range Warning, Amount of Recorded Data				
Power	Lithium Battery (LS14250(SAFT)) x 1 Lithium Battery (LS26500) x 1 / AC Adaptor (sold separately) (*2)				
Battery Life	Approx. 1 year				
Wireless Specifications	FCC Part15 Section247 / IC RSS-210 [Frequency Range: 902 to 928MHz]				
Transmission Range	Approx. 500ft (May vary with conditions)				
Interface	Wireless Communication / Optical Communication				
Communication Speed	Collection of a full unit of data: Wireless communication = about 2 minutes / Optical communication = about 160 seconds				
Water Resistance	IP67 (immersion proof)	IP64 (rated for use in daily life) (*4)			
Dimensions	H62mm x W 47mm x D19mm (excluding protrusions / antenna length 23mm)				
Weight	Approx. 56g. (including 1 lithium battery)				
Unit Temp. Resistance	Resistance -30 to 80 °C (Unit temp resistance and measurement range is -40 to 80 °C but wireless communication cannot occur in an environment of less than -30 °C)				
Others	In order to download data via wireless communication, it is necessary to purchase Base Unit.				

(*1) When measuring and recording using Fahrenheit, although it is possible to measure between -327.8 and 1112 degrees, the LCD on the Logger can only show between -199.9 and 999.9 degrees.

(*2) Contact your local authorized TandD sales representative.

(*3) Battery life depends on measurement environment, recording interval and battery performance.

(*4) Water protection is rated as splashproof (IP64) when the sensor is connected. Not for continued immersion.

TR-5106

Teflon-Shielded Sensor for RTR-502

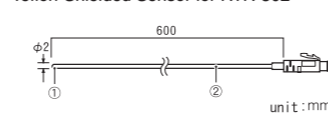

Cable Length: 0.6m
Thermal Time Constant: Approx. 15 Sec. (in air)
Approx. 2 Sec. (in agitated water)
Possible Temperature Measurement Range: -60 to 155°C Sensor
Temperature Resistance: -70 to 180°C
Temp Measurement Accuracy: Average +/-0.3°C (-20 to 80°C)
Average +/-0.5°C (-40 to -20°C / 80 to 110°C)
Average +/-1.0°C (-60 to -40°C / 110 to 155°C)
Materials: ① Thermistor ② Teflon Resin (FEP) - Shielded

TR-3310

Temp / Humidity Sensor for RTR-503

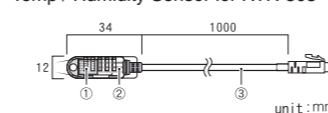

Cable Length: 1.0m
Possible Temperature Measurement Range: 0 to 55°C
Possible Humidity Measurement Range: 10 to 95%RH
Sensor Temperature Resistance: -10 to 60°C
Temp Measurement Accuracy: Average +/- 0.3°C
Humidity Measurement Accuracy: +/-5%RH (At 25°C / 50%RH)
Service Life: 1 year (under normal operational conditions)
Operational Conditions: Without dew condensation, water leakage or effect from corrosive gas or organic solvents.
Materials: ① Temperature / Humidity Sensor ② Polypropylene Resin ③ Vinyl Coated Electrical Wire

RTR-05P1

Sensor Adaptor Cable for RTR-502Pt

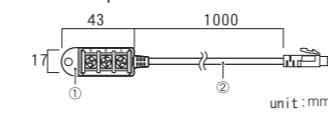

Cable Length: 1.0m
Sensor Temperature Resistance: -25 to 60°C
Materials: ① Vinyl ② Vinyl Coated Wire
Optional Sensors for the RTR-52Pt can be selected from the Optional Sensors for TR-81. Moreover, designed for easy compatibility, the RTR-52Pt can be used with any three-wire type Pt100 / Pt1000 temperature sensor.

Notices about this User's Manual

In order to properly use this product, please carefully read this manual before using. T&D Corporation accepts no responsibility for any malfunction of and / or trouble with this product or with your computer that is caused by the improper handling of this product and will deem such trouble or malfunction as falling outside the conditions for free repair outlined in the attached warranty.

- All rights of this User's Manual belong to T&D Corporation. It is prohibited to use, duplicate and / or arrange a part or whole of this User's Manual without the permission of T&D Corporation.
- "TANDD", "T&D" and the logo of T&D Corporation are all registered property of T&D Corporation.
- Specifications, design and other contents outlined in this manual are subject to change without notice.
- We are not responsible for any malfunction or trouble caused by the use of our product or by any problem caused by the use of measurement results of our unit. Please be fully aware of this before using our product.
- On screen messages in this manual may vary slightly from the actual messages.
- Please notify the shop where you purchased this product or T&D Corporation of any mistakes, errors or unclear explanations in this manual.
- T&D Corporation accepts no responsibility for any damage or loss of income caused by the use of our product.
- This product has been designed for private or industrial use only. It is not for use in situations where strict safety precautions are necessary such as in connection with medical equipment, whether directly or indirectly.
- Some of our products, which come under the category of strategic goods in foreign trade law, need the permission of the Japanese government to be exported outside of Japan.
- This User's Manual cannot be reissued, so please keep it in a safe place.
- Please carefully read this User's Manual and Warranty.

Safety Precautions and Instructions * Please carefully observe the following safety measures when using our product.

To prevent any loss or damage to our customers, other people and/or property, and to ensure the proper use of our products we ask that before using our product you carefully read, understand and follow the safety rules and precautions for our products as outlined below.

⚠ DANGER

- ⚡ Do not take apart, repair or modify the main unit. It may cause fire, electrocution or damage. Ask the shop where you purchased the products or T&D Corporation to carry out any repairs.
- 🔥 If any smoke or strange smells are emitted from the unit, immediately cease using it. Continued use may cause fire, electrocution or damage.
- ⚡ Do not use any batteries other than those that are recommended. It may cause fire or damage.
- ⚠ If water or a foreign object enters the case, immediately cease using it.

⚠ CAUTION

- ⚠ We are not responsible for any malfunction or trouble caused by the use of our product or by any problem caused by the malfunction of our unit. Please be fully aware of this before using our product.
- ⚠ This product has been designed for private or industrial use only. It is not for use in situations where strict safety precautions are necessary such as in connection with medical equipment whether directly or indirectly.
- ⚠ Do not drop or expose the unit to strong impact.
- ⚠ Do not put your fingers or foreign matter into the sensor connection.
- ⚠ Battery terminals may provide insufficient contact due to age or vibration. Please be careful not to lose data due to insufficient contact.
- ⚠ Battery life depends on the measurement environment, communication frequency, recording interval and battery quality.
- ⚠ Avoid using the lithium batteries, LS 14250 for long periods at temperatures over 60 °C. The battery life may be significantly decreased.
- ⚠ Operate the units with the latest version of RTR-500GSM for Windows. The latest version software can be downloaded from our home page.

⚠ Notes about Sensors

TR-5106, the standard Sensor for RTR-502.

- Do not fold the sensor (tip section) or expose it to a strong impact. This may cause trouble or break the wire.
- The sensor and the cable are shielded by Teflon. If the shield has a defect or tear, the waterproof capacity is lost as the shield is very thin. Inspect it before operation.
- Insert the sensor tip of least 5cm or more to obtain an accurate temperature measurement.
- Only use the sensor within the sensor heat-durability range.

TR-3310, the standard temperature and humidity sensor for RTR-503.

- Use the sensor only within the measurable temperature and humidity range (Temperature: 0 °C to 55 °C and , Humidity: 10% to 95% RH)
- The Temperature/Humidity sensor cable cannot be extended.
- When the sensor is not used, put it in the attached plastic bag with a drying agent and keep it in cool, dark place at 5 °C to 25 °C and 30% RH or less.
- The replacement period for the standard sensor is 1 year. Replace it when 1 year has passed after opening the bag.

RTR-05P1, the sensor adaptor for RTR-502Pt.

- This sensor adaptor is not waterproof. Only use in an environment where there is no condensation or possibility of wetness.
- When connecting the sensor, please follow the connection diagram on the terminal block. Please make sure to securely tighten the screws to the terminal block so as there is no chance of becoming unfastened.

⚠ Wireless Regulations

Radio, EMC and Safety Regulations



This device complies with part 15 of the Federal Communications Commission (FCC) rules and with RSS-210 of the Industry Canada (IC). Operation is subject to the following conditions:
(1) This device may not cause harmful interference, and
(2) This device must accept any interference received, including interference that may cause undesired operation.

Changes or Modifications not expressly approved by the manufacturer for compliance could void the user's authority to operate the equipment.

Note: This equipment has been tested and found to comply with the limits for a Class B Digital Device, pursuant to Part 15 of the FCC Rules. These limits are designed to provide reasonable protection against harmful interference in a residential installation. This equipment generates, uses and can radiate radio frequency energy and, if not installed and used in accordance with the instructions, may cause harmful interference to radio communications.

- However, there is no guarantee that interference will not occur in a particular installation. If this equipment does cause harmful interference to radio or television reception, which can be determined by turning the equipment off and on, the user is encouraged to try to correct the interference by one or more of the following measures:
 - Reorient or relocate the receiving antenna.
 - Increase the separation between the equipment and receiver.
 - Connect the equipment into an outlet on a circuit different from that to which the receiver is connected.
 - sssConsult the dealer or an experienced radio/TV technician for help.

Wireless Thermo Recorders Warranty

RTR-501 / RTR-502 / RTR-503 / RTR-502Pt

Customer's name:	
Address:	
Phone No.:	
Dealer's name:	
Address:	
Phone No.:	
Guarantee period:	12 months from date of purchase
Date of purchase:	

Statement of Limited Warranty

- This product is warranted to be free from defects in materials and workmanship for a period of one (1) year following the date of purchase. Should the product fail to operate per specification in normal use during this period T&D will repair the unit or provide a replacement free of charge. T&D will not accept returns for any reason other than defects during the warranty period, and will not accept any product that has been misused, dropped, abused or inappropriately used or mistreated at any time.
- This warranty is strictly limited to repair or replacement-in-kind for defective product. T&D makes no other warranty, either express or implied, and will not accept liability beyond the remedies stated herein. Specifically, T&D will not accept liability for direct, indirect, special, consequential or incidental damages arising from the use of this product.
- Customers wishing to submit a defective product for repair or replacement during the warranty period should first contact the dealer from whom it was originally purchased. After receiving a return authorization the defective product should then be packaged along with a description of the difficulties being experienced, proof of purchase and all included accessories and materials, and returned it to the dealer. In the event of difficulty contacting the original dealer, customers should contact the nearest authorized T&D sales representative. A list of these can be found on the company's website, www.tandd.com, or it can be obtained by contacting TandD US directly.
- This limited warranty statement gives the customer specific legal rights. The customer may also have other rights which vary from state to state in the United States, from province to province in Canada, and from country to country elsewhere in the world. To the extent this limited warranty statement is inconsistent with local law, this statement shall be deemed modified to be consistent with such local law.
- For further information relating to product repair or replacement, or for other service questions after the termination of the warranty period, customers should contact their local authorized T&D sales representative.

T&D CORPORATION