

# TEST REPORT

For

**Mobile Base Station**

In conformity with

**FCC CFR 47 Part15 (October 1, 2007) / RSS-210 Issue 7, RSS-Gen Issue 2**

**Model: RTR-500GSM**

**FCC ID/ IC Certification No.: SRD10010 / 5558A-10010**

**Test Item: Mobile Base Station**

**Report No: RY0906Z22R1**

**Issue Date: 22 June, 2009**

**Prepared for**

T&D CORPORATION  
817-1 Shimadachi, Matsumoto, Nagano, Japan 390-0852

**Prepared by**

RF Technologies Ltd.  
472, Nippa-cho, Kohoku-ku, Yokohama, 223-0057, Japan  
Telephone: +81+(0)45- 534-0645  
FAX: +81+(0)45- 534-0646

**This report shall not be reproduced, except in full, without the written permission of RF Technologies Ltd. The test results in this report apply only to the sample tested. RF Technologies Ltd. is managed to ISO17025 and has the necessary knowledge and test facilities for testing according to the referenced standards.**

## Table of contents

<b>1</b>	<b>General information.....</b>	<b>3</b>
1.1	Product description .....	3
1.2	Test(s) performed/ Summary of test result .....	3
1.3	Test facility .....	4
1.4	Measurement uncertainty.....	4
1.5	Summary of test results.....	5
1.5.1	Table of test summary.....	5
1.6	Setup of equipment under test (EUT) .....	5
1.6.1	Test configuration of EUT .....	5
1.6.2	Operating condition: .....	5
1.6.3	Setup diagram of tested system:.....	6
1.7	Equipment modifications .....	6
1.8	Deviation from the standard .....	6
<b>2</b>	<b>Test procedure and test data .....</b>	<b>7</b>
2.1	Occupied Bandwidth (6dB / 99%) .....	7
2.2	Peak Output Power .....	9
2.3	Power Spectral Density.....	11
2.4	Conducted Spurious Emissions (Antenna Port).....	13
2.5	Transmitter Radiated spurious emissions .....	14
2.5.1	Below 30 MHz.....	16
2.5.2	Between 30 – 1000 MHz .....	17
2.5.3	Above 1000 MHz.....	18
2.6	Transmitter AC power line conducted emissions .....	20
2.7	Receiver Radiated spurious emissions .....	23
2.7.1	Between 30 – 1000 MHz .....	23
2.7.2	Above 1000 MHz.....	24
2.8	Receiver AC power line conducted emissions .....	25
2.9	Maximum Permissible Exposure (Exposure of Humans to RF Fields) .....	27
<b>3</b>	<b>Test setup photographs .....</b>	<b>28</b>
3.1	Definition of the EUT axis.....	28
3.2	Antenna Port Measurements .....	29
3.3	Radiated spurious emissions.....	30
3.4	AC power line conducted emissions.....	31
<b>4</b>	<b>List of utilized test equipment/ calibration .....</b>	<b>32</b>

## History

Report No.	Date	Revisions	Revised By
RY0906Z22R1	22 June, 2009	Initial Issue	K. Ohnishi

## 1 General information

### 1.1 Product description

Test item : Mobile Base Station  
Manufacturer : T&D CORPORATION  
Address : 817-1 Shimadachi, Matsumoto, Nagano, Japan 390-0852  
Model : RTR-500GSM  
FCC ID : SRD10010  
IC Certification No : 5558A-10010  
Serial numbers : 3E9E0001  
Fundamental Operated Frequency : Tx/Rx Freq. (902 - 928 MHz)  
Oscillator frequencies : 32.768 kHz, 9.83 MHz, 13.1072 MHz, 48 MHz  
Type of Modulation : FSK  
Number of channels : 22ch (Manufacturer declared)  
RF Output Power : 7.18dBm (measured at the antenna terminal)  
Antenna Gain : 0 dBi (Manufacturer declared)  
Antenna Type : Dipole antenna  
Receipt date of EUT : 19 June, 2009  
Nominal power source voltages : AC 120V, 60Hz (Battery: DC 6.0V)

### 1.2 Test(s) performed/ Summary of test result

Test specification(s) : FCC CFR 47. Part 15 (October 1, 2007) / RSS-210 Issue 7, RSS-Gen Issue 2  
Test method(s) : ANSI C63.4: 2003  
Test(s) started : 20 June, 2009  
Test(s) completed : 21 June, 2009  
Purpose of test(s) : Grant for Certification of FCC / IC  
Summary of test result : Complied

Note: The above judgment is only based on the measurement data and it does not include the measurement uncertainty. Accordingly, the statement below is applied to the test result.

The EUT complies with the limit required in the standard in case that the margin is not less than the measurement uncertainty in the Laboratory.

Compliance of the EUT is more probable than non-compliance is case that the margin is less than the measurement uncertainty in the Laboratory.

Test engineer :   
K. Ohnishi  
EMC testing Department

Reviewer :   
T. Ikegami  
Manager  
EMC testing Department

### 1.3 Test facility

The Federal Communications Commission has reviewed the technical characteristics of the test facilities at RF Technologies Ltd., located in 472, Nippa-cho, Kohoku-ku, Yokohama, 223-0057, Japan, and has found these test facilities to be in compliance with the requirements of 47 CFR Part 15, section 2.948, per October 1, 2007. The description of the test facilities has been filed under registration number 319924 at the Office of the Federal Communications Commission. The facility has been added to the list of laboratories performing these test services for the public on a fee basis.

The list of all public test facilities is available on the Internet at <http://www.fcc.gov>.

Registered by Voluntary Control Council for Interference by Information Technology Equipment (VCCI)

Each registered facility number is as follows;

Test site (Semi-Anechoic chamber 3m) R-2393

Test site (Shielded room) C-2617

Registered by Industry Canada (IC): The registered facility number is as follows;

Test site No. 1 (Semi-Anechoic chamber 3m): 6974A

Accredited by **National Voluntary Laboratory Accreditation Program (NVLAP)** for the emission tests stated in the scope of the certificate under Certificate Number 200780-0

This report must not be used by the client to claim product certification, approval, or endorsement by NVLAP, NIST, or any agency of the Federal Government.



NVLAP LAB CODE 200780-0

### 1.4 Measurement uncertainty

The treatment of uncertainty is based on the general matters on the definition of uncertainty in “Guide to the expression of uncertainty in measurement (GUM)” published by ISO. The Lab’s uncertainty is determined by referring UKAS Publication LAB34: 2002 “The Expression of Uncertainty in EMC Testing” and CISPR16-4-2: 2003 “Uncertainty in EMC Measurements”.

The uncertainty of the measurement result in the level of confidence of approximately 95% (k=2) is as follows;

Conducted emission:  $\pm 1.9$  dB (10 kHz – 30 MHz)

Radiated emission (9 kHz - 30MHz):  $\pm 2.8$  dB

Radiated emission (30MHz - 1000MHz):  $\pm 5.7$  dB

Radiated emission (above 1000MHz):  $\pm 5.8$  dB

## 1.5 Summary of test results

### 1.5.1 Table of test summary

Requirement of;	Section in FCC15	Section in RSS210/ RSS-Gen	Result	Section in this report
1.5.1 Occupied Bandwidth (6dB/99%)	15.247(a)(2)	A8.2(a)	Complied	2.1
1.5.2 Peak Output Power	15.247(b)(3)	A8.4(4)	Complied	2.2
1.5.3 Power spectral density	15.247(e)	A8.2(b)	Complied	2.3
1.5.4 Conducted Spurious Emissions	15.247(d)	A8.5	Complied	2.4
1.5.5 Transmitter Radiated Spurious Emissions	15.205(b)/15.209	2.6	Complied	2.5
1.5.6 Transmitter AC Power Line Conducted Emissions	15.207	RSS-Gen 7.2.2	Complied	2.6
1.5.7 Receiver Radiated Spurious Emissions	15.109	RSS-Gen 6	Complied	2.7
1.5.8 Receiver AC Power Line Conducted Emissions	15.107	RSS-Gen 7.2.2	Complied	2.8
1.5.9 Maximum Permissible Exposure (Exposure of Humans to RF Fields)	2.1091 1.1307(b)(1)	RSS-Gen 5.5/ RSS-102	Complied	2.9

## 1.6 Setup of equipment under test (EUT)

### 1.6.1 Test configuration of EUT

#### Equipment(s) under test:

	Item	Manufacturer	Model No.	Serial No.	Remarks
A	Mobile Base Station	T&D CORPORATION	RTR-500GSM	3E9E0001	
B	Alkaline Battery	TOSHIBA	-	-	SIZE: AA (4pcs)

#### Support Equipment(s):

	Item	Manufacturer	Model No.	Serial No.
C	AC Adapter	T&D CORPORATION	AD-0605	-

#### Connected cable(s):

No.	Item	Identification (Manu.e.t.c)	Shielded YES / NO	Ferrite Core YES / NO	Connector Type Shielded YES / NO	Length (m)
1	DC power cable	T&D CORPORATION	No	No	No	1.85

### 1.6.2 Operating condition:

#### Operating mode:

The EUT was tested under the following test mode prepared by the applicant:

- (1-1) FSK modulation, Continuous transmission (902.9376MHz)
- (1-2) FSK modulation, Continuous transmission (914.4576MHz)
- (1-3) FSK modulation, Continuous transmission (927.1296MHz)
- (2-1) Continuous receiving (902.9376MHz)
- (2-2) Continuous receiving (914.4576MHz)
- (2-3) Continuous receiving (927.1296MHz)

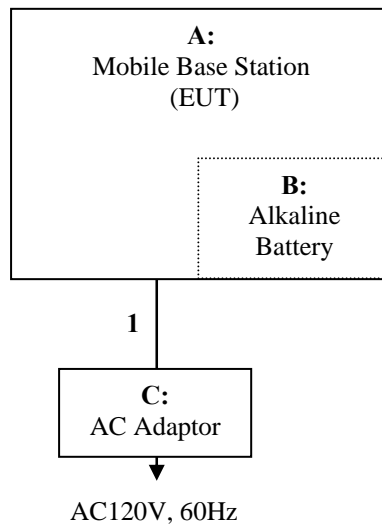
**1.6.3 Setup diagram of tested system:****1.7 Equipment modifications**

No modifications have been made to the equipment in order to achieve compliance with the applicable standards described in clause 1.2.

**1.8 Deviation from the standard**

No deviations from the standards described in clause 1.2.

## 2 Test procedure and test data

### 2.1 Occupied Bandwidth (6dB / 99%)

#### Test setup

Test setup is the following drawing. The antenna port of EUT was connected to the spectrum analyzer.

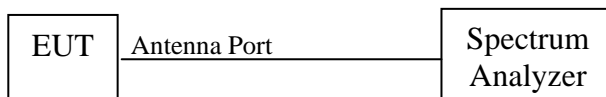

#### Test procedure

Measurement procedures were implemented according to the method of ANSI C63.4: 2003 clauses 13.1.7. The EUT antenna port connected to the spectrum analyzer. The RBW is set to 100 kHz. The VBW is set to 3 times of the RBW. The sweep time is coupled appropriate.

#### Limitation

Systems using digital modulation techniques may operate in the 902–928 MHz, 2400–2483.5 MHz, and 5725–5850 MHz bands. The minimum 6 dB bandwidth shall be at least 500 kHz.

#### Test equipment used (refer to List of utilized test equipment)

TR06	CL21				
------	------	--	--	--	--

#### Test results

Transmission Channel	Transmission Frequency	Bandwidth [kHz]	
		6dB	99%
Low (0ch)	902.9376	567.308	474.359
Middle (10ch)	914.4576	567.308	471.154
High (21ch)	927.1296	567.308	474.359

## Test Data

Tested Date: 21 June, 2009

Temperature: 21 °C  
 Humidity: 55 %  
 Atmos. Press: 1009 hPa

### Lch (902.9376MHz)

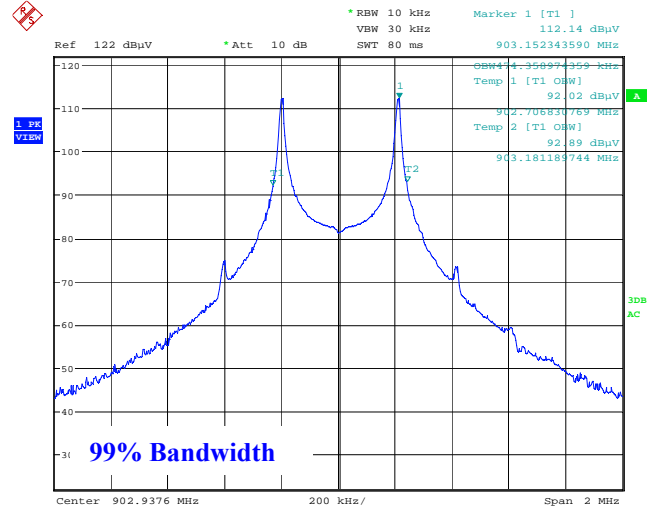
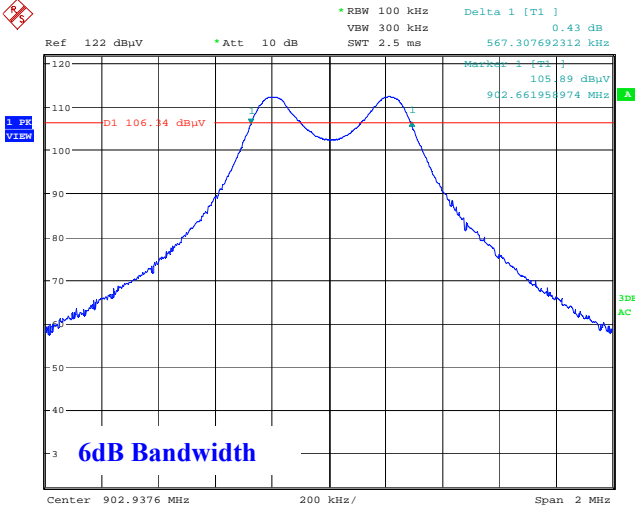

### Mch (914.4576MHz)

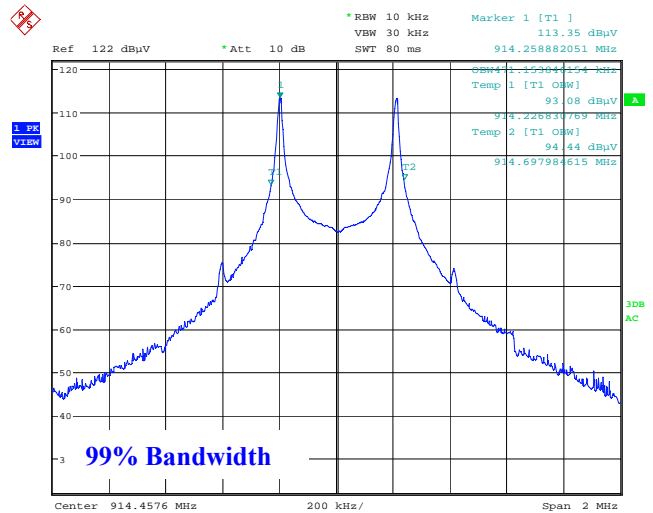
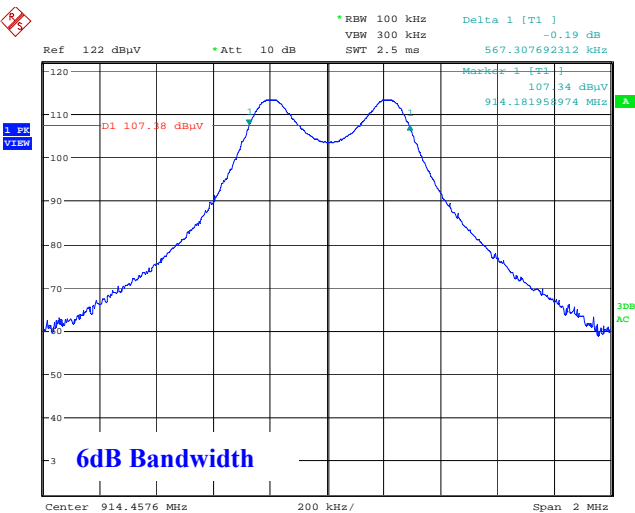

### Hch (927.1296MHz)

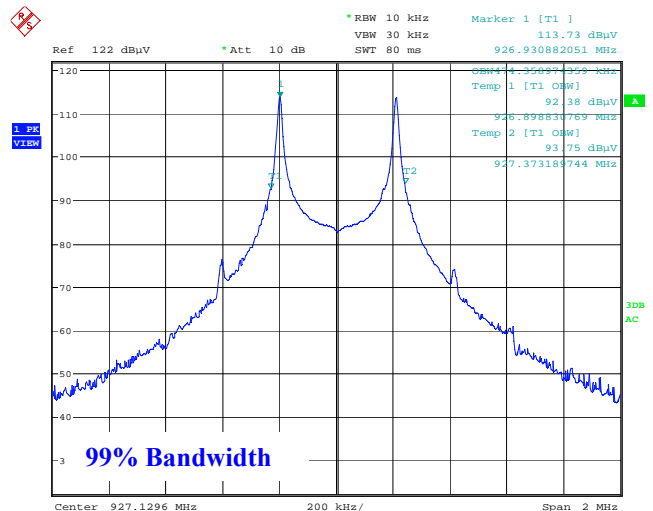
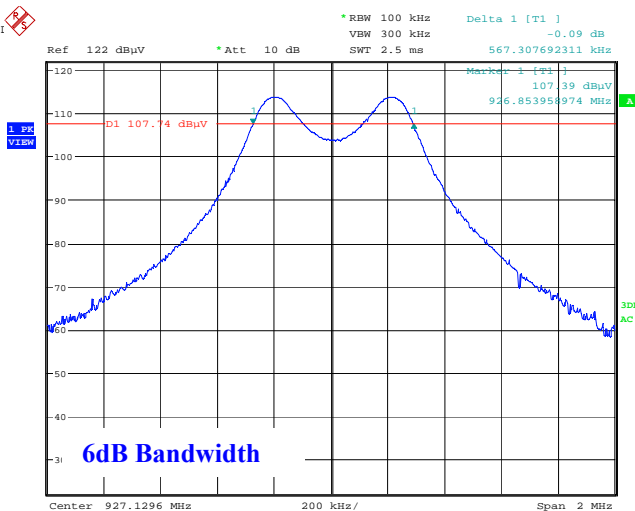



## 2.2 Peak Output Power

### Test setup

Test setup is the following drawing. The antenna port of EUT was connected to the spectrum analyzer.

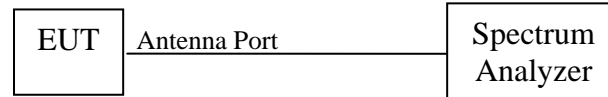

### Test procedure

The EUT antenna port connected to the spectrum analyzer. The RBW is set to the greater than 6dB bandwidth. The VBW is set to three times of RBW. The sweep time is coupled appropriate. The span is set to cover the carrier output spectrum. The analyzer is set to MAX HOLD.

### Limitation

For systems using digital modulation in the 902–928 MHz, 2400–2483.5MHz, and 5725–5850 MHz bands: 1 Watt.

### Test equipment used (refer to List of utilized test equipment)

TR06	CL21				
------	------	--	--	--	--

### Test results – comply with the limitation.

Transmission Channel (Frequency: MHz)	Cable loss (dB)	Output power (dBm) [Reading]	Output power (dBm) [Result]	Output power (mW) [Result]
Low (902.9376)	0.1	5.61	5.71	3.72
Middle (914.4576)	0.1	6.73	6.83	4.82
<b>High (927.1296)</b>	<b>0.1</b>	<b>7.08</b>	<b>7.18</b>	<b>5.22</b>

## Test Data

Tested Date: 21 June, 2009

Temperature: 21 °C  
Humidity: 55 %  
Atmos. Press: 1009 hPa

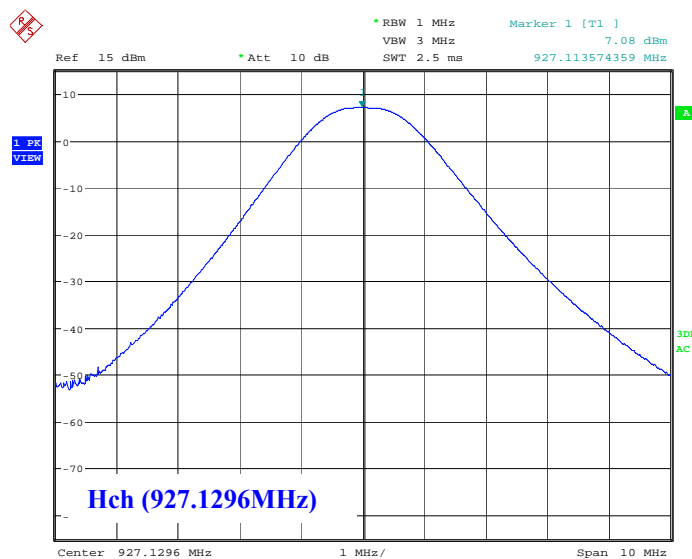
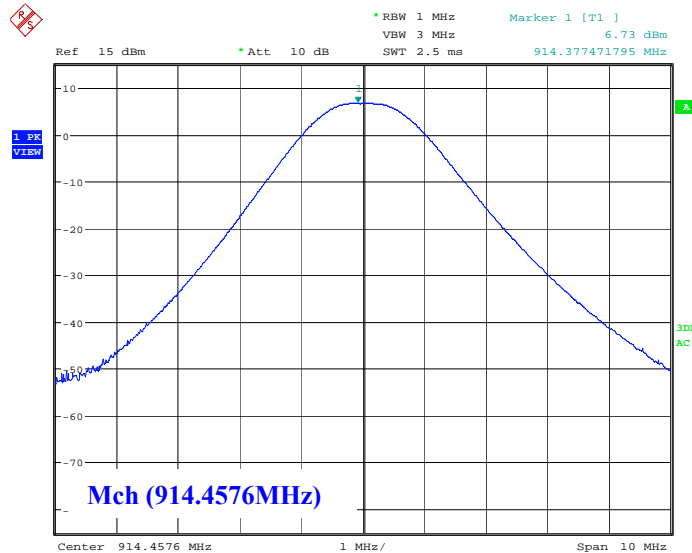
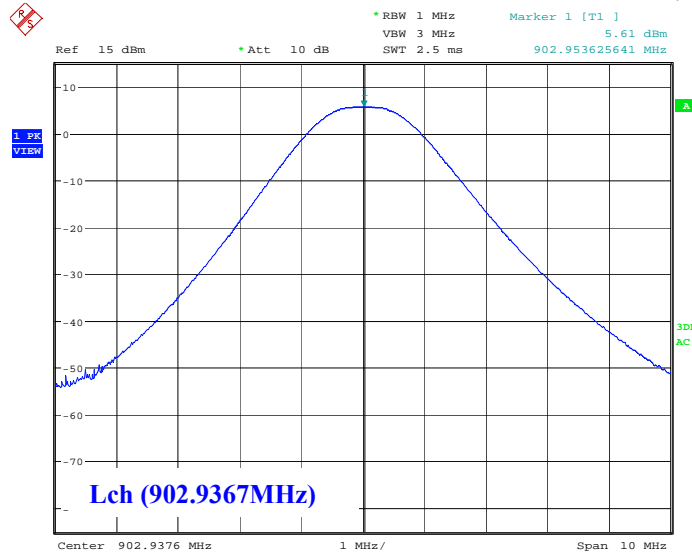

## 2.3 Power Spectral Density

### Test setup

Test setup is the following drawing. The antenna port of EUT was connected to the spectrum analyzer.

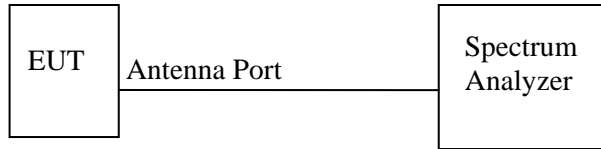

### Test procedure

The EUT antenna port connected to the spectrum analyzer. The RBW is set to 3 kHz. The VBW is set to 10 kHz. The sweep time is set to (SPAN / 3 kHz) seconds. The span is set to cover the carrier output spectrum. The correction factor is set to the spectrum analyzer in order to correct of the connected cable loss.

### Limitation

For digitally modulated systems, the power spectral density conducted from the intentional radiator to the antenna shall not be greater than 8 dBm in any 3 kHz band during any time interval of continuous transmission.

### Test equipment used (refer to List of utilized test equipment)

TR06	CL21				
------	------	--	--	--	--

### Test results – comply with the limitation.

Transmission Channel (MHz)	Power Spectral Density (dBm)
Low (902.9376)	5.48
Middle (914.4576)	6.54
<b>High (927.1296)</b>	<b>6.88</b>

## Test Data

Tested Date: 21 June, 2009

Temperature: 21 °C  
 Humidity: 55 %  
 Atmos. Press: 1009 hPa

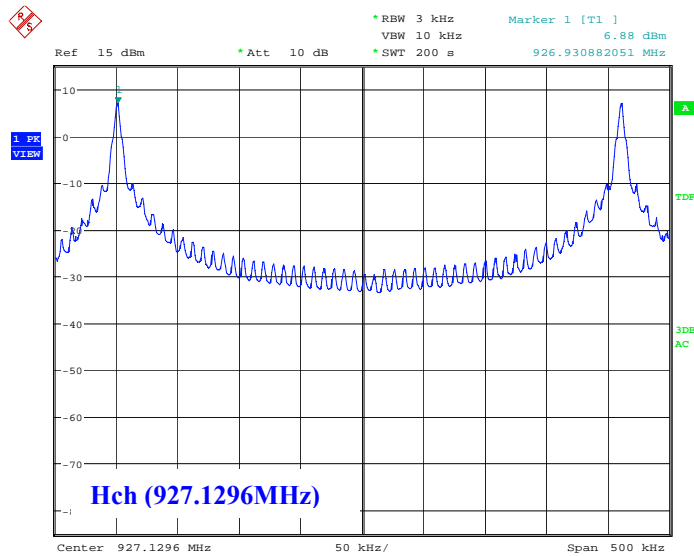
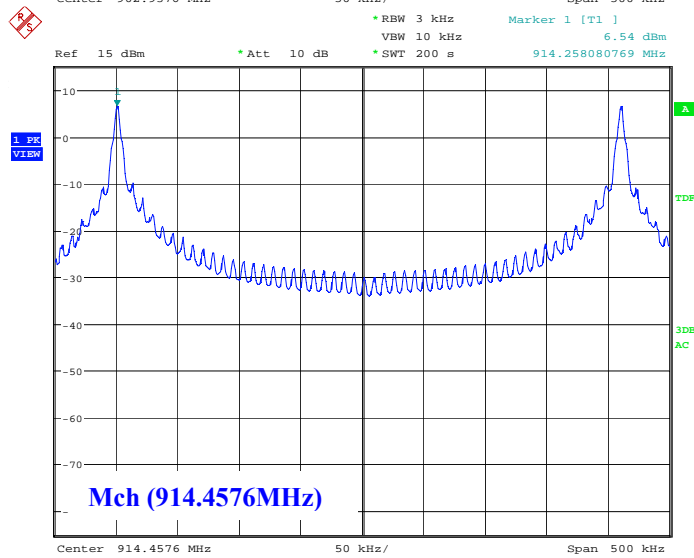
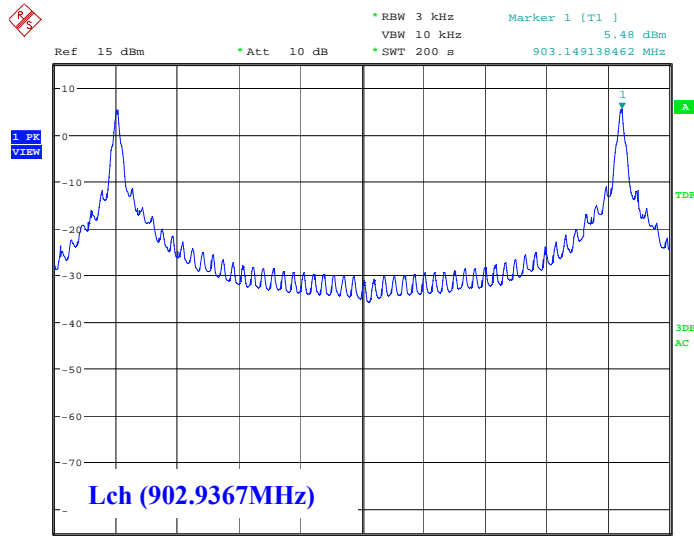

## 2.4 Conducted Spurious Emissions (Antenna Port)

### Test setup

Test setup is the following drawing. The antenna port of EUT was connected to the spectrum analyzer.

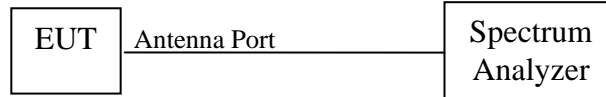

### Test procedure

The EUT antenna port connected to the spectrum analyzer. The RBW is set to 100 kHz. The VBW is set to 300 kHz. The sweep time is set to the coupled. The spectrum is cheated from 30 MHz to 10 GHz.

### Limitation

In any 100 kHz bandwidth outside the frequency band in which the spread spectrum or digitally modulated intentional radiator is operating, the radio frequency power that is produced by the intentional radiator shall be at least 20 dB below that in the 100 kHz bandwidth within the band that contains the highest level of the desired power, based on either an RF conducted or a radiated measurement, provided the transmitter demonstrates compliance with the peak conducted power limits.

### Test equipment used (refer to List of utilized test equipment)

TR06	CL23				
------	------	--	--	--	--

### Test results – comply with the limitation.

There were no conducted spurious emissions with levels of more than 20 dB below the applicable limit.

### Test Data

Tested Date: 21 June, 2009

Temperature: 21 °C  
 Humidity: 55 %  
 Atmos. Press: 1009 hPa

### Worst Configuration (Mch: 914.4576MHz)

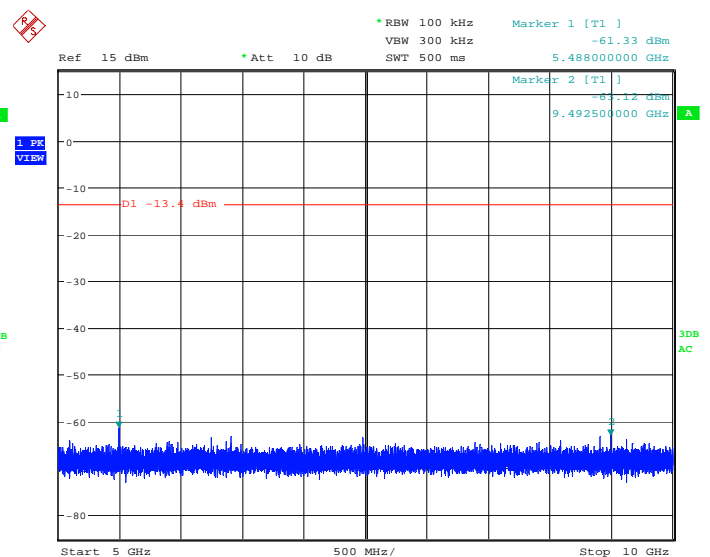
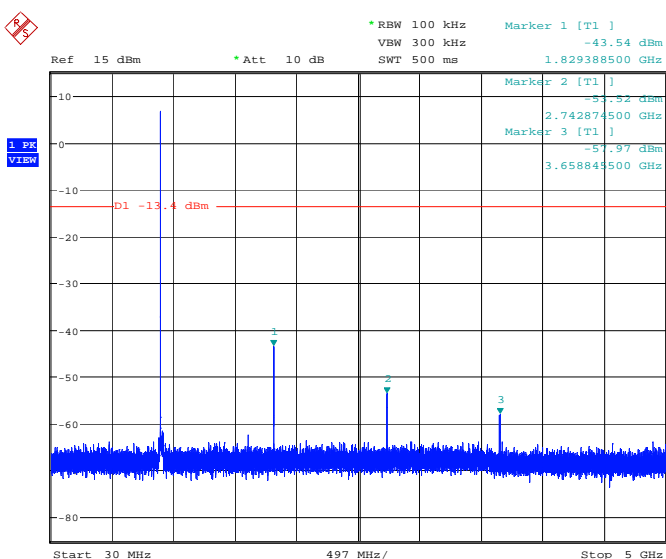

## 2.5 Transmitter Radiated spurious emissions

### Test setup

Test setup was implemented according to the method of ANSI C63.4: 2003 clause 6 “General requirements for EUT equipment arrangements and operation”, clause 8.2 and Annex H.3 “Radiated emission measurements setup”.

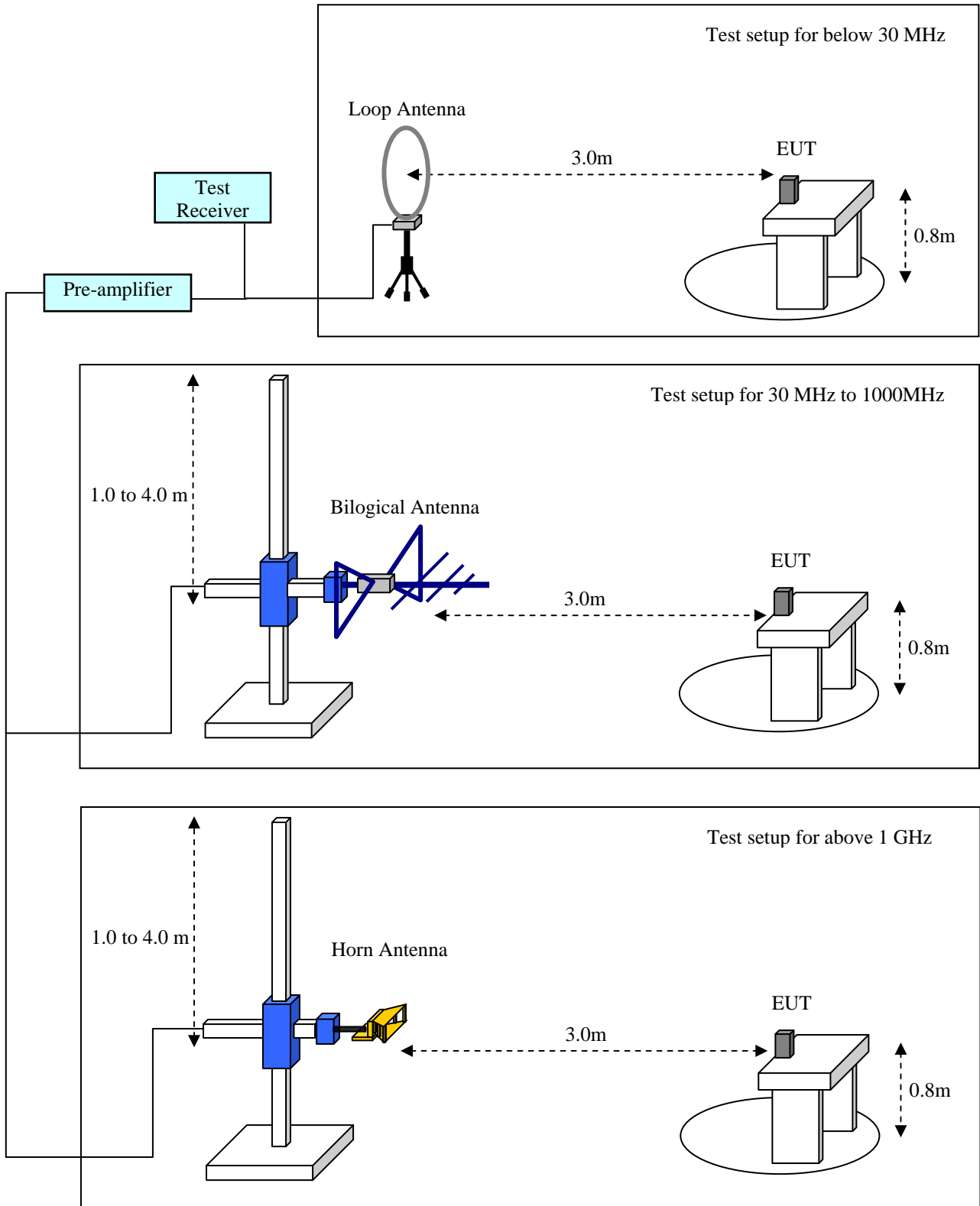

## Test procedure

Measurement procedures were implemented according to the method of ANSI C63.4: 2003 clauses 8.2. The EUT is placed on a non-conducted table which is 0.8m height from a ground plane and the measurement antenna to EUT distance is 3 meters. The turn table is rotated for 360 degrees to determine the maximum emission level. In the frequency range of 9 kHz to 30 MHz, a calibrated loop antenna was positioned with its plane vertical at the distance 3m from the EUT with an extrapolation of corrected distance factor and rotated about its vertical axis for maximum response at each azimuth about the EUT. For certain applications, the loop antenna also needs to be positioned horizontally. The center of the loop shall be 1 m above the ground.

In the frequency above 30 MHz, the antenna height scanned between 1m and 4m, and the antenna rotated to repeat the measurements for both the horizontal and vertical antenna polarizations.

During this measurement, receive antenna is adjusted the direction to keep the EUT within the beamwidth of receive antenna.

EUT is placed at three different orientations (X, Y and Z axis) in order to find the worst orientation.

The spectrum analyzer and receiver are set to the followings;

- Below 30 MHz: RBW=10 kHz, VBW= 30 kHz  
Final measurement is carried out with a receiver RBW of 9 kHz (QP)
- Between 30 - 1000 MHz: RBW=100 kHz, VBW= 300 kHz  
Final measurement is carried out with a receiver RBW of 120 kHz (QP)
- Above 1000 MHz: Peak measurement- RBW=1 MHz, VBW= 1 MHz  
Average measurement – RBW=1 MHz, VBW=10 Hz

## Applicable rule and limitation

§15.205 restricted bands of operation

Except as shown in paragraph 15.205 (d) of this section, only spurious emissions are permitted in any of the frequency bands listed below:

MHz	MHz	MHz	GHz
0.090 - 0.110	16.42 - 16.423	399.9 - 410	4.5 - 5.15
0.490 - 0.510	16.69475 - 16.69525	608 - 614	5.35 - 5.46
2.1735 - 2.1905	16.80425 - 16.80475	960 - 1240	7.25 - 7.75
4.125 - 4.128	25.5 - 25.67	1300 - 1427	8.025 - 8.5
4.17725 - 4.17775	37.5 - 38.25	1435 - 1626.5	9.0 - 9.2
4.20725 - 4.20775	73 - 74.6	1645.5 - 1646.5	9.3 - 9.5
6.215 - 6.218	74.8 - 75.2	1660 - 1710	10.6 - 12.7
6.26775 - 6.26825	108 - 121.94	1718.8 - 1722.2	13.25 - 13.4
6.31175 - 6.31225	123 - 138	2200 - 2300	14.47 - 14.5
8.291 - 8.294	149.9 - 150.05	2310 - 2390	15.35 - 16.2
8.362 - 8.366	156.52475 - 156.52525	2483.5 - 2500	17.7 - 21.4
8.37625 - 8.38675	156.7 - 156.9	2690 - 2900	22.01 - 23.12
8.41425 - 8.41475	162.0125 - 167.17	3260 - 3267	23.6 - 24.0
12.29 - 12.293	167.72 - 173.2	3332 - 3339	31.2 - 31.8
12.51975 - 12.52025	240 - 285	3345.8 - 3358	36.43 - 36.5
12.57675 - 12.57725	322 - 335.4	3600 - 4400	(1)

15.205(b) except as provided in paragraphs (d) and (e), the field strength of emissions appearing within these frequency bands shall not exceed the limits shown in Section 15.209. At frequencies equal to or less than 1000 MHz, compliance with the limits in Section 15.209 shall be demonstrated using measurement instrumentation employing a CISPR quasi-peak detector. Above 1000 MHz, compliance with the emission limits in Section 15.209 shall be demonstrated based on the average value of the measured emissions. The provisions in Section 15.35 apply to these measurements.

15.209( a) Except as provided elsewhere in this Subpart, the emissions from an intentional radiator shall not exceed the field strength levels specified in the following table

Frequency (MHz)	Field Strength (uV/m)	Measurement Distance (m)
0.009 - 0.490	2400/F (kHz)	300
0.490 - 1.705	24000/F (kHz)	30
1.705 - 30.0	30	30
30 – 88	100	3
88 – 216	150	3
216 – 960	200	3
Above 960	500	3

In the emission table above, the tighter limit applies at the band edges.

The level of any unwanted emissions from an intentional radiator operating under these general provisions shall not exceed the level of the fundamental emission.

The emission limits shown in the above table are based on measurements employing a CISPR quasi-peak detector except for the frequency bands 9-90 kHz, 110-490 kHz.

**Test results - Complied with requirement.**

## Test Data

### 2.5.1 Below 30 MHz

**Test equipment used (refer to List of utilized test equipment)**

LP01	CL11	TR06	
------	------	------	--

Tested Date: 21 June, 2009

Temperature: 21 °C  
 Humidity: 55 %  
 Atmos. Press: 1009 hPa

## Result

**There is no spurious emission with levels of more than 20 dB below the applicable limit**



## 2.5.2 Between 30 – 1000 MHz

### Test equipment used (refer to List of utilized test equipment)

BA04	CL11	PR03	CL23	BRF3	TR06
------	------	------	------	------	------

Tested Date: 21 June, 2009

Temperature: 21 °C  
 Humidity: 55 %  
 Atmos. Press: 1009 hPa

Operating mode: Continuous Communication (Lch: 902.9376MHz: Worst configuration)

EUT position: X-plane (Maximum position)

Measurement distance: 3 m

No.	Frequency [MHz]	Reading [dBuV]	Factor [dB/m]	Loss [dB]	Gain [dB]	Result [dBuV/m]	Limit [dBuV/m]	Margin [dB]	Antenna Polarization
1	48.738	34.6	8.8	7.7	29.7	21.4	40.0	18.6	Vert.
2	114.680	28.3	11.8	8.7	29.6	19.2	43.5	24.3	Vert.
3	136.000	24.9	11.3	9.0	29.5	15.7	43.5	27.8	Vert.
4	157.300	25.2	10.1	9.2	29.5	15.0	43.5	28.5	Vert.
5	<b>802.619</b>	<b>32.4</b>	<b>20.0</b>	<b>14.1</b>	<b>29.4</b>	<b>37.1</b>	<b>46.0</b>	<b>8.9</b>	<b>Hori.</b>

### Calculation method

The Correction Factors and RESULT are calculated as followings.

$$\text{Correction Factor [dB/m]} = \text{FACTOR [dB/m]} + \text{LOSS [dB]} - \text{GAIN [dB]}$$

$$\text{RESULT [dBuV/m]} = \text{READING [dBuV]} + \text{Correction Factor [dB/m]}$$

Sample calculation at 802.619 MHz horizontal result as follow:

$$\text{Result [dBuV/m]} = \text{Reading} + \text{C.F} = 32.4 + 20.0 + 14.1 - 29.4 = 37.1$$

$$\text{Margin} = \text{Limit} - \text{Result} = 46.0 - 37.1 = 8.9 \text{ [dB]}$$

### Graphical express of test result (30MHz-1000MHz)

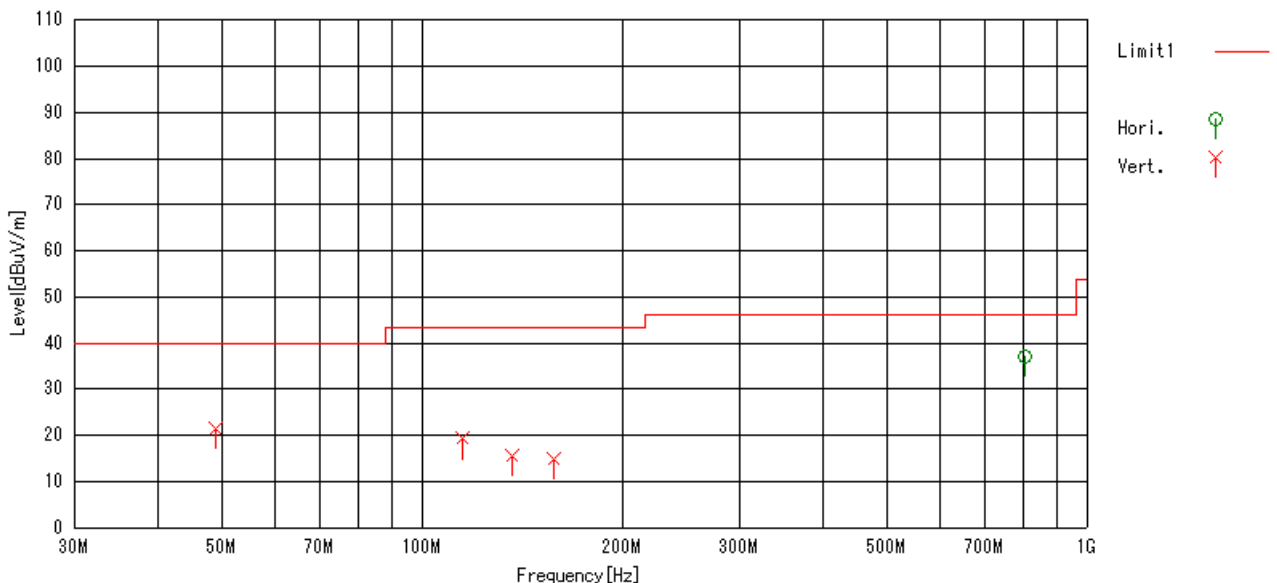

## 2.5.3 Above 1000 MHz

### Test equipment used (refer to List of utilized test equipment)

PR12	CL21	TR06	CL23	CL24	HPF2	BRF3	DH01	AC01
------	------	------	------	------	------	------	------	------

Tested Date: 21 June, 2009

Temperature: 21 °C  
 Humidity: 55 %  
 Atmos. Press: 1009 hPa

### Restricted Band Edge (Worst configuration: X plane, Horizontal)

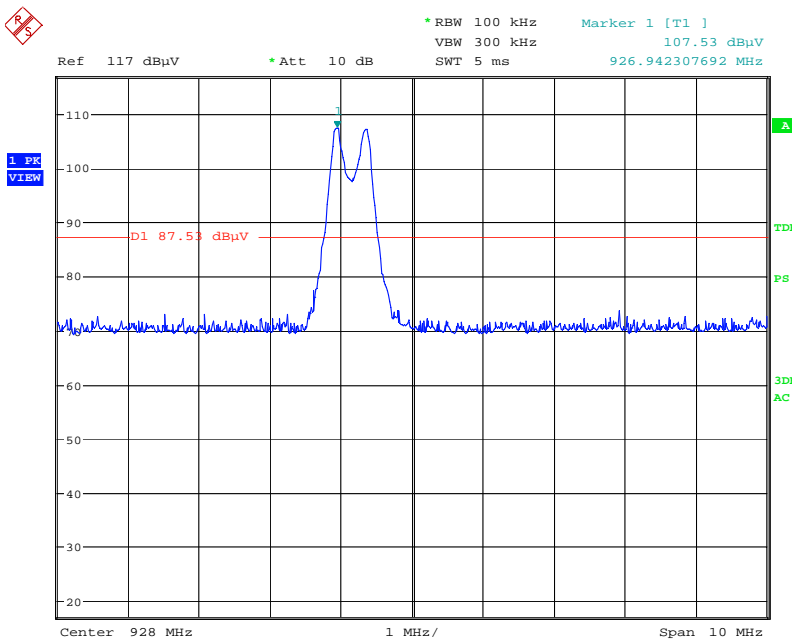
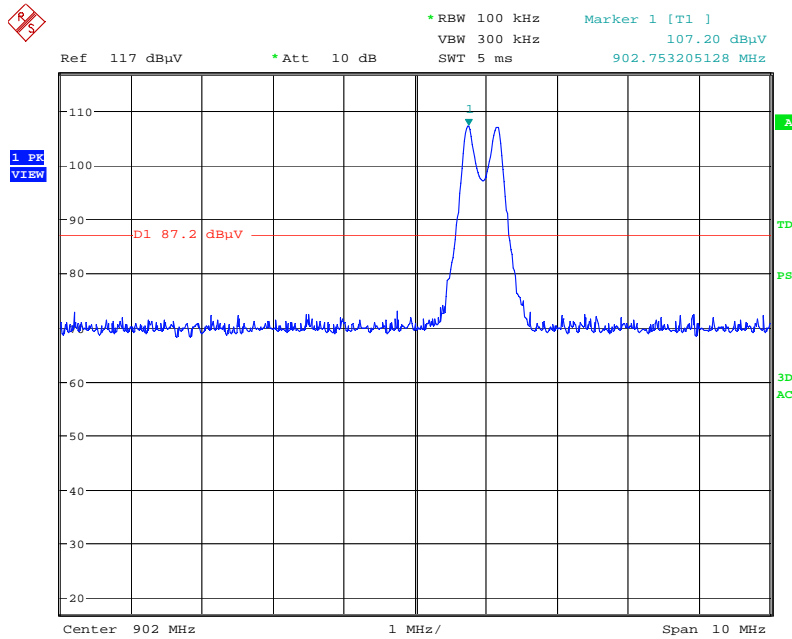

## Harmonics and Spurious Emission above 1000 MHz

Tested Date: 20 June, 2009

Temperature: 21 °C  
 Humidity: 59 %  
 Atmos. Press: 1015 hPa

Operating mode: Continuous Communication (Hch: 927.1296MHz: Worst configuration)  
 EUT position: Z-plane (Maximum position)  
 Measurement distance: 3 m

No.	Frequency [MHz]	Reading [dBuV]		C.F. [dB]	Result [dBuV/m]		Limit [dBuV/m]		Margin [dB]		Polarization
		Peak	Ave.		Peak	Ave.	Peak	Ave.	Peak	Ave.	
1	1854.268*	50.5	41.7	-7.6	42.9	-	87.3	-	44.4	-	Vert.
2	1854.299*	48.7	39.5	-7.6	41.1	-	87.3	-	46.2	-	Hori.
3	2781.761	49.3	38.4	-4.4	44.9	34.0	73.9	53.9	29.0	19.9	Vert.
4	2781.921	48.4	36.7	-4.4	44.0	32.3	73.9	53.9	29.9	21.6	Hori.
5	3709.302	47.8	36.0	-2.1	45.7	33.9	73.9	53.9	28.2	20.0	Hori.
6	4634.603	46.0	33.0	0.7	46.7	33.7	73.9	53.9	27.2	20.2	Hori.
7	5561.567*	49.6	38.2	2.9	52.5	-	87.3	-	34.8	-	Vert.
8	5561.600*	47.6	35.8	2.9	50.5	-	87.3	-	36.8	-	Hori.
<b>9</b>	<b>7418.576</b>	45.9	<b>32.5</b>	<b>5.8</b>	51.7	<b>38.3</b>	73.9	<b>53.9</b>	22.2	<b>15.6</b>	<b>Hori.</b>

Note1: This frequency is not in the restriction band therefore this spurious emission shall be at least 20 dB below that in the 100 kHz bandwidth within the band that contains the highest level of the desired power (15.247 (d)).

The radiated carrier level of each frequency is follows (RBW = 100 kHz);  
 < 107.3 dBuV/m at 927.1296 MHz

## 2.6 Transmitter AC power line conducted emissions

### Test setup

Test setup was implemented according to the method of ANSI C63.4: 2003 clause 6 “General requirements for EUT equipment arrangements and operation” and Annex H.1 “AC power line conducted emission measurements setup”.

### Test procedure

Measurement procedures were implemented according to the method of ANSI C63.4: 2003 clauses 7, clause 13.1.3 and Annex H.2 “AC power line conducted emission measurements”.

Exploratory measurements were used the spectrum analyzer to identify the frequency of the emission that has the highest amplitude relative to the limit by operating the EUT in a range of typical modes of operation, cable positions, and with a typical system equipment configuration and arrangement.

Final ac power line conducted emission measurements were performed based on the exploratory tests.

The EUT cable configuration and arrangement and mode of operation that produced the emission with the highest amplitude relative to the limit are selected for the final measurement.

When the measurement value is greater than average limitation the average detection measurements were performed.

### Applicable rule and limitation

§15.207 (a) AC power line conducted limits

Frequency of Emission (MHz)	Conducted Limit (dBuV)	
	Quasi-peak	Average
0.15-0.5	66 to 56 *	56 to 46 *
0.5-5	56	46
5-30	60	50

\* Decreases with the logarithm of the frequency.  
 The lower limit applies at the band edges.

### Test equipment used (refer to List of utilized test equipment)

TR06	PL06	LN06	CL11
------	------	------	------

**Test results - Complied with requirement.**

**Test Data**

Tested Date: 21 June, 2009

Temperature: 21 °C  
Humidity: 55 %  
Atmos. Press: 1009 hPa

Operating mode: Continuous Communication (Lch: 902.9376MHz: Worst configuration)

No.	Frequency [MHz]	Reading		C.F. [dB]	Result		Limit		Margin		PHASE
		QP [dBuV]	AV [dBuV]		QP [dBuV]	AV [dBuV]	QP [dBuV]	AV [dBuV]	QP [dB]	AV [dB]	
1	0.378	47.3	41.2	0.3	47.6	41.5	58.3	48.3	10.7	6.8	N
2	0.380	46.2	42.2	0.3	46.5	42.5	58.3	48.3	11.8	5.8	L
<b>3</b>	<b>0.755</b>	48.0	<b>41.2</b>	<b>0.3</b>	48.3	<b>41.5</b>	56.0	<b>46.0</b>	7.7	<b>4.5</b>	<b>N</b>
4	0.755	47.3	41.1	0.3	47.6	41.4	56.0	46.0	8.4	4.6	L
5	1.131	44.9	35.6	0.3	45.2	35.9	56.0	46.0	10.8	10.1	L
6	1.132	46.3	37.9	0.3	46.6	38.2	56.0	46.0	9.4	7.8	N

The power line conducted emission voltage is calculated by adding the LISN factor and Cable loss attenuation from the measured reading. The calculation is as follows:

Result = Reading + C. F  
where C.F = LISN Factor + Cable Loss [dB]

Sample calculation at 0.755 MHz AV result as follow:

Result [dBuV] = Reading + C.F = 41.2 + 0.3 = 41.5 [dBuV]  
Margin = Limit – Result = 46.0 – 41.5 = 4.5 [dB]

## Graphical express of test result (0.15 MHz-30MHz)

### AC Power line conducted emission. (Phase N)

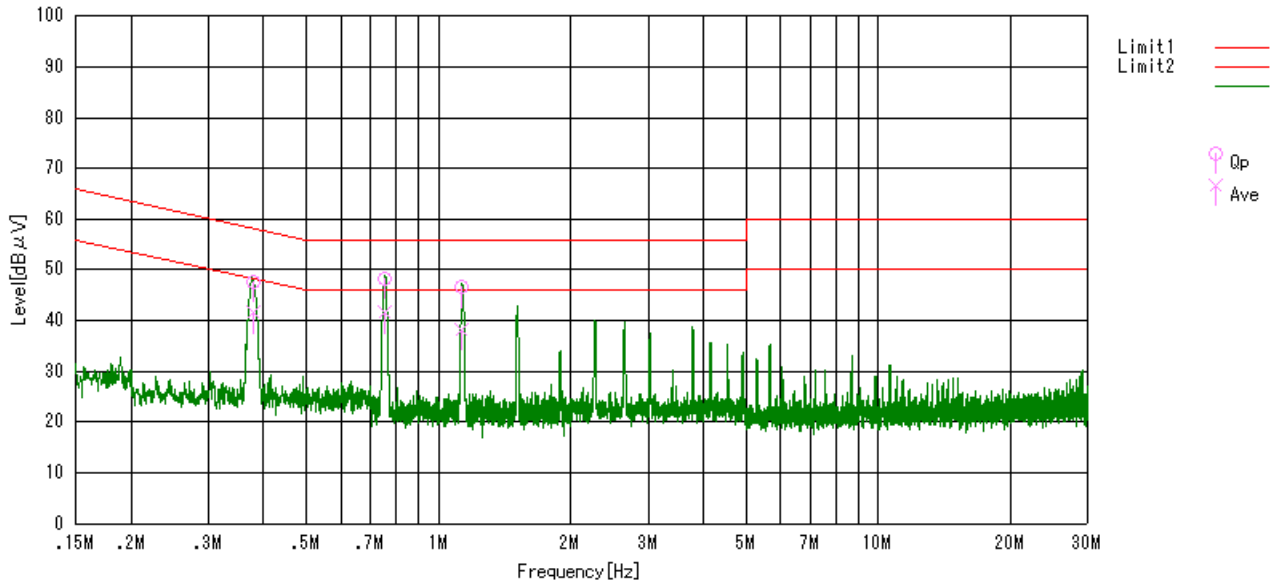

### AC Power line conducted emission. (Phase L)

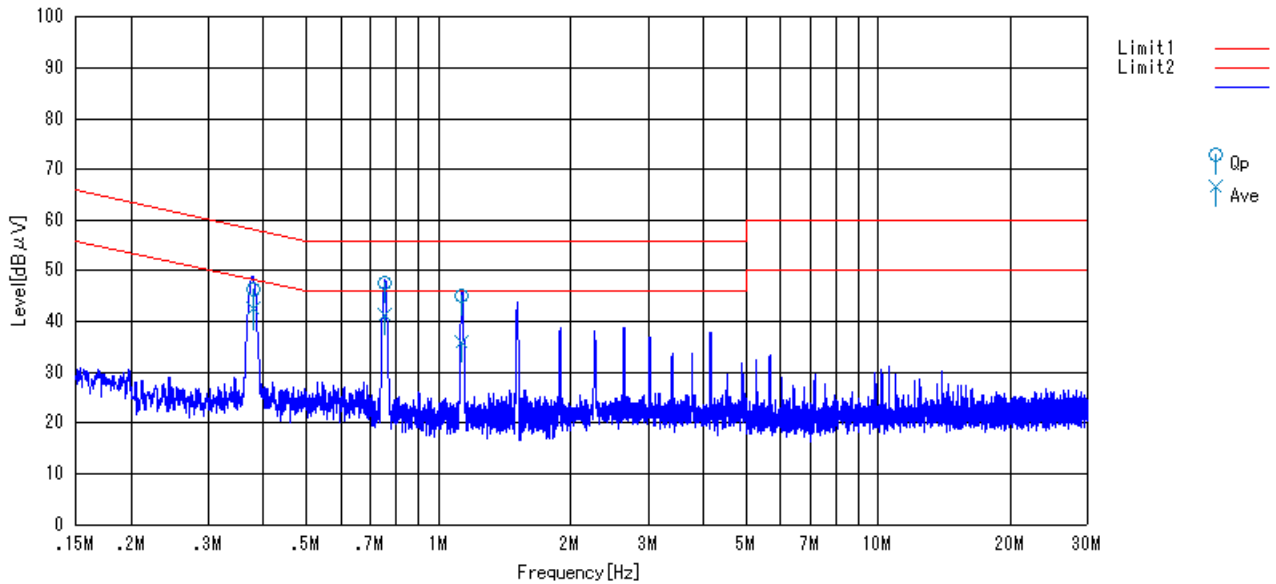

## 2.7 Receiver Radiated spurious emissions

Test setup - Same as clause 2.5

Test procedure - Same as clause 2.5

### Applicable rule and limitation at 3m

§15.109 radiated emission limitation

Frequency (MHz)	Measurement Distance (m)	Field Strength (uV/m)	Field Strength (dBuV/m)
30 – 88	3	100	40.0
88 – 216	3	150	43.5
216 – 960	3	200	46.0
Above 960	3	500	53.9

In the emission table above, the tighter limit applies at the band edges.

The emission limits shown in the above table are based on measurements employing a CISPR quasi-peak detector. Radiated emission limits in the above bands are based on measurements employing an average detector.

Test results - Complied with requirement.

### 2.7.1 Between 30 – 1000 MHz

#### Test equipment used (refer to List of utilized test equipment)

BA04	CL11	PR03	TR06
------	------	------	------

#### Test Data

Tested Date: 21 June, 2009

Temperature: 21 °C  
 Humidity: 55 %  
 Atmos. Press: 1009 hPa

Operating mode: Continuous Receiving (Hch: 927.1296MHz: Worst configuration)

EUT position: X-plane (Maximum position)

Measurement distance: 3 m

No.	Frequency [MHz]	Reading [dBuV]	Factor [dB/m]	Loss [dB]	Gain [dB]	Result [dBuV/m]	Limit [dBuV/m]	Margin [dB]	Antenna Polarization
1	48.520	34.4	8.9	7.6	29.7	21.2	40.0	18.8	Vert.
2	115.500	28.0	11.9	8.5	29.6	18.8	43.5	24.7	Vert.
3	<b>802.619</b>	<b>31.5</b>	<b>20.0</b>	<b>13.6</b>	<b>29.4</b>	<b>35.7</b>	<b>46.0</b>	<b>10.3</b>	<b>Hori.</b>

#### Calculation method

The Correction Factors and RESULT are calculated as followings.

$$\text{Correction Factor [dB/m]} = \text{FACTOR [dB/m]} + \text{LOSS [dB]} - \text{GAIN [dB]}$$

$$\text{RESULT [dBuV/m]} = \text{READING [dBuV]} + \text{Correction Factor [dB/m]}$$

Sample calculation at 802.619 MHz horizontal result as follow:

$$\text{Result [dBuV/m]} = \text{Reading} + \text{C.F} = 31.5 + 20.0 + 13.6 - 29.4 = 35.7$$

$$\text{Margin} = \text{Limit} - \text{Result} = 46.0 - 35.7 = 10.3 \text{ [dB]}$$

## Graphical express of test result (30MHz-1000MHz)

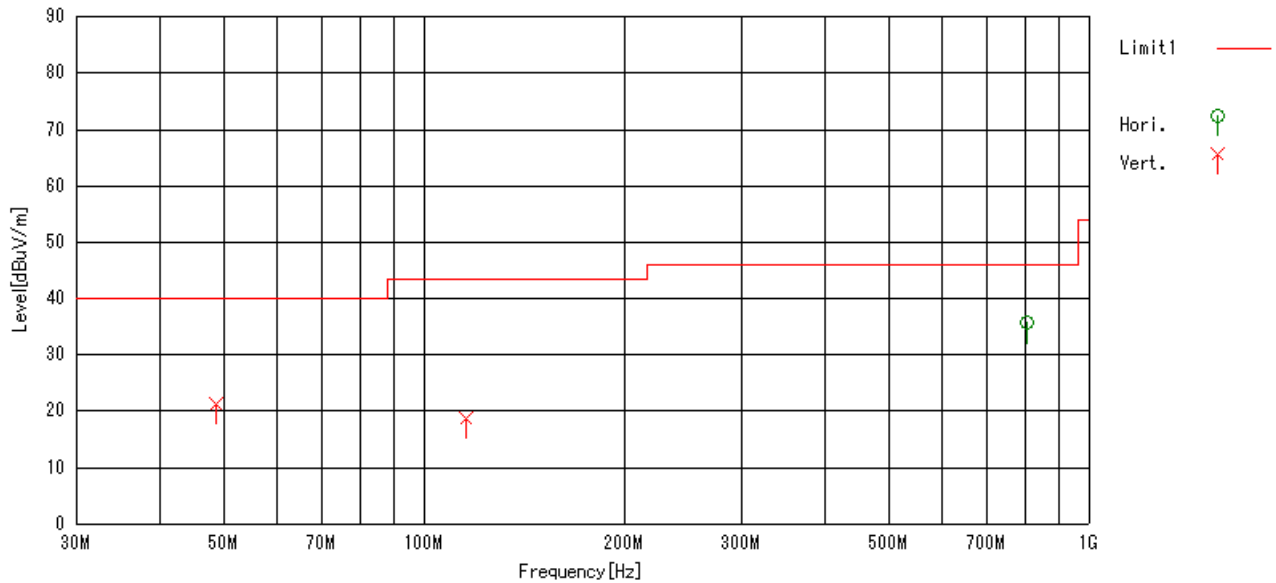

### 2.7.2 Above 1000 MHz

#### Test equipment used (refer to List of utilized test equipment)

PR12	TR06	CL23	CL24	DH01		
------	------	------	------	------	--	--

Tested Date: 20 June, 2009

Temperature: 21 °C  
 Humidity: 59 %  
 Atmos. Press: 1015 hPa

Operating mode: Continuous Receiving (Hch: 927.1296MHz: Worst configuration)  
 EUT position: X-plane (Maximum position)  
 Measurement distance: 3 m

There are no spurious emissions other than listed below;

No.	Frequency [MHz]	Reading [dBuV]	C.F. [dB/m]	Result [dBuV/m]	Limit [dBuV/m]	Margin [dB]	Antenna Polarization
1	1887.096	33.7	-7.6	26.1	53.9	27.8	Hori.

C. F. [dB/m] = FACTOR [dB/m] + LOSS [dB] – GAIN [dB]

#### Calculation method

The RESULT is calculated as followings.

$$\text{RESULT [dBuV/m]} = \text{READING [dBuV]} + \text{C.F. [dB/m]}$$



## 2.8 Receiver AC power line conducted emissions

Test setup - Same as clause 2.6

Test procedure - Same as clause 2.6

Applicable rule and limitation

§15.107 (a) AC power line conducted limits

Frequency of Emission (MHz)	Conducted Limit (dBuV)	
	Quasi-peak	Average
0.15-0.5	66 to 56 *	56 to 46 *
0.5-5	56	46
5-30	60	50

\* Decreases with the logarithm of the frequency.  
 The lower limit applies at the band edges.

Test equipment used (refer to List of utilized test equipment)

TR06	PL06	LN06	CL11
------	------	------	------

Test results - Complied with requirement.

Test Data

Tested Date: 21 June, 2009

Temperature: 21 °C  
 Humidity: 55 %  
 Atmos. Press: 1009 hPa

Operating mode: Continuous Receiving (Lch: 902.9376MHz: Worst configuration)

No.	Frequency [MHz]	Reading		C.F. [dB]	Result		Limit		Margin		PHASE
		QP [dBuV]	AV [dBuV]		QP [dBuV]	AV [dBuV]	QP [dBuV]	AV [dBuV]	QP [dB]	AV [dB]	
1	0.398	47.6	41.5	0.3	47.9	41.8	57.9	47.9	10.0	6.1	N
2	<b>0.399</b>	48.1	<b>43.5</b>	<b>0.3</b>	48.4	<b>43.8</b>	57.9	<b>47.9</b>	9.5	<b>4.1</b>	<b>L</b>
3	0.796	46.6	38.6	0.3	46.9	38.9	56.0	46.0	9.1	7.1	L
4	0.797	48.0	41.1	0.3	48.3	41.4	56.0	46.0	7.7	4.6	N
5	1.196	45.3	36.7	0.4	45.7	37.1	56.0	46.0	10.3	8.9	N
6	1.196	44.8	35.9	0.4	45.2	36.3	56.0	46.0	10.8	9.7	L

The power line conducted emission voltage is calculated by adding the LISN factor and Cable loss attenuation from the measured reading. The calculation is as follows:

Result = Reading + C. F  
 where C.F = LISN Factor + Cable Loss [dB]

Sample calculation at 0.399 MHz AV result as follow:

Result [dBuV] = Reading + C.F = 43.5 + 0.3 = 43.8 [dBuV]  
 Margin = Limit – Result = 47.9 – 43.8 = 4.1 [dB]

## Graphical express of test result (0.15 MHz-30MHz)

### AC Power line conducted emission. (Phase N)

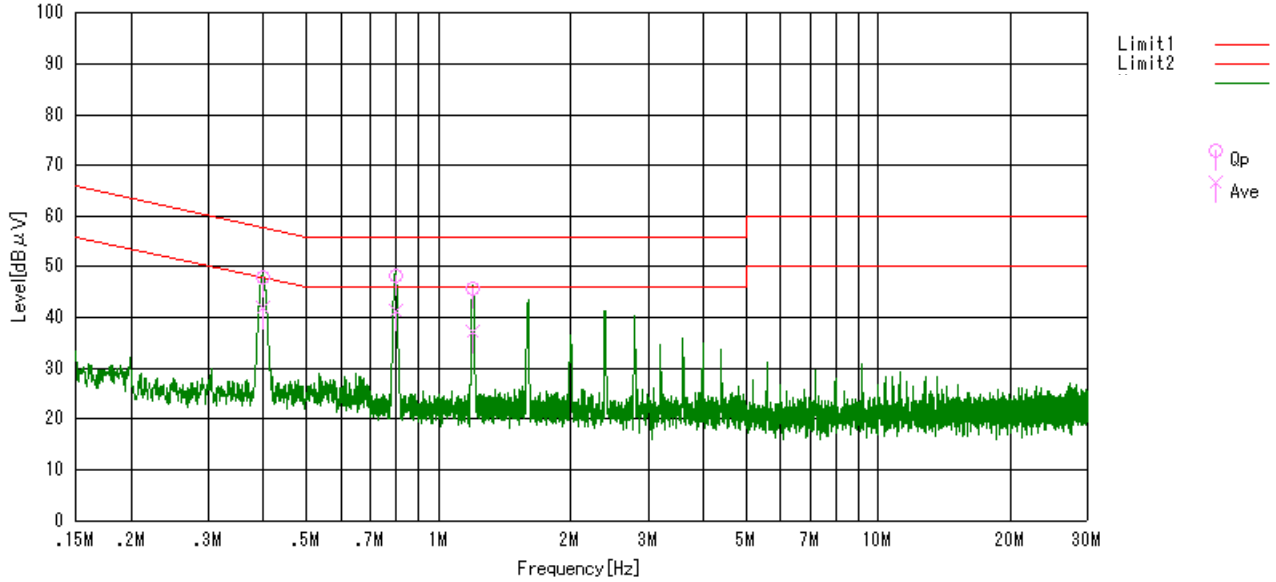

### AC Power line conducted emission. (Phase L)

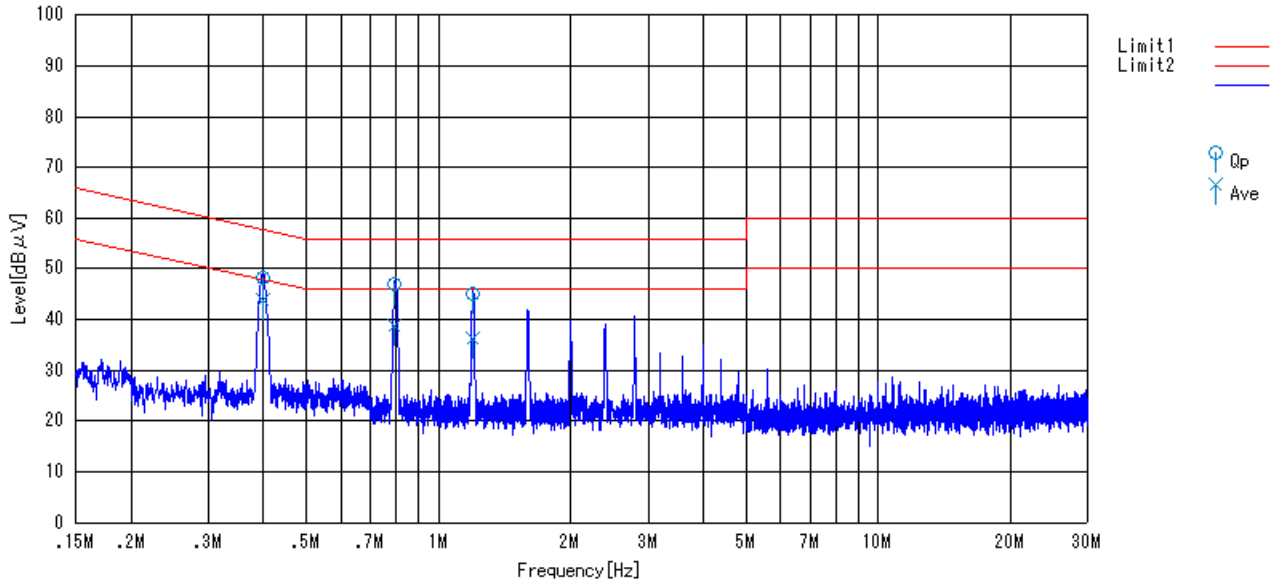

## 2.9 Maximum Permissible Exposure (Exposure of Humans to RF Fields)

### Limitation

15.247(i) systems operating under the provisions of this section shall be operated in a manner that ensures that the public is not exposed to radio frequency energy levels in excess of the Commission's guidelines.

See 1.1307(b) (1) of this Chapter.

1.1310 The criteria of "General Population/ Uncontrolled Exposure" listed in the below table shall be used to evaluate the environmental impact of human exposure to radio-frequency radiation as specified in 1.1307(b), except in the case of portable devices which shall be evaluated according to the provisions of 2.1093 of this chapter.

### Limits for General Population/Uncontrolled Exposure

Frequency Range (MHz)	Electric Field Strength (E) (V/m)	Magnetic Field Strength (H) (A/m)	Power Density (S) (mW/cm <sup>2</sup> )	Averaging Time (minutes)
0.3-1.34	614	1.63	(100)*	30
1.34-30	824/f	2.19/f	(180/f <sup>2</sup> )*	30
30-300	27.5	0.073	0.2	30
300-1500	--	--	f/1500	30
1500-100,000	--	--	1.0	30

f = frequency in MHz

\*Plane-wave equivalent power density

NOTE 2: *General population/uncontrolled* exposures apply in situations in which the general public may be exposed, or in which persons that are exposed as a consequence of their employment may not be fully aware of the potential for exposure or can not exercise control over their exposure.

### The MPE distance calculations:

The Maximum Permissible Exposure (MPE) distance between the EUT's antenna and human body is calculated in accordance with FCC OET Bulletin 65 and Safety Code 6 of IC.

The MPE distance where the exposure level reaches the permitted exposure level can be calculated as below;

$$S = P * G / 4\pi R^2$$

Rearranging terms to calculate the MPE Distance

$$R = (P * G / 4\pi S)^{1/2}$$

Where:

**R = MPE Distance in cm**

**P = Power in dBm (5.22 mW (927.1296MHz), Refer to page 9 in this report)**

**G = Antenna Gain in numeric**

**(1 = 0dBi, Max. Antenna Gain)**

**S = Power Density Limit in mW/cm<sup>2</sup>**

**(0.62 mW/cm<sup>2</sup>, Max. permissible exposure limit above)**

Then MPE Distance is 0.819 cm.

**Test results - Complied with requirement.**

## 4 List of utilized test equipment/ calibration

RFT ID No.	Kind of Equipment and Precision	Manufacturer	Model No.	Serial Number	Calibration Date	Calibrated until
AC01	Anechoic Chamber (1st test room)	JSE	203397C	-	2008/07/04	2009/07/31
BA04	Biological Antenna	SCHAFFNER	CA2855	2903	2009/01/06	2010/01/31
CL11	Antenna Cable for RE	RFT	-	-	2009/04/13	2010/04/30
CL21	RF Cable 0.5m	SUCOFLEX	SF104PE	48772/4PE	2008/06/10	2009/06/30
CL22	RF Cable 2.0m	SUCOFLEX	SF104	274755/4	2008/06/10	2009/06/30
CL23	RF Cable 0.5m	SUCOFLEX	SF104PE	48773/4PE	2008/06/10	2009/06/30
CL24	RF Cable 5.0m	SUCOFLEX	SF104PE	48775/4PE	2008/06/10	2009/06/30
LN06	LISN	Kyoritsu	KNW-407	8-1773-3	2009/05/26	2010/05/31
PL06	Pulse Limiter	PMM	PL-01	0000J10109	2009/01/05	2010/01/31
PR03	Pre. Amplifier	Anritsu	MH648A	M41984	2009/05/26	2010/05/31
PR12	Pre. Amplifier (1-26G)	Agilent Technologies	8449B	3008A02513	2009/01/13	2010/01/31
HPF2	High Pass Filter (900MHz)	M-City	HPF0900-01	RF0003-01	2008/06/09	2009/06/30
BRF3	Band Reject Filter (GSM900)	M-City	BRF0897-03	RF0005	2009/04/08	2010/04/30
TR06	Test Receiver (F/W : 3.93 SP2)	Rohde & Schwarz	ESU26	100002	2008/09/02	2009/09/01
DH01	DRG Horn Antenna	A.H. Systems	SAS-571	785	2008/01/31	2010/01/29

The measuring equipment, which was utilized in performing the tests documented herein, has been calibrated in accordance with the manufacturer's recommendations for utilizing calibration equipment, which is traceable to recognized national standards.