

Working Principle

CC2500 is the transceiver of Wireless Guitar Controller for PS2. This device was designed to be used with the popular Guitar Hero and Guitar Hero 2 games available for the PS2 entertainment console. At the same time, this two devices operate as a transceiver by FSK modulation and they establish a communication link as below figure.

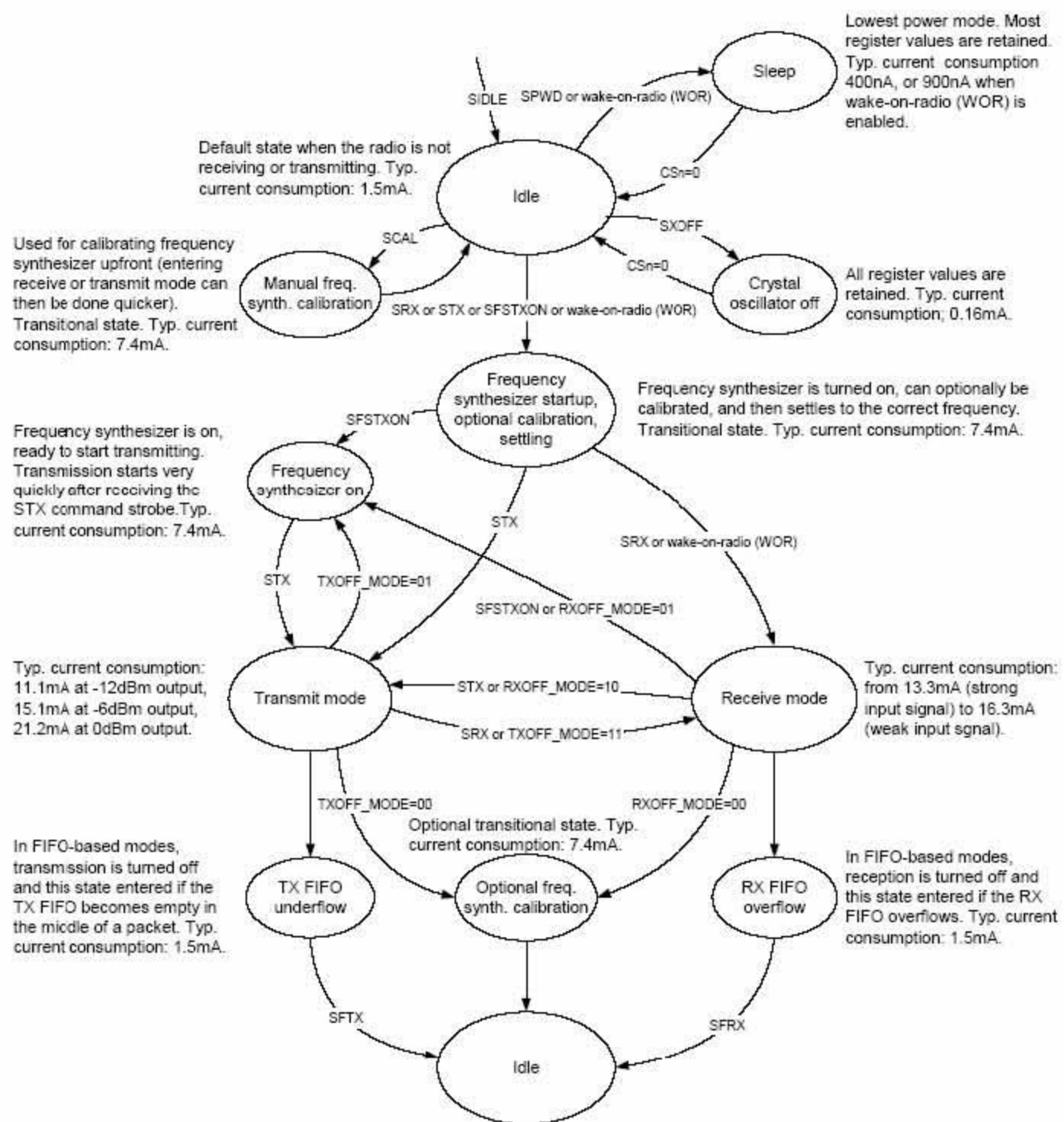

The RF transceiver is integrated with a highly configurable baseband modem. The modem supports various modulation formats and has a configurable data rate between 1.2-500 kbps. The communication range can be increased by enabling a Forward Error Correction option, which is integrated in the modem.

CC2500 provides extensive hardware support for packet handling, data buffering, burst transmissions, clear channel assessment, link quality indication and wake-on-radio.

The main operating parameters and the 64-byte transmit/receive FIFOs of CC2500 can be controlled via an SPI interface. In a typical system, the CC2500 will be used together with a microcontroller and a few additional passive components.

CC2500 is based on Chipcon's SmartRF 04 technology in 0.18 um CMOS.

6 Circuit Description

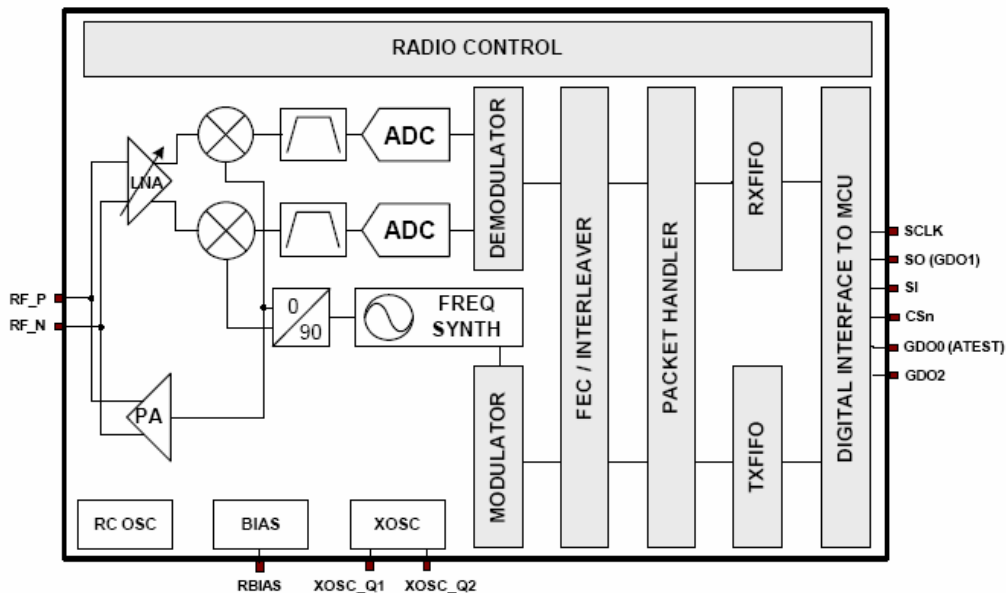

Figure 2: **CC2500** simplified block diagram

A simplified block diagram of **CC2500** is shown in Figure 2.

CC2500 features a low-IF receiver. The received RF signal is amplified by the low-noise amplifier (LNA) and down-converted in quadrature (I and Q) to the intermediate frequency (IF). At IF, the I/Q signals are digitised by the ADCs. Automatic gain control (AGC), fine channel filtering, demodulation bit/packet synchronization is performed digitally.

The transmitter part of **CC2500** is based on direct synthesis of the RF frequency.

The frequency synthesizer includes a completely on-chip LC VCO and a 90 degrees

phase shifter for generating the I and Q LO signals to the down-conversion mixers in receive mode.

A crystal is to be connected to XOSC_Q1 and XOSC_Q2. The crystal oscillator generates the reference frequency for the synthesizer, as well as clocks for the ADC and the digital part.

A 4-wire SPI serial interface is used for configuration and data buffer access.

The digital baseband includes support for channel configuration, packet handling and data buffering.

7 Application Circuit

Only a few external components are required for using the **CC2500**. The recommended application circuit is shown in Figure 3. The external components are described in Table 14, and typical values are given in Table 15. Note that the PCB antenna alternative indicated in Figure 3 is preliminary and subject to changes. Performance for the PCB antenna

alternative will be included in future revisions of this data sheet.

Bias resistor

The bias resistor R171 is used to set an accurate bias current.

Balun and RF matching

C122, C132, L121 and L131 form a balun that converts the differential RF signal on **CC2500** to a single-ended RF signal (C121 and C131 are also needed for DC blocking). Together with an appropriate LC network, the balun components also transform the impedance to match a 50 Ω antenna (or cable). Component values for the RF balun and LC network are easily found using the SmartRF® Studio software. Suggested values are listed in Table 15.

Crystal

The crystal oscillator uses an external crystal with two loading capacitors (C81 and C101). See Section 26 on page 44 for details.

Power supply decoupling

The power supply must be properly decoupled close to the supply pins. Note that decoupling capacitors are not shown in the application circuit. The placement and the size of the decoupling capacitors are very important to achieve the optimum performance. Chipcon provides a reference design that should be followed closely.

Component	Description
C51	Decoupling capacitor for on-chip voltage regulator to digital part
C81/C101	Crystal loading capacitors, see Section 26 on page 44 for details
C121/C131	RF balun DC blocking capacitors
C122/C132	RF balun/matching capacitors
C123/C124	RF LC filter/matching capacitors
L121/L131	RF balun/matching inductors (inexpensive multi-layer type)
L122	RF LC filter inductor (inexpensive multi-layer type)
R171	Resistor for internal bias current reference
XTAL	26-27 MHz crystal, see Section 26 on page 44 for details

Table 14: Overview of external components (excluding supply decoupling capacitors)

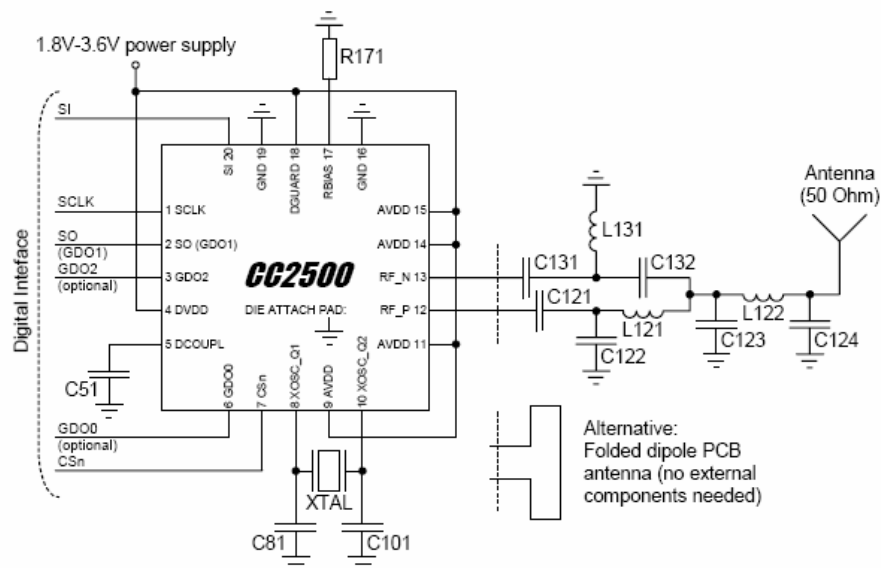

Figure 3: Typical application and evaluation circuit (excluding supply decoupling capacitors)