

FCC Test Report

FCC ID : SQG-SU60SOMC
Equipment : 802.11ac Professional Wi-Fi + BT5.0 Module
Model No. : SU60-SOMC (453-00003),
SU60-SOMC-2G (453-00004)
(please refer to section 1.1.1 for more details.)
Brand Name : Laird
Applicant : Laird Technologies
Address : W66N220 Commerce Court, Cedarburg,
Wisconsin 53012, USA
Standard : 47 CFR FCC Part 15.407
Received Date : Apr. 11, 2018
Tested Date : Jun. 28 ~ Sep. 18, 2018

We, International Certification Corp., would like to declare that the tested sample has been evaluated and in compliance with the requirement of the above standards. The test results contained in this report refer exclusively to the product. It may be duplicated completely for legal use with the approval of the applicant. It shall not be reproduced except in full without the written approval of our laboratory.

Reviewed by:



Along Chen / Assistant Manager

Approved by:



Gary Chang / Manager



Table of Contents

1	GENERAL DESCRIPTION	5
1.1	Information.....	5
1.2	Test Setup Chart	12
1.3	The Equipment List	13
1.4	Testing Applied Standards	14
1.5	Measurement Uncertainty	14
2	TEST CONFIGURATION	15
2.1	Testing Condition	15
2.2	The Worst Test Modes and Channel Details	16
3	TRANSMITTER TEST RESULTS.....	18
3.1	Conducted Emissions.....	18
3.2	Emission Bandwidth	23
3.3	RF Output Power.....	43
3.4	Peak Power Spectral Density.....	51
3.5	Transmitter Radiated and Band Edge Emissions	72
3.6	Frequency Stability.....	427
4	TEST LABORATORY INFORMATION	430

Release Record

Report No.	Version	Description	Issued Date
FR841101AN	Rev. 01	Initial issue	Nov. 19, 2018

Summary of Test Results

FCC Rules	Test Items	Measured	Result
15.207	Conducted Emissions	[dBuV]: 0.159MHz 52.00 (Margin -13.52dB) - QP	Pass
15.407(b) 15.209	Radiated Emissions	[dBuV/m at 3m]: 5470.00MHz 73.88 (Margin -0.12dB) - PK	Pass
15.407(a)	Emission Bandwidth	Meet the requirement of limit	Pass
15.407(e)	6dB bandwidth	Meet the requirement of limit	Pass
15.407(a)	RF Output Power	Max Power [dBm]: 5150~5250MHz: 20.89 5250~5350MHz: 19.03 5470~5725MHz: 20.53 5725~5850MHz: 20.36	Pass
15.407(a)	Peak Power Spectral Density	Meet the requirement of limit	Pass
15.407(g)	Frequency Stability	Meet the requirement of limit	Pass
15.203	Antenna Requirement	Meet the requirement of limit	Pass

1 General Description

1.1 Information

1.1.1 Product Details

The following models are provided to this EUT.

Brand Name	Model Name	Product Name	Description
Laird	SU60-SOMC (453-00003)	802.11ac Professional Wi-Fi + BT5.0 Module	2G/1G MCP
	SU60-SOMC-2G (453-00004)		4G/2G MCP
✦ The above models, both options were assessed and SU60-SOMC-2G (453-00004) was found to be worst case and was selected for the final testing.			

1.1.2 Specification of the Equipment under Test (EUT)

RF General Information					
Frequency Range (MHz)	IEEE Std. 802.11	Ch. Freq. (MHz)	Channel Number	Transmit Chains (N _{TX})	Data Rate / MCS
5150-5250 5250-5350 5470-5725 5725-5850	a	5180-5240	36-48 [4]	1	6-54 Mbps
		5260-5320 5500-5720 5745-5825	52-64 [4] 100-144 [12] 149-165 [5]	2	6-54 Mbps
5150-5250 5250-5350 5470-5725 5725-5850	n (HT20)	5180-5240	36-48 [4]	1	MCS 0-7
		5260-5320	52-64 [4]	2	MCS 0-7
		5500-5720 5745-5825	100-144 [12] 149-165 [5]	2	MCS 8-15
5150-5250 5250-5350 5470-5725 5725-5850	n (HT40)	5190-5230	38-46 [2]	1	MCS 0-7
		5270-5310	54-62 [2]	2	MCS 0-7
		5510-5710 5755-5795	102-142 [6] 151-159 [2]	2	MCS 8-15
5150-5250 5250-5350 5470-5725 5725-5850	ac (VHT20)	5180-5240	36-48 [4]	1	MCS 0-9
		5260-5320 5500-5720 5745-5825	52-64 [4] 100-144 [12] 149-165 [5]	2	
5150-5250 5250-5350 5470-5725 5725-5850	ac (VHT40)	5190-5230	38-46 [2]	1	MCS 0-9
		5270-5310 5510-5710 5755-5795	54-62 [2] 102-142 [6] 151-159 [2]	2	
5150-5250 5250-5350 5470-5725 5725-5850	ac (VHT80)	5210	42 [1]	1	MCS 0-9
		5290 5530~5690 5775	58 [1] 106-138 [3] 155 [1]	2	

Note 1: RF output power specifies that Maximum Conducted Output Power.
 Note 2: 802.11a/n/ac uses a combination of OFDM-BPSK, QPSK, 16QAM, 64QAM, 256QAM modulation.
 Note 3: The device supports TX antenna diversity function. The conducted power of single chain is same for 1TX and 2TX operating mode. Therefore, Ant1 + Ant 2 configuration is chosen for final testing.

1.1.3 Antenna Details

Brand	Model	Type	Connector	Operating Frequency (MHz) / Gain (dBi)			
				5150~5250	5250~5350	5470~5725	5725~5850
LSR	001-0009	Dipole	IPEX U.FL	2			
Laird	NanoBlade-IP04	PCB Dipole	IPEX U.FL	3.9		4	4
Laird	MAF95310 Mini NanoBlade Flex	PCB Dipole	IPEX U.FL	3.38			
LSR	FlexPIFA 001-0016	PIFA	IPEX U.FL	3			
Ethertronics	WLAN_1000146	Magnetic Dipole	IPEX U.FL	3.5			
Laird	MIMO FlexPIFA Antenna	PIFA	IPEX U.FL	3			
LSR	001-0009 (with filter)	Dipole	IPEX U.FL	2			

1.1.4 Power Supply Type of Equipment under Test (EUT)

Power Supply Type	3.3Vdc from host
--------------------------	------------------

1.1.5 Accessories

Accessories		
No.	Equipment	Description
1	AC Adapter	Brand Name: I.T.E POWER SUPPLY Model Name: MU12AY120100-A1 Power Rating: I/P: 100-240Vac, 50/60Hz, 0.3A O/P: 12Vdc, 1A Power Line: 1.48m non-shielded cable w/o core

1.1.6 Channel List

802.11 a / HT20 / VHT20		HT40 / VHT40	
Channel	Frequency(MHz)	Channel	Frequency(MHz)
36	5180	38	5190
40	5200	46	5230
44	5220	54	5270
48	5240	62	5310
52	5260	102	5510
56	5280	110	5550
60	5300	118	5590
64	5320	126	5630
100	5500	134	5670
104	5520	142	5710
108	5540	151	5755
112	5560	159	5795
116	5580	VHT80	
120	5600	42	5210
124	5620	58	5290
128	5640	106	5530
132	5660	122	5610
136	5680	138	5690
140	5700	155	5775
144	5720	---	---
149	5745	---	---
153	5765	---	---
157	5785	---	---
161	5805	---	---
165	5825	---	---

1.1.7 Test Tool and Duty Cycle

Test Tool	Putty, Version: 0.60.0.0		
Duty Cycle and Duty Factor	Mode	Duty cycle (%)	Duty factor (dB)
	11a	100.00%	0.00
	VHT20	100.00%	0.00
	VHT40	100.00%	0.00
	VHT80	100.00%	0.00

1.1.8 Power Setting

For Frequency band 5150-5250 MHz		
Modulation Mode	Test Frequency (MHz)	Power Set
11a	5180	default
11a	5200	default
11a	5240	default
HT20	5180	default
HT20	5200	default
HT20	5240	default
HT40	5190	default
HT40	5230	default
VHT20	5180	default
VHT20	5200	default
VHT20	5240	default
VHT40	5190	default
VHT40	5230	default
VHT80	5210	default

For Frequency band 5250~5350 MHz		
Modulation Mode	Test Frequency (MHz)	Power Set
11a	5260	default
11a	5300	default
11a	5320	default
HT20	5260	default
HT20	5300	default
HT20	5320	default
HT40	5270	default
HT40	5310	default
VHT20	5260	default
VHT20	5300	default
VHT20	5320	default
VHT40	5270	default
VHT40	5310	default
VHT80	5290	default

For Frequency band 5470~5725 MHz		
Modulation Mode	Test Frequency (MHz)	Power Set
11a	5500	default
11a	5580	default
11a	5700	default
HT20	5500	default
HT20	5580	default
HT20	5700	default
HT40	5510	default
HT40	5550	default
HT40	5670	default
VHT20	5500	default
VHT20	5580	default
VHT20	5700	default
VHT40	5510	default
VHT40	5590	default
VHT40	5670	default
VHT80	5530	default
VHT80	5610	default

Channel that extends across the 5.725 GHz boundary

For Frequency band 5470~5725 MHz		
Modulation Mode	Test Frequency (MHz)	Power Set
11a	5720	default
HT20	5720	default
HT40	5710	default
VHT20	5720	default
VHT40	5710	default
VHT80	5690	default

For Frequency band 5725~5850 MHz		
Modulation Mode	Test Frequency (MHz)	Power Set
11a	5745	default
11a	5785	default
11a	5825	default
HT20	5745	default
HT20	5785	default
HT20	5825	default
HT40	5755	default
HT40	5795	default
VHT20	5745	default
VHT20	5785	default
VHT20	5825	default
VHT40	5755	default
VHT40	5795	default
VHT80	5775	default

1.2 Test Setup Chart

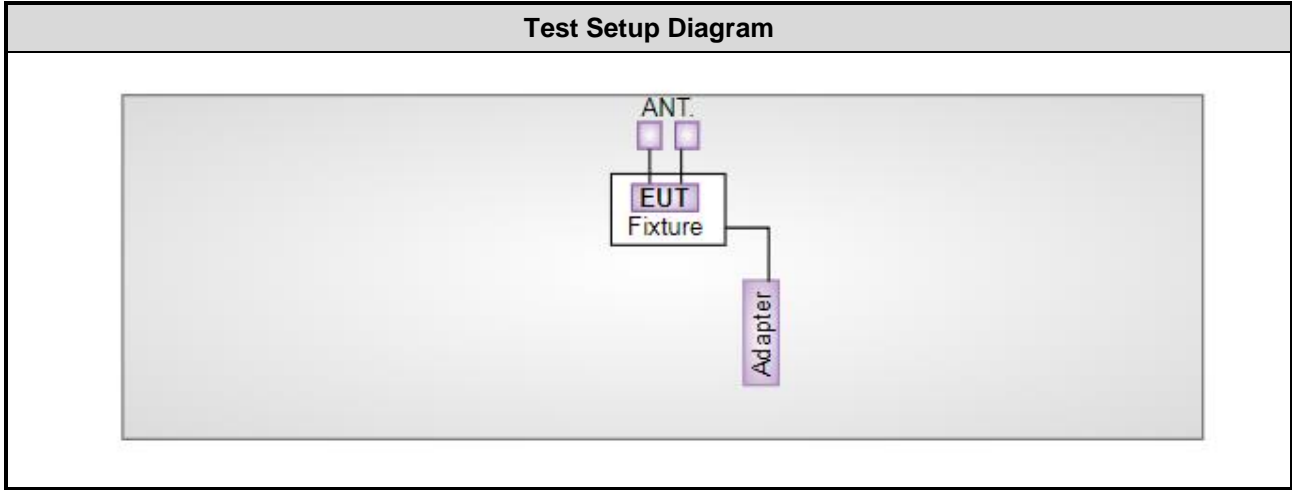

1.3 The Equipment List

Test Item	Conducted Emission				
Test Site	Conduction room 1 / (CO01-WS)				
Tested Date	Sep. 18, 2018				
Instrument	Manufacturer	Model No.	Serial No.	Calibration Date	Calibration Until
Receiver	R&S	ESR3	101657	Jan. 05, 2018	Jan. 04, 2019
LISN	SCHWARZBECK	Schwarzbeck 8127	8127-667	Nov. 13, 2017	Nov. 12, 2018
RF Cable-CON	EMC	EMCCFD300-BM-BM-6000	50821	Dec. 18, 2017	Dec. 17, 2018
Measurement Software	AUDIX	e3	6.120210k	NA	NA
Note: Calibration Interval of instruments listed above is one year.					

Test Item	Radiated Emission				
Test Site	966 chamber1 / (03CH01-WS)				
Tested Date	Jun. 28 ~ Jul. 13, 2018				
Instrument	Manufacturer	Model No.	Serial No.	Calibration Date	Calibration Until
Spectrum Analyzer	R&S	FSV40	101498	Dec. 04, 2017	Dec. 03, 2018
Receiver	R&S	ESR3	101658	Nov. 20, 2017	Nov. 19, 2018
Bilog Antenna	SCHWARZBECK	VULB9168	VULB9168-522	Jul. 25, 2017	Jul. 24, 2018
Horn Antenna 1G-18G	SCHWARZBECK	BBHA 9120 D	BBHA 9120 D 1096	Dec. 20, 2017	Dec. 19, 2018
Horn Antenna 18G-40G	SCHWARZBECK	BBHA 9170	BBHA 9170517	Nov. 23, 2017	Nov. 22, 2018
Loop Antenna	R&S	HFH2-Z2	100330	Nov. 13, 2017	Nov. 12, 2018
Loop Antenna Cable	KOAX KABEL	101354-BW	101354-BW	Dec. 07, 2017	Dec. 06, 2018
Preamplifier	EMC	EMC02325	980225	Jul. 28, 2017	Jul. 27, 2018
Preamplifier	Agilent	83017A	MY39501308	Oct. 06, 2017	Oct. 05, 2018
Preamplifier	EMC	EMC184045B	980192	Aug. 22, 2017	Aug. 21, 2018
RF Cable	HUBER+SUHNER	SUCOFLEX104	MY16140/4	May 09, 2018	May 08, 2019
RF Cable	HUBER+SUHNER	SUCOFLEX104	MY16019/4	Dec. 07, 2017	Dec. 06, 2018
RF Cable	HUBER+SUHNER	SUCOFLEX104	MY16139/4	Dec. 07, 2017	Dec. 06, 2018
LF cable 1M	EMC	EMCCFD400-NM-N M-1000	16052	Dec. 07, 2017	Dec. 06, 2018
LF cable 3M	Woken	CFD400NL-LW	CFD400NL-001	Dec. 07, 2017	Dec. 06, 2018
LF cable 10M	Woken	CFD400NL-LW	CFD400NL-002	Dec. 07, 2017	Dec. 06, 2018
Measurement Software	AUDIX	e3	6.120210g	NA	NA
Note: Calibration Interval of instruments listed above is one year.					

Test Item	RF Conducted				
Test Site	(TH01-WS)				
Tested Date	Jul. 10 ~ Jul. 12, 2018				
Instrument	Manufacturer	Model No.	Serial No.	Calibration Date	Calibration Until
Spectrum Analyzer	R&S	FSV40	101063	Apr. 16, 2018	Apr. 15, 2019
Power Meter	Anritsu	ML2495A	1241002	Oct. 16, 2017	Oct. 15, 2018
Power Sensor	Anritsu	MA2411B	1207366	Oct. 16, 2017	Oct. 15, 2018
AC POWER SOURCE	APC	AFC-500W	F312060012	Dec. 01, 2017	Nov. 30, 2018
Measurement Software	Sporton	Sporton_1	1.3.30	NA	NA
Note: Calibration Interval of instruments listed above is one year.					

1.4 Testing Applied Standards

According to the specification of EUT, the EUT must comply with following standards and KDB documents.

47 CFR FCC Part 15.407

ANSI C63.10-2013

FCC KDB 789033 D02 General UNII Test Procedures New Rules v02r01

FCC KDB 662911 D01 Multiple Transmitter Output v02r01

FCC KDB 412172 D01 Determining ERP and EIRP v01r01

1.5 Measurement Uncertainty

ISO/IEC 17025 requires that an estimate of the measurement uncertainties associated with the emissions test results be included in the report. The measurement uncertainties given below are based on a 95% confidence level (based on a coverage factor (k=2))

Measurement Uncertainty	
Parameters	Uncertainty
Bandwidth	±34.134 Hz
Conducted power	±0.808 dB
Frequency error	±34.134 Hz
Power density	±0.463 dB
Conducted emission	±2.670 dB
AC conducted emission	±2.90 dB
Radiated emission ≤ 1GHz	±3.66 dB
Radiated emission > 1GHz	±5.63 dB
Time	±0.1%
Temperature	±0.6 °C

2 Test Configuration

2.1 Testing Condition

Test Item	Test Site	Ambient Condition	Tested By
AC Conduction	CO01-WS	24°C / 57%	Alex Tsai
Radiated Emissions	03CH01-WS	24-25°C /60-63%	Akun Chung Roger Lu
RF Conducted	TH01-WS	23°C / 63%	Brad Wu

- FCC Designation No.: TW2732
- FCC site registration No.: 181692
- IC site registration No.: 10807A-1

2.2 The Worst Test Modes and Channel Details

Frequency band 5150~5250 MHz / 5250~5350 MHz / 5470~5725 MHz				
Test item	Modulation Mode	Test Frequency (MHz)	Data Rate (Mbps) / MCS	Test Configuration
Conducted Emissions	VHT20	5240	MCS 0	2
Radiated Emissions ≤1GHz	VHT20	5240	MCS 0	1, 2, 3, 4
Radiated Emissions >1GHz	11a	5180 / 5200 / 5240 / 5260 / 5300 5320 / 5500 / 5580 / 5700 / 5720	6 Mbps	1, 2, 3, 4
	VHT20	5180 / 5200 / 5240 / 5260 / 5300 5320 / 5500 / 5580 / 5700 / 5720	MCS 0	
	VHT40	5190 / 5230 / 5270 / 5310 / 5510 5590 / 5670 / 5710	MCS 0	
	VHT80	5210 / 5290 / 5530 / 5610 / 5690	MCS 0	
RF Output Power	11a	5180 / 5200 / 5240 / 5260 / 5300 5320 / 5500 / 5580 / 5700 / 5720	6 Mbps	2
	HT20	5180 / 5200 / 5240 / 5260 / 5300 5320 / 5500 / 5580 / 5700 / 5720	MCS 0	
	HT40	5190 / 5230 / 5270 / 5310 / 5510 5590 / 5670 / 5710	MCS 0	
	VHT20	5180 / 5200 / 5240 / 5260 / 5300 5320 / 5500 / 5580 / 5700 / 5720	MCS 0	
	VHT40	5190 / 5230 / 5270 / 5310 / 5510 5590 / 5670 / 5710	MCS 0	
	VHT80	5210 / 5290 / 5530 / 5610 / 5690	MCS 0	
Emission Bandwidth Peak Power Spectral Density	11a	5180 / 5200 / 5240 / 5260 / 5300 5320 / 5500 / 5580 / 5700 / 5720	6 Mbps	2
	VHT20	5180 / 5200 / 5240 / 5260 / 5300 5320 / 5500 / 5580 / 5700 / 5720	MCS 0	
	VHT40	5190 / 5230 / 5270 / 5310 / 5510 5590 / 5670 / 5710	MCS 0	
	VHT80	5210 / 5290 / 5530 / 5610 / 5690	MCS 0	
Frequency Stability	Un-modulation	5320	---	2

NOTE:

1. The EUT was pretested with 3 orientations placed on the table for the radiated emission measurement – X, Y, and Z-plane. The **X-plane** results were found as the worst case and were shown in this report.
2. 4 types antenna are used for this device, highest gain antenna of each type is selected to perform test as below test configuration.

Configuration 1 : Dipole antenna with 2 dBi gain

Configuration 2 : PCB Dipole antenna with 3.9 dBi (5.15~5.35GHz) / 4dBi gain (5.47~5.725GHz)

Configuration 3 : PIFA antenna with 3dBi gain

Configuration 4 : Magnetic Dipole with 3.5dBi gain

Frequency band 5725-5850 MHz				
Test item	Modulation Mode	Test Frequency (MHz)	Data Rate (Mbps) / MCS	Test Configuration
Conducted Emissions	VHT20	5745	MCS 0	2
Radiated Emissions ≤1GHz	VHT20	5745	MCS 0	1, 2, 3, 4
Radiated Emissions >1GHz	11a	5745 / 5785 / 5825	6 Mbps	1, 2, 3, 4
	VHT20	5745 / 5785 / 5825	MCS 0	
	VHT40	5755 / 5795	MCS 0	
	VHT80	5775	MCS 0	
RF Output Power	11a	5745 / 5785 / 5825	6 Mbps	2
	HT20	5745 / 5785 / 5825	MCS 0	
	HT40	5755 / 5795	MCS 0	
	VHT20	5745 / 5785 / 5825	MCS 0	
	VHT40	5755 / 5795	MCS 0	
	VHT80	5775	MCS 0	
Radiated Emissions >1GHz Emission Bandwidth 6dB bandwidth Peak Power Spectral Density	11a	5745 / 5785 / 5825	6 Mbps	2
	VHT20	5745 / 5785 / 5825	MCS 0	
	VHT40	5755 / 5795	MCS 0	
	VHT80	5775	MCS 0	
Frequency Stability	Un-modulation	5785	---	2

NOTE:

- The EUT was pretested with 3 orientations placed on the table for the radiated emission measurement – X, Y, and Z-plane. The **X-plane** results were found as the worst case and were shown in this report.
- 4 types antenna are used for this device, highest gain antenna of each type is selected to perform test as below test configuration.
 Configuration 1 : Dipole antenna with 2 dBi gain
 Configuration 2 : PCB Dipole antenna with 4dBi gain
 Configuration 3 : PIFA antenna with 3dBi gain
 Configuration 4 : Magnetic Dipole with 3.5dBi gain

3 Transmitter Test Results

3.1 Conducted Emissions

3.1.1 Limit of Conducted Emissions

Conducted Emissions Limit		
Frequency Emission (MHz)	Quasi-Peak	Average
0.15-0.5	66 - 56 *	56 - 46 *
0.5-5	56	46
5-30	60	50

Note 1: * Decreases with the logarithm of the frequency.

3.1.2 Test Procedures

1. The device is placed on a test table, raised 80 cm above the reference ground plane. The vertical conducting plane is located 40 cm to the rear of the device.
2. The device is connected to line impedance stabilization network (LISN) and other accessories are connected to other LISN. Measured levels of AC power line conducted emission are across the 50 Ω LISN port.
3. AC conducted emission measurements is made over frequency range from 150 kHz to 30 MHz.
4. This measurement was performed with AC 120V/60Hz

3.1.3 Test Setup

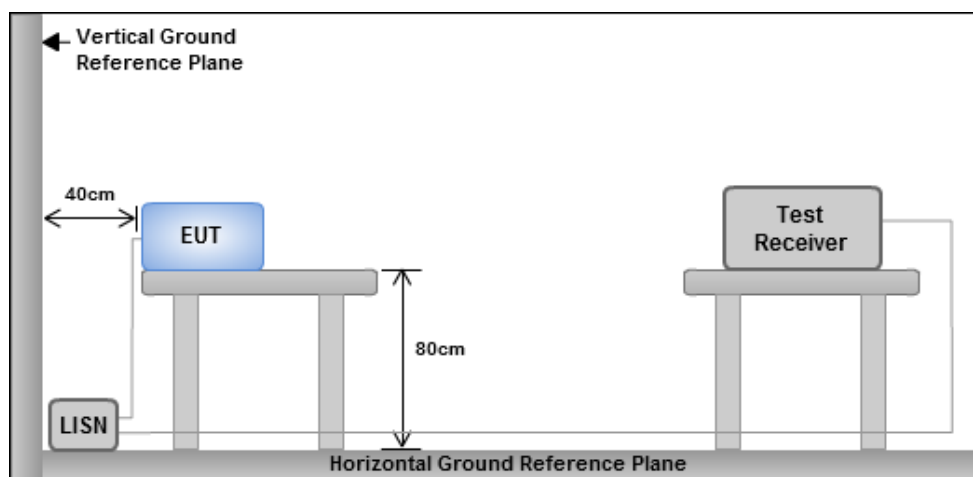

- Note: 1. Support units were connected to second LISN.
 2. Both of LISNs (AMN) are 80 cm from EUT and at least 80 cm from other units and other metal planes

3.1.4 Test Result of Conducted Emissions

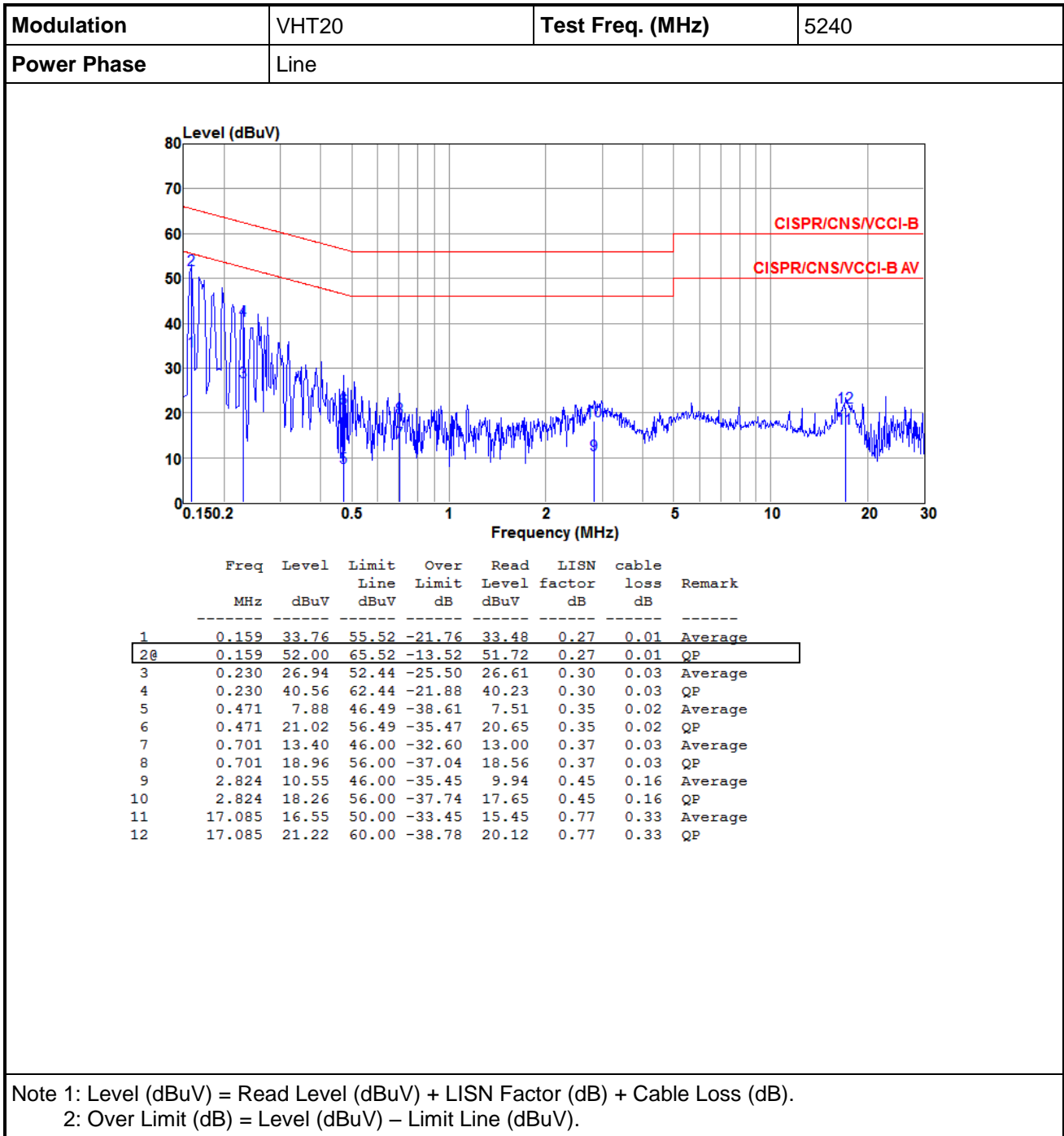

Modulation	VHT20	Test Freq. (MHz)	5240
Power Phase	Neutral		

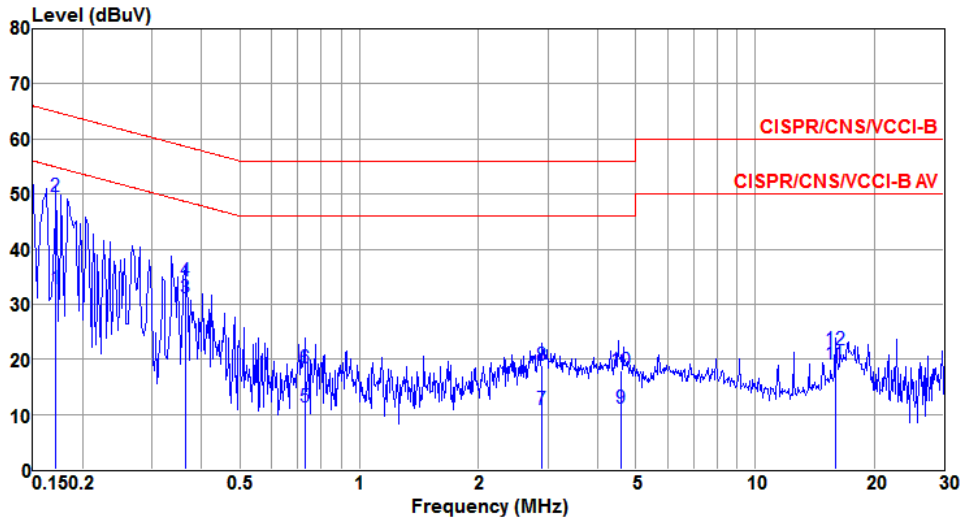

	Freq MHz	Level dBuV	Limit Line dBuV	Over Limit dB	Read Level dBuV	LISN factor dB	cable loss dB	Remark
1	0.171	32.79	54.90	-22.11	32.63	0.14	0.02	Average
2@	0.171	49.47	64.90	-15.43	49.31	0.14	0.02	QP
3	0.363	31.05	48.65	-17.60	30.85	0.18	0.02	Average
4	0.363	34.28	58.65	-24.37	34.08	0.18	0.02	QP
5	0.727	11.45	46.00	-34.55	11.18	0.24	0.03	Average
6	0.727	18.30	56.00	-37.70	18.03	0.24	0.03	QP
7	2.884	10.85	46.00	-35.15	10.36	0.33	0.16	Average
8	2.884	18.89	56.00	-37.11	18.40	0.33	0.16	QP
9	4.582	11.05	46.00	-34.95	10.45	0.37	0.23	Average
10	4.582	17.91	56.00	-38.09	17.31	0.37	0.23	QP
11	15.946	19.08	50.00	-30.92	18.16	0.60	0.32	Average
12	15.946	21.76	60.00	-38.24	20.84	0.60	0.32	QP

Note 1: Level (dBuV) = Read Level (dBuV) + LISN Factor (dB) + Cable Loss (dB).
 2: Over Limit (dB) = Level (dBuV) – Limit Line (dBuV).

Modulation	VHT20	Test Freq. (MHz)	5745
Power Phase	Line		

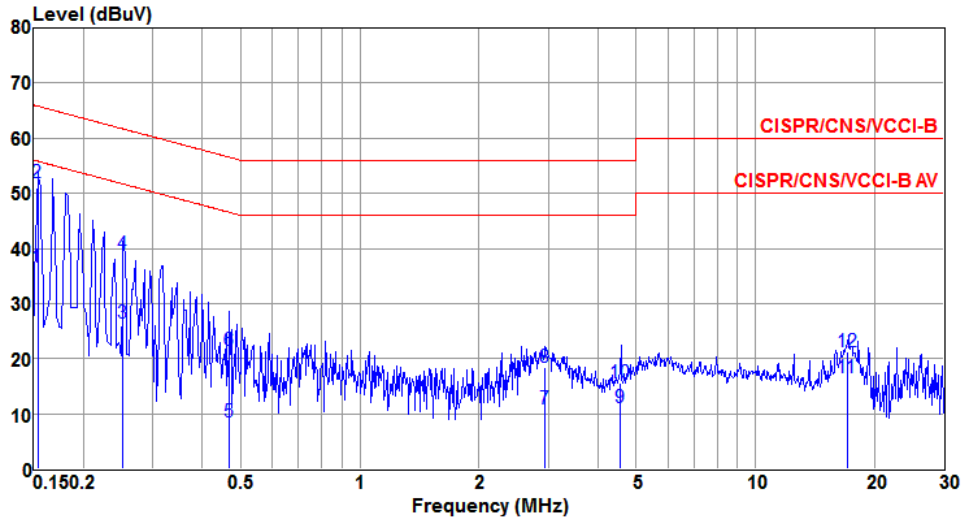

	Freq	Level	Limit	Over	Read	LISN	cable	Remark
	MHz	dBuV	Line	Limit	Level	factor	loss	
			dBuV	dB	dBuV	dB	dB	
1	0.153	36.48	55.82	-19.34	36.20	0.27	0.01	Average
2 ^①	0.153	52.04	65.82	-13.78	51.76	0.27	0.01	QP
3	0.252	26.49	51.69	-25.20	26.15	0.31	0.03	Average
4	0.252	39.01	61.69	-22.68	38.67	0.31	0.03	QP
5	0.469	8.57	46.54	-37.97	8.20	0.35	0.02	Average
6	0.469	21.43	56.54	-35.11	21.06	0.35	0.02	QP
7	2.946	10.79	46.00	-35.21	10.17	0.45	0.17	Average
8	2.946	18.31	56.00	-37.69	17.69	0.45	0.17	QP
9	4.553	11.09	46.00	-34.91	10.38	0.48	0.23	Average
10	4.553	15.66	56.00	-40.34	14.95	0.48	0.23	QP
11	17.086	16.53	50.00	-33.47	15.43	0.77	0.33	Average
12	17.086	21.21	60.00	-38.79	20.11	0.77	0.33	QP

Note 1: Level (dBuV) = Read Level (dBuV) + LISN Factor (dB) + Cable Loss (dB).
 Note 2: Over Limit (dB) = Level (dBuV) – Limit Line (dBuV).

Modulation	VHT20	Test Freq. (MHz)	5745
Power Phase	Neutral		

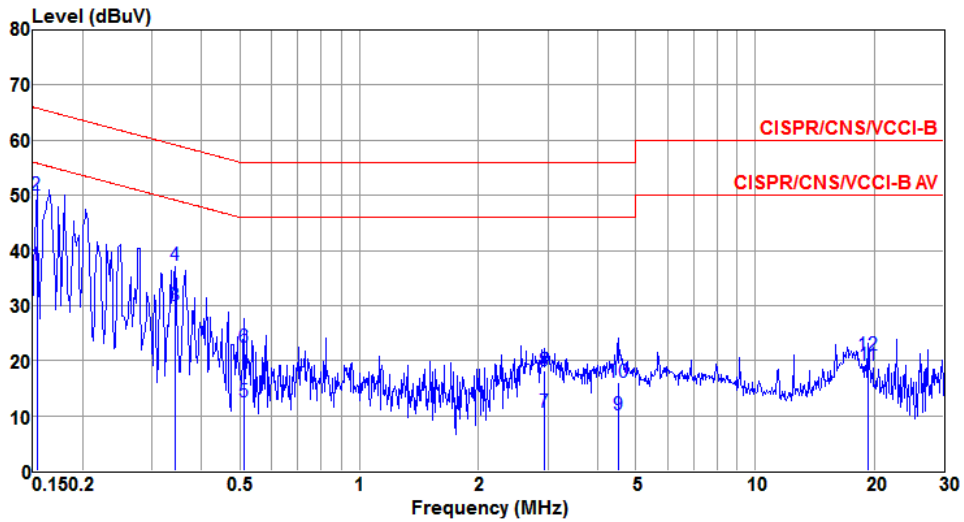

	Freq	Level	Limit	Over	Read	LISN	cable	Remark
	MHz	dBuV	Line	Limit	Level	factor	loss	
			dBuV	dB	dBuV	dB	dB	
1	0.153	37.35	55.82	-18.47	37.20	0.14	0.01	Average
2 ²	0.153	49.99	65.82	-15.83	49.84	0.14	0.01	QP
3	0.343	29.88	49.13	-19.25	29.68	0.18	0.02	Average
4	0.343	37.30	59.13	-21.83	37.10	0.18	0.02	QP
5	0.510	12.58	46.00	-33.42	12.35	0.21	0.02	Average
6	0.510	22.37	56.00	-33.63	22.14	0.21	0.02	QP
7	2.931	10.56	46.00	-35.44	10.06	0.33	0.17	Average
8	2.931	18.10	56.00	-37.90	17.60	0.33	0.17	QP
9	4.501	10.20	46.00	-35.80	9.61	0.36	0.23	Average
10	4.501	15.94	56.00	-40.06	15.35	0.36	0.23	QP
11	19.364	19.17	50.00	-30.83	18.10	0.73	0.34	Average
12	19.364	21.11	60.00	-38.89	20.04	0.73	0.34	QP

Note 1: Level (dBuV) = Read Level (dBuV) + LISN Factor (dB) + Cable Loss (dB).
 Note 2: Over Limit (dB) = Level (dBuV) – Limit Line (dBuV).

3.2 Emission Bandwidth

3.2.1 Limit of Emission Bandwidth

Within the 5.725-5.85 GHz band, the minimum 6 dB bandwidth of U-NII devices shall be at least 500 kHz.

3.2.2 Test Procedures

26dB Bandwidth

1. Set RBW = approximately 1% of the emission bandwidth.
2. Set the VBW > RBW, Detector = Peak.
3. Trace mode = max hold.
4. Measure the maximum width of the emission that is 26 dB down from the peak of the emission.

Occupied Bandwidth

1. Set RBW = 1 % to 5 % of the OBW.
2. Set VBW \geq 3 RBW.
3. Sample detection and single sweep mode shall be used.
4. Use the 99 % power bandwidth function of the instrument.

6dB Bandwidth

1. Set RBW = 100kHz, VBW = 300kHz.
2. Detector = Peak, Trace mode = max hold.
3. Allow the trace to stabilize.
4. Measure the maximum width of the emission that is constrained by the frequencies associated with the two outermost amplitude points (upper and lower frequencies) that are attenuated by 6 dB relative to the maximum level measured in the fundamental emission.

3.2.3 Test Setup

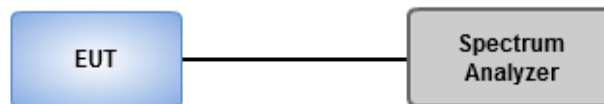

3.2.4 Test Result of Emission Bandwidth

Summary

Mode	Max-N dB (Hz)	Max-OBW (Hz)	ITU-Code	Min-N dB (Hz)	Min-OBW (Hz)
5.15-5.25GHz	-	-	-	-	-
802.11a_Nss1,(6Mbps)_2TX	28.333M	16.787M	16M8D1D	19.638M	16.643M
802.11ac VHT20_Nss1,(MCS0)_2TX	20.58M	17.656M	17M7D1D	19.855M	17.656M
802.11ac VHT40_Nss1,(MCS0)_2TX	40.145M	36.324M	36M3D1D	39.71M	36.179M
802.11ac VHT80_Nss1,(MCS0)_2TX	82.029M	75.832M	75M8D1D	81.449M	75.832M
5.25-5.35GHz	-	-	-	-	-
802.11a_Nss1,(6Mbps)_2TX	19.783M	16.643M	16M6D1D	19.493M	16.57M
802.11ac VHT20_Nss1,(MCS0)_2TX	20.29M	17.656M	17M7D1D	19.71M	17.583M
802.11ac VHT40_Nss1,(MCS0)_2TX	40.435M	36.179M	36M2D1D	39.71M	36.179M
802.11ac VHT80_Nss1,(MCS0)_2TX	81.739M	76.122M	76M1D1D	81.449M	75.832M
5.47-5.725GHz	-	-	-	-	-
802.11a_Nss1,(6Mbps)_2TX	31.232M	16.86M	16M9D1D	19.348M	13.415M
802.11ac VHT20_Nss1,(MCS0)_2TX	20.435M	17.728M	17M7D1D	14.957M	13.849M
802.11ac VHT40_Nss1,(MCS0)_2TX	40.58M	36.179M	36M2D1D	34.899M	33.025M
802.11ac VHT80_Nss1,(MCS0)_2TX	81.739M	76.122M	76M1D1D	75.435M	72.721M
5.725-5.85GHz	-	-	-	-	-
802.11a_Nss1,(6Mbps)_2TX	16.594M	16.86M	16M9D1D	3.246M	4.631M
802.11ac VHT20_Nss1,(MCS0)_2TX	17.754M	17.8M	17M8D1D	3.826M	4.052M
802.11ac VHT40_Nss1,(MCS0)_2TX	36.522M	36.179M	36M2D1D	3.13M	3.531M
802.11ac VHT80_Nss1,(MCS0)_2TX	76.522M	76.122M	76M1D1D	3.246M	7.062M

Max-N dB = Maximum 6dB down bandwidth for 5.725-5.85GHz band / Maximum 26dB down bandwidth for other band;

Max-OBW = Maximum 99% occupied bandwidth;

Min-N dB = Minimum 6dB down bandwidth for 5.725-5.85GHz band / Maximum 26dB down bandwidth for other band;

Min-OBW = Minimum 99% occupied bandwidth;

Result

Mode	Result	Limit (Hz)	Port 1-N dB (Hz)	Port 1-OBW (Hz)	Port 2-N dB (Hz)	Port 2-OBW (Hz)
802.11a_Nss1,(6Mbps)_2TX	-	-	-	-	-	-
5180MHz	Pass	Inf	19.638M	16.643M	19.638M	16.715M
5200MHz	Pass	Inf	22.971M	16.715M	27.681M	16.787M
5240MHz	Pass	Inf	24.855M	16.715M	28.333M	16.787M
5260MHz	Pass	Inf	19.638M	16.643M	19.565M	16.643M
5300MHz	Pass	Inf	19.783M	16.643M	19.565M	16.643M
5320MHz	Pass	Inf	19.565M	16.57M	19.493M	16.57M
5500MHz	Pass	Inf	19.638M	16.643M	19.71M	16.715M
5580MHz	Pass	Inf	26.594M	16.715M	31.232M	16.86M
5700MHz	Pass	Inf	19.565M	16.57M	19.71M	16.57M
5720MHz Straddle 5.47-5.725GHz	Pass	Inf	19.348M	13.415M	19.565M	13.415M
5720MHz Straddle 5.725-5.85GHz	Pass	500k	3.246M	4.631M	3.246M	4.978M
5745MHz	Pass	500k	16.594M	16.787M	16.594M	16.787M
5785MHz	Pass	500k	16.522M	16.787M	16.522M	16.86M
5825MHz	Pass	500k	16.594M	16.715M	16.594M	16.86M
802.11ac VHT20_Nss1,(MCS0)_2TX	-	-	-	-	-	-
5180MHz	Pass	Inf	19.855M	17.656M	20.145M	17.656M
5200MHz	Pass	Inf	20.145M	17.656M	20.58M	17.656M
5240MHz	Pass	Inf	20M	17.656M	20.507M	17.656M
5260MHz	Pass	Inf	20M	17.656M	20M	17.656M
5300MHz	Pass	Inf	19.928M	17.583M	20.29M	17.656M
5320MHz	Pass	Inf	19.71M	17.656M	20M	17.656M
5500MHz	Pass	Inf	19.928M	17.656M	20.362M	17.656M
5580MHz	Pass	Inf	20.362M	17.656M	20.435M	17.728M
5700MHz	Pass	Inf	19.928M	17.656M	19.928M	17.656M
5720MHz Straddle 5.47-5.725GHz	Pass	Inf	15.217M	13.849M	14.957M	13.849M
5720MHz Straddle 5.725-5.85GHz	Pass	500k	3.826M	4.052M	3.884M	4.11M
5745MHz	Pass	500k	17.681M	17.656M	17.754M	17.728M
5785MHz	Pass	500k	17.681M	17.656M	17.754M	17.8M
5825MHz	Pass	500k	17.681M	17.656M	17.681M	17.728M
802.11ac VHT40_Nss1,(MCS0)_2TX	-	-	-	-	-	-
5190MHz	Pass	Inf	39.71M	36.324M	39.855M	36.179M
5230MHz	Pass	Inf	39.71M	36.179M	40.145M	36.179M
5270MHz	Pass	Inf	39.71M	36.179M	40.435M	36.179M
5310MHz	Pass	Inf	40.145M	36.179M	40.435M	36.179M
5510MHz	Pass	Inf	40.145M	36.179M	40.58M	36.179M
5590MHz	Pass	Inf	39.855M	36.179M	40.145M	36.179M
5670MHz	Pass	Inf	39.71M	36.035M	40.29M	36.179M

Mode	Result	Limit (Hz)	Port 1-N dB (Hz)	Port 1-OBW (Hz)	Port 2-N dB (Hz)	Port 2-OBW (Hz)
5710MHz Straddle 5.47-5.725GHz	Pass	Inf	34.899M	33.025M	35M	33.025M
5710MHz Straddle 5.725-5.85GHz	Pass	500k	3.13M	3.531M	3.188M	3.647M
5755MHz	Pass	500k	36.377M	36.179M	36.522M	36.179M
5795MHz	Pass	500k	36.377M	36.179M	36.522M	36.179M
802.11ac VHT80_Nss1,(MCS0)_2TX	-	-	-	-	-	-
5210MHz	Pass	Inf	81.449M	75.832M	82.029M	75.832M
5290MHz	Pass	Inf	81.449M	76.122M	81.739M	75.832M
5530MHz	Pass	Inf	81.449M	76.122M	81.739M	75.832M
5610MHz	Pass	Inf	81.449M	76.122M	81.739M	75.832M
5690MHz Straddle 5.47-5.725GHz	Pass	Inf	75.435M	72.721M	75.652M	72.721M
5690MHz Straddle 5.725-5.85GHz	Pass	500k	3.246M	10.825M	3.246M	7.062M
5775MHz	Pass	500k	76.522M	76.122M	76.522M	75.832M

Port X-N dB = Port X 6dB down bandwidth for 5.725-5.85GHz band / 26dB down bandwidth for other band

Port X-OBW = Port X 99% occupied bandwidth;

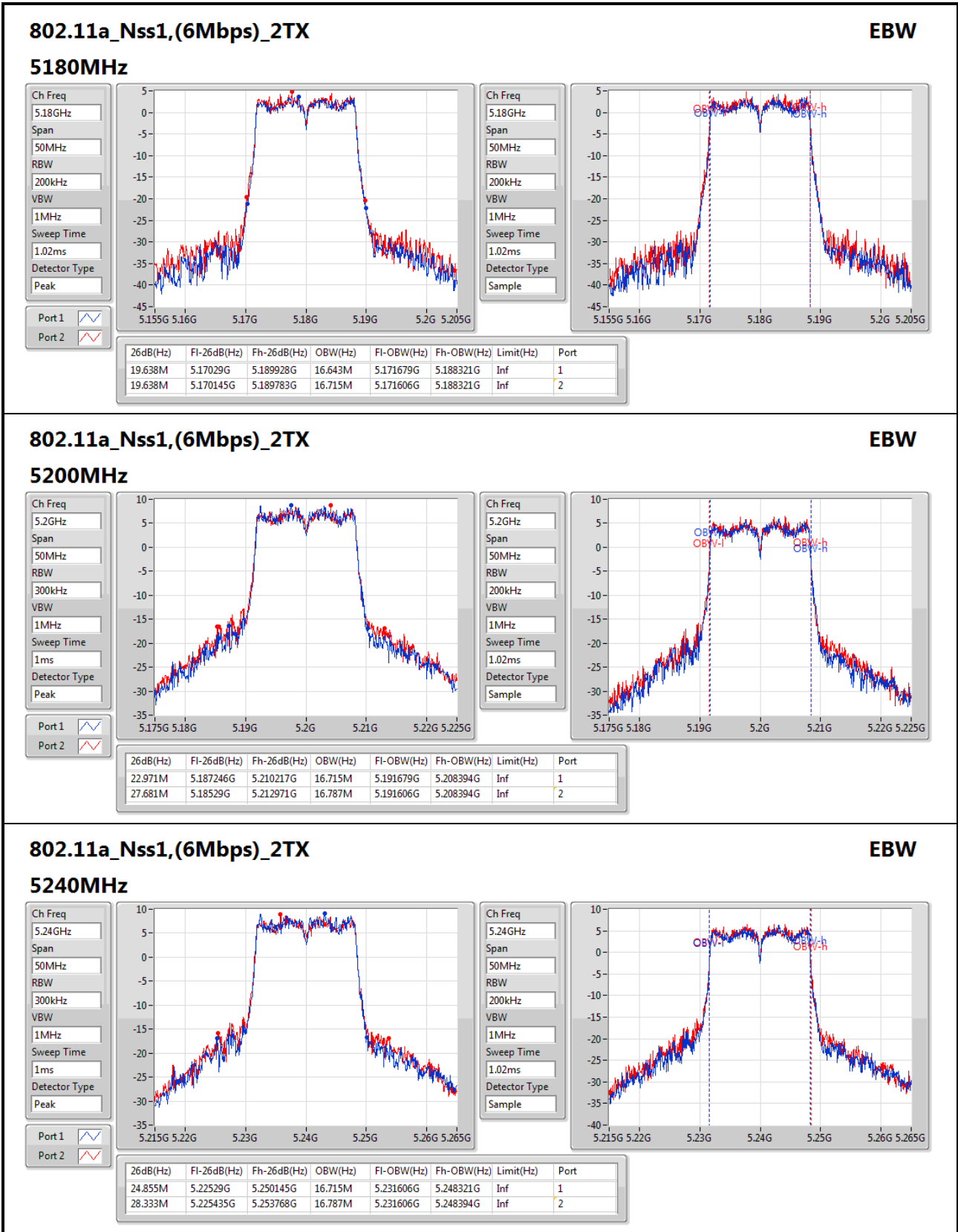

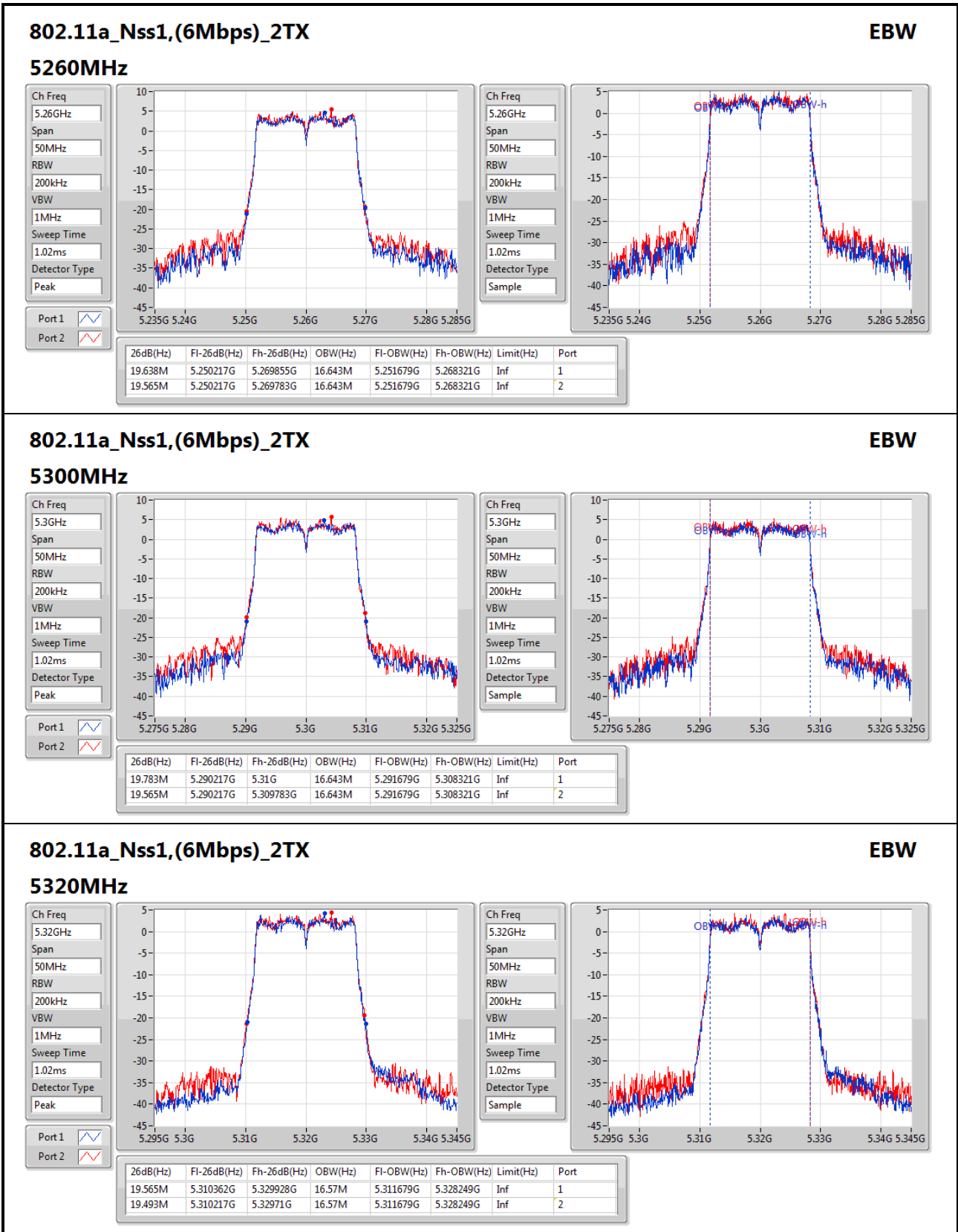

802.11a_Nss1,(6Mbps)_2TX

EBW

5500MHz

Ch Freq
5.5GHz

Span
50MHz

RBW
200kHz

VBW
1MHz

Sweep Time
1.02ms

Detector Type
Peak

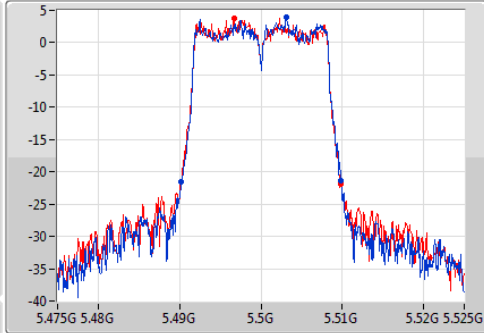

Ch Freq
5.5GHz

Span
50MHz

RBW
200kHz

VBW
1MHz

Sweep Time
1.02ms

Detector Type
Sample

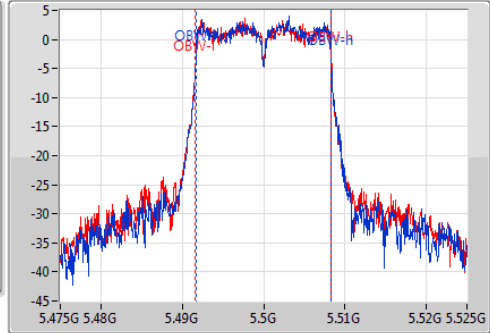

26dB(Hz)	Fl-26dB(Hz)	Fh-26dB(Hz)	OBW(Hz)	Fl-OBW(Hz)	Fh-OBW(Hz)	Limit(Hz)	Port
19.638M	5.490217G	5.509855G	16.643M	5.491679G	5.508321G	Inf	1
19.71M	5.490145G	5.509855G	16.715M	5.491606G	5.508321G	Inf	2

802.11a_Nss1,(6Mbps)_2TX

EBW

5580MHz

Ch Freq
5.58GHz

Span
50MHz

RBW
300kHz

VBW
1MHz

Sweep Time
1ms

Detector Type
Peak

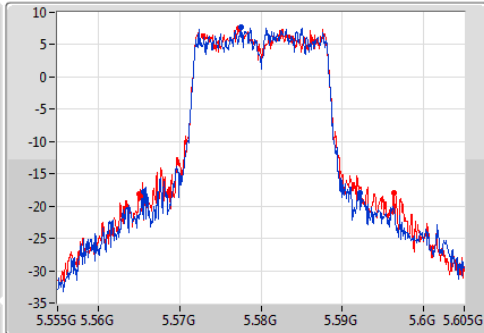

Ch Freq
5.58GHz

Span
50MHz

RBW
200kHz

VBW
1MHz

Sweep Time
1.02ms

Detector Type
Sample

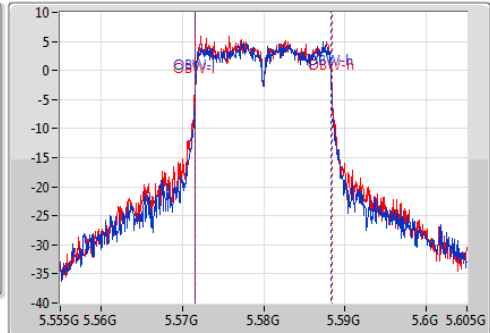

26dB(Hz)	Fl-26dB(Hz)	Fh-26dB(Hz)	OBW(Hz)	Fl-OBW(Hz)	Fh-OBW(Hz)	Limit(Hz)	Port
26.594M	5.56558G	5.592174G	16.715M	5.571606G	5.588321G	Inf	1
31.232M	5.565072G	5.596304G	16.86M	5.571534G	5.588394G	Inf	2

802.11a_Nss1,(6Mbps)_2TX

EBW

5700MHz

Ch Freq
5.7GHz

Span
50MHz

RBW
200kHz

VBW
1MHz

Sweep Time
1.02ms

Detector Type
Peak

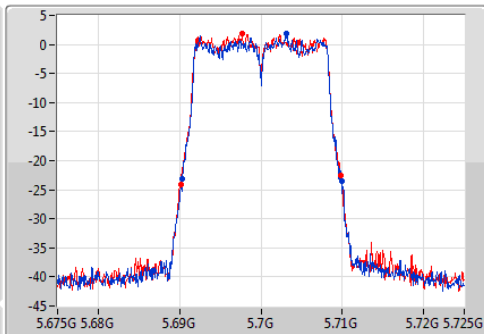

Ch Freq
5.7GHz

Span
50MHz

RBW
200kHz

VBW
1MHz

Sweep Time
1.02ms

Detector Type
Sample

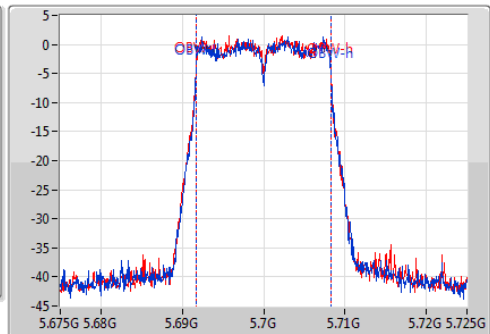

26dB(Hz)	Fl-26dB(Hz)	Fh-26dB(Hz)	OBW(Hz)	Fl-OBW(Hz)	Fh-OBW(Hz)	Limit(Hz)	Port
19.565M	5.690362G	5.709928G	16.57M	5.691679G	5.708249G	Inf	1
19.71M	5.690145G	5.709855G	16.57M	5.691679G	5.708249G	Inf	2

802.11a_Nss1,(6Mbps)_2TX

EBW

5720MHz Straddle 5.47-5.725GHz

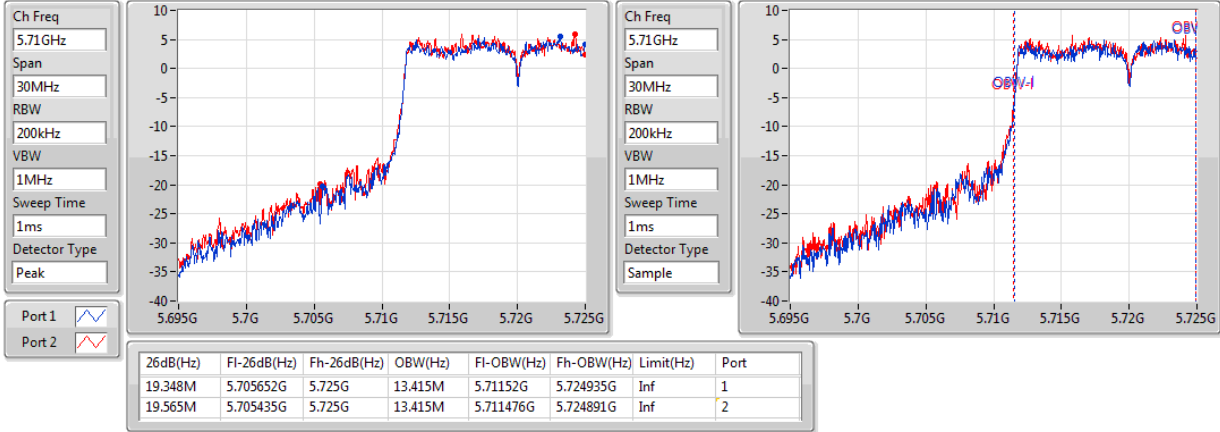

802.11a_Nss1,(6Mbps)_2TX

EBW

5720MHz Straddle 5.725-5.85GHz

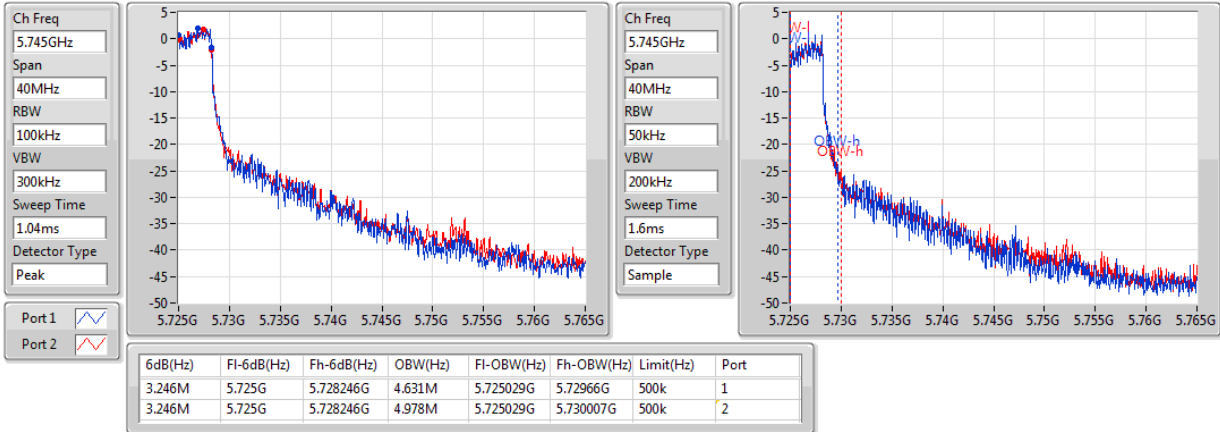

802.11a_Nss1,(6Mbps)_2TX

EBW

5745MHz

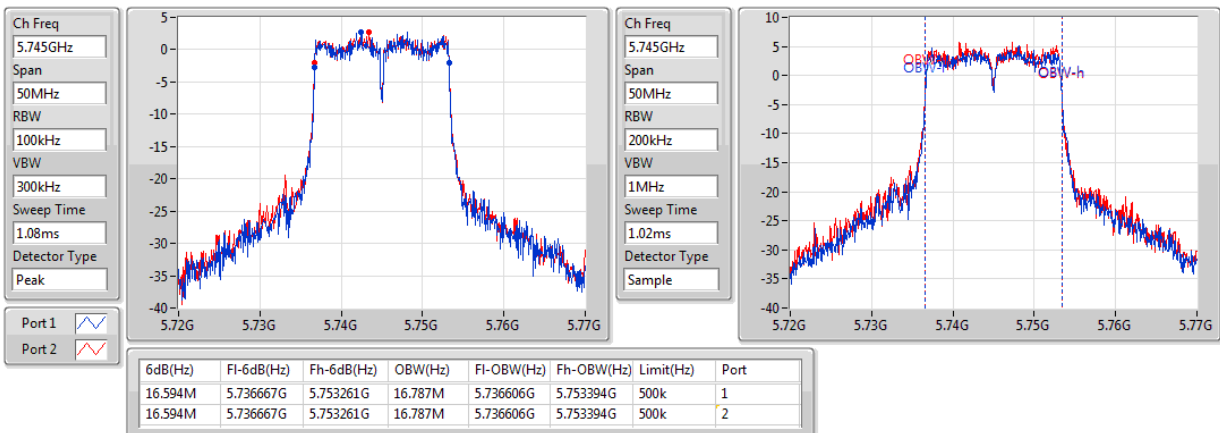

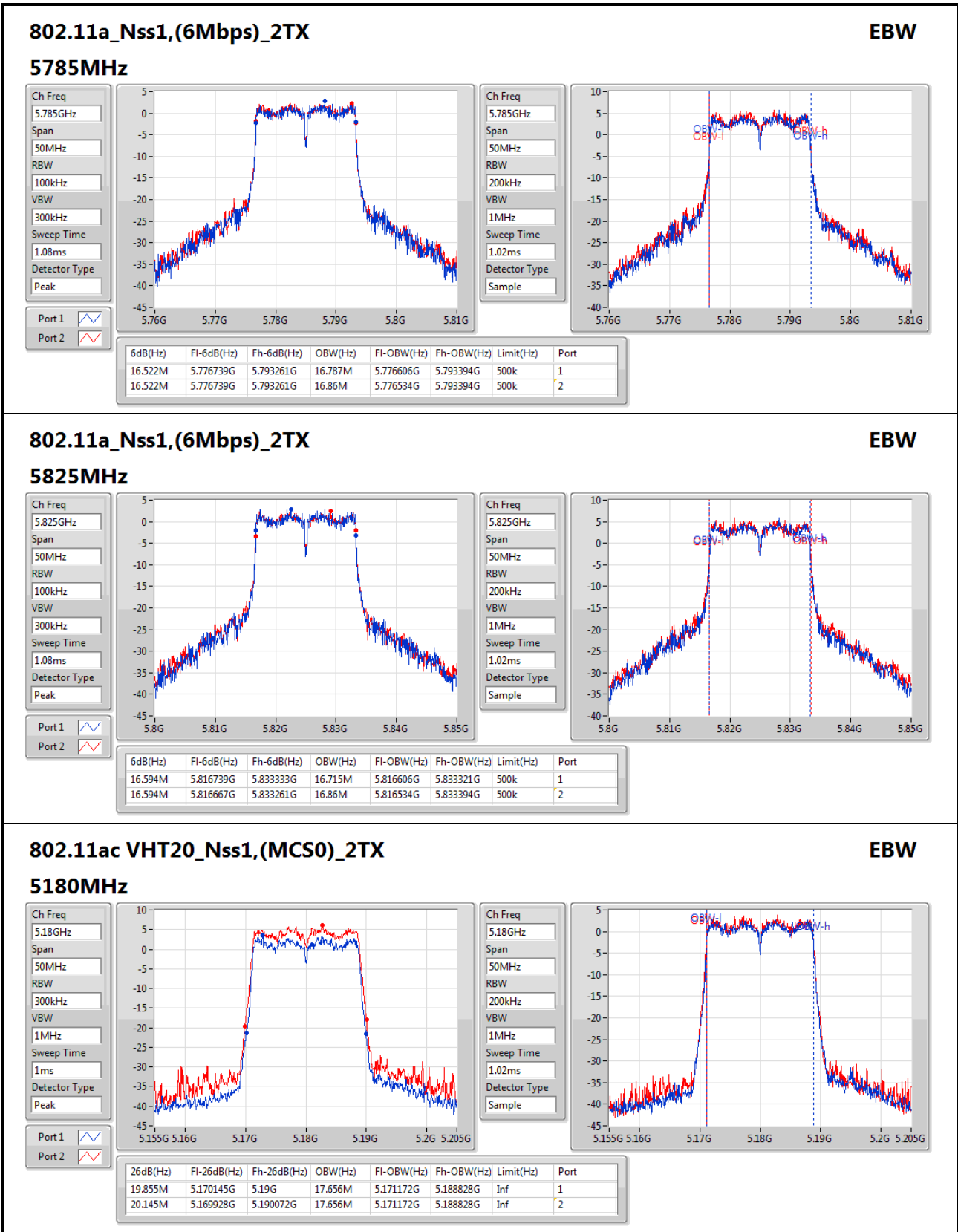
802.11ac VHT20_Nss1,(MCS0)_2TX
EBW
5180MHz

Ch Freq: 5.18GHz
Span: 50MHz
RBW: 300kHz
VBW: 1MHz
Sweep Time: 1ms
Detector Type: Peak



Ch Freq: 5.18GHz
Span: 50MHz
RBW: 200kHz
VBW: 1MHz
Sweep Time: 1.02ms
Detector Type: Sample



802.11ac VHT20_Nss1,(MCS0)_2TX

EBW

5200MHz

Ch Freq
5.2GHz
Span
50MHz
RBW
300kHz
VBW
1MHz
Sweep Time
1ms
Detector Type
Peak

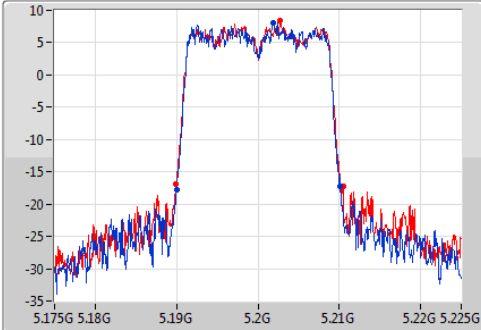

Ch Freq
5.2GHz
Span
50MHz
RBW
200kHz
VBW
1MHz
Sweep Time
1.02ms
Detector Type
Sample

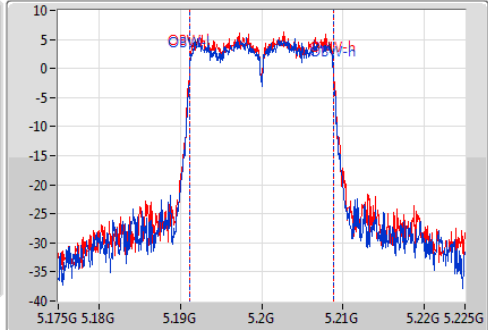

Port1
Port2

26dB(Hz)	Fl-26dB(Hz)	Fh-26dB(Hz)	OBW(Hz)	Fl-OBW(Hz)	Fh-OBW(Hz)	Limit(Hz)	Port
20.145M	5.19G	5.210145G	17.656M	5.191172G	5.208828G	Inf	1
20.58M	5.189928G	5.210507G	17.656M	5.191172G	5.208828G	Inf	2

802.11ac VHT20_Nss1,(MCS0)_2TX

EBW

5240MHz

Ch Freq
5.24GHz
Span
50MHz
RBW
300kHz
VBW
1MHz
Sweep Time
1ms
Detector Type
Peak

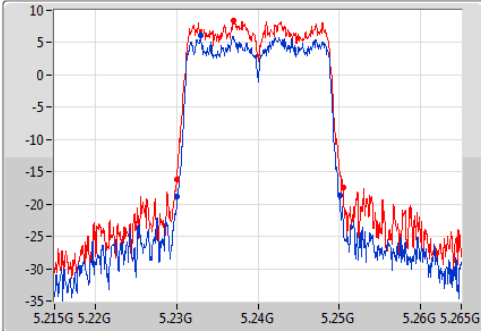

Ch Freq
5.24GHz
Span
50MHz
RBW
200kHz
VBW
1MHz
Sweep Time
1.02ms
Detector Type
Sample

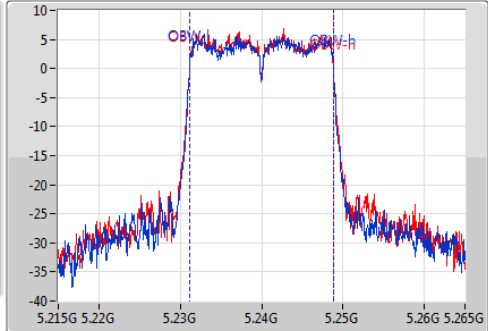

Port1
Port2

26dB(Hz)	Fl-26dB(Hz)	Fh-26dB(Hz)	OBW(Hz)	Fl-OBW(Hz)	Fh-OBW(Hz)	Limit(Hz)	Port
20M	5.230072G	5.250072G	17.656M	5.231172G	5.248828G	Inf	1
20.507M	5.23G	5.250507G	17.656M	5.231172G	5.248828G	Inf	2

802.11ac VHT20_Nss1,(MCS0)_2TX

EBW

5260MHz

Ch Freq
5.26GHz
Span
50MHz
RBW
200kHz
VBW
1MHz
Sweep Time
1.02ms
Detector Type
Peak

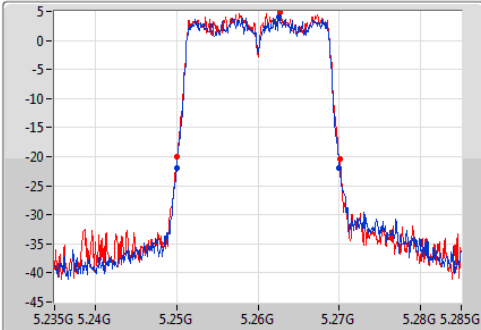

Ch Freq
5.26GHz
Span
50MHz
RBW
200kHz
VBW
1MHz
Sweep Time
1.02ms
Detector Type
Sample

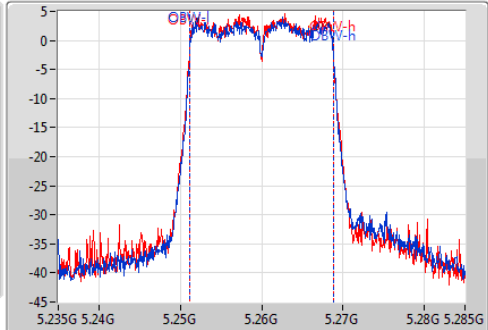

Port1
Port2

26dB(Hz)	Fl-26dB(Hz)	Fh-26dB(Hz)	OBW(Hz)	Fl-OBW(Hz)	Fh-OBW(Hz)	Limit(Hz)	Port
20M	5.25G	5.27G	17.656M	5.251172G	5.268828G	Inf	1
20M	5.250072G	5.270072G	17.656M	5.251172G	5.268828G	Inf	2

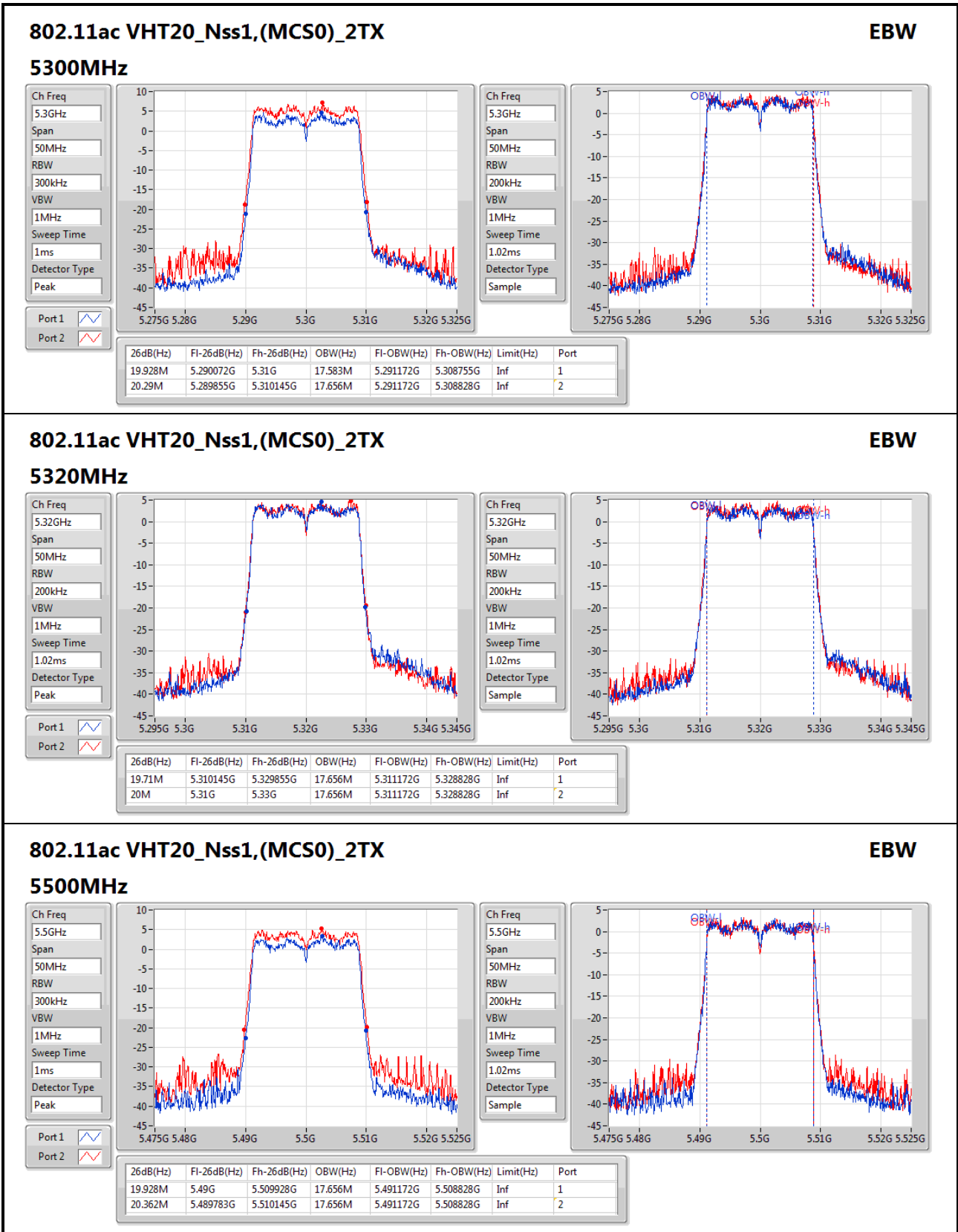
802.11ac VHT20_Nss1,(MCS0)_2TX
EBW
5500MHz

Ch Freq: 5.5GHz
Span: 50MHz
RBW: 300kHz
VBW: 1MHz
Sweep Time: 1ms
Detector Type: Peak



Ch Freq: 5.5GHz
Span: 50MHz
RBW: 200kHz
VBW: 1MHz
Sweep Time: 1.02ms
Detector Type: Sample



802.11ac VHT20_Nss1,(MCS0)_2TX

EBW

5580MHz

Ch Freq
5.58GHz
Span
50MHz
RBW
300kHz
VBW
1MHz
Sweep Time
1ms
Detector Type
Peak

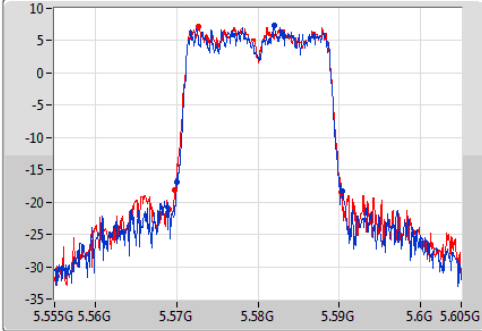

Ch Freq
5.58GHz
Span
50MHz
RBW
200kHz
VBW
1MHz
Sweep Time
1.02ms
Detector Type
Sample

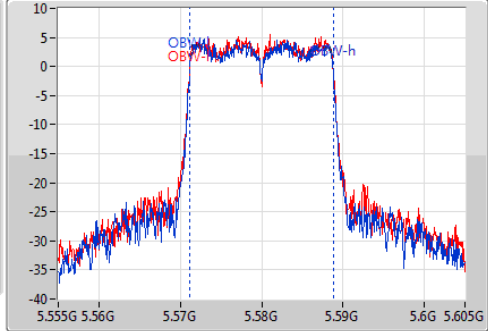

26dB(Hz)	Fl-26dB(Hz)	Fh-26dB(Hz)	OBW(Hz)	Fl-OBW(Hz)	Fh-OBW(Hz)	Limit(Hz)	Port
20.362M	5.57G	5.590362G	17.656M	5.571172G	5.588828G	Inf	1
20.435M	5.569783G	5.590217G	17.728M	5.5711G	5.588828G	Inf	2

802.11ac VHT20_Nss1,(MCS0)_2TX

EBW

5700MHz

Ch Freq
5.7GHz
Span
50MHz
RBW
200kHz
VBW
1MHz
Sweep Time
1.02ms
Detector Type
Peak

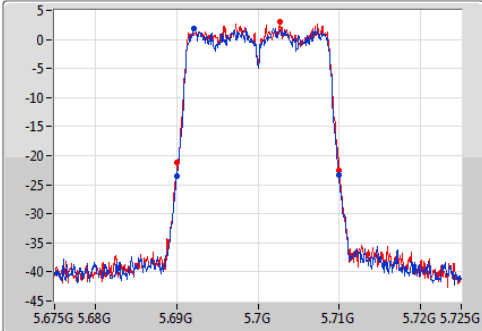

Ch Freq
5.7GHz
Span
50MHz
RBW
200kHz
VBW
1MHz
Sweep Time
1.02ms
Detector Type
Sample

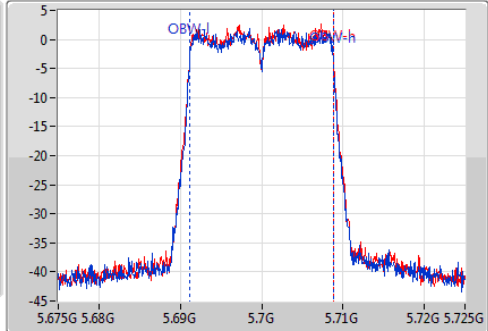

26dB(Hz)	Fl-26dB(Hz)	Fh-26dB(Hz)	OBW(Hz)	Fl-OBW(Hz)	Fh-OBW(Hz)	Limit(Hz)	Port
19.928M	5.69G	5.709928G	17.656M	5.691172G	5.708828G	Inf	1
19.928M	5.690072G	5.71G	17.656M	5.691172G	5.708828G	Inf	2

802.11ac VHT20_Nss1,(MCS0)_2TX

EBW

5720MHz Straddle 5.47-5.725GHz

Ch Freq
5.71GHz
Span
30MHz
RBW
200kHz
VBW
1MHz
Sweep Time
1ms
Detector Type
Peak

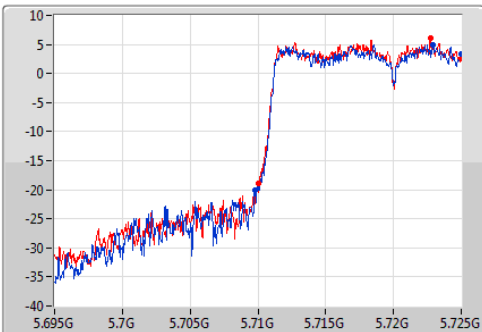

Ch Freq
5.71GHz
Span
30MHz
RBW
200kHz
VBW
1MHz
Sweep Time
1ms
Detector Type
Sample

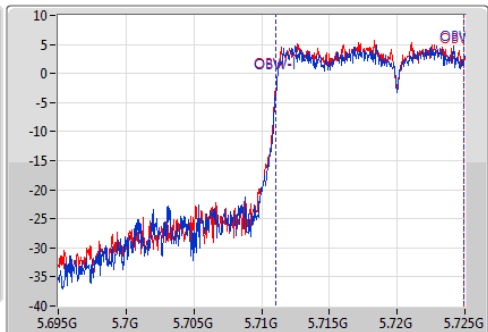

26dB(Hz)	Fl-26dB(Hz)	Fh-26dB(Hz)	OBW(Hz)	Fl-OBW(Hz)	Fh-OBW(Hz)	Limit(Hz)	Port
15.217M	5.709783G	5.725G	13.849M	5.711085G	5.724935G	Inf	1
14.957M	5.710043G	5.725G	13.849M	5.711085G	5.724935G	Inf	2

802.11ac VHT20_Nss1,(MCS0)_2TX

EBW

5720MHz Straddle 5.725-5.85GHz

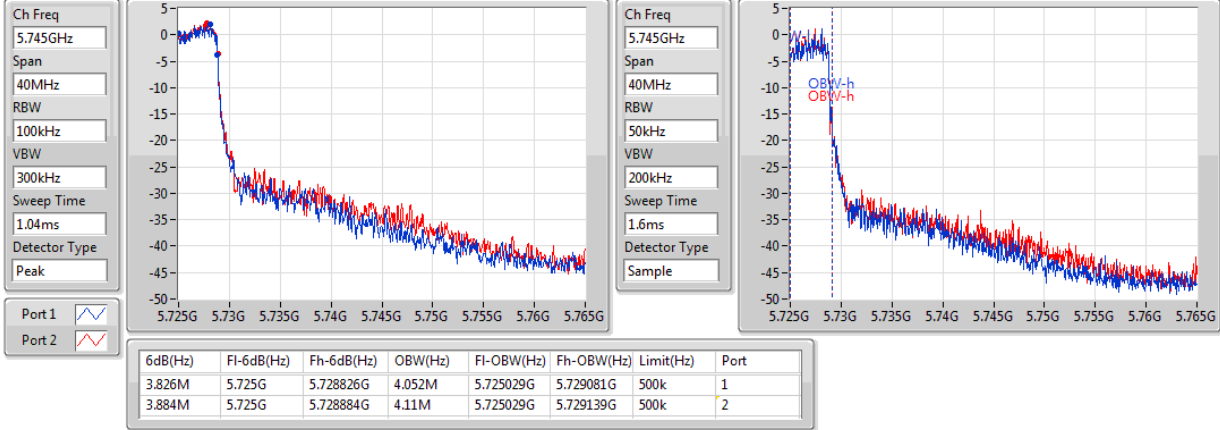

802.11ac VHT20_Nss1,(MCS0)_2TX

EBW

5745MHz

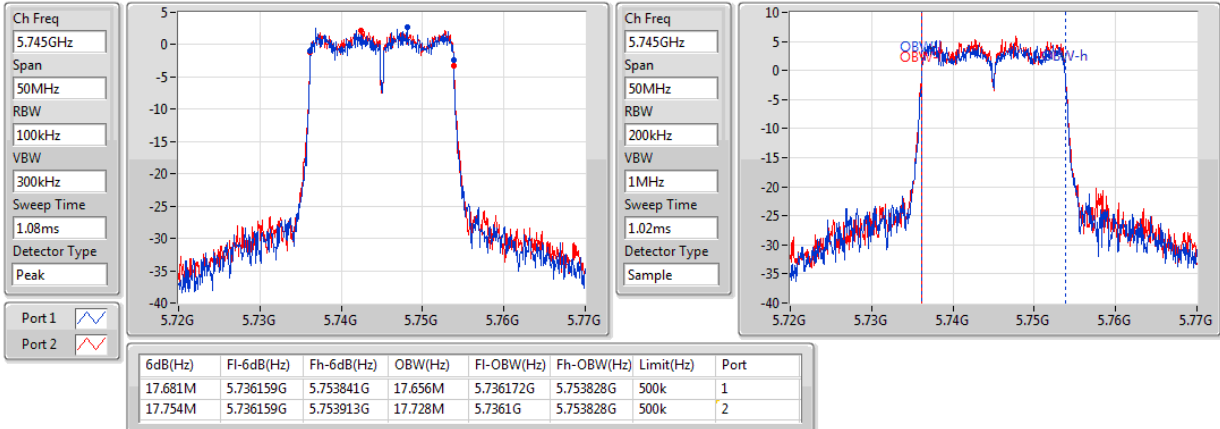

802.11ac VHT20_Nss1,(MCS0)_2TX

EBW

5785MHz

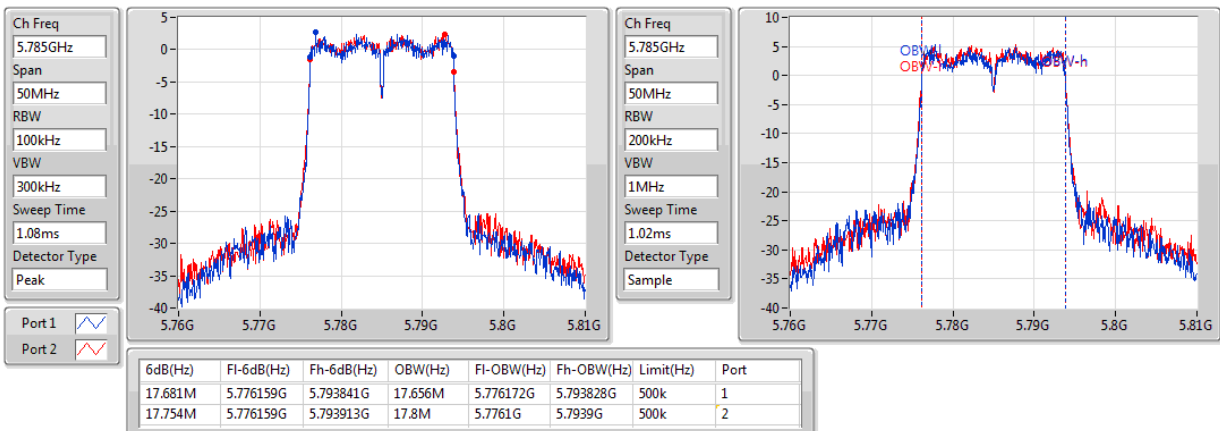

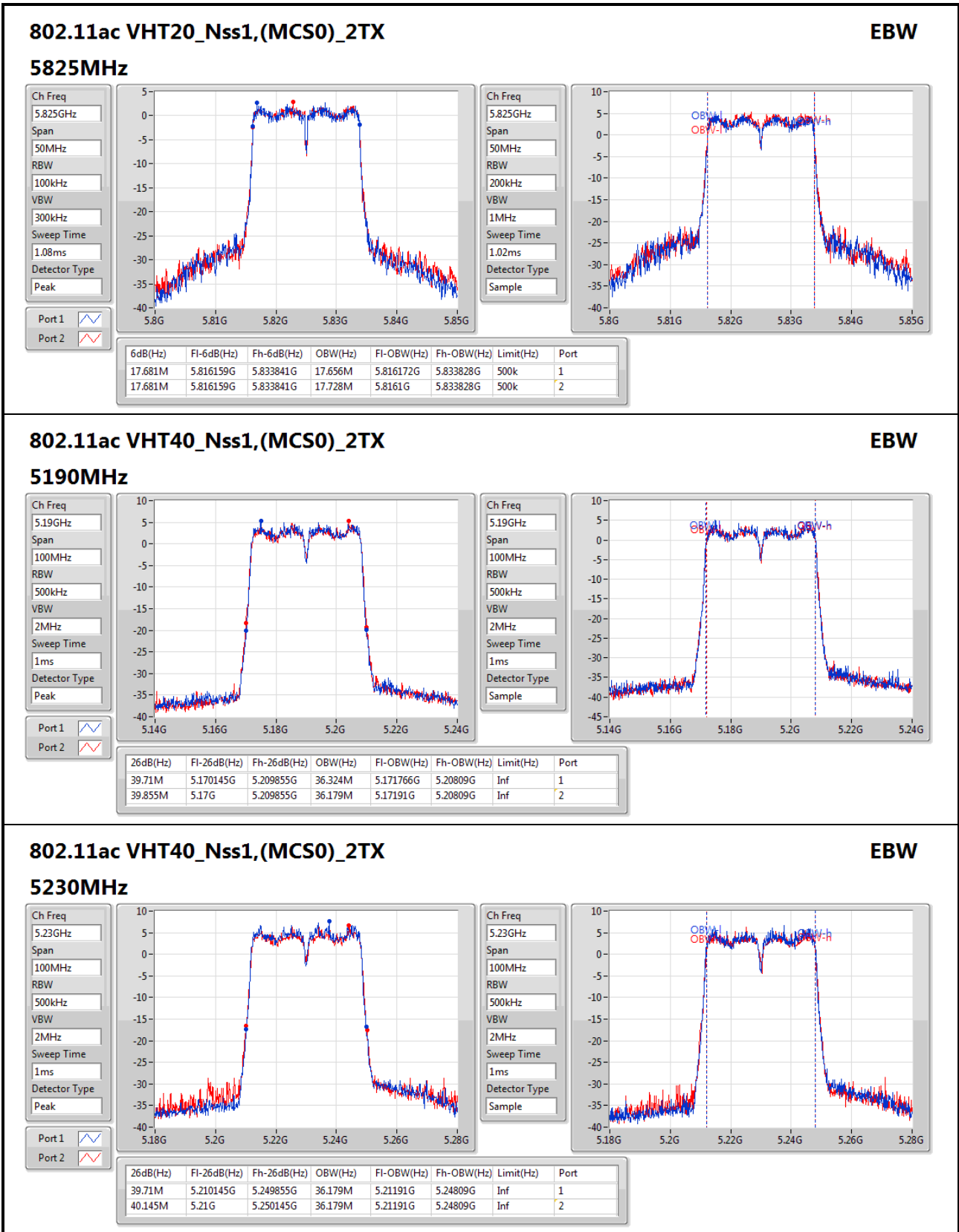
802.11ac VHT40_Nss1,(MCS0)_2TX
EBW

5230MHz

Ch Freq: 5.23GHz
Span: 100MHz
RBW: 500kHz
VBW: 2MHz
Sweep Time: 1ms
Detector Type: Peak

Port 1: 
Port 2: 



Ch Freq: 5.23GHz
Span: 100MHz
RBW: 500kHz
VBW: 2MHz
Sweep Time: 1ms
Detector Type: Sample



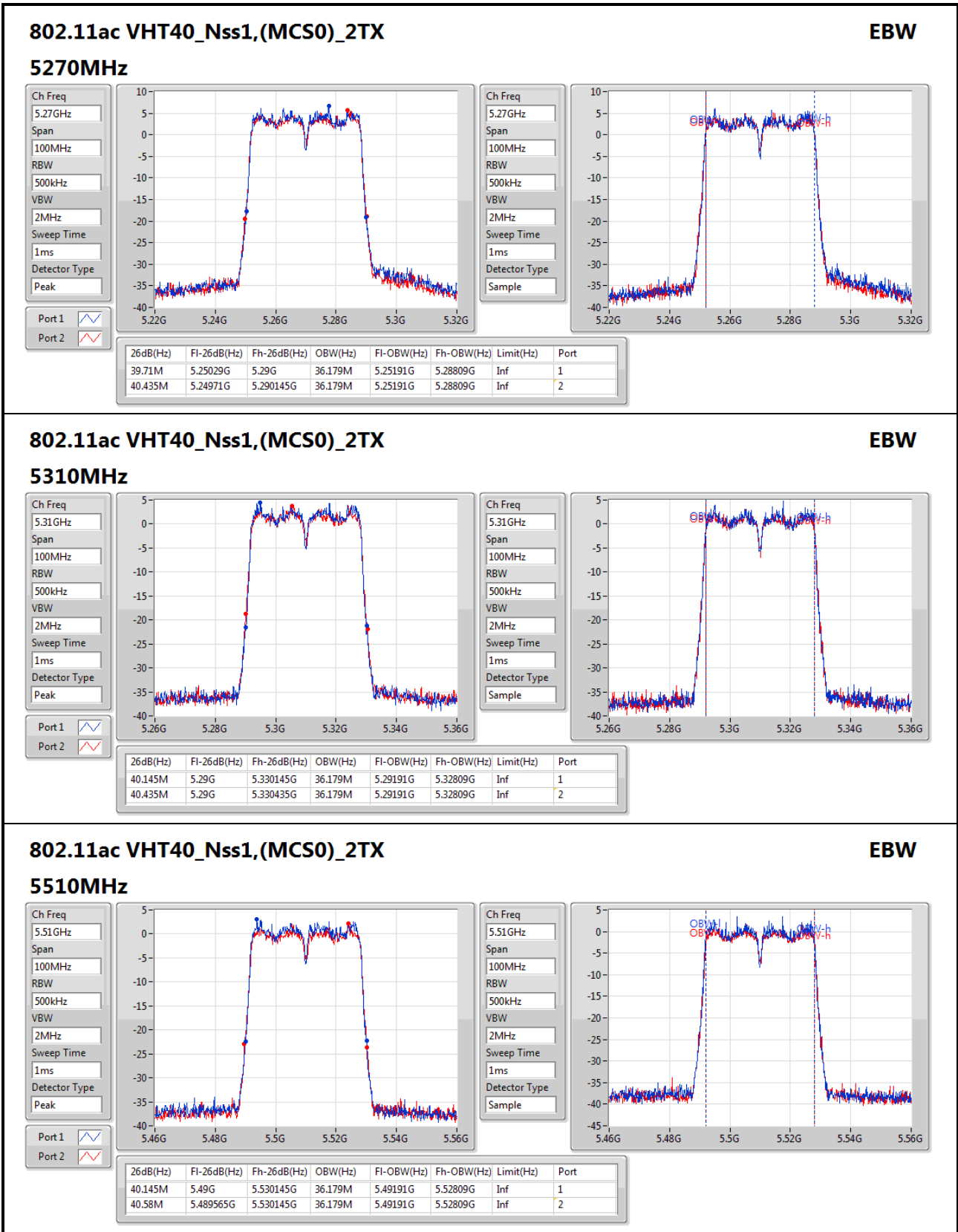

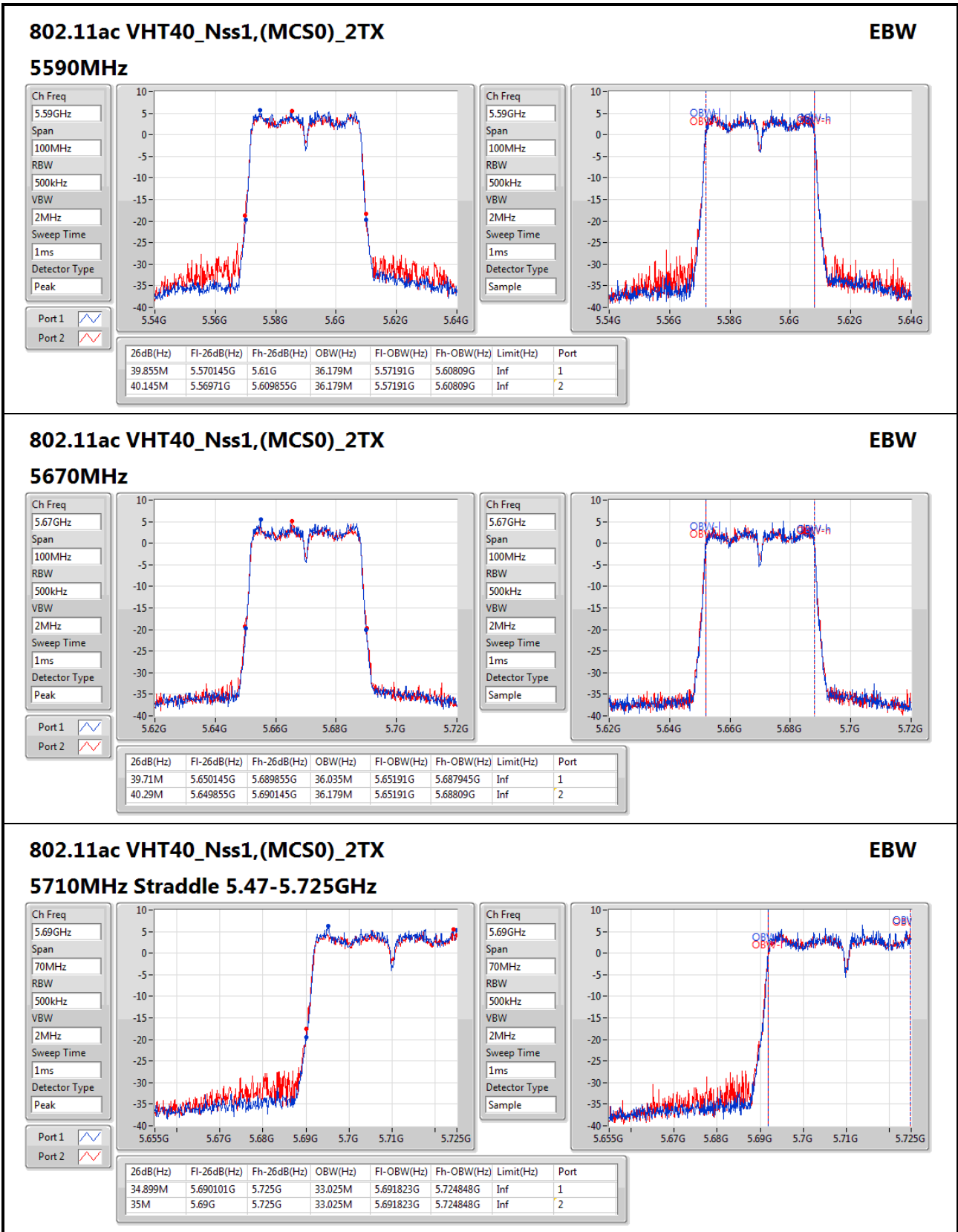

802.11ac VHT40_Nss1,(MCS0)_2TX

EBW

5710MHz Straddle 5.725-5.85GHz

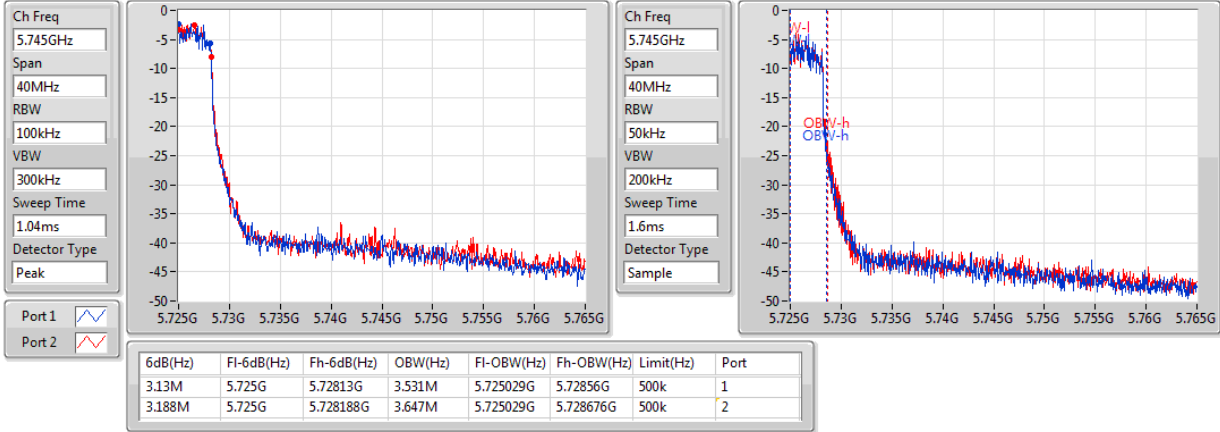

802.11ac VHT40_Nss1,(MCS0)_2TX

EBW

5755MHz

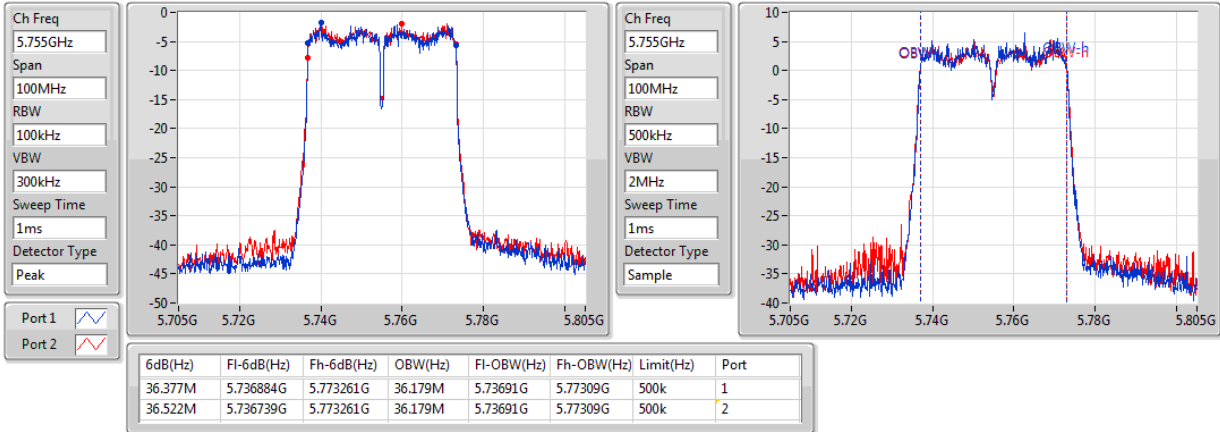

802.11ac VHT40_Nss1,(MCS0)_2TX

EBW

5795MHz

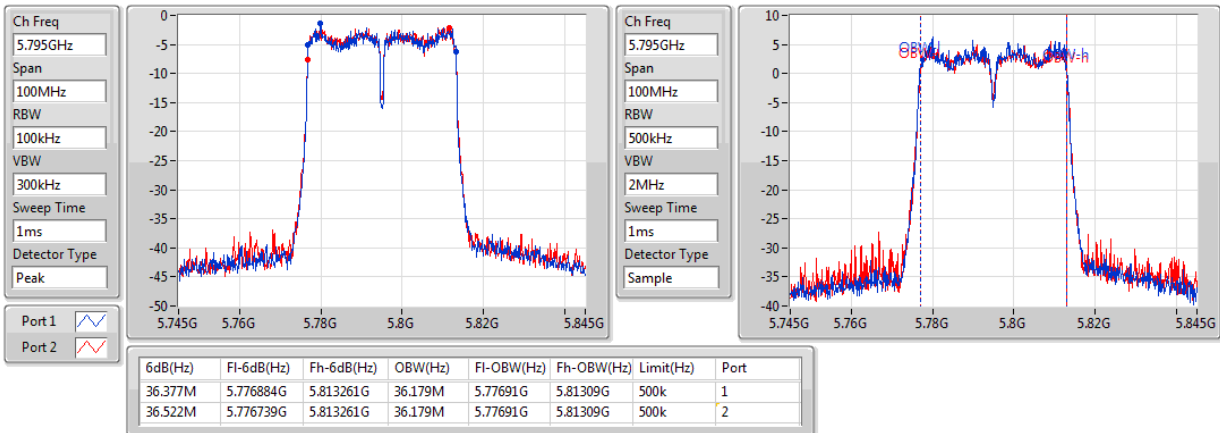

802.11ac VHT80_Nss1,(MCS0)_2TX

EBW

5210MHz

Ch Freq
5.21GHz

Span
200MHz

RBW
1MHz

VBW
3MHz

Sweep Time
1ms

Detector Type
Peak

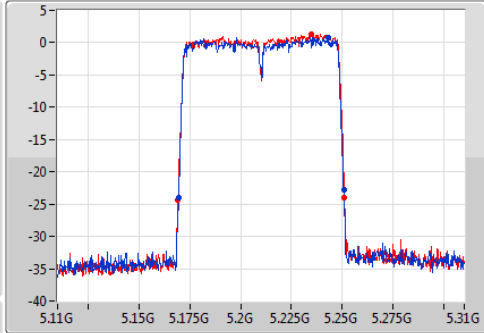

Ch Freq
5.21GHz

Span
200MHz

RBW
1MHz

VBW
3MHz

Sweep Time
1ms

Detector Type
Sample

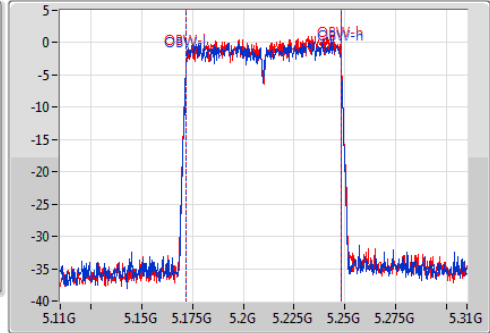

26dB(Hz)	Fl-26dB(Hz)	Fh-26dB(Hz)	OBW(Hz)	Fl-OBW(Hz)	Fh-OBW(Hz)	Limit(Hz)	Port
81.449M	5.16942G	5.25087G	75.832M	5.172084G	5.247916G	Inf	1
82.029M	5.16913G	5.251159G	75.832M	5.172084G	5.247916G	Inf	2

802.11ac VHT80_Nss1,(MCS0)_2TX

EBW

5290MHz

Ch Freq
5.29GHz

Span
200MHz

RBW
1MHz

VBW
3MHz

Sweep Time
1ms

Detector Type
Peak

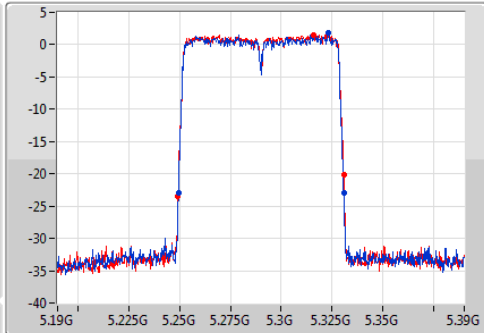

Ch Freq
5.29GHz

Span
200MHz

RBW
1MHz

VBW
3MHz

Sweep Time
1ms

Detector Type
Sample

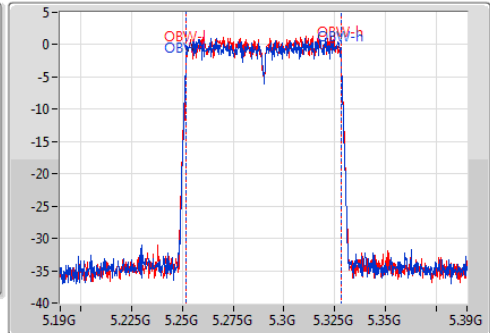

26dB(Hz)	Fl-26dB(Hz)	Fh-26dB(Hz)	OBW(Hz)	Fl-OBW(Hz)	Fh-OBW(Hz)	Limit(Hz)	Port
81.449M	5.24942G	5.33087G	76.122M	5.251795G	5.327916G	Inf	1
81.739M	5.24913G	5.33087G	75.832M	5.252084G	5.327916G	Inf	2

802.11ac VHT80_Nss1,(MCS0)_2TX

EBW

5530MHz

Ch Freq
5.53GHz

Span
200MHz

RBW
1MHz

VBW
3MHz

Sweep Time
1ms

Detector Type
Peak

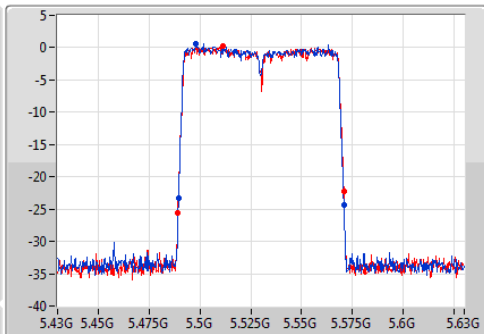

Ch Freq
5.53GHz

Span
200MHz

RBW
1MHz

VBW
3MHz

Sweep Time
1ms

Detector Type
Sample

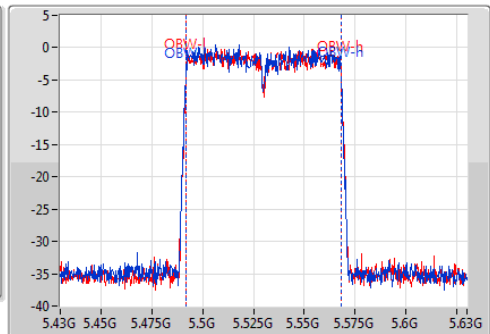

26dB(Hz)	Fl-26dB(Hz)	Fh-26dB(Hz)	OBW(Hz)	Fl-OBW(Hz)	Fh-OBW(Hz)	Limit(Hz)	Port
81.449M	5.48942G	5.57087G	76.122M	5.491795G	5.567916G	Inf	1
81.739M	5.48913G	5.57087G	75.832M	5.492084G	5.567916G	Inf	2

802.11ac VHT80_Nss1,(MCS0)_2TX

EBW

5610MHz

Ch Freq
5.61GHz

Span
200MHz

RBW
1MHz

VBW
3MHz

Sweep Time
1ms

Detector Type
Peak

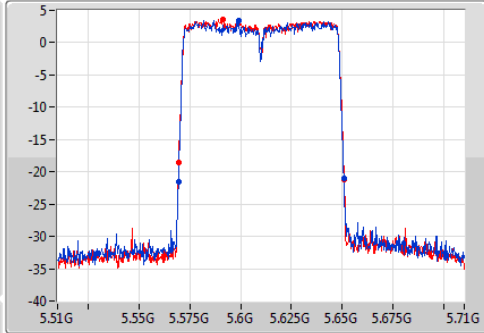

Ch Freq
5.61GHz

Span
200MHz

RBW
1MHz

VBW
3MHz

Sweep Time
1ms

Detector Type
Sample

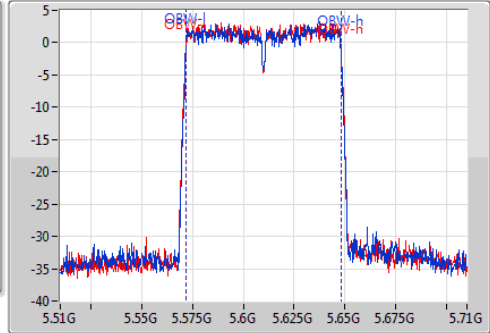

Port1 

Port2 

26dB(Hz)	Fl-26dB(Hz)	Fh-26dB(Hz)	OBW(Hz)	Fl-OBW(Hz)	Fh-OBW(Hz)	Limit(Hz)	Port
81.449M	5.56942G	5.65087G	76.122M	5.571795G	5.647916G	Inf	1
81.739M	5.56942G	5.651159G	75.832M	5.572084G	5.647916G	Inf	2

802.11ac VHT80_Nss1,(MCS0)_2TX

EBW

5690MHz Straddle 5.47-5.725GHz

Ch Freq
5.65GHz

Span
150MHz

RBW
1MHz

VBW
3MHz

Sweep Time
1ms

Detector Type
Peak

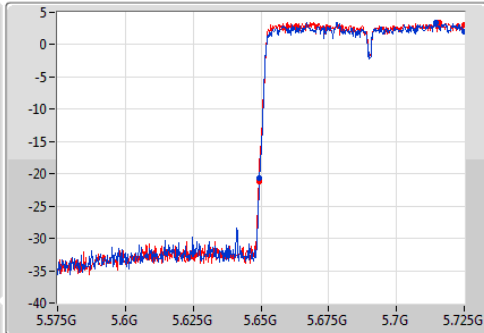

Ch Freq
5.65GHz

Span
150MHz

RBW
1MHz

VBW
3MHz

Sweep Time
1ms

Detector Type
Sample

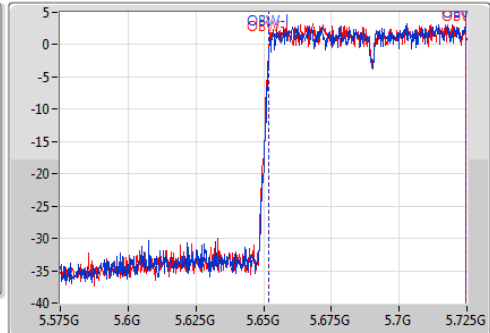

Port1 

Port2 

26dB(Hz)	Fl-26dB(Hz)	Fh-26dB(Hz)	OBW(Hz)	Fl-OBW(Hz)	Fh-OBW(Hz)	Limit(Hz)	Port
75.435M	5.649565G	5.725G	72.721M	5.651954G	5.724674G	Inf	1
75.652M	5.649348G	5.725G	72.721M	5.651954G	5.724674G	Inf	2

802.11ac VHT80_Nss1,(MCS0)_2TX

EBW

5690MHz Straddle 5.725-5.85GHz

Ch Freq
5.745GHz

Span
40MHz

RBW
100kHz

VBW
300kHz

Sweep Time
1.04ms

Detector Type
Peak

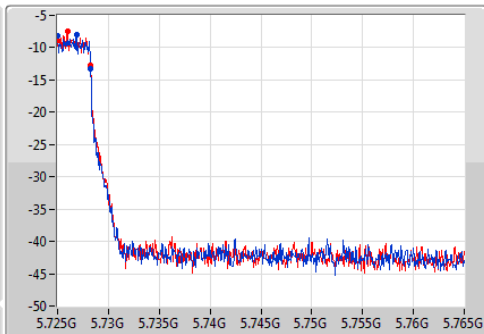

Ch Freq
5.745GHz

Span
40MHz

RBW
100kHz

VBW
300kHz

Sweep Time
1.04ms

Detector Type
Sample

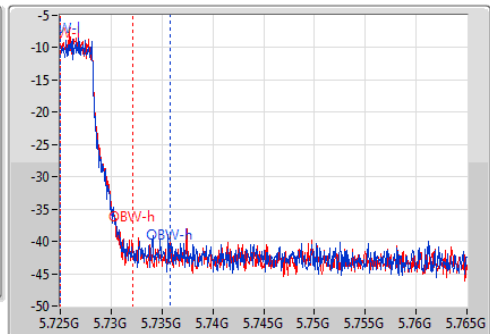

Port1 

Port2 

6dB(Hz)	Fl-6dB(Hz)	Fh-6dB(Hz)	OBW(Hz)	Fl-OBW(Hz)	Fh-OBW(Hz)	Limit(Hz)	Port
3.246M	5.725G	5.728246G	10.825M	5.725029G	5.735854G	500k	1
3.246M	5.725G	5.728246G	7.062M	5.725029G	5.732091G	500k	2

802.11ac VHT80_Nss1,(MCS0)_2TX

EBW

5775MHz

Ch Freq
5.775GHz
Span
200MHz
RBW
100kHz
VBW
300kHz
Sweep Time
2ms
Detector Type
Peak

Port 1 
Port 2 

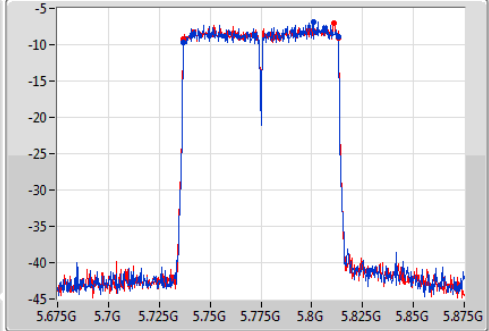

Ch Freq
5.775GHz
Span
200MHz
RBW
1MHz
VBW
3MHz
Sweep Time
1ms
Detector Type
Sample

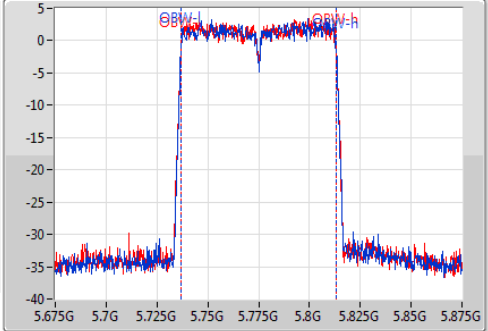

6dB(Hz)	Fl-6dB(Hz)	Fh-6dB(Hz)	OBW(Hz)	Fl-OBW(Hz)	Fh-OBW(Hz)	Limit(Hz)	Port
76.522M	5.736739G	5.813261G	76.122M	5.737084G	5.813205G	500k	1
76.522M	5.736739G	5.813261G	75.832M	5.737084G	5.812916G	500k	2

3.3 RF Output Power

3.3.1 Limit of RF Output Power

Frequency band 5150-5250 MHz		
Operating Mode		Limit
<input type="checkbox"/>	Outdoor access point	Conducted Power: 1 W The maximum e.i.r.p. at any elevation angle above 30 degrees as measured from the horizon must not exceed 125 mW (21 dBm)
<input checked="" type="checkbox"/>	Indoor access point	Conducted Power: 1 W
<input type="checkbox"/>	Fixed point-to-point access points	Conducted Power: 1 W
<input type="checkbox"/>	Client devices	Conducted Power: 250 mW

Frequency Band (MHz)		Limit
<input checked="" type="checkbox"/>	5250 ~ 5350	250mW or 11dBm+10 log B
<input checked="" type="checkbox"/>	5470 ~ 5725	250mW or 11dBm+10 log B
<input checked="" type="checkbox"/>	5725 ~ 5850	1 W

Note: "B" is the 26dB emission bandwidth in MHz.

3.3.2 Test Procedures

Method PM-G (Measurement using a gated RF average power meter)

Measurements is performed using a wideband gated RF power meter provided that the gate parameters are adjusted such that the power is measured only when the EUT is transmitting at its maximum power control level. Since the measurement is made only during the ON time of the transmitter, no duty cycle correction factor is required.

Spectrum analyzer (For channel that extends across the 5.725 GHz boundary)

1. Set RBW = 1MHz, VBW = 3MHz, Sweep time = Auto, Detector = RMS.
2. Trace average at least 100 traces in power averaging mode.
3. Compute power by integrating the spectrum across the 26 dB EBW.
4. Add $10 \log(1/X)$, X:duty cycle) if duty cycle is <98%).

3.3.3 Test Setup

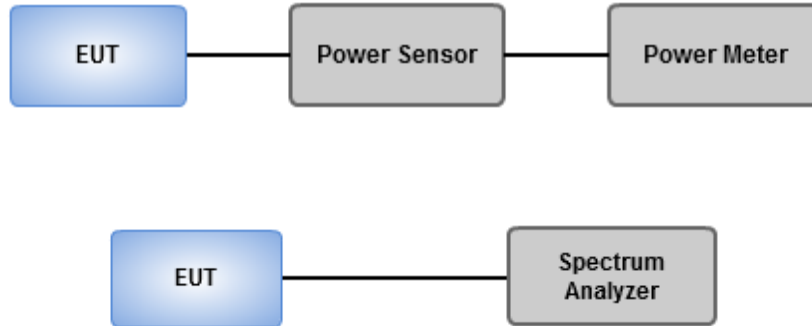

3.3.4 Test Result of Maximum Conducted Output Power

Summary

Mode	Total Power (dBm)	Total Power (W)	EIRP (dBm)	EIRP (W)
5.15-5.25GHz	-	-	-	-
802.11a_Nss1,(6Mbps)_2TX	20.68	0.11695	24.58	0.28708
802.11ac VHT20_Nss1,(MCS0)_2TX	20.89	0.12274	24.79	0.30130
802.11ac VHT40_Nss1,(MCS0)_2TX	18.78	0.07551	22.68	0.18535
802.11ac VHT80_Nss1,(MCS0)_2TX	14.15	0.02600	18.05	0.06383
5.25-5.35GHz	-	-	-	-
802.11a_Nss1,(6Mbps)_2TX	19.00	0.07943	22.90	0.19498
802.11ac VHT20_Nss1,(MCS0)_2TX	19.03	0.07998	22.93	0.19634
802.11ac VHT40_Nss1,(MCS0)_2TX	18.03	0.06353	21.93	0.15596
802.11ac VHT80_Nss1,(MCS0)_2TX	14.45	0.02786	18.35	0.06839
5.47-5.725GHz	-	-	-	-
802.11a_Nss1,(6Mbps)_2TX	20.34	0.10814	24.34	0.27164
802.11ac VHT20_Nss1,(MCS0)_2TX	20.53	0.11298	24.53	0.28379
802.11ac VHT40_Nss1,(MCS0)_2TX	18.50	0.07079	22.50	0.17783
802.11ac VHT80_Nss1,(MCS0)_2TX	16.95	0.04955	20.95	0.12445
5.725-5.85GHz	-	-	-	-
802.11a_Nss1,(6Mbps)_2TX	20.19	0.10447	24.19	0.26242
802.11ac VHT20_Nss1,(MCS0)_2TX	20.36	0.10864	24.36	0.27290
802.11ac VHT40_Nss1,(MCS0)_2TX	18.36	0.06855	22.36	0.17219
802.11ac VHT80_Nss1,(MCS0)_2TX	16.84	0.04831	20.84	0.12134

Result

Mode	Result	DG (dBi)	Port 1 (dBm)	Port 2 (dBm)	Total Power (dBm)	Power Limit (dBm)	EIRP (dBm)	EIRP Limit (dBm)
802.11a_Nss1,(6Mbps)_2TX	-	-	-	-	-	-	-	-
5180MHz	Pass	3.90	15.32	15.41	18.38	24.00	22.28	30.00
5200MHz	Pass	3.90	17.54	17.61	20.59	24.00	24.49	30.00
5240MHz	Pass	3.90	17.64	17.69	20.68	24.00	24.58	30.00
5260MHz	Pass	3.90	15.82	16.01	18.93	23.91	22.83	29.91
5300MHz	Pass	3.90	15.93	16.05	19.00	23.91	22.90	29.91
5320MHz	Pass	3.90	15.01	15.15	18.09	23.90	21.99	29.90
5500MHz	Pass	4.00	15.38	15.09	18.25	23.93	22.25	29.93
5580MHz	Pass	4.00	17.27	17.39	20.34	24.00	24.34	30.00
5700MHz	Pass	4.00	13.33	13.45	16.40	23.91	20.40	29.91
5720MHz Straddle 5.47-5.725GHz	Pass	4.00	15.61	15.82	18.73	23.87	22.73	29.87
5720MHz Straddle 5.725-5.85GHz	Pass	4.00	9.59	9.82	12.72	30.00	16.72	36.00
5745MHz	Pass	4.00	17.06	17.29	20.19	30.00	24.19	36.00
5785MHz	Pass	4.00	17.04	17.21	20.14	30.00	24.14	36.00
5825MHz	Pass	4.00	17.02	17.24	20.14	30.00	24.14	36.00
802.11ac VHT20_Nss1,(MCS0)_2TX	-	-	-	-	-	-	-	-
5180MHz	Pass	3.90	15.44	15.67	18.57	24.00	22.47	30.00
5200MHz	Pass	3.90	17.61	17.72	20.68	24.00	24.58	30.00
5240MHz	Pass	3.90	17.83	17.92	20.89	24.00	24.79	30.00
5260MHz	Pass	3.90	15.94	16.01	18.99	24.00	22.89	30.00
5300MHz	Pass	3.90	15.99	16.04	19.03	23.99	22.93	29.99
5320MHz	Pass	3.90	15.98	16.02	19.01	23.95	22.91	29.95
5500MHz	Pass	4.00	15.45	15.36	18.42	23.99	22.42	29.99
5580MHz	Pass	4.00	17.43	17.61	20.53	24.00	24.53	30.00
5700MHz	Pass	4.00	14.35	14.62	17.50	23.99	21.50	29.99
5720MHz Straddle 5.47-5.725GHz	Pass	4.00	15.63	15.95	18.80	22.75	22.80	28.75
5720MHz Straddle 5.725-5.85GHz	Pass	4.00	10.17	10.45	13.32	30.00	17.32	36.00
5745MHz	Pass	4.00	17.19	17.51	20.36	30.00	24.36	36.00
5785MHz	Pass	4.00	17.17	17.49	20.34	30.00	24.34	36.00
5825MHz	Pass	4.00	17.12	17.51	20.33	30.00	24.33	36.00
802.11ac	-	-	-	-	-	-	-	-

Mode	Result	DG (dBi)	Port 1 (dBm)	Port 2 (dBm)	Total Power (dBm)	Power Limit (dBm)	EIRP (dBm)	EIRP Limit (dBm)
VHT40_Nss1,(MCS0)_2TX								
5190MHz	Pass	3.90	14.42	14.61	17.53	24.00	21.43	30.00
5230MHz	Pass	3.90	15.75	15.78	18.78	24.00	22.68	30.00
5270MHz	Pass	3.90	14.92	15.12	18.03	24.00	21.93	30.00
5310MHz	Pass	3.90	13.02	13.18	16.11	24.00	20.01	30.00
5510MHz	Pass	4.00	12.27	12.45	15.37	24.00	19.37	30.00
5590MHz	Pass	4.00	15.36	15.61	18.50	24.00	22.50	30.00
5670MHz	Pass	4.00	14.25	14.63	17.45	24.00	21.45	30.00
5710MHz Straddle 5.47-5.725GHz	Pass	4.00	14.29	14.64	17.48	24.00	21.48	30.00
5710MHz Straddle 5.725-5.85GHz	Pass	4.00	4.72	4.98	7.86	30.00	11.86	36.00
5755MHz	Pass	4.00	15.21	15.49	18.36	30.00	22.36	36.00
5795MHz	Pass	4.00	15.17	15.49	18.34	30.00	22.34	36.00
802.11ac VHT80_Nss1,(MCS0)_2TX	-	-	-	-	-	-	-	-
5210MHz	Pass	3.90	11.04	11.23	14.15	24.00	18.05	30.00
5290MHz	Pass	3.90	11.37	11.51	14.45	24.00	18.35	30.00
5530MHz	Pass	4.00	10.92	10.73	13.84	24.00	17.84	30.00
5610MHz	Pass	4.00	13.86	14.01	16.95	24.00	20.95	30.00
5690MHz Straddle 5.47-5.725GHz	Pass	4.00	13.07	13.45	16.27	24.00	20.27	30.00
5690MHz Straddle 5.725-5.85GHz	Pass	4.00	-0.36	-0.14	2.76	30.00	6.76	36.00
5775MHz	Pass	4.00	13.63	14.02	16.84	30.00	20.84	36.00

DG = Directional Gain; **Port X** = Port X output power

802.11a_Nss1,(6Mbps)_2TX

AV Power

5720MHz Straddle 5.47-5.725GHz

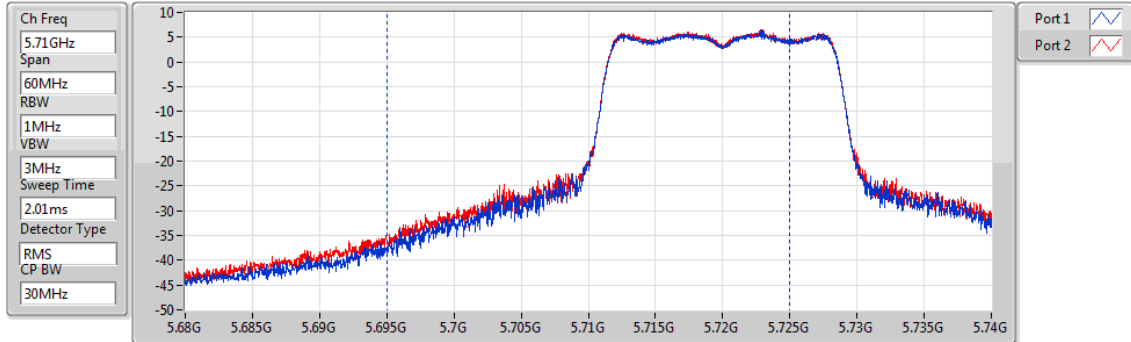

Sum=Total Power
PX=Port X

Sum(dBm)	P1(dBm)	P2(dBm)
18.73	15.61	15.82

802.11a_Nss1,(6Mbps)_2TX

AV Power

5720MHz Straddle 5.725-5.85GHz

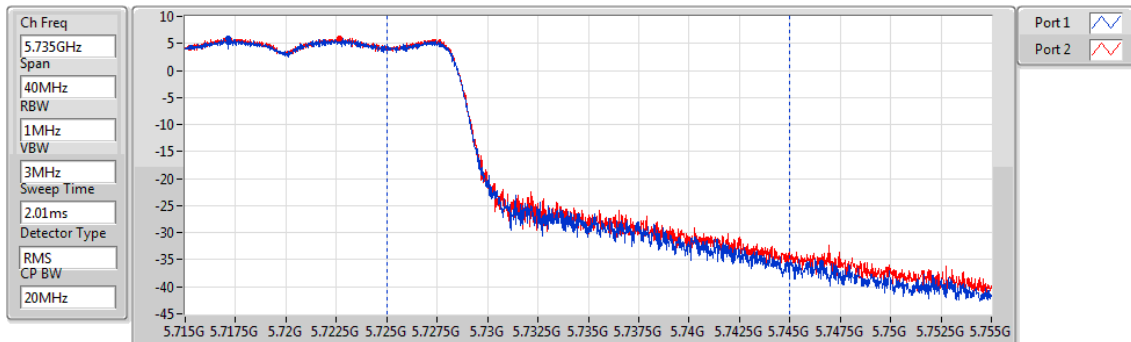

Sum=Total Power
PX=Port X

Sum(dBm)	P1(dBm)	P2(dBm)
12.72	9.59	9.82

802.11ac VHT20_Nss1,(MCS0)_2TX

AV Power

5720MHz Straddle 5.47-5.725GHz

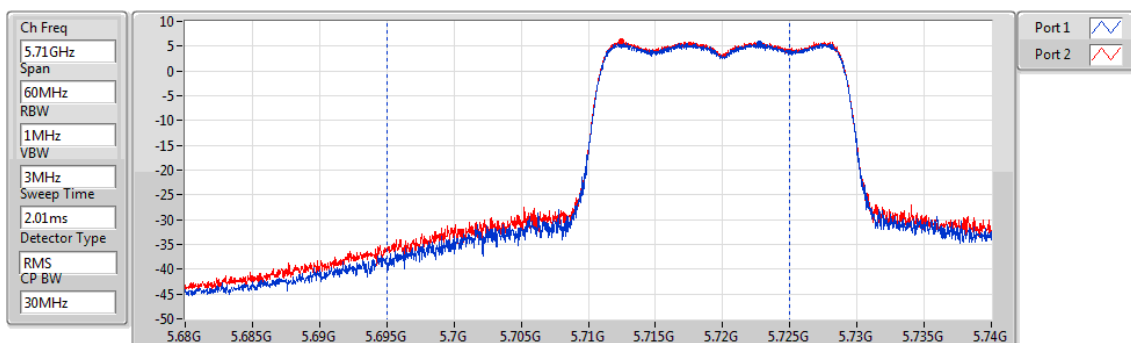

Sum=Total Power
PX=Port X

Sum(dBm)	P1(dBm)	P2(dBm)
18.80	15.63	15.95

802.11ac VHT20_Nss1,(MCS0)_2TX

AV Power

5720MHz Straddle 5.725-5.85GHz

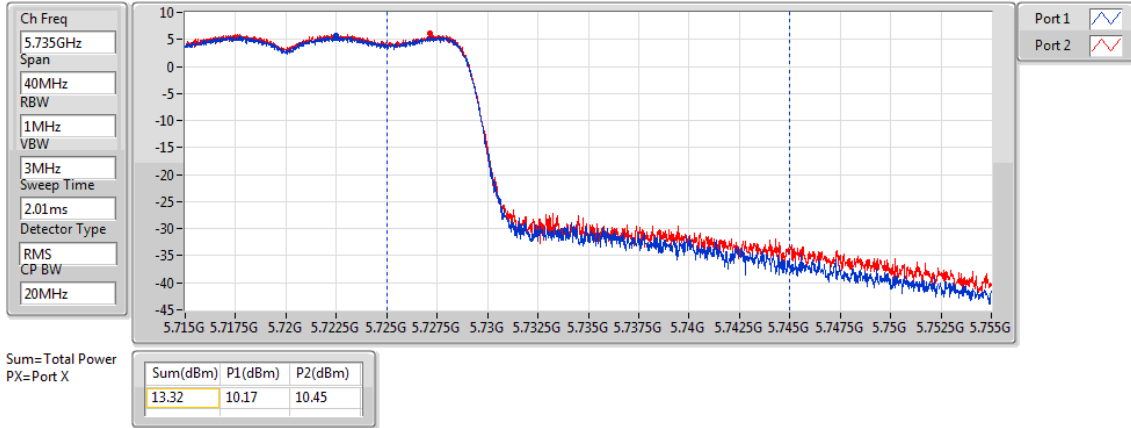

802.11ac VHT40_Nss1,(MCS0)_2TX

AV Power

5710MHz Straddle 5.47-5.725GHz

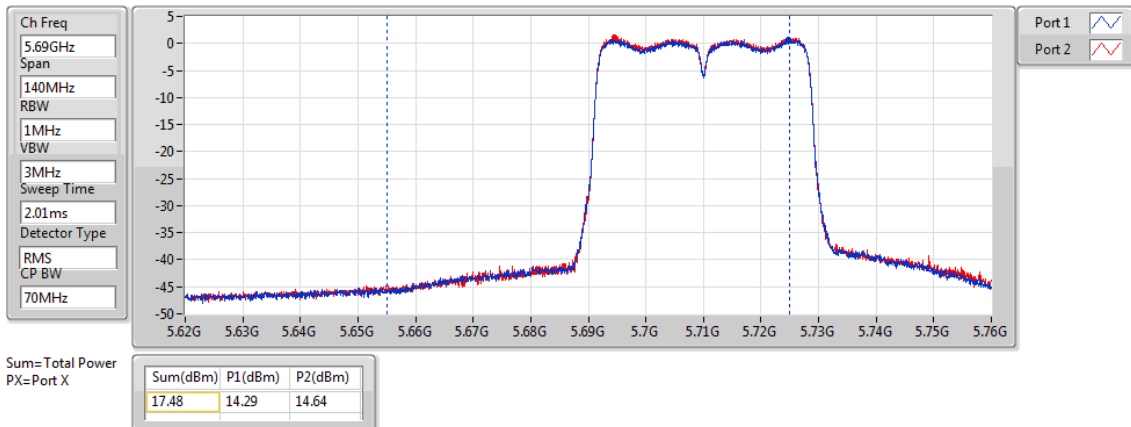

802.11ac VHT40_Nss1,(MCS0)_2TX

AV Power

5710MHz Straddle 5.725-5.85GHz

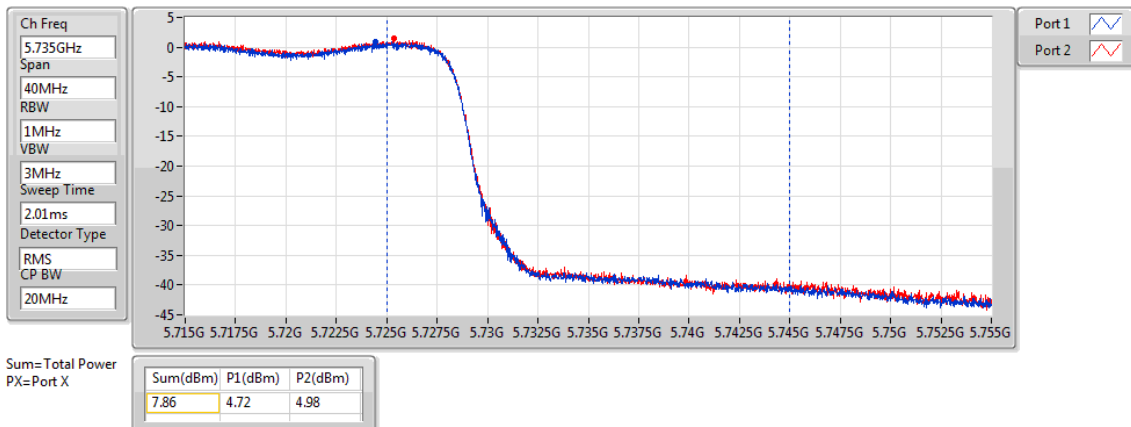

802.11ac VHT80_Nss1,(MCS0)_2TX

AV Power

5690MHz Straddle 5.47-5.725GHz

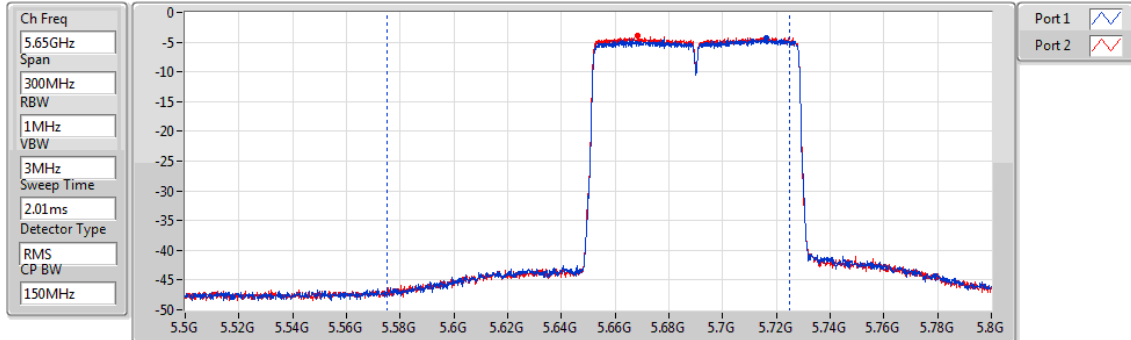

Sum=Total Power
PX=Port X

Sum(dBm)	P1(dBm)	P2(dBm)
16.27	13.07	13.45

802.11ac VHT80_Nss1,(MCS0)_2TX

AV Power

5690MHz Straddle 5.725-5.85GHz

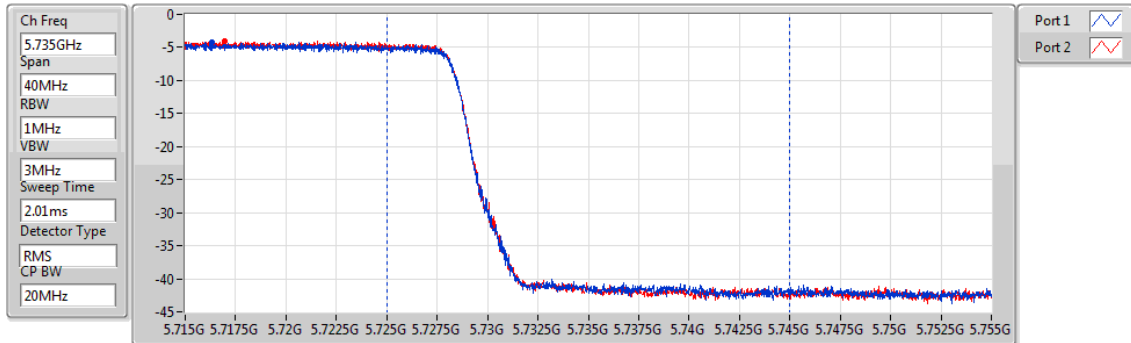

Sum=Total Power
PX=Port X

Sum(dBm)	P1(dBm)	P2(dBm)
2.76	-0.36	-0.14

3.4 Peak Power Spectral Density

3.4.1 Limit of Peak Power Spectral Density

Frequency band 5150-5250 MHz		
Operating Mode		Limit
<input type="checkbox"/>	Outdoor access point	17 dBm / MHz
<input checked="" type="checkbox"/>	Indoor access point	17 dBm / MHz
<input type="checkbox"/>	Fixed point-to-point access points	17 dBm / MHz
<input type="checkbox"/>	Client devices	11 dBm / MHz

Frequency Band (MHz)		Limit
<input checked="" type="checkbox"/>	5250 ~ 5350	11 dBm / MHz
<input checked="" type="checkbox"/>	5470 ~ 5725	11 dBm / MHz
<input checked="" type="checkbox"/>	5725 ~ 5850	30 dBm /500 kHz

3.4.2 Test Procedures

For 5150 ~ 5250 MHz / 5250 ~ 5350 MHz / 5470 ~ 5725 MHz

Duty cycle \geq 98 %

1. Set RBW = 1 MHz, VBW = 3 MHz, Sweep time = auto, Detector = RMS.
2. Trace average 100 traces.
3. Use the peak marker function to determine the maximum amplitude level.

Duty cycle $<$ 98 %

1. Set RBW = 1 MHz, VBW = 3 MHz, Detector = RMS.
2. Set sweep time $\geq 10 * (\text{number of points in sweep}) * (\text{total on/off period of the transmitted signal})$.
3. Perform a single sweep.
4. Use the peak marker function to determine the maximum amplitude level.
5. Add $10 \log(1/x)$, where x is the duty cycle.

For 5725 ~ 5850 MHz

Duty cycle \geq 98 %

1. Set RBW = 500 kHz, VBW = 3 MHz, Sweep time = auto, Detector = RMS.
2. Trace average 100 traces.
3. Use the peak marker function to determine the maximum amplitude level.

Duty cycle $<$ 98 %

1. Set RBW = 500 kHz, VBW = 3 MHz, Detector = RMS.
2. Set sweep time $\geq 10 * (\text{number of points in sweep}) * (\text{total on/off period of the transmitted signal})$.
3. Perform a single sweep.
4. Use the peak marker function to determine the maximum amplitude level.
5. Add $10 \log(1/x)$, where x is the duty cycle.

3.4.3 Test Setup

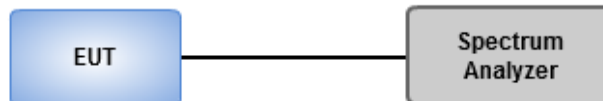

3.4.4 Test Result of Peak Power Spectral Density

Summary

Mode	PD (dBm/RBW)	EIRP PD (dBm/RBW)
5.15-5.25GHz	-	-
802.11a_Nss1,(6Mbps)_2TX	8.13	15.04
802.11ac VHT20_Nss1,(MCS0)_2TX	8.17	15.08
802.11ac VHT40_Nss1,(MCS0)_2TX	2.95	9.86
802.11ac VHT80_Nss1,(MCS0)_2TX	-5.43	1.48
5.25-5.35GHz	-	-
802.11a_Nss1,(6Mbps)_2TX	6.50	13.41
802.11ac VHT20_Nss1,(MCS0)_2TX	6.63	13.54
802.11ac VHT40_Nss1,(MCS0)_2TX	2.20	9.11
802.11ac VHT80_Nss1,(MCS0)_2TX	-5.06	1.85
5.47-5.725GHz	-	-
802.11a_Nss1,(6Mbps)_2TX	7.12	14.13
802.11ac VHT20_Nss1,(MCS0)_2TX	6.97	13.98
802.11ac VHT40_Nss1,(MCS0)_2TX	2.10	9.11
802.11ac VHT80_Nss1,(MCS0)_2TX	-3.01	4.00
5.725-5.85GHz	-	-
802.11a_Nss1,(6Mbps)_2TX	5.74	12.75
802.11ac VHT20_Nss1,(MCS0)_2TX	5.59	12.60
802.11ac VHT40_Nss1,(MCS0)_2TX	0.80	7.81
802.11ac VHT80_Nss1,(MCS0)_2TX	-4.49	2.52

RBW = 500kHz for 5.725-5.85GHz band / 1MHz for other band;

Result

Mode	Result	DG (dBi)	Port 1 (dBm/RB W)	Port 2 (dBm/RB W)	PD (dBm/RB W)	PD Limit (dBm/RB W)	EIRP PD (dBm/RB W)	EIRP PD Limit (dBm/RB W)
802.11a_Nss1,(6Mbps)_2TX	-	-	-	-	-	-	-	-
5180MHz	Pass	6.91	2.39	2.76	5.53	10.09	12.44	17.00
5200MHz	Pass	6.91	4.83	4.94	7.75	10.09	14.66	17.00
5240MHz	Pass	6.91	5.26	5.50	8.13	10.09	15.04	17.00
5260MHz	Pass	6.91	3.49	3.42	6.32	10.09	13.23	17.00
5300MHz	Pass	6.91	3.68	3.61	6.50	10.09	13.41	17.00
5320MHz	Pass	6.91	2.66	2.66	5.50	10.09	12.41	17.00
5500MHz	Pass	7.01	2.51	2.16	5.34	9.99	12.35	17.00
5580MHz	Pass	7.01	4.04	4.58	7.12	9.99	14.13	17.00
5700MHz	Pass	7.01	0.47	0.61	3.39	9.99	10.40	17.00
5720MHz Straddle 5.47-5.725GHz	Pass	7.01	4.05	4.25	7.02	9.99	14.03	17.00
5720MHz Straddle 5.725-5.85GHz	Pass	7.01	2.77	2.78	5.57	28.99	12.58	36.00
5745MHz	Pass	7.01	2.67	3.00	5.54	28.99	12.55	36.00
5785MHz	Pass	7.01	2.63	3.02	5.72	28.99	12.73	36.00
5825MHz	Pass	7.01	2.83	3.18	5.74	28.99	12.75	36.00
802.11ac VHT20_Nss1,(MCS0)_2TX	-	-	-	-	-	-	-	-
5180MHz	Pass	6.91	2.15	2.63	5.30	10.09	12.21	17.00
5200MHz	Pass	6.91	4.72	5.08	7.57	10.09	14.48	17.00
5240MHz	Pass	6.91	5.09	5.34	8.17	10.09	15.08	17.00
5260MHz	Pass	6.91	3.25	3.48	6.20	10.09	13.11	17.00
5300MHz	Pass	6.91	3.56	3.68	6.63	10.09	13.54	17.00
5320MHz	Pass	6.91	3.29	3.62	6.22	10.09	13.13	17.00
5500MHz	Pass	7.01	2.07	2.04	4.92	9.99	11.93	17.00
5580MHz	Pass	7.01	3.95	4.25	6.94	9.99	13.95	17.00
5700MHz	Pass	7.01	0.96	1.50	4.17	9.99	11.18	17.00
5720MHz Straddle 5.47-5.725GHz	Pass	7.01	4.03	4.28	6.97	9.99	13.98	17.00
5720MHz Straddle 5.725-5.85GHz	Pass	7.01	2.59	3.04	5.54	28.99	12.55	36.00
5745MHz	Pass	7.01	2.52	2.86	5.39	28.99	12.40	36.00
5785MHz	Pass	7.01	2.57	2.93	5.55	28.99	12.56	36.00
5825MHz	Pass	7.01	2.52	2.79	5.59	28.99	12.60	36.00
802.11ac VHT40_Nss1,(MCS0)_2TX	-	-	-	-	-	-	-	-
5190MHz	Pass	6.91	-1.65	-0.93	1.74	10.09	8.65	17.00
5230MHz	Pass	6.91	-0.09	0.35	2.95	10.09	9.86	17.00
5270MHz	Pass	6.91	-0.95	-0.43	2.20	10.09	9.11	17.00
5310MHz	Pass	6.91	-2.66	-2.36	0.32	10.09	7.23	17.00
5510MHz	Pass	7.01	-3.84	-4.07	-0.97	9.99	6.04	17.00

Mode	Result	DG (dBi)	Port 1 (dBm/RBW)	Port 2 (dBm/RBW)	PD (dBm/RBW)	PD Limit (dBm/RBW)	EIRP PD (dBm/RBW)	EIRP PD Limit (dBm/RBW)
5590MHz	Pass	7.01	-1.01	-0.66	2.05	9.99	9.06	17.00
5670MHz	Pass	7.01	-1.87	-1.58	1.17	9.99	8.18	17.00
5710MHz Straddle 5.47-5.725GHz	Pass	7.01	-0.87	-0.81	2.10	9.99	9.11	17.00
5710MHz Straddle 5.725-5.85GHz	Pass	7.01	-2.38	-2.02	0.68	28.99	7.69	36.00
5755MHz	Pass	7.01	-2.40	-2.11	0.76	28.99	7.77	36.00
5795MHz	Pass	7.01	-2.17	-1.75	0.80	28.99	7.81	36.00
802.11ac VHT80_Nss1,(MCS0)_2TX	-	-	-	-	-	-	-	-
5210MHz	Pass	6.91	-8.76	-7.82	-5.43	10.09	1.48	17.00
5290MHz	Pass	6.91	-8.00	-7.69	-5.06	10.09	1.85	17.00
5530MHz	Pass	7.01	-9.03	-9.19	-6.18	9.99	0.83	17.00
5610MHz	Pass	7.01	-6.13	-5.94	-3.13	9.99	3.88	17.00
5690MHz Straddle 5.47-5.725GHz	Pass	7.01	-6.00	-5.80	-3.01	9.99	4.00	17.00
5690MHz Straddle 5.725-5.85GHz	Pass	7.01	-7.86	-7.61	-4.83	28.99	2.18	36.00
5775MHz	Pass	7.01	-7.51	-7.29	-4.49	28.99	2.52	36.00

DG = Directional Gain; **RBW** = 500kHz for 5.725-5.85GHz band / 1MHz for other band;

PD = trace bin-by-bin of each transmits port summing can be performed maximum power density; **Port X** = Port Xpower density;

Test results of each port are measured value with duty factor

For 5.15 ~ 5.35 GHz band

Directional gain = $3.9 \text{ dBi} + 10 \cdot \log(2/1) = 6.91 \text{ dBi} > 6 \text{ dBi}$, limit shall be reduced to 11 dBm – (6.91 dBi – 6 dBi) = 10.09 dBm

For 5.47 ~ 5.725 GHz band

Directional gain = $4 \text{ dBi} + 10 \cdot \log(2/1) = 7.01 \text{ dBi} > 6 \text{ dBi}$, limit shall be reduced to 11 dBm – (7.01 dBi = 6 dBi) = 9.99 dBm

For 5.725 ~ 5.85 GHz band

Directional gain = $4 \text{ dBi} + 10 \cdot \log(2/1) = 7.01 \text{ dBi} > 6 \text{ dBi}$, limit shall be reduced to 30 dBm – (7.01 dBi = 6 dBi) = 28.99 dBm

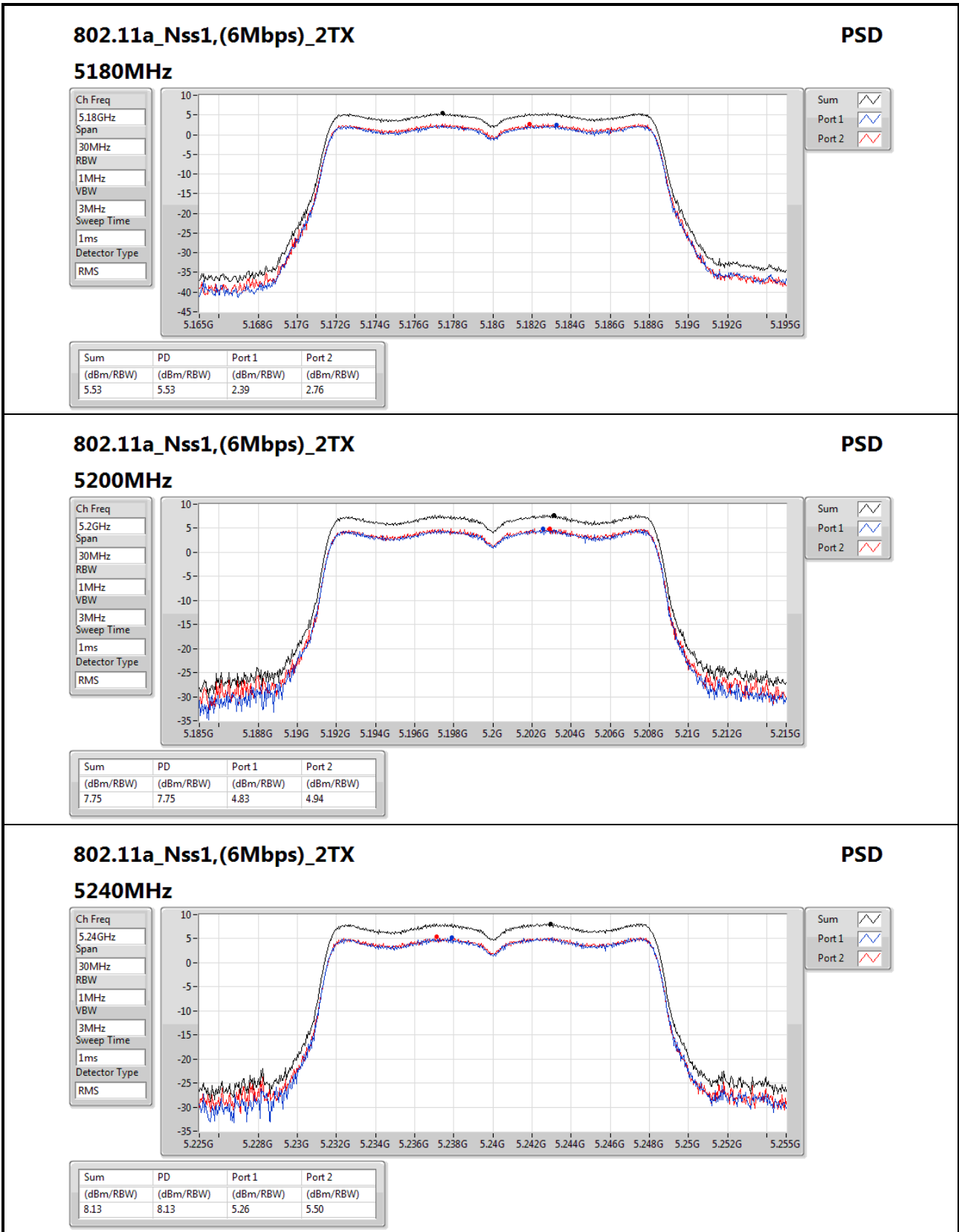

802.11a_Nss1,(6Mbps)_2TX

PSD

5260MHz

Ch Freq
5.26GHz
Span
30MHz
RBW
1MHz
VBW
3MHz
Sweep Time
1ms
Detector Type
RMS

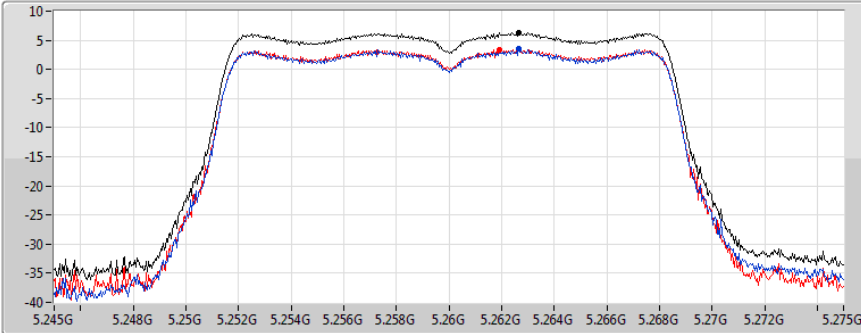

Sum
Port 1
Port 2

Sum	PD	Port 1	Port 2
(dBm/RBW)	(dBm/RBW)	(dBm/RBW)	(dBm/RBW)
6.32	6.32	3.49	3.42

802.11a_Nss1,(6Mbps)_2TX

PSD

5300MHz

Ch Freq
5.3GHz
Span
30MHz
RBW
1MHz
VBW
3MHz
Sweep Time
1ms
Detector Type
RMS

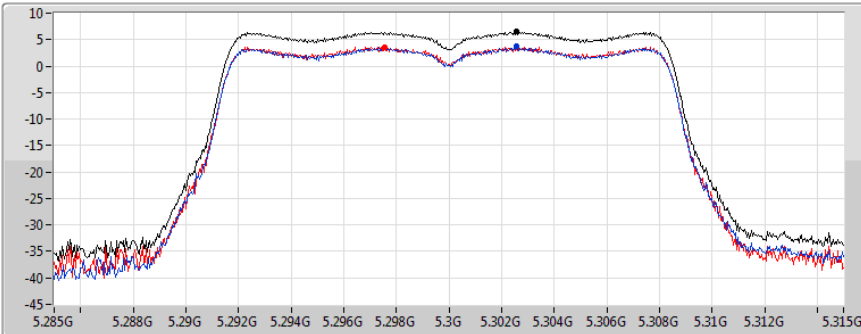

Sum
Port 1
Port 2

Sum	PD	Port 1	Port 2
(dBm/RBW)	(dBm/RBW)	(dBm/RBW)	(dBm/RBW)
6.50	6.50	3.68	3.61

802.11a_Nss1,(6Mbps)_2TX

PSD

5320MHz

Ch Freq
5.32GHz
Span
30MHz
RBW
1MHz
VBW
3MHz
Sweep Time
1ms
Detector Type
RMS

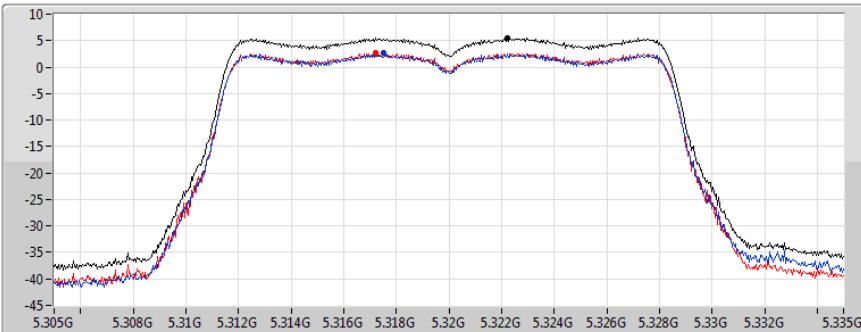

Sum
Port 1
Port 2

Sum	PD	Port 1	Port 2
(dBm/RBW)	(dBm/RBW)	(dBm/RBW)	(dBm/RBW)
5.50	5.50	2.66	2.66

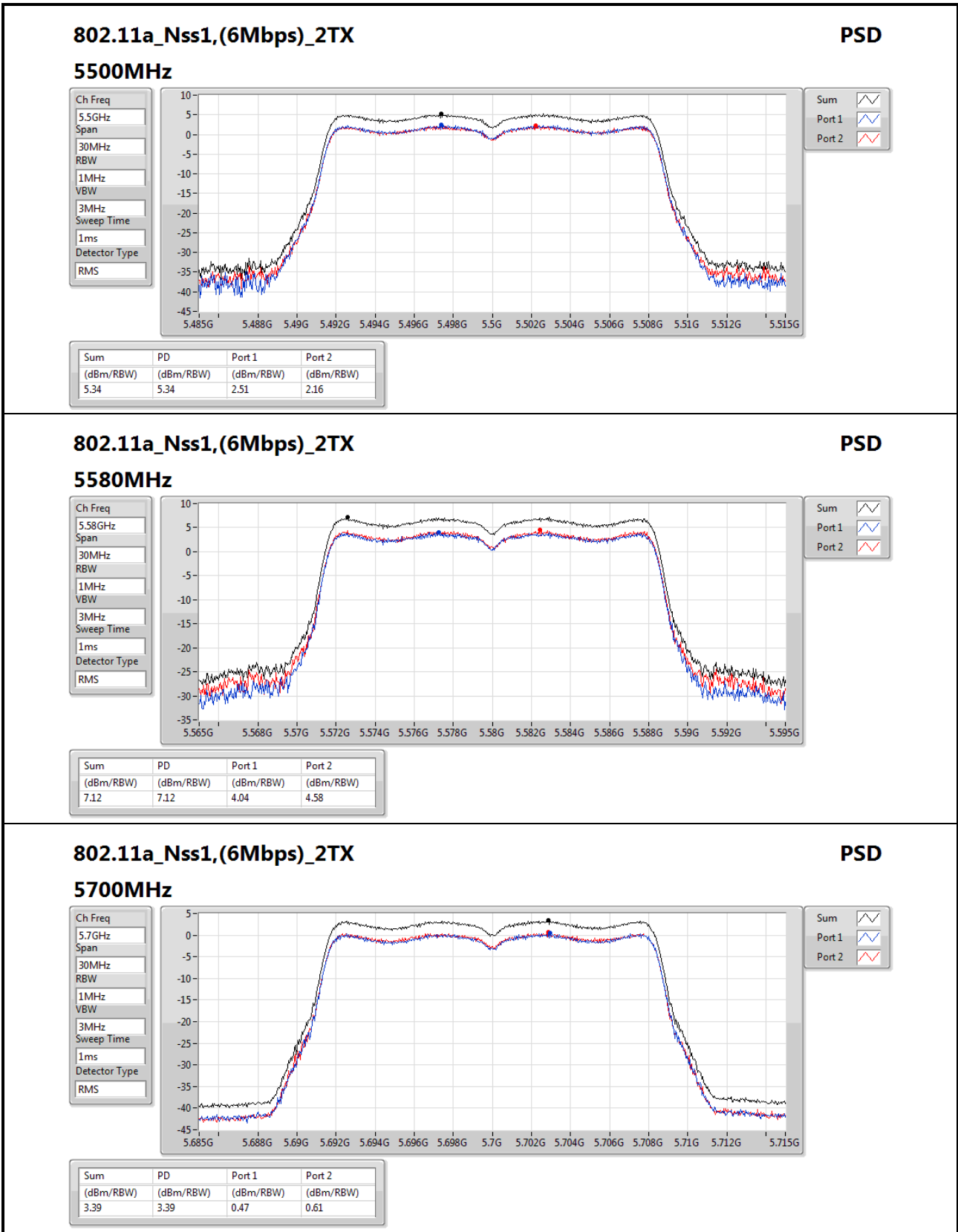
802.11a_Nss1,(6Mbps)_2TX
PSD

5700MHz

Ch Freq
5.7GHz

Span
30MHz

RBW
1MHz

VBW
3MHz

Sweep Time
1ms

Detector Type
RMS



Sum

Port 1

Port 2

Sum	PD	Port 1	Port 2
(dBm/RBW)	(dBm/RBW)	(dBm/RBW)	(dBm/RBW)
3.39	3.39	0.47	0.61

802.11a_Nss1,(6Mbps)_2TX

PSD

5720MHz Straddle 5.47-5.725GHz

Ch Freq	5.71GHz
Span	60MHz
RBW	1MHz
VBW	3MHz
Sweep Time	1ms
Detector Type	RMS

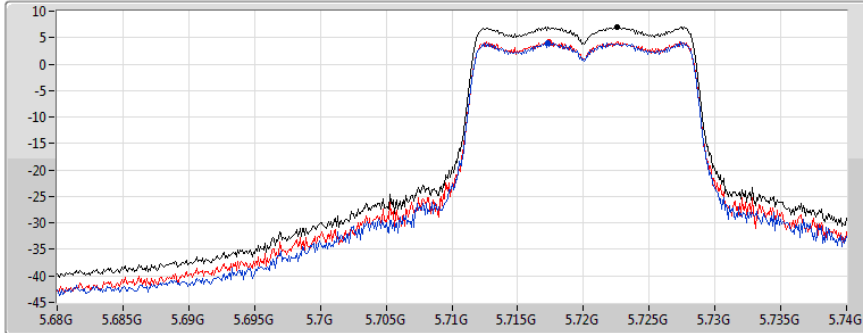

Sum	
Port 1	
Port 2	

Sum	PD	Port 1	Port 2
(dBm/RBW)	(dBm/RBW)	(dBm/RBW)	(dBm/RBW)
7.02	7.02	4.05	4.25

802.11a_Nss1,(6Mbps)_2TX

PSD

5720MHz Straddle 5.725-5.85GHz

Ch Freq	5.735GHz
Span	40MHz
RBW	500kHz
VBW	3MHz
Sweep Time	1ms
Detector Type	RMS

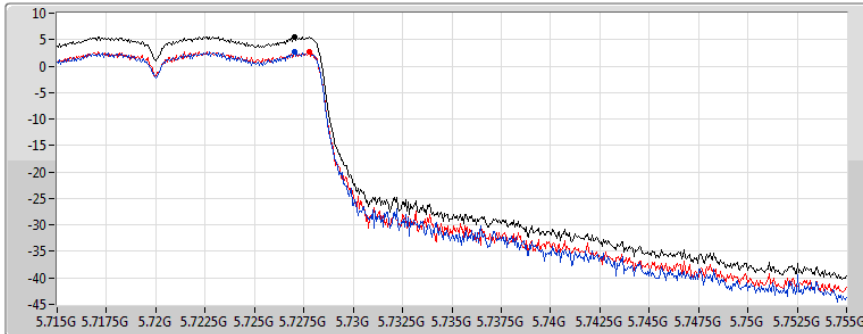

Sum	
Port 1	
Port 2	

Sum	PD	Port 1	Port 2
(dBm/RBW)	(dBm/RBW)	(dBm/RBW)	(dBm/RBW)
5.57	5.57	2.77	2.78

802.11a_Nss1,(6Mbps)_2TX

PSD

5745MHz

Ch Freq	5.745GHz
Span	30MHz
RBW	500kHz
VBW	3MHz
Sweep Time	1ms
Detector Type	RMS

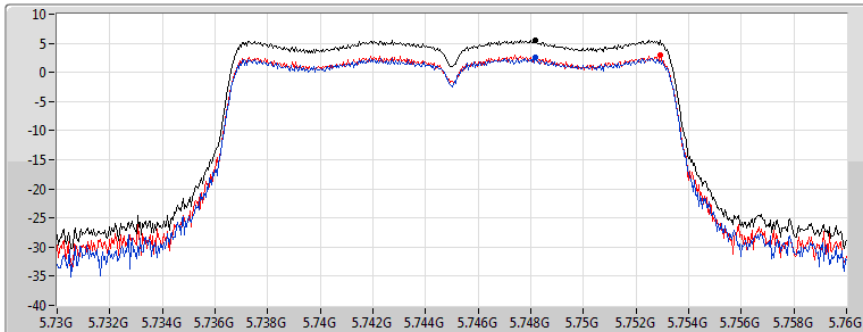

Sum	
Port 1	
Port 2	

Sum	PD	Port 1	Port 2
(dBm/RBW)	(dBm/RBW)	(dBm/RBW)	(dBm/RBW)
5.54	5.54	2.67	3.00

802.11a_Nss1,(6Mbps)_2TX

PSD

5785MHz

Ch Freq
5.785GHz
Span
30MHz
RBW
500kHz
VBW
3MHz
Sweep Time
1ms
Detector Type
RMS

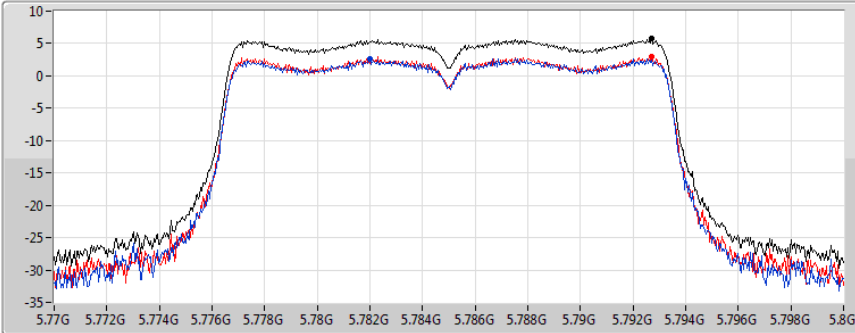

Sum
Port 1
Port 2

Sum	PD	Port 1	Port 2
(dBm/RBW)	(dBm/RBW)	(dBm/RBW)	(dBm/RBW)
5.72	5.72	2.63	3.02

802.11a_Nss1,(6Mbps)_2TX

PSD

5825MHz

Ch Freq
5.825GHz
Span
30MHz
RBW
500kHz
VBW
3MHz
Sweep Time
1ms
Detector Type
RMS

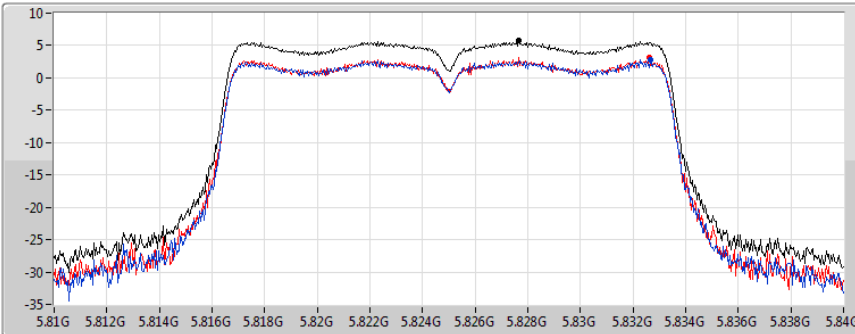

Sum
Port 1
Port 2

Sum	PD	Port 1	Port 2
(dBm/RBW)	(dBm/RBW)	(dBm/RBW)	(dBm/RBW)
5.74	5.74	2.83	3.18

802.11ac VHT20_Nss1,(MCS0)_2TX

PSD

5180MHz

Ch Freq
5.18GHz
Span
30MHz
RBW
1MHz
VBW
3MHz
Sweep Time
1ms
Detector Type
RMS

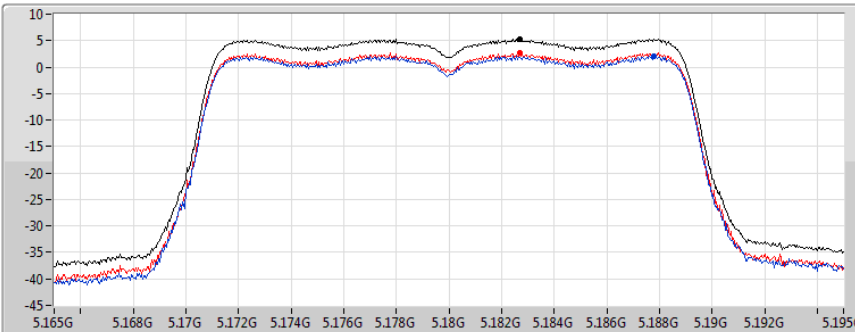

Sum
Port 1
Port 2

Sum	PD	Port 1	Port 2
(dBm/RBW)	(dBm/RBW)	(dBm/RBW)	(dBm/RBW)
5.30	5.30	2.15	2.63

802.11ac VHT20_Nss1,(MCS0)_2TX

PSD

5200MHz

Ch Freq
5.2GHz
Span
30MHz
RBW
1MHz
VBW
3MHz
Sweep Time
1ms
Detector Type
RMS

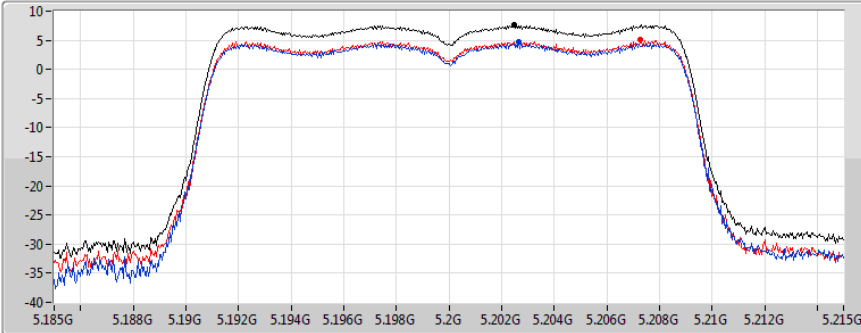

Sum
Port 1
Port 2

Sum	PD	Port 1	Port 2
(dBm/RBW)	(dBm/RBW)	(dBm/RBW)	(dBm/RBW)
7.57	7.57	4.72	5.08

802.11ac VHT20_Nss1,(MCS0)_2TX

PSD

5240MHz

Ch Freq
5.24GHz
Span
30MHz
RBW
1MHz
VBW
3MHz
Sweep Time
1ms
Detector Type
RMS

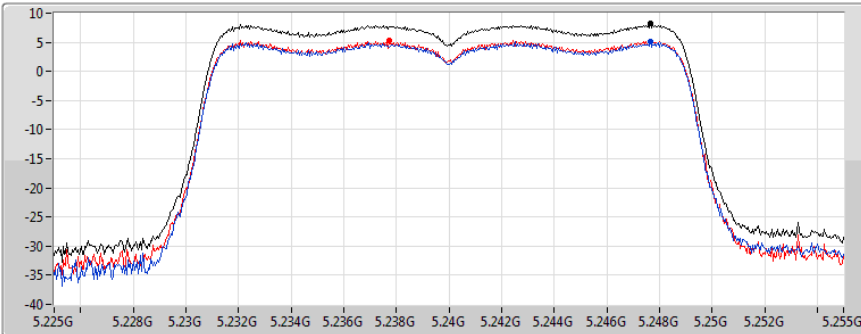

Sum
Port 1
Port 2

Sum	PD	Port 1	Port 2
(dBm/RBW)	(dBm/RBW)	(dBm/RBW)	(dBm/RBW)
8.17	8.17	5.09	5.34

802.11ac VHT20_Nss1,(MCS0)_2TX

PSD

5260MHz

Ch Freq
5.26GHz
Span
30MHz
RBW
1MHz
VBW
3MHz
Sweep Time
1ms
Detector Type
RMS

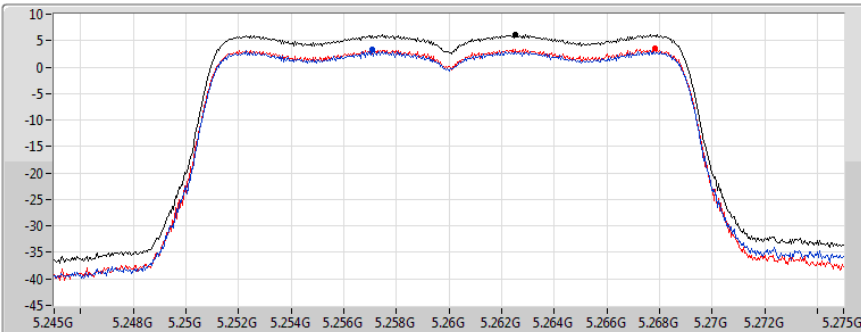

Sum
Port 1
Port 2

Sum	PD	Port 1	Port 2
(dBm/RBW)	(dBm/RBW)	(dBm/RBW)	(dBm/RBW)
6.20	6.20	3.25	3.48

802.11ac VHT20_Nss1,(MCS0)_2TX

PSD

5300MHz

Ch Freq
5.3GHz
Span
30MHz
RBW
1MHz
VBW
3MHz
Sweep Time
1ms
Detector Type
RMS

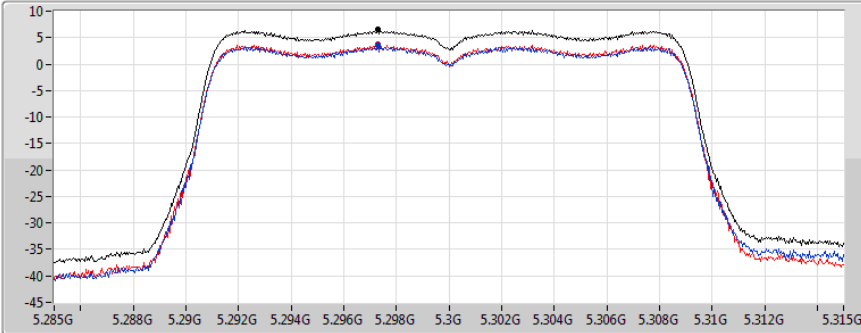

Sum
Port 1
Port 2

Sum	PD	Port 1	Port 2
(dBm/RBW)	(dBm/RBW)	(dBm/RBW)	(dBm/RBW)
6.63	6.63	3.56	3.68

802.11ac VHT20_Nss1,(MCS0)_2TX

PSD

5320MHz

Ch Freq
5.32GHz
Span
30MHz
RBW
1MHz
VBW
3MHz
Sweep Time
1ms
Detector Type
RMS

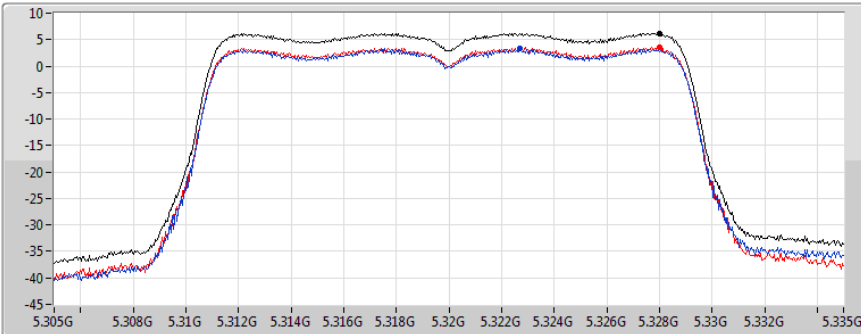

Sum
Port 1
Port 2

Sum	PD	Port 1	Port 2
(dBm/RBW)	(dBm/RBW)	(dBm/RBW)	(dBm/RBW)
6.22	6.22	3.29	3.62

802.11ac VHT20_Nss1,(MCS0)_2TX

PSD

5500MHz

Ch Freq
5.5GHz
Span
30MHz
RBW
1MHz
VBW
3MHz
Sweep Time
1ms
Detector Type
RMS

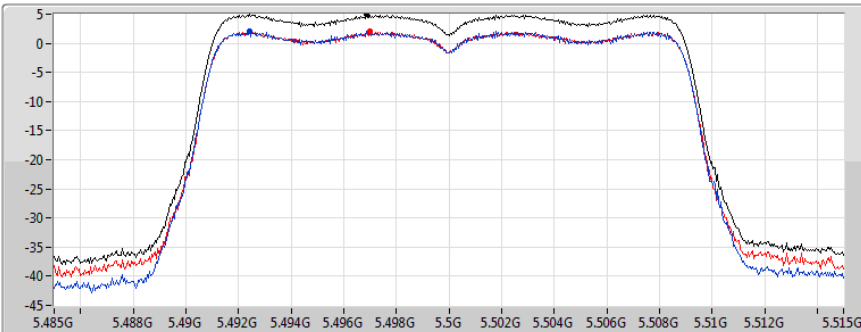

Sum
Port 1
Port 2

Sum	PD	Port 1	Port 2
(dBm/RBW)	(dBm/RBW)	(dBm/RBW)	(dBm/RBW)
4.92	4.92	2.07	2.04

802.11ac VHT20_Nss1,(MCS0)_2TX

PSD

5580MHz

Ch Freq
5.58GHz
Span
30MHz
RBW
1MHz
VBW
3MHz
Sweep Time
1ms
Detector Type
RMS

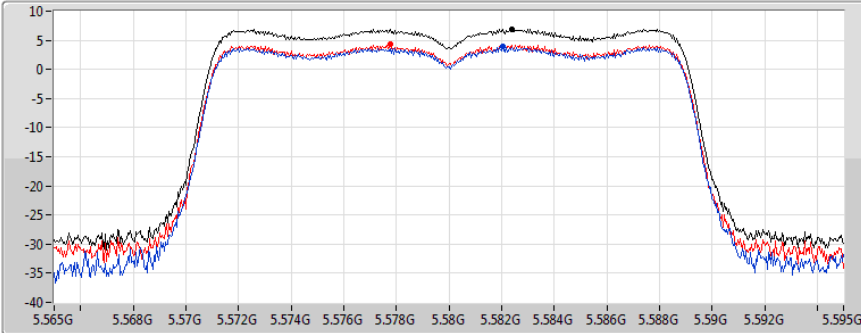

Sum
Port 1
Port 2

Sum	PD	Port 1	Port 2
(dBm/RBW)	(dBm/RBW)	(dBm/RBW)	(dBm/RBW)
6.94	6.94	3.95	4.25

802.11ac VHT20_Nss1,(MCS0)_2TX

PSD

5700MHz

Ch Freq
5.7GHz
Span
30MHz
RBW
1MHz
VBW
3MHz
Sweep Time
1ms
Detector Type
RMS

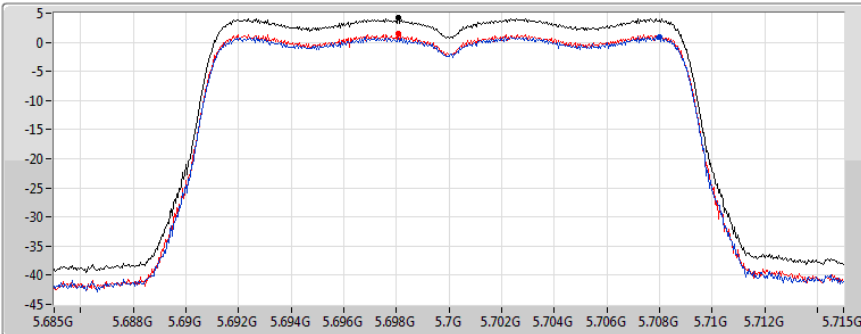

Sum
Port 1
Port 2

Sum	PD	Port 1	Port 2
(dBm/RBW)	(dBm/RBW)	(dBm/RBW)	(dBm/RBW)
4.17	4.17	0.96	1.50

802.11ac VHT20_Nss1,(MCS0)_2TX

PSD

5720MHz Straddle 5.47-5.725GHz

Ch Freq
5.71GHz
Span
60MHz
RBW
1MHz
VBW
3MHz
Sweep Time
1ms
Detector Type
RMS

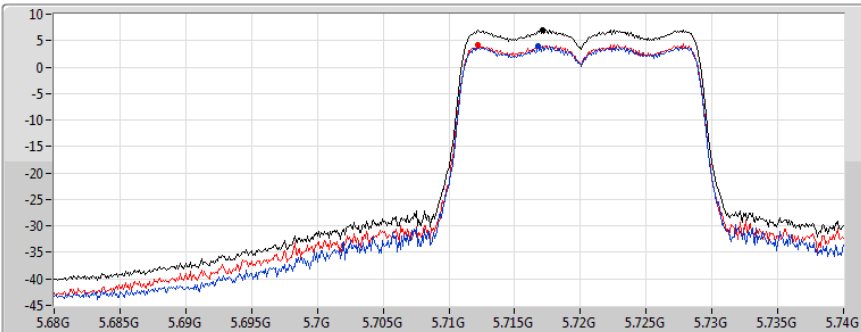

Sum
Port 1
Port 2

Sum	PD	Port 1	Port 2
(dBm/RBW)	(dBm/RBW)	(dBm/RBW)	(dBm/RBW)
6.97	6.97	4.03	4.28

802.11ac VHT20_Nss1,(MCS0)_2TX

PSD

5720MHz Straddle 5.725-5.85GHz

Ch Freq	5.735GHz
Span	40MHz
RBW	500kHz
VBW	3MHz
Sweep Time	1ms
Detector Type	RMS

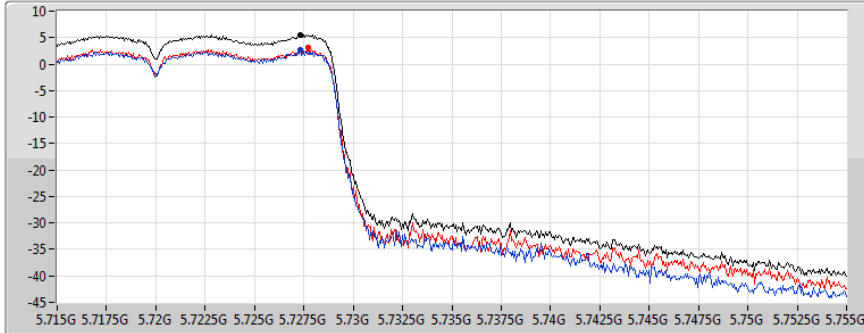

Sum	
Port 1	
Port 2	

Sum	PD	Port 1	Port 2
(dBm/RBW)	(dBm/RBW)	(dBm/RBW)	(dBm/RBW)
5.54	5.54	2.59	3.04

802.11ac VHT20_Nss1,(MCS0)_2TX

PSD

5745MHz

Ch Freq	5.745GHz
Span	30MHz
RBW	500kHz
VBW	3MHz
Sweep Time	1ms
Detector Type	RMS

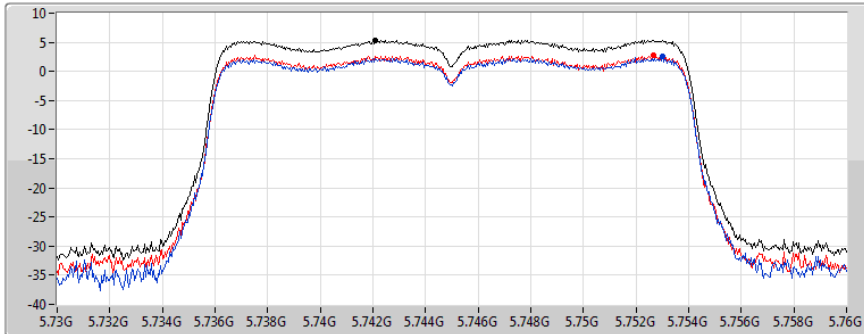

Sum	
Port 1	
Port 2	

Sum	PD	Port 1	Port 2
(dBm/RBW)	(dBm/RBW)	(dBm/RBW)	(dBm/RBW)
5.39	5.39	2.52	2.86

802.11ac VHT20_Nss1,(MCS0)_2TX

PSD

5785MHz

Ch Freq	5.785GHz
Span	30MHz
RBW	500kHz
VBW	3MHz
Sweep Time	1ms
Detector Type	RMS

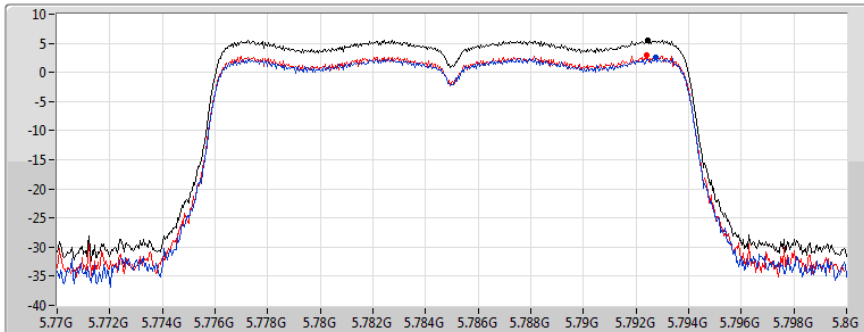

Sum	
Port 1	
Port 2	

Sum	PD	Port 1	Port 2
(dBm/RBW)	(dBm/RBW)	(dBm/RBW)	(dBm/RBW)
5.55	5.55	2.57	2.93

802.11ac VHT20_Nss1,(MCS0)_2TX

PSD

5825MHz

Ch Freq
5.825GHz
Span
30MHz
RBW
500kHz
VBW
3MHz
Sweep Time
1ms
Detector Type
RMS

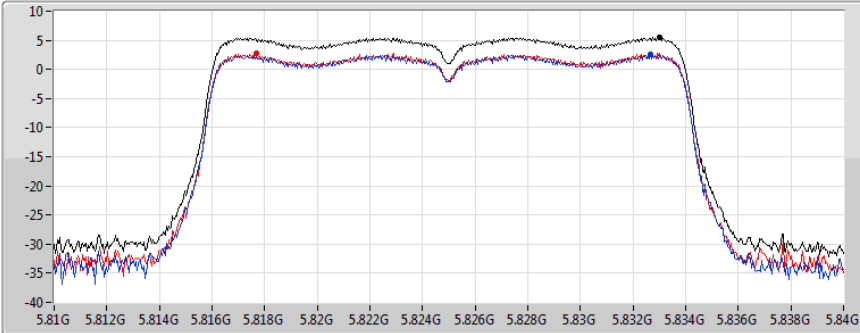

Sum
Port 1
Port 2

Sum	PD	Port 1	Port 2
(dBm/RBW)	(dBm/RBW)	(dBm/RBW)	(dBm/RBW)
5.59	5.59	2.52	2.79

802.11ac VHT40_Nss1,(MCS0)_2TX

PSD

5190MHz

Ch Freq
5.19GHz
Span
60MHz
RBW
1MHz
VBW
3MHz
Sweep Time
1ms
Detector Type
RMS

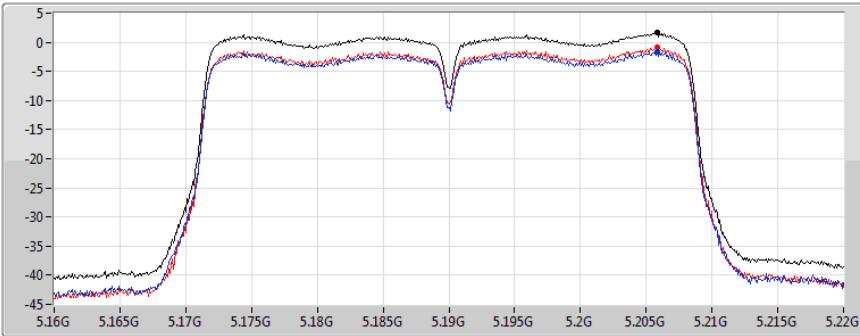

Sum
Port 1
Port 2

Sum	PD	Port 1	Port 2
(dBm/RBW)	(dBm/RBW)	(dBm/RBW)	(dBm/RBW)
1.74	1.74	-1.65	-0.93

802.11ac VHT40_Nss1,(MCS0)_2TX

PSD

5230MHz

Ch Freq
5.23GHz
Span
60MHz
RBW
1MHz
VBW
3MHz
Sweep Time
1ms
Detector Type
RMS

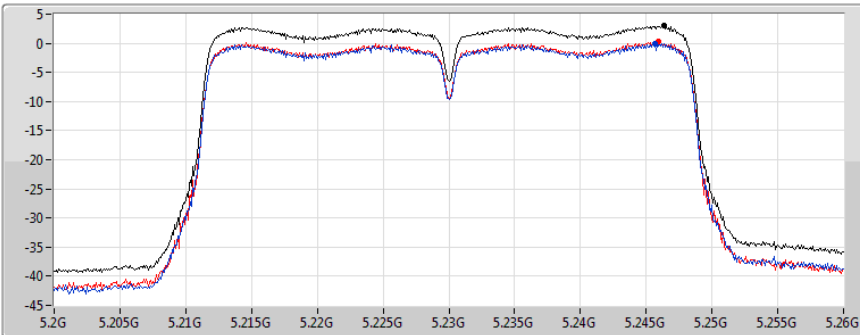

Sum
Port 1
Port 2

Sum	PD	Port 1	Port 2
(dBm/RBW)	(dBm/RBW)	(dBm/RBW)	(dBm/RBW)
2.95	2.95	-0.09	0.35

802.11ac VHT40_Nss1,(MCS0)_2TX

PSD

5270MHz

Ch Freq
5.27GHz
Span
60MHz
RBW
1MHz
VBW
3MHz
Sweep Time
1ms
Detector Type
RMS

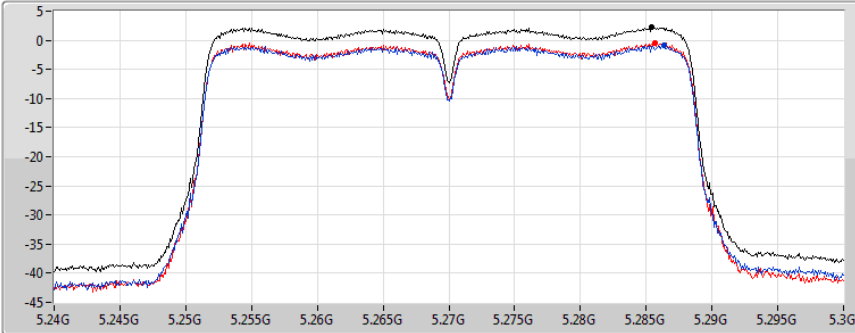

Sum
Port 1
Port 2

Sum	PD	Port 1	Port 2
(dBm/RBW)	(dBm/RBW)	(dBm/RBW)	(dBm/RBW)
2.20	2.20	-0.95	-0.43

802.11ac VHT40_Nss1,(MCS0)_2TX

PSD

5310MHz

Ch Freq
5.31GHz
Span
60MHz
RBW
1MHz
VBW
3MHz
Sweep Time
1ms
Detector Type
RMS

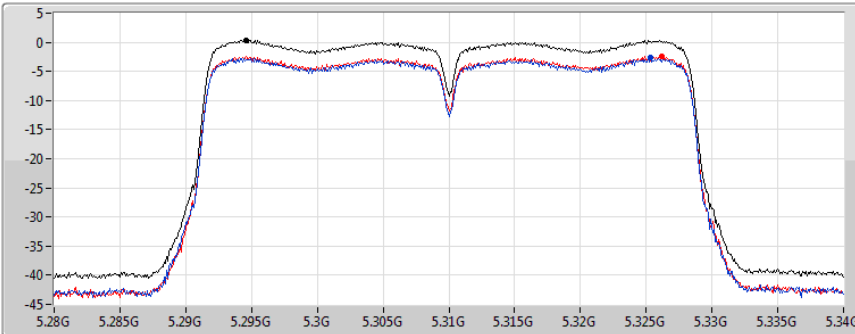

Sum
Port 1
Port 2

Sum	PD	Port 1	Port 2
(dBm/RBW)	(dBm/RBW)	(dBm/RBW)	(dBm/RBW)
0.32	0.32	-2.66	-2.36

802.11ac VHT40_Nss1,(MCS0)_2TX

PSD

5510MHz

Ch Freq
5.51GHz
Span
60MHz
RBW
1MHz
VBW
3MHz
Sweep Time
1ms
Detector Type
RMS

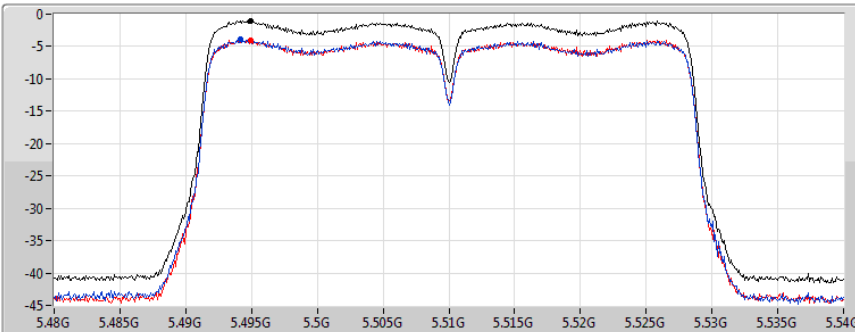

Sum
Port 1
Port 2

Sum	PD	Port 1	Port 2
(dBm/RBW)	(dBm/RBW)	(dBm/RBW)	(dBm/RBW)
-0.97	-0.97	-3.84	-4.07

802.11ac VHT40_Nss1,(MCS0)_2TX

PSD

5590MHz

Ch Freq
5.59GHz
Span
60MHz
RBW
1MHz
VBW
3MHz
Sweep Time
1ms
Detector Type
RMS

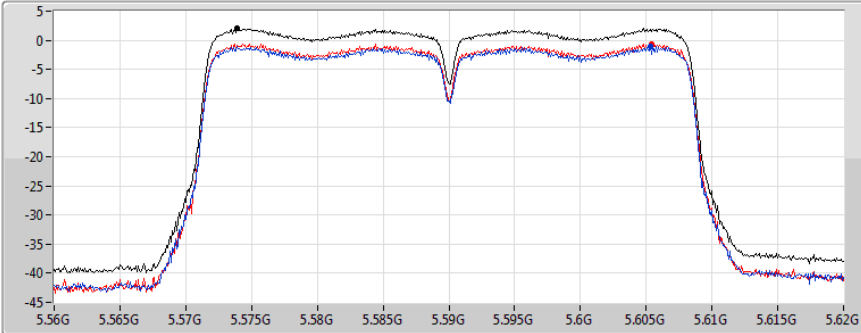

Sum
Port 1
Port 2

Sum	PD	Port 1	Port 2
(dBm/RBW)	(dBm/RBW)	(dBm/RBW)	(dBm/RBW)
2.05	2.05	-1.01	-0.66

802.11ac VHT40_Nss1,(MCS0)_2TX

PSD

5670MHz

Ch Freq
5.67GHz
Span
60MHz
RBW
1MHz
VBW
3MHz
Sweep Time
1ms
Detector Type
RMS

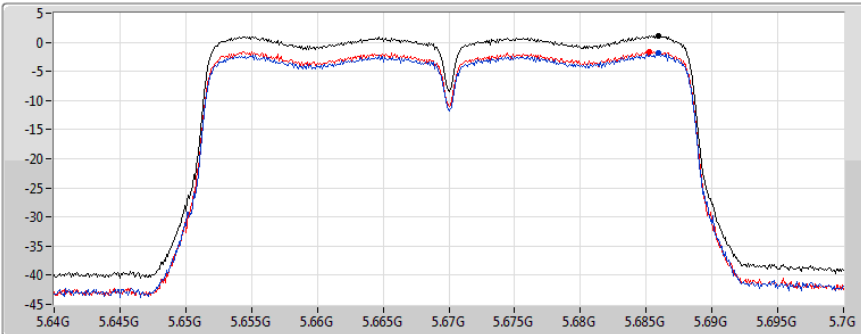

Sum
Port 1
Port 2

Sum	PD	Port 1	Port 2
(dBm/RBW)	(dBm/RBW)	(dBm/RBW)	(dBm/RBW)
1.17	1.17	-1.87	-1.58

802.11ac VHT40_Nss1,(MCS0)_2TX

PSD

5710MHz Straddle 5.47-5.725GHz

Ch Freq
5.69GHz
Span
140MHz
RBW
1MHz
VBW
3MHz
Sweep Time
1ms
Detector Type
RMS

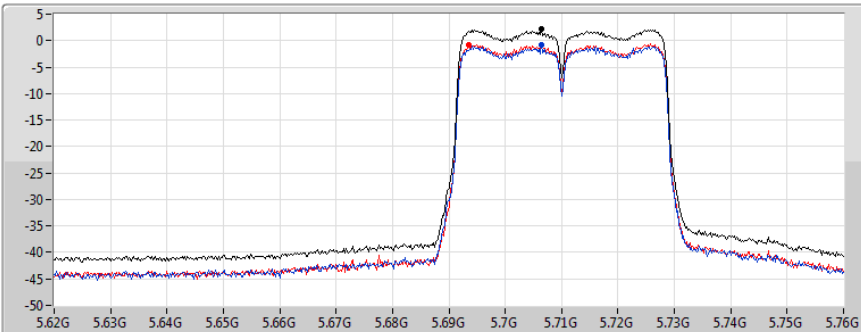

Sum
Port 1
Port 2

Sum	PD	Port 1	Port 2
(dBm/RBW)	(dBm/RBW)	(dBm/RBW)	(dBm/RBW)
2.10	2.10	-0.87	-0.81

802.11ac VHT40_Nss1,(MCS0)_2TX

PSD

5710MHz Straddle 5.725-5.85GHz

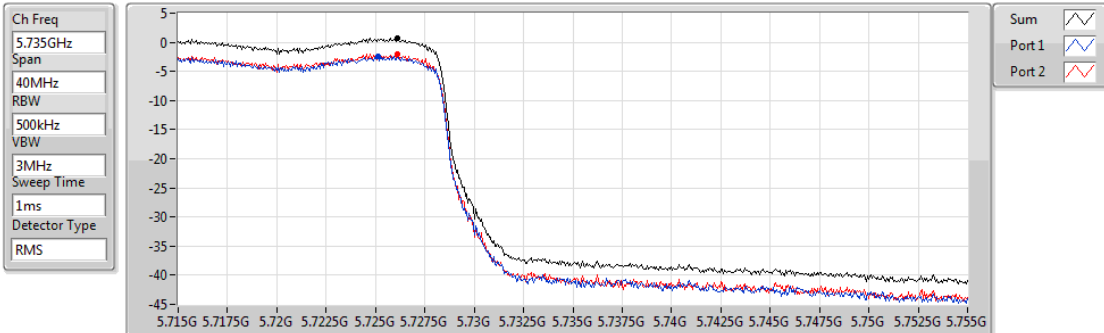

Sum	PD	Port 1	Port 2
(dBm/RBW)	(dBm/RBW)	(dBm/RBW)	(dBm/RBW)
0.68	0.68	-2.38	-2.02

802.11ac VHT40_Nss1,(MCS0)_2TX

PSD

5755MHz

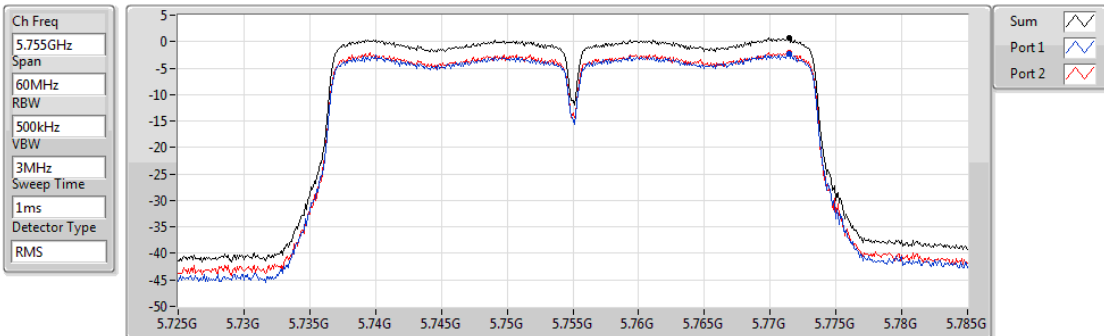

Sum	PD	Port 1	Port 2
(dBm/RBW)	(dBm/RBW)	(dBm/RBW)	(dBm/RBW)
0.76	0.76	-2.40	-2.11

802.11ac VHT40_Nss1,(MCS0)_2TX

PSD

5795MHz

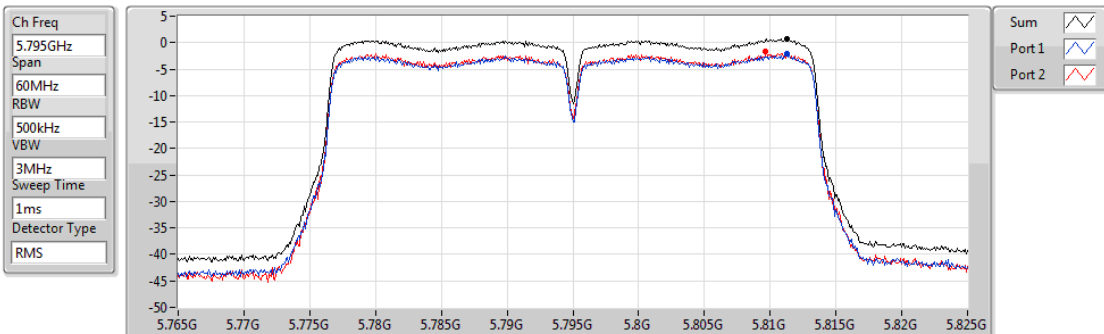

Sum	PD	Port 1	Port 2
(dBm/RBW)	(dBm/RBW)	(dBm/RBW)	(dBm/RBW)
0.80	0.80	-2.17	-1.75

802.11ac VHT80_Nss1,(MCS0)_2TX

PSD

5210MHz

Ch Freq
5.21GHz
Span
120MHz
RBW
1MHz
VBW
3MHz
Sweep Time
1ms
Detector Type
RMS

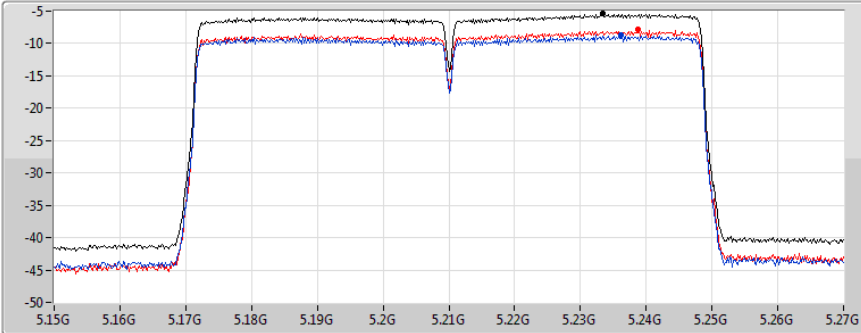

Sum
Port 1
Port 2

Sum	PD	Port 1	Port 2
(dBm/RBW)	(dBm/RBW)	(dBm/RBW)	(dBm/RBW)
-5.43	-5.43	-8.76	-7.82

802.11ac VHT80_Nss1,(MCS0)_2TX

PSD

5290MHz

Ch Freq
5.29GHz
Span
120MHz
RBW
1MHz
VBW
3MHz
Sweep Time
1ms
Detector Type
RMS

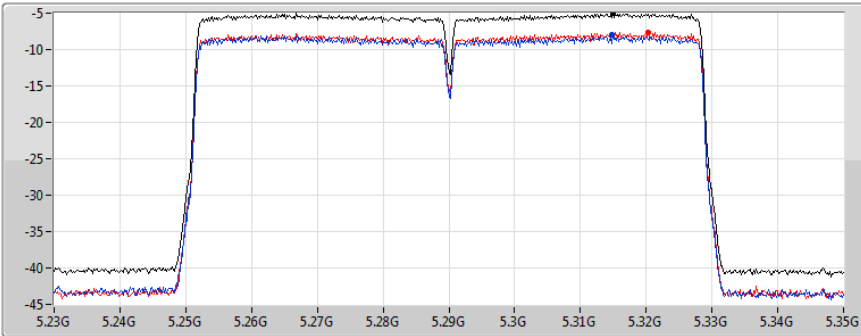

Sum
Port 1
Port 2

Sum	PD	Port 1	Port 2
(dBm/RBW)	(dBm/RBW)	(dBm/RBW)	(dBm/RBW)
-5.06	-5.06	-8.00	-7.69

802.11ac VHT80_Nss1,(MCS0)_2TX

PSD

5530MHz

Ch Freq
5.53GHz
Span
120MHz
RBW
1MHz
VBW
3MHz
Sweep Time
1ms
Detector Type
RMS

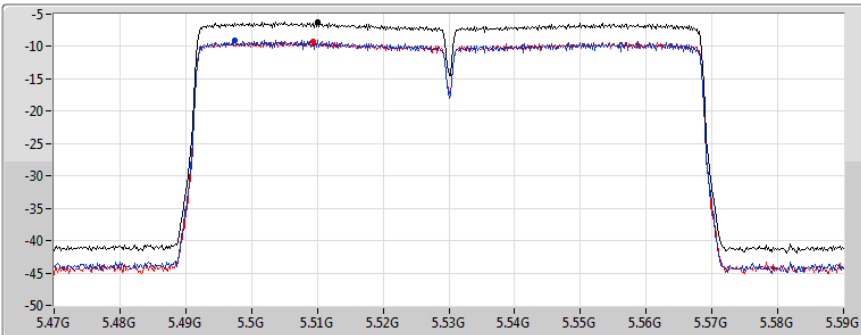

Sum
Port 1
Port 2

Sum	PD	Port 1	Port 2
(dBm/RBW)	(dBm/RBW)	(dBm/RBW)	(dBm/RBW)
-6.18	-6.18	-9.03	-9.19

802.11ac VHT80_Nss1,(MCS0)_2TX

PSD

5610MHz

Ch Freq
5.61GHz
Span
120MHz
RBW
1MHz
VBW
3MHz
Sweep Time
1ms
Detector Type
RMS

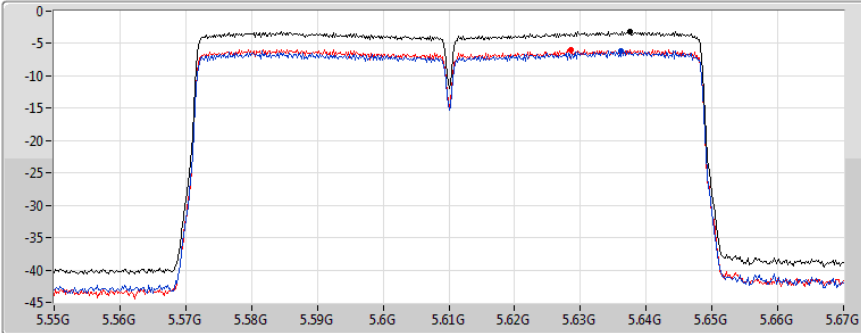

Sum
Port 1
Port 2

Sum	PD	Port 1	Port 2
(dBm/RBW)	(dBm/RBW)	(dBm/RBW)	(dBm/RBW)
-3.13	-3.13	-6.13	-5.94

802.11ac VHT80_Nss1,(MCS0)_2TX

PSD

5690MHz Straddle 5.47-5.725GHz

Ch Freq
5.65GHz
Span
300MHz
RBW
1MHz
VBW
3MHz
Sweep Time
1ms
Detector Type
RMS

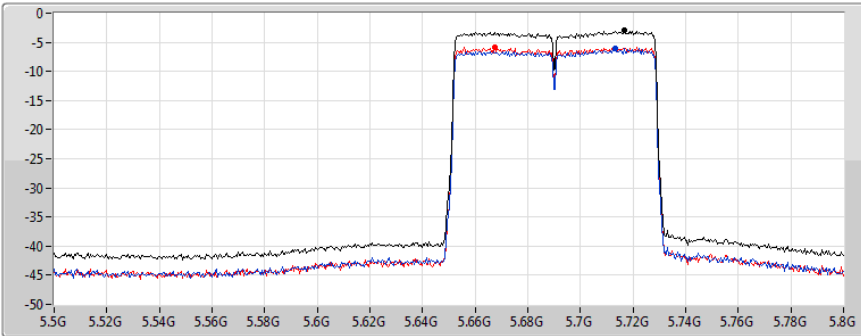

Sum
Port 1
Port 2

Sum	PD	Port 1	Port 2
(dBm/RBW)	(dBm/RBW)	(dBm/RBW)	(dBm/RBW)
-3.01	-3.01	-6.00	-5.80

802.11ac VHT80_Nss1,(MCS0)_2TX

PSD

5690MHz Straddle 5.725-5.85GHz

Ch Freq
5.735GHz
Span
40MHz
RBW
500kHz
VBW
3MHz
Sweep Time
1ms
Detector Type
RMS

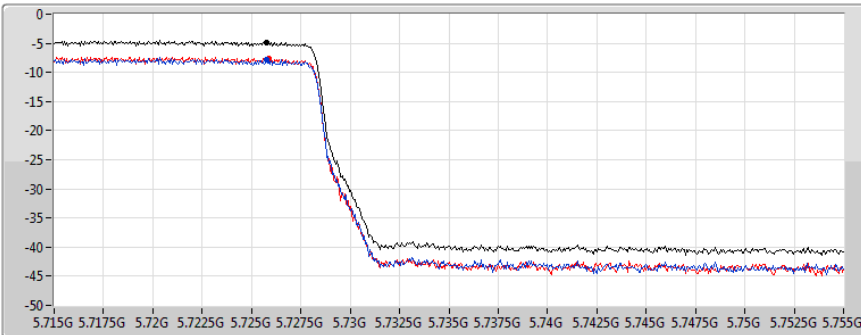

Sum
Port 1
Port 2

Sum	PD	Port 1	Port 2
(dBm/RBW)	(dBm/RBW)	(dBm/RBW)	(dBm/RBW)
-4.83	-4.83	-7.86	-7.61

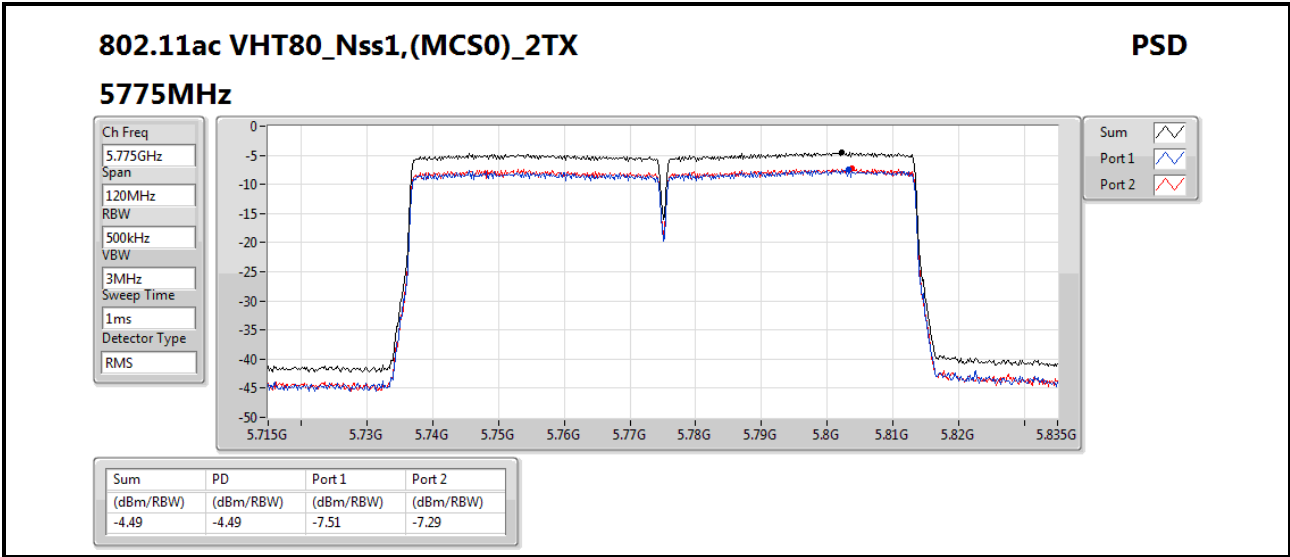

3.5 Transmitter Radiated and Band Edge Emissions

3.5.1 Limit of Transmitter Radiated and Band Edge Emissions

Restricted Band Emissions Limit			
Frequency Range (MHz)	Field Strength (uV/m)	Field Strength (dBuV/m)	Measure Distance (m)
0.009~0.490	2400/F(kHz)	48.5 - 13.8	300
0.490~1.705	24000/F(kHz)	33.8 - 23	30
1.705~30.0	30	29	30
30~88	100	40	3
88~216	150	43.5	3
216~960	200	46	3
Above 960	500	54	3

Note 1:
Qusai-Peak value is measured for frequency below 1GHz except for 9–90 kHz, 110–490 kHz frequency band. Peak and average value are measured for frequency above 1GHz. The limit on average radio frequency emission is as above table. The limit on peak radio frequency emissions is 20 dB above the maximum permitted average emission limit

Note 2:
Measurements may be performed at a distance other than what is specified provided. When performing measurements at a distance other than that specified, the results shall be extrapolated to the specified distance using an extrapolation factor as below, Frequency at or above 30 MHz: 20 dB/decade Frequency below 30 MHz: 40 dB/decade.

Un-restricted band emissions above 1GHz Limit	
Operating Band	Limit
5.15 - 5.25 GHz	e.i.r.p. -27 dBm [68.2 dBuV/m@3m]
5.25 - 5.35 GHz	e.i.r.p. -27 dBm [68.2 dBuV/m@3m]
5.47 - 5.725 GHz	e.i.r.p. -27 dBm [68.2 dBuV/m@3m]
5.725 - 5.850 GHz	All emissions shall be limited to a level of -27 dBm/MHz at 75 MHz or more above or below the band edge increasing linearly to 10 dBm/MHz at 25 MHz above or below the band edge, and from 25 MHz above or below the band edge increasing linearly to a level of 15.6 dBm/MHz at 5 MHz above or below the band edge, and from 5 MHz above or below the band edge increasing linearly to a level of 27 dBm/MHz at the band edge.

Note 1: Measurements may be performed at a distance other than the limit distance provided they are not performed in the near field and the emissions to be measured can be detected by the measurement equipment. When performing measurements at a distance other than that specified, the results shall be extrapolated to the specified distance using an extrapolation factor of 20 dB/decade (inverse of linear distance for field-strength measurements, inverse of linear distance-squared for power-density measurements).

3.5.2 Test Procedures

1. Measurement is made at a semi-anechoic chamber that incorporates a turntable allowing a EUT rotation of 360°. A continuously-rotating, remotely-controlled turntable is installed at the test site to support the EUT and facilitate determination of the direction of maximum radiation for each EUT emission frequency. The EUT is placed at test table. For emissions testing at or below 1 GHz, the table height is 80 cm above the reference ground plane. For emission measurements above 1 GHz, the table height is 1.5 m
2. Measurement is made with the antenna positioned in both the horizontal and vertical planes of polarization. The measurement antenna is varied in height (1m ~ 4m) above the reference ground plane to obtain the maximum signal strength. Distance between EUT and antenna is 3 m.
3. This investigation is performed with the EUT rotated 360°, the antenna height scanned between 1 m and 4 m, and the antenna rotated to repeat the measurements for both the horizontal and vertical antenna polarizations.

Note:

1. 120kHz measurement bandwidth of test receiver and Quasi-peak detector is for radiated emission below 1GHz.
2. RBW=1MHz, VBW=3MHz and Peak detector is for peak measured value of radiated emission above 1GHz.
3. RBW=1MHz, VBW=1/T and Peak detector is for average measured value of radiated emission above 1GHz.

3.5.3 Test Setup

Radiated Emissions below 1 GHz

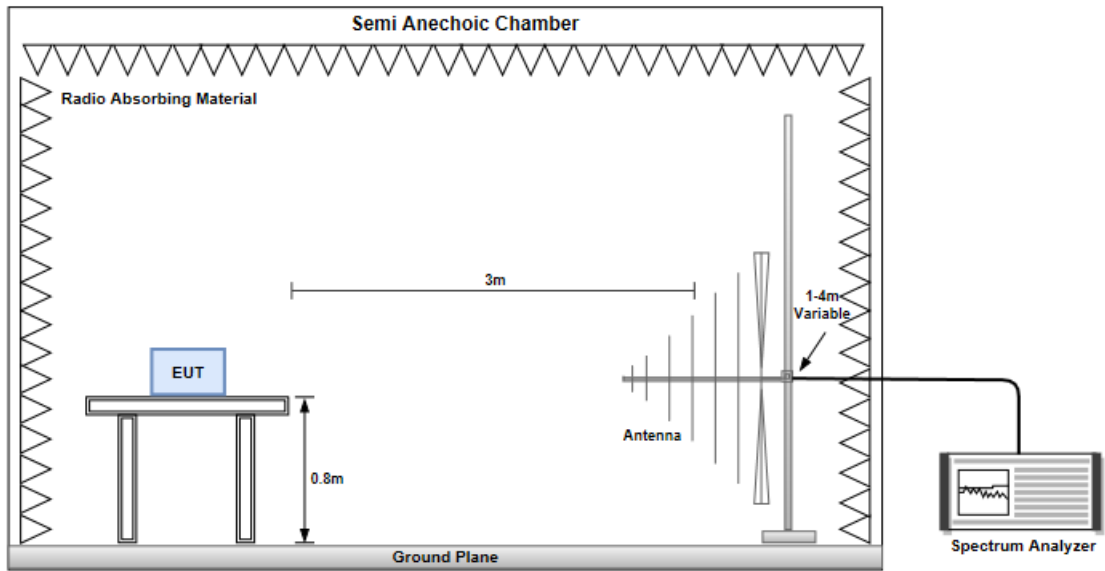

Radiated Emissions above 1 GHz

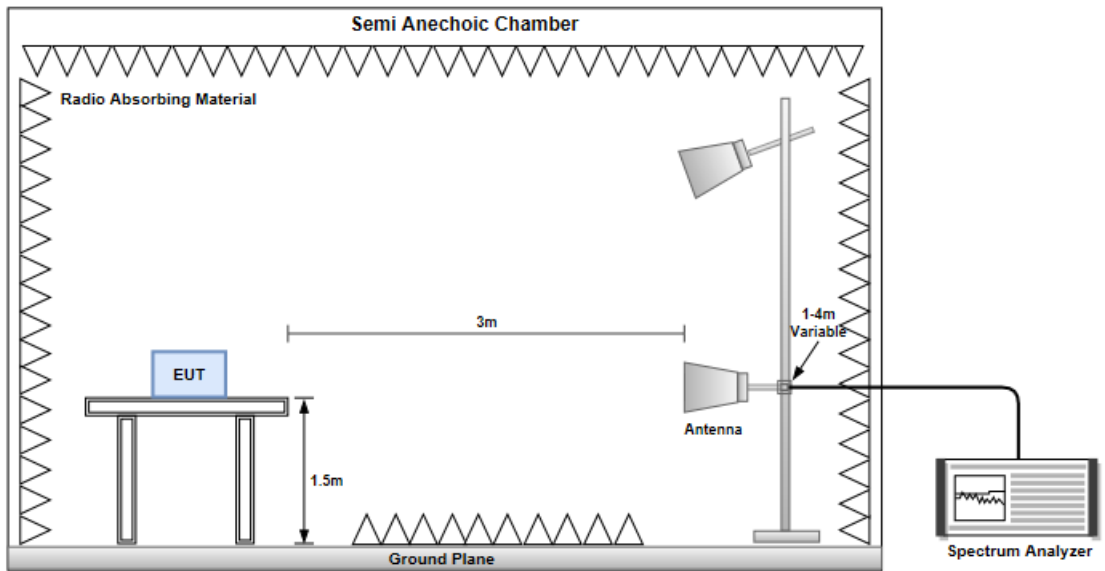

Test Configuration 1

3.5.4 Transmitter Radiated Unwanted Emissions (Below 1GHz)

Modulation	VHT20	Test Freq. (MHz)	5240
Polarization	Horizontal		

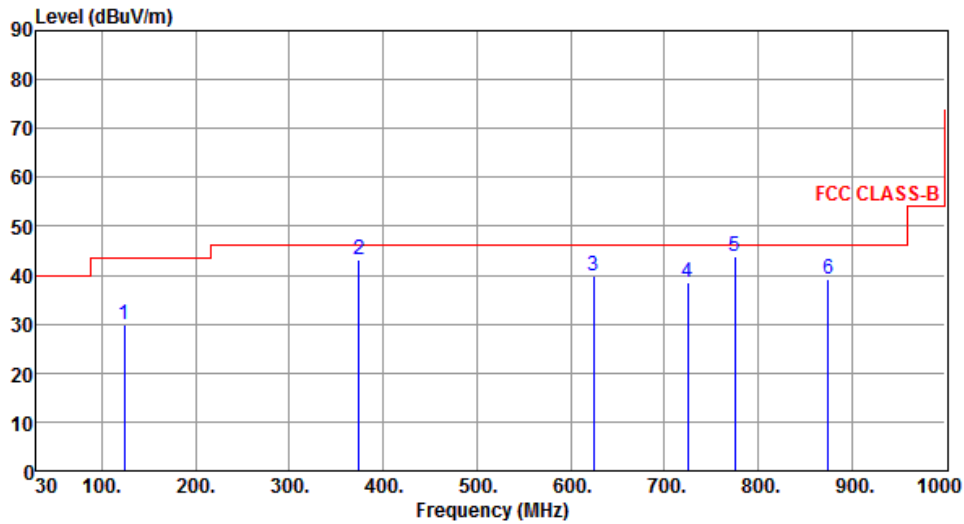

	Freq. MHz	Emission level dBuV/m	Limit dBuV/m	Margin dB	SA reading dBuV	Factor dB	Remark	ANT High cm	Turn Table deg
1	124.09	29.90	43.50	-13.60	40.16	-10.26	Peak	---	---
2	374.35	43.31	46.00	-2.69	49.27	-5.96	QP	100	266
3	624.61	39.77	46.00	-6.23	40.22	-0.45	Peak	---	---
4	725.49	38.41	46.00	-7.59	37.14	1.27	Peak	---	---
5	774.99	43.87	46.00	-2.13	41.82	2.05	QP	100	145
6	874.87	39.08	46.00	-6.92	35.73	3.35	Peak	---	---

Note 1: Emission Level (dBuV/m) = SA Reading (dBuV/m) + Factor* (dB)

*Factor includes antenna factor, cable loss and amplifier gain

Note 2: Margin (dB) = Emission level (dBuV/m) – Limit (dBuV/m).

Note 3: All spurious emissions below 30MHz are more than 20 dB below the limit.

Modulation	VHT20	Test Freq. (MHz)	5240
Polarization	Vertical		

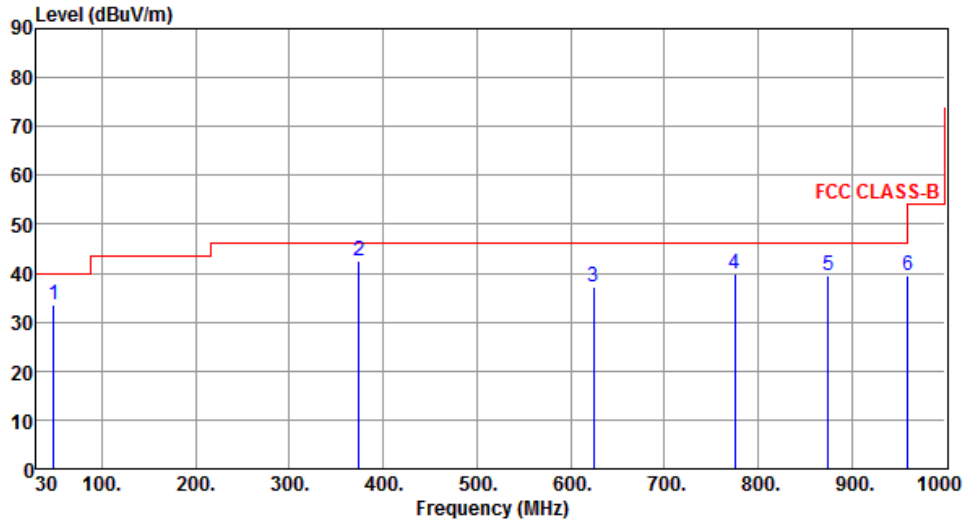

	Freq. MHz	Emission level dBuV/m	Limit dBuV/m	Margin dB	SA reading dBuV	Factor dB	Remark	ANT High cm	Turn Table deg
1	48.43	33.55	40.00	-6.45	41.58	-8.03	Peak	---	---
2	374.35	42.65	46.00	-3.35	48.61	-5.96	QP	119	178
3	624.61	37.03	46.00	-8.97	37.48	-0.45	Peak	---	---
4	774.96	39.80	46.00	-6.20	37.75	2.05	Peak	---	---
5	874.87	39.56	46.00	-6.44	36.21	3.35	Peak	---	---
6	960.23	39.44	54.00	-14.56	34.65	4.79	Peak	---	---

Note 1: Emission Level (dBuV/m) = SA Reading (dBuV/m) + Factor* (dB)

*Factor includes antenna factor , cable loss and amplifier gain

Note 2: Margin (dB) = Emission level (dBuV/m) – Limit (dBuV/m).

Note 3: All spurious emissions below 30MHz are more than 20 dB below the limit.

Modulation	VHT20	Test Freq. (MHz)	5745
Polarization	Horizontal		

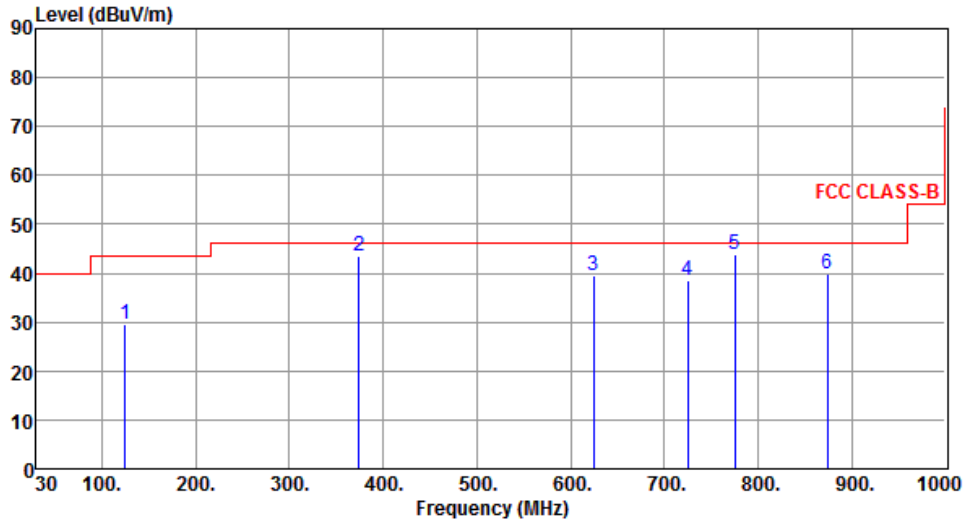

	Freq. MHz	Emission level dBuV/m	Limit dBuV/m	Margin dB	SA reading dBuV	Factor dB	Remark	ANT High cm	Turn Table deg
1	125.00	29.58	43.50	-13.92	39.73	-10.15	Peak	---	---
2	374.54	43.57	46.00	-2.43	49.52	-5.95	QP	100	265
3	624.80	39.44	46.00	-6.56	39.89	-0.45	Peak	---	---
4	725.11	38.40	46.00	-7.60	37.14	1.26	Peak	---	---
5	775.00	43.86	46.00	-2.14	41.80	2.06	QP	100	146
6	874.44	39.74	46.00	-6.26	36.39	3.35	Peak	---	---

Note 1: Emission Level (dBuV/m) = SA Reading (dBuV/m) + Factor* (dB)

*Factor includes antenna factor , cable loss and amplifier gain

Note 2: Margin (dB) = Emission level (dBuV/m) – Limit (dBuV/m).

Note 3: All spurious emissions below 30MHz are more than 20 dB below the limit.

Modulation	VHT20	Test Freq. (MHz)	5745
Polarization	Vertical		

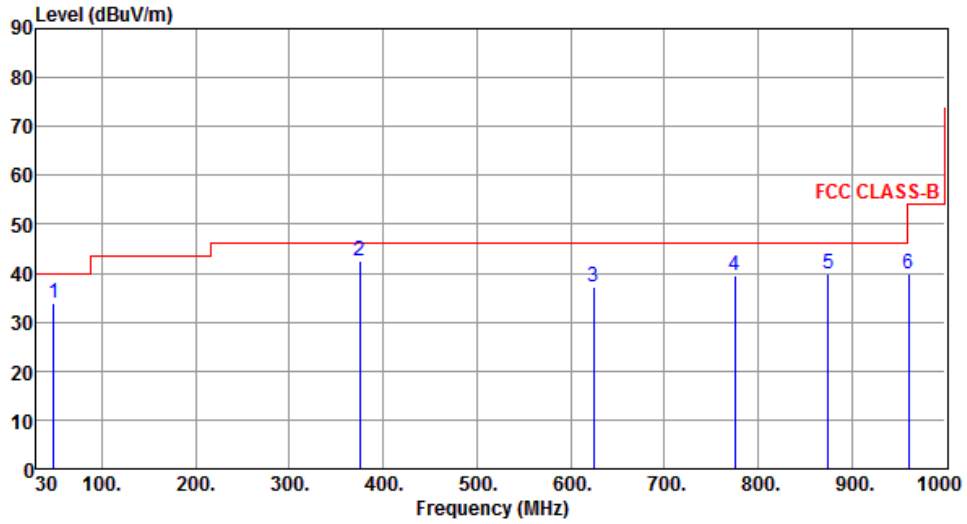

	Freq. MHz	Emission level dBuV/m	Limit dBuV/m	Margin dB	SA reading dBuV	Factor dB	Remark	ANT High cm	Turn Table deg
1	48.85	33.87	40.00	-6.13	41.87	-8.00	Peak	---	---
2	375.00	42.54	46.00	-3.46	48.47	-5.93	QP	120	178
3	624.44	37.34	46.00	-8.66	37.79	-0.45	Peak	---	---
4	775.32	39.56	46.00	-6.44	37.50	2.06	Peak	---	---
5	875.00	39.84	46.00	-6.16	36.50	3.34	Peak	---	---
6	960.35	39.94	54.00	-14.06	35.15	4.79	Peak	---	---

Note 1: Emission Level (dBuV/m) = SA Reading (dBuV/m) + Factor* (dB)

*Factor includes antenna factor , cable loss and amplifier gain

Note 2: Margin (dB) = Emission level (dBuV/m) – Limit (dBuV/m).

Note 3: All spurious emissions below 30MHz are more than 20 dB below the limit.

3.5.5 Transmitter Radiated Unwanted Emissions (Above 1GHz) for 11a

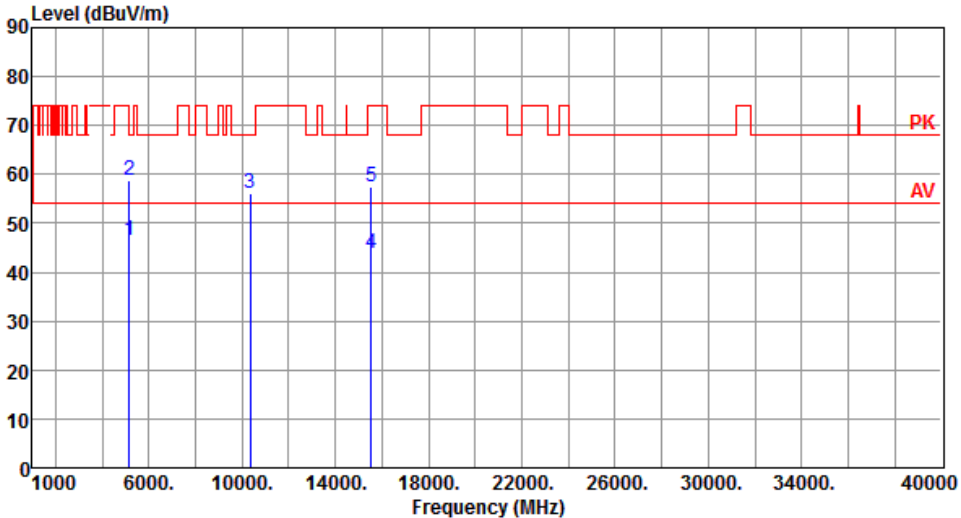
Modulation	11a	Test Freq. (MHz)	5180																																																																		
Polarization	Horizontal																																																																				
																																																																					
	<table border="1"> <thead> <tr> <th>Freq.</th> <th>Emission level</th> <th>Limit</th> <th>Margin</th> <th>SA reading</th> <th>Factor</th> <th>Remark</th> <th>ANT High</th> <th>Turn Table</th> </tr> <tr> <th>MHz</th> <th>dBuV/m</th> <th>dBuV/m</th> <th>dB</th> <th>dBuV</th> <th>dB</th> <th></th> <th>cm</th> <th>deg</th> </tr> </thead> <tbody> <tr> <td>1</td> <td>5150.00</td> <td>46.54</td> <td>54.00</td> <td>-7.46</td> <td>42.30</td> <td>4.24</td> <td>Average</td> <td>193</td> <td>124</td> </tr> <tr> <td>2</td> <td>5150.00</td> <td>58.93</td> <td>74.00</td> <td>-15.07</td> <td>54.69</td> <td>4.24</td> <td>Peak</td> <td>193</td> <td>124</td> </tr> <tr> <td>3</td> <td>10360.00</td> <td>56.10</td> <td>68.20</td> <td>-12.10</td> <td>42.41</td> <td>13.69</td> <td>Peak</td> <td>100</td> <td>114</td> </tr> <tr> <td>4</td> <td>15540.00</td> <td>43.93</td> <td>54.00</td> <td>-10.07</td> <td>29.24</td> <td>14.69</td> <td>Average</td> <td>100</td> <td>108</td> </tr> <tr> <td>5</td> <td>15540.00</td> <td>57.49</td> <td>74.00</td> <td>-16.51</td> <td>42.80</td> <td>14.69</td> <td>Peak</td> <td>100</td> <td>108</td> </tr> </tbody> </table>	Freq.	Emission level	Limit	Margin	SA reading	Factor	Remark	ANT High	Turn Table	MHz	dBuV/m	dBuV/m	dB	dBuV	dB		cm	deg	1	5150.00	46.54	54.00	-7.46	42.30	4.24	Average	193	124	2	5150.00	58.93	74.00	-15.07	54.69	4.24	Peak	193	124	3	10360.00	56.10	68.20	-12.10	42.41	13.69	Peak	100	114	4	15540.00	43.93	54.00	-10.07	29.24	14.69	Average	100	108	5	15540.00	57.49	74.00	-16.51	42.80	14.69	Peak	100	108
Freq.	Emission level	Limit	Margin	SA reading	Factor	Remark	ANT High	Turn Table																																																													
MHz	dBuV/m	dBuV/m	dB	dBuV	dB		cm	deg																																																													
1	5150.00	46.54	54.00	-7.46	42.30	4.24	Average	193	124																																																												
2	5150.00	58.93	74.00	-15.07	54.69	4.24	Peak	193	124																																																												
3	10360.00	56.10	68.20	-12.10	42.41	13.69	Peak	100	114																																																												
4	15540.00	43.93	54.00	-10.07	29.24	14.69	Average	100	108																																																												
5	15540.00	57.49	74.00	-16.51	42.80	14.69	Peak	100	108																																																												
<p>Note 1: Emission Level (dBuV/m) = SA Reading (dBuV/m) + Factor* (dB) *Factor includes antenna factor , cable loss and amplifier gain Note 2: Margin (dB) = Emission level (dBuV/m) – Limit (dBuV/m).</p>																																																																					

Modulation	11a	Test Freq. (MHz)	5180
Polarization	Vertical		

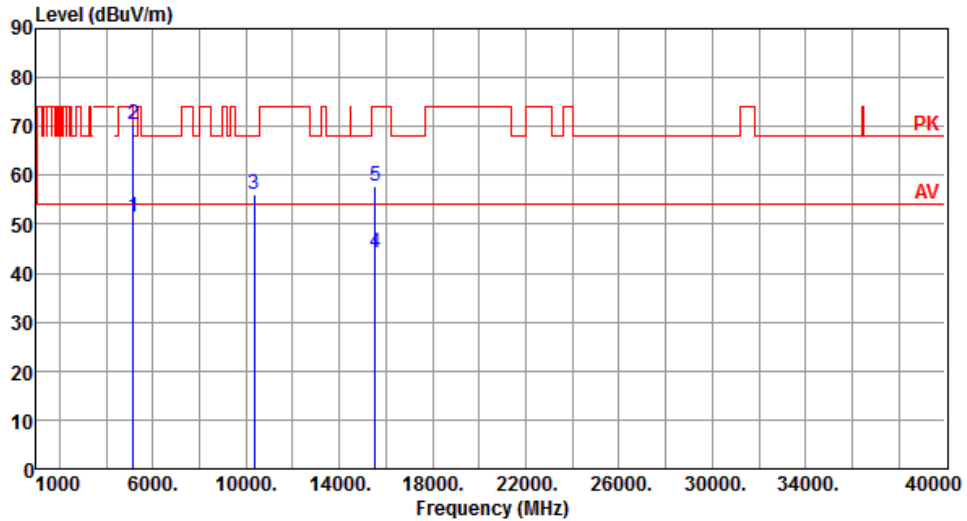

	Freq. MHz	Emission level dBuV/m	Limit dBuV/m	Margin dB	SA reading dBuV	Factor dB	Remark	ANT High cm	Turn Table deg
1	5150.00	51.38	54.00	-2.62	47.14	4.24	Average	184	343
2	5150.00	70.25	74.00	-3.75	66.01	4.24	Peak	184	343
3	10360.00	56.16	68.20	-12.04	42.47	13.69	Peak	100	154
4	15540.00	44.26	54.00	-9.74	29.57	14.69	Average	100	147
5	15540.00	57.79	74.00	-16.21	43.10	14.69	Peak	100	147

Note 1: Emission Level (dBuV/m) = SA Reading (dBuV/m) + Factor* (dB)

*Factor includes antenna factor , cable loss and amplifier gain

Note 2: Margin (dB) = Emission level (dBuV/m) – Limit (dBuV/m).

Modulation	11a	Test Freq. (MHz)	5200
Polarization	Horizontal		

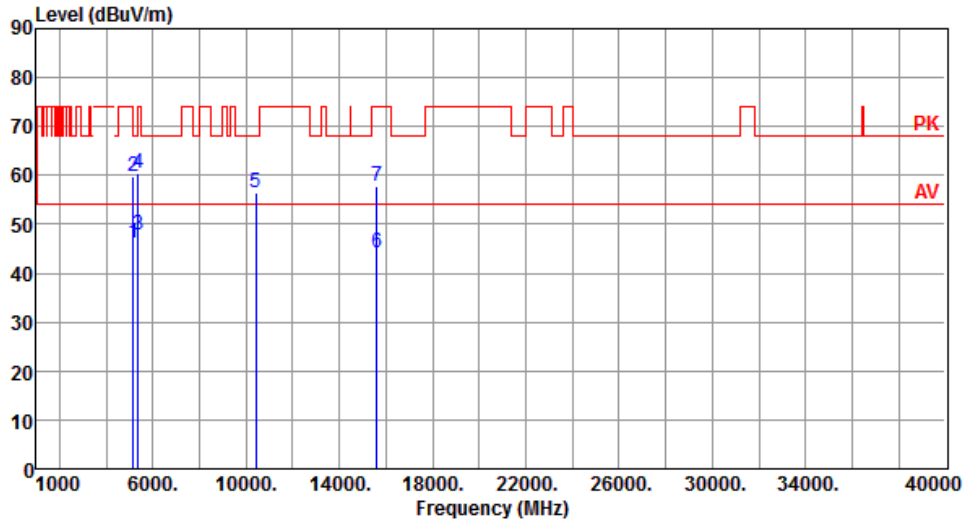

	Freq. MHz	Emission level dBuV/m	Limit dBuV/m	Margin dB	SA reading dBuV	Factor dB	Remark	ANT High cm	Turn Table deg
1	5150.00	46.24	54.00	-7.76	42.00	4.24	Average	193	124
2	5150.00	59.93	74.00	-14.07	55.69	4.24	Peak	193	124
3	5350.00	47.97	54.00	-6.03	43.54	4.43	Average	193	124
4	5350.00	60.33	74.00	-13.67	55.90	4.43	Peak	193	124
5	10400.00	56.40	68.20	-11.80	42.69	13.71	Peak	100	125
6	15600.00	44.22	54.00	-9.78	29.57	14.65	Average	100	115
7	15600.00	57.79	74.00	-16.21	43.14	14.65	Peak	100	115

Note 1: Emission Level (dBuV/m) = SA Reading (dBuV/m) + Factor* (dB)

*Factor includes antenna factor , cable loss and amplifier gain

Note 2: Margin (dB) = Emission level (dBuV/m) – Limit (dBuV/m).

Modulation	11a	Test Freq. (MHz)	5200
Polarization	Vertical		

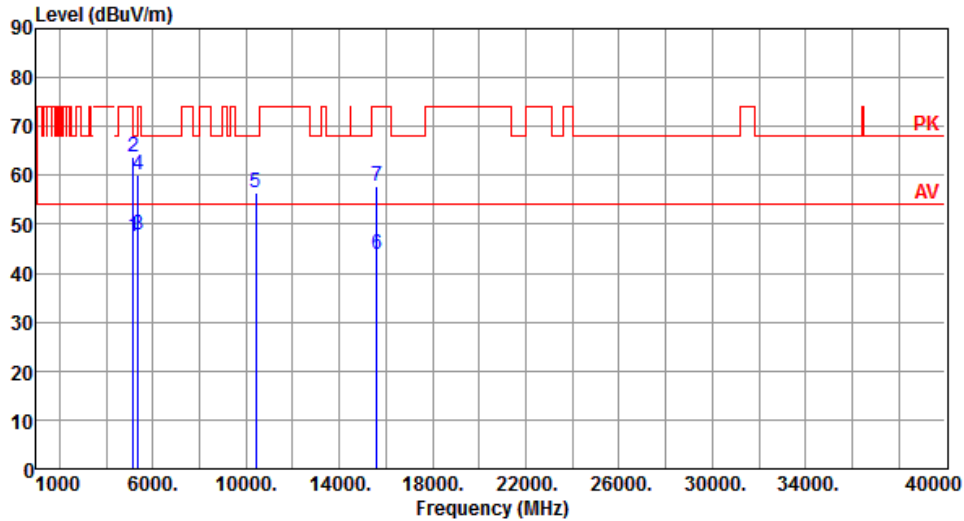

	Freq. MHz	Emission level dBuV/m	Limit dBuV/m	Margin dB	SA reading dBuV	Factor dB	Remark	ANT High cm	Turn Table deg
1	5150.00	47.57	54.00	-6.43	43.33	4.24	Average	162	143
2	5150.00	63.75	74.00	-10.25	59.51	4.24	Peak	162	143
3	5350.00	47.67	54.00	-6.33	43.24	4.43	Average	162	143
4	5350.00	60.06	74.00	-13.94	55.63	4.43	Peak	162	143
5	10400.00	56.45	68.20	-11.75	42.74	13.71	Peak	100	151
6	15600.00	43.89	54.00	-10.11	29.24	14.65	Average	100	150
7	15600.00	57.85	74.00	-16.15	43.20	14.65	Peak	100	150

Note 1: Emission Level (dBuV/m) = SA Reading (dBuV/m) + Factor* (dB)

*Factor includes antenna factor , cable loss and amplifier gain

Note 2: Margin (dB) = Emission level (dBuV/m) – Limit (dBuV/m).

Modulation	11a	Test Freq. (MHz)	5240
Polarization	Horizontal		

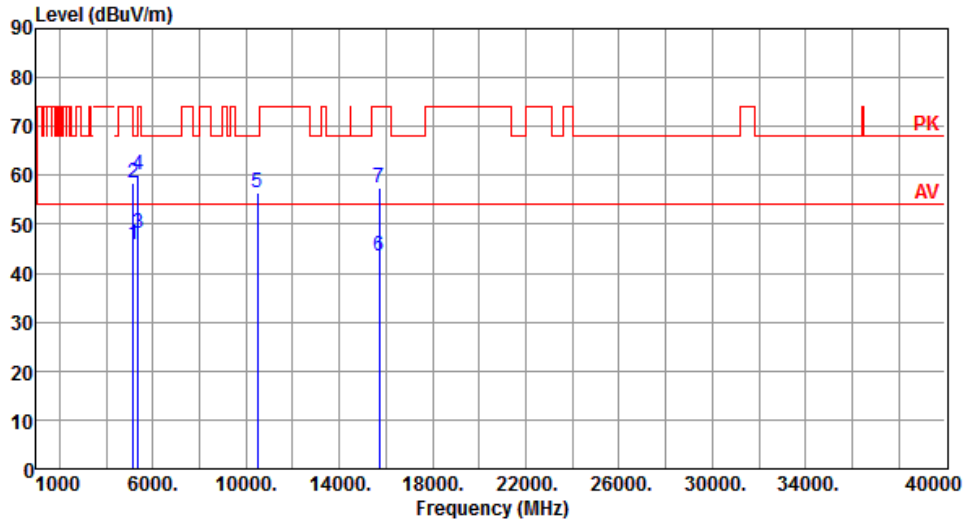

	Freq. MHz	Emission level dBuV/m	Limit dBuV/m	Margin dB	SA reading dBuV	Factor dB	Remark	ANT High cm	Turn Table deg
1	5150.00	45.88	54.00	-8.12	41.64	4.24	Average	188	121
2	5150.00	58.47	74.00	-15.53	54.23	4.24	Peak	188	121
3	5350.00	47.99	54.00	-6.01	43.56	4.43	Average	188	121
4	5350.00	60.03	74.00	-13.97	55.60	4.43	Peak	188	121
5	10480.00	56.41	68.20	-11.79	42.67	13.74	Peak	1000	110
6	15720.00	43.49	54.00	-10.51	28.91	14.58	Average	1000	105
7	15720.00	57.58	74.00	-16.42	43.00	14.58	Peak	1000	105

Note 1: Emission Level (dBuV/m) = SA Reading (dBuV/m) + Factor* (dB)

*Factor includes antenna factor , cable loss and amplifier gain

Note 2: Margin (dB) = Emission level (dBuV/m) – Limit (dBuV/m).

Modulation	11a	Test Freq. (MHz)	5240
Polarization	Vertical		

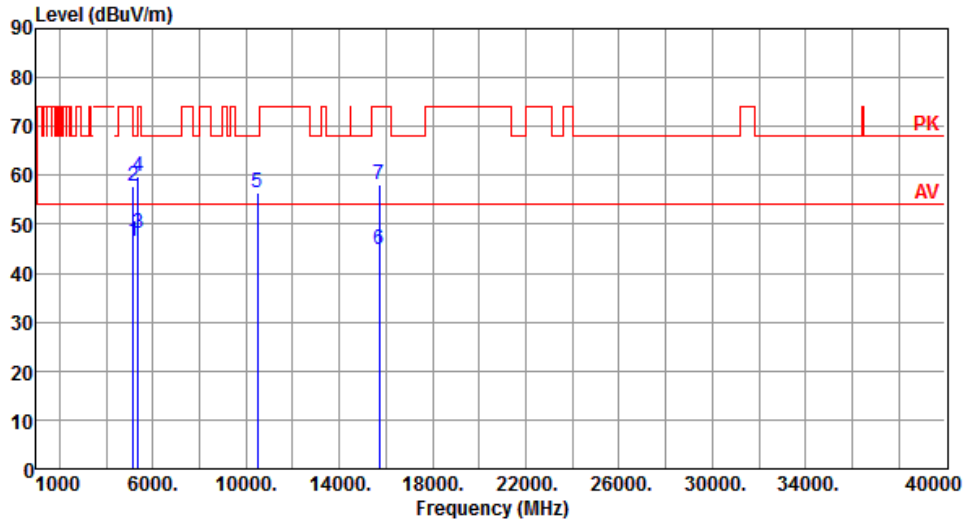

	Freq. MHz	Emission level dBuV/m	Limit dBuV/m	Margin dB	SA reading dBuV	Factor dB	Remark	ANT High cm	Turn Table deg
1	5150.00	46.60	54.00	-7.40	42.36	4.24	Average	207	143
2	5150.00	57.78	74.00	-16.22	53.54	4.24	Peak	207	143
3	5350.00	47.99	54.00	-6.01	43.56	4.43	Average	207	143
4	5350.00	59.90	74.00	-14.10	55.47	4.43	Peak	207	143
5	10480.00	56.31	68.20	-11.89	42.57	13.74	Peak	100	150
6	15720.00	44.79	54.00	-9.21	30.21	14.58	Average	100	155
7	15720.00	58.18	74.00	-15.82	43.60	14.58	Peak	100	155

Note 1: Emission Level (dBuV/m) = SA Reading (dBuV/m) + Factor* (dB)

*Factor includes antenna factor , cable loss and amplifier gain

Note 2: Margin (dB) = Emission level (dBuV/m) – Limit (dBuV/m).

Modulation	11a	Test Freq. (MHz)	5260
Polarization	Horizontal		

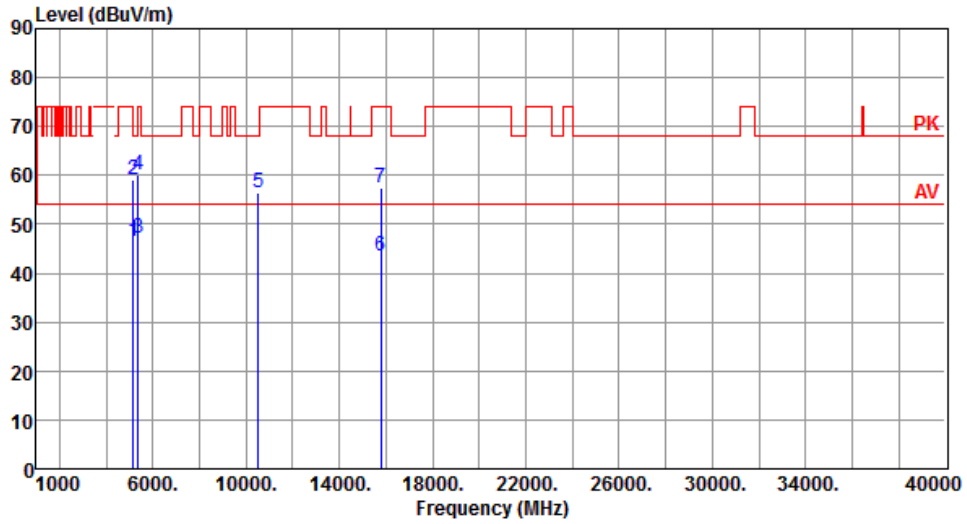

	Freq. MHz	Emission level dBuV/m	Limit dBuV/m	Margin dB	SA reading dBuV	Factor dB	Remark	ANT High cm	Turn Table deg
1	5150.00	46.34	54.00	-7.66	42.10	4.24	Average	191	88
2	5150.00	59.11	74.00	-14.89	54.87	4.24	Peak	191	88
3	5350.00	47.10	54.00	-6.90	42.67	4.43	Average	191	88
4	5350.00	60.06	74.00	-13.94	55.63	4.43	Peak	191	88
5	10520.00	56.46	68.20	-11.74	42.69	13.77	Peak	100	90
6	15780.00	43.55	54.00	-10.45	29.00	14.55	Average	100	95
7	15780.00	57.55	74.00	-16.45	43.00	14.55	Peak	100	95

Note 1: Emission Level (dBuV/m) = SA Reading (dBuV/m) + Factor* (dB)

*Factor includes antenna factor , cable loss and amplifier gain

Note 2: Margin (dB) = Emission level (dBuV/m) – Limit (dBuV/m).

Modulation	11a	Test Freq. (MHz)	5260
Polarization	Vertical		

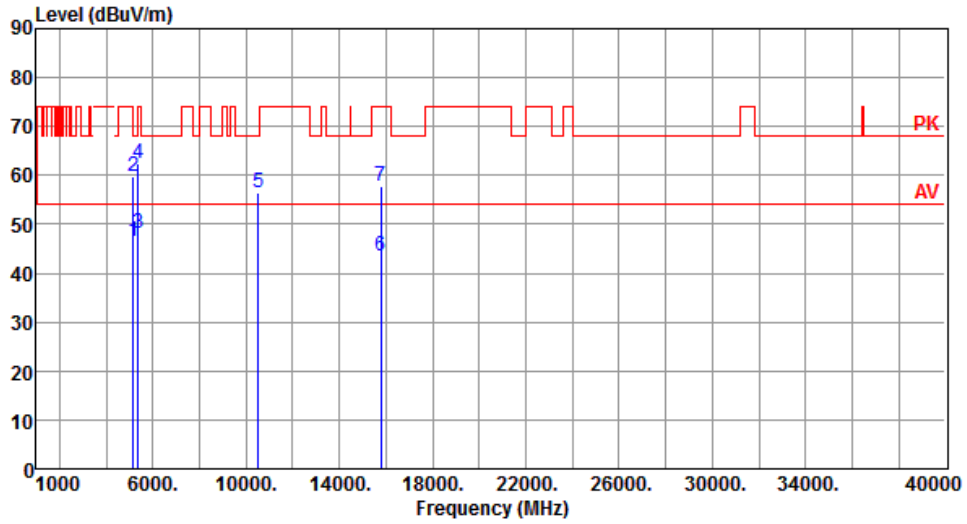

	Freq. MHz	Emission level dBuV/m	Limit dBuV/m	Margin dB	SA reading dBuV	Factor dB	Remark	ANT High cm	Turn Table deg
1	5150.00	46.38	54.00	-7.62	42.14	4.24	Average	176	138
2	5150.00	59.65	74.00	-14.35	55.41	4.24	Peak	176	138
3	5350.00	48.03	54.00	-5.97	43.60	4.43	Average	176	138
4	5350.00	62.40	74.00	-11.60	57.97	4.43	Peak	176	138
5	10520.00	56.43	68.20	-11.77	42.66	13.77	Peak	100	142
6	15780.00	43.54	54.00	-10.46	28.99	14.55	Average	100	145
7	15780.00	57.75	74.00	-16.25	43.20	14.55	Peak	100	145

Note 1: Emission Level (dBuV/m) = SA Reading (dBuV/m) + Factor* (dB)

*Factor includes antenna factor , cable loss and amplifier gain

Note 2: Margin (dB) = Emission level (dBuV/m) – Limit (dBuV/m).

Modulation	11a	Test Freq. (MHz)	5300
Polarization	Horizontal		

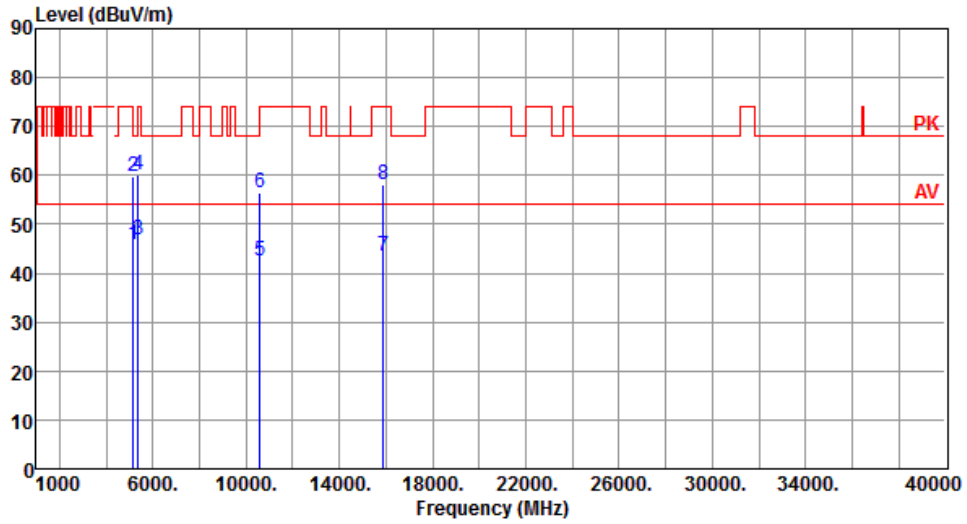

	Freq. MHz	Emission level dBuV/m	Limit dBuV/m	Margin dB	SA reading dBuV	Factor dB	Remark	ANT High cm	Turn Table deg
1	5150.00	45.80	54.00	-8.20	41.56	4.24	Average	179	92
2	5150.00	59.65	74.00	-14.35	55.41	4.24	Peak	179	92
3	5350.00	46.76	54.00	-7.24	42.33	4.43	Average	179	92
4	5350.00	60.10	74.00	-13.90	55.67	4.43	Peak	179	92
5	10600.00	42.56	54.00	-11.44	28.69	13.87	Average	100	99
6	10600.00	56.56	74.00	-17.44	42.69	13.87	Peak	100	99
7	15900.00	43.62	54.00	-10.38	29.14	14.48	Average	100	102
8	15900.00	58.26	74.00	-15.74	43.78	14.48	Peak	100	102

Note 1: Emission Level (dBuV/m) = SA Reading (dBuV/m) + Factor* (dB)

*Factor includes antenna factor , cable loss and amplifier gain

Note 2: Margin (dB) = Emission level (dBuV/m) – Limit (dBuV/m).

Modulation	11a	Test Freq. (MHz)	5300
Polarization	Vertical		

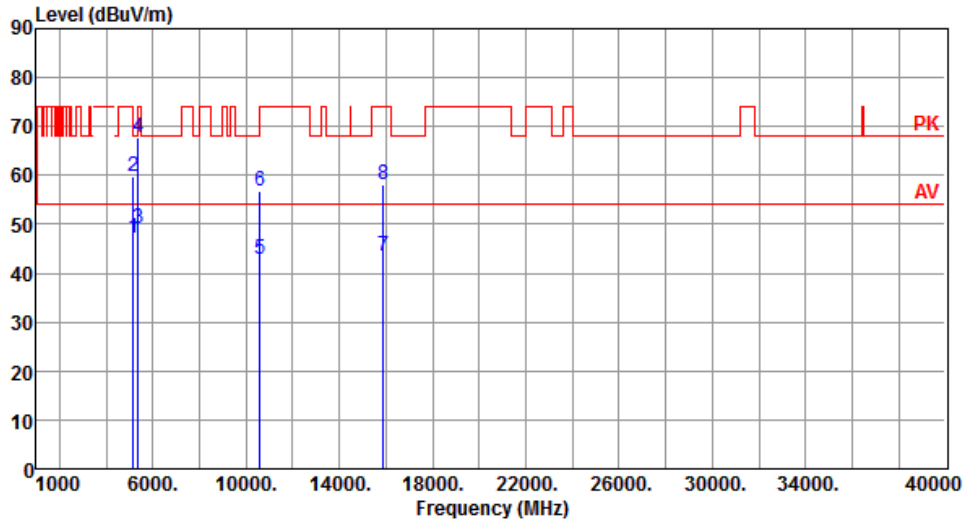

	Freq. MHz	Emission level dBuV/m	Limit dBuV/m	Margin dB	SA reading dBuV	Factor dB	Remark	ANT High cm	Turn Table deg
1	5150.00	47.11	54.00	-6.89	42.87	4.24	Average	179	139
2	5150.00	59.88	74.00	-14.12	55.64	4.24	Peak	179	139
3	5350.00	49.05	54.00	-4.95	44.62	4.43	Average	179	139
4	5350.00	67.67	74.00	-6.33	63.24	4.43	Peak	179	139
5	10600.00	42.81	54.00	-11.19	28.94	13.87	Average	100	149
6	10600.00	56.72	74.00	-17.28	42.85	13.87	Peak	100	149
7	15900.00	43.47	54.00	-10.53	28.99	14.48	Average	100	153
8	15900.00	58.05	74.00	-15.95	43.57	14.48	Peak	100	153

Note 1: Emission Level (dBuV/m) = SA Reading (dBuV/m) + Factor* (dB)

*Factor includes antenna factor , cable loss and amplifier gain

Note 2: Margin (dB) = Emission level (dBuV/m) – Limit (dBuV/m).

Modulation	11a	Test Freq. (MHz)	5320
Polarization	Horizontal		

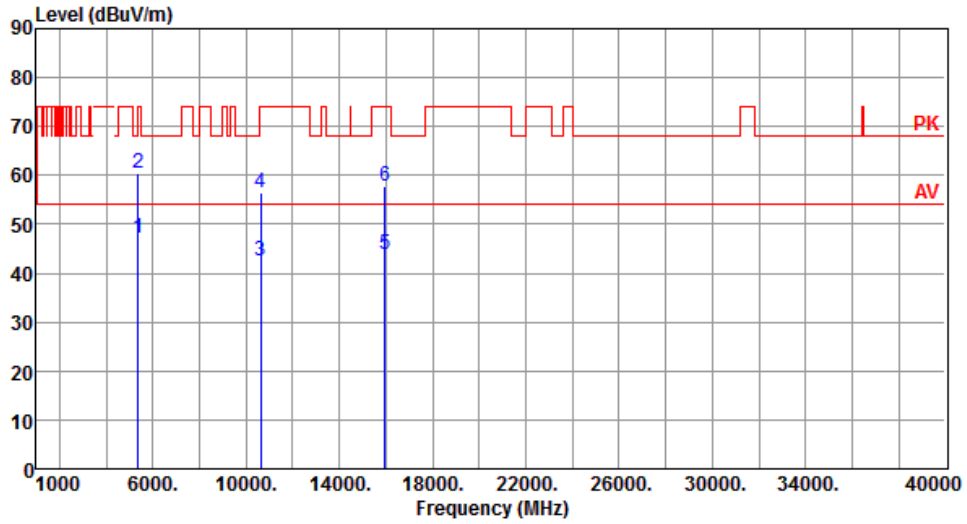

	Freq. MHz	Emission level dBuV/m	Limit dBuV/m	Margin dB	SA reading dBuV	Factor dB	Remark	ANT High cm	Turn Table deg
1	5350.00	47.26	54.00	-6.74	42.83	4.43	Average	187	85
2	5350.00	60.38	74.00	-13.62	55.95	4.43	Peak	187	85
3	10640.00	42.60	54.00	-11.40	28.68	13.92	Average	100	89
4	10640.00	56.61	74.00	-17.39	42.69	13.92	Peak	100	89
5	15960.00	43.94	54.00	-10.06	29.50	14.44	Average	100	91
6	15960.00	57.66	74.00	-16.34	43.22	14.44	Peak	100	91

Note 1: Emission Level (dBuV/m) = SA Reading (dBuV/m) + Factor* (dB)

*Factor includes antenna factor , cable loss and amplifier gain

Note 2: Margin (dB) = Emission level (dBuV/m) – Limit (dBuV/m).

Modulation	11a	Test Freq. (MHz)	5320
Polarization	Vertical		

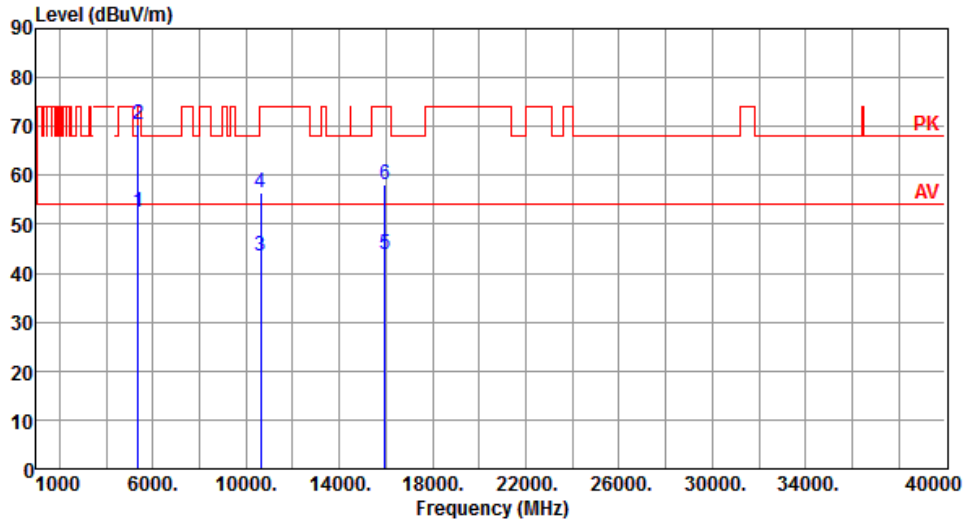

	Freq. MHz	Emission level dBuV/m	Limit dBuV/m	Margin dB	SA reading dBuV	Factor dB	Remark	ANT High cm	Turn Table deg
1	5350.00	52.33	54.00	-1.67	47.90	4.43	Average	179	141
2	5350.00	70.35	74.00	-3.65	65.92	4.43	Peak	179	141
3	10640.00	43.52	54.00	-10.48	29.60	13.92	Average	100	154
4	10640.00	56.60	74.00	-17.40	42.68	13.92	Peak	100	154
5	15960.00	43.85	54.00	-10.15	29.41	14.44	Average	100	149
6	15960.00	58.10	74.00	-15.90	43.66	14.44	Peak	100	149

Note 1: Emission Level (dBuV/m) = SA Reading (dBuV/m) + Factor* (dB)

*Factor includes antenna factor , cable loss and amplifier gain

Note 2: Margin (dB) = Emission level (dBuV/m) – Limit (dBuV/m).

Modulation	11a	Test Freq. (MHz)	5500
Polarization	Horizontal		

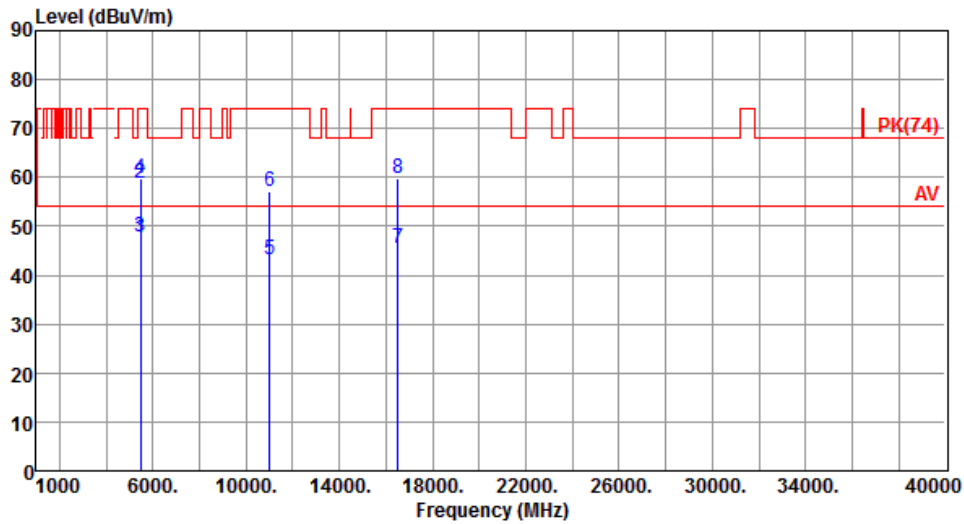

	Freq. MHz	Emission level dBuV/m	Limit dBuV/m	Margin dB	SA reading dBuV	Factor dB	Remark	ANT High cm	Turn Table deg
1	5460.00	47.36	54.00	-6.64	42.85	4.51	Average	204	92
2	5460.00	58.65	74.00	-15.35	54.14	4.51	Peak	204	92
3	5470.00	47.72	54.00	-6.28	43.20	4.52	Average	204	92
4	5470.00	59.93	74.00	-14.07	55.41	4.52	Peak	204	92
5	11000.00	43.24	54.00	-10.76	28.90	14.34	Average	100	95
6	11000.00	57.24	74.00	-16.76	42.90	14.34	Peak	100	95
7	16500.00	45.61	54.00	-8.39	29.13	16.48	Average	100	97
8	16500.00	59.72	74.00	-14.28	43.24	16.48	Peak	100	97

Note 1: Emission Level (dBuV/m) = SA Reading (dBuV/m) + Factor* (dB)

*Factor includes antenna factor , cable loss and amplifier gain

Note 2: Margin (dB) = Emission level (dBuV/m) – Limit (dBuV/m).

Modulation	11a	Test Freq. (MHz)	5500
Polarization	Vertical		

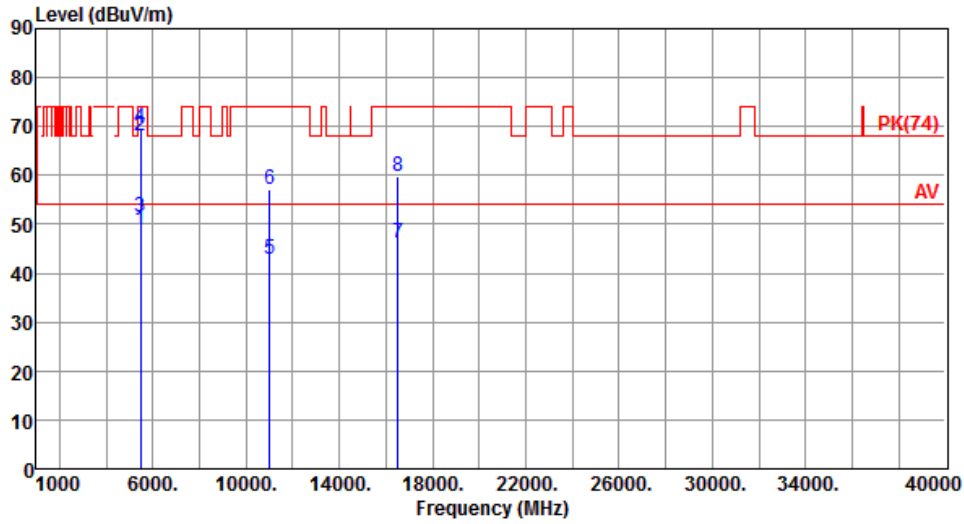

	Freq. MHz	Emission level dBuV/m	Limit dBuV/m	Margin dB	SA reading dBuV	Factor dB	Remark	ANT High cm	Turn Table deg
1	5460.00	48.71	54.00	-5.29	44.20	4.51	Average	168	141
2	5460.00	68.16	74.00	-5.84	63.65	4.51	Peak	168	141
3	5470.00	51.42	54.00	-2.58	46.90	4.52	Average	168	141
4	5470.00	69.69	74.00	-4.31	65.17	4.52	Peak	168	141
5	11000.00	42.92	54.00	-11.08	28.58	14.34	Average	100	140
6	11000.00	57.19	74.00	-16.81	42.85	14.34	Peak	100	140
7	16500.00	46.08	54.00	-7.92	29.60	16.48	Average	100	145
8	16500.00	59.73	74.00	-14.27	43.25	16.48	Peak	100	145

Note 1: Emission Level (dBuV/m) = SA Reading (dBuV/m) + Factor* (dB)

*Factor includes antenna factor , cable loss and amplifier gain

Note 2: Margin (dB) = Emission level (dBuV/m) – Limit (dBuV/m).

Modulation	11a	Test Freq. (MHz)	5580
Polarization	Horizontal		

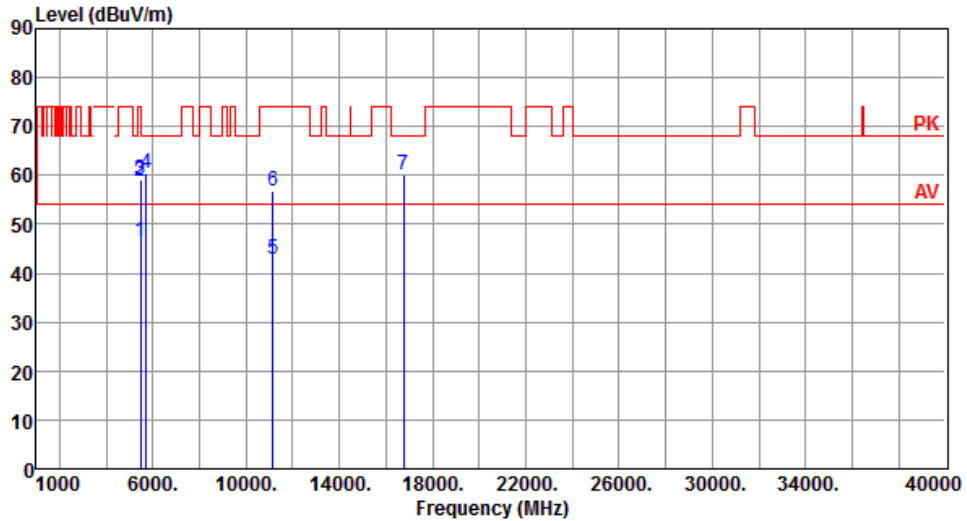

	Freq. MHz	Emission level dBuV/m	Limit dBuV/m	Margin dB	SA reading dBuV	Factor dB	Remark	ANT High cm	Turn Table deg
1	5460.00	46.65	54.00	-7.35	42.14	4.51	Average	184	88
2	5460.00	58.72	74.00	-15.28	54.21	4.51	Peak	184	88
3	5470.00	59.19	68.20	-9.01	54.67	4.52	Peak	184	88
4	5725.00	60.29	68.20	-7.91	55.47	4.82	Peak	184	88
5	11160.00	42.77	54.00	-11.23	28.57	14.20	Average	100	104
6	11160.00	56.87	74.00	-17.13	42.67	14.20	Peak	100	104
7	16740.00	60.16	68.20	-8.04	43.24	16.92	Peak	100	109

Note 1: Emission Level (dBuV/m) = SA Reading (dBuV/m) + Factor* (dB)

*Factor includes antenna factor , cable loss and amplifier gain

Note 2: Margin (dB) = Emission level (dBuV/m) – Limit (dBuV/m).

Modulation	11a	Test Freq. (MHz)	5580
Polarization	Vertical		

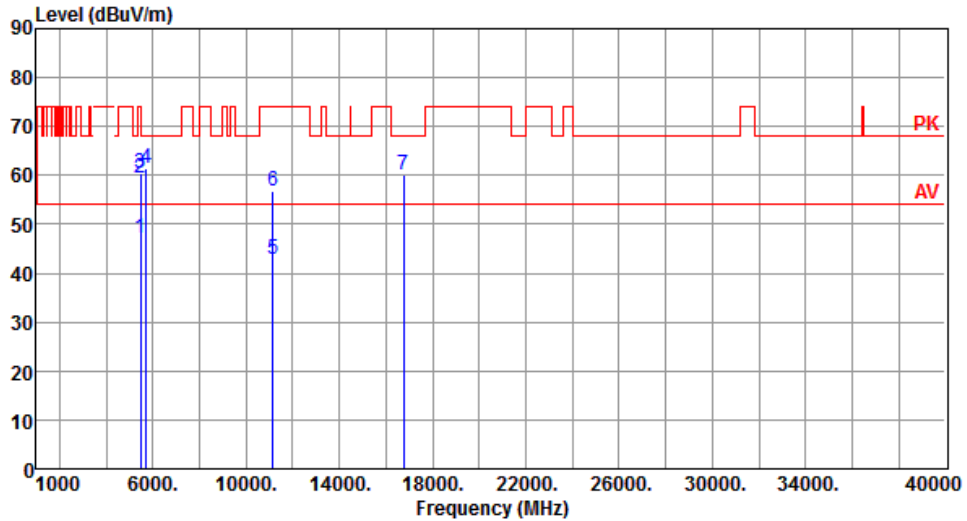

	Freq. MHz	Emission level dBuV/m	Limit dBuV/m	Margin dB	SA reading dBuV	Factor dB	Remark	ANT High cm	Turn Table deg
1	5460.00	47.11	54.00	-6.89	42.60	4.51	Average	159	110
2	5460.00	59.46	74.00	-14.54	54.95	4.51	Peak	159	110
3	5470.00	60.37	68.20	-7.83	55.85	4.52	Peak	159	110
4	5725.00	61.51	68.20	-6.69	56.69	4.82	Peak	159	110
5	11160.00	42.88	54.00	-11.12	28.68	14.20	Average	100	154
6	11160.00	56.89	74.00	-17.11	42.69	14.20	Peak	100	154
7	16740.00	60.02	68.20	-8.18	43.10	16.92	Peak	100	151

Note 1: Emission Level (dBuV/m) = SA Reading (dBuV/m) + Factor* (dB)

*Factor includes antenna factor , cable loss and amplifier gain

Note 2: Margin (dB) = Emission level (dBuV/m) – Limit (dBuV/m).

Modulation	11a	Test Freq. (MHz)	5700
Polarization	Horizontal		

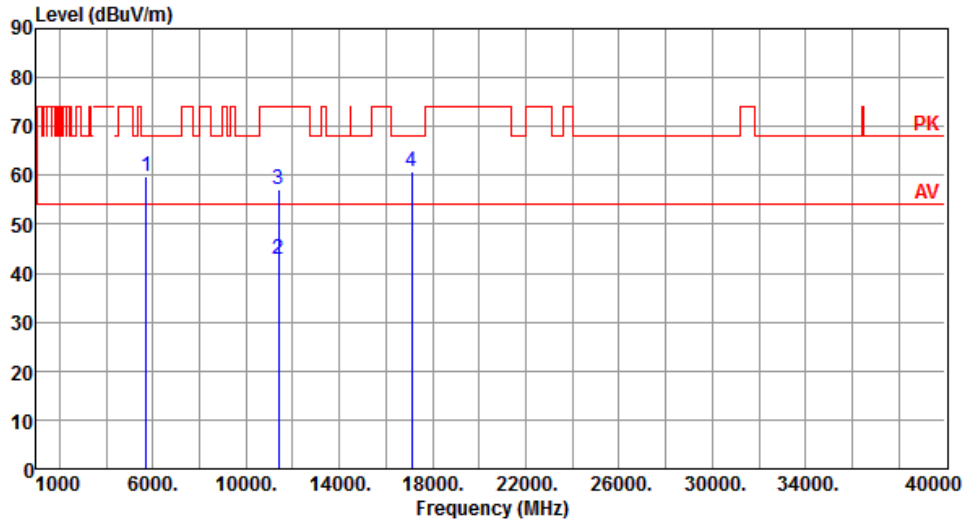

	Freq. MHz	Emission level dBuV/m	Limit dBuV/m	Margin dB	SA reading dBuV	Factor dB	Remark	ANT High cm	Turn Table deg
1	5725.00	59.92	68.20	-8.28	55.10	4.82	Peak	220	103
2	11400.00	42.69	54.00	-11.31	28.69	14.00	Average	100	100
3	11400.00	56.97	74.00	-17.03	42.97	14.00	Peak	100	100
4	17100.00	60.86	68.20	-7.34	43.19	17.67	Peak	100	99

Note 1: Emission Level (dBuV/m) = SA Reading (dBuV/m) + Factor* (dB)

*Factor includes antenna factor , cable loss and amplifier gain

Note 2: Margin (dB) = Emission level (dBuV/m) – Limit (dBuV/m).

Modulation	11a	Test Freq. (MHz)	5700
Polarization	Vertical		

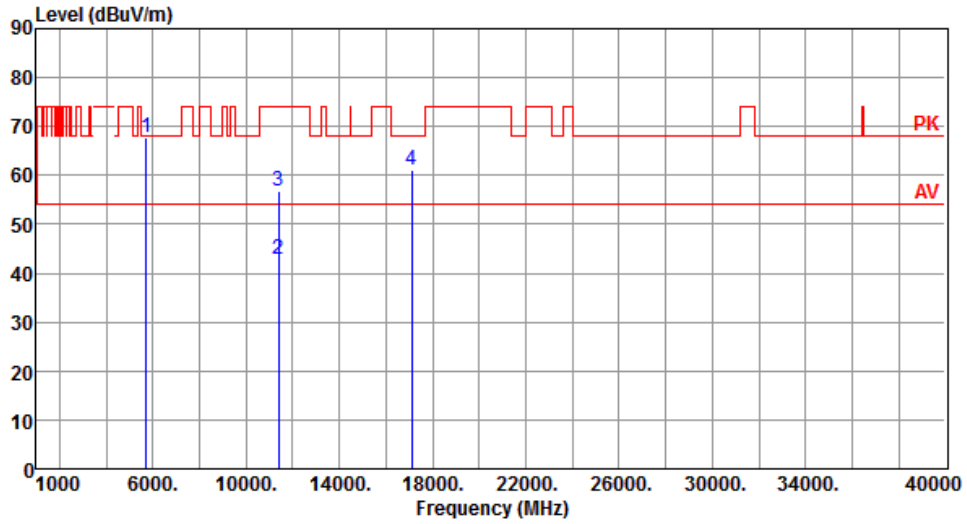

	Freq. MHz	Emission level dBuV/m	Limit dBuV/m	Margin dB	SA reading dBuV	Factor dB	Remark	ANT High cm	Turn Table deg
1	5725.00	67.65	68.20	-0.55	62.83	4.82	Peak	167	105
2	11400.00	42.99	54.00	-11.01	28.99	14.00	Average	100	109
3	11400.00	56.87	74.00	-17.13	42.87	14.00	Peak	100	109
4	17100.00	61.24	68.20	-6.96	43.57	17.67	Peak	100	95

Note 1: Emission Level (dBuV/m) = SA Reading (dBuV/m) + Factor* (dB)

*Factor includes antenna factor , cable loss and amplifier gain

Note 2: Margin (dB) = Emission level (dBuV/m) – Limit (dBuV/m).

Modulation	11a	Test Freq. (MHz)	5720
Polarization	Horizontal		

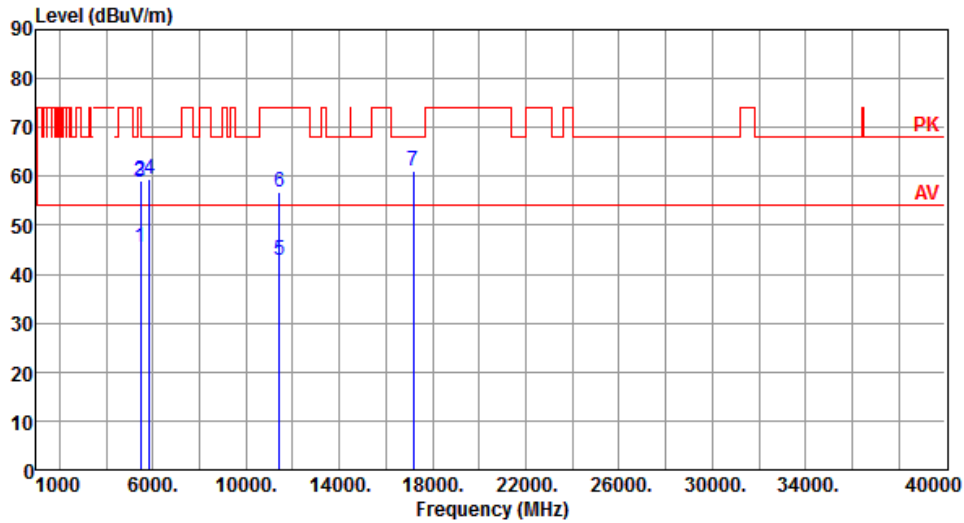

	Freq. MHz	Emission level dBuV/m	Limit dBuV/m	Margin dB	SA reading dBuV	Factor dB	Remark	ANT High cm	Turn Table deg
1	5460.00	45.52	54.00	-8.48	41.01	4.51	Average	220	98
2	5460.00	59.21	74.00	-14.79	54.70	4.51	Peak	220	98
3	5470.00	58.79	68.20	-9.41	54.27	4.52	Peak	220	98
4	5850.00	59.43	68.20	-8.77	54.44	4.99	Peak	220	98
5	11440.00	42.90	54.00	-11.10	28.94	13.96	Average	100	102
6	11440.00	56.65	74.00	-17.35	42.69	13.96	Peak	100	102
7	17160.00	61.14	68.20	-7.06	43.31	17.83	Peak	100	101

Note 1: Emission Level (dBuV/m) = SA Reading (dBuV/m) + Factor* (dB)

*Factor includes antenna factor , cable loss and amplifier gain

Note 2: Margin (dB) = Emission level (dBuV/m) – Limit (dBuV/m).

Modulation	11a	Test Freq. (MHz)	5720
Polarization	Vertical		

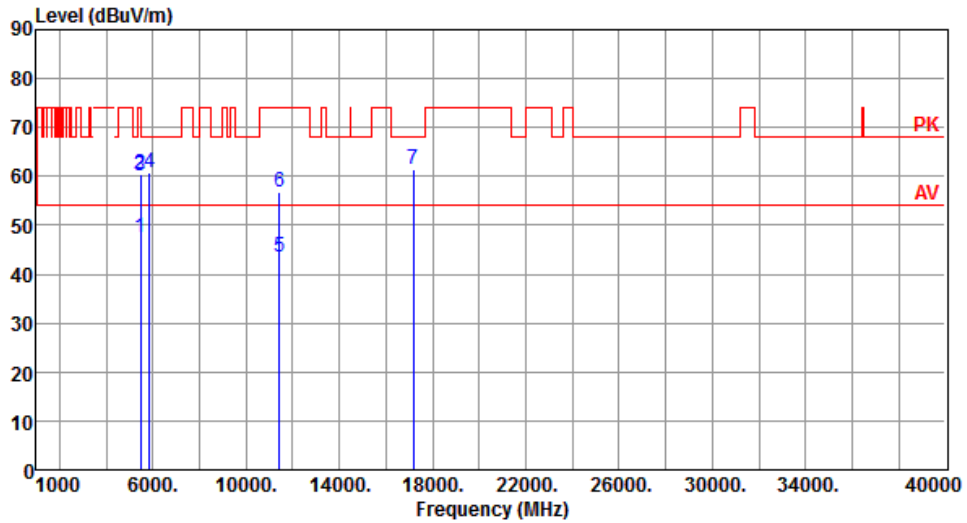

	Freq. MHz	Emission level dBuV/m	Limit dBuV/m	Margin dB	SA reading dBuV	Factor dB	Remark	ANT High cm	Turn Table deg
1	5460.00	47.40	54.00	-6.60	42.89	4.51	Average	162	148
2	5460.00	60.52	74.00	-13.48	56.01	4.51	Peak	162	148
3	5470.00	60.27	68.20	-7.93	55.75	4.52	Peak	162	148
4	5850.00	60.88	68.20	-7.32	55.89	4.99	Peak	162	148
5	11440.00	43.50	54.00	-10.50	29.54	13.96	Average	100	151
6	11440.00	56.93	74.00	-17.07	42.97	13.96	Peak	100	151
7	17160.00	61.37	68.20	-6.83	43.54	17.83	Peak	100	150

Note 1: Emission Level (dBuV/m) = SA Reading (dBuV/m) + Factor* (dB)

*Factor includes antenna factor , cable loss and amplifier gain

Note 2: Margin (dB) = Emission level (dBuV/m) – Limit (dBuV/m).

Modulation	11a	Test Freq. (MHz)	5745
Polarization	Horizontal		

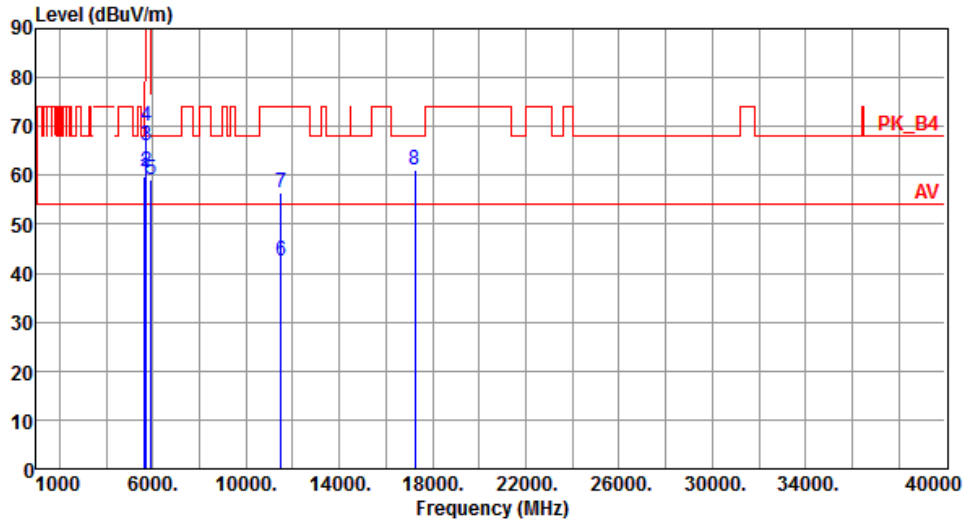

	Freq. MHz	Emission level dBuV/m	Limit dBuV/m	Margin dB	SA reading dBuV	Factor dB	Remark	ANT High cm	Turn Table deg
1	5650.00	59.77	68.20	-8.43	55.04	4.73	Peak	189	93
2	5700.00	60.71	105.20	-44.49	55.92	4.79	Peak	189	93
3	5720.00	66.14	110.80	-44.66	61.32	4.82	Peak	189	93
4	5725.00	70.12	122.20	-52.08	65.30	4.82	Peak	189	93
5	5925.00	59.01	68.20	-9.19	53.93	5.08	Peak	189	93
6	11490.00	42.52	54.00	-11.48	28.60	13.92	Average	100	95
7	11490.00	56.61	74.00	-17.39	42.69	13.92	Peak	100	95
8	17235.00	61.25	68.20	-6.95	43.22	18.03	Peak	100	102

Note 1: Emission Level (dBuV/m) = SA Reading (dBuV/m) + Factor* (dB)

*Factor includes antenna factor , cable loss and amplifier gain

Note 2: Margin (dB) = Emission level (dBuV/m) – Limit (dBuV/m).

Modulation	11a	Test Freq. (MHz)	5745
Polarization	Vertical		

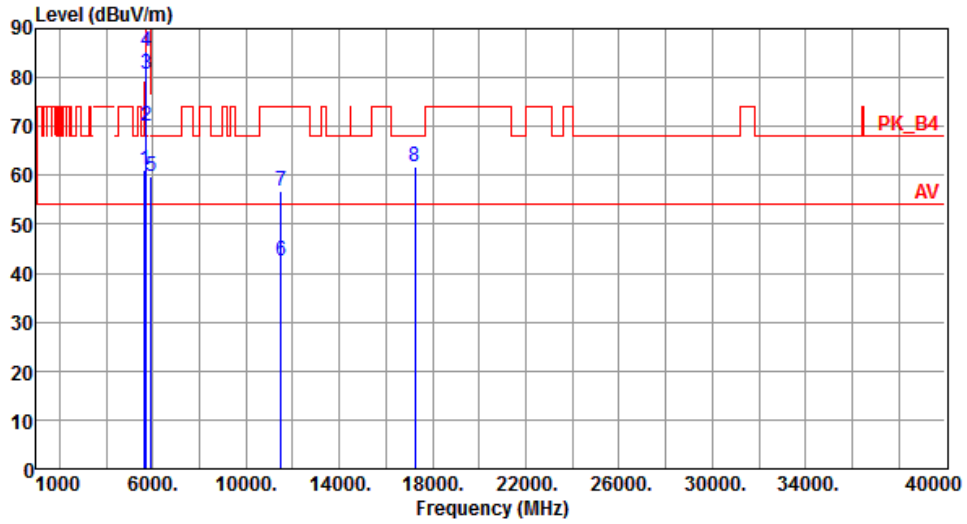

	Freq. MHz	Emission level dBuV/m	Limit dBuV/m	Margin dB	SA reading dBuV	Factor dB	Remark	ANT High cm	Turn Table deg
1	5650.00	60.98	68.20	-7.22	56.25	4.73	Peak	161	153
2	5700.00	69.98	105.20	-35.22	65.19	4.79	Peak	161	153
3	5720.00	80.67	110.80	-30.13	75.85	4.82	Peak	161	153
4	5725.00	85.35	122.20	-36.85	80.53	4.82	Peak	161	153
5	5925.00	59.77	68.20	-8.43	54.69	5.08	Peak	161	153
6	11490.00	42.61	54.00	-11.39	28.69	13.92	Average	100	159
7	11490.00	56.78	74.00	-17.22	42.86	13.92	Peak	100	159
8	17235.00	61.69	68.20	-6.51	43.66	18.03	Peak	100	155

Note 1: Emission Level (dBuV/m) = SA Reading (dBuV/m) + Factor* (dB)

*Factor includes antenna factor , cable loss and amplifier gain

Note 2: Margin (dB) = Emission level (dBuV/m) – Limit (dBuV/m).

Modulation	11a	Test Freq. (MHz)	5785
Polarization	Horizontal		

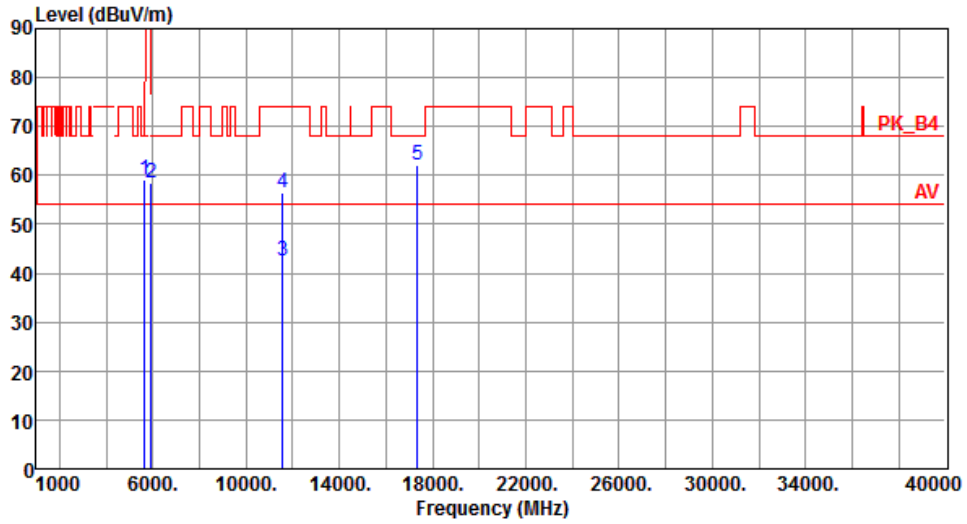

	Freq. MHz	Emission level dBuV/m	Limit dBuV/m	Margin dB	SA reading dBuV	Factor dB	Remark	ANT High cm	Turn Table deg
1	5650.00	59.03	68.20	-9.17	54.30	4.73	Peak	217	102
2	5925.00	58.29	68.20	-9.91	53.21	5.08	Peak	217	102
3	11570.00	42.41	54.00	-11.59	28.58	13.83	Average	100	108
4	11570.00	56.50	74.00	-17.50	42.67	13.83	Peak	100	108
5	17355.00	62.02	68.20	-6.18	43.66	18.36	Peak	100	105

Note 1: Emission Level (dBuV/m) = SA Reading (dBuV/m) + Factor* (dB)

*Factor includes antenna factor , cable loss and amplifier gain

Note 2: Margin (dB) = Emission level (dBuV/m) – Limit (dBuV/m).

Modulation	11a	Test Freq. (MHz)	5785
Polarization	Vertical		

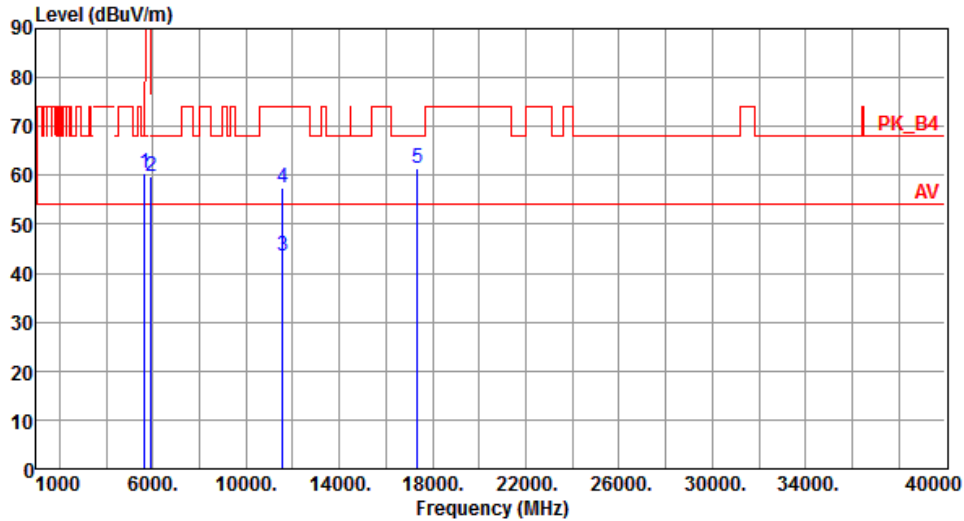

	Freq. MHz	Emission level dBuV/m	Limit dBuV/m	Margin dB	SA reading dBuV	Factor dB	Remark	ANT High cm	Turn Table deg
1	5650.00	60.37	68.20	-7.83	55.64	4.73	Peak	178	146
2	5925.00	59.77	68.20	-8.43	54.69	5.08	Peak	178	146
3	11570.00	43.40	54.00	-10.60	29.57	13.83	Average	100	151
4	11570.00	57.51	74.00	-16.49	43.68	13.83	Peak	100	151
5	17355.00	61.36	68.20	-6.84	43.00	18.36	Peak	100	153

Note 1: Emission Level (dBuV/m) = SA Reading (dBuV/m) + Factor* (dB)

*Factor includes antenna factor , cable loss and amplifier gain

Note 2: Margin (dB) = Emission level (dBuV/m) – Limit (dBuV/m).

Modulation	11a	Test Freq. (MHz)	5825
Polarization	Horizontal		

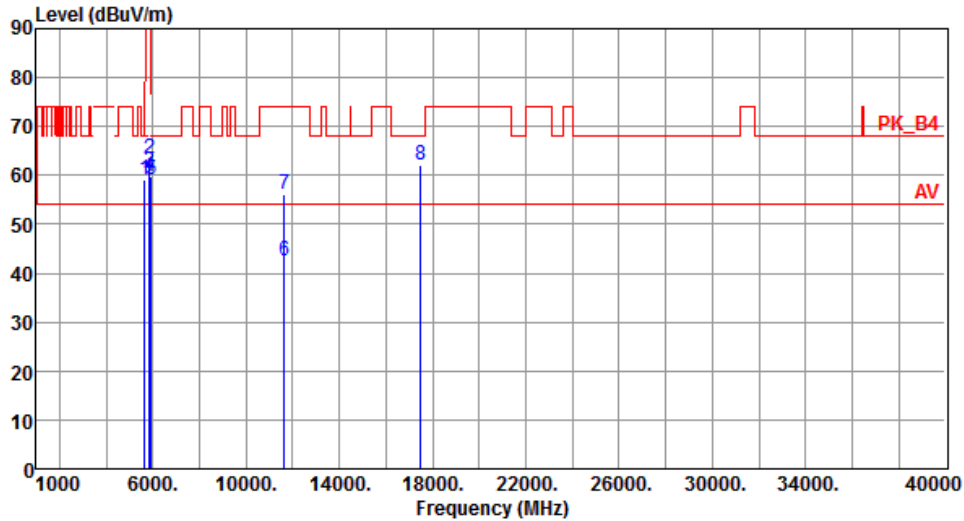

	Freq. MHz	Emission level dBuV/m	Limit dBuV/m	Margin dB	SA reading dBuV	Factor dB	Remark	ANT High cm	Turn Table deg
1	5650.00	59.26	68.20	-8.94	54.53	4.73	Peak	191	97
2	5850.00	63.58	122.20	-58.62	58.59	4.99	Peak	191	97
3	5855.00	60.79	110.80	-50.01	55.79	5.00	Peak	191	97
4	5875.00	59.69	105.20	-45.51	54.67	5.02	Peak	191	97
5	5925.00	59.18	68.20	-9.02	54.10	5.08	Peak	191	97
6	11650.00	42.41	54.00	-11.59	28.67	13.74	Average	100	101
7	11650.00	56.10	74.00	-17.90	42.36	13.74	Peak	100	101
8	17475.00	62.20	68.20	-6.00	43.51	18.69	Peak	100	100

Note 1: Emission Level (dBuV/m) = SA Reading (dBuV/m) + Factor* (dB)

*Factor includes antenna factor , cable loss and amplifier gain

Note 2: Margin (dB) = Emission level (dBuV/m) – Limit (dBuV/m).

Modulation	11a	Test Freq. (MHz)	5825
Polarization	Vertical		

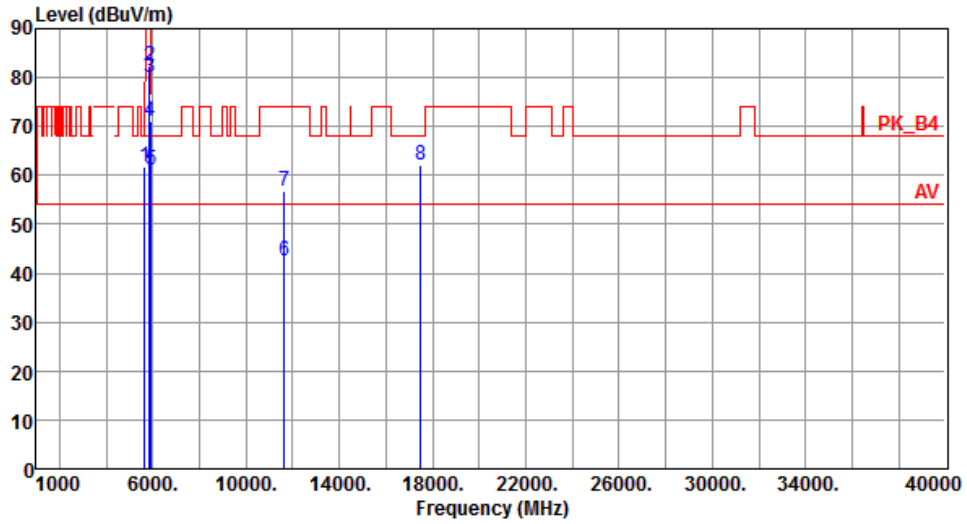

	Freq. MHz	Emission level dBuV/m	Limit dBuV/m	Margin dB	SA reading dBuV	Factor dB	Remark	ANT High cm	Turn Table deg
1	5650.00	61.84	68.20	-6.36	57.11	4.73	Peak	172	145
2	5850.00	82.48	122.20	-39.72	77.49	4.99	Peak	172	145
3	5855.00	79.92	110.80	-30.88	74.92	5.00	Peak	172	145
4	5875.00	70.95	105.20	-34.25	65.93	5.02	Peak	172	145
5	5925.00	61.18	68.20	-7.02	56.10	5.08	Peak	172	145
6	11650.00	42.41	54.00	-11.59	28.67	13.74	Average	100	146
7	11650.00	56.65	74.00	-17.35	42.91	13.74	Peak	100	146
8	17475.00	62.00	68.20	-6.20	43.31	18.69	Peak	100	142

Note 1: Emission Level (dBuV/m) = SA Reading (dBuV/m) + Factor* (dB)

*Factor includes antenna factor , cable loss and amplifier gain

Note 2: Margin (dB) = Emission level (dBuV/m) – Limit (dBuV/m).

3.5.6 Transmitter Radiated Unwanted Emissions (Above 1GHz) for VHT20

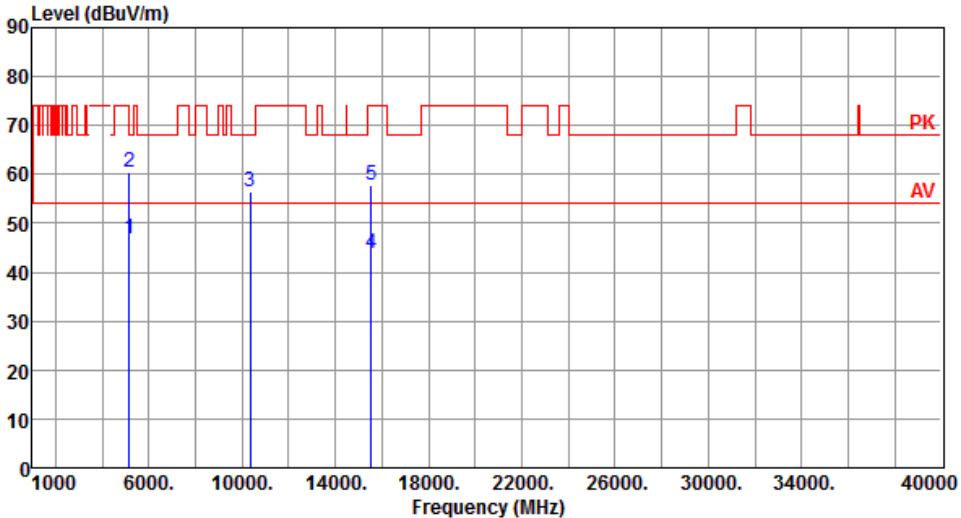
Modulation	VHT20	Test Freq. (MHz)	5180																																																																		
Polarization	Horizontal																																																																				
																																																																					
	<table border="1"> <thead> <tr> <th>Freq.</th> <th>Emission level</th> <th>Limit</th> <th>Margin</th> <th>SA reading</th> <th>Factor</th> <th>Remark</th> <th>ANT High</th> <th>Turn Table</th> </tr> <tr> <th>MHz</th> <th>dBuV/m</th> <th>dBuV/m</th> <th>dB</th> <th>dBuV</th> <th>dB</th> <th></th> <th>cm</th> <th>deg</th> </tr> </thead> <tbody> <tr> <td>1</td> <td>5150.00</td> <td>46.75</td> <td>54.00</td> <td>-7.25</td> <td>42.51</td> <td>4.24</td> <td>Average</td> <td>208</td> <td>91</td> </tr> <tr> <td>2</td> <td>5150.00</td> <td>60.37</td> <td>74.00</td> <td>-13.63</td> <td>56.13</td> <td>4.24</td> <td>Peak</td> <td>208</td> <td>91</td> </tr> <tr> <td>3</td> <td>10360.00</td> <td>56.33</td> <td>68.20</td> <td>-11.87</td> <td>42.64</td> <td>13.69</td> <td>Peak</td> <td>100</td> <td>105</td> </tr> <tr> <td>4</td> <td>15540.00</td> <td>43.92</td> <td>54.00</td> <td>-10.08</td> <td>29.23</td> <td>14.69</td> <td>Average</td> <td>100</td> <td>101</td> </tr> <tr> <td>5</td> <td>15540.00</td> <td>57.94</td> <td>74.00</td> <td>-16.06</td> <td>43.25</td> <td>14.69</td> <td>Peak</td> <td>100</td> <td>101</td> </tr> </tbody> </table>	Freq.	Emission level	Limit	Margin	SA reading	Factor	Remark	ANT High	Turn Table	MHz	dBuV/m	dBuV/m	dB	dBuV	dB		cm	deg	1	5150.00	46.75	54.00	-7.25	42.51	4.24	Average	208	91	2	5150.00	60.37	74.00	-13.63	56.13	4.24	Peak	208	91	3	10360.00	56.33	68.20	-11.87	42.64	13.69	Peak	100	105	4	15540.00	43.92	54.00	-10.08	29.23	14.69	Average	100	101	5	15540.00	57.94	74.00	-16.06	43.25	14.69	Peak	100	101
Freq.	Emission level	Limit	Margin	SA reading	Factor	Remark	ANT High	Turn Table																																																													
MHz	dBuV/m	dBuV/m	dB	dBuV	dB		cm	deg																																																													
1	5150.00	46.75	54.00	-7.25	42.51	4.24	Average	208	91																																																												
2	5150.00	60.37	74.00	-13.63	56.13	4.24	Peak	208	91																																																												
3	10360.00	56.33	68.20	-11.87	42.64	13.69	Peak	100	105																																																												
4	15540.00	43.92	54.00	-10.08	29.23	14.69	Average	100	101																																																												
5	15540.00	57.94	74.00	-16.06	43.25	14.69	Peak	100	101																																																												
<p>Note 1: Emission Level (dBuV/m) = SA Reading (dBuV/m) + Factor* (dB) *Factor includes antenna factor , cable loss and amplifier gain Note 2: Margin (dB) = Emission level (dBuV/m) – Limit (dBuV/m).</p>																																																																					

Modulation	VHT20	Test Freq. (MHz)	5180
Polarization	Vertical		

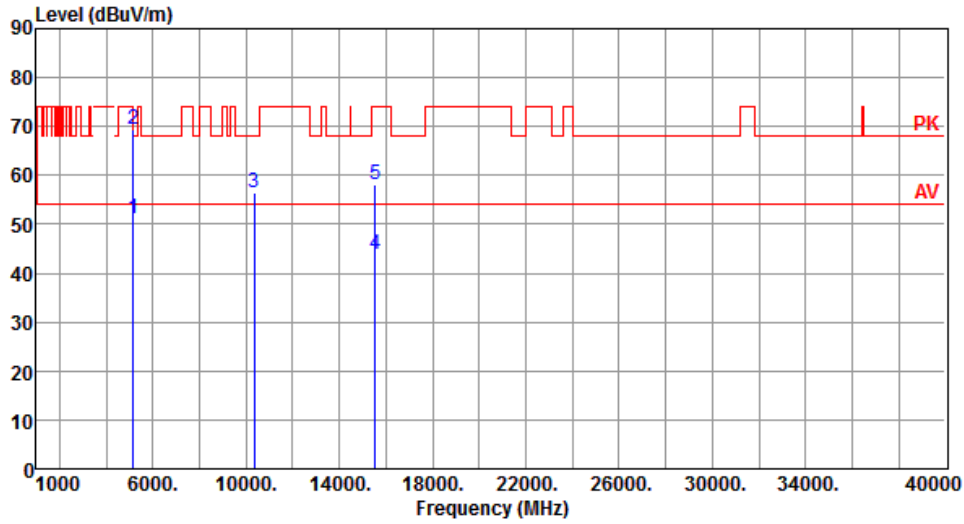

	Freq. MHz	Emission level dBuV/m	Limit dBuV/m	Margin dB	SA reading dBuV	Factor dB	Remark	ANT High cm	Turn Table deg
1	5150.00	51.16	54.00	-2.84	46.92	4.24	Average	100	147
2	5150.00	69.35	74.00	-4.65	65.11	4.24	Peak	100	147
3	10360.00	56.34	68.20	-11.86	42.65	13.69	Peak	100	153
4	15540.00	44.00	54.00	-10.00	29.31	14.69	Average	100	144
5	15540.00	57.99	74.00	-16.01	43.30	14.69	Peak	100	144

Note 1: Emission Level (dBuV/m) = SA Reading (dBuV/m) + Factor* (dB)

*Factor includes antenna factor , cable loss and amplifier gain

Note 2: Margin (dB) = Emission level (dBuV/m) – Limit (dBuV/m).

Modulation	VHT20	Test Freq. (MHz)	5200
Polarization	Horizontal		

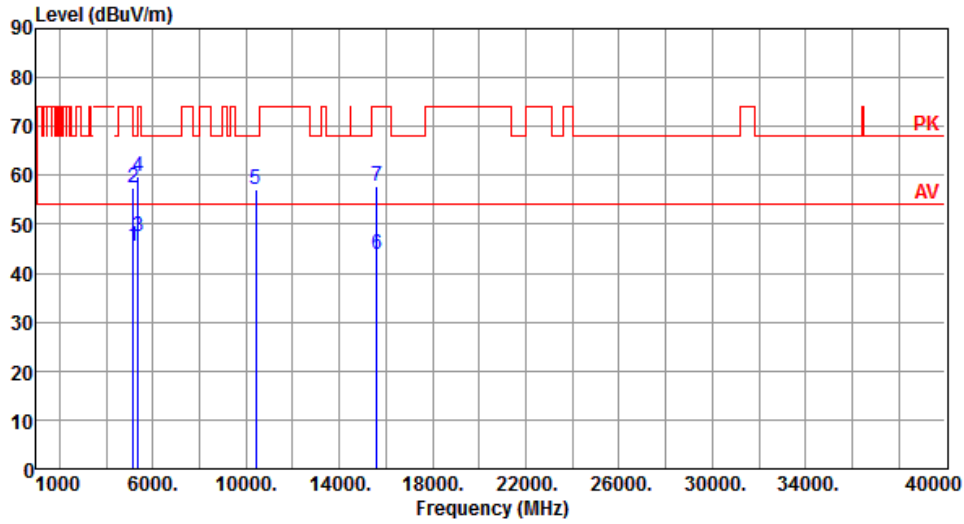

	Freq. MHz	Emission level dBuV/m	Limit dBuV/m	Margin dB	SA reading dBuV	Factor dB	Remark	ANT High cm	Turn Table deg
1	5150.00	45.57	54.00	-8.43	41.33	4.24	Average	222	91
2	5150.00	57.46	74.00	-16.54	53.22	4.24	Peak	222	91
3	5350.00	47.56	54.00	-6.44	43.13	4.43	Average	222	91
4	5350.00	59.83	74.00	-14.17	55.40	4.43	Peak	222	91
5	10400.00	57.15	68.20	-11.05	43.44	13.71	Peak	100	95
6	15600.00	43.75	54.00	-10.25	29.10	14.65	Average	100	103
7	15600.00	57.75	74.00	-16.25	43.10	14.65	Peak	100	103

Note 1: Emission Level (dBuV/m) = SA Reading (dBuV/m) + Factor* (dB)

*Factor includes antenna factor , cable loss and amplifier gain

Note 2: Margin (dB) = Emission level (dBuV/m) – Limit (dBuV/m).

Modulation	VHT20	Test Freq. (MHz)	5200
Polarization	Vertical		

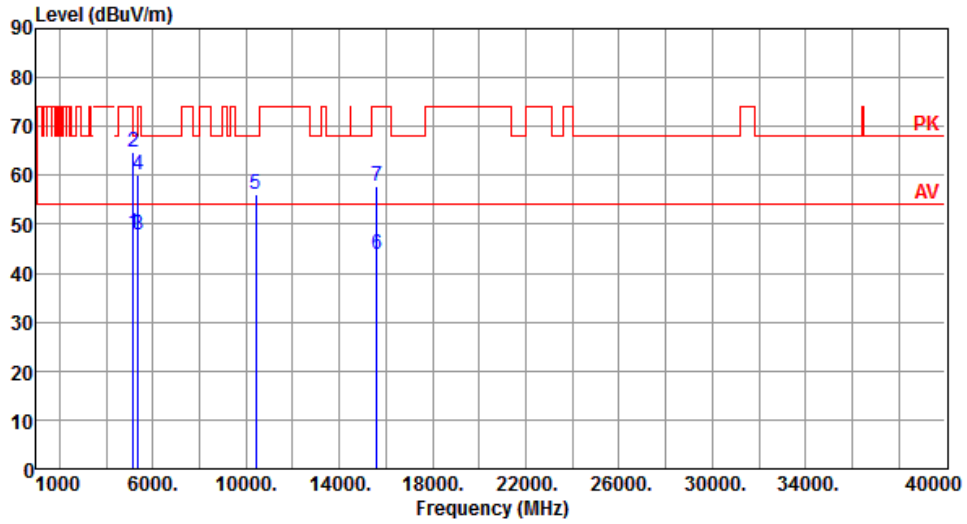

	Freq. MHz	Emission level dBuV/m	Limit dBuV/m	Margin dB	SA reading dBuV	Factor dB	Remark	ANT High cm	Turn Table deg
1	5150.00	48.17	54.00	-5.83	43.93	4.24	Average	206	143
2	5150.00	64.75	74.00	-9.25	60.51	4.24	Peak	206	143
3	5350.00	47.87	54.00	-6.13	43.44	4.43	Average	206	143
4	5350.00	59.97	74.00	-14.03	55.54	4.43	Peak	206	143
5	10400.00	56.25	68.20	-11.95	42.54	13.71	Peak	100	152
6	15600.00	43.99	54.00	-10.01	29.34	14.65	Average	100	147
7	15600.00	57.90	74.00	-16.10	43.25	14.65	Peak	100	147

Note 1: Emission Level (dBuV/m) = SA Reading (dBuV/m) + Factor* (dB)

*Factor includes antenna factor , cable loss and amplifier gain

Note 2: Margin (dB) = Emission level (dBuV/m) – Limit (dBuV/m).

Modulation	VHT20	Test Freq. (MHz)	5240
Polarization	Horizontal		

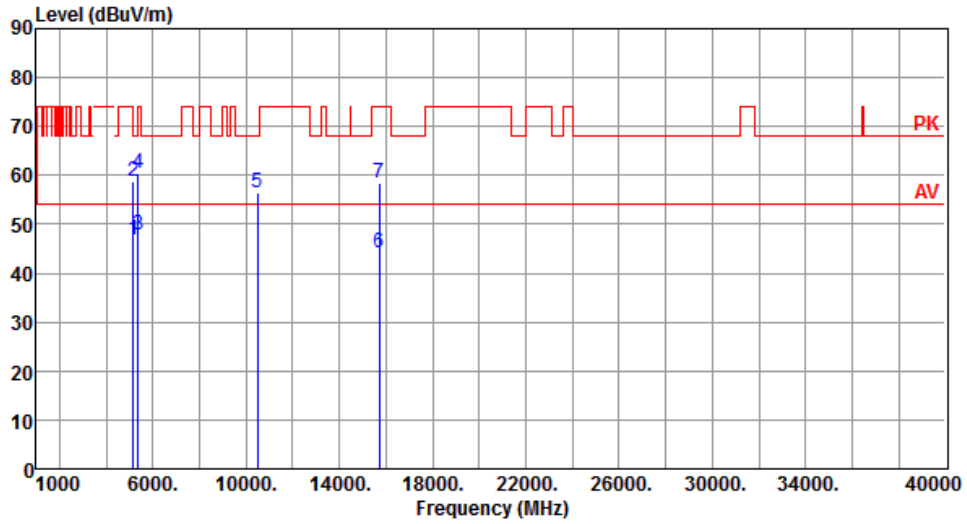

	Freq. MHz	Emission level dBuV/m	Limit dBuV/m	Margin dB	SA reading dBuV	Factor dB	Remark	ANT High cm	Turn Table deg
1	5150.00	46.88	54.00	-7.12	42.64	4.24	Average	178	95
2	5150.00	58.78	74.00	-15.22	54.54	4.24	Peak	178	95
3	5350.00	47.97	54.00	-6.03	43.54	4.43	Average	178	95
4	5350.00	60.30	74.00	-13.70	55.87	4.43	Peak	178	95
5	10480.00	56.59	68.20	-11.61	42.85	13.74	Peak	100	100
6	15720.00	44.12	54.00	-9.88	29.54	14.58	Average	100	98
7	15720.00	58.45	74.00	-15.55	43.87	14.58	Peak	100	98

Note 1: Emission Level (dBuV/m) = SA Reading (dBuV/m) + Factor* (dB)

*Factor includes antenna factor , cable loss and amplifier gain

Note 2: Margin (dB) = Emission level (dBuV/m) – Limit (dBuV/m).

Modulation	VHT20	Test Freq. (MHz)	5240
Polarization	Vertical		

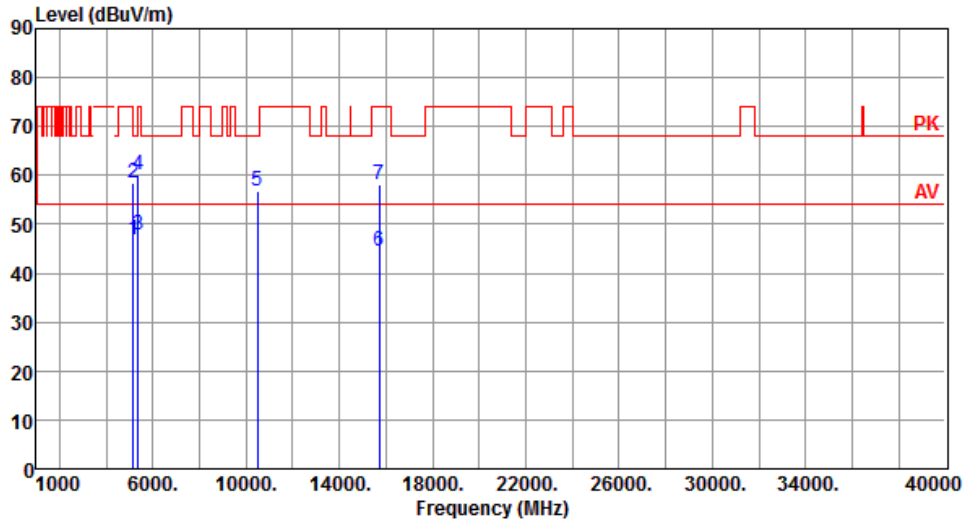

	Freq. MHz	Emission level dBuV/m	Limit dBuV/m	Margin dB	SA reading dBuV	Factor dB	Remark	ANT High cm	Turn Table deg
1	5150.00	46.78	54.00	-7.22	42.54	4.24	Average	201	151
2	5150.00	58.38	74.00	-15.62	54.14	4.24	Peak	201	151
3	5350.00	47.87	54.00	-6.13	43.44	4.43	Average	201	151
4	5350.00	60.10	74.00	-13.90	55.67	4.43	Peak	201	151
5	10480.00	56.73	68.20	-11.47	42.99	13.74	Peak	100	149
6	15720.00	44.38	54.00	-9.62	29.80	14.58	Average	100	153
7	15720.00	58.08	74.00	-15.92	43.50	14.58	Peak	100	153

Note 1: Emission Level (dBuV/m) = SA Reading (dBuV/m) + Factor* (dB)

*Factor includes antenna factor , cable loss and amplifier gain

Note 2: Margin (dB) = Emission level (dBuV/m) – Limit (dBuV/m).

Modulation	VHT20	Test Freq. (MHz)	5260
Polarization	Horizontal		

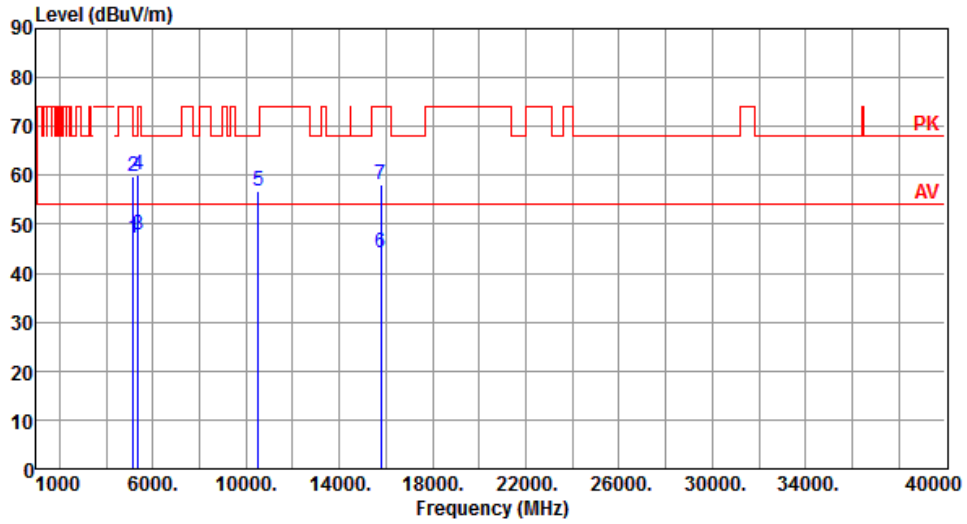

	Freq. MHz	Emission level dBuV/m	Limit dBuV/m	Margin dB	SA reading dBuV	Factor dB	Remark	ANT High cm	Turn Table deg
1	5150.00	47.19	54.00	-6.81	42.95	4.24	Average	182	94
2	5150.00	59.68	74.00	-14.32	55.44	4.24	Peak	182	94
3	5350.00	47.74	54.00	-6.26	43.31	4.43	Average	182	94
4	5350.00	60.08	74.00	-13.92	55.65	4.43	Peak	182	94
5	10520.00	56.66	68.20	-11.54	42.89	13.77	Peak	100	95
6	15780.00	44.09	54.00	-9.91	29.54	14.55	Average	100	87
7	15780.00	58.09	74.00	-15.91	43.54	14.55	Peak	100	87

Note 1: Emission Level (dBuV/m) = SA Reading (dBuV/m) + Factor* (dB)

*Factor includes antenna factor , cable loss and amplifier gain

Note 2: Margin (dB) = Emission level (dBuV/m) – Limit (dBuV/m).

Modulation	VHT20	Test Freq. (MHz)	5260
Polarization	Vertical		

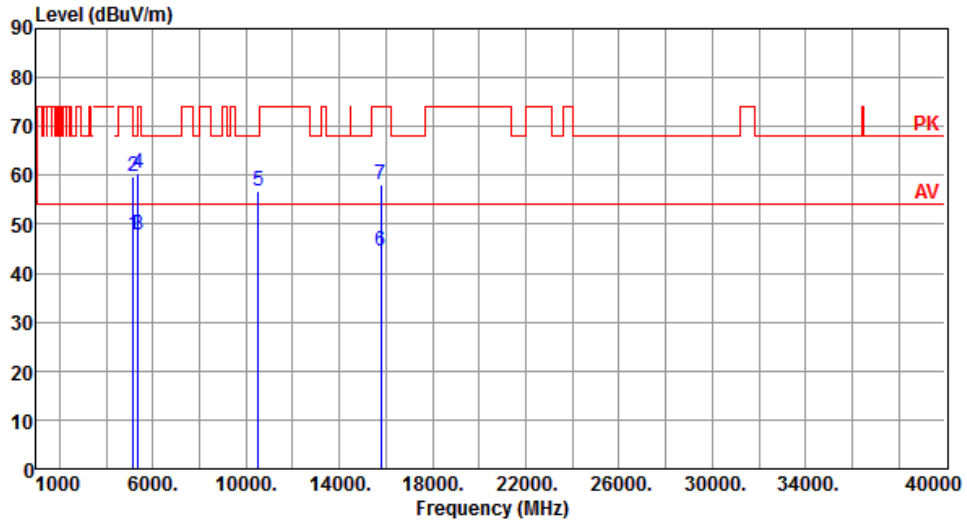

	Freq. MHz	Emission level dBuV/m	Limit dBuV/m	Margin dB	SA reading dBuV	Factor dB	Remark	ANT High cm	Turn Table deg
1	5150.00	47.78	54.00	-6.22	43.54	4.24	Average	226	147
2	5150.00	59.78	74.00	-14.22	55.54	4.24	Peak	226	147
3	5350.00	47.92	54.00	-6.08	43.49	4.43	Average	226	147
4	5350.00	60.40	74.00	-13.60	55.97	4.43	Peak	226	147
5	10520.00	56.76	68.20	-11.44	42.99	13.77	Peak	100	148
6	15780.00	44.49	54.00	-9.51	29.94	14.55	Average	100	157
7	15780.00	58.11	74.00	-15.89	43.56	14.55	Peak	100	157

Note 1: Emission Level (dBuV/m) = SA Reading (dBuV/m) + Factor* (dB)

*Factor includes antenna factor , cable loss and amplifier gain

Note 2: Margin (dB) = Emission level (dBuV/m) – Limit (dBuV/m).

Modulation	VHT20	Test Freq. (MHz)	5300
Polarization	Horizontal		

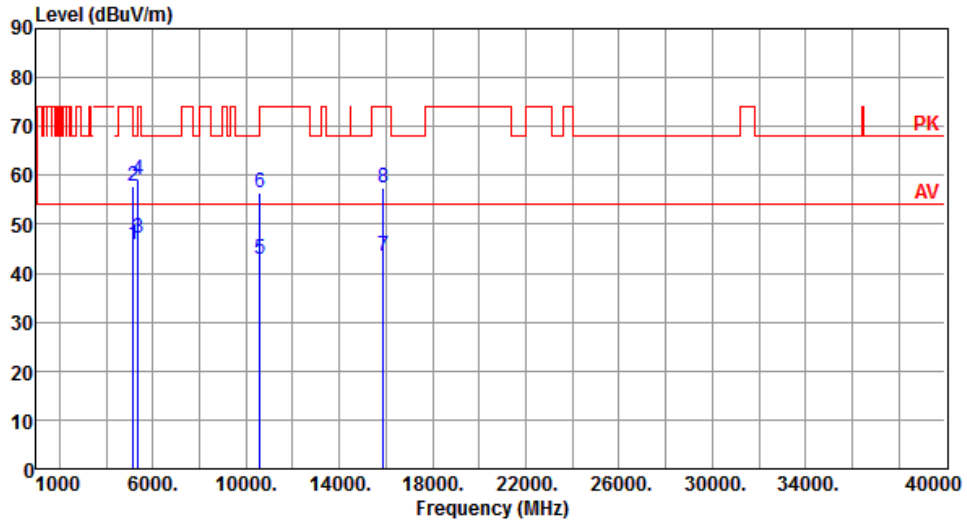

	Freq. MHz	Emission level dBuV/m	Limit dBuV/m	Margin dB	SA reading dBuV	Factor dB	Remark	ANT High cm	Turn Table deg
1	5150.00	45.74	54.00	-8.26	41.50	4.24	Average	175	102
2	5150.00	57.78	74.00	-16.22	53.54	4.24	Peak	175	102
3	5350.00	47.28	54.00	-6.72	42.85	4.43	Average	175	102
4	5350.00	59.08	74.00	-14.92	54.65	4.43	Peak	175	102
5	10600.00	42.71	54.00	-11.29	28.84	13.87	Average	100	98
6	10600.00	56.51	74.00	-17.49	42.64	13.87	Peak	100	98
7	15900.00	43.62	54.00	-10.38	29.14	14.48	Average	100	107
8	15900.00	57.62	74.00	-16.38	43.14	14.48	Peak	100	107

Note 1: Emission Level (dBuV/m) = SA Reading (dBuV/m) + Factor* (dB)

*Factor includes antenna factor , cable loss and amplifier gain

Note 2: Margin (dB) = Emission level (dBuV/m) – Limit (dBuV/m).

Modulation	VHT20	Test Freq. (MHz)	5300
Polarization	Vertical		

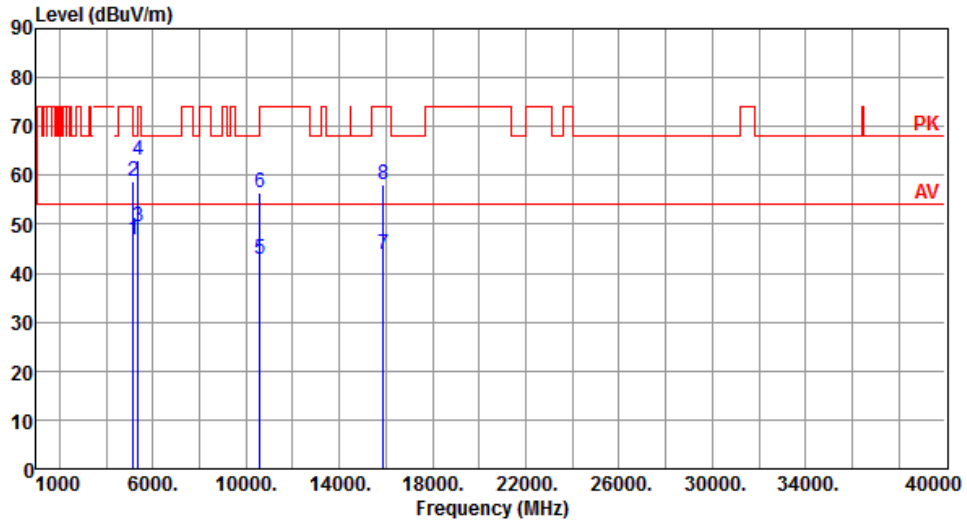

	Freq. MHz	Emission level dBuV/m	Limit dBuV/m	Margin dB	SA reading dBuV	Factor dB	Remark	ANT High cm	Turn Table deg
1	5150.00	46.84	54.00	-7.16	42.60	4.24	Average	190	146
2	5150.00	58.87	74.00	-15.13	54.63	4.24	Peak	190	146
3	5350.00	49.37	54.00	-4.63	44.94	4.43	Average	190	146
4	5350.00	63.22	74.00	-10.78	58.79	4.43	Peak	190	146
5	10600.00	42.78	54.00	-11.22	28.91	13.87	Average	100	154
6	10600.00	56.52	74.00	-17.48	42.65	13.87	Peak	100	154
7	15900.00	43.71	54.00	-10.29	29.23	14.48	Average	100	154
8	15900.00	58.02	74.00	-15.98	43.54	14.48	Peak	100	154

Note 1: Emission Level (dBuV/m) = SA Reading (dBuV/m) + Factor* (dB)

*Factor includes antenna factor , cable loss and amplifier gain

Note 2: Margin (dB) = Emission level (dBuV/m) – Limit (dBuV/m).

Modulation	VHT20	Test Freq. (MHz)	5320
Polarization	Horizontal		

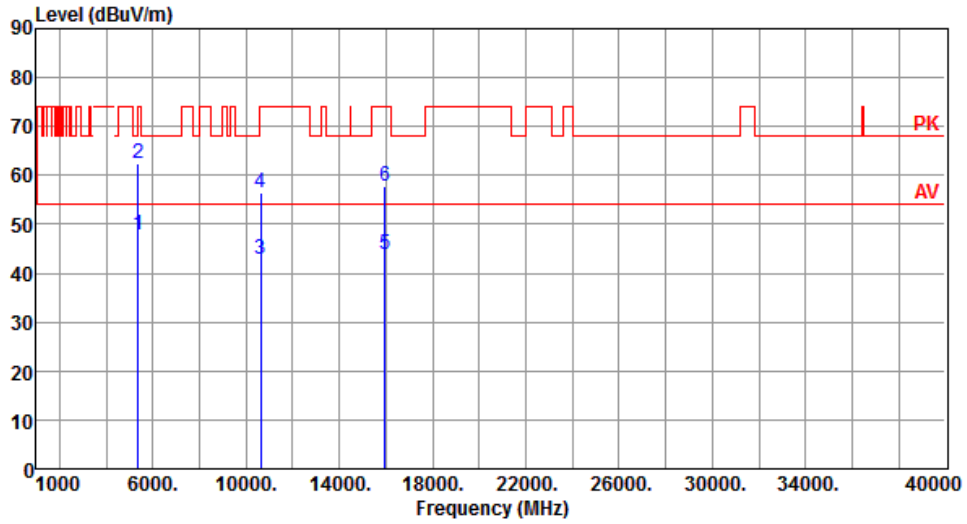

	Freq. MHz	Emission level dBuV/m	Limit dBuV/m	Margin dB	SA reading dBuV	Factor dB	Remark	ANT High cm	Turn Table deg
1	5350.00	47.67	54.00	-6.33	43.24	4.43	Average	195	88
2	5350.00	62.53	74.00	-11.47	58.10	4.43	Peak	195	88
3	10640.00	42.86	54.00	-11.14	28.94	13.92	Average	100	91
4	10640.00	56.56	74.00	-17.44	42.64	13.92	Peak	100	91
5	15960.00	43.84	54.00	-10.16	29.40	14.44	Average	100	95
6	15960.00	57.68	74.00	-16.32	43.24	14.44	Peak	100	95

Note 1: Emission Level (dBuV/m) = SA Reading (dBuV/m) + Factor* (dB)

*Factor includes antenna factor , cable loss and amplifier gain

Note 2: Margin (dB) = Emission level (dBuV/m) – Limit (dBuV/m).

Modulation	VHT20	Test Freq. (MHz)	5320
Polarization	Vertical		

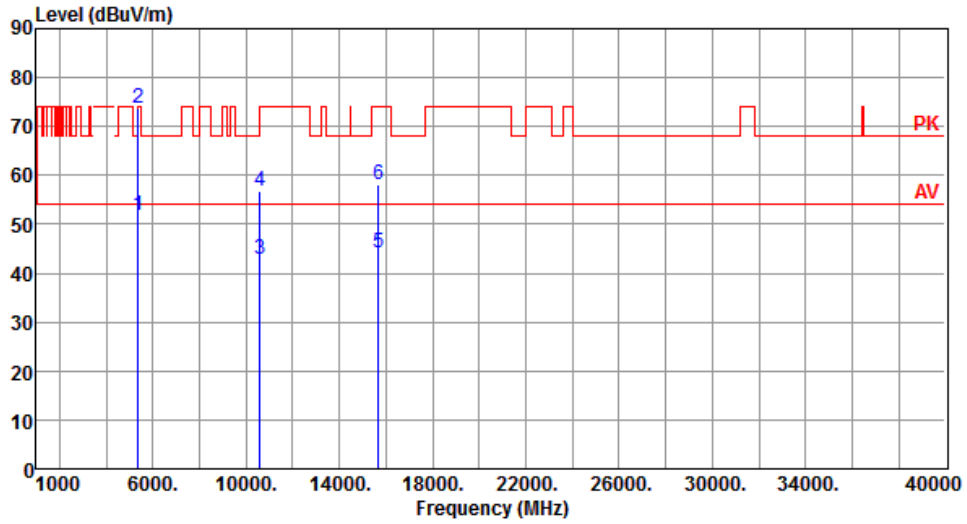

	Freq. MHz	Emission level dBuV/m	Limit dBuV/m	Margin dB	SA reading dBuV	Factor dB	Remark	ANT High cm	Turn Table deg
1	5350.00	51.92	54.00	-2.08	47.49	4.43	Average	213	147
2	5350.00	73.64	74.00	-0.36	69.21	4.43	Peak	213	147
3	10600.00	42.97	54.00	-11.03	29.10	13.87	Average	100	153
4	10600.00	56.68	74.00	-17.32	42.81	13.87	Peak	100	153
5	15690.00	44.07	54.00	-9.93	29.48	14.59	Average	100	155
6	15690.00	58.16	74.00	-15.84	43.57	14.59	Peak	100	155

Note 1: Emission Level (dBuV/m) = SA Reading (dBuV/m) + Factor* (dB)

*Factor includes antenna factor , cable loss and amplifier gain

Note 2: Margin (dB) = Emission level (dBuV/m) – Limit (dBuV/m).

Modulation	VHT20	Test Freq. (MHz)	5500
Polarization	Horizontal		

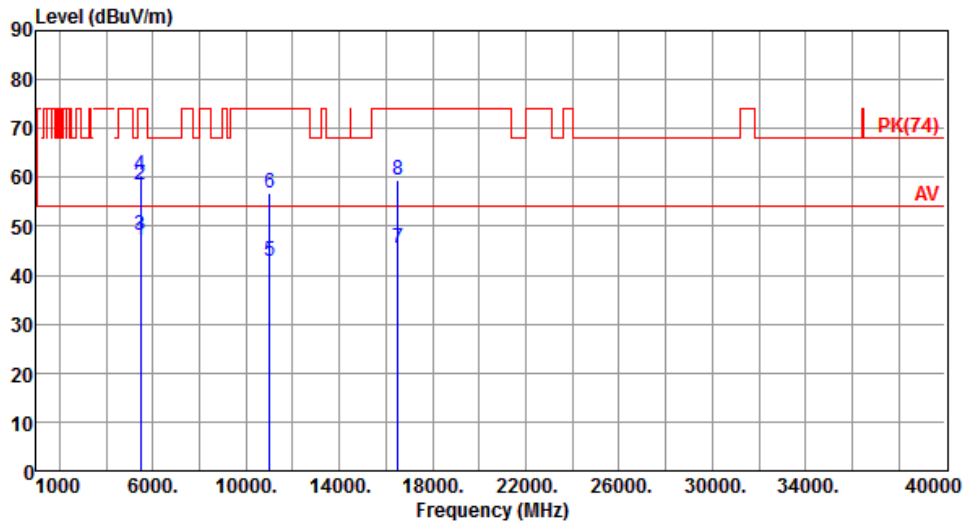

	Freq. MHz	Emission level dBuV/m	Limit dBuV/m	Margin dB	SA reading dBuV	Factor dB	Remark	ANT High cm	Turn Table deg
1	5460.00	47.15	54.00	-6.85	42.64	4.51	Average	178	96
2	5460.00	58.51	74.00	-15.49	54.00	4.51	Peak	178	96
3	5470.00	48.15	54.00	-5.85	43.63	4.52	Average	178	96
4	5470.00	60.49	74.00	-13.51	55.97	4.52	Peak	178	96
5	11000.00	42.78	54.00	-11.22	28.44	14.34	Average	100	95
6	11000.00	56.91	74.00	-17.09	42.57	14.34	Peak	100	95
7	16500.00	45.48	54.00	-8.52	29.00	16.48	Average	100	105
8	16500.00	59.37	74.00	-14.63	42.89	16.48	Peak	100	105

Note 1: Emission Level (dBuV/m) = SA Reading (dBuV/m) + Factor* (dB)

*Factor includes antenna factor , cable loss and amplifier gain

Note 2: Margin (dB) = Emission level (dBuV/m) – Limit (dBuV/m).

Modulation	VHT20	Test Freq. (MHz)	5500
Polarization	Vertical		

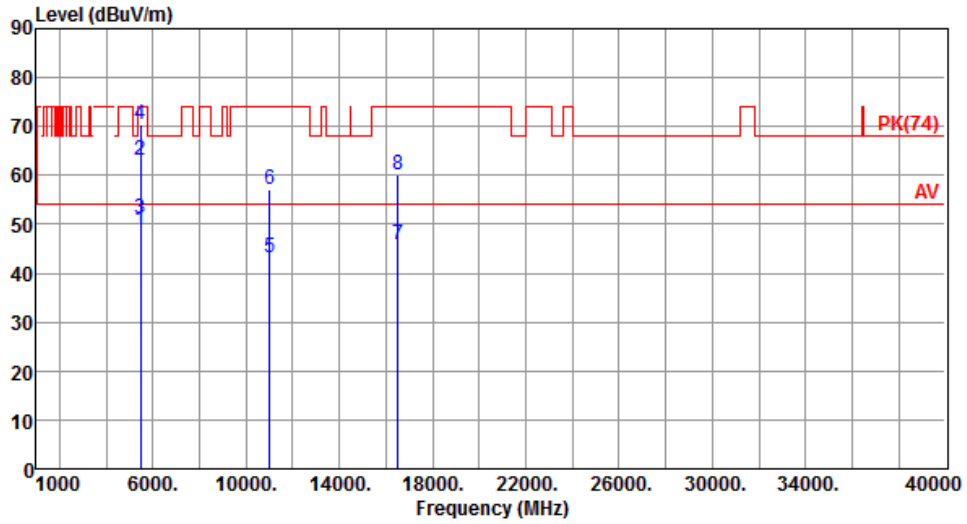

	Freq. MHz	Emission level dBuV/m	Limit dBuV/m	Margin dB	SA reading dBuV	Factor dB	Remark	ANT High cm	Turn Table deg
1	5460.00	48.74	54.00	-5.26	44.23	4.51	Average	179	146
2	5460.00	63.11	74.00	-10.89	58.60	4.51	Peak	179	146
3	5470.00	51.16	54.00	-2.84	46.64	4.52	Average	179	146
4	5470.00	70.56	74.00	-3.44	66.04	4.52	Peak	179	146
5	11000.00	43.28	54.00	-10.72	28.94	14.34	Average	100	154
6	11000.00	56.98	74.00	-17.02	42.64	14.34	Peak	100	154
7	16500.00	45.82	54.00	-8.18	29.34	16.48	Average	100	157
8	16500.00	60.02	74.00	-13.98	43.54	16.48	Peak	100	157

Note 1: Emission Level (dBuV/m) = SA Reading (dBuV/m) + Factor* (dB)

*Factor includes antenna factor , cable loss and amplifier gain

Note 2: Margin (dB) = Emission level (dBuV/m) – Limit (dBuV/m).

Modulation	VHT20	Test Freq. (MHz)	5580
Polarization	Horizontal		

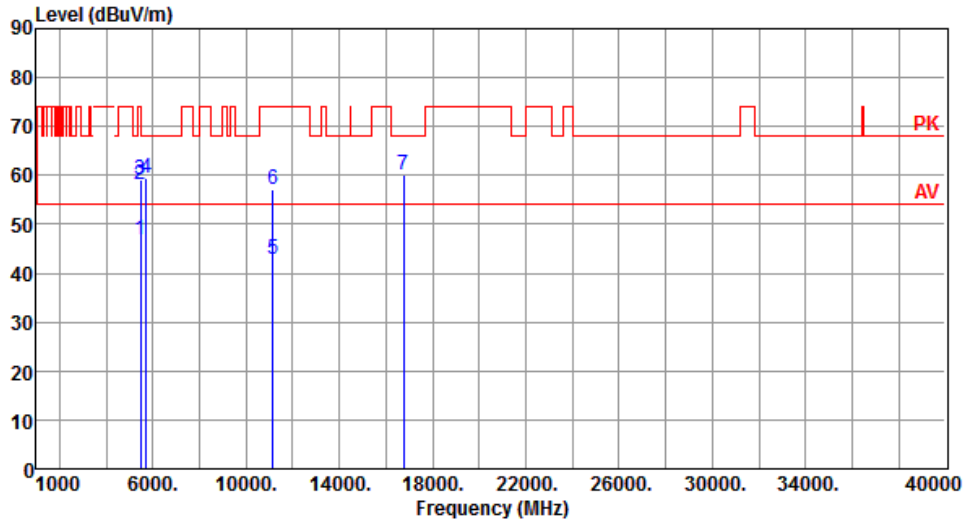

	Freq. MHz	Emission level dBuV/m	Limit dBuV/m	Margin dB	SA reading dBuV	Factor dB	Remark	ANT High cm	Turn Table deg
1	5460.00	46.95	54.00	-7.05	42.44	4.51	Average	182	101
2	5460.00	58.10	74.00	-15.90	53.59	4.51	Peak	182	101
3	5470.00	59.19	68.20	-9.01	54.67	4.52	Peak	182	101
4	5725.00	59.48	68.20	-8.72	54.66	4.82	Peak	182	101
5	11160.00	42.84	54.00	-11.16	28.64	14.20	Average	100	106
6	11160.00	57.09	74.00	-16.91	42.89	14.20	Peak	100	106
7	16740.00	60.02	68.20	-8.18	43.10	16.92	Peak	100	99

Note 1: Emission Level (dBuV/m) = SA Reading (dBuV/m) + Factor* (dB)

*Factor includes antenna factor , cable loss and amplifier gain

Note 2: Margin (dB) = Emission level (dBuV/m) – Limit (dBuV/m).

Modulation	VHT20	Test Freq. (MHz)	5580
Polarization	Vertical		

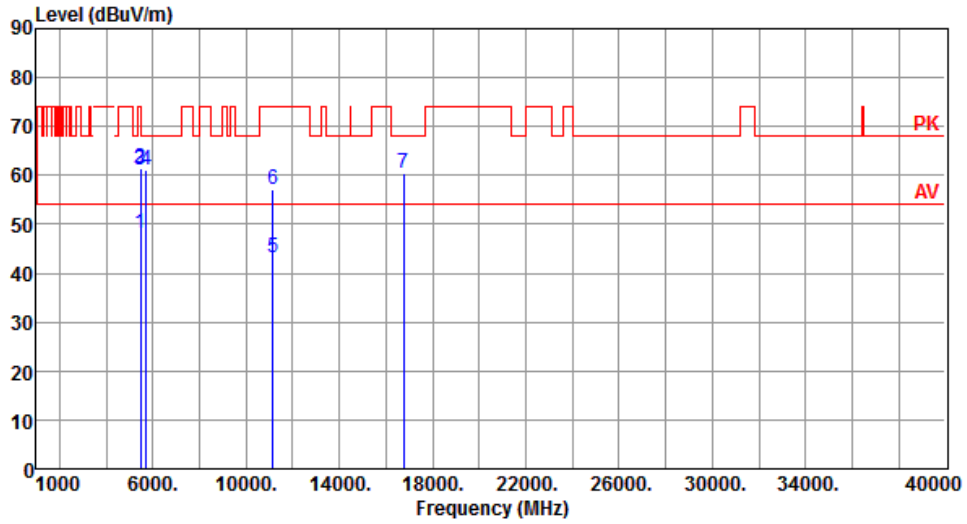

	Freq. MHz	Emission level dBuV/m	Limit dBuV/m	Margin dB	SA reading dBuV	Factor dB	Remark	ANT High cm	Turn Table deg
1	5460.00	48.10	54.00	-5.90	43.59	4.51	Average	174	144
2	5460.00	61.36	74.00	-12.64	56.85	4.51	Peak	174	144
3	5470.00	61.13	68.20	-7.07	56.61	4.52	Peak	174	144
4	5725.00	61.22	68.20	-6.98	56.40	4.82	Peak	174	144
5	11160.00	43.30	54.00	-10.70	29.10	14.20	Average	100	148
6	11160.00	57.09	74.00	-16.91	42.89	14.20	Peak	100	148
7	16740.00	60.50	68.20	-7.70	43.58	16.92	Peak	100	152

Note 1: Emission Level (dBuV/m) = SA Reading (dBuV/m) + Factor* (dB)

*Factor includes antenna factor , cable loss and amplifier gain

Note 2: Margin (dB) = Emission level (dBuV/m) – Limit (dBuV/m).

Modulation	VHT20	Test Freq. (MHz)	5700
Polarization	Horizontal		

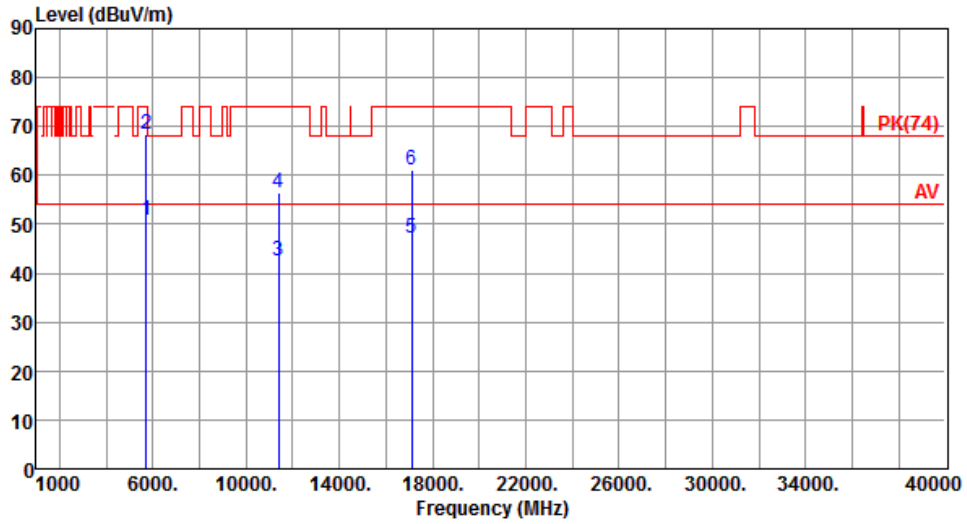

	Freq. MHz	Emission level dBuV/m	Limit dBuV/m	Margin dB	SA reading dBuV	Factor dB	Remark	ANT High cm	Turn Table deg
1	5725.00	50.72	54.00	-3.28	45.90	4.82	Average	193	147
2	5725.00	68.33	74.00	-5.67	63.51	4.82	Peak	193	147
3	11400.00	42.64	54.00	-11.36	28.64	14.00	Average	100	153
4	11400.00	56.60	74.00	-17.40	42.60	14.00	Peak	100	153
5	17100.00	47.22	54.00	-6.78	29.55	17.67	Average	100	159
6	17100.00	61.00	74.00	-13.00	43.33	17.67	Peak	100	159

Note 1: Emission Level (dBuV/m) = SA Reading (dBuV/m) + Factor* (dB)

*Factor includes antenna factor , cable loss and amplifier gain

Note 2: Margin (dB) = Emission level (dBuV/m) – Limit (dBuV/m).

Modulation	VHT20	Test Freq. (MHz)	5700
Polarization	Vertical		

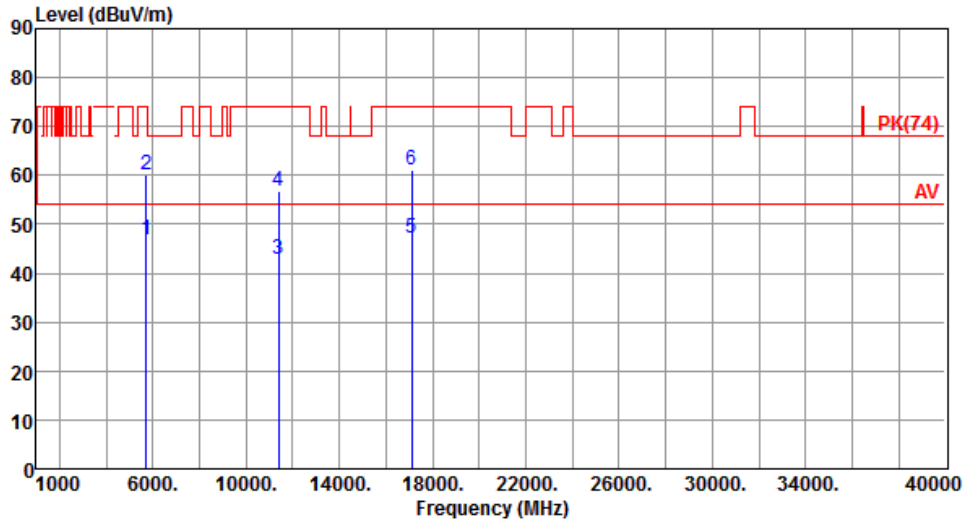

	Freq. MHz	Emission level dBuV/m	Limit dBuV/m	Margin dB	SA reading dBuV	Factor dB	Remark	ANT High cm	Turn Table deg
1	5725.00	46.85	54.00	-7.15	42.03	4.82	Average	193	94
2	5725.00	59.97	74.00	-14.03	55.15	4.82	Peak	193	94
3	11400.00	42.68	54.00	-11.32	28.68	14.00	Average	100	96
4	11400.00	56.65	74.00	-17.35	42.65	14.00	Peak	100	96
5	17100.00	47.00	54.00	-7.00	29.33	17.67	Average	100	110
6	17100.00	61.23	74.00	-12.77	43.56	17.67	Peak	100	110

Note 1: Emission Level (dBuV/m) = SA Reading (dBuV/m) + Factor* (dB)

*Factor includes antenna factor , cable loss and amplifier gain

Note 2: Margin (dB) = Emission level (dBuV/m) – Limit (dBuV/m).

Modulation	VHT20	Test Freq. (MHz)	5720
Polarization	Horizontal		

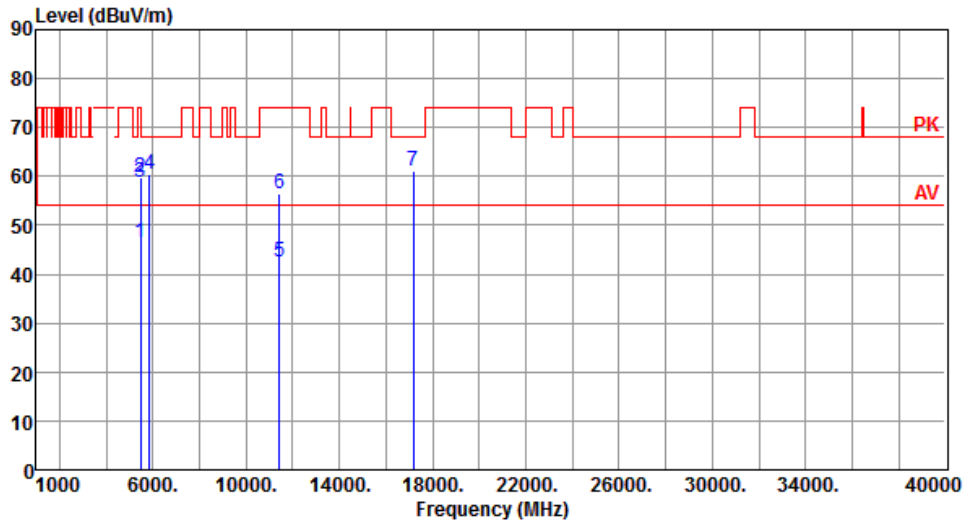

	Freq. MHz	Emission level dBuV/m	Limit dBuV/m	Margin dB	SA reading dBuV	Factor dB	Remark	ANT High cm	Turn Table deg
1	5460.00	46.35	54.00	-7.65	41.84	4.51	Average	216	97
2	5460.00	59.83	74.00	-14.17	55.32	4.51	Peak	216	97
3	5470.00	58.84	68.20	-9.36	54.32	4.52	Peak	216	97
4	5850.00	60.60	68.20	-7.60	55.61	4.99	Peak	216	97
5	11440.00	42.64	54.00	-11.36	28.68	13.96	Average	100	999
6	11440.00	56.56	74.00	-17.44	42.60	13.96	Peak	100	999
7	17160.00	61.04	68.20	-7.16	43.21	17.83	Peak	100	999

Note 1: Emission Level (dBuV/m) = SA Reading (dBuV/m) + Factor* (dB)

*Factor includes antenna factor , cable loss and amplifier gain

Note 2: Margin (dB) = Emission level (dBuV/m) – Limit (dBuV/m).

Modulation	VHT20	Test Freq. (MHz)	5720
-------------------	-------	-------------------------	------

Polarization	Vertical
---------------------	----------

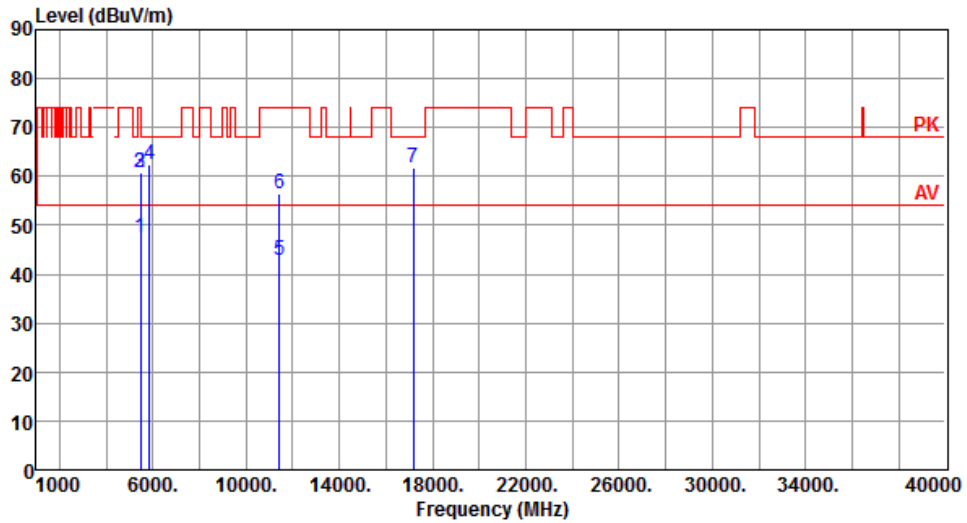

	Freq. MHz	Emission level dBuV/m	Limit dBuV/m	Margin dB	SA reading dBuV	Factor dB	Remark	ANT High cm	Turn Table deg
1	5460.00	47.64	54.00	-6.36	43.13	4.51	Average	171	148
2	5460.00	60.80	74.00	-13.20	56.29	4.51	Peak	171	148
3	5470.00	60.77	68.20	-7.43	56.25	4.52	Peak	171	148
4	5850.00	62.51	68.20	-5.69	57.52	4.99	Peak	171	148
5	11440.00	42.90	54.00	-11.10	28.94	13.96	Average	100	159
6	11440.00	56.56	74.00	-17.44	42.60	13.96	Peak	100	159
7	17160.00	61.64	68.20	-6.56	43.81	17.83	Peak	100	154

Note 1: Emission Level (dBuV/m) = SA Reading (dBuV/m) + Factor* (dB)

*Factor includes antenna factor , cable loss and amplifier gain

Note 2: Margin (dB) = Emission level (dBuV/m) – Limit (dBuV/m).

Modulation	VHT20	Test Freq. (MHz)	5745
Polarization	Horizontal		

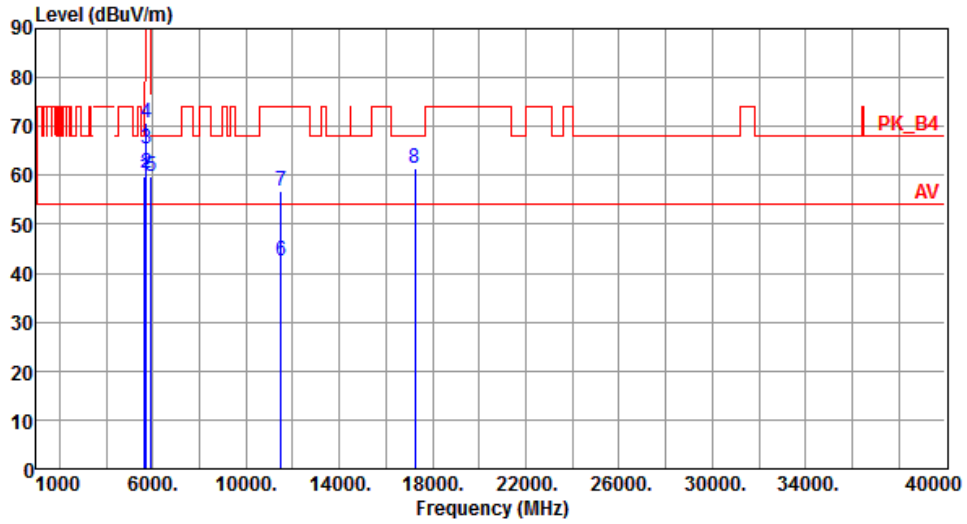

	Freq. MHz	Emission level dBuV/m	Limit dBuV/m	Margin dB	SA reading dBuV	Factor dB	Remark	ANT High cm	Turn Table deg
1	5650.00	59.92	68.20	-8.28	55.19	4.73	Peak	220	104
2	5700.00	60.46	105.20	-44.74	55.67	4.79	Peak	220	104
3	5720.00	65.30	110.80	-45.50	60.48	4.82	Peak	220	104
4	5725.00	70.74	122.20	-51.46	65.92	4.82	Peak	220	104
5	5925.00	59.78	68.20	-8.42	54.70	5.08	Peak	220	104
6	11490.00	42.61	54.00	-11.39	28.69	13.92	Average	100	106
7	11490.00	56.89	74.00	-17.11	42.97	13.92	Peak	100	106
8	17235.00	61.58	68.20	-6.62	43.55	18.03	Peak	100	98

Note 1: Emission Level (dBuV/m) = SA Reading (dBuV/m) + Factor* (dB)

*Factor includes antenna factor , cable loss and amplifier gain

Note 2: Margin (dB) = Emission level (dBuV/m) – Limit (dBuV/m).

Modulation	VHT20	Test Freq. (MHz)	5745
Polarization	Vertical		

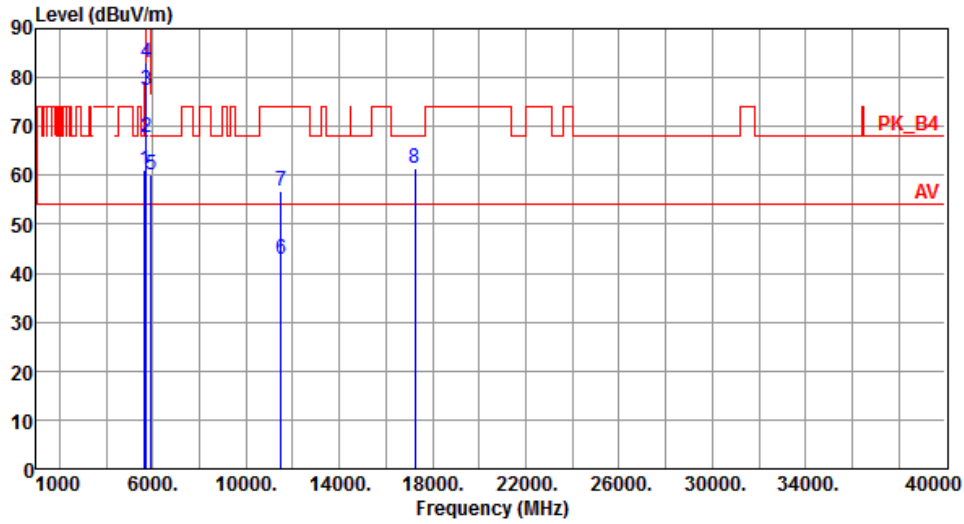

	Freq. MHz	Emission level dBuV/m	Limit dBuV/m	Margin dB	SA reading dBuV	Factor dB	Remark	ANT High cm	Turn Table deg
1	5650.00	61.24	68.20	-6.96	56.51	4.73	Peak	173	148
2	5700.00	67.88	105.20	-37.32	63.09	4.79	Peak	173	148
3	5720.00	77.37	110.80	-33.43	72.55	4.82	Peak	173	148
4	5725.00	83.03	122.20	-39.17	78.21	4.82	Peak	173	148
5	5925.00	59.96	68.20	-8.24	54.88	5.08	Peak	173	148
6	11490.00	42.80	54.00	-11.20	28.88	13.92	Average	100	147
7	11490.00	56.91	74.00	-17.09	42.99	13.92	Peak	100	147
8	17235.00	61.57	68.20	-6.63	43.54	18.03	Peak	100	153

Note 1: Emission Level (dBuV/m) = SA Reading (dBuV/m) + Factor* (dB)

*Factor includes antenna factor , cable loss and amplifier gain

Note 2: Margin (dB) = Emission level (dBuV/m) – Limit (dBuV/m).

Modulation	VHT20	Test Freq. (MHz)	5785
Polarization	Horizontal		

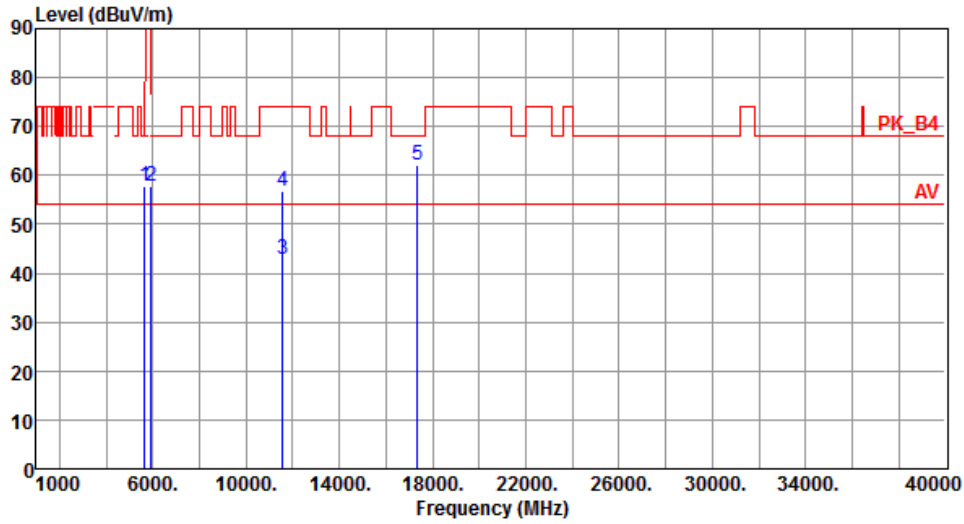

	Freq. MHz	Emission level dBuV/m	Limit dBuV/m	Margin dB	SA reading dBuV	Factor dB	Remark	ANT High cm	Turn Table deg
1	5650.00	57.82	68.20	-10.38	53.09	4.73	Peak	219	103
2	5925.00	57.73	68.20	-10.47	52.65	5.08	Peak	219	103
3	11570.00	42.78	54.00	-11.22	28.95	13.83	Average	100	95
4	11570.00	56.71	74.00	-17.29	42.88	13.83	Peak	100	95
5	17355.00	62.04	68.20	-6.16	43.68	18.36	Peak	100	99

Note 1: Emission Level (dBuV/m) = SA Reading (dBuV/m) + Factor* (dB)

*Factor includes antenna factor , cable loss and amplifier gain

Note 2: Margin (dB) = Emission level (dBuV/m) – Limit (dBuV/m).

Modulation	VHT20	Test Freq. (MHz)	5785
Polarization	Vertical		

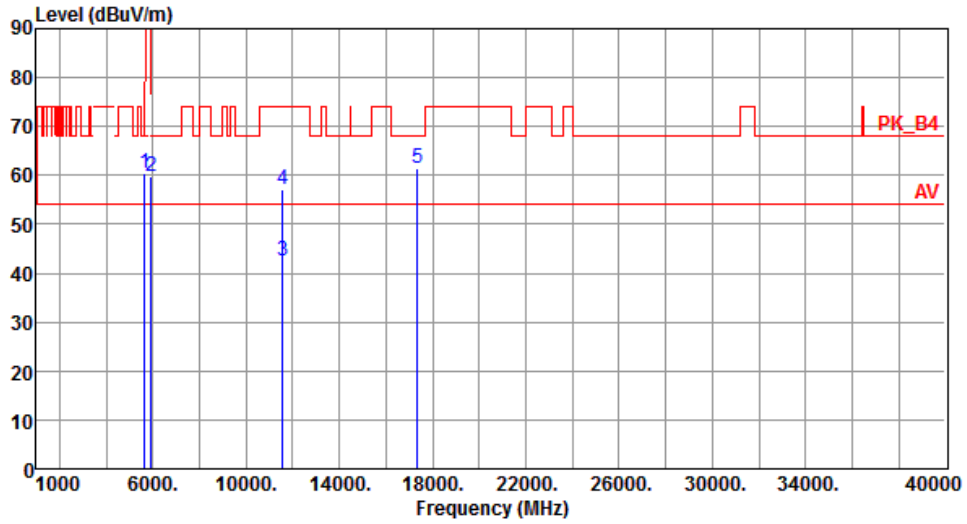

	Freq. MHz	Emission level dBuV/m	Limit dBuV/m	Margin dB	SA reading dBuV	Factor dB	Remark	ANT High cm	Turn Table deg
1	5650.00	60.38	68.20	-7.82	55.65	4.73	Peak	169	146
2	5925.00	59.79	68.20	-8.41	54.71	5.08	Peak	169	146
3	11570.00	42.67	54.00	-11.33	28.84	13.83	Average	100	156
4	11570.00	57.23	74.00	-16.77	43.40	13.83	Peak	100	156
5	17355.00	61.38	68.20	-6.82	43.02	18.36	Peak	100	152

Note 1: Emission Level (dBuV/m) = SA Reading (dBuV/m) + Factor* (dB)

*Factor includes antenna factor , cable loss and amplifier gain

Note 2: Margin (dB) = Emission level (dBuV/m) – Limit (dBuV/m).

Modulation	VHT20	Test Freq. (MHz)	5825
Polarization	Horizontal		

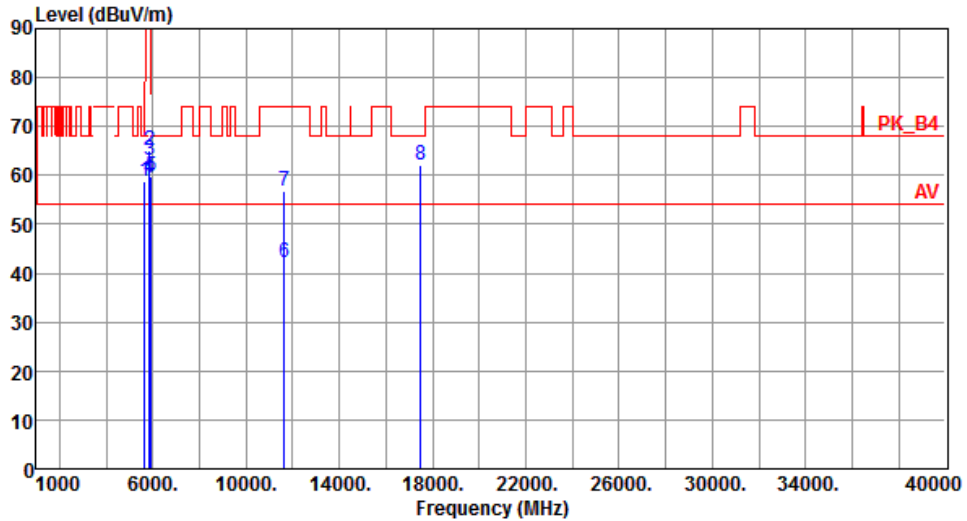

	Freq. MHz	Emission level dBuV/m	Limit dBuV/m	Margin dB	SA reading dBuV	Factor dB	Remark	ANT High cm	Turn Table deg
1	5650.00	58.93	68.20	-9.27	54.20	4.73	Peak	188	97
2	5850.00	65.09	122.20	-57.11	60.10	4.99	Peak	188	97
3	5855.00	63.23	110.80	-47.57	58.23	5.00	Peak	188	97
4	5875.00	59.43	105.20	-45.77	54.41	5.02	Peak	188	97
5	5925.00	59.92	68.20	-8.28	54.84	5.08	Peak	188	97
6	11650.00	42.05	54.00	-11.95	28.31	13.74	Average	100	105
7	11650.00	56.63	74.00	-17.37	42.89	13.74	Peak	100	105
8	17475.00	62.23	68.20	-5.97	43.54	18.69	Peak	100	103

Note 1: Emission Level (dBuV/m) = SA Reading (dBuV/m) + Factor* (dB)

*Factor includes antenna factor , cable loss and amplifier gain

Note 2: Margin (dB) = Emission level (dBuV/m) – Limit (dBuV/m).

Modulation	VHT20	Test Freq. (MHz)	5825
Polarization	Vertical		

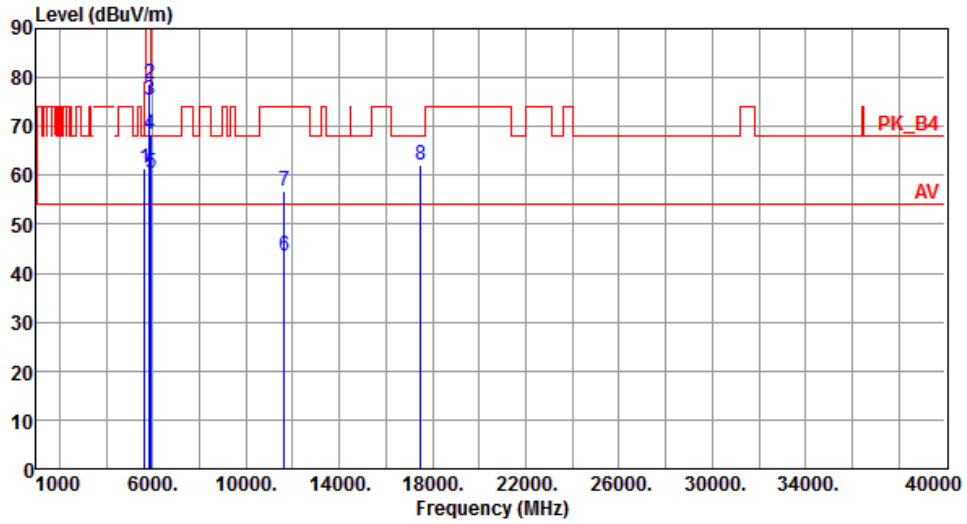

	Freq. MHz	Emission level dBuV/m	Limit dBuV/m	Margin dB	SA reading dBuV	Factor dB	Remark	ANT High cm	Turn Table deg
1	5650.00	61.41	68.20	-6.79	56.68	4.73	Peak	190	150
2	5850.00	78.64	122.20	-43.56	73.65	4.99	Peak	190	150
3	5855.00	75.47	110.80	-35.33	70.47	5.00	Peak	190	150
4	5875.00	68.45	105.20	-36.75	63.43	5.02	Peak	190	150
5	5925.00	60.47	68.20	-7.73	55.39	5.08	Peak	190	150
6	11650.00	43.38	54.00	-10.62	29.64	13.74	Average	100	141
7	11650.00	56.88	74.00	-17.12	43.14	13.74	Peak	100	141
8	17475.00	62.12	68.20	-6.08	43.43	18.69	Peak	100	158

Note 1: Emission Level (dBuV/m) = SA Reading (dBuV/m) + Factor* (dB)

*Factor includes antenna factor , cable loss and amplifier gain

Note 2: Margin (dB) = Emission level (dBuV/m) – Limit (dBuV/m).

3.5.7 Transmitter Radiated Unwanted Emissions (Above 1GHz) for VHT40

Modulation	VHT40	Test Freq. (MHz)	5190																																																																									
Polarization	Horizontal																																																																											
	<table border="1"> <thead> <tr> <th>Freq.</th> <th>Emission level</th> <th>Limit</th> <th>Margin</th> <th>SA reading</th> <th>Factor</th> <th>Remark</th> <th>ANT High</th> <th>Turn Table</th> </tr> <tr> <th>MHz</th> <th>dBuV/m</th> <th>dBuV/m</th> <th>dB</th> <th>dBuV</th> <th>dB</th> <th></th> <th>cm</th> <th>deg</th> </tr> </thead> <tbody> <tr> <td>1</td> <td>5150.00</td> <td>46.65</td> <td>54.00</td> <td>-7.35</td> <td>42.41</td> <td>4.24</td> <td>Average</td> <td>163</td> <td>88</td> </tr> <tr> <td>2</td> <td>5150.00</td> <td>57.24</td> <td>74.00</td> <td>-16.76</td> <td>53.00</td> <td>4.24</td> <td>Peak</td> <td>163</td> <td>88</td> </tr> <tr> <td>3</td> <td>10380.00</td> <td>56.40</td> <td>68.20</td> <td>-11.80</td> <td>42.70</td> <td>13.70</td> <td>Peak</td> <td>100</td> <td>95</td> </tr> <tr> <td>4</td> <td>15570.00</td> <td>43.78</td> <td>54.00</td> <td>-10.22</td> <td>29.12</td> <td>14.66</td> <td>Average</td> <td>100</td> <td>91</td> </tr> <tr> <td>5</td> <td>15570.00</td> <td>58.07</td> <td>74.00</td> <td>-15.93</td> <td>43.41</td> <td>14.66</td> <td>Peak</td> <td>100</td> <td>91</td> </tr> </tbody> </table>	Freq.	Emission level	Limit	Margin	SA reading	Factor	Remark	ANT High	Turn Table	MHz	dBuV/m	dBuV/m	dB	dBuV	dB		cm	deg	1	5150.00	46.65	54.00	-7.35	42.41	4.24	Average	163	88	2	5150.00	57.24	74.00	-16.76	53.00	4.24	Peak	163	88	3	10380.00	56.40	68.20	-11.80	42.70	13.70	Peak	100	95	4	15570.00	43.78	54.00	-10.22	29.12	14.66	Average	100	91	5	15570.00	58.07	74.00	-15.93	43.41	14.66	Peak	100	91							
Freq.	Emission level	Limit	Margin	SA reading	Factor	Remark	ANT High	Turn Table																																																																				
MHz	dBuV/m	dBuV/m	dB	dBuV	dB		cm	deg																																																																				
1	5150.00	46.65	54.00	-7.35	42.41	4.24	Average	163	88																																																																			
2	5150.00	57.24	74.00	-16.76	53.00	4.24	Peak	163	88																																																																			
3	10380.00	56.40	68.20	-11.80	42.70	13.70	Peak	100	95																																																																			
4	15570.00	43.78	54.00	-10.22	29.12	14.66	Average	100	91																																																																			
5	15570.00	58.07	74.00	-15.93	43.41	14.66	Peak	100	91																																																																			
<p>Note 1: Emission Level (dBuV/m) = SA Reading (dBuV/m) + Factor* (dB) *Factor includes antenna factor , cable loss and amplifier gain Note 2: Margin (dB) = Emission level (dBuV/m) – Limit (dBuV/m).</p>																																																																												

Modulation	VHT40	Test Freq. (MHz)	5190
Polarization	Vertical		

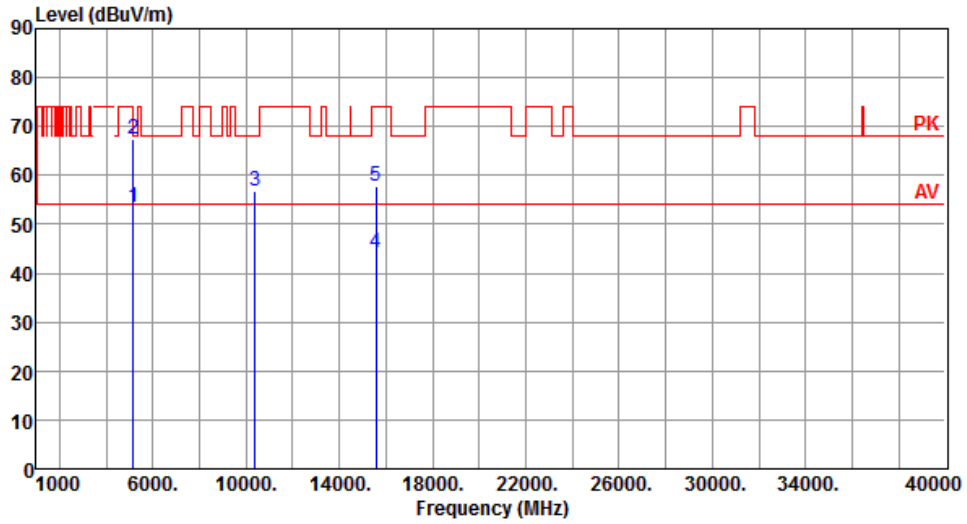

	Freq. MHz	Emission level dBuV/m	Limit dBuV/m	Margin dB	SA reading dBuV	Factor dB	Remark	ANT High cm	Turn Table deg
1	5150.00	53.62	54.00	-0.38	49.38	4.24	Average	197	99
2	5150.00	67.34	74.00	-6.66	63.10	4.24	Peak	197	99
3	10380.00	56.64	68.20	-11.56	42.94	13.70	Peak	100	171
4	15570.00	44.08	54.00	-9.92	29.42	14.66	Average	100	164
5	15570.00	57.84	74.00	-16.16	43.18	14.66	Peak	100	164

Note 1: Emission Level (dBuV/m) = SA Reading (dBuV/m) + Factor* (dB)

*Factor includes antenna factor , cable loss and amplifier gain

Note 2: Margin (dB) = Emission level (dBuV/m) – Limit (dBuV/m).

Modulation	VHT40	Test Freq. (MHz)	5230
Polarization	Horizontal		

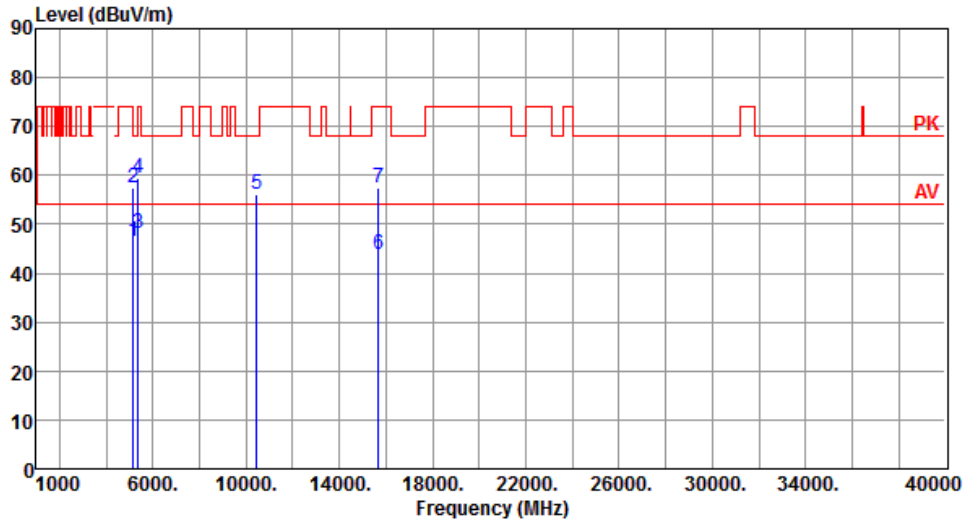

	Freq. MHz	Emission level dBuV/m	Limit dBuV/m	Margin dB	SA reading dBuV	Factor dB	Remark	ANT High cm	Turn Table deg
1	5150.00	46.53	54.00	-7.47	42.29	4.24	Average	184	117
2	5150.00	57.45	74.00	-16.55	53.21	4.24	Peak	184	117
3	5350.00	48.28	54.00	-5.72	43.85	4.43	Average	184	117
4	5350.00	59.53	74.00	-14.47	55.10	4.43	Peak	184	117
5	10460.00	56.24	68.20	-11.96	42.51	13.73	Peak	100	108
6	15690.00	43.81	54.00	-10.19	29.22	14.59	Average	100	101
7	15690.00	57.60	74.00	-16.40	43.01	14.59	Peak	100	101

Note 1: Emission Level (dBuV/m) = SA Reading (dBuV/m) + Factor* (dB)

*Factor includes antenna factor , cable loss and amplifier gain

Note 2: Margin (dB) = Emission level (dBuV/m) – Limit (dBuV/m).

Modulation	VHT40	Test Freq. (MHz)	5230
Polarization	Vertical		

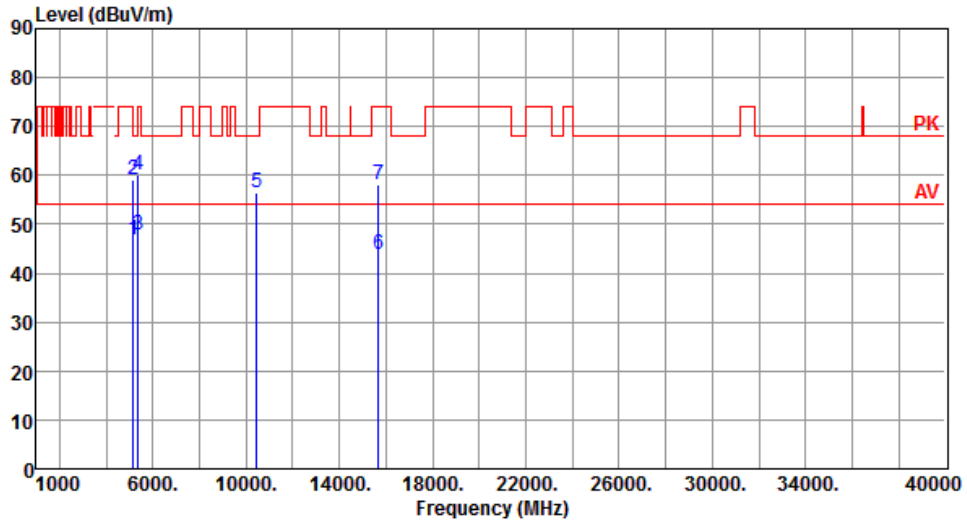

	Freq. MHz	Emission level dBuV/m	Limit dBuV/m	Margin dB	SA reading dBuV	Factor dB	Remark	ANT High cm	Turn Table deg
1	5150.00	46.80	54.00	-7.20	42.56	4.24	Average	206	139
2	5150.00	58.98	74.00	-15.02	54.74	4.24	Peak	206	139
3	5350.00	47.97	54.00	-6.03	43.54	4.43	Average	206	139
4	5350.00	60.06	74.00	-13.94	55.63	4.43	Peak	206	139
5	10460.00	56.44	68.20	-11.76	42.71	13.73	Peak	100	145
6	15690.00	43.91	54.00	-10.09	29.32	14.59	Average	100	147
7	15690.00	58.17	74.00	-15.83	43.58	14.59	Peak	100	147

Note 1: Emission Level (dBuV/m) = SA Reading (dBuV/m) + Factor* (dB)

*Factor includes antenna factor , cable loss and amplifier gain

Note 2: Margin (dB) = Emission level (dBuV/m) – Limit (dBuV/m).

Modulation	VHT40	Test Freq. (MHz)	5270
Polarization	Horizontal		

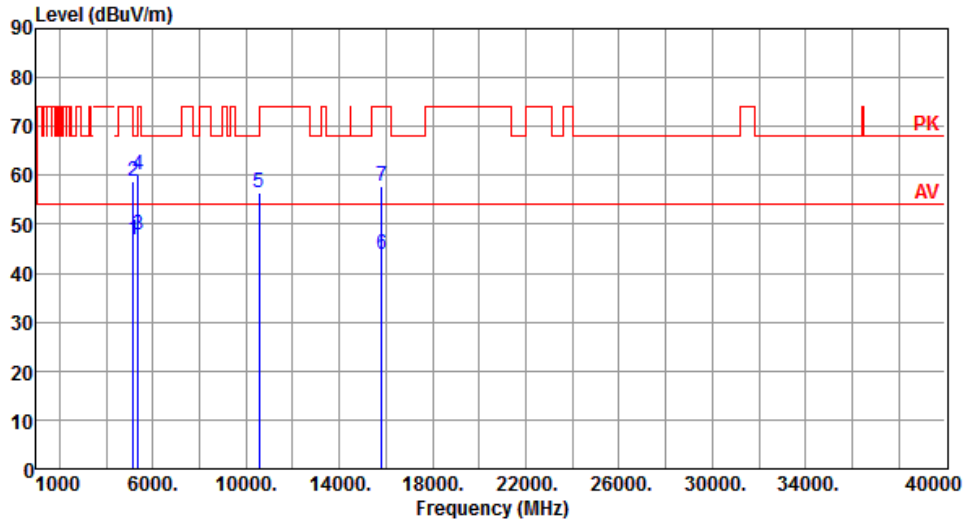

	Freq. MHz	Emission level dBuV/m	Limit dBuV/m	Margin dB	SA reading dBuV	Factor dB	Remark	ANT High cm	Turn Table deg
1	5150.00	46.81	54.00	-7.19	42.57	4.24	Average	183	93
2	5150.00	58.88	74.00	-15.12	54.64	4.24	Peak	183	93
3	5350.00	47.67	54.00	-6.33	43.24	4.43	Average	183	93
4	5350.00	60.13	74.00	-13.87	55.70	4.43	Peak	183	93
5	10540.00	56.48	68.20	-11.72	42.68	13.80	Peak	100	95
6	15810.00	43.84	54.00	-10.16	29.30	14.54	Average	100	87
7	15810.00	57.78	74.00	-16.22	43.24	14.54	Peak	100	87

Note 1: Emission Level (dBuV/m) = SA Reading (dBuV/m) + Factor* (dB)

*Factor includes antenna factor , cable loss and amplifier gain

Note 2: Margin (dB) = Emission level (dBuV/m) – Limit (dBuV/m).

Modulation	VHT40	Test Freq. (MHz)	5270
Polarization	Vertical		

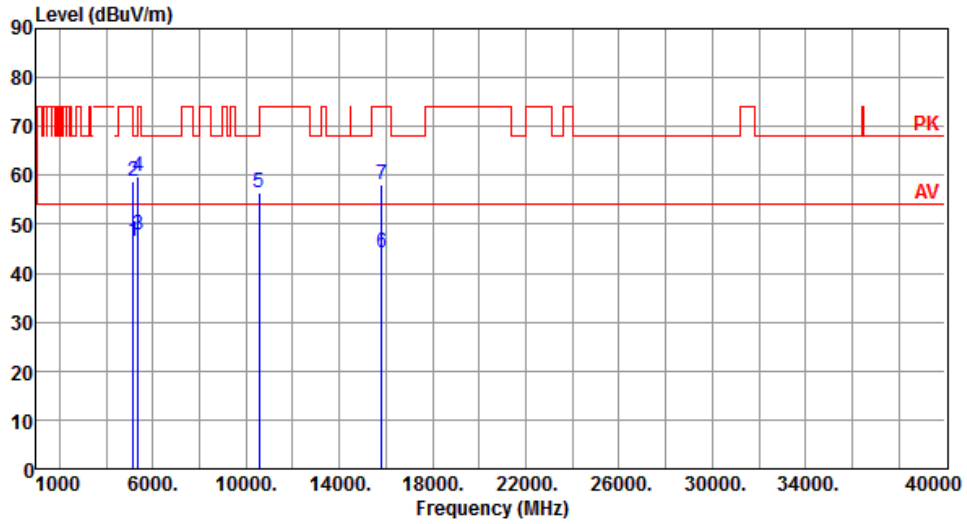

	Freq. MHz	Emission level dBuV/m	Limit dBuV/m	Margin dB	SA reading dBuV	Factor dB	Remark	ANT High cm	Turn Table deg
1	5150.00	46.46	54.00	-7.54	42.22	4.24	Average	210	153
2	5150.00	58.88	74.00	-15.12	54.64	4.24	Peak	210	153
3	5350.00	47.67	54.00	-6.33	43.24	4.43	Average	210	153
4	5350.00	59.90	74.00	-14.10	55.47	4.43	Peak	210	153
5	10540.00	56.40	68.20	-11.80	42.60	13.80	Peak	100	158
6	15810.00	44.08	54.00	-9.92	29.54	14.54	Average	100	158
7	15810.00	58.22	74.00	-15.78	43.68	14.54	Peak	100	158

Note 1: Emission Level (dBuV/m) = SA Reading (dBuV/m) + Factor* (dB)

*Factor includes antenna factor , cable loss and amplifier gain

Note 2: Margin (dB) = Emission level (dBuV/m) – Limit (dBuV/m).

Modulation	VHT40	Test Freq. (MHz)	5310
Polarization	Horizontal		

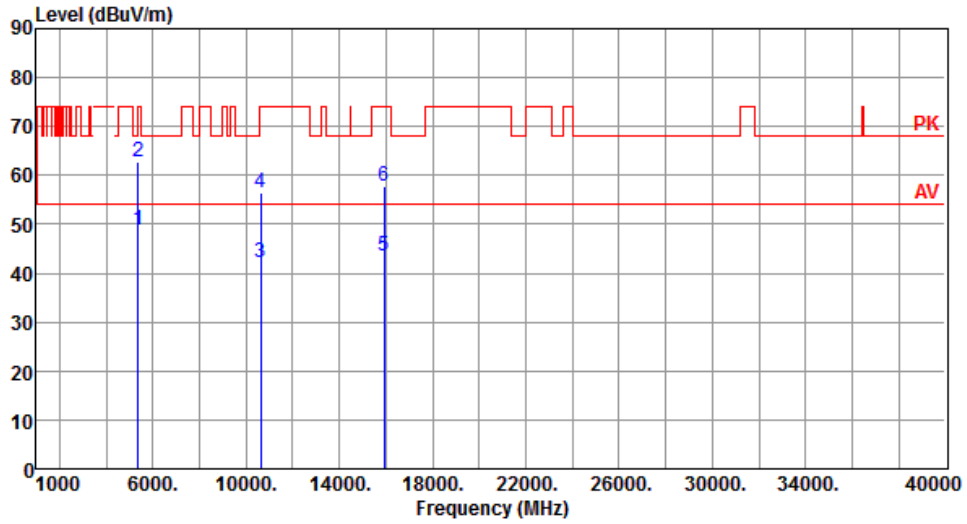

	Freq. MHz	Emission level dBuV/m	Limit dBuV/m	Margin dB	SA reading dBuV	Factor dB	Remark	ANT High cm	Turn Table deg
1	5350.00	48.78	54.00	-5.22	44.35	4.43	Average	188	82
2	5350.00	62.62	74.00	-11.38	58.19	4.43	Peak	188	82
3	10620.00	42.33	54.00	-11.67	28.44	13.89	Average	100	85
4	10620.00	56.53	74.00	-17.47	42.64	13.89	Peak	100	85
5	15930.00	43.67	54.00	-10.33	29.20	14.47	Average	100	91
6	15930.00	57.78	74.00	-16.22	43.31	14.47	Peak	100	91

Note 1: Emission Level (dBuV/m) = SA Reading (dBuV/m) + Factor* (dB)

*Factor includes antenna factor , cable loss and amplifier gain

Note 2: Margin (dB) = Emission level (dBuV/m) – Limit (dBuV/m).

Modulation	VHT40	Test Freq. (MHz)	5310
Polarization	Vertical		

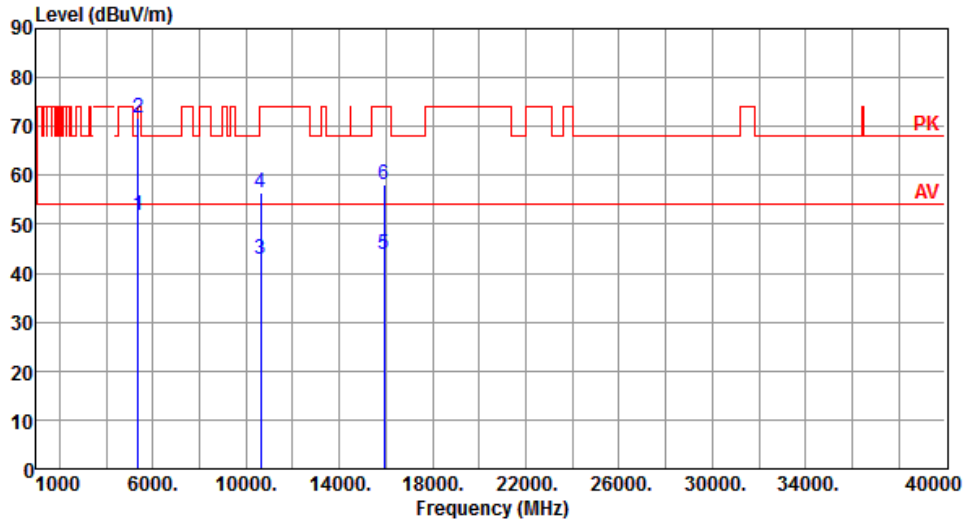

	Freq. MHz	Emission level dBuV/m	Limit dBuV/m	Margin dB	SA reading dBuV	Factor dB	Remark	ANT High cm	Turn Table deg
1	5350.00	51.90	54.00	-2.10	47.47	4.43	Average	194	145
2	5350.00	71.74	74.00	-2.26	67.31	4.43	Peak	194	145
3	10620.00	42.79	54.00	-11.21	28.90	13.89	Average	100	141
4	10620.00	56.46	74.00	-17.54	42.57	13.89	Peak	100	141
5	15930.00	44.00	54.00	-10.00	29.53	14.47	Average	100	141
6	15930.00	58.16	74.00	-15.84	43.69	14.47	Peak	100	141

Note 1: Emission Level (dBuV/m) = SA Reading (dBuV/m) + Factor* (dB)

*Factor includes antenna factor , cable loss and amplifier gain

Note 2: Margin (dB) = Emission level (dBuV/m) – Limit (dBuV/m).

Modulation	VHT40	Test Freq. (MHz)	5510
Polarization	Horizontal		

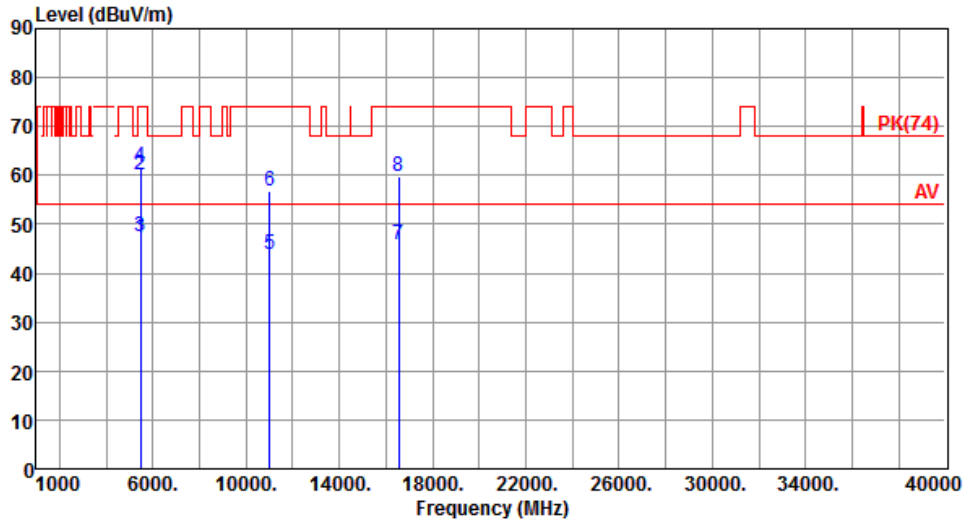

	Freq. MHz	Emission level dBuV/m	Limit dBuV/m	Margin dB	SA reading dBuV	Factor dB	Remark	ANT High cm	Turn Table deg
1	5460.00	47.18	54.00	-6.82	42.67	4.51	Average	186	88
2	5460.00	60.15	74.00	-13.85	55.64	4.51	Peak	186	88
3	5470.00	47.63	54.00	-6.37	43.11	4.52	Average	186	88
4	5470.00	61.83	74.00	-12.17	57.31	4.52	Peak	186	88
5	11020.00	43.86	54.00	-10.14	29.54	14.32	Average	100	92
6	11020.00	56.79	74.00	-17.21	42.47	14.32	Peak	100	92
7	16530.00	45.84	54.00	-8.16	29.31	16.53	Average	100	98
8	16530.00	59.67	74.00	-14.33	43.14	16.53	Peak	100	98

Note 1: Emission Level (dBuV/m) = SA Reading (dBuV/m) + Factor* (dB)

*Factor includes antenna factor , cable loss and amplifier gain

Note 2: Margin (dB) = Emission level (dBuV/m) – Limit (dBuV/m).

Modulation	VHT40	Test Freq. (MHz)	5510
Polarization	Vertical		

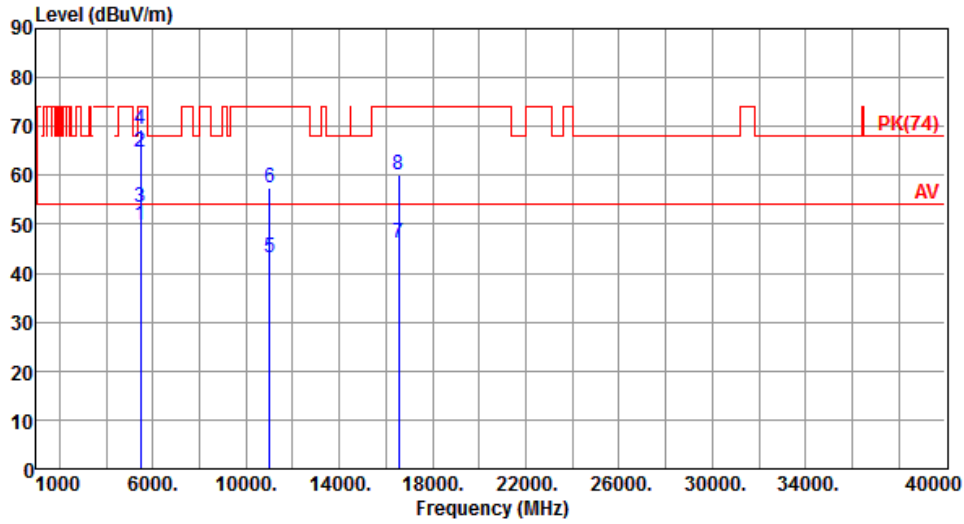

	Freq. MHz	Emission level dBuV/m	Limit dBuV/m	Margin dB	SA reading dBuV	Factor dB	Remark	ANT High cm	Turn Table deg
1	5460.00	49.82	54.00	-4.18	45.31	4.51	Average	166	148
2	5460.00	64.64	74.00	-9.36	60.13	4.51	Peak	166	148
3	5470.00	53.43	54.00	-0.57	48.91	4.52	Average	166	148
4	5470.00	69.36	74.00	-4.64	64.84	4.52	Peak	166	148
5	11020.00	43.03	54.00	-10.97	28.71	14.32	Average	100	154
6	11020.00	57.56	74.00	-16.44	43.24	14.32	Peak	100	154
7	16530.00	46.28	54.00	-7.72	29.75	16.53	Average	100	159
8	16530.00	60.10	74.00	-13.90	43.57	16.53	Peak	100	159

Note 1: Emission Level (dBuV/m) = SA Reading (dBuV/m) + Factor* (dB)

*Factor includes antenna factor , cable loss and amplifier gain

Note 2: Margin (dB) = Emission level (dBuV/m) – Limit (dBuV/m).

Modulation	VHT40	Test Freq. (MHz)	5590
Polarization	Horizontal		

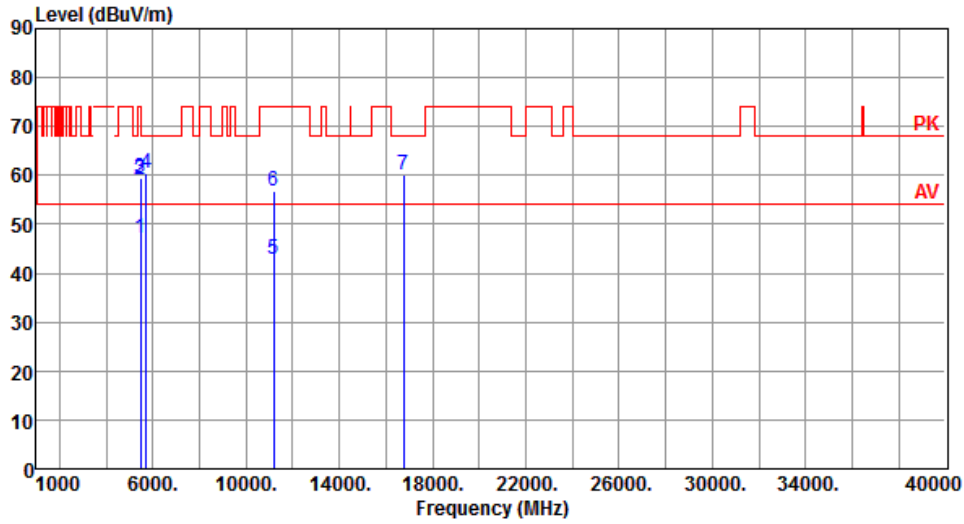

	Freq. MHz	Emission level dBuV/m	Limit dBuV/m	Margin dB	SA reading dBuV	Factor dB	Remark	ANT High cm	Turn Table deg
1	5460.00	47.11	54.00	-6.89	42.60	4.51	Average	180	89
2	5460.00	58.98	74.00	-15.02	54.47	4.51	Peak	180	89
3	5470.00	59.41	68.20	-8.79	54.89	4.52	Peak	180	89
4	5725.00	60.53	68.20	-7.67	55.71	4.82	Peak	180	89
5	11180.00	42.86	54.00	-11.14	28.67	14.19	Average	100	87
6	11180.00	56.88	74.00	-17.12	42.69	14.19	Peak	100	87
7	16770.00	59.98	68.20	-8.22	43.01	16.97	Peak	100	95

Note 1: Emission Level (dBuV/m) = SA Reading (dBuV/m) + Factor* (dB)

*Factor includes antenna factor , cable loss and amplifier gain

Note 2: Margin (dB) = Emission level (dBuV/m) – Limit (dBuV/m).

Modulation	VHT40	Test Freq. (MHz)	5590
Polarization	Vertical		

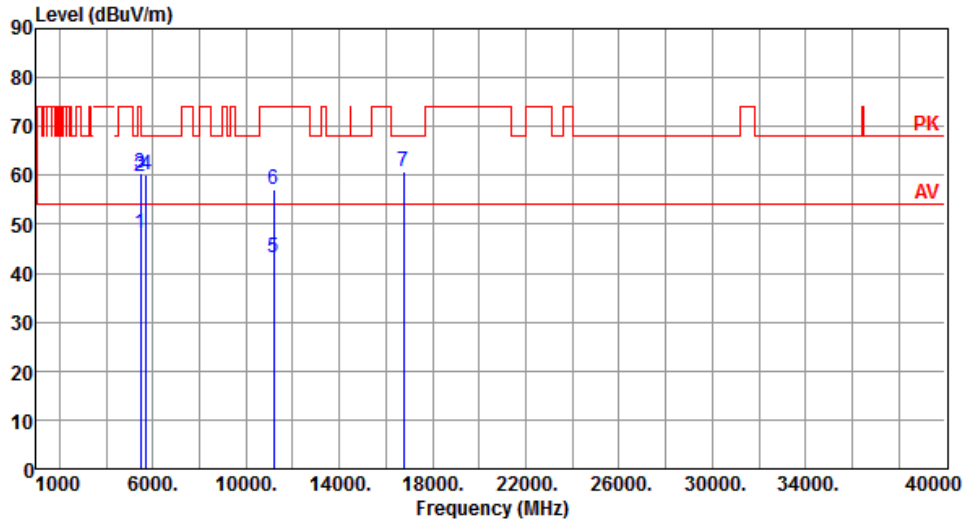

	Freq. MHz	Emission level dBuV/m	Limit dBuV/m	Margin dB	SA reading dBuV	Factor dB	Remark	ANT High cm	Turn Table deg
1	5460.00	48.05	54.00	-5.95	43.54	4.51	Average	175	154
2	5460.00	59.92	74.00	-14.08	55.41	4.51	Peak	175	154
3	5470.00	60.57	68.20	-7.63	56.05	4.52	Peak	175	154
4	5725.00	59.97	68.20	-8.23	55.15	4.82	Peak	175	154
5	11180.00	43.10	54.00	-10.90	28.91	14.19	Average	100	159
6	11180.00	57.18	74.00	-16.82	42.99	14.19	Peak	100	159
7	16770.00	60.76	68.20	-7.44	43.79	16.97	Peak	100	149

Note 1: Emission Level (dBuV/m) = SA Reading (dBuV/m) + Factor* (dB)

*Factor includes antenna factor , cable loss and amplifier gain

Note 2: Margin (dB) = Emission level (dBuV/m) – Limit (dBuV/m).

Modulation	VHT40	Test Freq. (MHz)	5670
Polarization	Horizontal		

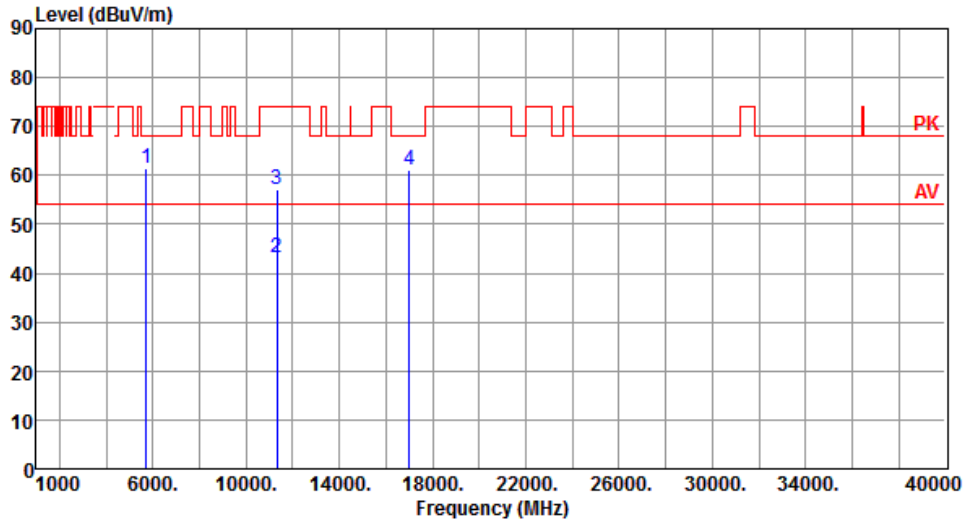

	Freq. MHz	Emission level dBuV/m	Limit dBuV/m	Margin dB	SA reading dBuV	Factor dB	Remark	ANT High cm	Turn Table deg
1	5725.00	61.40	68.20	-6.80	56.58	4.82	Peak	214	95
2	11340.00	43.02	54.00	-10.98	28.97	14.05	Average	100	91
3	11340.00	56.99	74.00	-17.01	42.94	14.05	Peak	100	91
4	17010.00	60.99	68.20	-7.21	43.58	17.41	Peak	100	89

Note 1: Emission Level (dBuV/m) = SA Reading (dBuV/m) + Factor* (dB)

*Factor includes antenna factor , cable loss and amplifier gain

Note 2: Margin (dB) = Emission level (dBuV/m) – Limit (dBuV/m).

Modulation	VHT40	Test Freq. (MHz)	5670
Polarization	Vertical		

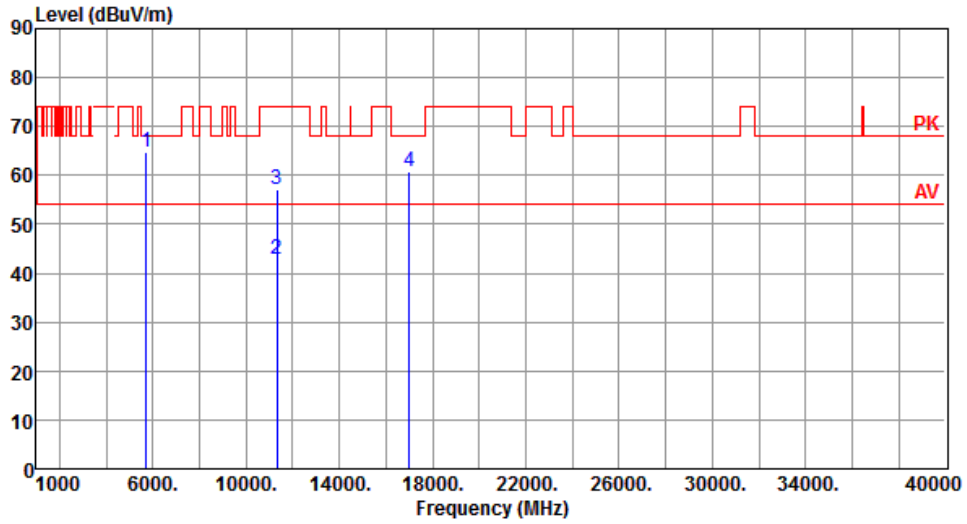

	Freq. MHz	Emission level dBuV/m	Limit dBuV/m	Margin dB	SA reading dBuV	Factor dB	Remark	ANT High cm	Turn Table deg
1	5725.00	64.78	68.20	-3.42	59.96	4.82	Peak	176	153
2	11340.00	42.99	54.00	-11.01	28.94	14.05	Average	100	157
3	11340.00	57.09	74.00	-16.91	43.04	14.05	Peak	100	157
4	17010.00	60.77	68.20	-7.43	43.36	17.41	Peak	100	149

Note 1: Emission Level (dBuV/m) = SA Reading (dBuV/m) + Factor* (dB)

*Factor includes antenna factor , cable loss and amplifier gain

Note 2: Margin (dB) = Emission level (dBuV/m) – Limit (dBuV/m).

Modulation	VHT40	Test Freq. (MHz)	5710
Polarization	Horizontal		

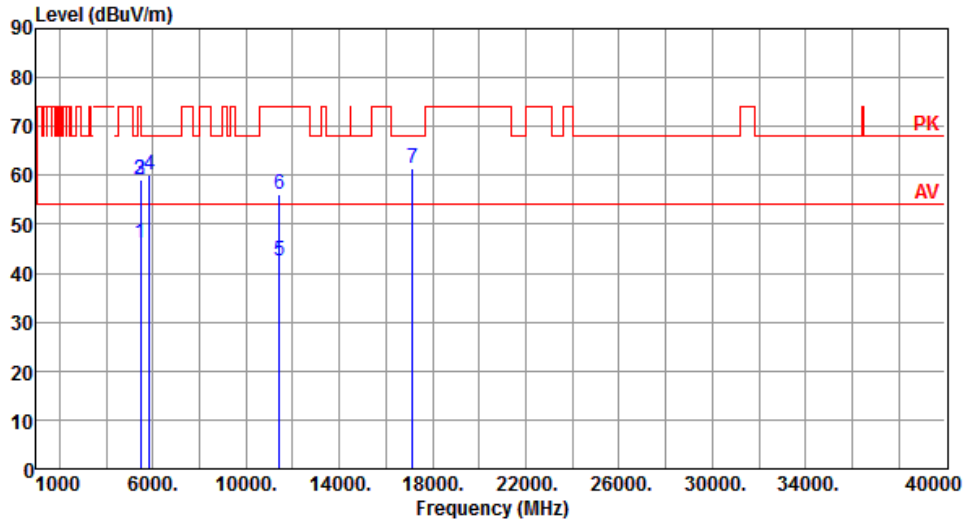

	Freq. MHz	Emission level dBuV/m	Limit dBuV/m	Margin dB	SA reading dBuV	Factor dB	Remark	ANT High cm	Turn Table deg
1	5460.00	46.11	54.00	-7.89	41.60	4.51	Average	216	97
2	5460.00	59.16	74.00	-14.84	54.65	4.51	Peak	216	97
3	5470.00	58.96	68.20	-9.24	54.44	4.52	Peak	216	97
4	5850.00	60.17	68.20	-8.03	55.18	4.99	Peak	216	97
5	11420.00	42.37	54.00	-11.63	28.40	13.97	Average	100	95
6	11420.00	56.24	74.00	-17.76	42.27	13.97	Peak	100	95
7	17130.00	61.42	68.20	-6.78	43.67	17.75	Peak	100	97

Note 1: Emission Level (dBuV/m) = SA Reading (dBuV/m) + Factor* (dB)

*Factor includes antenna factor , cable loss and amplifier gain

Note 2: Margin (dB) = Emission level (dBuV/m) – Limit (dBuV/m).

Modulation	VHT40	Test Freq. (MHz)	5710
Polarization	Vertical		

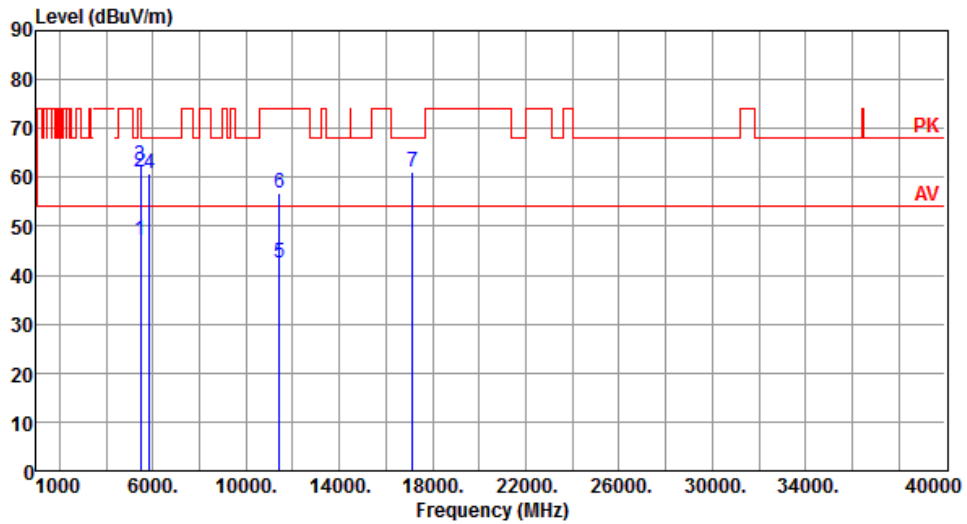

	Freq. MHz	Emission level dBuV/m	Limit dBuV/m	Margin dB	SA reading dBuV	Factor dB	Remark	ANT High cm	Turn Table deg
1	5460.00	47.10	54.00	-6.90	42.59	4.51	Average	160	147
2	5460.00	61.01	74.00	-12.99	56.50	4.51	Peak	160	147
3	5470.00	62.46	68.20	-5.74	57.94	4.52	Peak	160	147
4	5850.00	60.84	68.20	-7.36	55.85	4.99	Peak	160	147
5	11420.00	42.67	54.00	-11.33	28.70	13.97	Average	100	153
6	11420.00	56.83	74.00	-17.17	42.86	13.97	Peak	100	153
7	17130.00	61.05	68.20	-7.15	43.30	17.75	Peak	100	151

Note 1: Emission Level (dBuV/m) = SA Reading (dBuV/m) + Factor* (dB)

*Factor includes antenna factor , cable loss and amplifier gain

Note 2: Margin (dB) = Emission level (dBuV/m) – Limit (dBuV/m).

Modulation	VHT40	Test Freq. (MHz)	5755
Polarization	Horizontal		

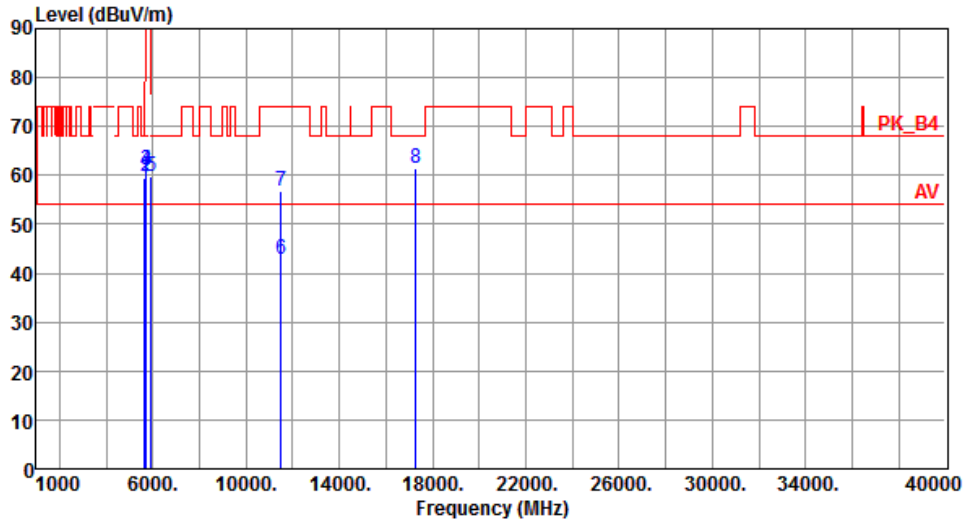

	Freq. MHz	Emission level dBuV/m	Limit dBuV/m	Margin dB	SA reading dBuV	Factor dB	Remark	ANT High cm	Turn Table deg
1	5650.00	59.37	68.20	-8.83	54.64	4.73	Peak	198	97
2	5700.00	59.76	105.20	-45.44	54.97	4.79	Peak	198	97
3	5720.00	61.03	110.80	-49.77	56.21	4.82	Peak	198	97
4	5725.00	61.15	122.20	-61.05	56.33	4.82	Peak	198	97
5	5925.00	59.77	68.20	-8.43	54.69	5.08	Peak	198	97
6	11510.00	42.80	54.00	-11.20	28.90	13.90	Average	100	102
7	11510.00	56.79	74.00	-17.21	42.89	13.90	Peak	100	102
8	17265.00	61.43	68.20	-6.77	43.31	18.12	Peak	100	107

Note 1: Emission Level (dBuV/m) = SA Reading (dBuV/m) + Factor* (dB)

*Factor includes antenna factor , cable loss and amplifier gain

Note 2: Margin (dB) = Emission level (dBuV/m) – Limit (dBuV/m).

Modulation	VHT40	Test Freq. (MHz)	5755
Polarization	Vertical		

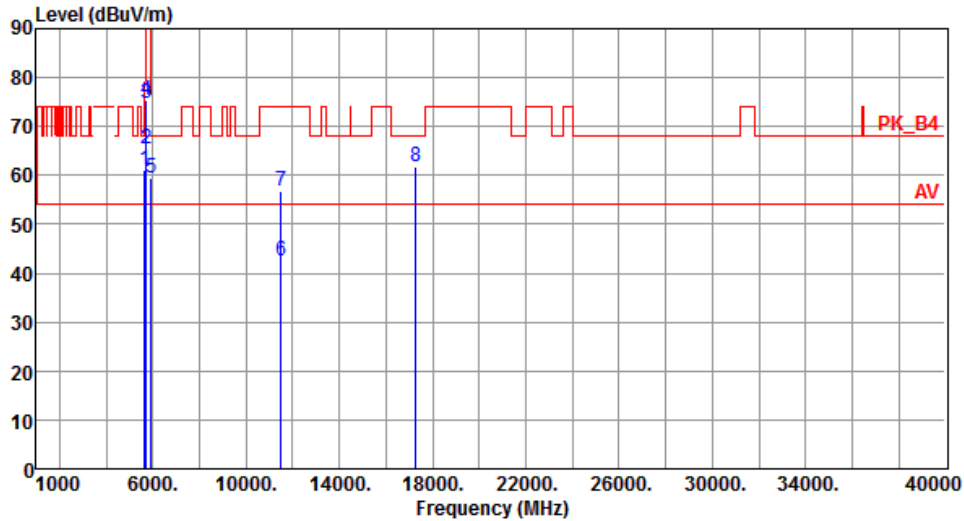

	Freq. MHz	Emission level dBuV/m	Limit dBuV/m	Margin dB	SA reading dBuV	Factor dB	Remark	ANT High cm	Turn Table deg
1	5650.00	60.99	68.20	-7.21	56.26	4.73	Peak	180	152
2	5700.00	65.31	105.20	-39.89	60.52	4.79	Peak	180	152
3	5720.00	74.64	110.80	-36.16	69.82	4.82	Peak	180	152
4	5725.00	75.51	122.20	-46.69	70.69	4.82	Peak	180	152
5	5925.00	59.51	68.20	-8.69	54.43	5.08	Peak	180	152
6	11510.00	42.50	54.00	-11.50	28.60	13.90	Average	100	144
7	11510.00	56.84	74.00	-17.16	42.94	13.90	Peak	100	144
8	17265.00	61.66	68.20	-6.54	43.54	18.12	Peak	100	148

Note 1: Emission Level (dBuV/m) = SA Reading (dBuV/m) + Factor* (dB)

*Factor includes antenna factor , cable loss and amplifier gain

Note 2: Margin (dB) = Emission level (dBuV/m) – Limit (dBuV/m).

Modulation	VHT40	Test Freq. (MHz)	5795
Polarization	Horizontal		

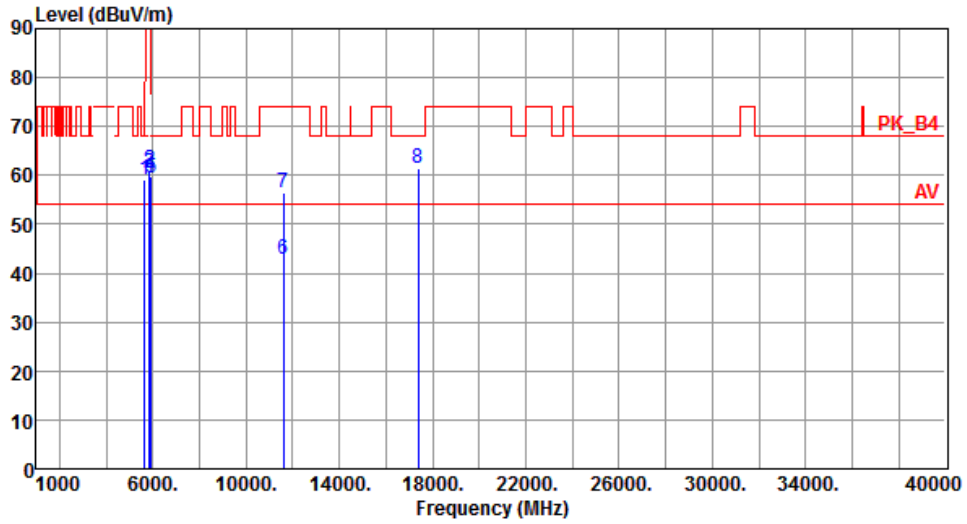

	Freq. MHz	Emission level dBuV/m	Limit dBuV/m	Margin dB	SA reading dBuV	Factor dB	Remark	ANT High cm	Turn Table deg
1	5650.00	59.26	68.20	-8.94	54.53	4.73	Peak	210	99
2	5850.00	60.96	122.20	-61.24	55.97	4.99	Peak	210	99
3	5855.00	60.34	110.80	-50.46	55.34	5.00	Peak	210	99
4	5875.00	59.69	105.20	-45.51	54.67	5.02	Peak	210	99
5	5925.00	59.39	68.20	-8.81	54.31	5.08	Peak	210	99
6	11590.00	42.70	54.00	-11.30	28.89	13.81	Average	100	101
7	11590.00	56.48	74.00	-17.52	42.67	13.81	Peak	100	101
8	17385.00	61.45	68.20	-6.75	43.00	18.45	Peak	100	95

Note 1: Emission Level (dBuV/m) = SA Reading (dBuV/m) + Factor* (dB)

*Factor includes antenna factor , cable loss and amplifier gain

Note 2: Margin (dB) = Emission level (dBuV/m) – Limit (dBuV/m).

Modulation	VHT40	Test Freq. (MHz)	5795
Polarization	Vertical		

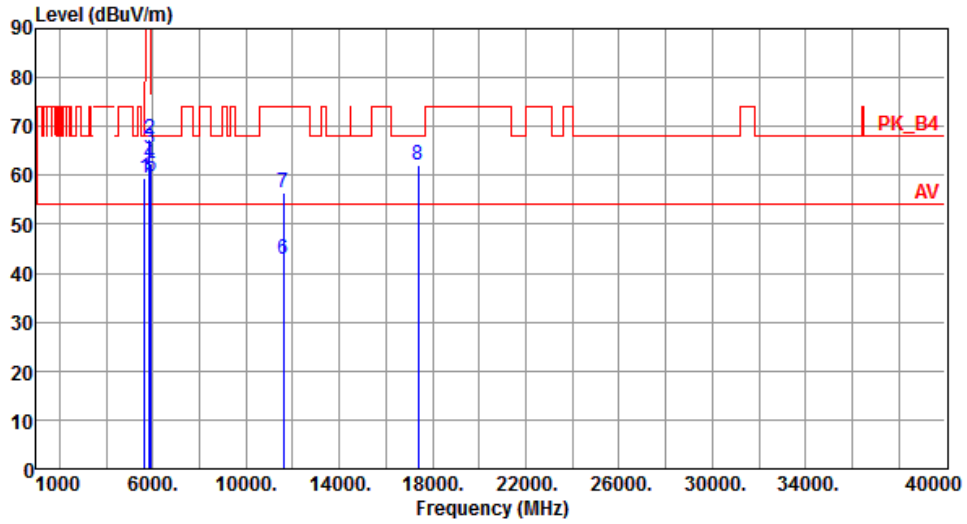

	Freq. MHz	Emission level dBuV/m	Limit dBuV/m	Margin dB	SA reading dBuV	Factor dB	Remark	ANT High cm	Turn Table deg
1	5650.00	59.61	68.20	-8.59	54.88	4.73	Peak	187	155
2	5850.00	67.26	122.20	-54.94	62.27	4.99	Peak	187	155
3	5855.00	65.41	110.80	-45.39	60.41	5.00	Peak	187	155
4	5875.00	62.34	105.20	-42.86	57.32	5.02	Peak	187	155
5	5925.00	59.92	68.20	-8.28	54.84	5.08	Peak	187	155
6	11590.00	42.71	54.00	-11.29	28.90	13.81	Average	100	147
7	11590.00	56.51	74.00	-17.49	42.70	13.81	Peak	100	147
8	17385.00	61.97	68.20	-6.23	43.52	18.45	Peak	100	147

Note 1: Emission Level (dBuV/m) = SA Reading (dBuV/m) + Factor* (dB)

*Factor includes antenna factor , cable loss and amplifier gain

Note 2: Margin (dB) = Emission level (dBuV/m) – Limit (dBuV/m).

3.5.8 Transmitter Radiated Unwanted Emissions (Above 1GHz) for VHT80

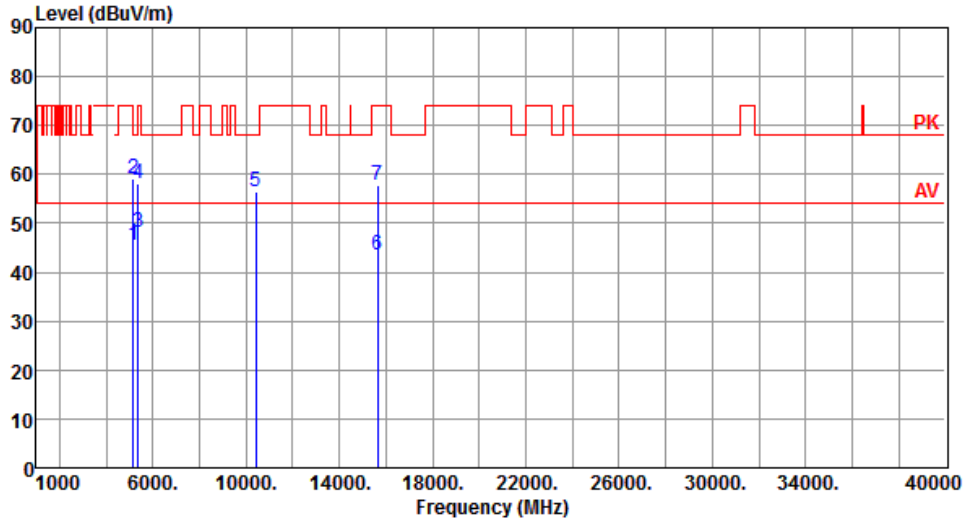
Modulation	VHT80	Test Freq. (MHz)	5210																																																																																														
Polarization	Horizontal																																																																																																
																																																																																																	
	<table border="1"> <thead> <tr> <th>Freq.</th> <th>Emission level</th> <th>Limit</th> <th>Margin</th> <th>SA reading</th> <th>Factor</th> <th>Remark</th> <th>ANT High</th> <th>Turn Table</th> </tr> <tr> <th>MHz</th> <th>dBuV/m</th> <th>dBuV/m</th> <th>dB</th> <th>dBuV</th> <th>dB</th> <th></th> <th>cm</th> <th>deg</th> </tr> </thead> <tbody> <tr> <td>1</td> <td>5150.00</td> <td>45.51</td> <td>54.00</td> <td>-8.49</td> <td>41.27</td> <td>4.24</td> <td>Average</td> <td>182</td> <td>129</td> </tr> <tr> <td>2</td> <td>5150.00</td> <td>59.15</td> <td>74.00</td> <td>-14.85</td> <td>54.91</td> <td>4.24</td> <td>Peak</td> <td>182</td> <td>129</td> </tr> <tr> <td>3</td> <td>5350.00</td> <td>47.99</td> <td>54.00</td> <td>-6.01</td> <td>43.56</td> <td>4.43</td> <td>Average</td> <td>182</td> <td>129</td> </tr> <tr> <td>4</td> <td>5350.00</td> <td>58.01</td> <td>74.00</td> <td>-15.99</td> <td>53.58</td> <td>4.43</td> <td>Peak</td> <td>182</td> <td>129</td> </tr> <tr> <td>5</td> <td>10420.00</td> <td>56.41</td> <td>68.20</td> <td>-11.79</td> <td>42.69</td> <td>13.72</td> <td>Peak</td> <td>100</td> <td>115</td> </tr> <tr> <td>6</td> <td>15630.00</td> <td>43.60</td> <td>54.00</td> <td>-10.40</td> <td>28.97</td> <td>14.63</td> <td>Average</td> <td>100</td> <td>105</td> </tr> <tr> <td>7</td> <td>15630.00</td> <td>57.88</td> <td>74.00</td> <td>-16.12</td> <td>43.25</td> <td>14.63</td> <td>Peak</td> <td>100</td> <td>105</td> </tr> </tbody> </table>	Freq.	Emission level	Limit	Margin	SA reading	Factor	Remark	ANT High	Turn Table	MHz	dBuV/m	dBuV/m	dB	dBuV	dB		cm	deg	1	5150.00	45.51	54.00	-8.49	41.27	4.24	Average	182	129	2	5150.00	59.15	74.00	-14.85	54.91	4.24	Peak	182	129	3	5350.00	47.99	54.00	-6.01	43.56	4.43	Average	182	129	4	5350.00	58.01	74.00	-15.99	53.58	4.43	Peak	182	129	5	10420.00	56.41	68.20	-11.79	42.69	13.72	Peak	100	115	6	15630.00	43.60	54.00	-10.40	28.97	14.63	Average	100	105	7	15630.00	57.88	74.00	-16.12	43.25	14.63	Peak	100	105								
Freq.	Emission level	Limit	Margin	SA reading	Factor	Remark	ANT High	Turn Table																																																																																									
MHz	dBuV/m	dBuV/m	dB	dBuV	dB		cm	deg																																																																																									
1	5150.00	45.51	54.00	-8.49	41.27	4.24	Average	182	129																																																																																								
2	5150.00	59.15	74.00	-14.85	54.91	4.24	Peak	182	129																																																																																								
3	5350.00	47.99	54.00	-6.01	43.56	4.43	Average	182	129																																																																																								
4	5350.00	58.01	74.00	-15.99	53.58	4.43	Peak	182	129																																																																																								
5	10420.00	56.41	68.20	-11.79	42.69	13.72	Peak	100	115																																																																																								
6	15630.00	43.60	54.00	-10.40	28.97	14.63	Average	100	105																																																																																								
7	15630.00	57.88	74.00	-16.12	43.25	14.63	Peak	100	105																																																																																								
<p>Note 1: Emission Level (dBuV/m) = SA Reading (dBuV/m) + Factor* (dB) *Factor includes antenna factor , cable loss and amplifier gain Note 2: Margin (dB) = Emission level (dBuV/m) – Limit (dBuV/m).</p>																																																																																																	

Modulation	VHT80	Test Freq. (MHz)	5210
Polarization	Vertical		

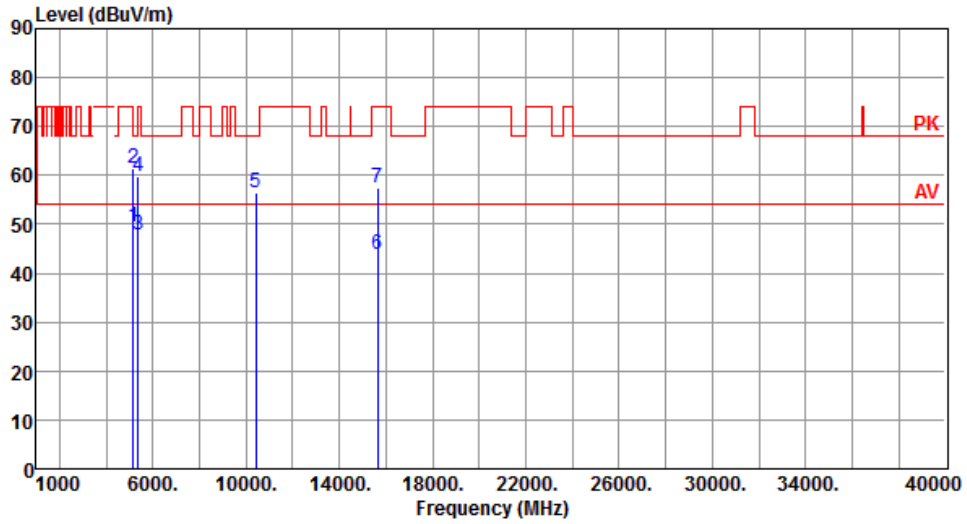

	Freq. MHz	Emission level dBuV/m	Limit dBuV/m	Margin dB	SA reading dBuV	Factor dB	Remark	ANT High cm	Turn Table deg
1	5150.00	49.49	54.00	-4.51	45.25	4.24	Average	175	142
2	5150.00	61.45	74.00	-12.55	57.21	4.24	Peak	175	142
3	5350.00	47.97	54.00	-6.03	43.54	4.43	Average	175	142
4	5350.00	59.83	74.00	-14.17	55.40	4.43	Peak	175	142
5	10420.00	56.61	68.20	-11.59	42.89	13.72	Peak	100	151
6	15630.00	43.73	54.00	-10.27	29.10	14.63	Average	100	146
7	15630.00	57.37	74.00	-16.63	42.74	14.63	Peak	100	146

Note 1: Emission Level (dBuV/m) = SA Reading (dBuV/m) + Factor* (dB)

*Factor includes antenna factor , cable loss and amplifier gain

Note 2: Margin (dB) = Emission level (dBuV/m) – Limit (dBuV/m).

Modulation	VHT80	Test Freq. (MHz)	5290
Polarization	Horizontal		

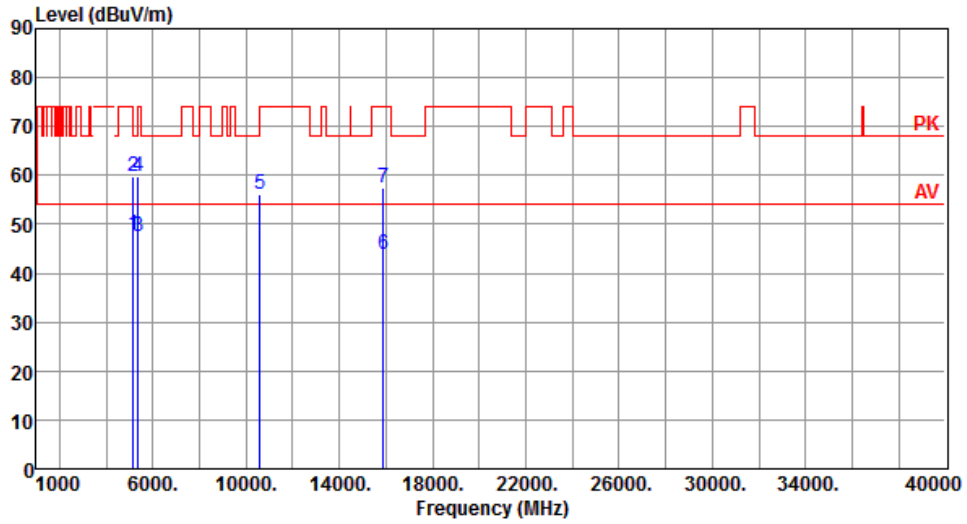

	Freq. MHz	Emission level dBuV/m	Limit dBuV/m	Margin dB	SA reading dBuV	Factor dB	Remark	ANT High cm	Turn Table deg
1	5150.00	47.82	54.00	-6.18	43.58	4.24	Average	182	126
2	5150.00	59.93	74.00	-14.07	55.69	4.24	Peak	182	126
3	5350.00	47.46	54.00	-6.54	43.03	4.43	Average	182	126
4	5350.00	59.72	74.00	-14.28	55.29	4.43	Peak	182	126
5	10580.00	56.24	68.20	-11.96	42.40	13.84	Peak	100	113
6	15870.00	43.84	54.00	-10.16	29.34	14.50	Average	100	118
7	15870.00	57.60	74.00	-16.40	43.10	14.50	Peak	100	118

Note 1: Emission Level (dBuV/m) = SA Reading (dBuV/m) + Factor* (dB)

*Factor includes antenna factor , cable loss and amplifier gain

Note 2: Margin (dB) = Emission level (dBuV/m) – Limit (dBuV/m).

Modulation	VHT80	Test Freq. (MHz)	5290
Polarization	Vertical		

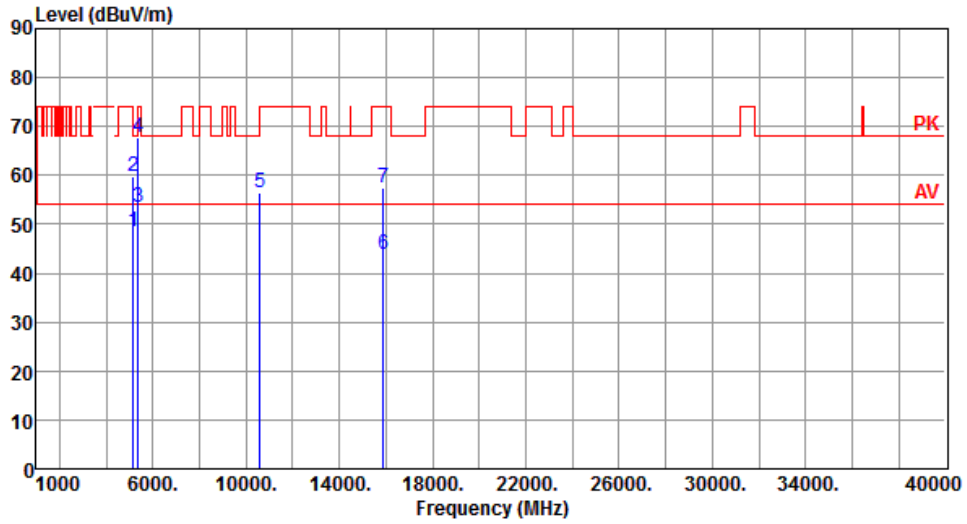

	Freq. MHz	Emission level dBuV/m	Limit dBuV/m	Margin dB	SA reading dBuV	Factor dB	Remark	ANT High cm	Turn Table deg
1	5150.00	48.55	54.00	-5.45	44.31	4.24	Average	213	151
2	5150.00	59.71	74.00	-14.29	55.47	4.24	Peak	213	151
3	5350.00	53.42	54.00	-0.58	48.99	4.43	Average	213	151
4	5350.00	67.61	74.00	-6.39	63.18	4.43	Peak	213	151
5	10580.00	56.58	68.20	-11.62	42.74	13.84	Peak	100	158
6	15870.00	43.81	54.00	-10.19	29.31	14.50	Average	100	149
7	15870.00	57.52	74.00	-16.48	43.02	14.50	Peak	100	149

Note 1: Emission Level (dBuV/m) = SA Reading (dBuV/m) + Factor* (dB)

*Factor includes antenna factor , cable loss and amplifier gain

Note 2: Margin (dB) = Emission level (dBuV/m) – Limit (dBuV/m).

Modulation	VHT80	Test Freq. (MHz)	5530
Polarization	Horizontal		

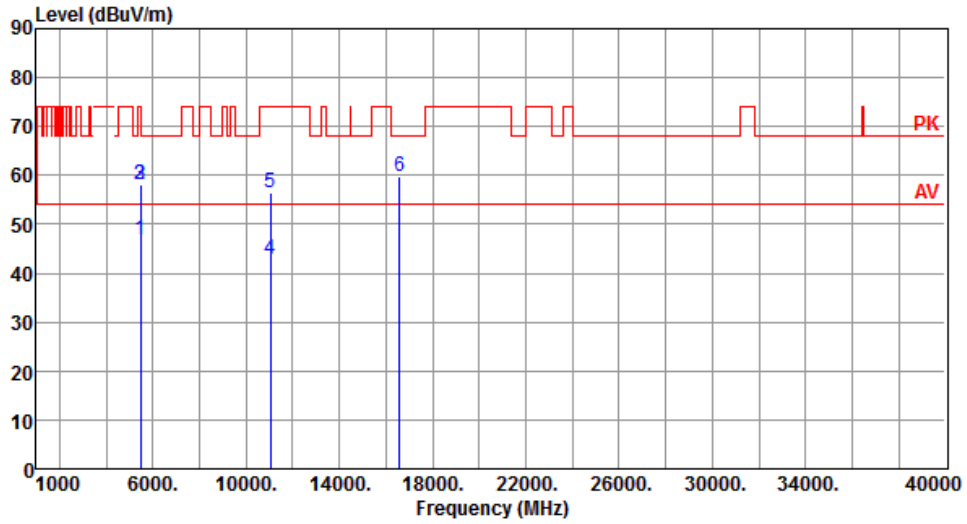

	Freq. MHz	Emission level dBuV/m	Limit dBuV/m	Margin dB	SA reading dBuV	Factor dB	Remark	ANT High cm	Turn Table deg
1	5460.00	46.85	54.00	-7.15	42.34	4.51	Average	184	90
2	5460.00	58.05	74.00	-15.95	53.54	4.51	Peak	184	90
3	5470.00	58.21	68.20	-9.99	53.69	4.52	Peak	184	90
4	11060.00	42.93	54.00	-11.07	28.64	14.29	Average	100	95
5	11060.00	56.59	74.00	-17.41	42.30	14.29	Peak	100	95
6	16590.00	59.88	68.20	-8.32	43.24	16.64	Peak	100	100

Note 1: Emission Level (dBuV/m) = SA Reading (dBuV/m) + Factor* (dB)

*Factor includes antenna factor , cable loss and amplifier gain

Note 2: Margin (dB) = Emission level (dBuV/m) – Limit (dBuV/m).

Modulation	VHT80	Test Freq. (MHz)	5530
Polarization	Vertical		

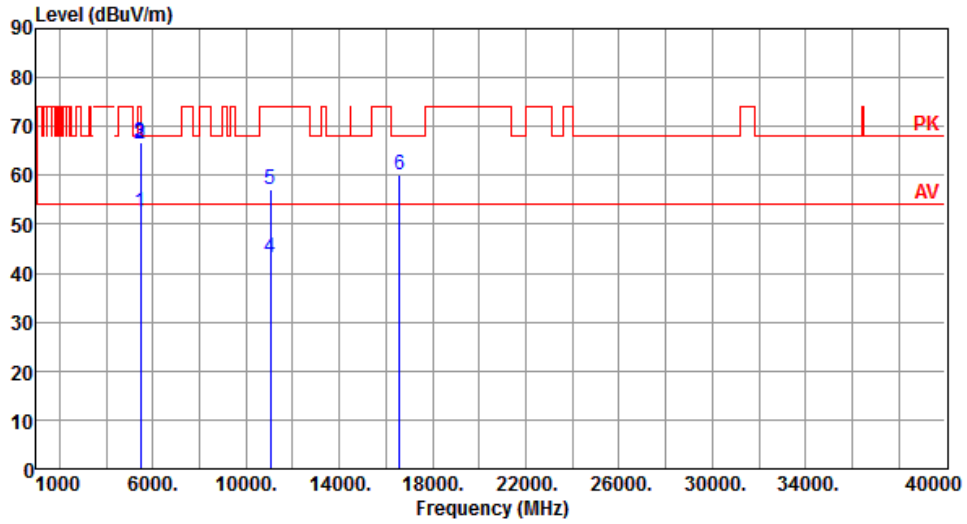

	Freq. MHz	Emission level dBuV/m	Limit dBuV/m	Margin dB	SA reading dBuV	Factor dB	Remark	ANT High cm	Turn Table deg
1	5460.00	52.37	54.00	-1.63	47.86	4.51	Average	185	145
2	5460.00	66.51	74.00	-7.49	62.00	4.51	Peak	185	145
3	5470.00	66.91	68.20	-1.29	62.39	4.52	Peak	185	145
4	11060.00	43.20	54.00	-10.80	28.91	14.29	Average	100	148
5	11060.00	57.13	74.00	-16.87	42.84	14.29	Peak	100	148
6	16590.00	59.95	68.20	-8.25	43.31	16.64	Peak	100	151

Note 1: Emission Level (dBuV/m) = SA Reading (dBuV/m) + Factor* (dB)

*Factor includes antenna factor , cable loss and amplifier gain

Note 2: Margin (dB) = Emission level (dBuV/m) – Limit (dBuV/m).

Modulation	VHT80	Test Freq. (MHz)	5610
Polarization	Horizontal		

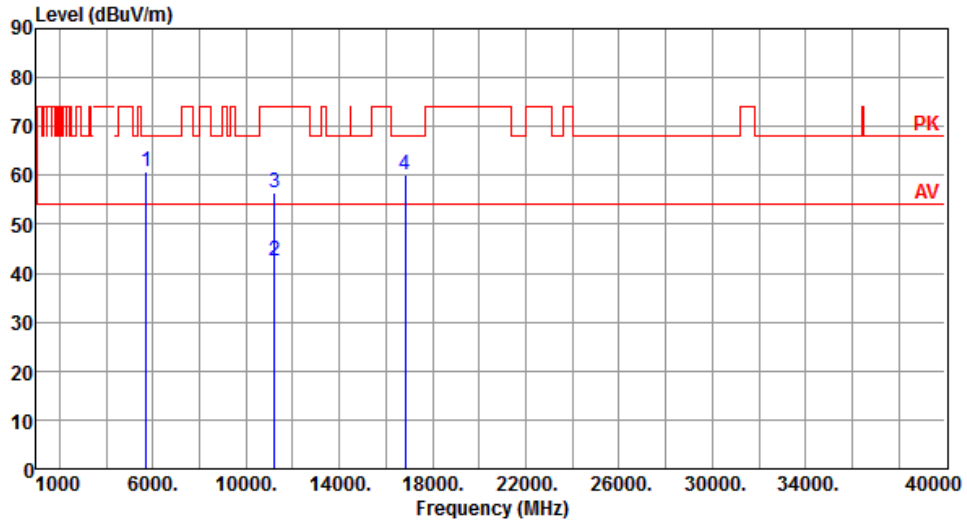

	Freq. MHz	Emission level dBuV/m	Limit dBuV/m	Margin dB	SA reading dBuV	Factor dB	Remark	ANT High cm	Turn Table deg
1	5725.00	60.67	68.20	-7.53	55.85	4.82	Peak	188	91
2	11220.00	42.49	54.00	-11.51	28.35	14.14	Average	100	92
3	11220.00	56.36	74.00	-17.64	42.22	14.14	Peak	100	92
4	16830.00	59.95	68.20	-8.25	42.87	17.08	Peak	100	95

Note 1: Emission Level (dBuV/m) = SA Reading (dBuV/m) + Factor* (dB)

*Factor includes antenna factor , cable loss and amplifier gain

Note 2: Margin (dB) = Emission level (dBuV/m) – Limit (dBuV/m).

Modulation	VHT80	Test Freq. (MHz)	5610
Polarization	Vertical		

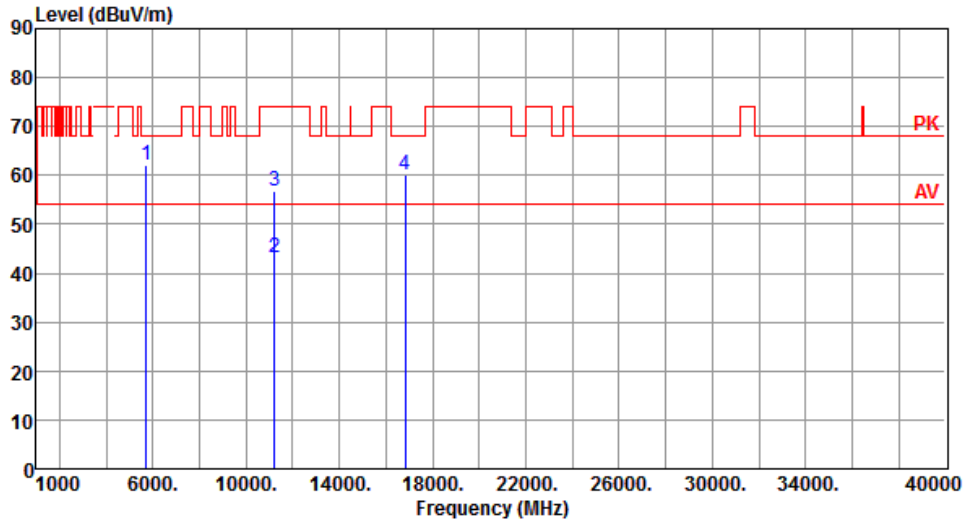

	Freq. MHz	Emission level dBuV/m	Limit dBuV/m	Margin dB	SA reading dBuV	Factor dB	Remark	ANT High cm	Turn Table deg
1	5725.00	62.17	68.20	-6.03	57.35	4.82	Peak	177	136
2	11220.00	43.05	54.00	-10.95	28.91	14.14	Average	100	142
3	11220.00	56.72	74.00	-17.28	42.58	14.14	Peak	100	142
4	16830.00	59.98	68.20	-8.22	42.90	17.08	Peak	100	147

Note 1: Emission Level (dBuV/m) = SA Reading (dBuV/m) + Factor* (dB)

*Factor includes antenna factor , cable loss and amplifier gain

Note 2: Margin (dB) = Emission level (dBuV/m) – Limit (dBuV/m).

Modulation	VHT80	Test Freq. (MHz)	5690
Polarization	Horizontal		

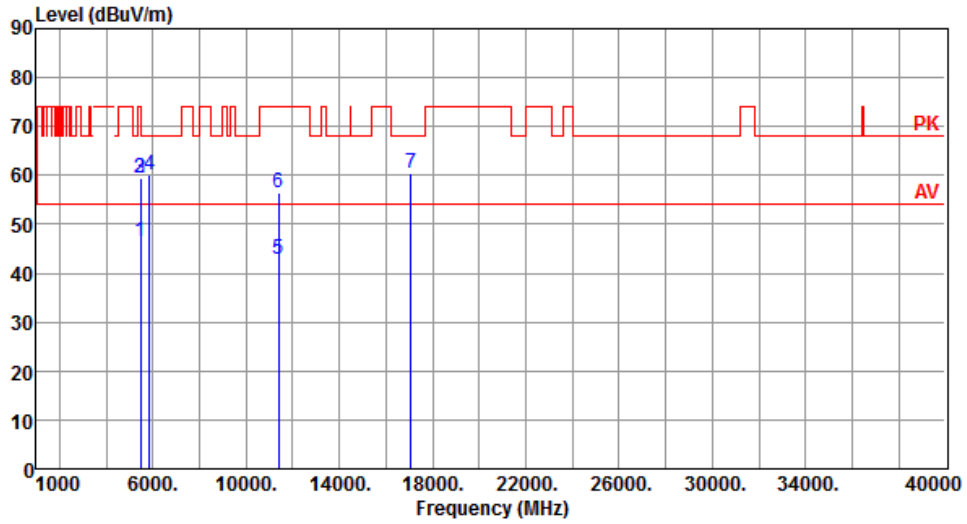

	Freq. MHz	Emission level dBuV/m	Limit dBuV/m	Margin dB	SA reading dBuV	Factor dB	Remark	ANT High cm	Turn Table deg
1	5460.00	46.34	54.00	-7.66	41.83	4.51	Average	200	130
2	5460.00	59.35	74.00	-14.65	54.84	4.51	Peak	200	130
3	5470.00	59.31	68.20	-8.89	54.79	4.52	Peak	200	130
4	5850.00	60.25	68.20	-7.95	55.26	4.99	Peak	200	130
5	11380.00	42.70	54.00	-11.30	28.68	14.02	Average	100	144
6	11380.00	56.37	74.00	-17.63	42.35	14.02	Peak	100	144
7	17070.00	60.59	68.20	-7.61	43.00	17.59	Peak	100	144

Note 1: Emission Level (dBuV/m) = SA Reading (dBuV/m) + Factor* (dB)

*Factor includes antenna factor , cable loss and amplifier gain

Note 2: Margin (dB) = Emission level (dBuV/m) – Limit (dBuV/m).

Modulation	VHT80	Test Freq. (MHz)	5690
Polarization	Vertical		

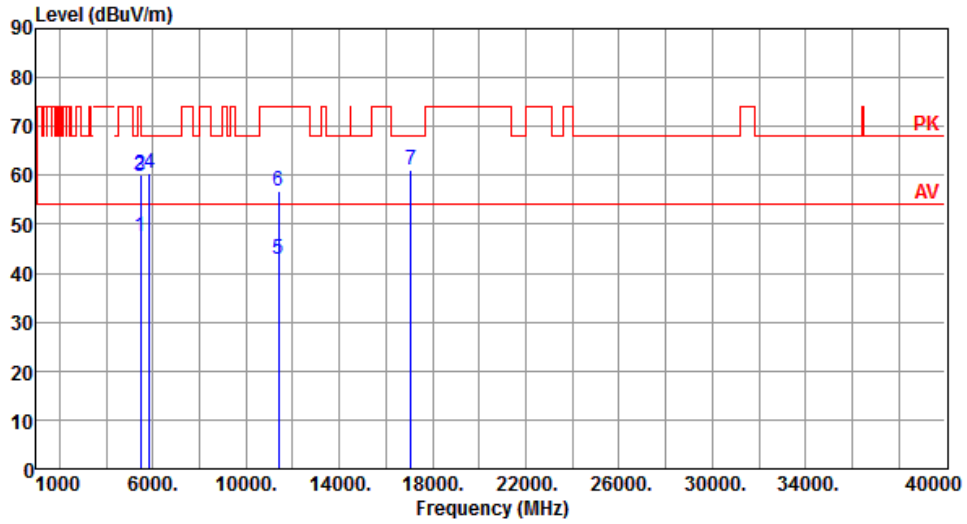

	Freq. MHz	Emission level dBuV/m	Limit dBuV/m	Margin dB	SA reading dBuV	Factor dB	Remark	ANT High cm	Turn Table deg
1	5460.00	47.44	54.00	-6.56	42.93	4.51	Average	176	142
2	5460.00	60.16	74.00	-13.84	55.65	4.51	Peak	176	142
3	5470.00	59.70	68.20	-8.50	55.18	4.52	Peak	176	142
4	5850.00	60.51	68.20	-7.69	55.52	4.99	Peak	176	142
5	11380.00	42.70	54.00	-11.30	28.68	14.02	Average	100	145
6	11380.00	56.70	74.00	-17.30	42.68	14.02	Peak	100	145
7	17070.00	60.94	68.20	-7.26	43.35	17.59	Peak	100	141

Note 1: Emission Level (dBuV/m) = SA Reading (dBuV/m) + Factor* (dB)

*Factor includes antenna factor , cable loss and amplifier gain

Note 2: Margin (dB) = Emission level (dBuV/m) – Limit (dBuV/m).

Modulation	VHT80	Test Freq. (MHz)	5775
Polarization	Horizontal		

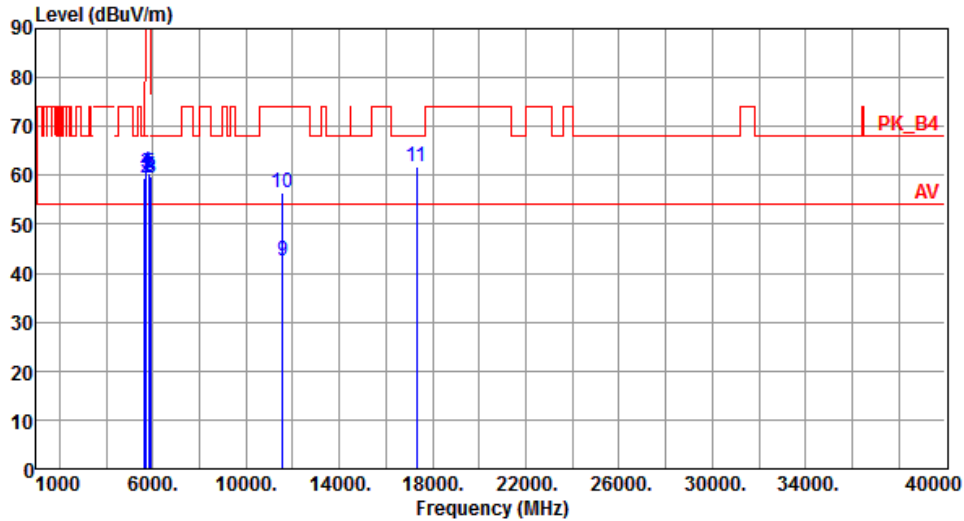

	Freq. MHz	Emission level dBuV/m	Limit dBuV/m	Margin dB	SA reading dBuV	Factor dB	Remark	ANT High cm	Turn Table deg
1	5650.00	59.51	68.20	-8.69	54.78	4.73	Peak	222	101
2	5700.00	59.50	105.20	-45.70	54.71	4.79	Peak	222	101
3	5720.00	60.51	110.80	-50.29	55.69	4.82	Peak	222	101
4	5725.00	60.70	122.20	-61.50	55.88	4.82	Peak	222	101
5	5850.00	60.33	122.20	-61.87	55.34	4.99	Peak	222	101
6	5855.00	59.91	110.80	-50.89	54.91	5.00	Peak	222	101
7	5875.00	59.72	105.20	-45.48	54.70	5.02	Peak	222	101
8	5925.00	59.32	68.20	-8.88	54.24	5.08	Peak	222	101
9	11550.00	42.60	54.00	-11.40	28.75	13.85	Average	100	98
10	11550.00	56.54	74.00	-17.46	42.69	13.85	Peak	100	98
11	17325.00	61.80	68.20	-6.40	43.52	18.28	Peak	100	13

Note 1: Emission Level (dBuV/m) = SA Reading (dBuV/m) + Factor* (dB)

*Factor includes antenna factor , cable loss and amplifier gain

Note 2: Margin (dB) = Emission level (dBuV/m) – Limit (dBuV/m).

Modulation	VHT80	Test Freq. (MHz)	5775
Polarization	Vertical		

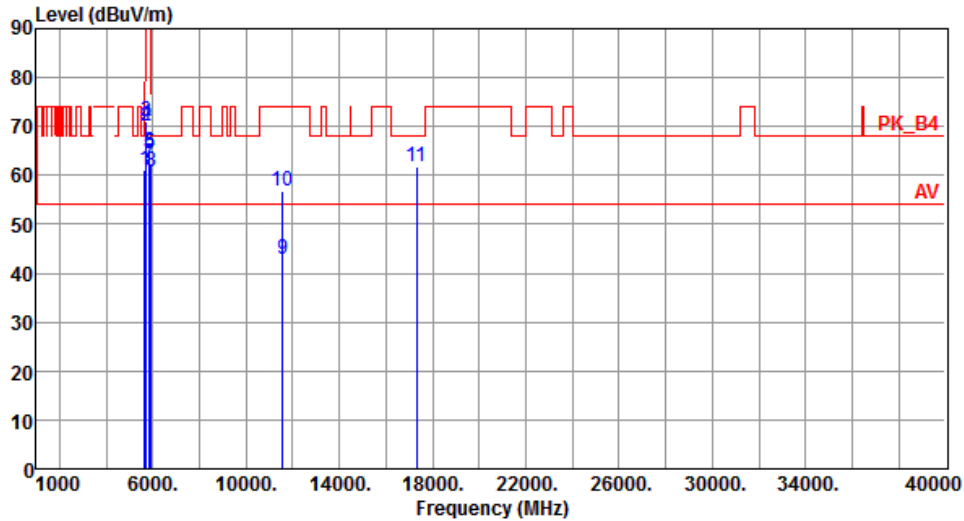

	Freq. MHz	Emission level dBuV/m	Limit dBuV/m	Margin dB	SA reading dBuV	Factor dB	Remark	ANT High cm	Turn Table deg
1	5650.00	60.96	68.20	-7.24	56.23	4.73	Peak	169	98
2	5700.00	70.05	105.20	-35.15	65.26	4.79	Peak	169	98
3	5720.00	71.11	110.80	-39.69	66.29	4.82	Peak	169	98
4	5725.00	70.42	122.20	-51.78	65.60	4.82	Peak	169	98
5	5850.00	64.29	122.20	-57.91	59.30	4.99	Peak	169	98
6	5855.00	64.85	110.80	-45.95	59.85	5.00	Peak	169	98
7	5875.00	62.44	105.20	-42.76	57.42	5.02	Peak	169	98
8	5925.00	60.79	68.20	-7.41	55.71	5.08	Peak	169	98
9	11550.00	42.72	54.00	-11.28	28.87	13.85	Average	100	101
10	11550.00	56.84	74.00	-17.16	42.99	13.85	Peak	100	101
11	17325.00	61.73	68.20	-6.47	43.45	18.28	Peak	100	111

Note 1: Emission Level (dBuV/m) = SA Reading (dBuV/m) + Factor* (dB)

*Factor includes antenna factor , cable loss and amplifier gain

Note 2: Margin (dB) = Emission level (dBuV/m) – Limit (dBuV/m).

Test Configuration 2

3.5.9 Transmitter Radiated Unwanted Emissions (Below 1GHz)

Modulation	VHT20	Test Freq. (MHz)	5240
Polarization	Horizontal		

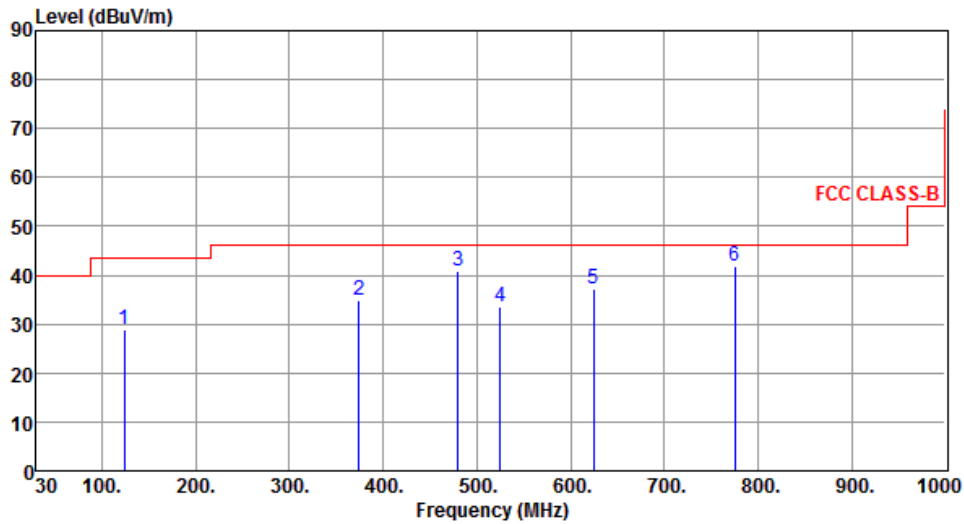

	Freq. MHz	Emission level dBuV/m	Limit dBuV/m	Margin dB	SA reading dBuV	Factor dB	Remark	ANT High cm	Turn Table deg
1	124.09	28.97	43.50	-14.53	39.23	-10.26	Peak	---	---
2	374.35	34.85	46.00	-11.15	40.81	-5.96	Peak	---	---
3	480.08	40.80	46.00	-5.20	44.38	-3.58	Peak	---	---
4	524.70	33.56	46.00	-12.44	36.31	-2.75	Peak	---	---
5	624.61	37.33	46.00	-8.67	37.78	-0.45	Peak	---	---
6	774.96	41.84	46.00	-4.16	39.79	2.05	Peak	---	---

Note 1: Emission Level (dBuV/m) = SA Reading (dBuV/m) + Factor* (dB)

*Factor includes antenna factor, cable loss and amplifier gain

Note 2: Margin (dB) = Emission level (dBuV/m) – Limit (dBuV/m).

Note 3: All spurious emissions below 30MHz are more than 20 dB below the limit.

Modulation	VHT20	Test Freq. (MHz)	5240
Polarization	Vertical		

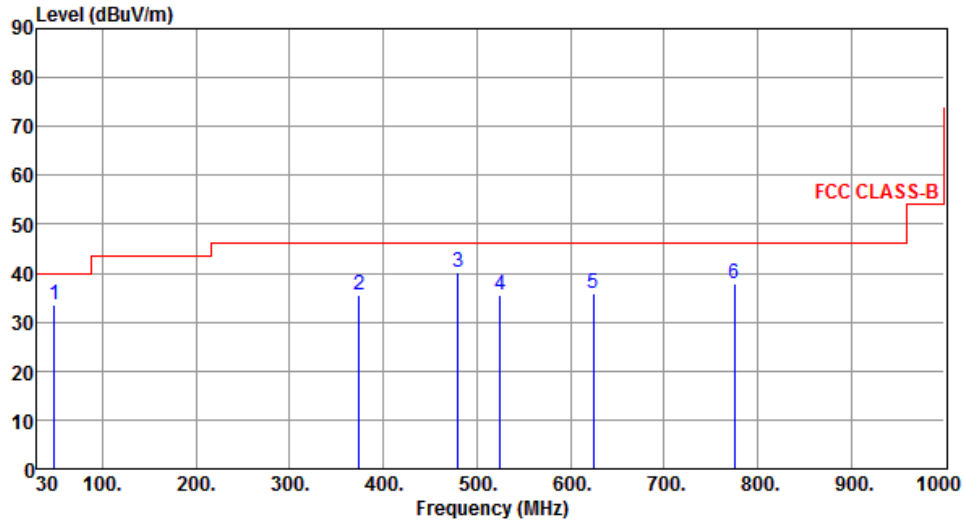

	Freq. MHz	Emission level dBuV/m	Limit dBuV/m	Margin dB	SA reading dBuV	Factor dB	Remark	ANT High cm	Turn Table deg
1	48.43	33.48	40.00	-6.52	41.51	-8.03	Peak	---	---
2	374.35	35.43	46.00	-10.57	41.39	-5.96	Peak	---	---
3	480.08	40.27	46.00	-5.73	43.85	-3.58	Peak	---	---
4	524.70	35.50	46.00	-10.50	38.25	-2.75	Peak	---	---
5	624.61	35.86	46.00	-10.14	36.31	-0.45	Peak	---	---
6	774.96	37.87	46.00	-8.13	35.82	2.05	Peak	---	---

Note 1: Emission Level (dBuV/m) = SA Reading (dBuV/m) + Factor* (dB)

*Factor includes antenna factor , cable loss and amplifier gain

Note 2: Margin (dB) = Emission level (dBuV/m) – Limit (dBuV/m).

Note 3: All spurious emissions below 30MHz are more than 20 dB below the limit.

Modulation	VHT20	Test Freq. (MHz)	5745
Polarization	Horizontal		

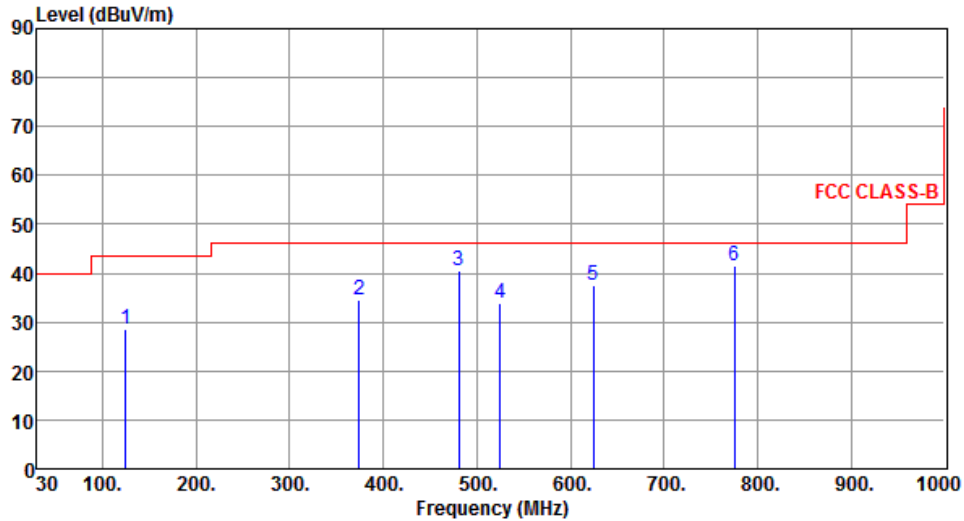

	Freq. MHz	Emission level dBuV/m	Limit dBuV/m	Margin dB	SA reading dBuV	Factor dB	Remark	ANT High cm	Turn Table deg
1	124.34	28.47	43.50	-15.03	38.70	-10.23	Peak	---	---
2	374.54	34.65	46.00	-11.35	40.60	-5.95	Peak	---	---
3	480.35	40.36	46.00	-5.64	43.94	-3.58	Peak	---	---
4	524.60	33.98	46.00	-12.02	36.74	-2.76	Peak	---	---
5	624.44	37.60	46.00	-8.40	38.05	-0.45	Peak	---	---
6	775.01	41.59	46.00	-4.41	39.53	2.06	Peak	---	---

Note 1: Emission Level (dBuV/m) = SA Reading (dBuV/m) + Factor* (dB)

*Factor includes antenna factor , cable loss and amplifier gain

Note 2: Margin (dB) = Emission level (dBuV/m) – Limit (dBuV/m).

Note 3: All spurious emissions below 30MHz are more than 20 dB below the limit.

Modulation	VHT20	Test Freq. (MHz)	5745
Polarization	Vertical		

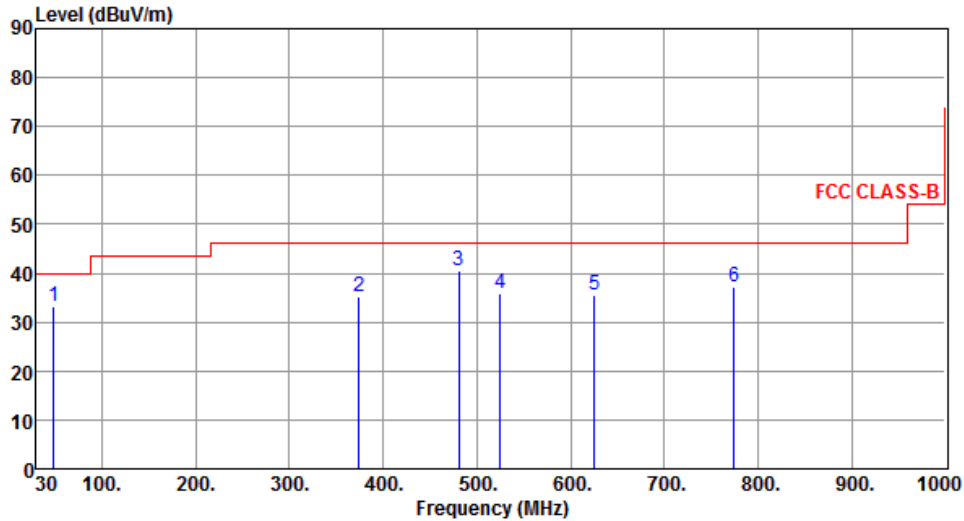

	Freq. MHz	Emission level dBuV/m	Limit dBuV/m	Margin dB	SA reading dBuV	Factor dB	Remark	ANT High cm	Turn Table deg
1	48.65	33.29	40.00	-6.71	41.31	-8.02	Peak	---	---
2	374.41	35.23	46.00	-10.77	41.18	-5.95	Peak	---	---
3	480.39	40.68	46.00	-5.32	44.26	-3.58	Peak	---	---
4	524.65	35.97	46.00	-10.03	38.73	-2.76	Peak	---	---
5	625.21	35.69	46.00	-10.31	36.13	-0.44	Peak	---	---
6	774.65	37.34	46.00	-8.66	35.29	2.05	Peak	---	---

Note 1: Emission Level (dBuV/m) = SA Reading (dBuV/m) + Factor* (dB)

*Factor includes antenna factor , cable loss and amplifier gain

Note 2: Margin (dB) = Emission level (dBuV/m) – Limit (dBuV/m).

Note 3: All spurious emissions below 30MHz are more than 20 dB below the limit.

3.5.10 Transmitter Radiated Unwanted Emissions (Above 1GHz) for 11a

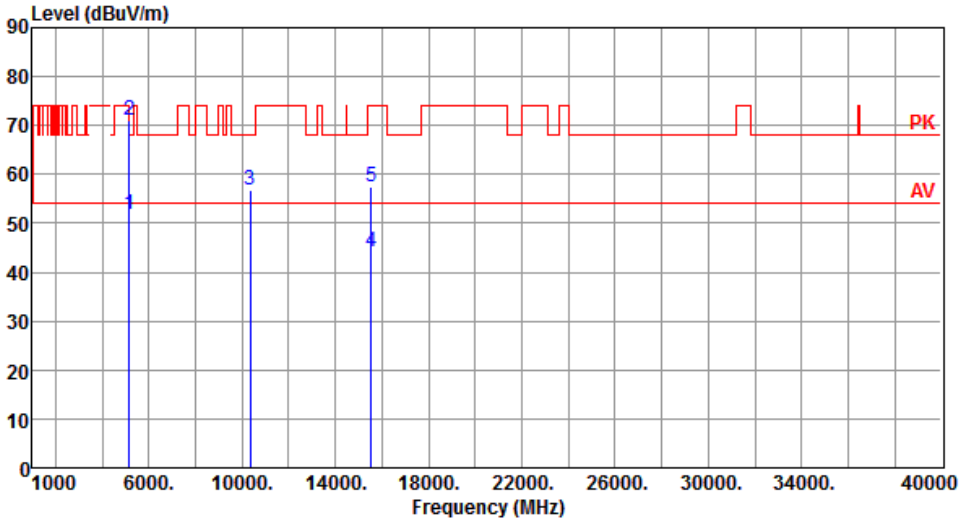
Modulation	11a	Test Freq. (MHz)	5180																																																																				
Polarization	Horizontal																																																																						
																																																																							
	<table border="1"> <thead> <tr> <th>Freq.</th> <th>Emission level</th> <th>Limit</th> <th>Margin</th> <th>SA reading</th> <th>Factor</th> <th>Remark</th> <th>ANT High</th> <th>Turn Table</th> </tr> <tr> <th>MHz</th> <th>dBuV/m</th> <th>dBuV/m</th> <th>dB</th> <th>dBuV</th> <th>dB</th> <th></th> <th>cm</th> <th>deg</th> </tr> </thead> <tbody> <tr> <td>1</td> <td>5150.00</td> <td>51.74</td> <td>54.00</td> <td>-2.26</td> <td>47.50</td> <td>4.24</td> <td>Average</td> <td>332</td> </tr> <tr> <td>2</td> <td>5150.00</td> <td>71.02</td> <td>74.00</td> <td>-2.98</td> <td>66.78</td> <td>4.24</td> <td>Peak</td> <td>209</td> </tr> <tr> <td>3</td> <td>10360.00</td> <td>56.90</td> <td>68.20</td> <td>-11.30</td> <td>43.21</td> <td>13.69</td> <td>Peak</td> <td>158</td> </tr> <tr> <td>4</td> <td>15540.00</td> <td>44.26</td> <td>54.00</td> <td>-9.74</td> <td>29.57</td> <td>14.69</td> <td>Average</td> <td>7</td> </tr> <tr> <td>5</td> <td>15540.00</td> <td>57.35</td> <td>74.00</td> <td>-16.65</td> <td>42.66</td> <td>14.69</td> <td>Peak</td> <td>100</td> </tr> </tbody> </table>	Freq.	Emission level	Limit	Margin	SA reading	Factor	Remark	ANT High	Turn Table	MHz	dBuV/m	dBuV/m	dB	dBuV	dB		cm	deg	1	5150.00	51.74	54.00	-2.26	47.50	4.24	Average	332	2	5150.00	71.02	74.00	-2.98	66.78	4.24	Peak	209	3	10360.00	56.90	68.20	-11.30	43.21	13.69	Peak	158	4	15540.00	44.26	54.00	-9.74	29.57	14.69	Average	7	5	15540.00	57.35	74.00	-16.65	42.66	14.69	Peak	100							
Freq.	Emission level	Limit	Margin	SA reading	Factor	Remark	ANT High	Turn Table																																																															
MHz	dBuV/m	dBuV/m	dB	dBuV	dB		cm	deg																																																															
1	5150.00	51.74	54.00	-2.26	47.50	4.24	Average	332																																																															
2	5150.00	71.02	74.00	-2.98	66.78	4.24	Peak	209																																																															
3	10360.00	56.90	68.20	-11.30	43.21	13.69	Peak	158																																																															
4	15540.00	44.26	54.00	-9.74	29.57	14.69	Average	7																																																															
5	15540.00	57.35	74.00	-16.65	42.66	14.69	Peak	100																																																															
<p>Note 1: Emission Level (dBuV/m) = SA Reading (dBuV/m) + Factor* (dB) *Factor includes antenna factor , cable loss and amplifier gain Note 2: Margin (dB) = Emission level (dBuV/m) – Limit (dBuV/m).</p>																																																																							

Modulation	11a	Test Freq. (MHz)	5180
Polarization	Vertical		

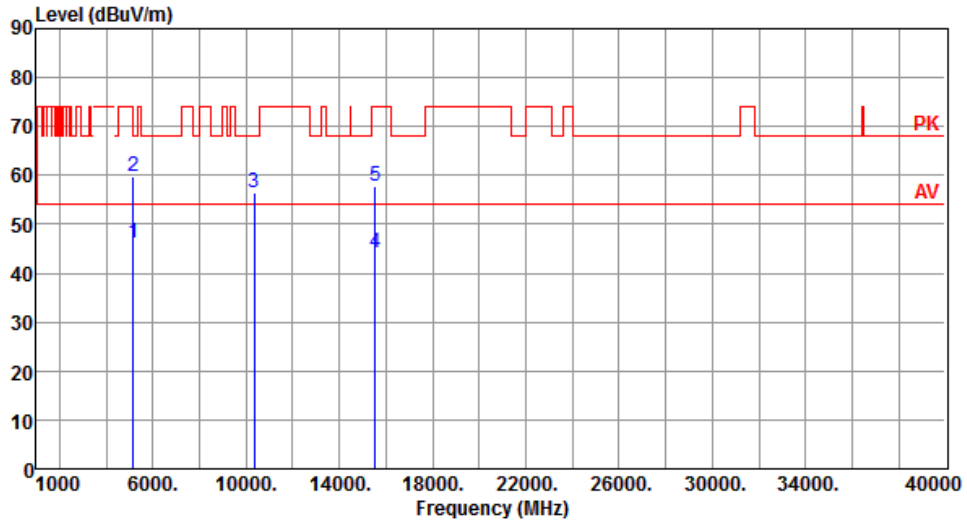

	Freq. MHz	Emission level dBuV/m	Limit dBuV/m	Margin dB	SA reading dBuV	Factor dB	Remark	ANT High cm	Turn Table deg
1	5150.00	46.33	54.00	-7.67	42.09	4.24	Average	100	29
2	5150.00	59.77	74.00	-14.23	55.53	4.24	Peak	100	29
3	10360.00	56.36	68.20	-11.84	42.67	13.69	Peak	100	239
4	15540.00	44.10	54.00	-9.90	29.41	14.69	Average	100	31
5	15540.00	57.93	74.00	-16.07	43.24	14.69	Peak	100	31

Note 1: Emission Level (dBuV/m) = SA Reading (dBuV/m) + Factor* (dB)

*Factor includes antenna factor , cable loss and amplifier gain

Note 2: Margin (dB) = Emission level (dBuV/m) – Limit (dBuV/m).

Modulation	11a	Test Freq. (MHz)	5200
Polarization	Horizontal		

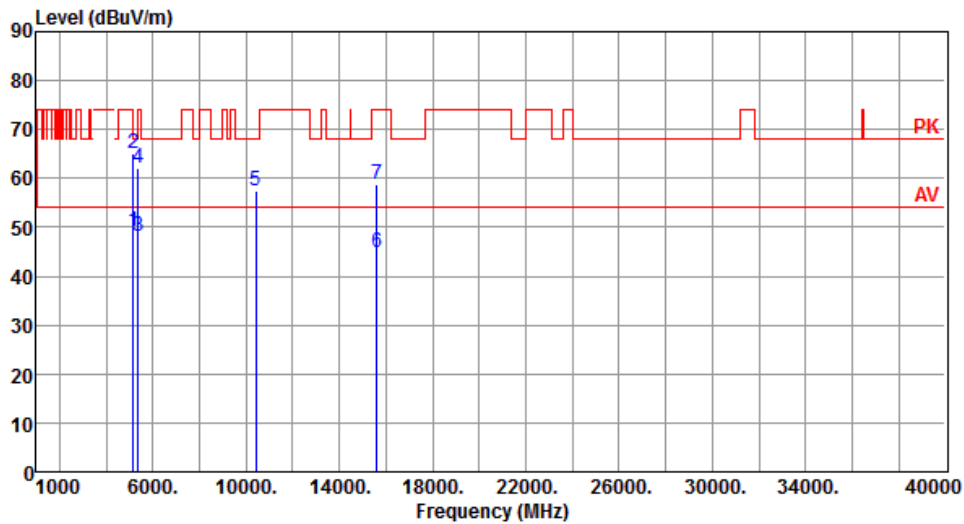

	Freq. MHz	Emission level dBuV/m	Limit dBuV/m	Margin dB	SA reading dBuV	Factor dB	Remark	ANT High cm	Turn Table deg
1	5150.00	49.00	54.00	-5.00	44.76	4.24	Average	227	351
2	5150.00	65.16	74.00	-8.84	60.92	4.24	Peak	227	351
3	5350.00	48.31	54.00	-5.69	43.88	4.43	Average	227	351
4	5350.00	61.99	74.00	-12.01	57.56	4.43	Peak	227	351
5	10400.00	57.45	68.20	-10.75	43.74	13.71	Peak	208	38
6	15600.00	44.77	54.00	-9.23	30.12	14.65	Average	100	2
7	15600.00	58.84	74.00	-15.16	44.19	14.65	Peak	100	2

Note 1: Emission Level (dBuV/m) = SA Reading (dBuV/m) + Factor* (dB)

*Factor includes antenna factor , cable loss and amplifier gain

Note 2: Margin (dB) = Emission level (dBuV/m) – Limit (dBuV/m).

Modulation	11a	Test Freq. (MHz)	5200
Polarization	Vertical		

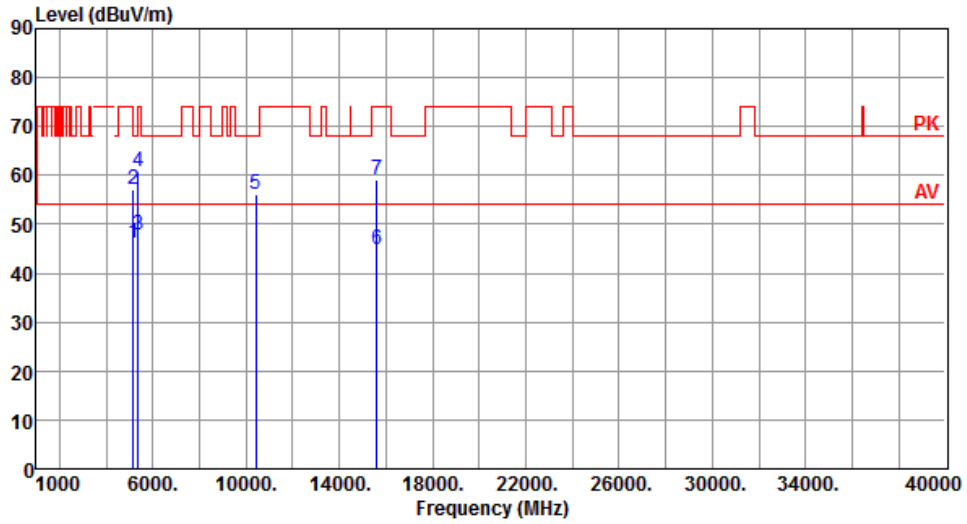

	Freq. MHz	Emission level dBuV/m	Limit dBuV/m	Margin dB	SA reading dBuV	Factor dB	Remark	ANT High cm	Turn Table deg
1	5150.00	46.03	54.00	-7.97	41.79	4.24	Average	100	28
2	5150.00	57.29	74.00	-16.71	53.05	4.24	Peak	100	28
3	5350.00	47.69	54.00	-6.31	43.26	4.43	Average	100	28
4	5350.00	60.65	74.00	-13.35	56.22	4.43	Peak	100	28
5	10400.00	56.22	68.20	-11.98	42.51	13.71	Peak	154	245
6	15600.00	44.85	54.00	-9.15	30.20	14.65	Average	100	36
7	15600.00	59.10	74.00	-14.90	44.45	14.65	Peak	100	36

Note 1: Emission Level (dBuV/m) = SA Reading (dBuV/m) + Factor* (dB)

*Factor includes antenna factor , cable loss and amplifier gain

Note 2: Margin (dB) = Emission level (dBuV/m) – Limit (dBuV/m).

Modulation	11a	Test Freq. (MHz)	5240
Polarization	Horizontal		

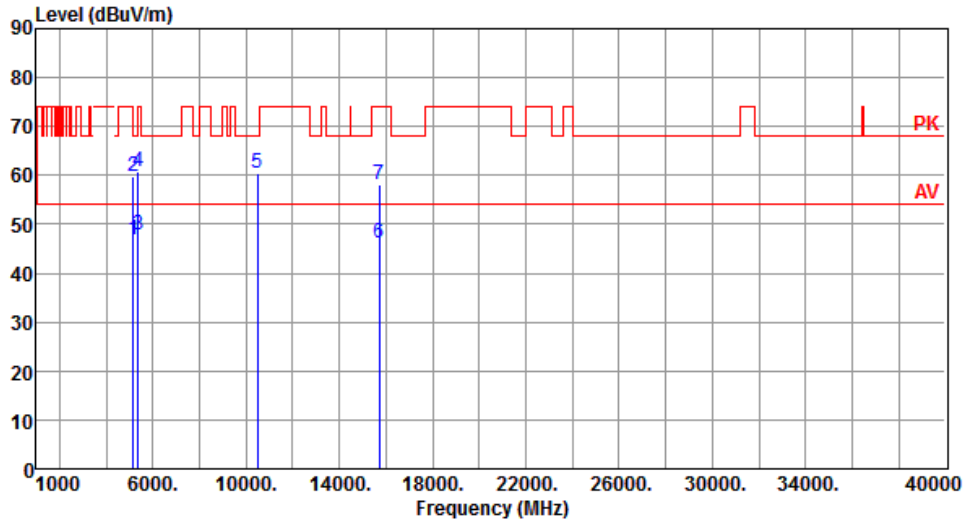

	Freq. MHz	Emission level dBuV/m	Limit dBuV/m	Margin dB	SA reading dBuV	Factor dB	Remark	ANT High cm	Turn Table deg
1	5150.00	46.78	54.00	-7.22	42.54	4.24	Average	203	345
2	5150.00	59.93	74.00	-14.07	55.69	4.24	Peak	203	345
3	5350.00	47.97	54.00	-6.03	43.54	4.43	Average	203	345
4	5350.00	60.71	74.00	-13.29	56.28	4.43	Peak	203	345
5	10480.00	60.56	68.20	-7.64	46.82	13.74	Peak	158	47
6	15720.00	46.01	54.00	-7.99	31.43	14.58	Average	100	11
7	15720.00	58.27	74.00	-15.73	43.69	14.58	Peak	100	11

Note 1: Emission Level (dBuV/m) = SA Reading (dBuV/m) + Factor* (dB)

*Factor includes antenna factor , cable loss and amplifier gain

Note 2: Margin (dB) = Emission level (dBuV/m) – Limit (dBuV/m).

Modulation	11a	Test Freq. (MHz)	5240
Polarization	Vertical		

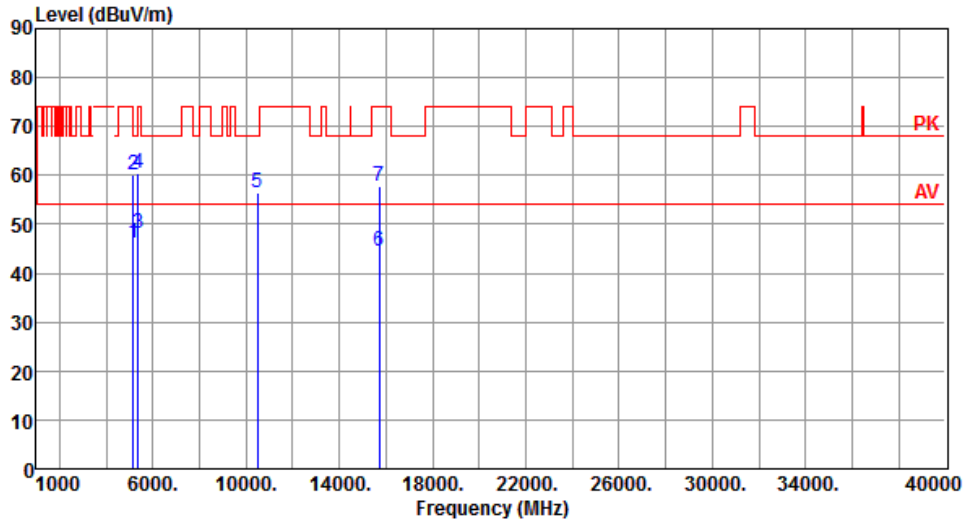

	Freq. MHz	Emission level dBuV/m	Limit dBuV/m	Margin dB	SA reading dBuV	Factor dB	Remark	ANT High cm	Turn Table deg
1	5150.00	46.24	54.00	-7.76	42.00	4.24	Average	100	25
2	5150.00	59.98	74.00	-14.02	55.74	4.24	Peak	100	25
3	5350.00	47.99	54.00	-6.01	43.56	4.43	Average	100	25
4	5350.00	60.56	74.00	-13.44	56.13	4.43	Peak	100	25
5	10480.00	56.35	68.20	-11.85	42.61	13.74	Peak	100	235
6	15720.00	44.45	54.00	-9.55	29.87	14.58	Average	100	34
7	15720.00	57.85	74.00	-16.15	43.27	14.58	Peak	100	34

Note 1: Emission Level (dBuV/m) = SA Reading (dBuV/m) + Factor* (dB)

*Factor includes antenna factor , cable loss and amplifier gain

Note 2: Margin (dB) = Emission level (dBuV/m) – Limit (dBuV/m).

Modulation	11a	Test Freq. (MHz)	5260
Polarization	Horizontal		

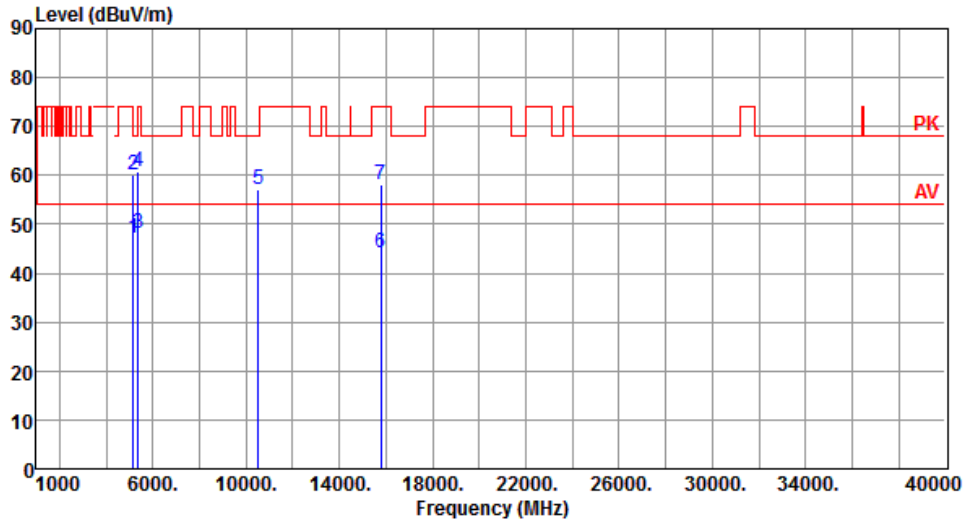

	Freq. MHz	Emission level dBuV/m	Limit dBuV/m	Margin dB	SA reading dBuV	Factor dB	Remark	ANT High cm	Turn Table deg
1	5150.00	47.03	54.00	-6.97	42.79	4.24	Average	208	347
2	5150.00	60.10	74.00	-13.90	55.86	4.24	Peak	208	347
3	5350.00	48.21	54.00	-5.79	43.78	4.43	Average	208	347
4	5350.00	60.83	74.00	-13.17	56.40	4.43	Peak	208	347
5	10520.00	57.21	68.20	-10.99	43.44	13.77	Peak	171	37
6	15780.00	44.22	54.00	-9.78	29.67	14.55	Average	171	37
7	15780.00	58.07	74.00	-15.93	43.52	14.55	Peak	171	37

Note 1: Emission Level (dBuV/m) = SA Reading (dBuV/m) + Factor* (dB)

*Factor includes antenna factor , cable loss and amplifier gain

Note 2: Margin (dB) = Emission level (dBuV/m) – Limit (dBuV/m).

Modulation	11a	Test Freq. (MHz)	5260
Polarization	Vertical		

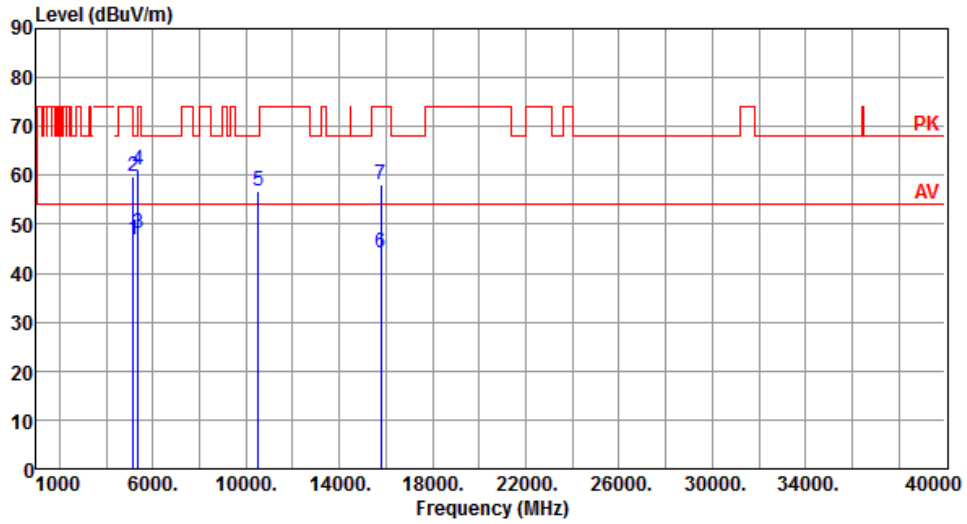

	Freq. MHz	Emission level dBuV/m	Limit dBuV/m	Margin dB	SA reading dBuV	Factor dB	Remark	ANT High cm	Turn Table deg
1	5150.00	46.88	54.00	-7.12	42.64	4.24	Average	100	25
2	5150.00	59.69	74.00	-14.31	55.45	4.24	Peak	100	25
3	5350.00	48.08	54.00	-5.92	43.65	4.43	Average	100	25
4	5350.00	60.99	74.00	-13.01	56.56	4.43	Peak	100	25
5	10520.00	56.72	68.20	-11.48	42.95	13.77	Peak	100	241
6	15780.00	44.10	54.00	-9.90	29.55	14.55	Average	100	41
7	15780.00	58.13	74.00	-15.87	43.58	14.55	Peak	100	41

Note 1: Emission Level (dBuV/m) = SA Reading (dBuV/m) + Factor* (dB)

*Factor includes antenna factor , cable loss and amplifier gain

Note 2: Margin (dB) = Emission level (dBuV/m) – Limit (dBuV/m).

Modulation	11a	Test Freq. (MHz)	5300
Polarization	Horizontal		

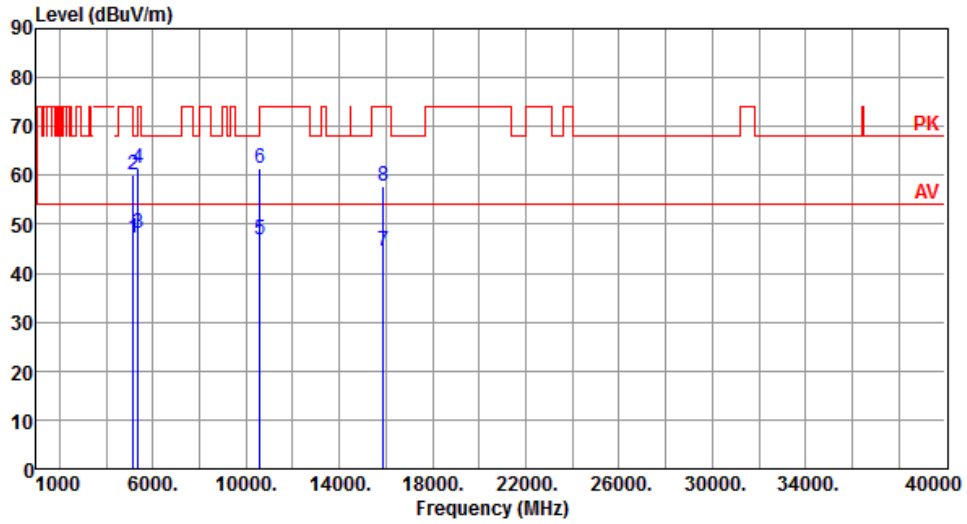

	Freq. MHz	Emission level dBuV/m	Limit dBuV/m	Margin dB	SA reading dBuV	Factor dB	Remark	ANT High cm	Turn Table deg
1	5150.00	47.08	54.00	-6.92	42.84	4.24	Average	213	351
2	5150.00	60.13	74.00	-13.87	55.89	4.24	Peak	213	351
3	5350.00	48.31	54.00	-5.69	43.88	4.43	Average	100	355
4	5350.00	61.40	74.00	-12.60	56.97	4.43	Peak	100	355
5	10600.00	46.90	54.00	-7.10	33.03	13.87	Average	169	44
6	10600.00	61.28	74.00	-12.72	47.41	13.87	Peak	169	44
7	15900.00	44.60	54.00	-9.40	30.12	14.48	Average	100	355
8	15900.00	57.72	74.00	-16.28	43.24	14.48	Peak	100	355

Note 1: Emission Level (dBuV/m) = SA Reading (dBuV/m) + Factor* (dB)

*Factor includes antenna factor , cable loss and amplifier gain

Note 2: Margin (dB) = Emission level (dBuV/m) – Limit (dBuV/m).

Modulation	11a	Test Freq. (MHz)	5300
Polarization	Vertical		

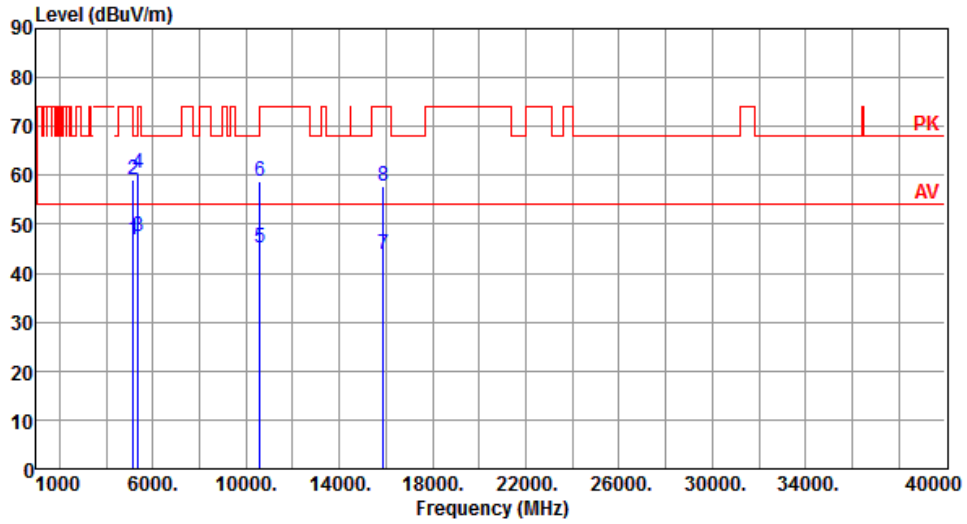

	Freq. MHz	Emission level dBuV/m	Limit dBuV/m	Margin dB	SA reading dBuV	Factor dB	Remark	ANT High cm	Turn Table deg
1	5150.00	46.81	54.00	-7.19	42.57	4.24	Average	100	27
2	5150.00	59.24	74.00	-14.76	55.00	4.24	Peak	100	27
3	5350.00	47.44	54.00	-6.56	43.01	4.43	Average	100	27
4	5350.00	60.53	74.00	-13.47	56.10	4.43	Peak	100	27
5	10600.00	45.28	54.00	-8.72	31.41	13.87	Average	100	242
6	10600.00	58.67	74.00	-15.33	44.80	13.87	Peak	100	242
7	15900.00	43.89	54.00	-10.11	29.41	14.48	Average	100	33
8	15900.00	57.72	74.00	-16.28	43.24	14.48	Peak	100	33

Note 1: Emission Level (dBuV/m) = SA Reading (dBuV/m) + Factor* (dB)

*Factor includes antenna factor , cable loss and amplifier gain

Note 2: Margin (dB) = Emission level (dBuV/m) – Limit (dBuV/m).

Modulation	11a	Test Freq. (MHz)	5320
Polarization	Horizontal		

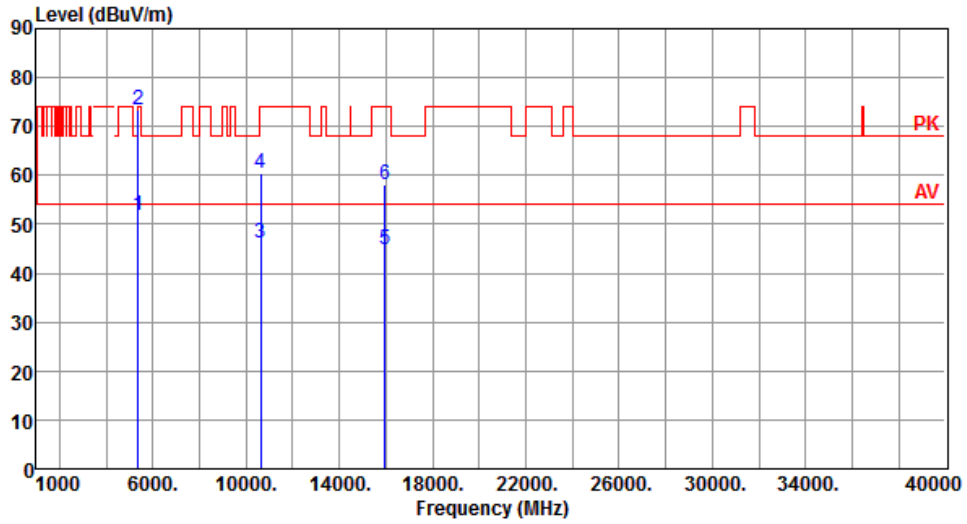

	Freq. MHz	Emission level dBuV/m	Limit dBuV/m	Margin dB	SA reading dBuV	Factor dB	Remark	ANT High cm	Turn Table deg
1	5350.00	51.80	54.00	-2.20	47.37	4.43	Average	214	330
2	5350.00	73.49	74.00	-0.51	69.06	4.43	Peak	214	330
3	10640.00	46.21	54.00	-7.79	32.29	13.92	Average	210	37
4	10640.00	60.49	74.00	-13.51	46.57	13.92	Peak	210	37
5	15960.00	44.67	54.00	-9.33	30.23	14.44	Average	100	3
6	15960.00	58.01	74.00	-15.99	43.57	14.44	Peak	100	3

Note 1: Emission Level (dBuV/m) = SA Reading (dBuV/m) + Factor* (dB)

*Factor includes antenna factor , cable loss and amplifier gain

Note 2: Margin (dB) = Emission level (dBuV/m) – Limit (dBuV/m).

Modulation	11a	Test Freq. (MHz)	5320
Polarization	Vertical		

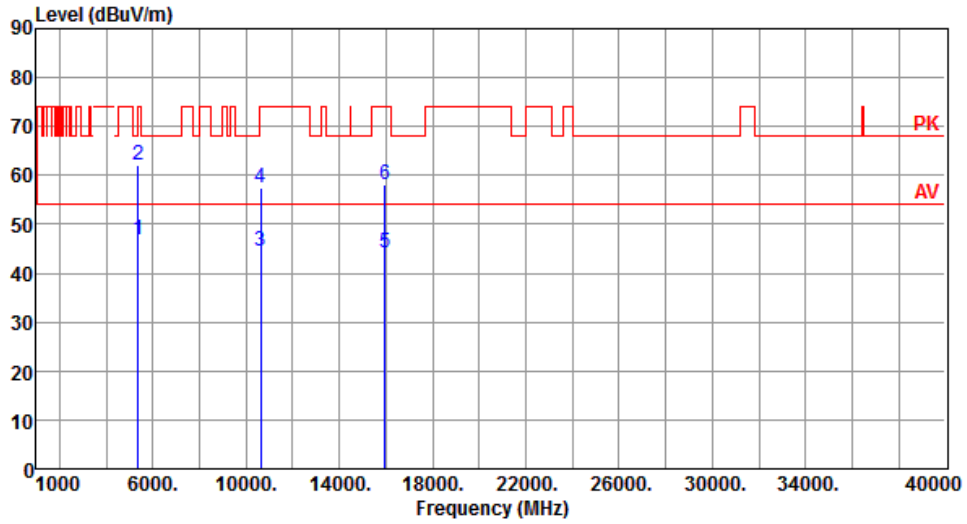

	Freq. MHz	Emission level dBuV/m	Limit dBuV/m	Margin dB	SA reading dBuV	Factor dB	Remark	ANT High cm	Turn Table deg
1	5350.00	46.88	54.00	-7.12	42.45	4.43	Average	100	24
2	5350.00	62.24	74.00	-11.76	57.81	4.43	Peak	100	24
3	10640.00	44.61	54.00	-9.39	30.69	13.92	Average	100	245
4	10640.00	57.52	74.00	-16.48	43.60	13.92	Peak	100	245
5	15960.00	44.02	54.00	-9.98	29.58	14.44	Average	100	37
6	15960.00	58.01	74.00	-15.99	43.57	14.44	Peak	100	37

Note 1: Emission Level (dBuV/m) = SA Reading (dBuV/m) + Factor* (dB)

*Factor includes antenna factor , cable loss and amplifier gain

Note 2: Margin (dB) = Emission level (dBuV/m) – Limit (dBuV/m).

Modulation	11a	Test Freq. (MHz)	5500
Polarization	Horizontal		

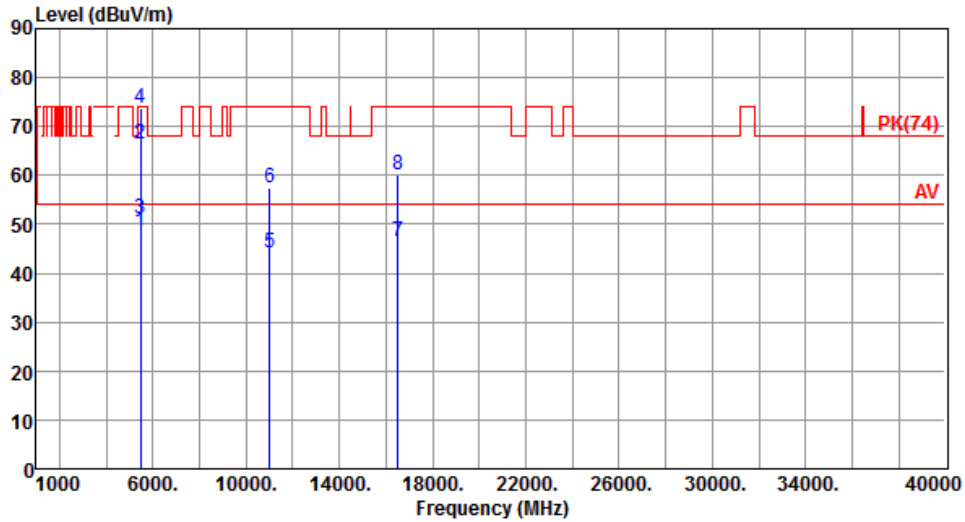

	Freq. MHz	Emission level dBuV/m	Limit dBuV/m	Margin dB	SA reading dBuV	Factor dB	Remark	ANT High cm	Turn Table deg
1	5460.00	48.54	54.00	-5.46	44.03	4.51	Average	209	346
2	5460.00	66.32	74.00	-7.68	61.81	4.51	Peak	209	346
3	5470.00	51.02	54.00	-2.98	46.50	4.52	Average	209	346
4	5470.00	73.88	74.00	-0.12	69.36	4.52	Peak	209	346
5	11000.00	44.18	54.00	-9.82	29.84	14.34	Average	100	42
6	11000.00	57.59	74.00	-16.41	43.25	14.34	Peak	100	42
7	16500.00	46.42	54.00	-7.58	29.94	16.48	Average	100	348
8	16500.00	60.16	74.00	-13.84	43.68	16.48	Peak	100	348

Note 1: Emission Level (dBuV/m) = SA Reading (dBuV/m) + Factor* (dB)

*Factor includes antenna factor , cable loss and amplifier gain

Note 2: Margin (dB) = Emission level (dBuV/m) – Limit (dBuV/m).

Modulation	11a	Test Freq. (MHz)	5500
Polarization	Vertical		

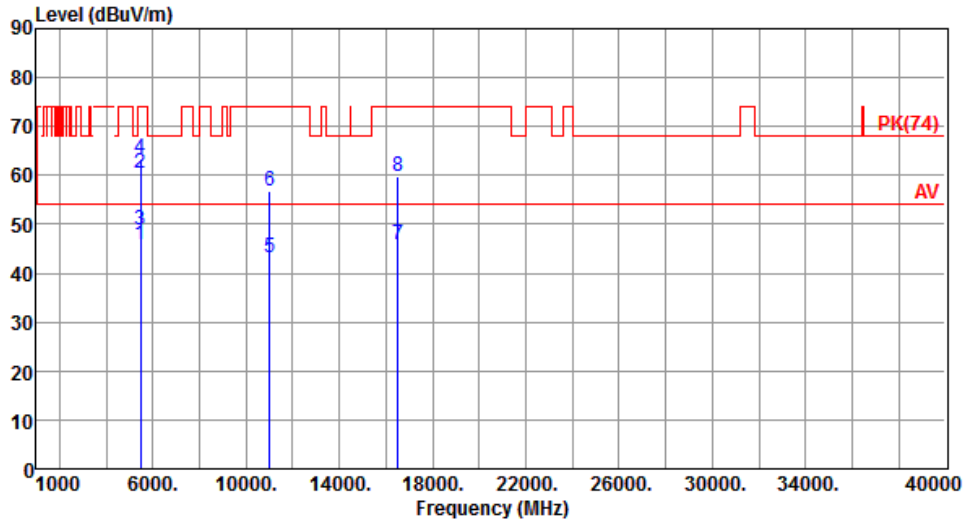

	Freq. MHz	Emission level dBuV/m	Limit dBuV/m	Margin dB	SA reading dBuV	Factor dB	Remark	ANT High cm	Turn Table deg
1	5460.00	45.75	54.00	-8.25	41.24	4.51	Average	100	31
2	5460.00	60.38	74.00	-13.62	55.87	4.51	Peak	100	31
3	5470.00	48.73	54.00	-5.27	44.21	4.52	Average	100	31
4	5470.00	63.38	74.00	-10.62	58.86	4.52	Peak	100	31
5	11000.00	43.23	54.00	-10.77	28.89	14.34	Average	100	251
6	11000.00	56.91	74.00	-17.09	42.57	14.34	Peak	100	251
7	16500.00	45.92	54.00	-8.08	29.44	16.48	Average	100	251
8	16500.00	59.68	74.00	-14.32	43.20	16.48	Peak	100	251

Note 1: Emission Level (dBuV/m) = SA Reading (dBuV/m) + Factor* (dB)

*Factor includes antenna factor , cable loss and amplifier gain

Note 2: Margin (dB) = Emission level (dBuV/m) – Limit (dBuV/m).

Modulation	11a	Test Freq. (MHz)	5580
Polarization	Horizontal		

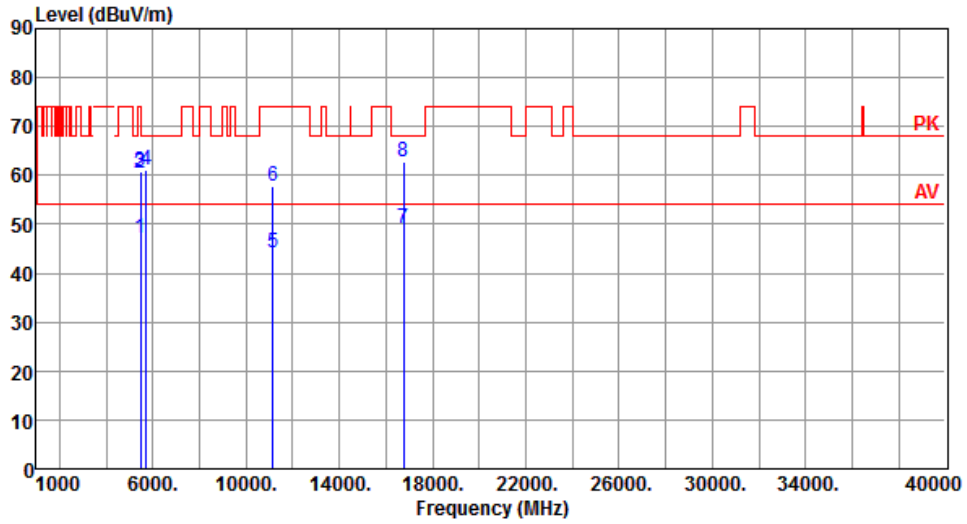

	Freq. MHz	Emission level dBuV/m	Limit dBuV/m	Margin dB	SA reading dBuV	Factor dB	Remark	ANT High cm	Turn Table deg
1	5460.00	47.32	54.00	-6.68	42.81	4.51	Average	194	351
2	5460.00	60.39	74.00	-13.61	55.88	4.51	Peak	194	351
3	5470.00	60.66	68.20	-7.54	56.14	4.52	Peak	194	351
4	5725.00	61.12	68.20	-7.08	56.30	4.82	Peak	194	351
5	11160.00	44.22	54.00	-9.78	30.02	14.20	Average	164	41
6	11160.00	57.72	74.00	-16.28	43.52	14.20	Peak	164	41
7	16740.00	49.11	54.00	-4.89	32.19	16.92	Average	132	338
8	16740.00	62.87	68.20	-5.33	45.95	16.92	Peak	132	338

Note 1: Emission Level (dBuV/m) = SA Reading (dBuV/m) + Factor* (dB)

*Factor includes antenna factor , cable loss and amplifier gain

Note 2: Margin (dB) = Emission level (dBuV/m) – Limit (dBuV/m).

Modulation	11a	Test Freq. (MHz)	5580
Polarization	Vertical		

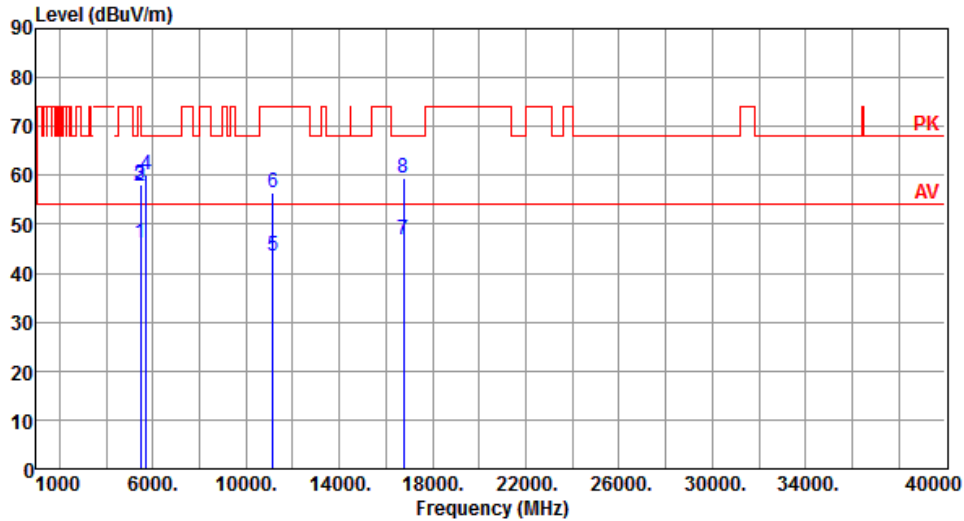

	Freq. MHz	Emission level dBuV/m	Limit dBuV/m	Margin dB	SA reading dBuV	Factor dB	Remark	ANT High cm	Turn Table deg
1	5460.00	46.02	54.00	-7.98	41.51	4.51	Average	100	21
2	5460.00	57.76	74.00	-16.24	53.25	4.51	Peak	100	21
3	5470.00	58.17	68.20	-10.03	53.65	4.52	Peak	100	21
4	5725.00	59.97	68.20	-8.23	55.15	4.82	Peak	100	21
5	11160.00	43.50	54.00	-10.50	29.30	14.20	Average	100	238
6	11160.00	56.38	74.00	-17.62	42.18	14.20	Peak	100	238
7	16740.00	46.79	54.00	-7.21	29.87	16.92	Average	100	34
8	16740.00	59.61	68.20	-8.59	42.69	16.92	Peak	100	34

Note 1: Emission Level (dBuV/m) = SA Reading (dBuV/m) + Factor* (dB)

*Factor includes antenna factor , cable loss and amplifier gain

Note 2: Margin (dB) = Emission level (dBuV/m) – Limit (dBuV/m).

Modulation	11a	Test Freq. (MHz)	5700
Polarization	Horizontal		

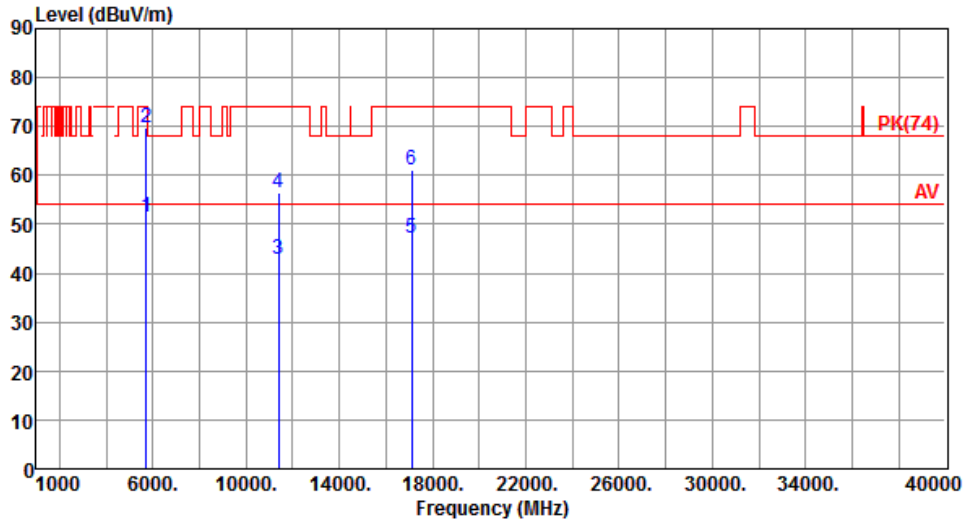

	Freq. MHz	Emission level dBuV/m	Limit dBuV/m	Margin dB	SA reading dBuV	Factor dB	Remark	ANT High cm	Turn Table deg
1	5725.00	51.63	54.00	-2.37	46.81	4.82	Average	219	335
2	5725.00	69.74	74.00	-4.26	64.92	4.82	Peak	219	351
3	11400.00	42.80	54.00	-11.20	28.80	14.00	Average	100	35
4	11400.00	56.47	74.00	-17.53	42.47	14.00	Peak	100	35
5	17100.00	47.16	54.00	-6.84	29.49	17.67	Average	100	339
6	17100.00	60.99	74.00	-13.01	43.32	17.67	Peak	100	339

Note 1: Emission Level (dBuV/m) = SA Reading (dBuV/m) + Factor* (dB)

*Factor includes antenna factor , cable loss and amplifier gain

Note 2: Margin (dB) = Emission level (dBuV/m) – Limit (dBuV/m).

Modulation	11a	Test Freq. (MHz)	5700
Polarization	Vertical		

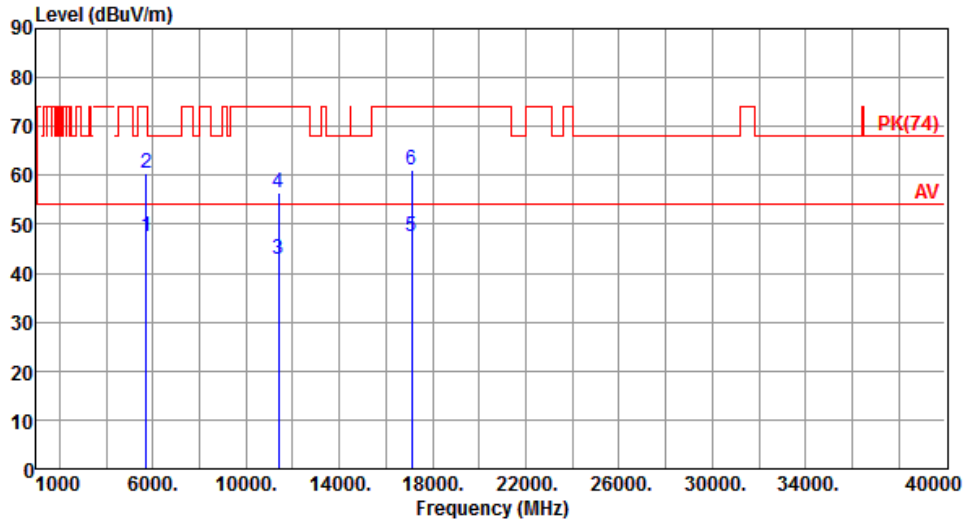

	Freq. MHz	Emission level dBuV/m	Limit dBuV/m	Margin dB	SA reading dBuV	Factor dB	Remark	ANT High cm	Turn Table deg
1	5725.00	47.38	54.00	-6.62	42.56	4.82	Average	100	23
2	5725.00	60.36	74.00	-13.64	55.54	4.82	Peak	100	23
3	11400.00	42.95	54.00	-11.05	28.95	14.00	Average	100	239
4	11400.00	56.56	74.00	-17.44	42.56	14.00	Peak	100	239
5	17100.00	47.33	54.00	-6.67	29.66	17.67	Average	100	36
6	17100.00	61.26	74.00	-12.74	43.59	17.67	Peak	100	36

Note 1: Emission Level (dBuV/m) = SA Reading (dBuV/m) + Factor* (dB)

*Factor includes antenna factor , cable loss and amplifier gain

Note 2: Margin (dB) = Emission level (dBuV/m) – Limit (dBuV/m).

Modulation	11a	Test Freq. (MHz)	5720
-------------------	-----	-------------------------	------

Polarization	Horizontal
---------------------	------------

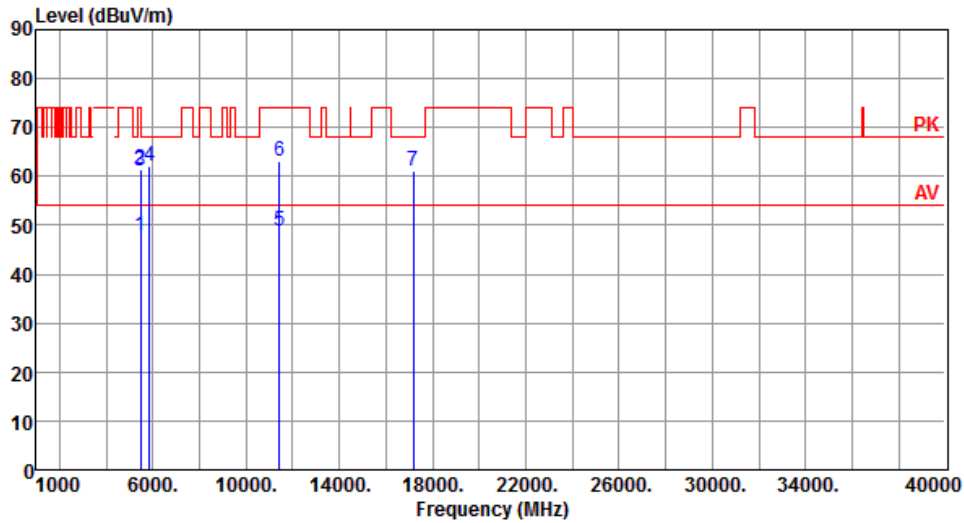

	Freq. MHz	Emission level dBuV/m	Limit dBuV/m	Margin dB	SA reading dBuV	Factor dB	Remark	ANT High cm	Turn Table deg
1	5460.00	47.73	54.00	-6.27	43.22	4.51	Average	205	191
2	5460.00	61.44	74.00	-12.56	56.93	4.51	Peak	205	191
3	5470.00	60.97	68.20	-7.23	56.45	4.52	Peak	205	191
4	5850.00	62.10	68.20	-6.10	57.11	4.99	Peak	205	191
5	11440.00	48.69	54.00	-5.31	34.73	13.96	Average	170	338
6	11440.00	62.97	74.00	-11.03	49.01	13.96	Peak	170	338
7	17160.00	61.09	68.20	-7.11	43.26	17.83	Peak	100	196

Note 1: Emission Level (dBuV/m) = SA Reading (dBuV/m) + Factor* (dB)

*Factor includes antenna factor , cable loss and amplifier gain

Note 2: Margin (dB) = Emission level (dBuV/m) – Limit (dBuV/m).

Modulation	11a	Test Freq. (MHz)	5720
Polarization	Vertical		

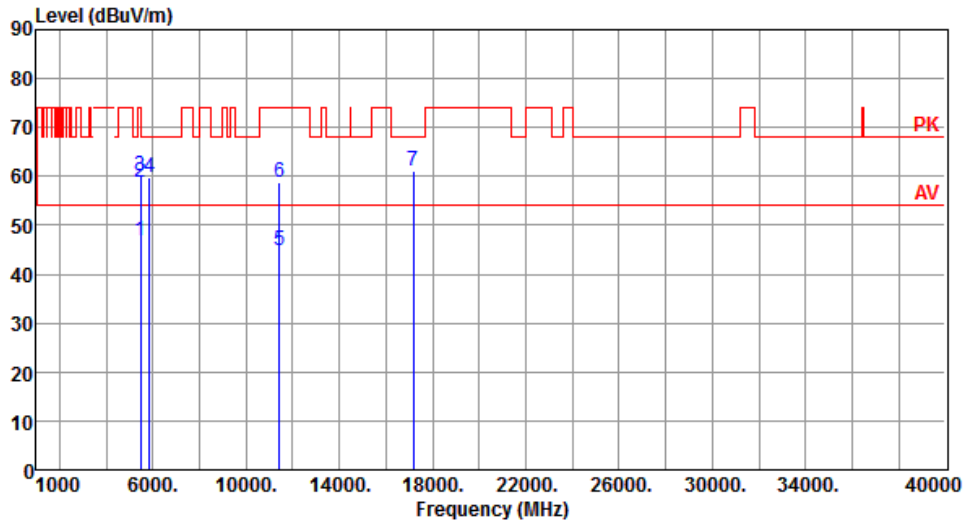

	Freq. MHz	Emission level dBuV/m	Limit dBuV/m	Margin dB	SA reading dBuV	Factor dB	Remark	ANT High cm	Turn Table deg
1	5460.00	46.87	54.00	-7.13	42.36	4.51	Average	191	265
2	5460.00	58.90	74.00	-15.10	54.39	4.51	Peak	191	265
3	5470.00	60.04	68.20	-8.16	55.52	4.52	Peak	191	265
4	5850.00	59.76	68.20	-8.44	54.77	4.99	Peak	191	265
5	11440.00	44.69	54.00	-9.31	30.73	13.96	Average	285	174
6	11440.00	58.87	74.00	-15.13	44.91	13.96	Peak	285	174
7	17160.00	61.08	68.20	-7.12	43.25	17.83	Peak	100	269

Note 1: Emission Level (dBuV/m) = SA Reading (dBuV/m) + Factor* (dB)

*Factor includes antenna factor , cable loss and amplifier gain

Note 2: Margin (dB) = Emission level (dBuV/m) – Limit (dBuV/m).

Modulation	11a	Test Freq. (MHz)	5745
Polarization	Horizontal		

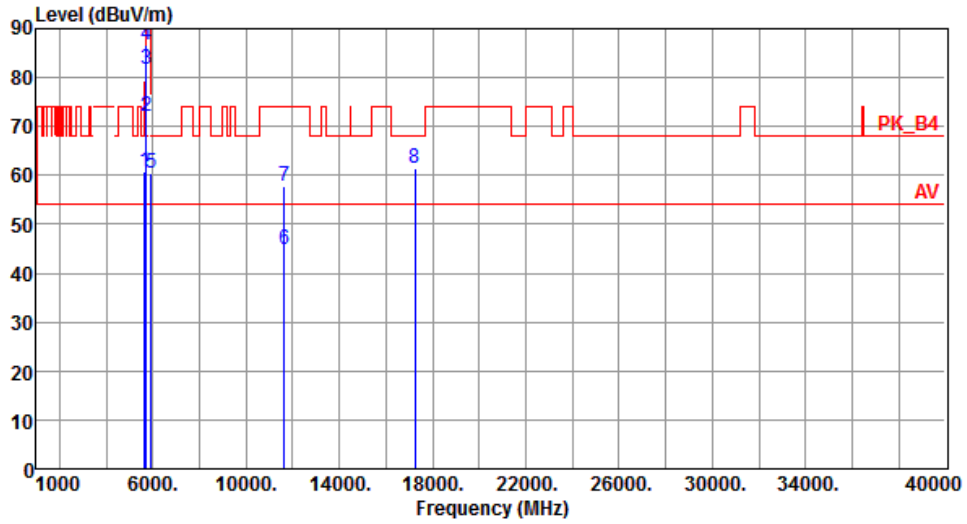

	Freq. MHz	Emission level dBuV/m	Limit dBuV/m	Margin dB	SA reading dBuV	Factor dB	Remark	ANT High cm	Turn Table deg
1	5650.00	60.82	68.20	-7.38	56.09	4.73	Peak	192	353
2	5700.00	72.23	105.20	-32.97	67.44	4.79	Peak	192	353
3	5720.00	81.56	110.80	-29.24	76.74	4.82	Peak	192	353
4	5725.00	86.74	122.20	-35.46	81.92	4.82	Peak	192	353
5	5925.00	60.38	68.20	-7.82	55.30	5.08	Peak	192	353
6	11650.00	44.76	54.00	-9.24	31.02	13.74	Average	175	43
7	11650.00	57.73	74.00	-16.27	43.99	13.74	Peak	175	43
8	17235.00	61.50	68.20	-6.70	43.47	18.03	Peak	100	354

Note 1: Emission Level (dBuV/m) = SA Reading (dBuV/m) + Factor* (dB)

*Factor includes antenna factor , cable loss and amplifier gain

Note 2: Margin (dB) = Emission level (dBuV/m) – Limit (dBuV/m).

Modulation	11a	Test Freq. (MHz)	5745
Polarization	Vertical		

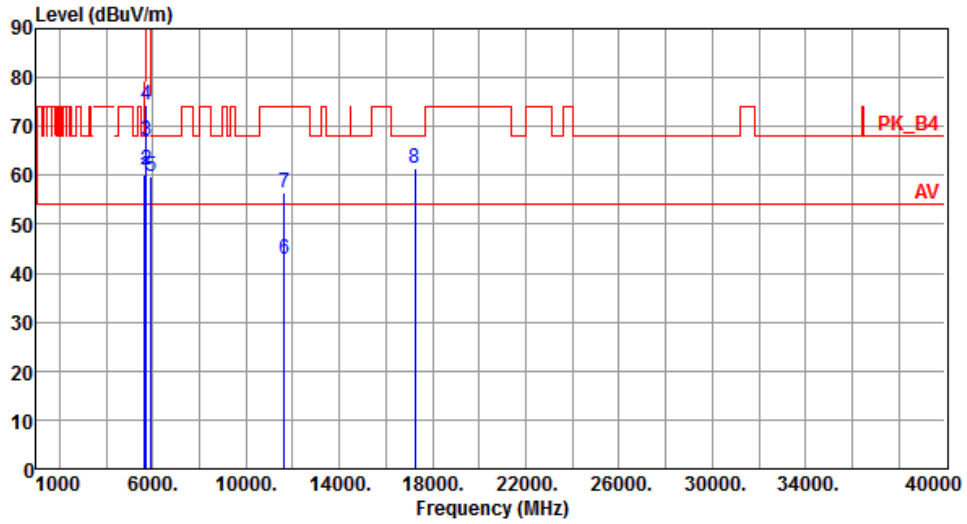

	Freq. MHz	Emission level dBuV/m	Limit dBuV/m	Margin dB	SA reading dBuV	Factor dB	Remark	ANT High cm	Turn Table deg
1	5650.00	59.96	68.20	-8.24	55.23	4.73	Peak	100	27
2	5700.00	61.10	105.20	-44.10	56.31	4.79	Peak	100	27
3	5720.00	67.07	110.80	-43.73	62.25	4.82	Peak	100	27
4	5725.00	74.39	122.20	-47.81	69.57	4.82	Peak	100	27
5	5925.00	59.83	68.20	-8.37	54.75	5.08	Peak	100	27
6	11650.00	42.72	54.00	-11.28	28.98	13.74	Average	100	247
7	11650.00	56.43	74.00	-17.57	42.69	13.74	Peak	100	247
8	17235.00	61.60	68.20	-6.60	43.57	18.03	Peak	100	247

Note 1: Emission Level (dBuV/m) = SA Reading (dBuV/m) + Factor* (dB)

*Factor includes antenna factor , cable loss and amplifier gain

Note 2: Margin (dB) = Emission level (dBuV/m) – Limit (dBuV/m).

Modulation	11a	Test Freq. (MHz)	5785
Polarization	Horizontal		

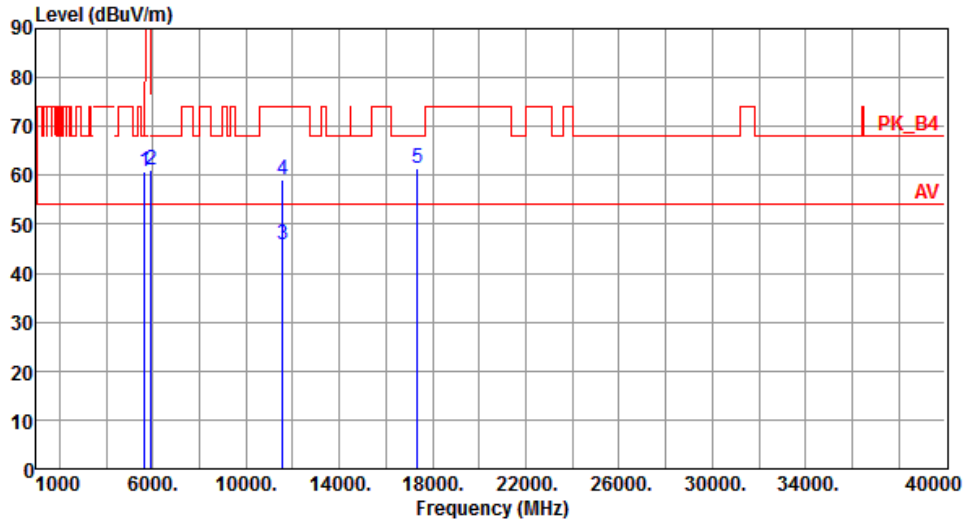

	Freq. MHz	Emission level dBuV/m	Limit dBuV/m	Margin dB	SA reading dBuV	Factor dB	Remark	ANT High cm	Turn Table deg
1	5650.00	60.94	68.20	-7.26	56.21	4.73	Peak	201	341
2	5925.00	61.19	68.20	-7.01	56.11	5.08	Peak	201	341
3	11570.00	45.74	54.00	-8.26	31.91	13.83	Average	163	42
4	11570.00	59.12	74.00	-14.88	45.29	13.83	Peak	163	42
5	17355.00	61.50	68.20	-6.70	43.14	18.36	Peak	10	345

Note 1: Emission Level (dBuV/m) = SA Reading (dBuV/m) + Factor* (dB)

*Factor includes antenna factor , cable loss and amplifier gain

Note 2: Margin (dB) = Emission level (dBuV/m) – Limit (dBuV/m).

Modulation	11a	Test Freq. (MHz)	5785
Polarization	Vertical		

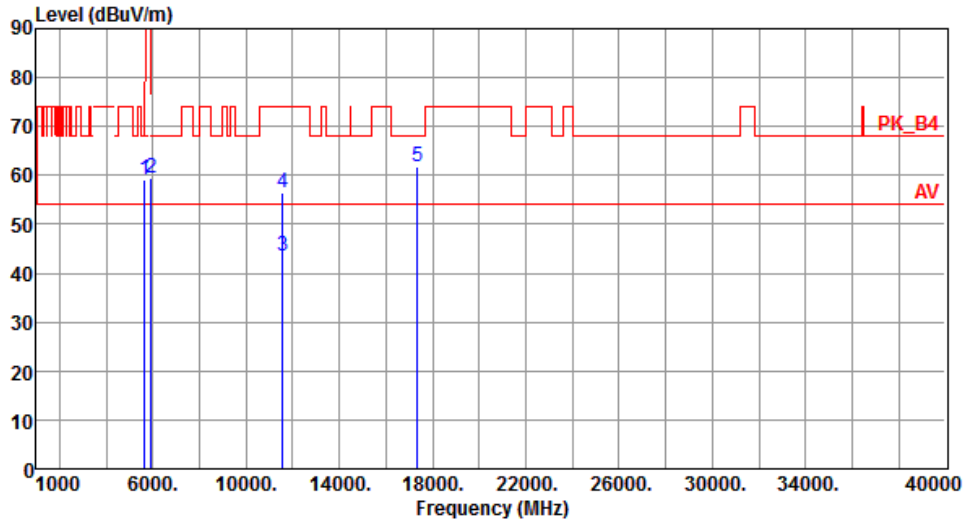

	Freq. MHz	Emission level dBuV/m	Limit dBuV/m	Margin dB	SA reading dBuV	Factor dB	Remark	ANT High cm	Turn Table deg
1	5650.00	59.26	68.20	-8.94	54.53	4.73	Peak	100	27
2	5925.00	59.49	68.20	-8.71	54.41	5.08	Peak	100	27
3	11570.00	43.37	54.00	-10.63	29.54	13.83	Average	100	242
4	11570.00	56.40	74.00	-17.60	42.57	13.83	Peak	100	242
5	17355.00	61.93	68.20	-6.27	43.57	18.36	Peak	100	29

Note 1: Emission Level (dBuV/m) = SA Reading (dBuV/m) + Factor* (dB)

*Factor includes antenna factor , cable loss and amplifier gain

Note 2: Margin (dB) = Emission level (dBuV/m) – Limit (dBuV/m).

Modulation	11a	Test Freq. (MHz)	5825
Polarization	Horizontal		

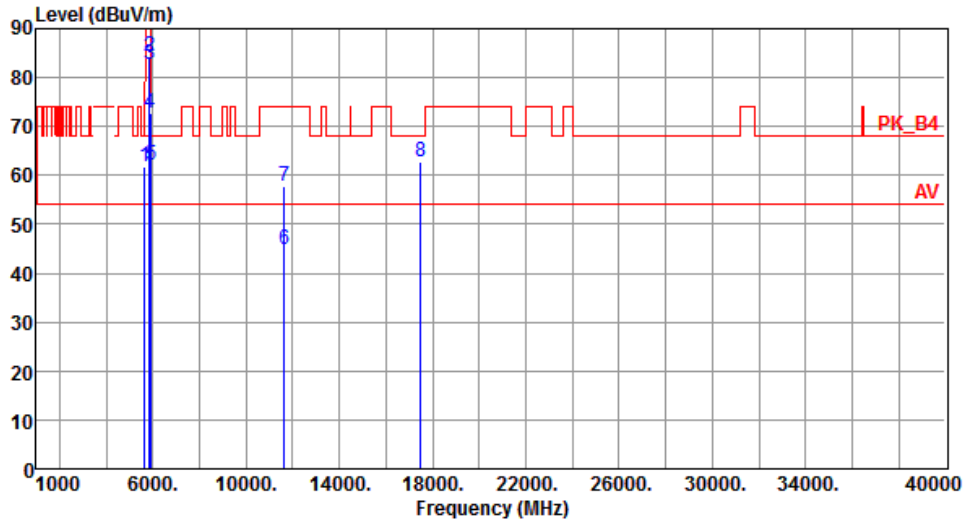

	Freq. MHz	Emission level dBuV/m	Limit dBuV/m	Margin dB	SA reading dBuV	Factor dB	Remark	ANT High cm	Turn Table deg
1	5650.00	61.64	68.20	-6.56	56.91	4.73	Peak	184	350
2	5850.00	84.34	122.20	-37.86	79.35	4.99	Peak	184	350
3	5855.00	82.85	110.80	-27.95	77.85	5.00	Peak	184	350
4	5875.00	72.85	105.20	-32.35	67.83	5.02	Peak	184	350
5	5925.00	62.15	68.20	-6.05	57.07	5.08	Peak	184	350
6	11650.00	44.94	54.00	-9.06	31.20	13.74	Average	147	43
7	11650.00	57.90	74.00	-16.10	44.16	13.74	Peak	147	43
8	17475.00	62.69	68.20	-5.51	44.00	18.69	Peak	100	354

Note 1: Emission Level (dBuV/m) = SA Reading (dBuV/m) + Factor* (dB)

*Factor includes antenna factor , cable loss and amplifier gain

Note 2: Margin (dB) = Emission level (dBuV/m) – Limit (dBuV/m).

Modulation	11a	Test Freq. (MHz)	5825
Polarization	Vertical		

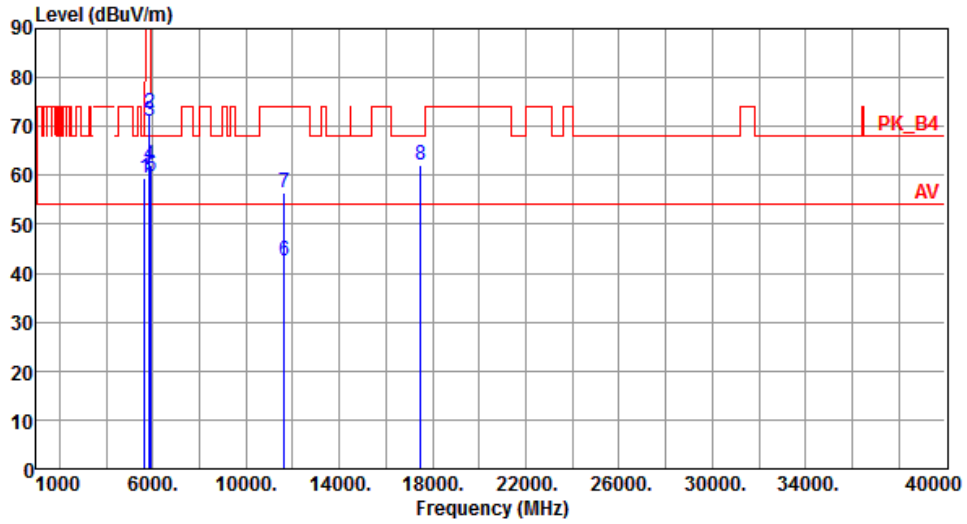

	Freq. MHz	Emission level dBuV/m	Limit dBuV/m	Margin dB	SA reading dBuV	Factor dB	Remark	ANT High cm	Turn Table deg
1	5650.00	59.55	68.20	-8.65	54.82	4.73	Peak	100	21
2	5850.00	72.89	122.20	-49.31	67.90	4.99	Peak	100	21
3	5855.00	71.13	110.80	-39.67	66.13	5.00	Peak	100	21
4	5875.00	62.17	105.20	-43.03	57.15	5.02	Peak	100	21
5	5925.00	59.76	68.20	-8.44	54.68	5.08	Peak	100	21
6	11650.00	42.43	54.00	-11.57	28.69	13.74	Average	100	238
7	11650.00	56.49	74.00	-17.51	42.75	13.74	Peak	100	238
8	17475.00	61.94	68.20	-6.26	43.25	18.69	Peak	100	35

Note 1: Emission Level (dBuV/m) = SA Reading (dBuV/m) + Factor* (dB)

*Factor includes antenna factor , cable loss and amplifier gain

Note 2: Margin (dB) = Emission level (dBuV/m) – Limit (dBuV/m).

3.5.11 Transmitter Radiated Unwanted Emissions (Above 1GHz) for VHT20

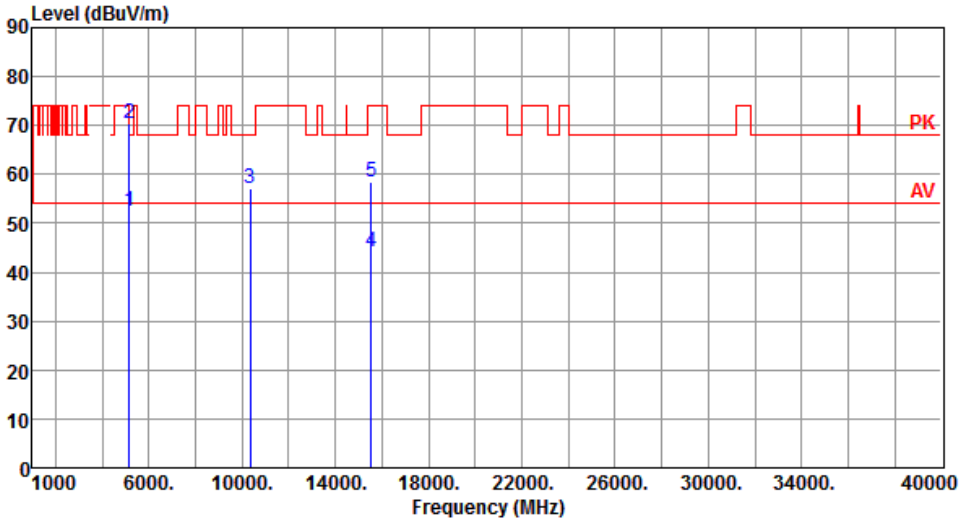
Modulation	VHT20	Test Freq. (MHz)	5180																																																																
Polarization	Horizontal																																																																		
																																																																			
	<table border="1"> <thead> <tr> <th>Freq.</th> <th>Emission level</th> <th>Limit</th> <th>Margin</th> <th>SA reading</th> <th>Factor</th> <th>Remark</th> <th>ANT High</th> <th>Turn Table</th> </tr> <tr> <th>MHz</th> <th>dBuV/m</th> <th>dBuV/m</th> <th>dB</th> <th>dBuV</th> <th>dB</th> <th></th> <th>cm</th> <th>deg</th> </tr> </thead> <tbody> <tr> <td>1</td> <td>52.34</td> <td>54.00</td> <td>-1.66</td> <td>48.10</td> <td>4.24</td> <td>Average</td> <td>218</td> <td>337</td> </tr> <tr> <td>2</td> <td>70.43</td> <td>74.00</td> <td>-3.57</td> <td>66.19</td> <td>4.24</td> <td>Peak</td> <td>218</td> <td>337</td> </tr> <tr> <td>3</td> <td>57.16</td> <td>68.20</td> <td>-11.04</td> <td>43.47</td> <td>13.69</td> <td>Peak</td> <td>157</td> <td>48</td> </tr> <tr> <td>4</td> <td>44.20</td> <td>54.00</td> <td>-9.80</td> <td>29.51</td> <td>14.69</td> <td>Average</td> <td>100</td> <td>348</td> </tr> <tr> <td>5</td> <td>58.56</td> <td>74.00</td> <td>-15.44</td> <td>43.87</td> <td>14.69</td> <td>Peak</td> <td>100</td> <td>348</td> </tr> </tbody> </table>	Freq.	Emission level	Limit	Margin	SA reading	Factor	Remark	ANT High	Turn Table	MHz	dBuV/m	dBuV/m	dB	dBuV	dB		cm	deg	1	52.34	54.00	-1.66	48.10	4.24	Average	218	337	2	70.43	74.00	-3.57	66.19	4.24	Peak	218	337	3	57.16	68.20	-11.04	43.47	13.69	Peak	157	48	4	44.20	54.00	-9.80	29.51	14.69	Average	100	348	5	58.56	74.00	-15.44	43.87	14.69	Peak	100	348			
Freq.	Emission level	Limit	Margin	SA reading	Factor	Remark	ANT High	Turn Table																																																											
MHz	dBuV/m	dBuV/m	dB	dBuV	dB		cm	deg																																																											
1	52.34	54.00	-1.66	48.10	4.24	Average	218	337																																																											
2	70.43	74.00	-3.57	66.19	4.24	Peak	218	337																																																											
3	57.16	68.20	-11.04	43.47	13.69	Peak	157	48																																																											
4	44.20	54.00	-9.80	29.51	14.69	Average	100	348																																																											
5	58.56	74.00	-15.44	43.87	14.69	Peak	100	348																																																											
<p>Note 1: Emission Level (dBuV/m) = SA Reading (dBuV/m) + Factor* (dB) *Factor includes antenna factor , cable loss and amplifier gain Note 2: Margin (dB) = Emission level (dBuV/m) – Limit (dBuV/m).</p>																																																																			

Modulation	VHT20	Test Freq. (MHz)	5180
Polarization	Vertical		

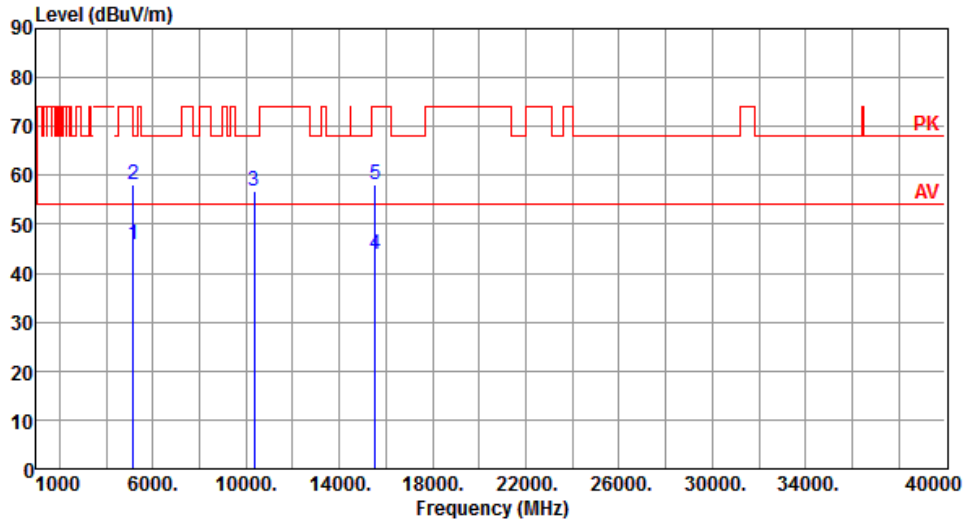

	Freq. MHz	Emission level dBuV/m	Limit dBuV/m	Margin dB	SA reading dBuV	Factor dB	Remark	ANT High cm	Turn Table deg
1	5150.00	45.83	54.00	-8.17	41.59	4.24	Average	100	33
2	5150.00	57.99	74.00	-16.01	53.75	4.24	Peak	100	33
3	10360.00	56.93	68.20	-11.27	43.24	13.69	Peak	124	247
4	15540.00	43.81	54.00	-10.19	29.12	14.69	Average	100	35
5	15540.00	58.09	74.00	-15.91	43.40	14.69	Peak	100	35

Note 1: Emission Level (dBuV/m) = SA Reading (dBuV/m) + Factor* (dB)

*Factor includes antenna factor , cable loss and amplifier gain

Note 2: Margin (dB) = Emission level (dBuV/m) – Limit (dBuV/m).

Modulation	VHT20	Test Freq. (MHz)	5200
Polarization	Horizontal		

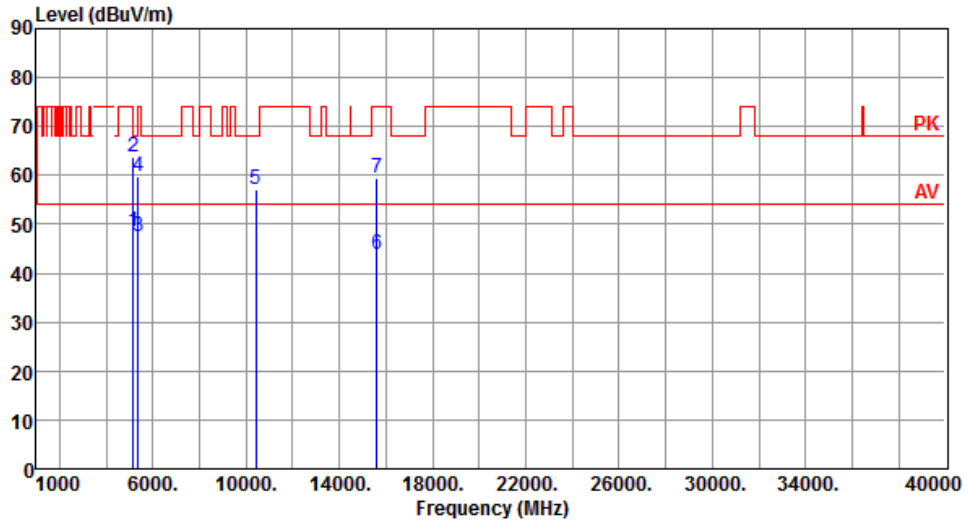

	Freq. MHz	Emission level dBuV/m	Limit dBuV/m	Margin dB	SA reading dBuV	Factor dB	Remark	ANT High cm	Turn Table deg
1	5150.00	48.34	54.00	-5.66	44.10	4.24	Average	222	339
2	5150.00	63.91	74.00	-10.09	59.67	4.24	Peak	222	339
3	5350.00	47.63	54.00	-6.37	43.20	4.43	Average	222	339
4	5350.00	59.83	74.00	-14.17	55.40	4.43	Peak	222	339
5	10400.00	57.28	68.20	-10.92	43.57	13.71	Peak	147	37
6	15600.00	43.79	54.00	-10.21	29.14	14.65	Average	100	348
7	15600.00	59.45	74.00	-14.55	44.80	14.65	Peak	100	348

Note 1: Emission Level (dBuV/m) = SA Reading (dBuV/m) + Factor* (dB)

*Factor includes antenna factor , cable loss and amplifier gain

Note 2: Margin (dB) = Emission level (dBuV/m) – Limit (dBuV/m).

Modulation	VHT20	Test Freq. (MHz)	5200
Polarization	Vertical		

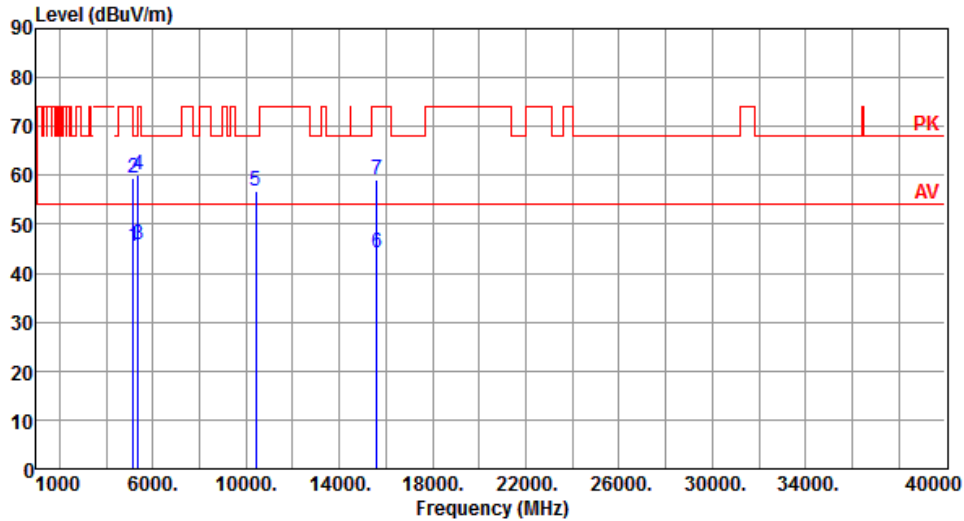

	Freq. MHz	Emission level dBuV/m	Limit dBuV/m	Margin dB	SA reading dBuV	Factor dB	Remark	ANT High cm	Turn Table deg
1	5150.00	45.49	54.00	-8.51	41.25	4.24	Average	100	32
2	5150.00	59.36	74.00	-14.64	55.12	4.24	Peak	100	32
3	5350.00	45.97	54.00	-8.03	41.54	4.43	Average	100	32
4	5350.00	60.06	74.00	-13.94	55.63	4.43	Peak	100	32
5	10400.00	56.85	68.20	-11.35	43.14	13.71	Peak	124	248
6	15600.00	44.12	54.00	-9.88	29.47	14.65	Average	100	34
7	15600.00	59.19	74.00	-14.81	44.54	14.65	Peak	100	34

Note 1: Emission Level (dBuV/m) = SA Reading (dBuV/m) + Factor* (dB)

*Factor includes antenna factor , cable loss and amplifier gain

Note 2: Margin (dB) = Emission level (dBuV/m) – Limit (dBuV/m).

Modulation	VHT20	Test Freq. (MHz)	5240
Polarization	Horizontal		

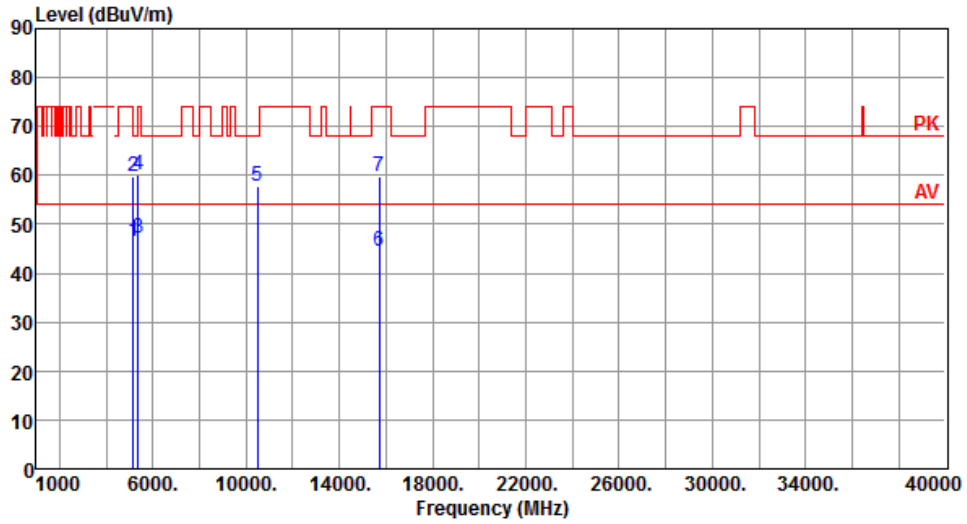

	Freq. MHz	Emission level dBuV/m	Limit dBuV/m	Margin dB	SA reading dBuV	Factor dB	Remark	ANT High cm	Turn Table deg
1	5150.00	46.48	54.00	-7.52	42.24	4.24	Average	200	320
2	5150.00	59.77	74.00	-14.23	55.53	4.24	Peak	200	320
3	5350.00	47.26	54.00	-6.74	42.83	4.43	Average	200	320
4	5350.00	60.10	74.00	-13.90	55.67	4.43	Peak	200	320
5	10480.00	57.63	68.20	-10.57	43.89	13.74	Peak	154	39
6	15720.00	44.45	54.00	-9.55	29.87	14.58	Average	100	345
7	15720.00	59.64	74.00	-14.36	45.06	14.58	Peak	100	345

Note 1: Emission Level (dBuV/m) = SA Reading (dBuV/m) + Factor* (dB)

*Factor includes antenna factor , cable loss and amplifier gain

Note 2: Margin (dB) = Emission level (dBuV/m) – Limit (dBuV/m).

Modulation	VHT20	Test Freq. (MHz)	5240
Polarization	Vertical		

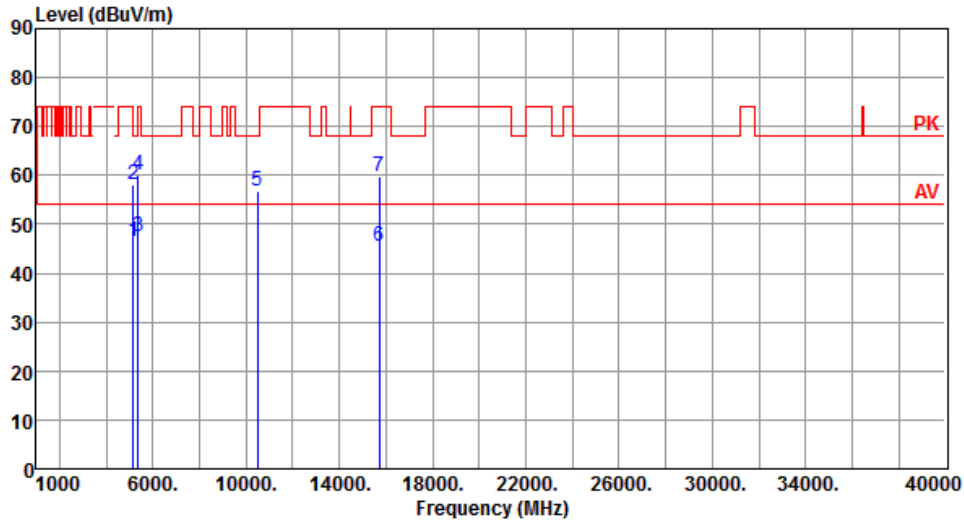

	Freq. MHz	Emission level dBuV/m	Limit dBuV/m	Margin dB	SA reading dBuV	Factor dB	Remark	ANT High cm	Turn Table deg
1	5150.00	46.51	54.00	-7.49	42.27	4.24	Average	100	28
2	5150.00	58.03	74.00	-15.97	53.79	4.24	Peak	100	28
3	5350.00	47.63	54.00	-6.37	43.20	4.43	Average	100	28
4	5350.00	60.06	74.00	-13.94	55.63	4.43	Peak	100	28
5	10480.00	56.79	68.20	-11.41	43.05	13.74	Peak	131	250
6	15720.00	45.34	54.00	-8.66	30.76	14.58	Average	100	26
7	15720.00	59.87	74.00	-14.13	45.29	14.58	Peak	100	26

Note 1: Emission Level (dBuV/m) = SA Reading (dBuV/m) + Factor* (dB)

*Factor includes antenna factor , cable loss and amplifier gain

Note 2: Margin (dB) = Emission level (dBuV/m) – Limit (dBuV/m).

Modulation	VHT20	Test Freq. (MHz)	5260
Polarization	Horizontal		

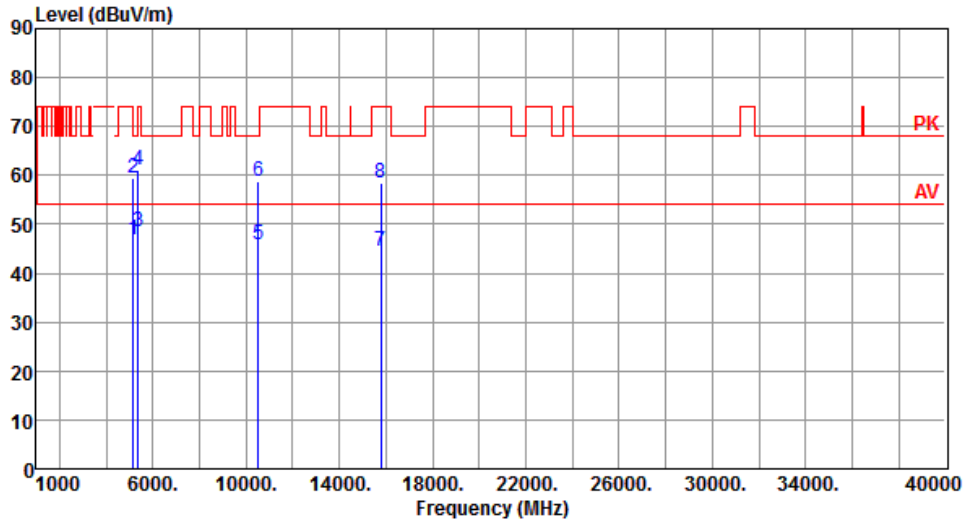

	Freq. MHz	Emission level dBuV/m	Limit dBuV/m	Margin dB	SA reading dBuV	Factor dB	Remark	ANT High cm	Turn Table deg
1	5150.00	46.71	54.00	-7.29	42.47	4.24	Average	225	342
2	5150.00	59.38	74.00	-14.62	55.14	4.24	Peak	225	342
3	5350.00	48.63	54.00	-5.37	44.20	4.43	Average	225	342
4	5350.00	61.03	74.00	-12.97	56.60	4.43	Peak	225	342
5	10520.00	45.91	54.00	-8.09	32.14	13.77	Average	169	34
6	10520.00	58.75	68.20	-9.45	44.98	13.77	Peak	169	34
7	15780.00	44.35	54.00	-9.65	29.80	14.55	Average	100	357
8	15780.00	58.43	74.00	-15.57	43.88	14.55	Peak	100	357

Note 1: Emission Level (dBuV/m) = SA Reading (dBuV/m) + Factor* (dB)

*Factor includes antenna factor , cable loss and amplifier gain

Note 2: Margin (dB) = Emission level (dBuV/m) – Limit (dBuV/m).

Modulation	VHT20	Test Freq. (MHz)	5260
Polarization	Vertical		

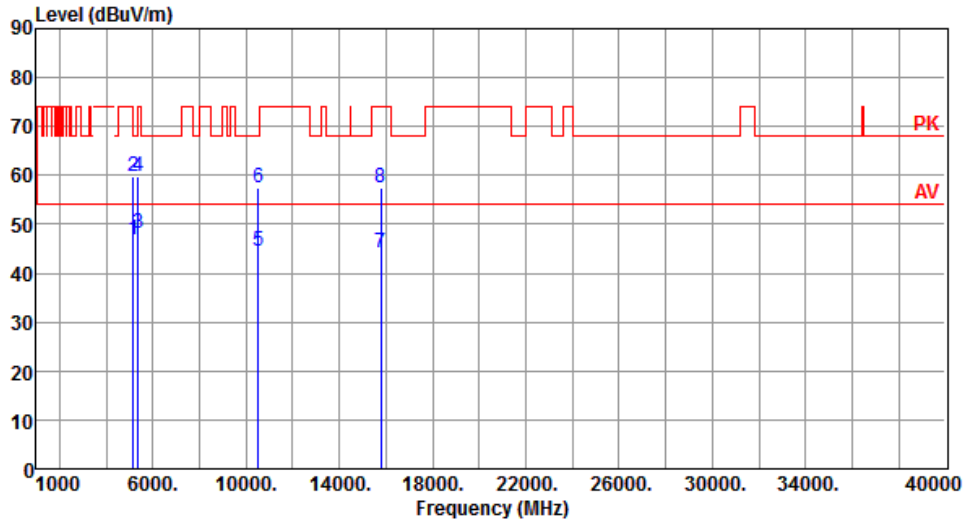

	Freq. MHz	Emission level dBuV/m	Limit dBuV/m	Margin dB	SA reading dBuV	Factor dB	Remark	ANT High cm	Turn Table deg
1	5150.00	46.84	54.00	-7.16	42.60	4.24	Average	100	29
2	5150.00	59.91	74.00	-14.09	55.67	4.24	Peak	100	29
3	5350.00	48.30	54.00	-5.70	43.87	4.43	Average	100	29
4	5350.00	59.76	74.00	-14.24	55.33	4.43	Peak	100	29
5	10520.00	44.62	54.00	-9.38	30.85	13.77	Average	157	245
6	10520.00	57.57	68.20	-10.63	43.80	13.77	Peak	157	245
7	15780.00	44.19	54.00	-9.81	29.64	14.55	Average	100	24
8	15780.00	57.44	74.00	-16.56	42.89	14.55	Peak	100	24

Note 1: Emission Level (dBuV/m) = SA Reading (dBuV/m) + Factor* (dB)

*Factor includes antenna factor , cable loss and amplifier gain

Note 2: Margin (dB) = Emission level (dBuV/m) – Limit (dBuV/m).

Modulation	VHT20	Test Freq. (MHz)	5300
Polarization	Horizontal		

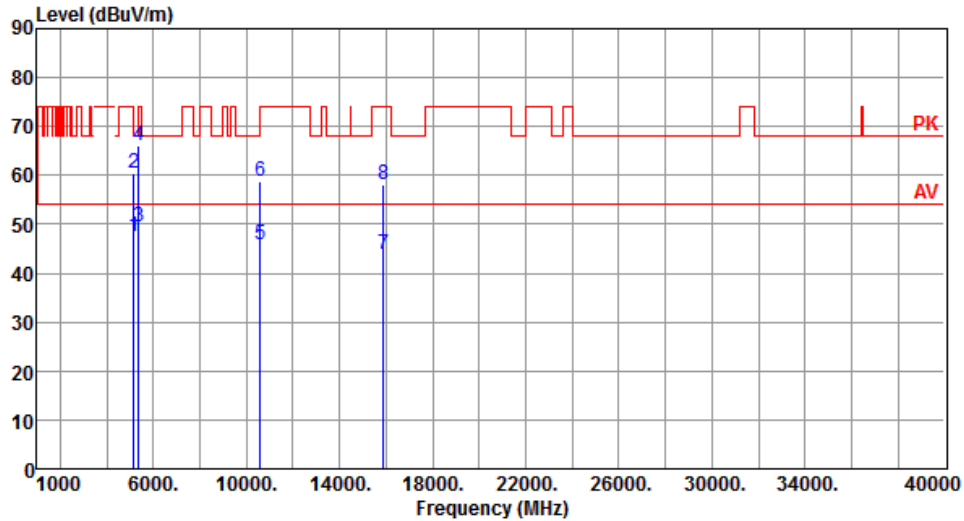

	Freq. MHz	Emission level dBuV/m	Limit dBuV/m	Margin dB	SA reading dBuV	Factor dB	Remark	ANT High cm	Turn Table deg
1	5150.00	47.35	54.00	-6.65	43.11	4.24	Average	200	331
2	5150.00	60.34	74.00	-13.66	56.10	4.24	Peak	200	331
3	5350.00	49.58	54.00	-4.42	45.15	4.43	Average	200	331
4	5350.00	66.00	74.00	-8.00	61.57	4.43	Peak	200	331
5	10600.00	45.99	54.00	-8.01	32.12	13.87	Average	185	33
6	10600.00	58.94	74.00	-15.06	45.07	13.87	Peak	185	33
7	15900.00	43.99	54.00	-10.01	29.51	14.48	Average	100	335
8	15900.00	57.98	74.00	-16.02	43.50	14.48	Peak	100	335

Note 1: Emission Level (dBuV/m) = SA Reading (dBuV/m) + Factor* (dB)

*Factor includes antenna factor , cable loss and amplifier gain

Note 2: Margin (dB) = Emission level (dBuV/m) – Limit (dBuV/m).

Modulation	VHT20	Test Freq. (MHz)	5300
Polarization	Vertical		

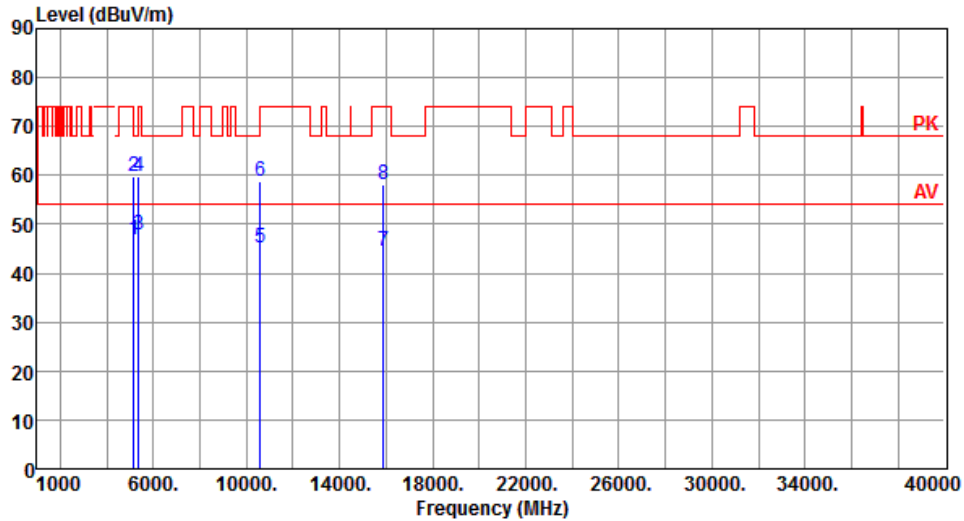

	Freq. MHz	Emission level dBuV/m	Limit dBuV/m	Margin dB	SA reading dBuV	Factor dB	Remark	ANT High cm	Turn Table deg
1	5150.00	46.92	54.00	-7.08	42.68	4.24	Average	111	29
2	5150.00	59.65	74.00	-14.35	55.41	4.24	Peak	111	29
3	5350.00	47.74	54.00	-6.26	43.31	4.43	Average	111	29
4	5350.00	59.81	74.00	-14.19	55.38	4.43	Peak	111	29
5	10600.00	45.27	54.00	-8.73	31.40	13.87	Average	148	241
6	10600.00	58.67	74.00	-15.33	44.80	13.87	Peak	148	241
7	15900.00	44.35	54.00	-9.65	29.87	14.48	Average	100	31
8	15900.00	58.06	74.00	-15.94	43.58	14.48	Peak	100	31

Note 1: Emission Level (dBuV/m) = SA Reading (dBuV/m) + Factor* (dB)

*Factor includes antenna factor , cable loss and amplifier gain

Note 2: Margin (dB) = Emission level (dBuV/m) – Limit (dBuV/m).

Modulation	VHT20	Test Freq. (MHz)	5320
Polarization	Horizontal		

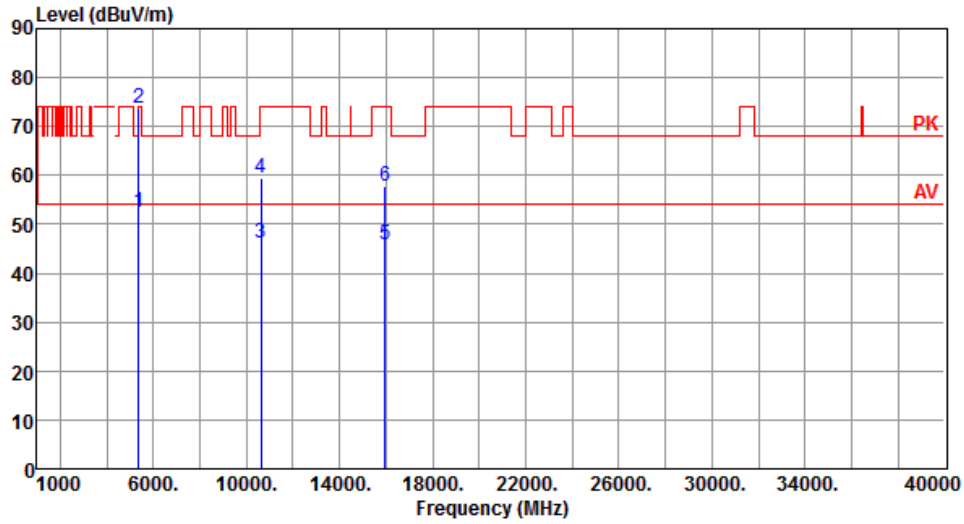

	Freq. MHz	Emission level dBuV/m	Limit dBuV/m	Margin dB	SA reading dBuV	Factor dB	Remark	ANT High cm	Turn Table deg
1	5350.00	52.42	54.00	-1.58	47.99	4.43	Average	197	333
2	5350.00	73.78	74.00	-0.22	69.35	4.43	Peak	197	333
3	10640.00	46.32	54.00	-7.68	32.40	13.92	Average	177	54
4	10640.00	59.44	74.00	-14.56	45.52	13.92	Peak	177	54
5	15960.00	45.67	54.00	-8.33	31.23	14.44	Average	100	345
6	15960.00	57.94	74.00	-16.06	43.50	14.44	Peak	100	345

Note 1: Emission Level (dBuV/m) = SA Reading (dBuV/m) + Factor* (dB)

*Factor includes antenna factor , cable loss and amplifier gain

Note 2: Margin (dB) = Emission level (dBuV/m) – Limit (dBuV/m).

Modulation	VHT20	Test Freq. (MHz)	5320
Polarization	Vertical		

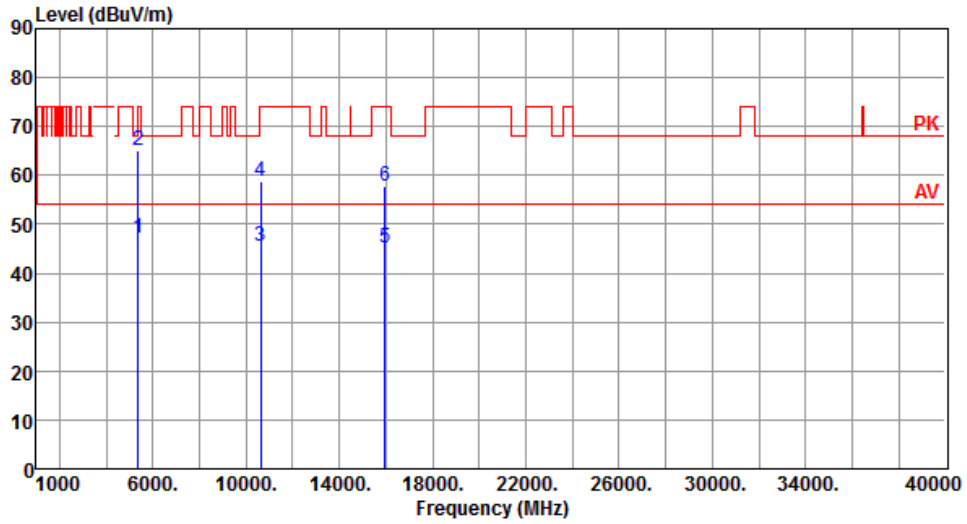

	Freq. MHz	Emission level dBuV/m	Limit dBuV/m	Margin dB	SA reading dBuV	Factor dB	Remark	ANT High cm	Turn Table deg
1	5350.00	47.21	54.00	-6.79	42.78	4.43	Average	100	30
2	5350.00	65.04	74.00	-8.96	60.61	4.43	Peak	100	30
3	10640.00	45.66	54.00	-8.34	31.74	13.92	Average	149	265
4	10640.00	58.93	74.00	-15.07	45.01	13.92	Peak	149	265
5	15960.00	45.31	54.00	-8.69	30.87	14.44	Average	100	33
6	15960.00	57.94	74.00	-16.06	43.50	14.44	Peak	100	33

Note 1: Emission Level (dBuV/m) = SA Reading (dBuV/m) + Factor* (dB)

*Factor includes antenna factor , cable loss and amplifier gain

Note 2: Margin (dB) = Emission level (dBuV/m) – Limit (dBuV/m).

Modulation	VHT20	Test Freq. (MHz)	5500
Polarization	Horizontal		

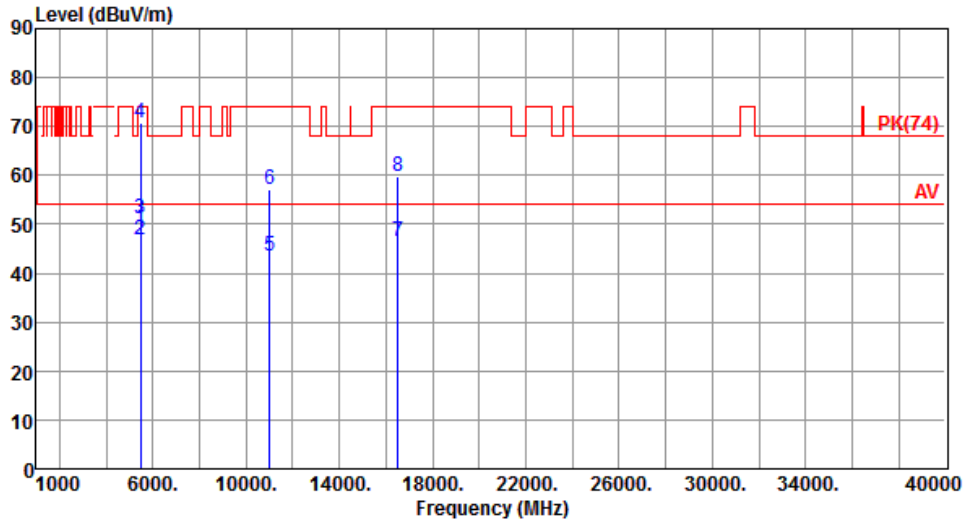

	Freq. MHz	Emission level dBuV/m	Limit dBuV/m	Margin dB	SA reading dBuV	Factor dB	Remark	ANT High cm	Turn Table deg
1	5460.00	49.21	54.00	-4.79	44.70	4.51	Average	200	337
2	5460.00	46.92	74.00	-27.08	42.41	4.51	Peak	200	337
3	5470.00	50.99	54.00	-3.01	46.47	4.52	Average	200	337
4	5470.00	70.79	74.00	-3.21	66.27	4.52	Peak	200	337
5	11000.00	43.46	54.00	-10.54	29.12	14.34	Average	100	34
6	11000.00	57.18	74.00	-16.82	42.84	14.34	Peak	100	34
7	16500.00	46.37	54.00	-7.63	29.89	16.48	Average	100	342
8	16500.00	59.76	74.00	-14.24	43.28	16.48	Peak	100	342

Note 1: Emission Level (dBuV/m) = SA Reading (dBuV/m) + Factor* (dB)
 *Factor includes antenna factor , cable loss and amplifier gain
 Note 2: Margin (dB) = Emission level (dBuV/m) – Limit (dBuV/m).

Modulation	VHT20	Test Freq. (MHz)	5500
Polarization	Vertical		

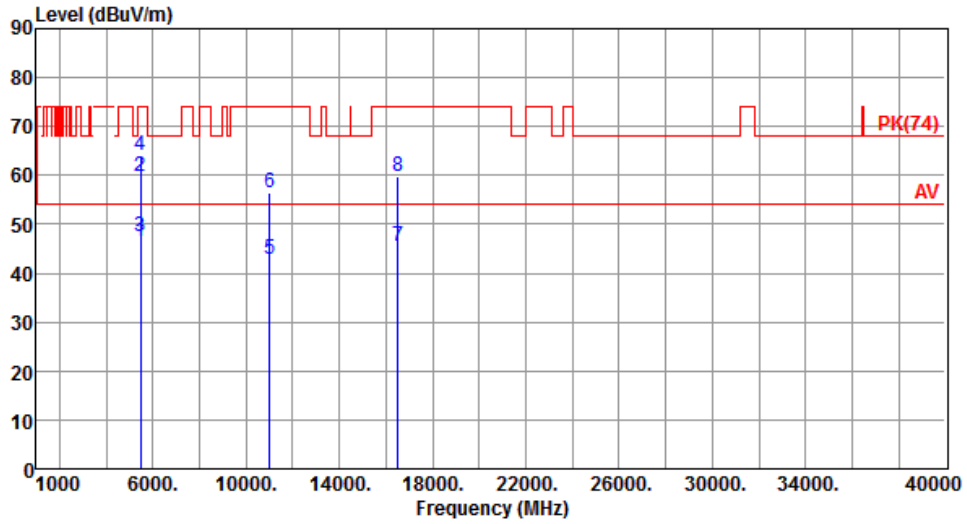

	Freq. MHz	Emission level dBuV/m	Limit dBuV/m	Margin dB	SA reading dBuV	Factor dB	Remark	ANT High cm	Turn Table deg
1	5460.00	46.44	54.00	-7.56	41.93	4.51	Average	100	25
2	5460.00	59.87	74.00	-14.13	55.36	4.51	Peak	100	25
3	5470.00	47.42	54.00	-6.58	42.90	4.52	Average	100	25
4	5470.00	64.23	74.00	-9.77	59.71	4.52	Peak	100	25
5	11000.00	42.91	54.00	-11.09	28.57	14.34	Average	100	245
6	11000.00	56.58	74.00	-17.42	42.24	14.34	Peak	100	245
7	16500.00	45.48	54.00	-8.52	29.00	16.48	Average	100	245
8	16500.00	59.62	74.00	-14.38	43.14	16.48	Peak	100	245

Note 1: Emission Level (dBuV/m) = SA Reading (dBuV/m) + Factor* (dB)

*Factor includes antenna factor , cable loss and amplifier gain

Note 2: Margin (dB) = Emission level (dBuV/m) – Limit (dBuV/m).

Modulation	VHT20	Test Freq. (MHz)	5580
Polarization	Horizontal		

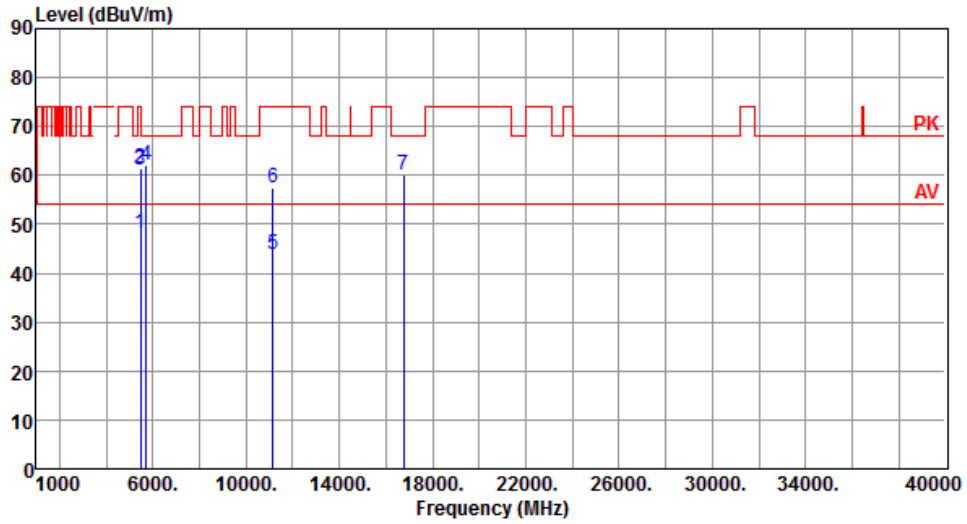

	Freq. MHz	Emission level dBuV/m	Limit dBuV/m	Margin dB	SA reading dBuV	Factor dB	Remark	ANT High cm	Turn Table deg
1	5460.00	48.06	54.00	-5.94	43.55	4.51	Average	192	335
2	5460.00	61.28	74.00	-12.72	56.77	4.51	Peak	192	335
3	5470.00	61.11	68.20	-7.09	56.59	4.52	Peak	192	335
4	5725.00	62.24	68.20	-5.96	57.42	4.82	Peak	192	335
5	11160.00	43.70	54.00	-10.30	29.50	14.20	Average	157	36
6	11160.00	57.44	74.00	-16.56	43.24	14.20	Peak	157	36
7	16740.00	60.06	68.20	-8.14	43.14	16.92	Peak	100	334

Note 1: Emission Level (dBuV/m) = SA Reading (dBuV/m) + Factor* (dB)

*Factor includes antenna factor , cable loss and amplifier gain

Note 2: Margin (dB) = Emission level (dBuV/m) – Limit (dBuV/m).

Modulation	VHT20	Test Freq. (MHz)	5580
Polarization	Vertical		

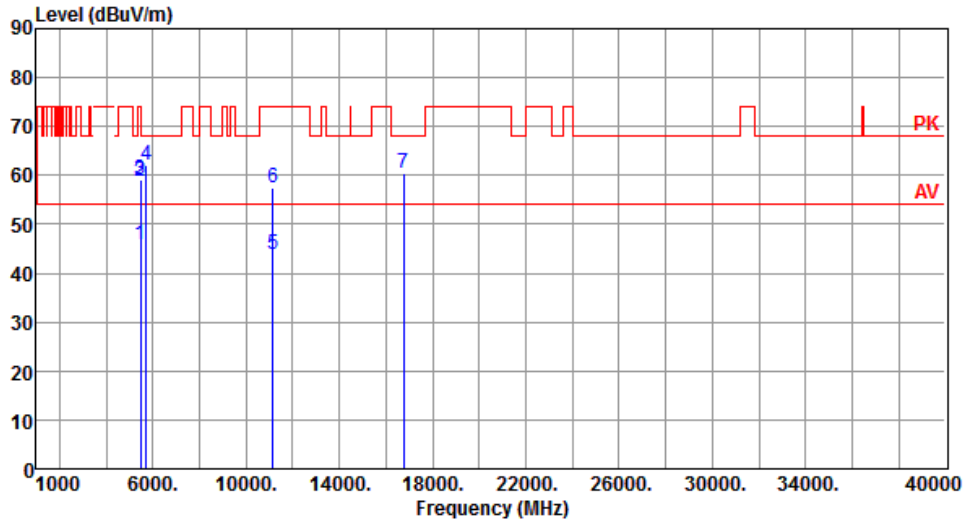

	Freq. MHz	Emission level dBuV/m	Limit dBuV/m	Margin dB	SA reading dBuV	Factor dB	Remark	ANT High cm	Turn Table deg
1	5460.00	45.81	54.00	-8.19	41.30	4.51	Average	100	27
2	5460.00	58.85	74.00	-15.15	54.34	4.51	Peak	100	27
3	5470.00	59.06	68.20	-9.14	54.54	4.52	Peak	100	27
4	5725.00	61.97	68.20	-6.23	57.15	4.82	Peak	100	27
5	11160.00	43.94	54.00	-10.06	29.74	14.20	Average	100	247
6	11160.00	57.57	74.00	-16.43	43.37	14.20	Peak	100	247
7	16740.00	60.46	68.20	-7.74	43.54	16.92	Peak	100	29

Note 1: Emission Level (dBuV/m) = SA Reading (dBuV/m) + Factor* (dB)

*Factor includes antenna factor , cable loss and amplifier gain

Note 2: Margin (dB) = Emission level (dBuV/m) – Limit (dBuV/m).

Modulation	VHT20	Test Freq. (MHz)	5700
Polarization	Horizontal		

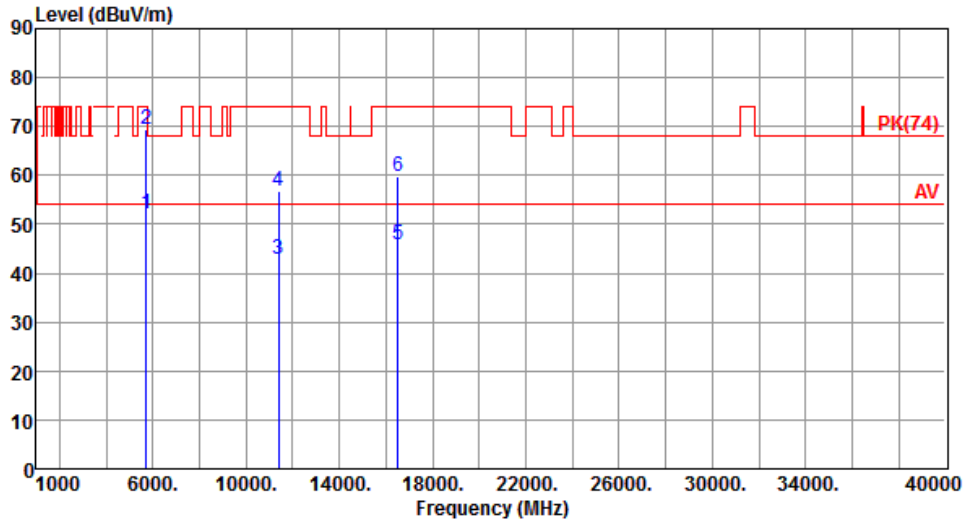

	Freq. MHz	Emission level dBuV/m	Limit dBuV/m	Margin dB	SA reading dBuV	Factor dB	Remark	ANT High cm	Turn Table deg
1	5725.00	52.10	54.00	-1.90	47.28	4.82	Average	201	329
2	5725.00	69.38	74.00	-4.62	64.56	4.82	Peak	201	329
3	11400.00	42.97	54.00	-11.03	28.97	14.00	Average	100	32
4	11400.00	56.66	74.00	-17.34	42.66	14.00	Peak	100	32
5	16500.00	45.95	54.00	-8.05	29.47	16.48	Average	100	331
6	16500.00	59.81	74.00	-14.19	43.33	16.48	Peak	100	331

Note 1: Emission Level (dBuV/m) = SA Reading (dBuV/m) + Factor* (dB)

*Factor includes antenna factor , cable loss and amplifier gain

Note 2: Margin (dB) = Emission level (dBuV/m) – Limit (dBuV/m).

Modulation	VHT20	Test Freq. (MHz)	5700
Polarization	Vertical		

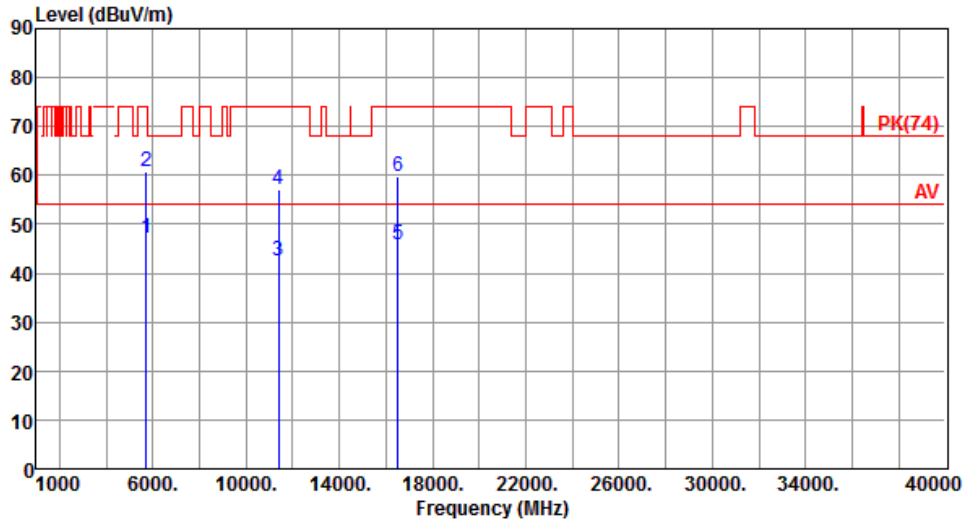

	Freq. MHz	Emission level dBuV/m	Limit dBuV/m	Margin dB	SA reading dBuV	Factor dB	Remark	ANT High cm	Turn Table deg
1	5725.00	47.26	54.00	-6.74	42.44	4.82	Average	100	25
2	5725.00	60.85	74.00	-13.15	56.03	4.82	Peak	100	25
3	11400.00	42.67	54.00	-11.33	28.67	14.00	Average	100	241
4	11400.00	57.25	74.00	-16.75	43.25	14.00	Peak	100	241
5	16500.00	45.82	54.00	-8.18	29.34	16.48	Average	100	29
6	16500.00	59.72	74.00	-14.28	43.24	16.48	Peak	100	29

Note 1: Emission Level (dBuV/m) = SA Reading (dBuV/m) + Factor* (dB)

*Factor includes antenna factor , cable loss and amplifier gain

Note 2: Margin (dB) = Emission level (dBuV/m) – Limit (dBuV/m).

Modulation	VHT20	Test Freq. (MHz)	5720
Polarization	Horizontal		

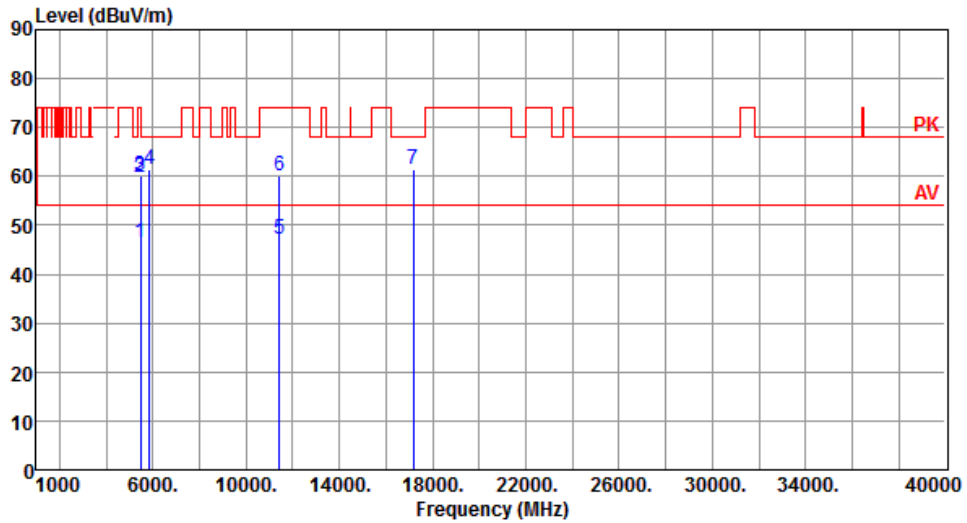

	Freq. MHz	Emission level dBuV/m	Limit dBuV/m	Margin dB	SA reading dBuV	Factor dB	Remark	ANT High cm	Turn Table deg
1	5460.00	46.61	54.00	-7.39	42.10	4.51	Average	188	185
2	5460.00	59.92	74.00	-14.08	55.41	4.51	Peak	188	185
3	5470.00	60.21	68.20	-7.99	55.69	4.52	Peak	188	185
4	5850.00	61.36	68.20	-6.84	56.37	4.99	Peak	188	185
5	11440.00	47.27	54.00	-6.73	33.31	13.96	Average	175	340
6	11440.00	60.27	74.00	-13.73	46.31	13.96	Peak	175	340
7	17160.00	61.39	68.20	-6.81	43.56	17.83	Peak	100	195

Note 1: Emission Level (dBuV/m) = SA Reading (dBuV/m) + Factor* (dB)

*Factor includes antenna factor , cable loss and amplifier gain

Note 2: Margin (dB) = Emission level (dBuV/m) – Limit (dBuV/m).

Modulation	VHT20	Test Freq. (MHz)	5720
Polarization	Vertical		

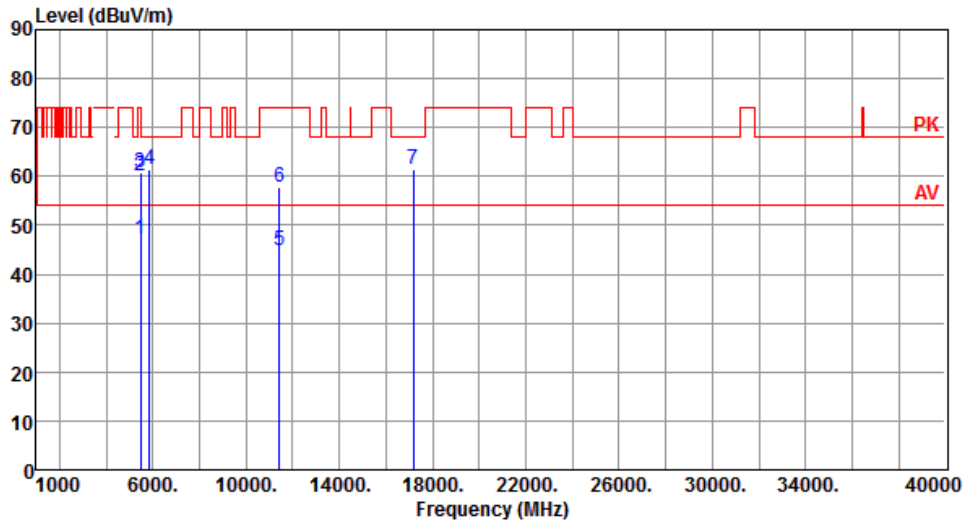

	Freq. MHz	Emission level dBuV/m	Limit dBuV/m	Margin dB	SA reading dBuV	Factor dB	Remark	ANT High cm	Turn Table deg
1	5460.00	47.15	54.00	-6.85	42.64	4.51	Average	205	262
2	5460.00	60.19	74.00	-13.81	55.68	4.51	Peak	205	262
3	5470.00	60.62	68.20	-7.58	56.10	4.52	Peak	205	262
4	5850.00	61.39	68.20	-6.81	56.40	4.99	Peak	205	262
5	11440.00	44.85	54.00	-9.15	30.89	13.96	Average	265	176
6	11440.00	57.63	74.00	-16.37	43.67	13.96	Peak	265	176
7	17160.00	61.33	68.20	-6.87	43.50	17.83	Peak	100	268

Note 1: Emission Level (dBuV/m) = SA Reading (dBuV/m) + Factor* (dB)

*Factor includes antenna factor , cable loss and amplifier gain

Note 2: Margin (dB) = Emission level (dBuV/m) – Limit (dBuV/m).

Modulation	VHT20	Test Freq. (MHz)	5745
Polarization	Horizontal		

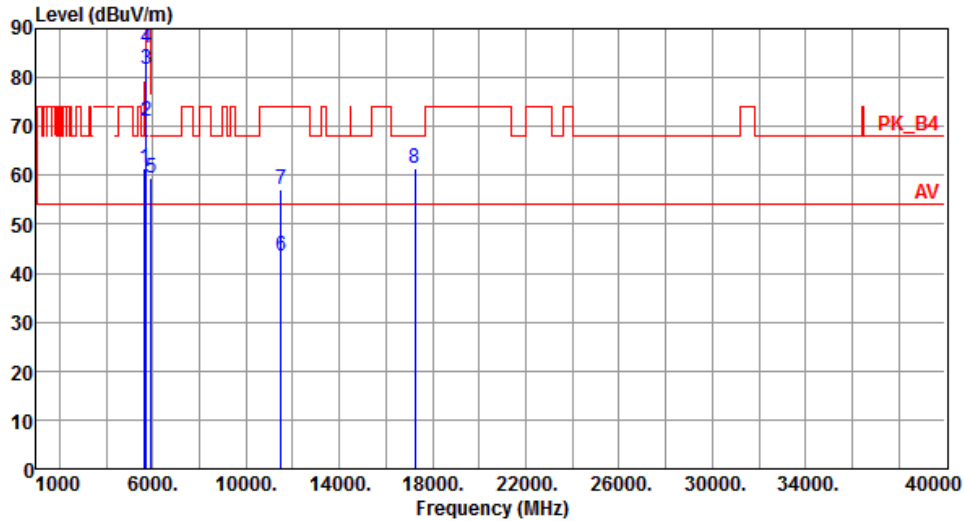

	Freq. MHz	Emission level dBuV/m	Limit dBuV/m	Margin dB	SA reading dBuV	Factor dB	Remark	ANT High cm	Turn Table deg
1	5650.00	61.36	68.20	-6.84	56.63	4.73	Peak	208	342
2	5700.00	70.91	105.20	-34.29	66.12	4.79	Peak	208	342
3	5720.00	81.62	110.80	-29.18	76.80	4.82	Peak	208	342
4	5725.00	86.00	122.20	-36.20	81.18	4.82	Peak	208	342
5	5925.00	59.43	68.20	-8.77	54.35	5.08	Peak	208	342
6	11490.00	43.59	54.00	-10.41	29.67	13.92	Average	100	34
7	11490.00	57.13	74.00	-16.87	43.21	13.92	Peak	100	34
8	17235.00	61.60	68.20	-6.60	43.57	18.03	Peak	100	348

Note 1: Emission Level (dBuV/m) = SA Reading (dBuV/m) + Factor* (dB)

*Factor includes antenna factor , cable loss and amplifier gain

Note 2: Margin (dB) = Emission level (dBuV/m) – Limit (dBuV/m).

Modulation	VHT20	Test Freq. (MHz)	5745
Polarization	Vertical		

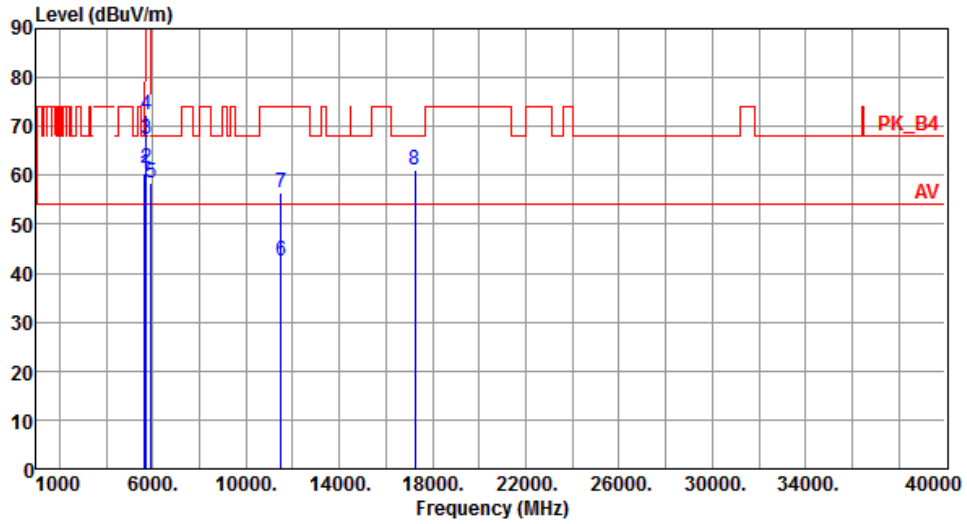

	Freq. MHz	Emission level dBuV/m	Limit dBuV/m	Margin dB	SA reading dBuV	Factor dB	Remark	ANT High cm	Turn Table deg
1	5650.00	60.49	68.20	-7.71	55.76	4.73	Peak	100	26
2	5700.00	61.28	105.20	-43.92	56.49	4.79	Peak	100	26
3	5720.00	67.37	110.80	-43.43	62.55	4.82	Peak	100	26
4	5725.00	72.50	122.20	-49.70	67.68	4.82	Peak	100	26
5	5925.00	58.29	68.20	-9.91	53.21	5.08	Peak	100	26
6	11490.00	42.59	54.00	-11.41	28.67	13.92	Average	100	242
7	11490.00	56.52	74.00	-17.48	42.60	13.92	Peak	100	242
8	17235.00	61.24	68.20	-6.96	43.21	18.03	Peak	100	31

Note 1: Emission Level (dBuV/m) = SA Reading (dBuV/m) + Factor* (dB)

*Factor includes antenna factor , cable loss and amplifier gain

Note 2: Margin (dB) = Emission level (dBuV/m) – Limit (dBuV/m).

Modulation	VHT20	Test Freq. (MHz)	5785
Polarization	Horizontal		

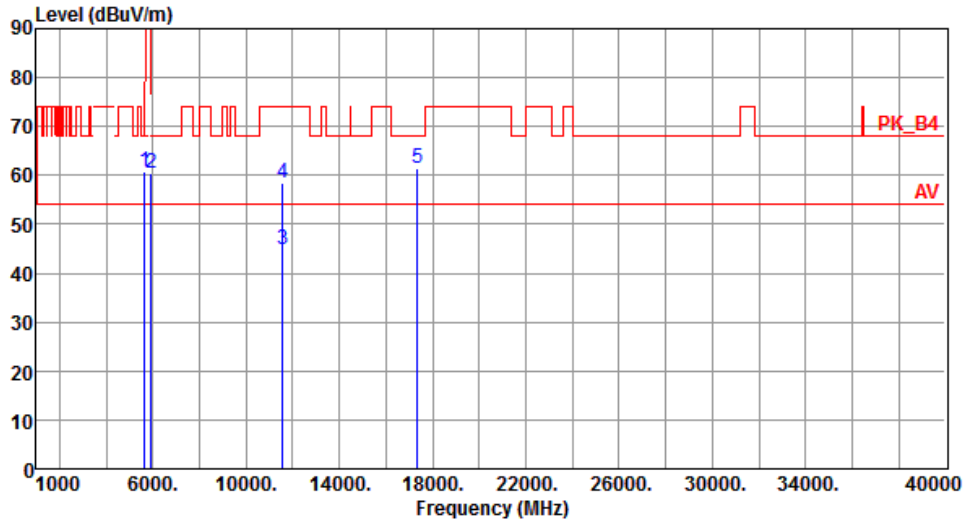

	Freq. MHz	Emission level dBuV/m	Limit dBuV/m	Margin dB	SA reading dBuV	Factor dB	Remark	ANT High cm	Turn Table deg
1	5650.00	60.62	68.20	-7.58	55.89	4.73	Peak	183	349
2	5925.00	60.33	68.20	-7.87	55.25	5.08	Peak	183	349
3	11570.00	44.80	54.00	-9.20	30.97	13.83	Average	162	41
4	11570.00	58.39	74.00	-15.61	44.56	13.83	Peak	162	41
5	17355.00	61.55	68.20	-6.65	43.19	18.36	Peak	100	356

Note 1: Emission Level (dBuV/m) = SA Reading (dBuV/m) + Factor* (dB)

*Factor includes antenna factor , cable loss and amplifier gain

Note 2: Margin (dB) = Emission level (dBuV/m) – Limit (dBuV/m).

Modulation	VHT20	Test Freq. (MHz)	5785
Polarization	Vertical		

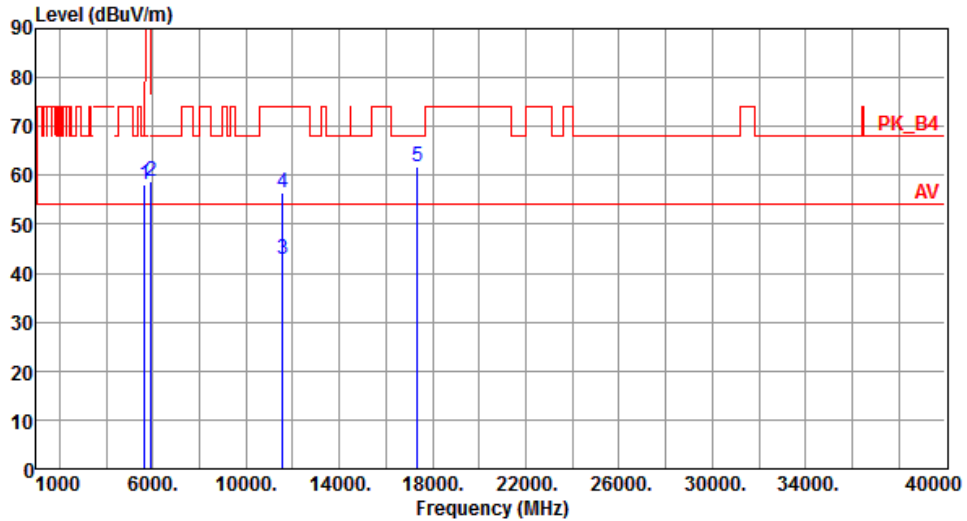

	Freq. MHz	Emission level dBuV/m	Limit dBuV/m	Margin dB	SA reading dBuV	Factor dB	Remark	ANT High cm	Turn Table deg
1	5650.00	58.19	68.20	-10.01	53.46	4.73	Peak	100	23
2	5925.00	58.82	68.20	-9.38	53.74	5.08	Peak	100	23
3	11570.00	42.73	54.00	-11.27	28.90	13.83	Average	136	237
4	11570.00	56.57	74.00	-17.43	42.74	13.83	Peak	136	237
5	17355.00	61.86	68.20	-6.34	43.50	18.36	Peak	100	29

Note 1: Emission Level (dBuV/m) = SA Reading (dBuV/m) + Factor* (dB)

*Factor includes antenna factor , cable loss and amplifier gain

Note 2: Margin (dB) = Emission level (dBuV/m) – Limit (dBuV/m).

Modulation	VHT20	Test Freq. (MHz)	5825
Polarization	Horizontal		

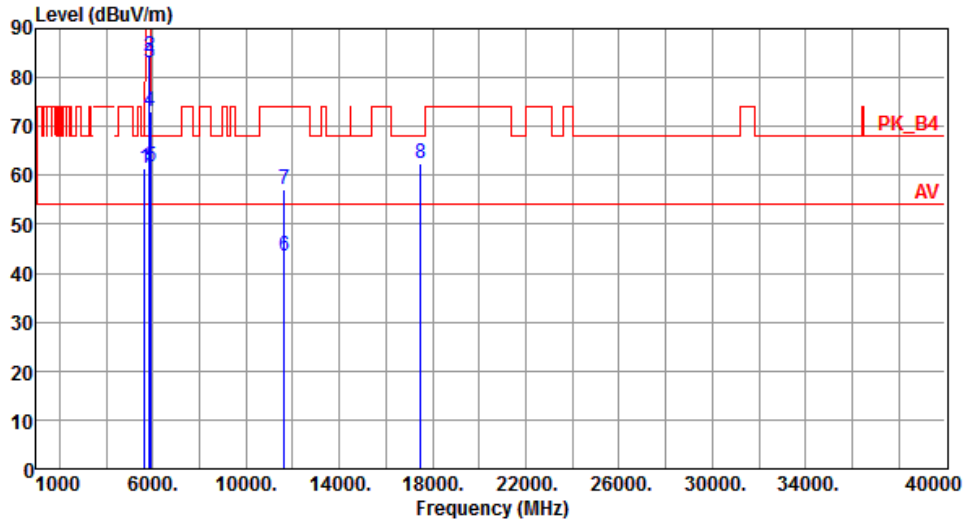

	Freq. MHz	Emission level dBuV/m	Limit dBuV/m	Margin dB	SA reading dBuV	Factor dB	Remark	ANT High cm	Turn Table deg
1	5650.00	61.34	68.20	-6.86	56.61	4.73	Peak	197	343
2	5850.00	84.30	122.20	-37.90	79.31	4.99	Peak	197	343
3	5855.00	82.96	110.80	-27.84	77.96	5.00	Peak	197	343
4	5875.00	73.15	105.20	-32.05	68.13	5.02	Peak	197	343
5	5925.00	61.79	68.20	-6.41	56.71	5.08	Peak	197	343
6	11650.00	43.43	54.00	-10.57	29.69	13.74	Average	100	34
7	11650.00	57.28	74.00	-16.72	43.54	13.74	Peak	100	34
8	17475.00	62.49	68.20	-5.71	43.80	18.69	Peak	100	352

Note 1: Emission Level (dBuV/m) = SA Reading (dBuV/m) + Factor* (dB)

*Factor includes antenna factor , cable loss and amplifier gain

Note 2: Margin (dB) = Emission level (dBuV/m) – Limit (dBuV/m).

Modulation	VHT20	Test Freq. (MHz)	5825
Polarization	Vertical		

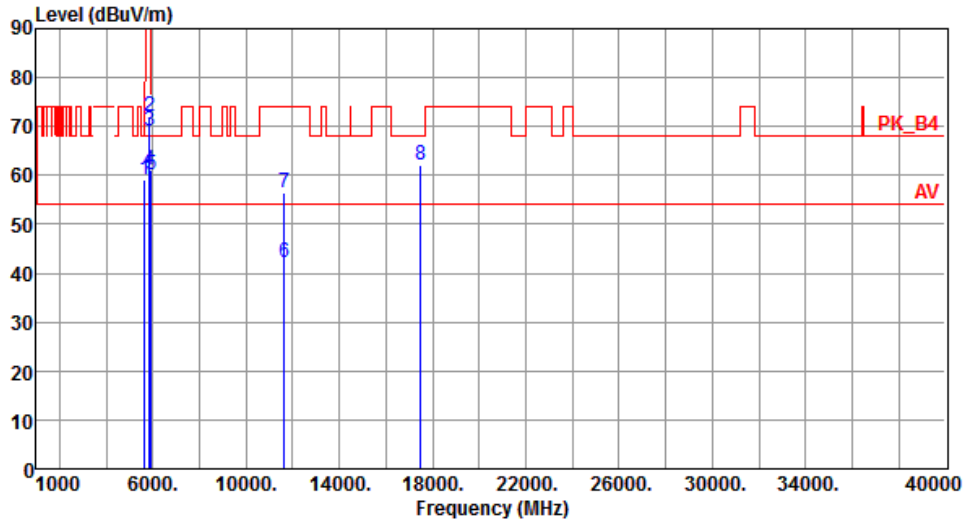

	Freq. MHz	Emission level dBuV/m	Limit dBuV/m	Margin dB	SA reading dBuV	Factor dB	Remark	ANT High cm	Turn Table deg
1	5650.00	58.96	68.20	-9.24	54.23	4.73	Peak	110	26
2	5850.00	72.18	122.20	-50.02	67.19	4.99	Peak	110	26
3	5855.00	68.94	110.80	-41.86	63.94	5.00	Peak	110	26
4	5875.00	61.16	105.20	-44.04	56.14	5.02	Peak	110	26
5	5925.00	60.13	68.20	-8.07	55.05	5.08	Peak	110	26
6	11650.00	42.21	54.00	-11.79	28.47	13.74	Average	100	229
7	11650.00	56.43	74.00	-17.57	42.69	13.74	Peak	100	229
8	17475.00	61.96	68.20	-6.24	43.27	18.69	Peak	100	35

Note 1: Emission Level (dBuV/m) = SA Reading (dBuV/m) + Factor* (dB)

*Factor includes antenna factor , cable loss and amplifier gain

Note 2: Margin (dB) = Emission level (dBuV/m) – Limit (dBuV/m).

3.5.12 Transmitter Radiated Unwanted Emissions (Above 1GHz) for VHT40

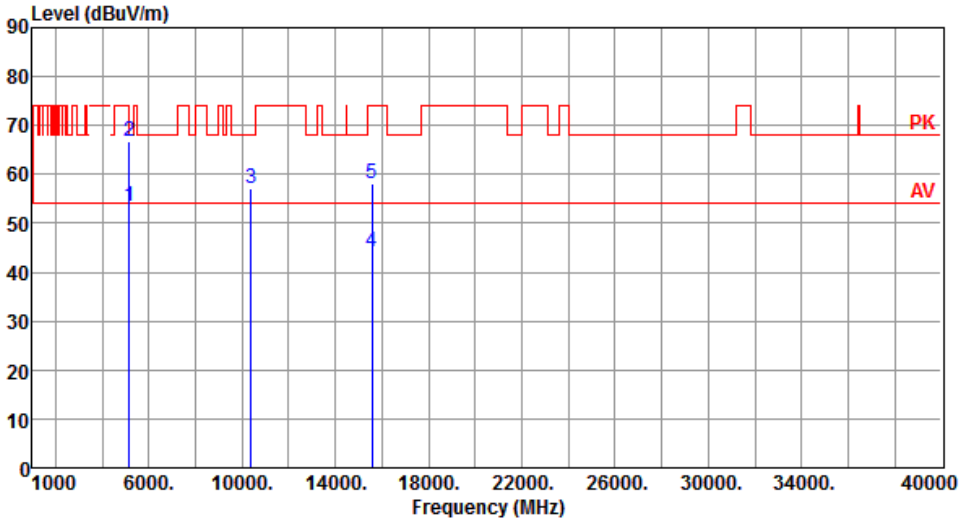
Modulation	VHT40	Test Freq. (MHz)	5190																																																																
Polarization	Horizontal																																																																		
																																																																			
	<table border="1"> <thead> <tr> <th>Freq.</th> <th>Emission level</th> <th>Limit</th> <th>Margin</th> <th>SA reading</th> <th>Factor</th> <th>Remark</th> <th>ANT High</th> <th>Turn Table</th> </tr> <tr> <th>MHz</th> <th>dBuV/m</th> <th>dBuV/m</th> <th>dB</th> <th>dBuV</th> <th>dB</th> <th></th> <th>cm</th> <th>deg</th> </tr> </thead> <tbody> <tr> <td>1</td> <td>53.44</td> <td>54.00</td> <td>-0.56</td> <td>49.20</td> <td>4.24</td> <td>Average</td> <td>207</td> <td>336</td> </tr> <tr> <td>2</td> <td>66.90</td> <td>74.00</td> <td>-7.10</td> <td>62.66</td> <td>4.24</td> <td>Peak</td> <td>207</td> <td>336</td> </tr> <tr> <td>3</td> <td>57.24</td> <td>68.20</td> <td>-10.96</td> <td>43.54</td> <td>13.70</td> <td>Peak</td> <td>100</td> <td>48</td> </tr> <tr> <td>4</td> <td>44.18</td> <td>54.00</td> <td>-9.82</td> <td>29.52</td> <td>14.66</td> <td>Average</td> <td>100</td> <td>3</td> </tr> <tr> <td>5</td> <td>58.24</td> <td>74.00</td> <td>-15.76</td> <td>43.58</td> <td>14.66</td> <td>Peak</td> <td>100</td> <td>3</td> </tr> </tbody> </table>	Freq.	Emission level	Limit	Margin	SA reading	Factor	Remark	ANT High	Turn Table	MHz	dBuV/m	dBuV/m	dB	dBuV	dB		cm	deg	1	53.44	54.00	-0.56	49.20	4.24	Average	207	336	2	66.90	74.00	-7.10	62.66	4.24	Peak	207	336	3	57.24	68.20	-10.96	43.54	13.70	Peak	100	48	4	44.18	54.00	-9.82	29.52	14.66	Average	100	3	5	58.24	74.00	-15.76	43.58	14.66	Peak	100	3			
Freq.	Emission level	Limit	Margin	SA reading	Factor	Remark	ANT High	Turn Table																																																											
MHz	dBuV/m	dBuV/m	dB	dBuV	dB		cm	deg																																																											
1	53.44	54.00	-0.56	49.20	4.24	Average	207	336																																																											
2	66.90	74.00	-7.10	62.66	4.24	Peak	207	336																																																											
3	57.24	68.20	-10.96	43.54	13.70	Peak	100	48																																																											
4	44.18	54.00	-9.82	29.52	14.66	Average	100	3																																																											
5	58.24	74.00	-15.76	43.58	14.66	Peak	100	3																																																											
<p>Note 1: Emission Level (dBuV/m) = SA Reading (dBuV/m) + Factor* (dB) *Factor includes antenna factor , cable loss and amplifier gain Note 2: Margin (dB) = Emission level (dBuV/m) – Limit (dBuV/m).</p>																																																																			

Modulation	VHT40	Test Freq. (MHz)	5190
Polarization	Vertical		

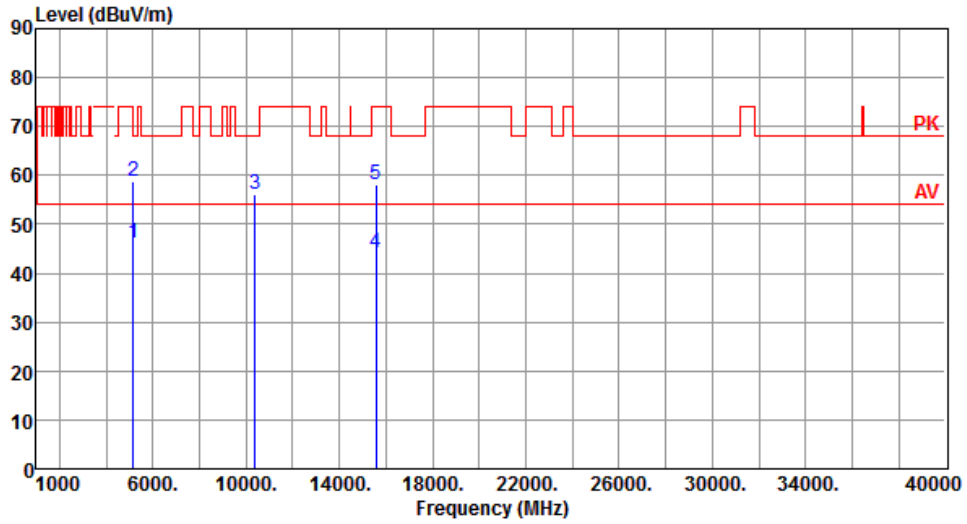

	Freq. MHz	Emission level dBuV/m	Limit dBuV/m	Margin dB	SA reading dBuV	Factor dB	Remark	ANT High cm	Turn Table deg
1	5150.00	46.31	54.00	-7.69	42.07	4.24	Average	100	32
2	5150.00	58.74	74.00	-15.26	54.50	4.24	Peak	100	32
3	10380.00	56.04	68.20	-12.16	42.34	13.70	Peak	100	239
4	15570.00	44.24	54.00	-9.76	29.58	14.66	Average	100	33
5	15570.00	58.19	74.00	-15.81	43.53	14.66	Peak	100	33

Note 1: Emission Level (dBuV/m) = SA Reading (dBuV/m) + Factor* (dB)

*Factor includes antenna factor , cable loss and amplifier gain

Note 2: Margin (dB) = Emission level (dBuV/m) – Limit (dBuV/m).

Modulation	VHT40	Test Freq. (MHz)	5230
Polarization	Horizontal		

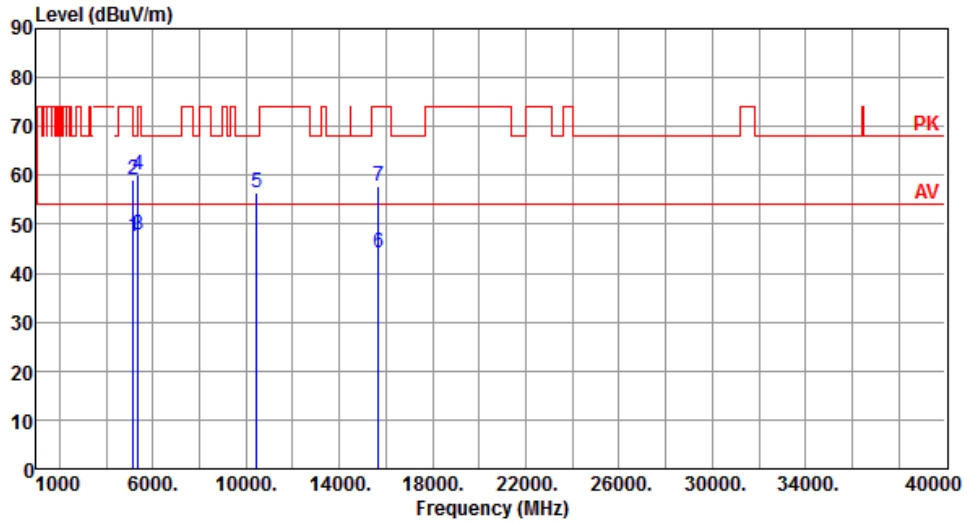

	Freq. MHz	Emission level dBuV/m	Limit dBuV/m	Margin dB	SA reading dBuV	Factor dB	Remark	ANT High cm	Turn Table deg
1	5150.00	47.38	54.00	-6.62	43.14	4.24	Average	201	352
2	5150.00	59.09	74.00	-14.91	54.85	4.24	Peak	201	352
3	5350.00	47.99	54.00	-6.01	43.56	4.43	Average	201	352
4	5350.00	59.99	74.00	-14.01	55.56	4.43	Peak	201	352
5	10460.00	56.59	68.20	-11.61	42.86	13.73	Peak	100	41
6	15690.00	44.17	54.00	-9.83	29.58	14.59	Average	100	1
7	15690.00	57.81	74.00	-16.19	43.22	14.59	Peak	100	1

Note 1: Emission Level (dBuV/m) = SA Reading (dBuV/m) + Factor* (dB)

*Factor includes antenna factor , cable loss and amplifier gain

Note 2: Margin (dB) = Emission level (dBuV/m) – Limit (dBuV/m).

Modulation	VHT40	Test Freq. (MHz)	5230
Polarization	Vertical		

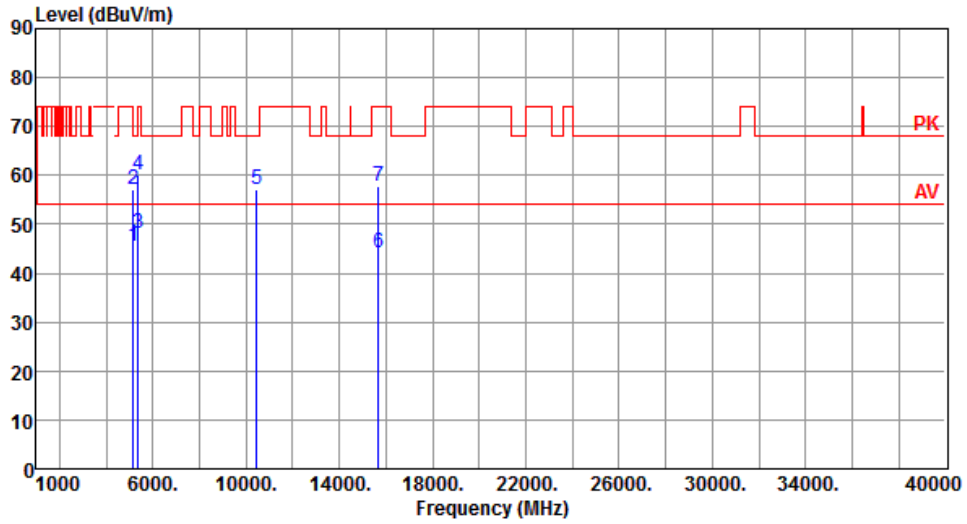

	Freq. MHz	Emission level dBuV/m	Limit dBuV/m	Margin dB	SA reading dBuV	Factor dB	Remark	ANT High cm	Turn Table deg
1	5150.00	45.50	54.00	-8.50	41.26	4.24	Average	100	31
2	5150.00	57.09	74.00	-16.91	52.85	4.24	Peak	100	31
3	5350.00	48.01	54.00	-5.99	43.58	4.43	Average	100	31
4	5350.00	60.12	74.00	-13.88	55.69	4.43	Peak	100	31
5	10460.00	56.97	68.20	-11.23	43.24	13.73	Peak	100	235
6	15690.00	44.27	54.00	-9.73	29.68	14.59	Average	100	28
7	15690.00	57.89	74.00	-16.11	43.30	14.59	Peak	100	28

Note 1: Emission Level (dBuV/m) = SA Reading (dBuV/m) + Factor* (dB)

*Factor includes antenna factor , cable loss and amplifier gain

Note 2: Margin (dB) = Emission level (dBuV/m) – Limit (dBuV/m).

Modulation	VHT40	Test Freq. (MHz)	5270
Polarization	Horizontal		

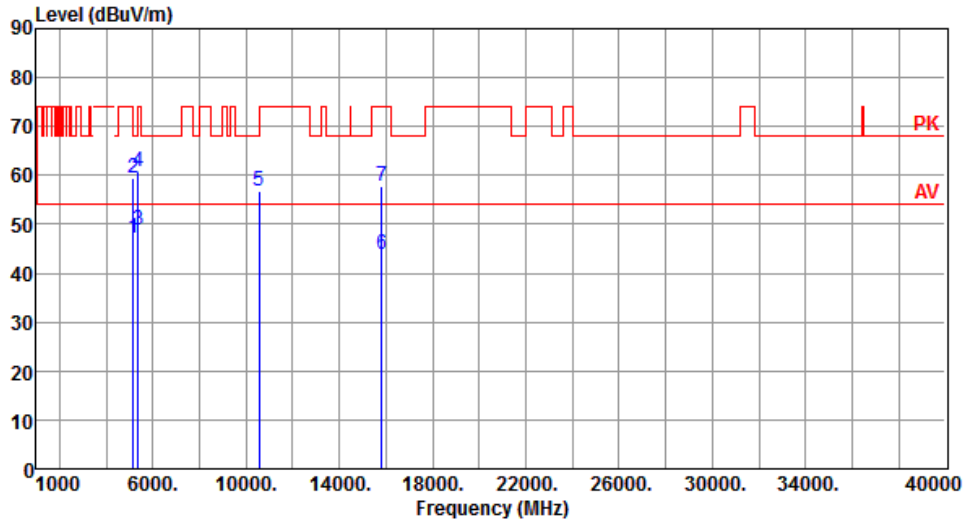

	Freq. MHz	Emission level dBuV/m	Limit dBuV/m	Margin dB	SA reading dBuV	Factor dB	Remark	ANT High cm	Turn Table deg
1	5150.00	47.22	54.00	-6.78	42.98	4.24	Average	209	348
2	5150.00	59.58	74.00	-14.42	55.34	4.24	Peak	209	348
3	5350.00	48.80	54.00	-5.20	44.37	4.43	Average	209	348
4	5350.00	60.85	74.00	-13.15	56.42	4.43	Peak	209	348
5	10540.00	56.67	68.20	-11.53	42.87	13.80	Peak	100	42
6	15810.00	43.76	54.00	-10.24	29.22	14.54	Average	100	358
7	15810.00	57.83	74.00	-16.17	43.29	14.54	Peak	100	358

Note 1: Emission Level (dBuV/m) = SA Reading (dBuV/m) + Factor* (dB)

*Factor includes antenna factor , cable loss and amplifier gain

Note 2: Margin (dB) = Emission level (dBuV/m) – Limit (dBuV/m).

Modulation	VHT40	Test Freq. (MHz)	5270
Polarization	Vertical		

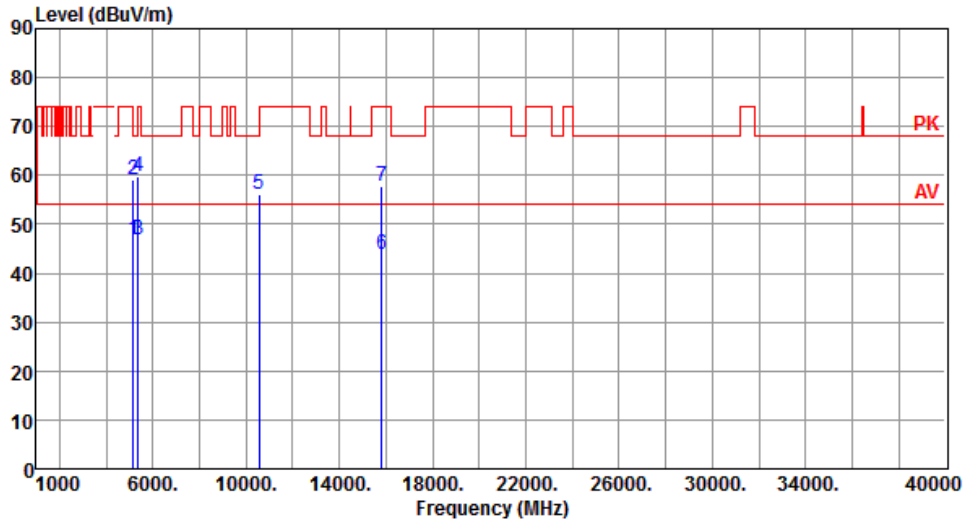

	Freq. MHz	Emission level dBuV/m	Limit dBuV/m	Margin dB	SA reading dBuV	Factor dB	Remark	ANT High cm	Turn Table deg
1	5150.00	46.79	54.00	-7.21	42.55	4.24	Average	100	29
2	5150.00	59.04	74.00	-14.96	54.80	4.24	Peak	100	29
3	5350.00	46.69	54.00	-7.31	42.26	4.43	Average	100	29
4	5350.00	59.72	74.00	-14.28	55.29	4.43	Peak	100	29
5	10540.00	56.01	68.20	-12.19	42.21	13.80	Peak	100	247
6	15810.00	43.70	54.00	-10.30	29.16	14.54	Average	100	32
7	15810.00	57.78	74.00	-16.22	43.24	14.54	Peak	100	32

Note 1: Emission Level (dBuV/m) = SA Reading (dBuV/m) + Factor* (dB)

*Factor includes antenna factor , cable loss and amplifier gain

Note 2: Margin (dB) = Emission level (dBuV/m) – Limit (dBuV/m).

Modulation	VHT40	Test Freq. (MHz)	5310
Polarization	Horizontal		

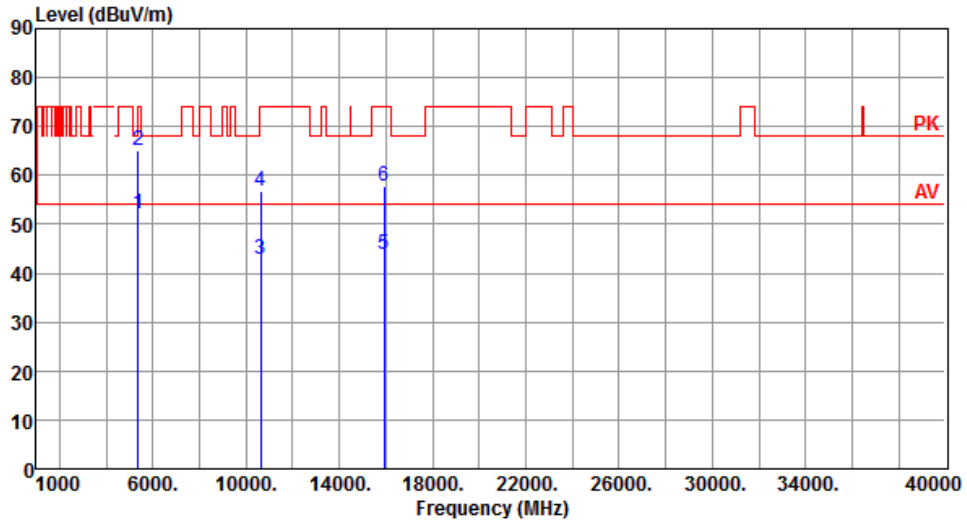

	Freq. MHz	Emission level dBuV/m	Limit dBuV/m	Margin dB	SA reading dBuV	Factor dB	Remark	ANT High cm	Turn Table deg
1	5350.00	52.08	54.00	-1.92	47.65	4.43	Average	200	359
2	5350.00	65.24	74.00	-8.76	60.81	4.43	Peak	200	359
3	10620.00	42.73	54.00	-11.27	28.84	13.89	Average	100	35
4	10620.00	56.83	74.00	-17.17	42.94	13.89	Peak	100	35
5	15930.00	44.00	54.00	-10.00	29.53	14.47	Average	100	2
6	15930.00	57.70	74.00	-16.30	43.23	14.47	Peak	100	2

Note 1: Emission Level (dBuV/m) = SA Reading (dBuV/m) + Factor* (dB)

*Factor includes antenna factor , cable loss and amplifier gain

Note 2: Margin (dB) = Emission level (dBuV/m) – Limit (dBuV/m).

Modulation	VHT40	Test Freq. (MHz)	5310
Polarization	Vertical		

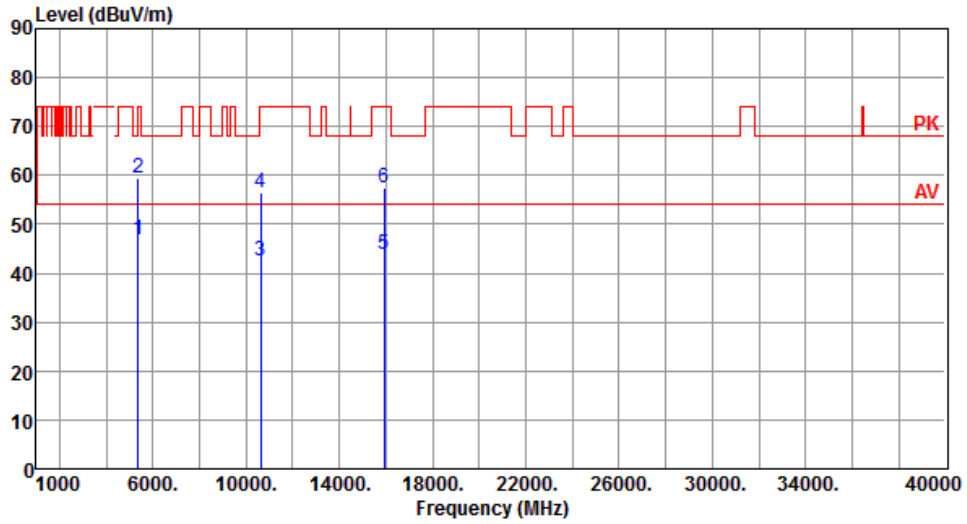

	Freq. MHz	Emission level dBuV/m	Limit dBuV/m	Margin dB	SA reading dBuV	Factor dB	Remark	ANT High cm	Turn Table deg
1	5350.00	46.85	54.00	-7.15	42.42	4.43	Average	100	28
2	5350.00	59.38	74.00	-14.62	54.95	4.43	Peak	100	28
3	10620.00	42.56	54.00	-11.44	28.67	13.89	Average	100	241
4	10620.00	56.57	74.00	-17.43	42.68	13.89	Peak	100	241
5	15930.00	43.70	54.00	-10.30	29.23	14.47	Average	100	33
6	15930.00	57.58	74.00	-16.42	43.11	14.47	Peak	100	33

Note 1: Emission Level (dBuV/m) = SA Reading (dBuV/m) + Factor* (dB)

*Factor includes antenna factor , cable loss and amplifier gain

Note 2: Margin (dB) = Emission level (dBuV/m) – Limit (dBuV/m).

Modulation	VHT40	Test Freq. (MHz)	5510
Polarization	Horizontal		

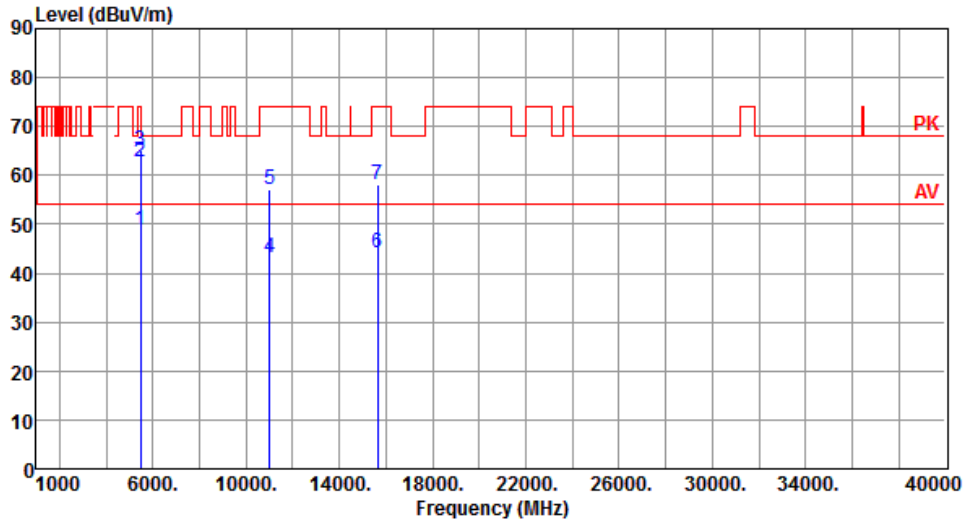

	Freq. MHz	Emission level dBuV/m	Limit dBuV/m	Margin dB	SA reading dBuV	Factor dB	Remark	ANT High cm	Turn Table deg
1	5460.00	48.75	54.00	-5.25	44.24	4.51	Average	201	334
2	5460.00	62.70	74.00	-11.30	58.19	4.51	Peak	201	334
3	5470.00	65.07	68.20	-3.13	60.55	4.52	Peak	201	334
4	11020.00	43.21	54.00	-10.79	28.89	14.32	Average	100	29
5	11020.00	57.10	74.00	-16.90	42.78	14.32	Peak	100	29
6	15630.00	44.27	54.00	-9.73	29.64	14.63	Average	100	245
7	15630.00	58.17	74.00	-15.83	43.54	14.63	Peak	100	245

Note 1: Emission Level (dBuV/m) = SA Reading (dBuV/m) + Factor* (dB)

*Factor includes antenna factor , cable loss and amplifier gain

Note 2: Margin (dB) = Emission level (dBuV/m) – Limit (dBuV/m).

Modulation	VHT40	Test Freq. (MHz)	5510
Polarization	Vertical		

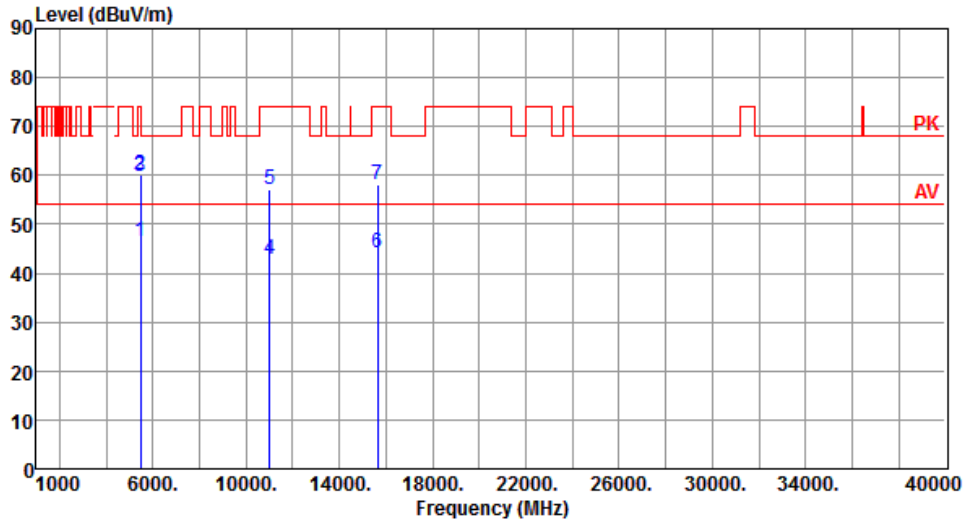

	Freq. MHz	Emission level dBuV/m	Limit dBuV/m	Margin dB	SA reading dBuV	Factor dB	Remark	ANT High cm	Turn Table deg
1	5460.00	46.34	54.00	-7.66	41.83	4.51	Average	100	27
2	5460.00	60.11	74.00	-13.89	55.60	4.51	Peak	100	27
3	5470.00	59.69	68.20	-8.51	55.17	4.52	Peak	100	27
4	11020.00	42.80	54.00	-11.20	28.48	14.32	Average	100	247
5	11020.00	57.01	74.00	-16.99	42.69	14.32	Peak	100	247
6	15630.00	44.27	54.00	-9.73	29.64	14.63	Average	100	24
7	15630.00	58.04	74.00	-15.96	43.41	14.63	Peak	100	24

Note 1: Emission Level (dBuV/m) = SA Reading (dBuV/m) + Factor* (dB)

*Factor includes antenna factor , cable loss and amplifier gain

Note 2: Margin (dB) = Emission level (dBuV/m) – Limit (dBuV/m).

Modulation	VHT40	Test Freq. (MHz)	5590
Polarization	Horizontal		

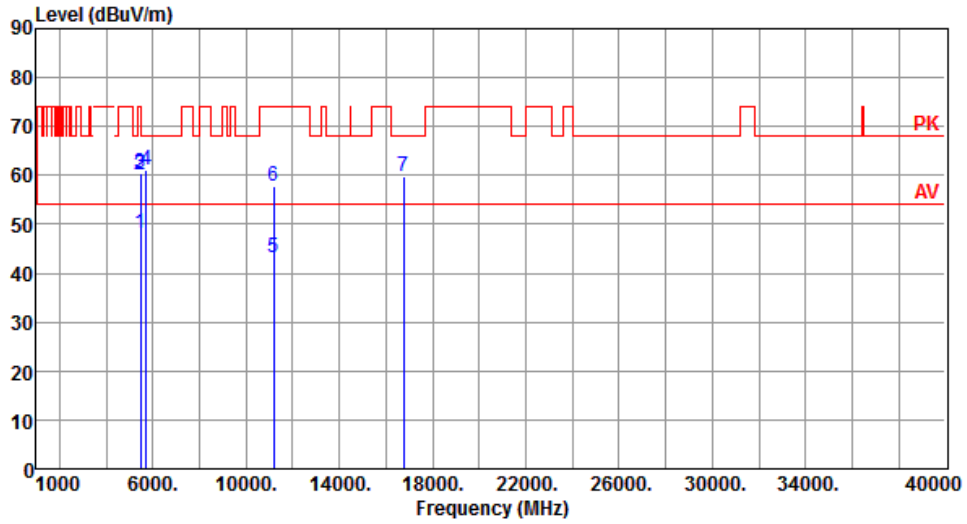

	Freq. MHz	Emission level dBuV/m	Limit dBuV/m	Margin dB	SA reading dBuV	Factor dB	Remark	ANT High cm	Turn Table deg
1	5460.00	48.01	54.00	-5.99	43.50	4.51	Average	225	341
2	5460.00	60.20	74.00	-13.80	55.69	4.51	Peak	225	341
3	5470.00	60.58	68.20	-7.62	56.06	4.52	Peak	225	341
4	5725.00	61.01	68.20	-7.19	56.19	4.82	Peak	225	341
5	11180.00	43.06	54.00	-10.94	28.87	14.19	Average	100	29
6	11180.00	57.77	74.00	-16.23	43.58	14.19	Peak	100	29
7	16770.00	59.66	68.20	-8.54	42.69	16.97	Peak	100	351

Note 1: Emission Level (dBuV/m) = SA Reading (dBuV/m) + Factor* (dB)

*Factor includes antenna factor , cable loss and amplifier gain

Note 2: Margin (dB) = Emission level (dBuV/m) – Limit (dBuV/m).

Modulation	VHT40	Test Freq. (MHz)	5590
Polarization	Vertical		

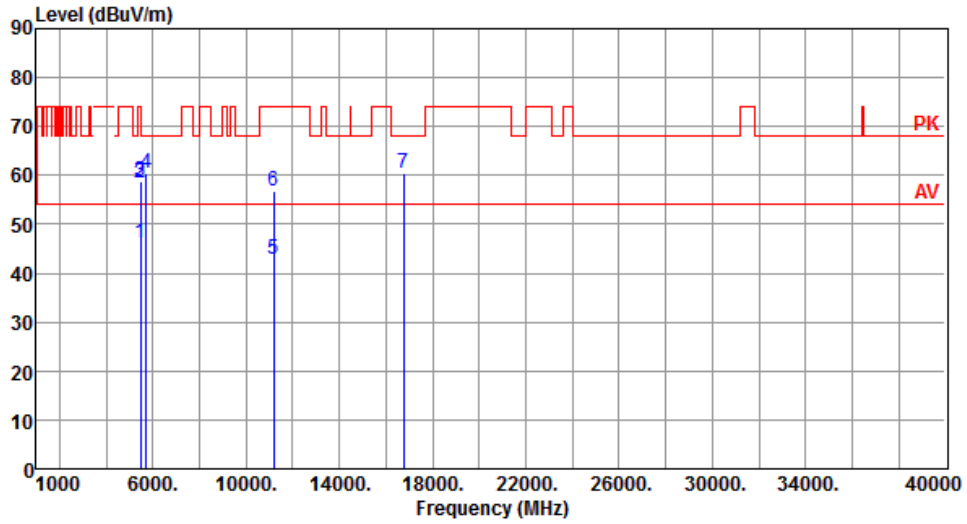

	Freq. MHz	Emission level dBuV/m	Limit dBuV/m	Margin dB	SA reading dBuV	Factor dB	Remark	ANT High cm	Turn Table deg
1	5460.00	46.06	54.00	-7.94	41.55	4.51	Average	100	28
2	5460.00	58.35	74.00	-15.65	53.84	4.51	Peak	100	28
3	5470.00	58.76	68.20	-9.44	54.24	4.52	Peak	100	28
4	5725.00	60.31	68.20	-7.89	55.49	4.82	Peak	100	28
5	11180.00	42.86	54.00	-11.14	28.67	14.19	Average	100	241
6	11180.00	56.88	74.00	-17.12	42.69	14.19	Peak	100	241
7	16770.00	60.51	68.20	-7.69	43.54	16.97	Peak	100	33

Note 1: Emission Level (dBuV/m) = SA Reading (dBuV/m) + Factor* (dB)

*Factor includes antenna factor , cable loss and amplifier gain

Note 2: Margin (dB) = Emission level (dBuV/m) – Limit (dBuV/m).

Modulation	VHT40	Test Freq. (MHz)	5670
Polarization	Horizontal		

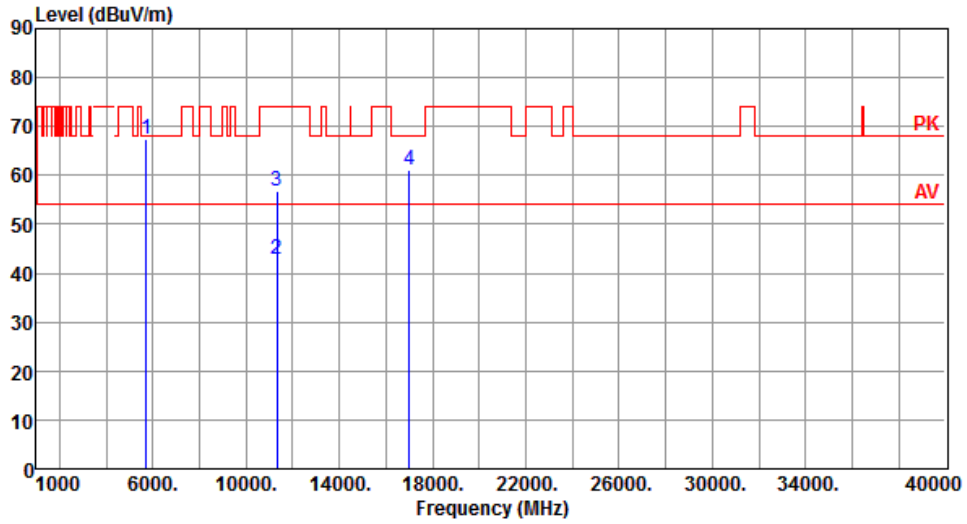

	Freq. MHz	Emission level dBuV/m	Limit dBuV/m	Margin dB	SA reading dBuV	Factor dB	Remark	ANT High cm	Turn Table deg
1	5725.00	67.46	68.20	-0.74	62.64	4.82	Peak	209	331
2	11340.00	42.72	54.00	-11.28	28.67	14.05	Average	100	34
3	11340.00	56.74	74.00	-17.26	42.69	14.05	Peak	100	34
4	17010.00	60.99	68.20	-7.21	43.58	17.41	Peak	100	338

Note 1: Emission Level (dBuV/m) = SA Reading (dBuV/m) + Factor* (dB)

*Factor includes antenna factor , cable loss and amplifier gain

Note 2: Margin (dB) = Emission level (dBuV/m) – Limit (dBuV/m).

Modulation	VHT40	Test Freq. (MHz)	5670
Polarization	Vertical		

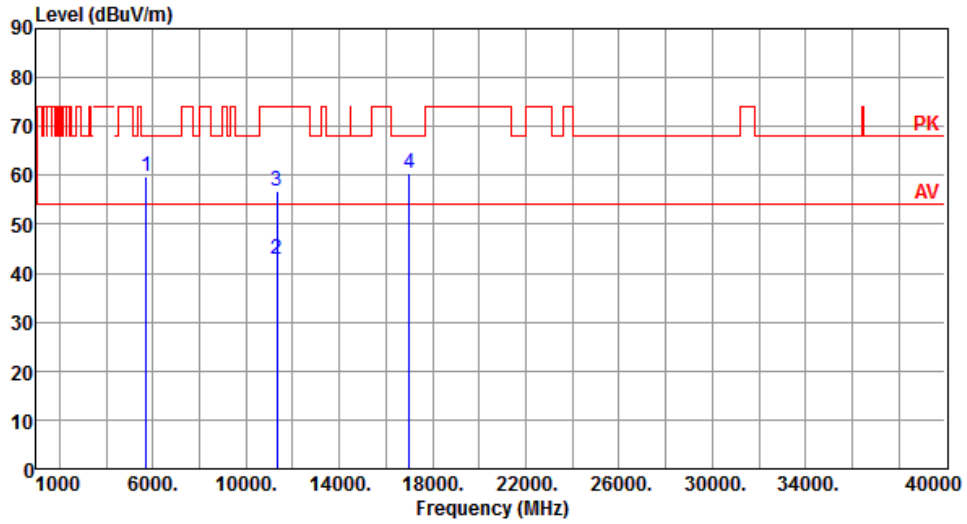

	Freq. MHz	Emission level dBuV/m	Limit dBuV/m	Margin dB	SA reading dBuV	Factor dB	Remark	ANT High cm	Turn Table deg
1	5725.00	59.85	68.20	-8.35	55.03	4.82	Peak	100	24
2	11340.00	42.74	54.00	-11.26	28.69	14.05	Average	100	249
3	11340.00	56.74	74.00	-17.26	42.69	14.05	Peak	100	249
4	17010.00	60.50	68.20	-7.70	43.09	17.41	Peak	100	29

Note 1: Emission Level (dBuV/m) = SA Reading (dBuV/m) + Factor* (dB)

*Factor includes antenna factor , cable loss and amplifier gain

Note 2: Margin (dB) = Emission level (dBuV/m) – Limit (dBuV/m).

Modulation	VHT40	Test Freq. (MHz)	5710
Polarization	Horizontal		

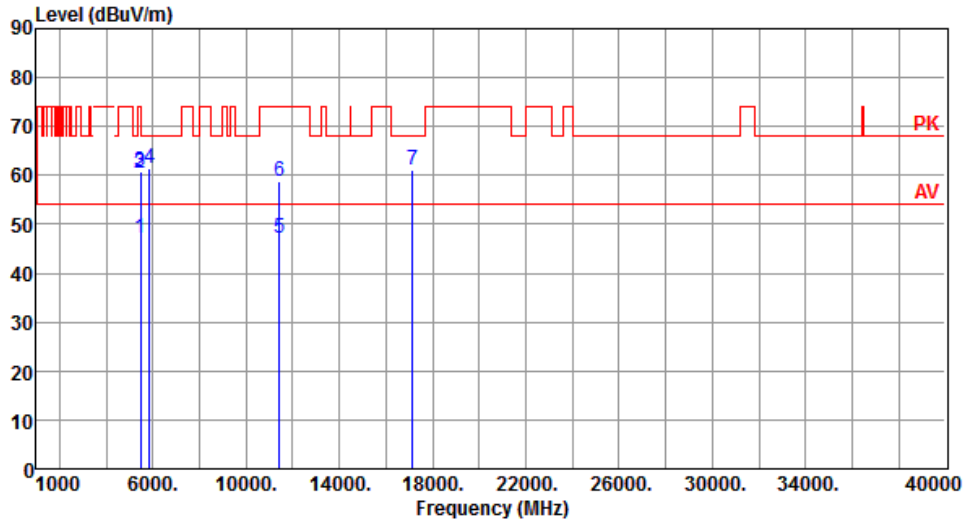

	Freq. MHz	Emission level dBuV/m	Limit dBuV/m	Margin dB	SA reading dBuV	Factor dB	Remark	ANT High cm	Turn Table deg
1	5460.00	47.11	54.00	-6.89	42.60	4.51	Average	216	188
2	5460.00	60.41	74.00	-13.59	55.90	4.51	Peak	216	188
3	5470.00	60.90	68.20	-7.30	56.38	4.52	Peak	216	188
4	5850.00	61.46	68.20	-6.74	56.47	4.99	Peak	216	188
5	11420.00	47.19	54.00	-6.81	33.22	13.97	Average	182	338
6	11420.00	58.82	74.00	-15.18	44.85	13.97	Peak	182	338
7	17130.00	61.25	68.20	-6.95	43.50	17.75	Peak	100	192

Note 1: Emission Level (dBuV/m) = SA Reading (dBuV/m) + Factor* (dB)

*Factor includes antenna factor , cable loss and amplifier gain

Note 2: Margin (dB) = Emission level (dBuV/m) – Limit (dBuV/m).

Modulation	VHT40	Test Freq. (MHz)	5710
Polarization	Vertical		

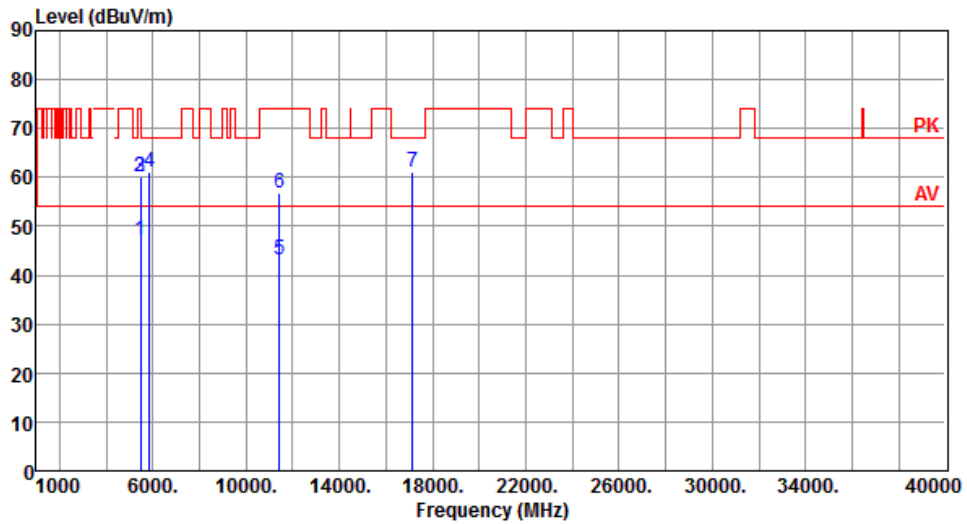

	Freq. MHz	Emission level dBuV/m	Limit dBuV/m	Margin dB	SA reading dBuV	Factor dB	Remark	ANT High cm	Turn Table deg
1	5460.00	47.16	54.00	-6.84	42.65	4.51	Average	196	259
2	5460.00	59.98	74.00	-14.02	55.47	4.51	Peak	196	259
3	5470.00	60.20	68.20	-8.00	55.68	4.52	Peak	196	259
4	5850.00	61.24	68.20	-6.96	56.25	4.99	Peak	196	259
5	11420.00	43.18	54.00	-10.82	29.21	13.97	Average	100	175
6	11420.00	56.87	74.00	-17.13	42.90	13.97	Peak	100	175
7	17130.00	60.99	68.20	-7.21	43.24	17.75	Peak	100	265

Note 1: Emission Level (dBuV/m) = SA Reading (dBuV/m) + Factor* (dB)

*Factor includes antenna factor , cable loss and amplifier gain

Note 2: Margin (dB) = Emission level (dBuV/m) – Limit (dBuV/m).

Modulation	VHT40	Test Freq. (MHz)	5755
Polarization	Horizontal		

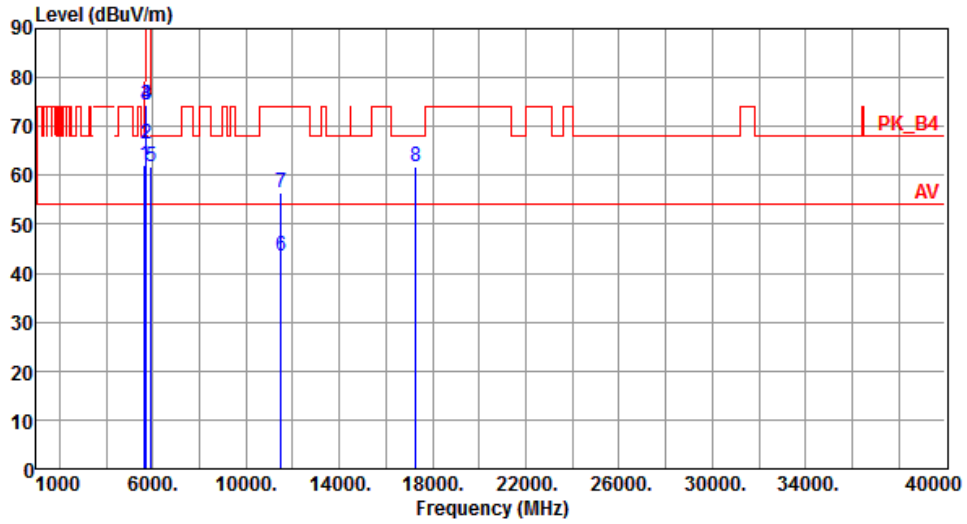

	Freq. MHz	Emission level dBuV/m	Limit dBuV/m	Margin dB	SA reading dBuV	Factor dB	Remark	ANT High cm	Turn Table deg
1	5650.00	62.05	68.20	-6.15	57.32	4.73	Peak	215	339
2	5700.00	66.38	105.20	-38.82	61.59	4.79	Peak	215	339
3	5720.00	74.40	110.80	-36.40	69.58	4.82	Peak	215	339
4	5725.00	74.39	122.20	-47.81	69.57	4.82	Peak	215	339
5	5925.00	61.62	68.20	-6.58	56.54	5.08	Peak	215	339
6	11510.00	43.44	54.00	-10.56	29.54	13.90	Average	100	36
7	11510.00	56.59	74.00	-17.41	42.69	13.90	Peak	100	36
8	17265.00	61.76	68.20	-6.44	43.64	18.12	Peak	100	348

Note 1: Emission Level (dBuV/m) = SA Reading (dBuV/m) + Factor* (dB)

*Factor includes antenna factor , cable loss and amplifier gain

Note 2: Margin (dB) = Emission level (dBuV/m) – Limit (dBuV/m).

Modulation	VHT40	Test Freq. (MHz)	5755
Polarization	Vertical		

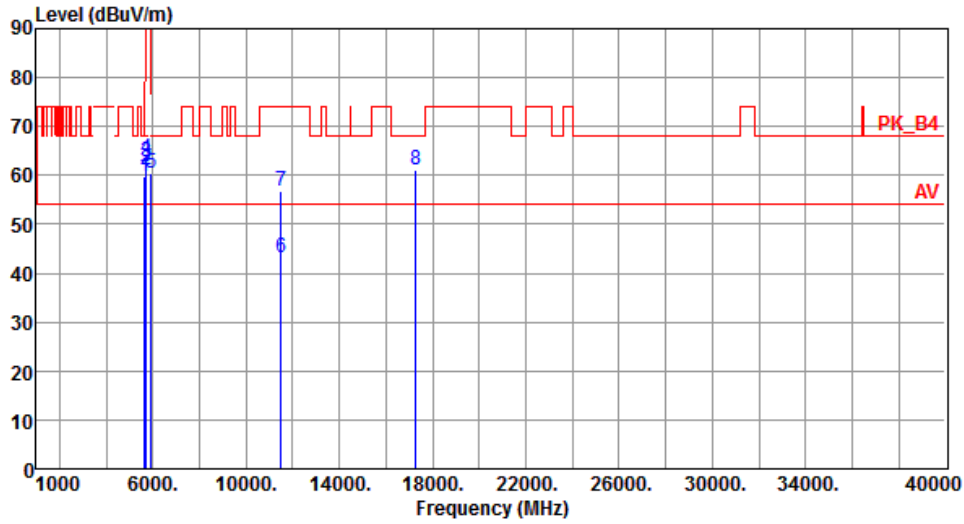

	Freq. MHz	Emission level dBuV/m	Limit dBuV/m	Margin dB	SA reading dBuV	Factor dB	Remark	ANT High cm	Turn Table deg
1	5650.00	59.71	68.20	-8.49	54.98	4.73	Peak	100	32
2	5700.00	60.97	105.20	-44.23	56.18	4.79	Peak	100	32
3	5720.00	62.93	110.80	-47.87	58.11	4.82	Peak	100	32
4	5725.00	63.56	122.20	-58.64	58.74	4.82	Peak	100	32
5	5925.00	60.41	68.20	-7.79	55.33	5.08	Peak	100	32
6	11510.00	43.24	54.00	-10.76	29.34	13.90	Average	100	241
7	11510.00	56.80	74.00	-17.20	42.90	13.90	Peak	100	241
8	17265.00	61.10	68.20	-7.10	42.98	18.12	Peak	100	33

Note 1: Emission Level (dBuV/m) = SA Reading (dBuV/m) + Factor* (dB)

*Factor includes antenna factor , cable loss and amplifier gain

Note 2: Margin (dB) = Emission level (dBuV/m) – Limit (dBuV/m).

Modulation	VHT40	Test Freq. (MHz)	5795
Polarization	Horizontal		

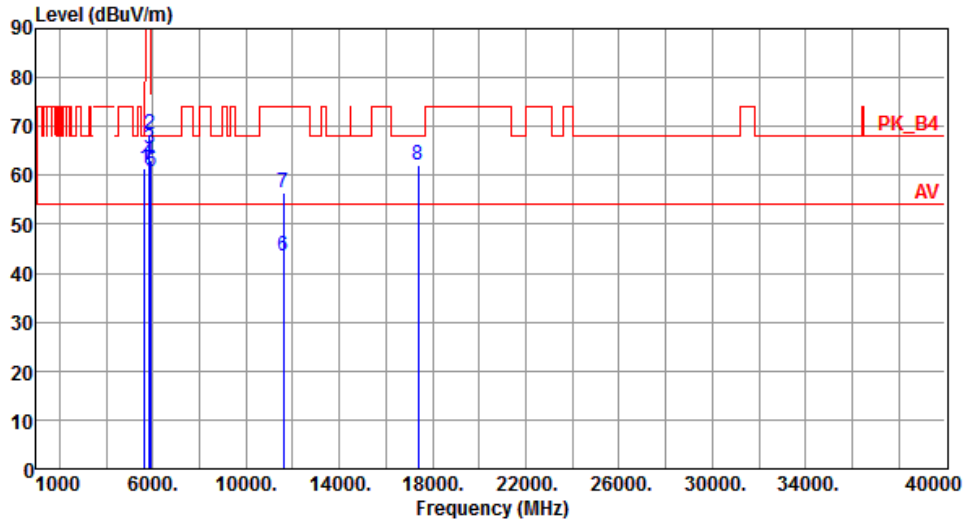

	Freq. MHz	Emission level dBuV/m	Limit dBuV/m	Margin dB	SA reading dBuV	Factor dB	Remark	ANT High cm	Turn Table deg
1	5650.00	61.28	68.20	-6.92	56.55	4.73	Peak	212	337
2	5850.00	68.43	122.20	-53.77	63.44	4.99	Peak	212	337
3	5855.00	65.56	110.80	-45.24	60.56	5.00	Peak	212	337
4	5875.00	63.06	105.20	-42.14	58.04	5.02	Peak	212	337
5	5925.00	60.63	68.20	-7.57	55.55	5.08	Peak	212	337
6	11590.00	43.36	54.00	-10.64	29.55	13.81	Average	100	34
7	11590.00	56.55	74.00	-17.45	42.74	13.81	Peak	100	34
8	17385.00	61.95	68.20	-6.25	43.50	18.45	Peak	100	357

Note 1: Emission Level (dBuV/m) = SA Reading (dBuV/m) + Factor* (dB)

*Factor includes antenna factor , cable loss and amplifier gain

Note 2: Margin (dB) = Emission level (dBuV/m) – Limit (dBuV/m).

Modulation	VHT40	Test Freq. (MHz)	5795
Polarization	Vertical		

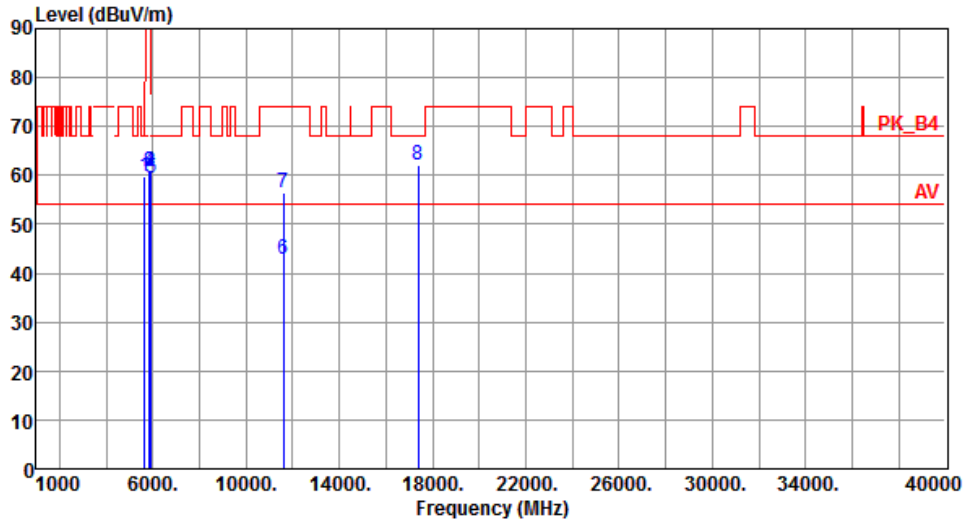

	Freq. MHz	Emission level dBuV/m	Limit dBuV/m	Margin dB	SA reading dBuV	Factor dB	Remark	ANT High cm	Turn Table deg
1	5650.00	59.74	68.20	-8.46	55.01	4.73	Peak	100	28
2	5850.00	60.62	122.20	-61.58	55.63	4.99	Peak	100	28
3	5855.00	60.88	110.80	-49.92	55.88	5.00	Peak	100	28
4	5875.00	60.61	105.20	-44.59	55.59	5.02	Peak	100	28
5	5925.00	59.51	68.20	-8.69	54.43	5.08	Peak	100	28
6	11590.00	42.70	54.00	-11.30	28.89	13.81	Average	100	243
7	11590.00	56.49	74.00	-17.51	42.68	13.81	Peak	100	243
8	17385.00	61.98	68.20	-6.22	43.53	18.45	Peak	100	243

Note 1: Emission Level (dBuV/m) = SA Reading (dBuV/m) + Factor* (dB)

*Factor includes antenna factor , cable loss and amplifier gain

Note 2: Margin (dB) = Emission level (dBuV/m) – Limit (dBuV/m).

3.5.13 Transmitter Radiated Unwanted Emissions (Above 1GHz) for VHT80

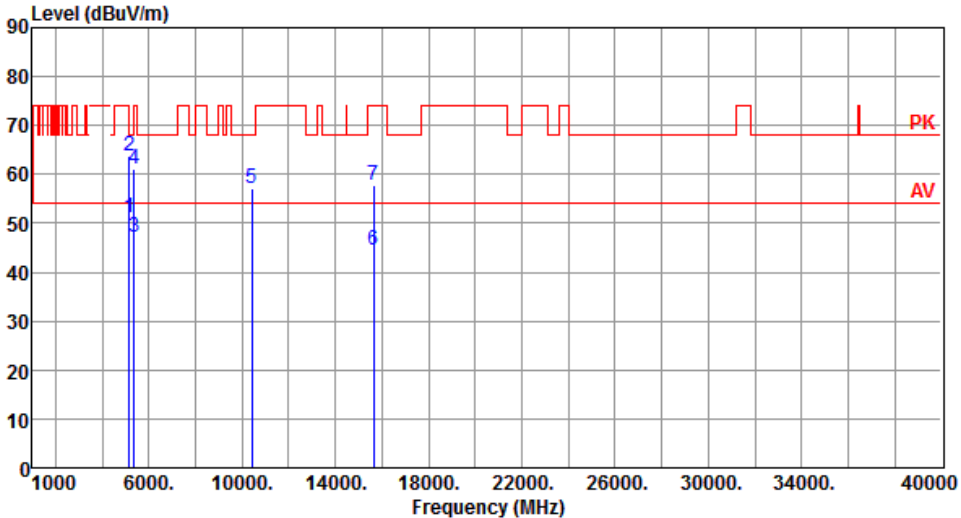
Modulation	VHT80	Test Freq. (MHz)	5210																																																																																							
Polarization	Horizontal																																																																																									
																																																																																										
	<table border="1"> <thead> <tr> <th>Freq.</th> <th>Emission level</th> <th>Limit</th> <th>Margin</th> <th>SA reading</th> <th>Factor</th> <th>Remark</th> <th>ANT High</th> <th>Turn Table</th> </tr> <tr> <th>MHz</th> <th>dBuV/m</th> <th>dBuV/m</th> <th>dB</th> <th>dBuV</th> <th>dB</th> <th></th> <th>cm</th> <th>deg</th> </tr> </thead> <tbody> <tr> <td>1</td> <td>5150.00</td> <td>51.05</td> <td>54.00</td> <td>-2.95</td> <td>46.81</td> <td>Average</td> <td>199</td> <td>338</td> </tr> <tr> <td>2</td> <td>5150.00</td> <td>63.78</td> <td>74.00</td> <td>-10.22</td> <td>59.54</td> <td>Peak</td> <td>199</td> <td>338</td> </tr> <tr> <td>3</td> <td>5350.00</td> <td>47.31</td> <td>54.00</td> <td>-6.69</td> <td>42.88</td> <td>Average</td> <td>199</td> <td>338</td> </tr> <tr> <td>4</td> <td>5350.00</td> <td>61.22</td> <td>74.00</td> <td>-12.78</td> <td>56.79</td> <td>Peak</td> <td>199</td> <td>338</td> </tr> <tr> <td>5</td> <td>10420.00</td> <td>56.96</td> <td>68.20</td> <td>-11.24</td> <td>43.24</td> <td>Peak</td> <td>100</td> <td>34</td> </tr> <tr> <td>6</td> <td>15630.00</td> <td>44.63</td> <td>54.00</td> <td>-9.37</td> <td>30.00</td> <td>Average</td> <td>100</td> <td>355</td> </tr> <tr> <td>7</td> <td>15630.00</td> <td>57.84</td> <td>74.00</td> <td>-16.16</td> <td>43.21</td> <td>Peak</td> <td>100</td> <td>355</td> </tr> </tbody> </table>	Freq.	Emission level	Limit	Margin	SA reading	Factor	Remark	ANT High	Turn Table	MHz	dBuV/m	dBuV/m	dB	dBuV	dB		cm	deg	1	5150.00	51.05	54.00	-2.95	46.81	Average	199	338	2	5150.00	63.78	74.00	-10.22	59.54	Peak	199	338	3	5350.00	47.31	54.00	-6.69	42.88	Average	199	338	4	5350.00	61.22	74.00	-12.78	56.79	Peak	199	338	5	10420.00	56.96	68.20	-11.24	43.24	Peak	100	34	6	15630.00	44.63	54.00	-9.37	30.00	Average	100	355	7	15630.00	57.84	74.00	-16.16	43.21	Peak	100	355								
Freq.	Emission level	Limit	Margin	SA reading	Factor	Remark	ANT High	Turn Table																																																																																		
MHz	dBuV/m	dBuV/m	dB	dBuV	dB		cm	deg																																																																																		
1	5150.00	51.05	54.00	-2.95	46.81	Average	199	338																																																																																		
2	5150.00	63.78	74.00	-10.22	59.54	Peak	199	338																																																																																		
3	5350.00	47.31	54.00	-6.69	42.88	Average	199	338																																																																																		
4	5350.00	61.22	74.00	-12.78	56.79	Peak	199	338																																																																																		
5	10420.00	56.96	68.20	-11.24	43.24	Peak	100	34																																																																																		
6	15630.00	44.63	54.00	-9.37	30.00	Average	100	355																																																																																		
7	15630.00	57.84	74.00	-16.16	43.21	Peak	100	355																																																																																		
<p>Note 1: Emission Level (dBuV/m) = SA Reading (dBuV/m) + Factor* (dB) *Factor includes antenna factor , cable loss and amplifier gain Note 2: Margin (dB) = Emission level (dBuV/m) – Limit (dBuV/m).</p>																																																																																										

Modulation	VHT80	Test Freq. (MHz)	5210
Polarization	Vertical		

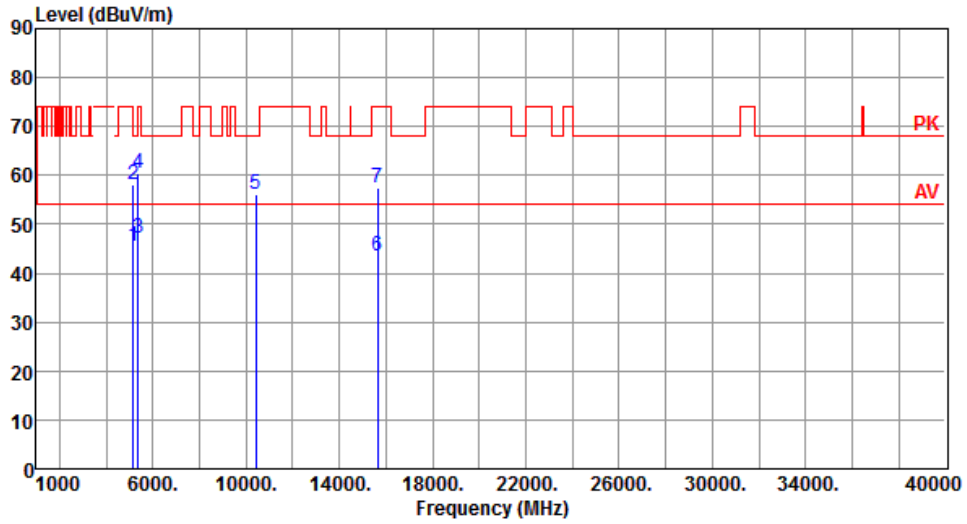

	Freq. MHz	Emission level dBuV/m	Limit dBuV/m	Margin dB	SA reading dBuV	Factor dB	Remark	ANT High cm	Turn Table deg
1	5150.00	45.65	54.00	-8.35	41.41	4.24	Average	100	25
2	5150.00	58.26	74.00	-15.74	54.02	4.24	Peak	100	25
3	5350.00	47.12	54.00	-6.88	42.69	4.43	Average	100	25
4	5350.00	60.31	74.00	-13.69	55.88	4.43	Peak	100	25
5	10420.00	56.06	68.20	-12.14	42.34	13.72	Peak	100	244
6	15630.00	43.63	54.00	-10.37	29.00	14.63	Average	100	41
7	15630.00	57.51	74.00	-16.49	42.88	14.63	Peak	100	41

Note 1: Emission Level (dBuV/m) = SA Reading (dBuV/m) + Factor* (dB)

*Factor includes antenna factor , cable loss and amplifier gain

Note 2: Margin (dB) = Emission level (dBuV/m) – Limit (dBuV/m).

Modulation	VHT80	Test Freq. (MHz)	5290
Polarization	Horizontal		

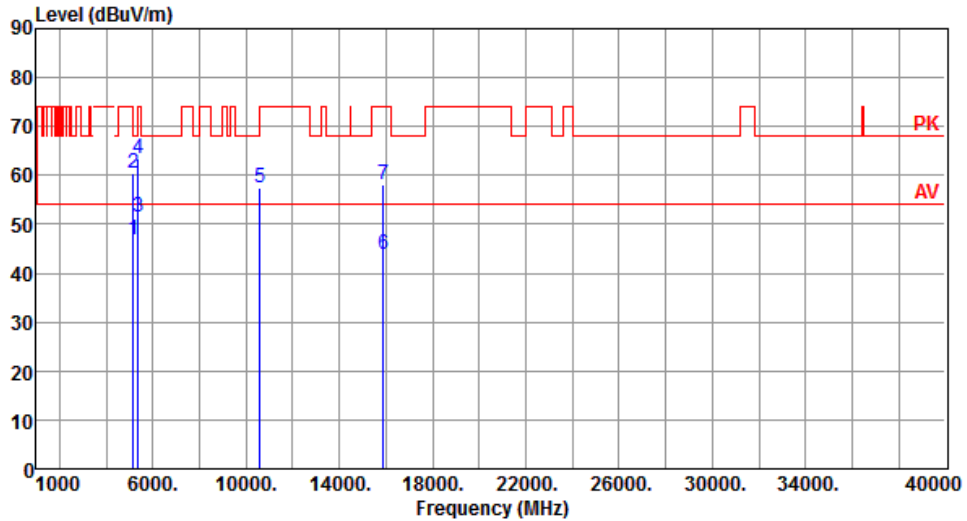

	Freq. MHz	Emission level dBuV/m	Limit dBuV/m	Margin dB	SA reading dBuV	Factor dB	Remark	ANT High cm	Turn Table deg
1	5150.00	46.78	54.00	-7.22	42.54	4.24	Average	201	334
2	5150.00	60.38	74.00	-13.62	56.14	4.24	Peak	201	334
3	5350.00	51.33	54.00	-2.67	46.90	4.43	Average	201	334
4	5350.00	63.35	74.00	-10.65	58.92	4.43	Peak	201	334
5	10580.00	57.53	68.20	-10.67	43.69	13.84	Peak	100	34
6	15870.00	43.81	54.00	-10.19	29.31	14.50	Average	100	351
7	15870.00	58.28	74.00	-15.72	43.78	14.50	Peak	100	351

Note 1: Emission Level (dBuV/m) = SA Reading (dBuV/m) + Factor* (dB)

*Factor includes antenna factor , cable loss and amplifier gain

Note 2: Margin (dB) = Emission level (dBuV/m) – Limit (dBuV/m).

Modulation	VHT80	Test Freq. (MHz)	5290
Polarization	Vertical		

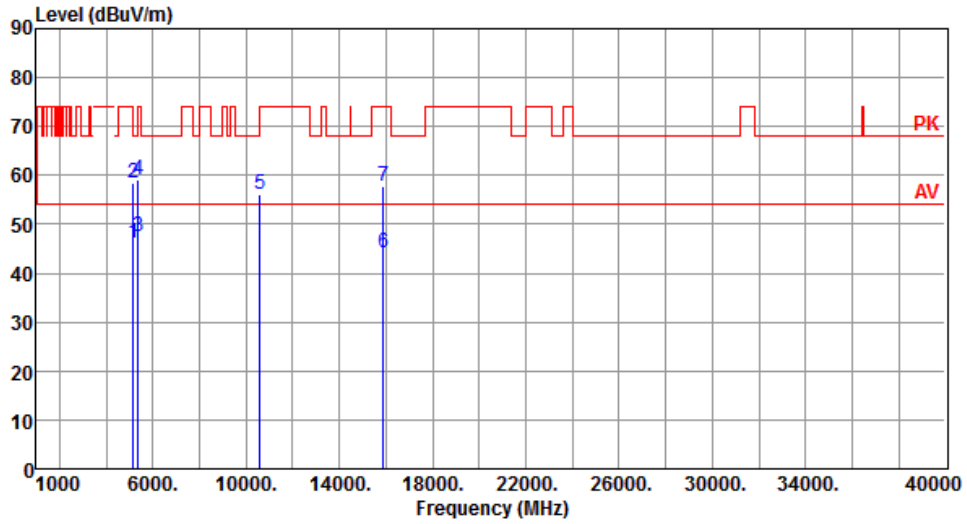

	Freq. MHz	Emission level dBuV/m	Limit dBuV/m	Margin dB	SA reading dBuV	Factor dB	Remark	ANT High cm	Turn Table deg
1	5150.00	46.22	54.00	-7.78	41.98	4.24	Average	100	26
2	5150.00	58.47	74.00	-15.53	54.23	4.24	Peak	100	26
3	5350.00	47.58	54.00	-6.42	43.15	4.43	Average	100	26
4	5350.00	59.03	74.00	-14.97	54.60	4.43	Peak	100	26
5	10580.00	56.28	68.20	-11.92	42.44	13.84	Peak	100	238
6	15870.00	44.10	54.00	-9.90	29.60	14.50	Average	100	353
7	15870.00	57.71	74.00	-16.29	43.21	14.50	Peak	100	353

Note 1: Emission Level (dBuV/m) = SA Reading (dBuV/m) + Factor* (dB)

*Factor includes antenna factor , cable loss and amplifier gain

Note 2: Margin (dB) = Emission level (dBuV/m) – Limit (dBuV/m).

Modulation	VHT80	Test Freq. (MHz)	5530
Polarization	Horizontal		

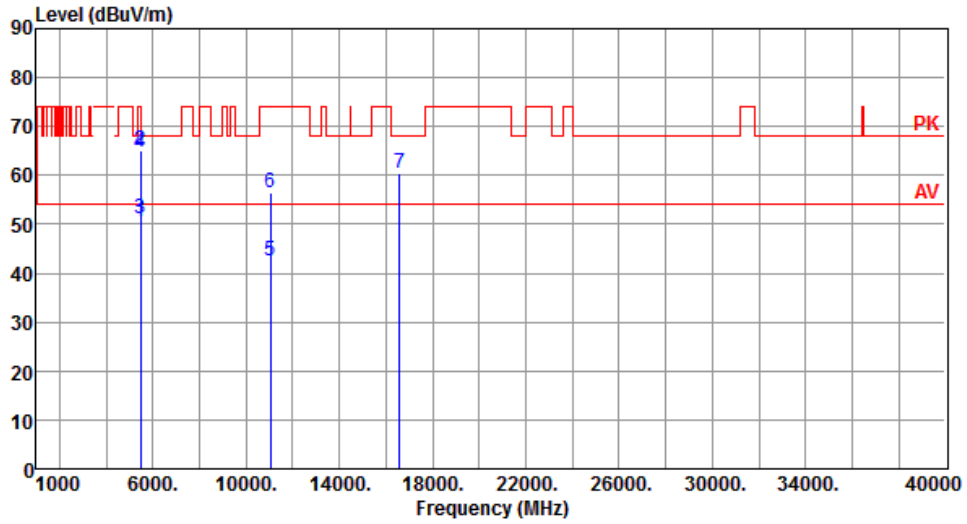

	Freq. MHz	Emission level dBuV/m	Limit dBuV/m	Margin dB	SA reading dBuV	Factor dB	Remark	ANT High cm	Turn Table deg
1	5460.00	50.57	54.00	-3.43	46.06	4.51	Average	204	333
2	5460.00	65.07	74.00	-8.93	60.56	4.51	Peak	204	333
3	5470.00	51.06	54.00	-2.94	46.54	4.52	Average	204	333
4	5470.00	64.76	68.20	-3.44	60.24	4.52	Peak	204	333
5	11060.00	42.56	54.00	-11.44	28.27	14.29	Average	100	38
6	11060.00	56.56	74.00	-17.44	42.27	14.29	Peak	100	38
7	16590.00	60.33	68.20	-7.87	43.69	16.64	Peak	100	358

Note 1: Emission Level (dBuV/m) = SA Reading (dBuV/m) + Factor* (dB)

*Factor includes antenna factor , cable loss and amplifier gain

Note 2: Margin (dB) = Emission level (dBuV/m) – Limit (dBuV/m).

Modulation	VHT80	Test Freq. (MHz)	5530
Polarization	Vertical		

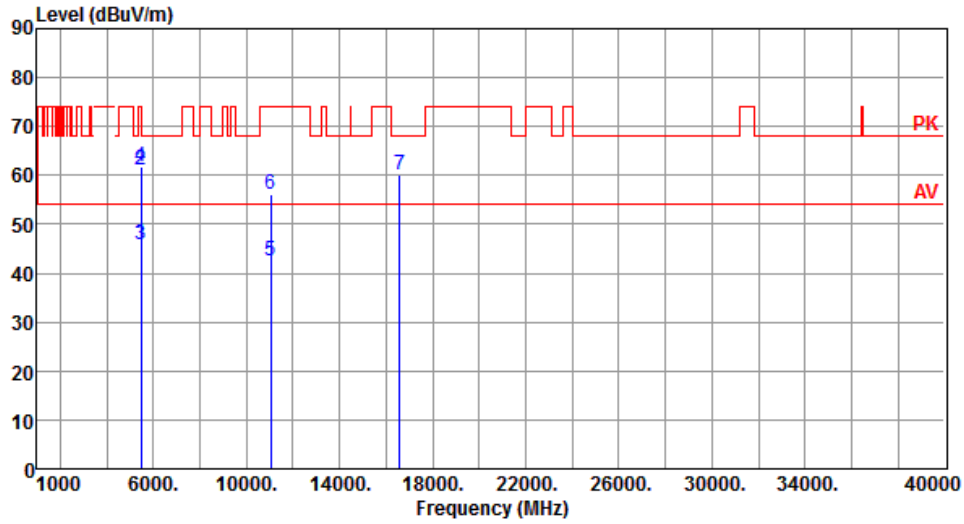

	Freq. MHz	Emission level dBuV/m	Limit dBuV/m	Margin dB	SA reading dBuV	Factor dB	Remark	ANT High cm	Turn Table deg
1	5460.00	46.18	54.00	-7.82	41.67	4.51	Average	100	24
2	5460.00	61.08	74.00	-12.92	56.57	4.51	Peak	100	24
3	5470.00	45.82	54.00	-8.18	41.30	4.52	Average	100	24
4	5470.00	61.79	68.20	-6.41	57.27	4.52	Peak	100	24
5	11060.00	42.47	54.00	-11.53	28.18	14.29	Average	100	241
6	11060.00	56.21	74.00	-17.79	41.92	14.29	Peak	100	241
7	16590.00	59.95	68.20	-8.25	43.31	16.64	Peak	100	35

Note 1: Emission Level (dBuV/m) = SA Reading (dBuV/m) + Factor* (dB)

*Factor includes antenna factor , cable loss and amplifier gain

Note 2: Margin (dB) = Emission level (dBuV/m) – Limit (dBuV/m).

Modulation	VHT80	Test Freq. (MHz)	5610
Polarization	Horizontal		

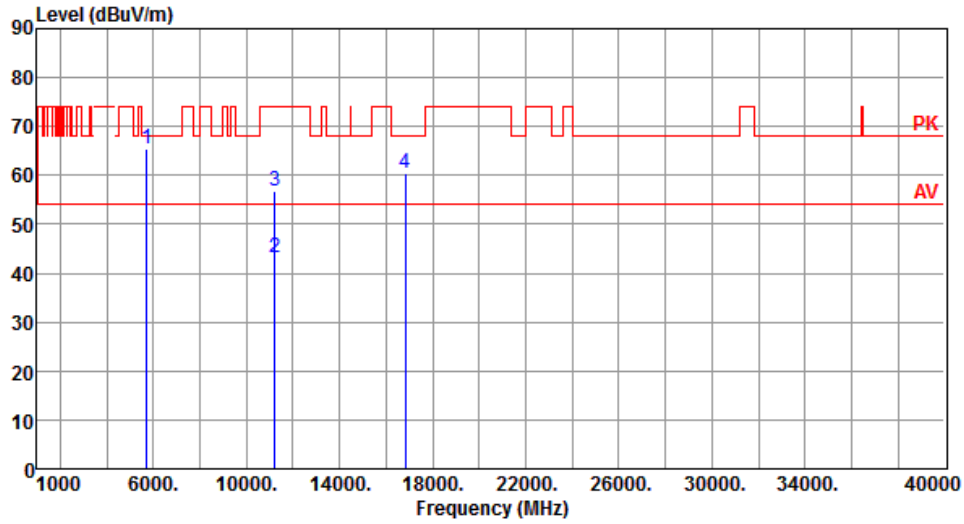

	Freq. MHz	Emission level dBuV/m	Limit dBuV/m	Margin dB	SA reading dBuV	Factor dB	Remark	ANT High cm	Turn Table deg
1	5725.00	65.54	68.20	-2.66	60.72	4.82	Peak	194	332
2	11220.00	43.09	54.00	-10.91	28.95	14.14	Average	100	48
3	11220.00	56.84	74.00	-17.16	42.70	14.14	Peak	100	48
4	16830.00	60.39	68.20	-7.81	43.31	17.08	Peak	100	351

Note 1: Emission Level (dBuV/m) = SA Reading (dBuV/m) + Factor* (dB)

*Factor includes antenna factor , cable loss and amplifier gain

Note 2: Margin (dB) = Emission level (dBuV/m) – Limit (dBuV/m).

Modulation	VHT80	Test Freq. (MHz)	5610
Polarization	Vertical		

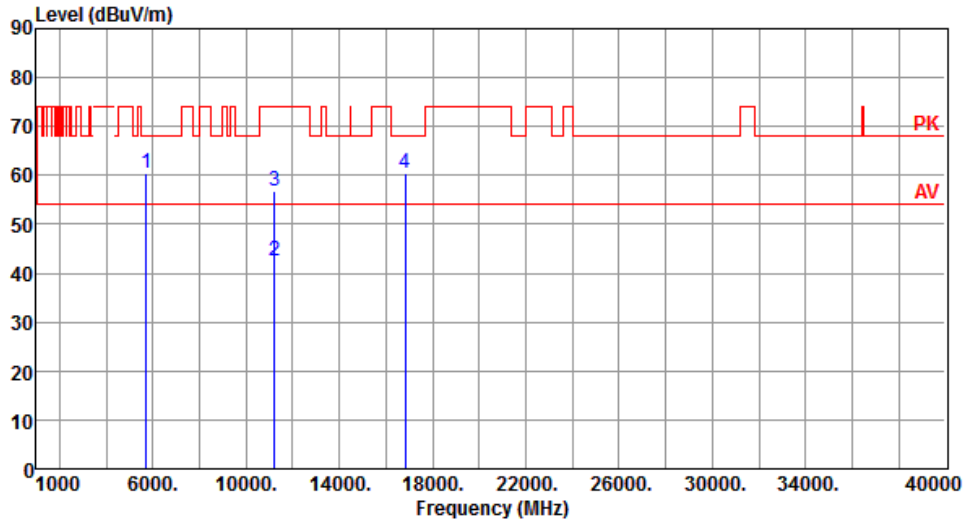

	Freq. MHz	Emission level dBuV/m	Limit dBuV/m	Margin dB	SA reading dBuV	Factor dB	Remark	ANT High cm	Turn Table deg
1	5725.00	60.54	68.20	-7.66	55.72	4.82	Peak	100	26
2	11220.00	42.56	54.00	-11.44	28.42	14.14	Average	100	29
3	11220.00	56.75	74.00	-17.25	42.61	14.14	Peak	100	29
4	16830.00	60.28	68.20	-7.92	43.20	17.08	Peak	100	348

Note 1: Emission Level (dBuV/m) = SA Reading (dBuV/m) + Factor* (dB)

*Factor includes antenna factor , cable loss and amplifier gain

Note 2: Margin (dB) = Emission level (dBuV/m) – Limit (dBuV/m).

Modulation	VHT80	Test Freq. (MHz)	5690
Polarization	Horizontal		

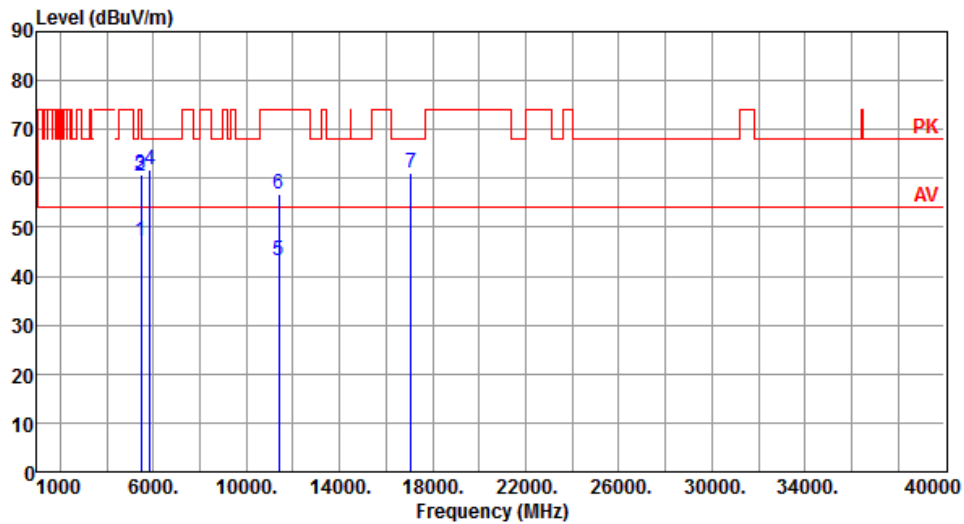

	Freq. MHz	Emission level dBuV/m	Limit dBuV/m	Margin dB	SA reading dBuV	Factor dB	Remark	ANT High cm	Turn Table deg
1	5460.00	47.20	54.00	-6.80	42.69	4.51	Average	227	200
2	5460.00	60.41	74.00	-13.59	55.90	4.51	Peak	227	200
3	5470.00	60.81	68.20	-7.39	56.29	4.52	Peak	227	200
4	5850.00	61.79	68.20	-6.41	56.80	4.99	Peak	227	200
5	11380.00	43.15	54.00	-10.85	29.13	14.02	Average	100	329
6	11380.00	56.70	74.00	-17.30	42.68	14.02	Peak	100	329
7	17070.00	61.16	68.20	-7.04	43.57	17.59	Peak	100	201

Note 1: Emission Level (dBuV/m) = SA Reading (dBuV/m) + Factor* (dB)

*Factor includes antenna factor , cable loss and amplifier gain

Note 2: Margin (dB) = Emission level (dBuV/m) – Limit (dBuV/m).

Modulation	VHT80	Test Freq. (MHz)	5690
Polarization	Vertical		

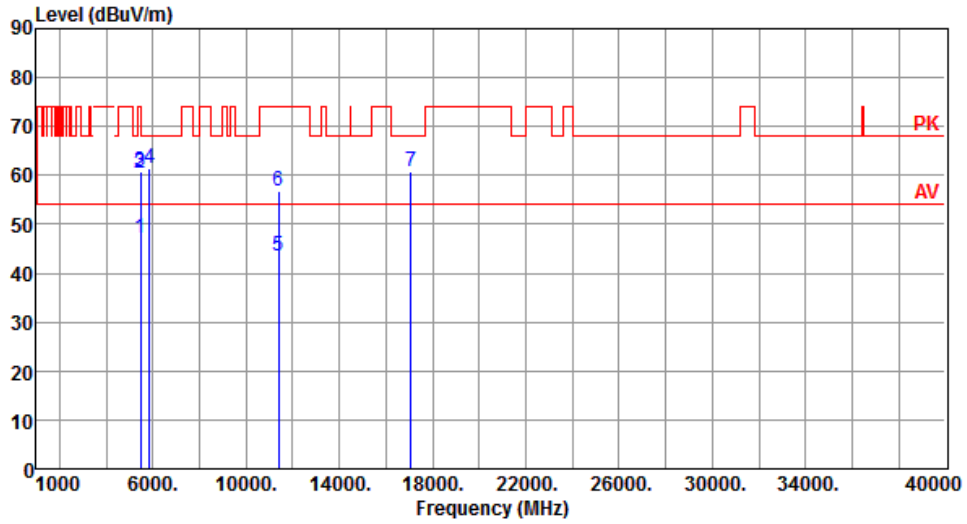

	Freq. MHz	Emission level dBuV/m	Limit dBuV/m	Margin dB	SA reading dBuV	Factor dB	Remark	ANT High cm	Turn Table deg
1	5460.00	47.15	54.00	-6.85	42.64	4.51	Average	289	247
2	5460.00	60.40	74.00	-13.60	55.89	4.51	Peak	289	247
3	5470.00	60.92	68.20	-7.28	56.40	4.52	Peak	289	247
4	5850.00	61.55	68.20	-6.65	56.56	4.99	Peak	289	247
5	11380.00	43.42	54.00	-10.58	29.40	14.02	Average	100	175
6	11380.00	56.70	74.00	-17.30	42.68	14.02	Peak	100	175
7	17070.00	60.82	68.20	-7.38	43.23	17.59	Peak	100	250

Note 1: Emission Level (dBuV/m) = SA Reading (dBuV/m) + Factor* (dB)

*Factor includes antenna factor , cable loss and amplifier gain

Note 2: Margin (dB) = Emission level (dBuV/m) – Limit (dBuV/m).

Modulation	VHT80	Test Freq. (MHz)	5775
Polarization	Horizontal		

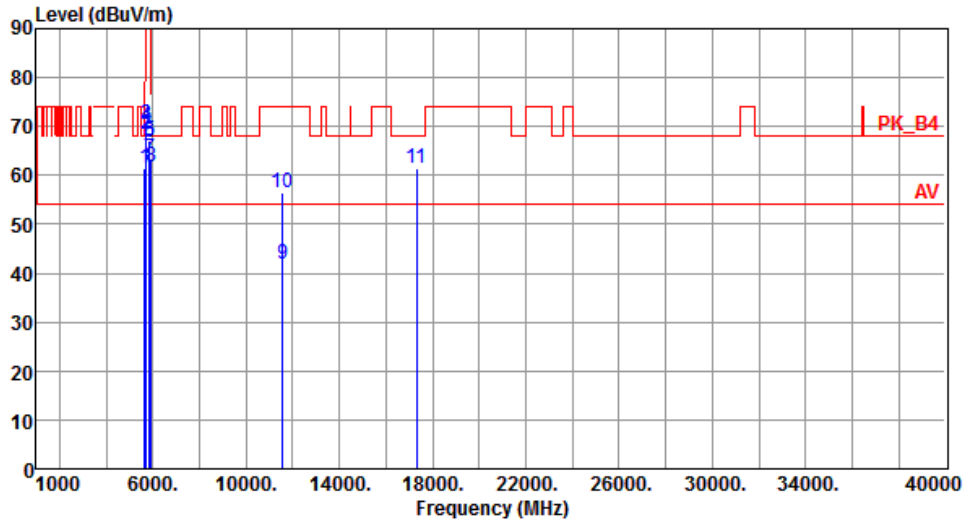

	Freq. MHz	Emission level dBuV/m	Limit dBuV/m	Margin dB	SA reading dBuV	Factor dB	Remark	ANT High cm	Turn Table deg
1	5650.00	61.59	68.20	-6.61	56.86	4.73	Peak	208	345
2	5700.00	68.35	105.20	-36.85	63.56	4.79	Peak	208	345
3	5720.00	70.28	110.80	-40.52	65.46	4.82	Peak	208	345
4	5725.00	70.08	122.20	-52.12	65.26	4.82	Peak	208	345
5	5850.00	67.18	122.20	-55.02	62.19	4.99	Peak	208	345
6	5855.00	66.71	110.80	-44.09	61.71	5.00	Peak	208	345
7	5875.00	63.49	105.20	-41.71	58.47	5.02	Peak	208	345
8	5925.00	61.93	68.20	-6.27	56.85	5.08	Peak	208	345
9	11550.00	41.85	54.00	-12.15	28.00	13.85	Average	100	34
10	11550.00	56.53	74.00	-17.47	42.68	13.85	Peak	100	34
11	17325.00	61.48	68.20	-6.72	43.20	18.28	Peak	100	354

Note 1: Emission Level (dBuV/m) = SA Reading (dBuV/m) + Factor* (dB)

*Factor includes antenna factor , cable loss and amplifier gain

Note 2: Margin (dB) = Emission level (dBuV/m) – Limit (dBuV/m).

Modulation	VHT80	Test Freq. (MHz)	5775
Polarization	Vertical		

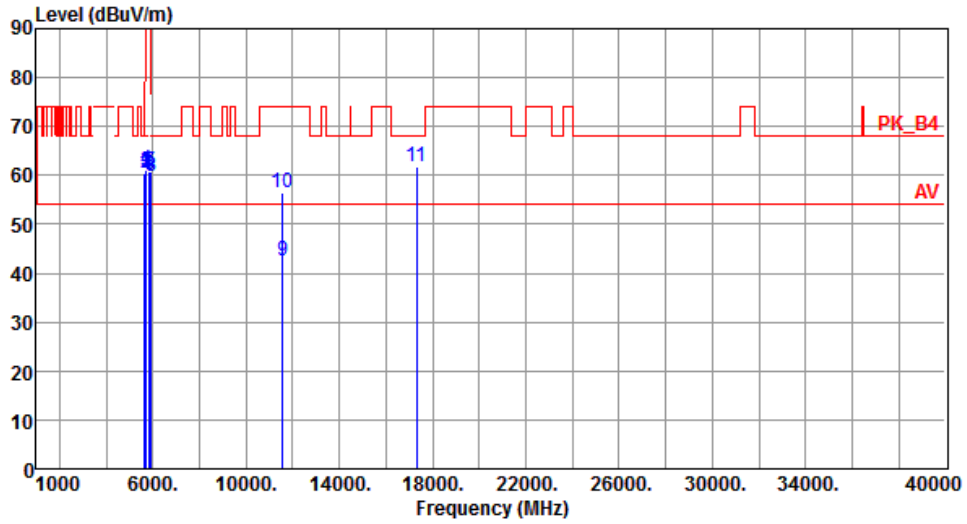

	Freq. MHz	Emission level dBuV/m	Limit dBuV/m	Margin dB	SA reading dBuV	Factor dB	Remark	ANT High cm	Turn Table deg
1	5650.00	60.59	68.20	-7.61	55.86	4.73	Peak	100	28
2	5700.00	60.36	105.20	-44.84	55.57	4.79	Peak	100	28
3	5720.00	60.87	110.80	-49.93	56.05	4.82	Peak	100	28
4	5725.00	60.99	122.20	-61.21	56.17	4.82	Peak	100	28
5	5850.00	60.68	122.20	-61.52	55.69	4.99	Peak	100	28
6	5855.00	60.07	110.80	-50.73	55.07	5.00	Peak	100	28
7	5875.00	60.66	105.20	-44.54	55.64	5.02	Peak	100	28
8	5925.00	59.85	68.20	-8.35	54.77	5.08	Peak	100	28
9	11550.00	42.49	54.00	-11.51	28.64	13.85	Average	100	249
10	11550.00	56.54	74.00	-17.46	42.69	13.85	Peak	100	249
11	17325.00	61.84	68.20	-6.36	43.56	18.28	Peak	100	31

Note 1: Emission Level (dBuV/m) = SA Reading (dBuV/m) + Factor* (dB)

*Factor includes antenna factor , cable loss and amplifier gain

Note 2: Margin (dB) = Emission level (dBuV/m) – Limit (dBuV/m).

Test Configuration 3

3.5.14 Transmitter Radiated Unwanted Emissions (Below 1GHz)

Modulation	VHT20	Test Freq. (MHz)	5240
Polarization	Horizontal		

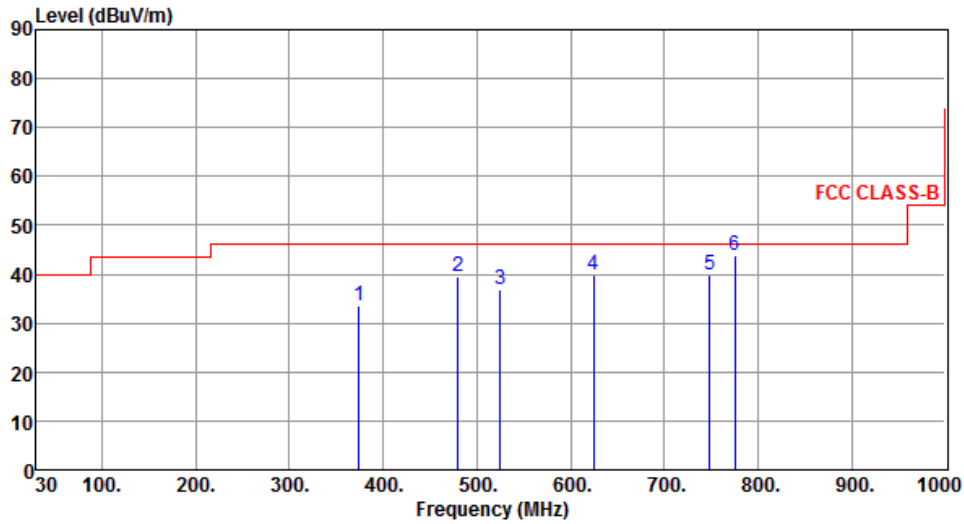

	Freq. MHz	Emission level dBuV/m	Limit dBuV/m	Margin dB	SA reading dBuV	Factor dB	Remark	ANT High cm	Turn Table deg
1	374.35	33.63	46.00	-12.37	39.59	-5.96	Peak	---	---
2	480.08	39.58	46.00	-6.42	43.16	-3.58	Peak	---	---
3	524.70	36.82	46.00	-9.18	39.57	-2.75	Peak	---	---
4	624.61	39.95	46.00	-6.05	40.40	-0.45	Peak	---	---
5	748.77	39.96	46.00	-6.04	38.16	1.80	Peak	---	---
6	775.02	43.96	46.00	-2.04	41.90	2.06	QP	100	151

Note 1: Emission Level (dBuV/m) = SA Reading (dBuV/m) + Factor* (dB)

*Factor includes antenna factor , cable loss and amplifier gain

Note 2: Margin (dB) = Emission level (dBuV/m) – Limit (dBuV/m).

Note 3: All spurious emissions below 30MHz are more than 20 dB below the limit.

Modulation	VHT20	Test Freq. (MHz)	5240
Polarization	Vertical		

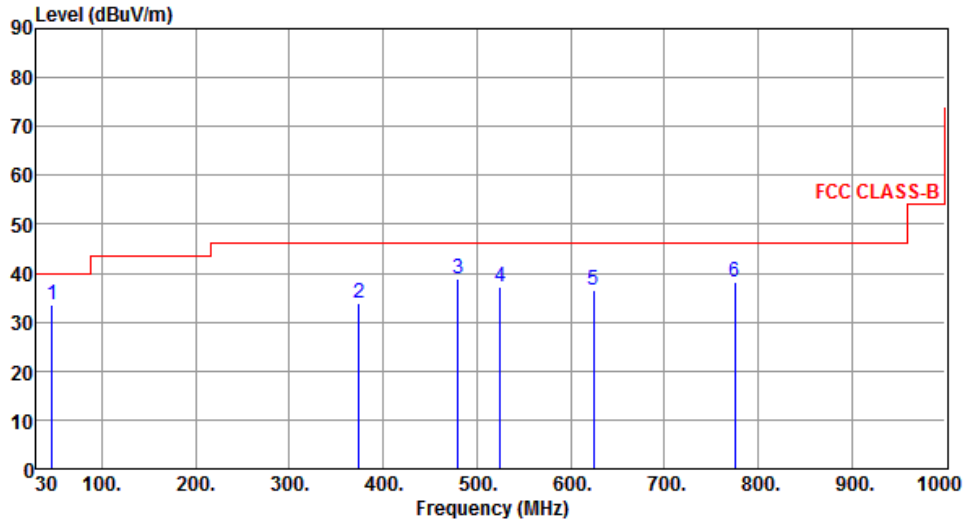

	Freq. MHz	Emission level dBuV/m	Limit dBuV/m	Margin dB	SA reading dBuV	Factor dB	Remark	ANT High cm	Turn Table deg
1	46.49	33.61	40.00	-6.39	41.72	-8.11	Peak	---	---
2	374.35	33.95	46.00	-12.05	39.91	-5.96	Peak	---	---
3	480.08	38.85	46.00	-7.15	42.43	-3.58	Peak	---	---
4	524.70	37.06	46.00	-8.94	39.81	-2.75	Peak	---	---
5	624.61	36.40	46.00	-9.60	36.85	-0.45	Peak	---	---
6	775.00	38.22	46.00	-7.78	36.17	2.05	Peak	---	---

Note 1: Emission Level (dBuV/m) = SA Reading (dBuV/m) + Factor* (dB)

*Factor includes antenna factor , cable loss and amplifier gain

Note 2: Margin (dB) = Emission level (dBuV/m) – Limit (dBuV/m).

Note 3: All spurious emissions below 30MHz are more than 20 dB below the limit.

Modulation	VHT20	Test Freq. (MHz)	5745
Polarization	Horizontal		

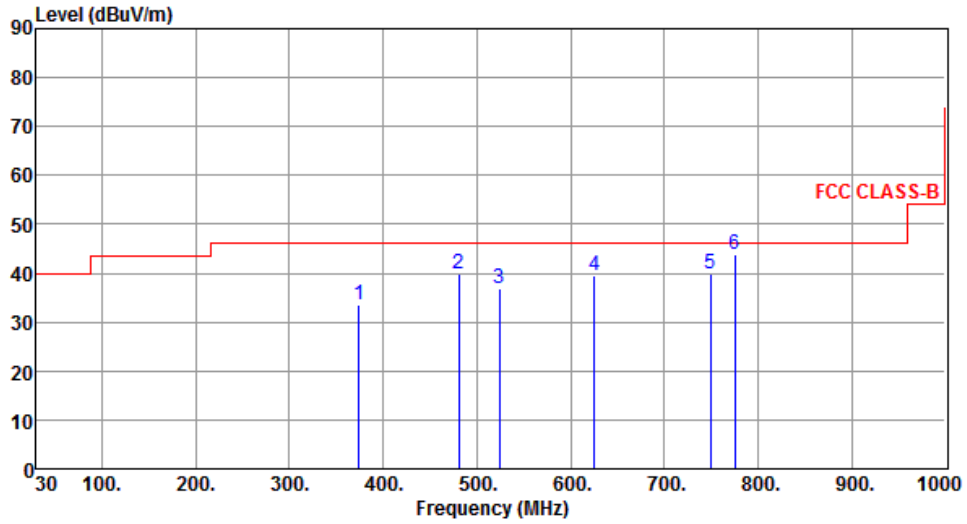

	Freq. MHz	Emission level dBuV/m	Limit dBuV/m	Margin dB	SA reading dBuV	Factor dB	Remark	ANT High cm	Turn Table deg
1	373.98	33.48	46.00	-12.52	39.44	-5.96	Peak	---	---
2	480.64	39.84	46.00	-6.16	43.41	-3.57	Peak	---	---
3	523.99	36.87	46.00	-9.13	39.64	-2.77	Peak	---	---
4	625.34	39.47	46.00	-6.53	39.91	-0.44	Peak	---	---
5	749.64	39.87	46.00	-6.13	38.06	1.81	Peak	---	---
6	775.10	43.86	46.00	-2.14	41.80	2.06	QP	100	150

Note 1: Emission Level (dBuV/m) = SA Reading (dBuV/m) + Factor* (dB)

*Factor includes antenna factor , cable loss and amplifier gain

Note 2: Margin (dB) = Emission level (dBuV/m) – Limit (dBuV/m).

Note 3: All spurious emissions below 30MHz are more than 20 dB below the limit.

Modulation	VHT20	Test Freq. (MHz)	5745
Polarization	Vertical		

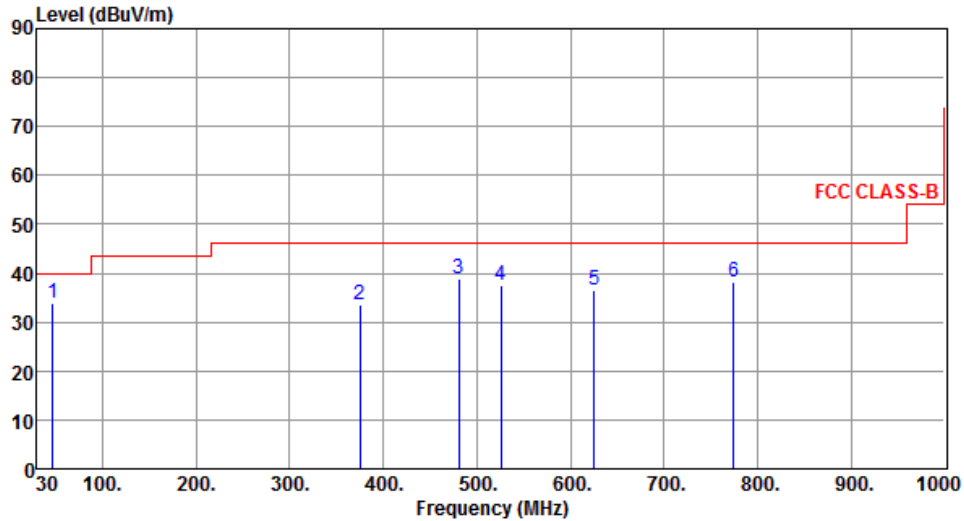

	Freq. MHz	Emission level dBuV/m	Limit dBuV/m	Margin dB	SA reading dBuV	Factor dB	Remark	ANT High cm	Turn Table deg
1	46.44	33.77	40.00	-6.23	41.88	-8.11	Peak	---	---
2	375.11	33.58	46.00	-12.42	39.51	-5.93	Peak	---	---
3	480.66	38.99	46.00	-7.01	42.56	-3.57	Peak	---	---
4	525.47	37.51	46.00	-8.49	40.24	-2.73	Peak	---	---
5	625.11	36.47	46.00	-9.53	36.91	-0.44	Peak	---	---
6	774.58	38.34	46.00	-7.66	36.29	2.05	Peak	---	---

Note 1: Emission Level (dBuV/m) = SA Reading (dBuV/m) + Factor* (dB)

*Factor includes antenna factor , cable loss and amplifier gain

Note 2: Margin (dB) = Emission level (dBuV/m) – Limit (dBuV/m).

Note 3: All spurious emissions below 30MHz are more than 20 dB below the limit.

3.5.15 Transmitter Radiated Unwanted Emissions (Above 1GHz) for 11a

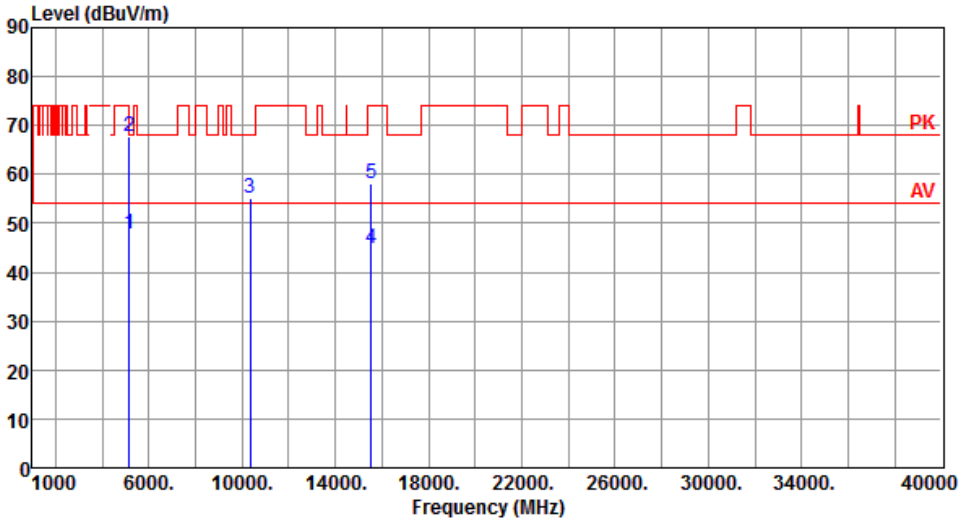
Modulation	11a	Test Freq. (MHz)	5180						
Polarization	Horizontal								
									
	Freq.	Emission level	Limit	Margin	SA reading	Factor	Remark	ANT High	Turn Table
	MHz	dBuV/m	dBuV/m	dB	dBuV	dB		cm	deg
1	5150.00	47.79	54.00	-6.21	43.55	4.24	Average	215	211
2	5150.00	67.69	74.00	-6.31	63.45	4.24	Peak	215	211
3	10360.00	55.27	68.20	-12.93	41.58	13.69	Peak	100	60
4	15540.00	44.95	54.00	-9.05	30.26	14.69	Average	100	80
5	15540.00	57.97	74.00	-16.03	43.28	14.69	Peak	100	80
<p>Note 1: Emission Level (dBuV/m) = SA Reading (dBuV/m) + Factor* (dB) *Factor includes antenna factor , cable loss and amplifier gain Note 2: Margin (dB) = Emission level (dBuV/m) – Limit (dBuV/m).</p>									

Modulation	11a	Test Freq. (MHz)	5180
Polarization	Vertical		

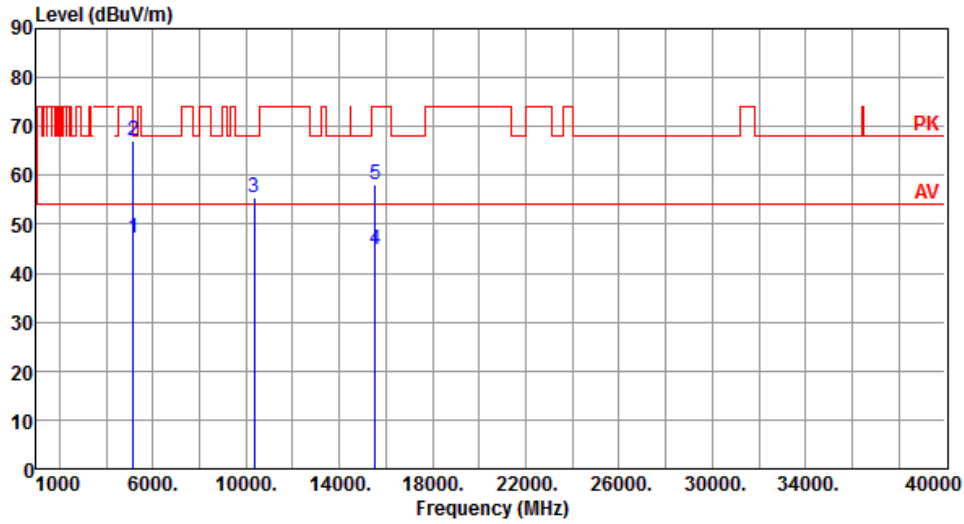

	Freq. MHz	Emission level dBuV/m	Limit dBuV/m	Margin dB	SA reading dBuV	Factor dB	Remark	ANT High cm	Turn Table deg
1	5150.00	47.25	54.00	-6.75	43.01	4.24	Average	128	82
2	5150.00	66.96	74.00	-7.04	62.72	4.24	Peak	128	82
3	10360.00	55.38	68.20	-12.82	41.69	13.69	Peak	100	20
4	15540.00	44.95	54.00	-9.05	30.26	14.69	Average	100	30
5	15540.00	58.16	74.00	-15.84	43.47	14.69	Peak	100	30

Note 1: Emission Level (dBuV/m) = SA Reading (dBuV/m) + Factor* (dB)

*Factor includes antenna factor , cable loss and amplifier gain

Note 2: Margin (dB) = Emission level (dBuV/m) – Limit (dBuV/m).

Modulation	11a	Test Freq. (MHz)	5200
Polarization	Horizontal		

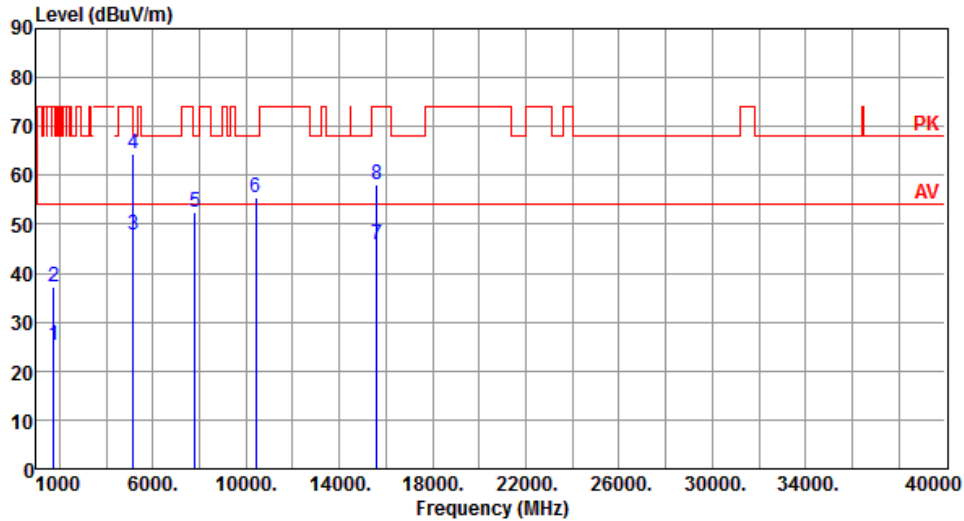

	Freq. MHz	Emission level dBuV/m	Limit dBuV/m	Margin dB	SA reading dBuV	Factor dB	Remark	ANT High cm	Turn Table deg
1	1733.33	25.33	54.00	-28.67	31.49	-6.16	Average	100	49
2	1733.33	37.21	74.00	-36.79	43.37	-6.16	Peak	100	49
3	5150.00	47.70	54.00	-6.30	43.46	4.24	Average	224	216
4	5150.00	64.45	74.00	-9.55	60.21	4.24	Peak	224	216
5	7800.00	52.49	68.20	-15.71	43.32	9.17	Peak	100	150
6	10400.00	55.48	68.20	-12.72	41.77	13.71	Peak	100	50
7	15600.00	45.76	54.00	-8.24	31.11	14.65	Average	100	20
8	15600.00	58.21	74.00	-15.79	43.56	14.65	Peak	100	20

Note 1: Emission Level (dBuV/m) = SA Reading (dBuV/m) + Factor* (dB)

*Factor includes antenna factor , cable loss and amplifier gain

Note 2: Margin (dB) = Emission level (dBuV/m) – Limit (dBuV/m).

Modulation	11a	Test Freq. (MHz)	5200
Polarization	Vertical		

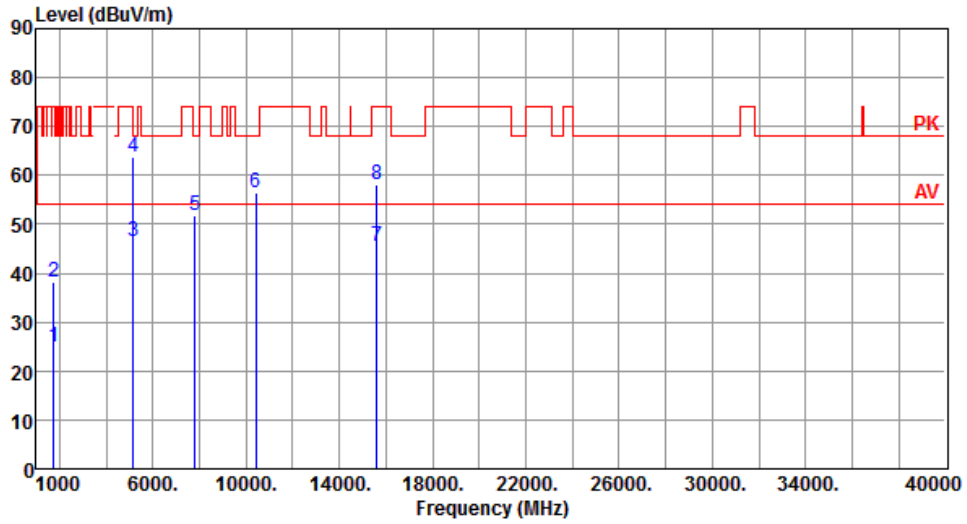

	Freq. MHz	Emission level dBuV/m	Limit dBuV/m	Margin dB	SA reading dBuV	Factor dB	Remark	ANT High cm	Turn Table deg
1	1733.33	25.03	54.00	-28.97	31.19	-6.16	Average	100	4
2	1733.33	38.21	74.00	-35.79	44.37	-6.16	Peak	100	4
3	5150.00	46.51	54.00	-7.49	42.27	4.24	Average	148	81
4	5150.00	63.74	74.00	-10.26	59.50	4.24	Peak	148	81
5	7800.00	51.77	68.20	-16.43	42.60	9.17	Peak	100	50
6	10400.00	56.61	68.20	-11.59	42.90	13.71	Peak	100	272
7	15600.00	45.35	54.00	-8.65	30.70	14.65	Average	100	178
8	15600.00	58.22	74.00	-15.78	43.57	14.65	Peak	100	178

Note 1: Emission Level (dBuV/m) = SA Reading (dBuV/m) + Factor* (dB)

*Factor includes antenna factor , cable loss and amplifier gain

Note 2: Margin (dB) = Emission level (dBuV/m) – Limit (dBuV/m).

Modulation	11a	Test Freq. (MHz)	5240
Polarization	Horizontal		

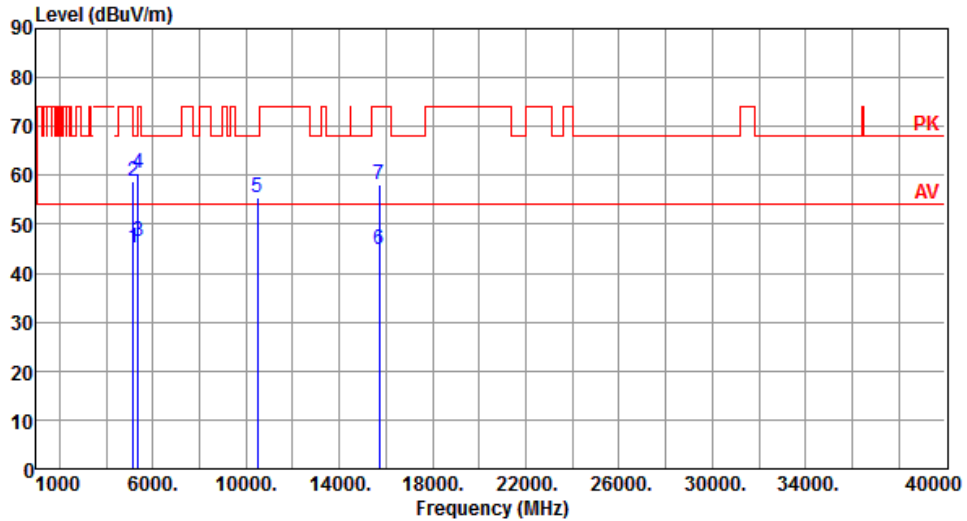

	Freq. MHz	Emission level dBuV/m	Limit dBuV/m	Margin dB	SA reading dBuV	Factor dB	Remark	ANT High cm	Turn Table deg
1	5150.00	45.16	54.00	-8.84	40.92	4.24	Average	215	221
2	5150.00	58.89	74.00	-15.11	54.65	4.24	Peak	215	221
3	5350.00	46.63	54.00	-7.37	42.20	4.43	Average	215	221
4	5350.00	60.51	74.00	-13.49	56.08	4.43	Peak	215	221
5	10480.00	55.31	68.20	-12.89	41.57	13.74	Peak	100	60
6	15720.00	44.87	54.00	-9.13	30.29	14.58	Average	100	70
7	15720.00	58.15	74.00	-15.85	43.57	14.58	Peak	100	70

Note 1: Emission Level (dBuV/m) = SA Reading (dBuV/m) + Factor* (dB)

*Factor includes antenna factor , cable loss and amplifier gain

Note 2: Margin (dB) = Emission level (dBuV/m) – Limit (dBuV/m).

Modulation	11a	Test Freq. (MHz)	5240
Polarization	Vertical		

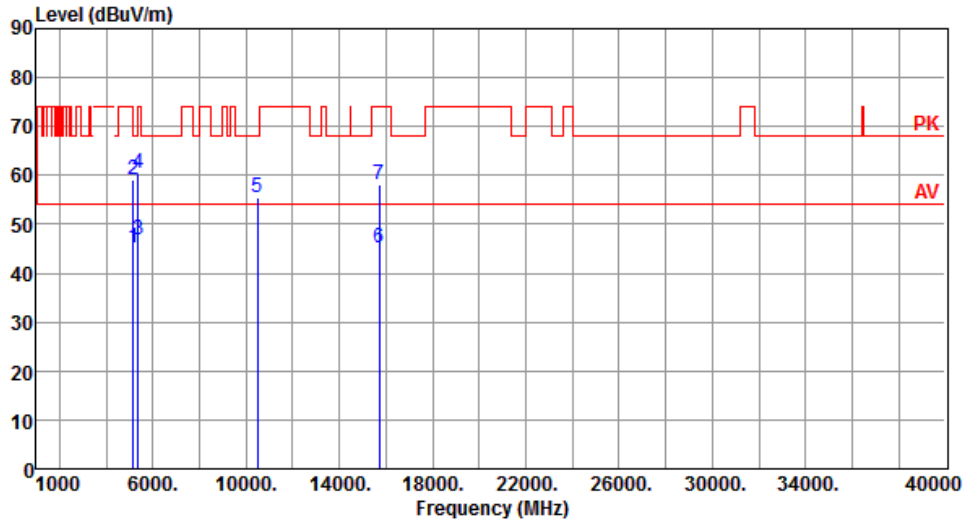

	Freq. MHz	Emission level dBuV/m	Limit dBuV/m	Margin dB	SA reading dBuV	Factor dB	Remark	ANT High cm	Turn Table deg
1	5150.00	45.29	54.00	-8.71	41.05	4.24	Average	105	78
2	5150.00	59.06	74.00	-14.94	54.82	4.24	Peak	105	78
3	5350.00	46.78	54.00	-7.22	42.35	4.43	Average	105	78
4	5350.00	60.53	74.00	-13.47	56.10	4.43	Peak	105	78
5	10480.00	55.43	68.20	-12.77	41.69	13.74	Peak	100	270
6	15720.00	45.04	54.00	-8.96	30.46	14.58	Average	100	50
7	15720.00	58.03	74.00	-15.97	43.45	14.58	Peak	100	50

Note 1: Emission Level (dBuV/m) = SA Reading (dBuV/m) + Factor* (dB)

*Factor includes antenna factor , cable loss and amplifier gain

Note 2: Margin (dB) = Emission level (dBuV/m) – Limit (dBuV/m).

Modulation	11a	Test Freq. (MHz)	5260
Polarization	Horizontal		

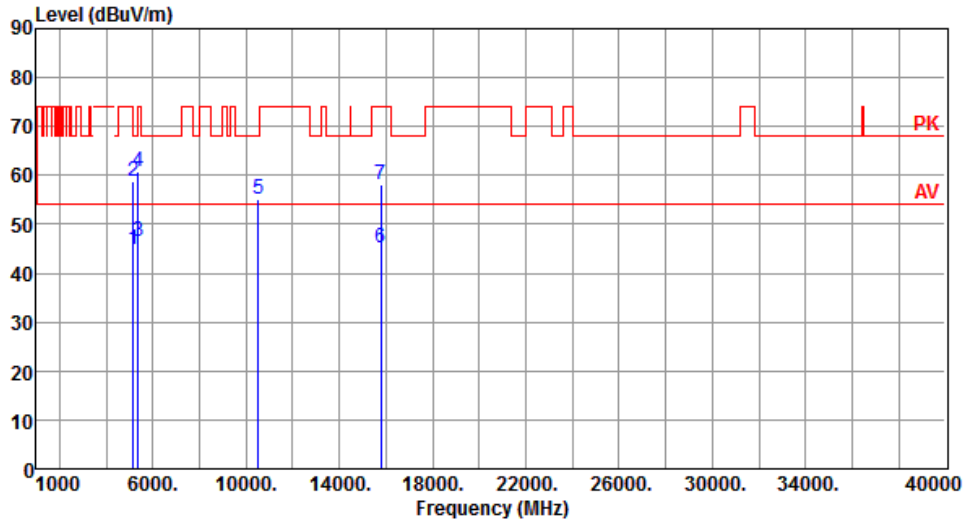

	Freq. MHz	Emission level dBuV/m	Limit dBuV/m	Margin dB	SA reading dBuV	Factor dB	Remark	ANT High cm	Turn Table deg
1	5150.00	44.84	54.00	-9.16	40.60	4.24	Average	225	223
2	5150.00	58.68	74.00	-15.32	54.44	4.24	Peak	225	223
3	5350.00	46.47	54.00	-7.53	42.04	4.43	Average	225	223
4	5350.00	60.69	74.00	-13.31	56.26	4.43	Peak	225	223
5	10520.00	55.22	68.20	-12.98	41.45	13.77	Peak	100	30
6	15780.00	45.02	54.00	-8.98	30.47	14.55	Average	100	50
7	15780.00	58.11	74.00	-15.89	43.56	14.55	Peak	100	50

Note 1: Emission Level (dBuV/m) = SA Reading (dBuV/m) + Factor* (dB)

*Factor includes antenna factor , cable loss and amplifier gain

Note 2: Margin (dB) = Emission level (dBuV/m) – Limit (dBuV/m).

Modulation	11a	Test Freq. (MHz)	5260
Polarization	Vertical		

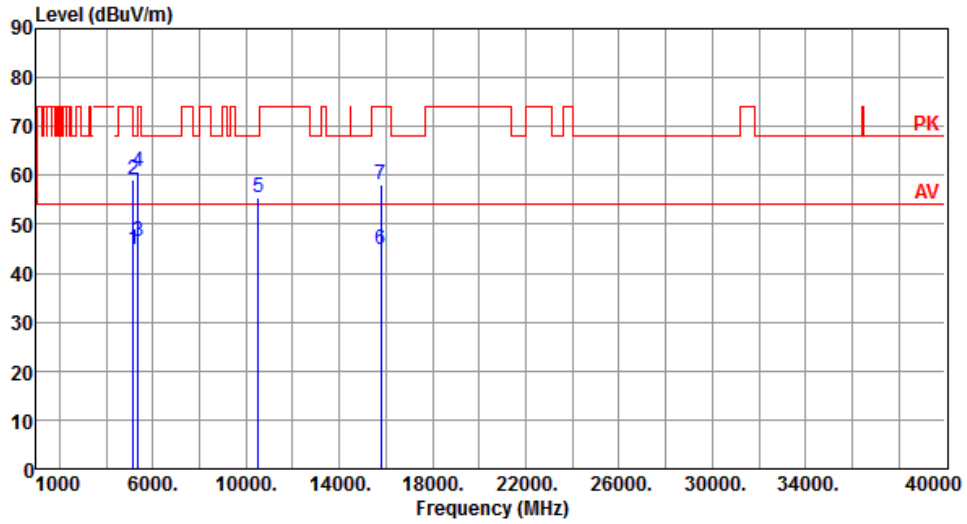

	Freq. MHz	Emission level dBuV/m	Limit dBuV/m	Margin dB	SA reading dBuV	Factor dB	Remark	ANT High cm	Turn Table deg
1	5150.00	44.80	54.00	-9.20	40.56	4.24	Average	101	80
2	5150.00	59.05	74.00	-14.95	54.81	4.24	Peak	101	80
3	5350.00	46.63	54.00	-7.37	42.20	4.43	Average	101	80
4	5350.00	60.81	74.00	-13.19	56.38	4.43	Peak	101	80
5	10520.00	55.34	68.20	-12.86	41.57	13.77	Peak	100	70
6	15780.00	44.82	54.00	-9.18	30.27	14.55	Average	100	60
7	15780.00	57.96	74.00	-16.04	43.41	14.55	Peak	100	60

Note 1: Emission Level (dBuV/m) = SA Reading (dBuV/m) + Factor* (dB)

*Factor includes antenna factor , cable loss and amplifier gain

Note 2: Margin (dB) = Emission level (dBuV/m) – Limit (dBuV/m).

Modulation	11a	Test Freq. (MHz)	5300
Polarization	Horizontal		

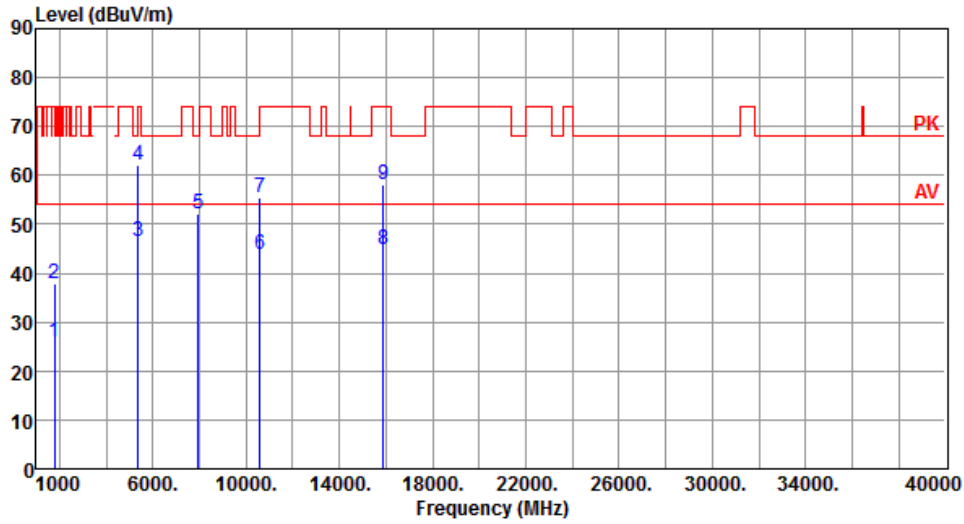

	Freq. MHz	Emission level dBuV/m	Limit dBuV/m	Margin dB	SA reading dBuV	Factor dB	Remark	ANT High cm	Turn Table deg
1	1766.66	25.85	54.00	-28.15	31.88	-6.03	Average	100	26
2	1766.66	37.82	74.00	-36.18	43.85	-6.03	Peak	100	26
3	5350.00	46.65	54.00	-7.35	42.22	4.43	Average	218	223
4	5350.00	62.01	74.00	-11.99	57.58	4.43	Peak	218	223
5	7950.00	52.10	68.20	-16.10	42.58	9.52	Peak	100	80
6	10600.00	43.74	54.00	-10.26	29.87	13.87	Average	100	60
7	10600.00	55.46	74.00	-18.54	41.59	13.87	Peak	100	60
8	15900.00	44.94	54.00	-9.06	30.46	14.48	Average	100	30
9	15900.00	58.06	74.00	-15.94	43.58	14.48	Peak	100	30

Note 1: Emission Level (dBuV/m) = SA Reading (dBuV/m) + Factor* (dB)

*Factor includes antenna factor , cable loss and amplifier gain

Note 2: Margin (dB) = Emission level (dBuV/m) – Limit (dBuV/m).

Modulation	11a	Test Freq. (MHz)	5300
Polarization	Vertical		

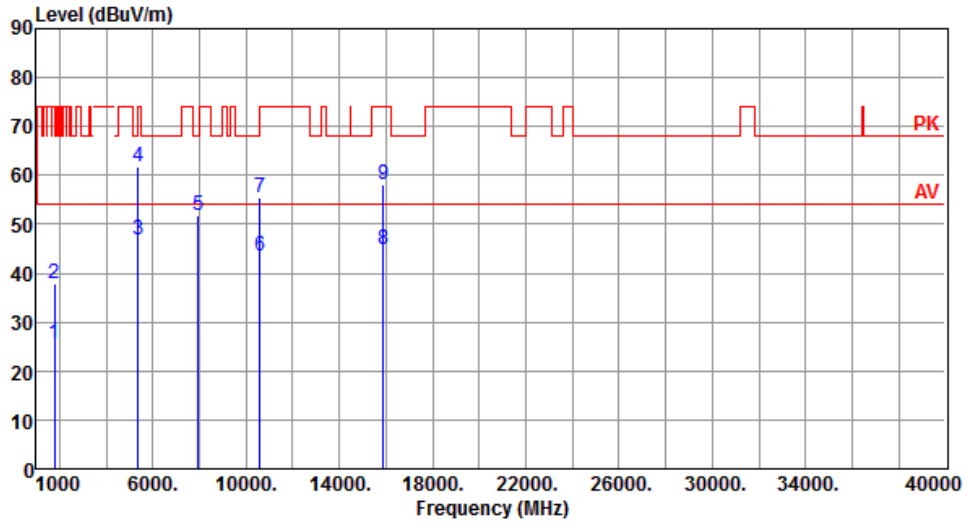

	Freq. MHz	Emission level dBuV/m	Limit dBuV/m	Margin dB	SA reading dBuV	Factor dB	Remark	ANT High cm	Turn Table deg
1	1766.66	25.49	54.00	-28.51	31.52	-6.03	Average	100	2
2	1766.66	37.82	74.00	-36.18	43.85	-6.03	Peak	100	2
3	5350.00	46.92	54.00	-7.08	42.49	4.43	Average	123	80
4	5350.00	61.76	74.00	-12.24	57.33	4.43	Peak	123	80
5	7950.00	51.81	68.20	-16.39	42.29	9.52	Peak	100	50
6	10600.00	43.45	54.00	-10.55	29.58	13.87	Average	100	70
7	10600.00	55.35	74.00	-18.65	41.48	13.87	Peak	100	70
8	15900.00	44.95	54.00	-9.05	30.47	14.48	Average	100	20
9	15900.00	58.17	74.00	-15.83	43.69	14.48	Peak	100	20

Note 1: Emission Level (dBuV/m) = SA Reading (dBuV/m) + Factor* (dB)

*Factor includes antenna factor , cable loss and amplifier gain

Note 2: Margin (dB) = Emission level (dBuV/m) – Limit (dBuV/m).

Modulation	11a	Test Freq. (MHz)	5320
Polarization	Horizontal		

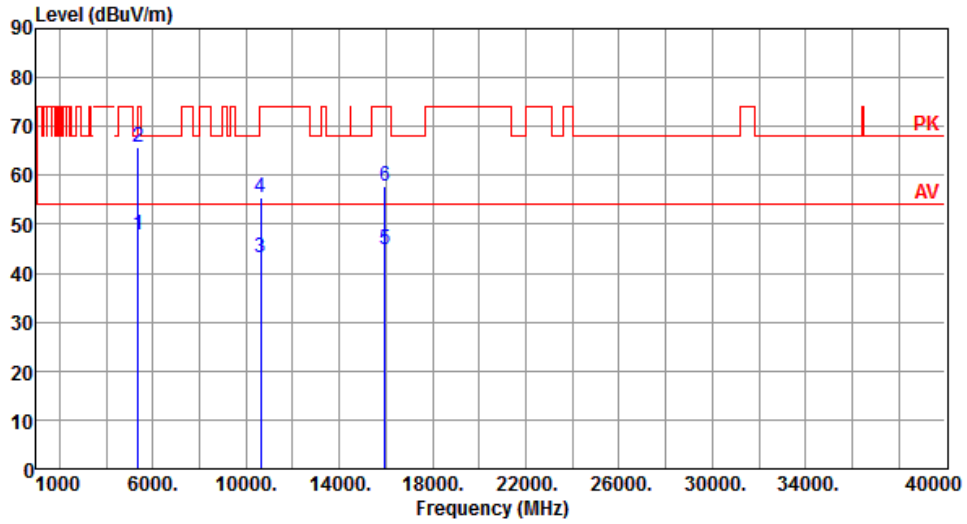

	Freq. MHz	Emission level dBuV/m	Limit dBuV/m	Margin dB	SA reading dBuV	Factor dB	Remark	ANT High cm	Turn Table deg
1	5350.00	47.69	54.00	-6.31	43.26	4.43	Average	214	219
2	5350.00	65.75	74.00	-8.25	61.32	4.43	Peak	214	219
3	10640.00	43.16	54.00	-10.84	29.24	13.92	Average	100	200
4	10640.00	55.49	74.00	-18.51	41.57	13.92	Peak	100	200
5	15960.00	44.86	54.00	-9.14	30.42	14.44	Average	100	100
6	15960.00	57.91	74.00	-16.09	43.47	14.44	Peak	100	100

Note 1: Emission Level (dBuV/m) = SA Reading (dBuV/m) + Factor* (dB)

*Factor includes antenna factor , cable loss and amplifier gain

Note 2: Margin (dB) = Emission level (dBuV/m) – Limit (dBuV/m).

Modulation	11a	Test Freq. (MHz)	5320
Polarization	Vertical		

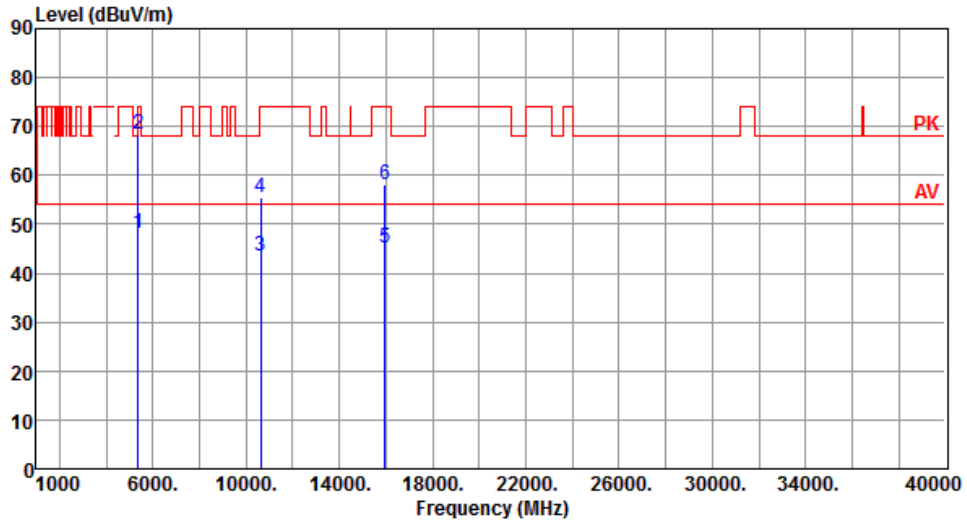

	Freq. MHz	Emission level dBuV/m	Limit dBuV/m	Margin dB	SA reading dBuV	Factor dB	Remark	ANT High cm	Turn Table deg
1	5350.00	48.01	54.00	-5.99	43.58	4.43	Average	100	79
2	5350.00	68.39	74.00	-5.61	63.96	4.43	Peak	100	79
3	10640.00	43.37	54.00	-10.63	29.45	13.92	Average	100	50
4	10640.00	55.44	74.00	-18.56	41.52	13.92	Peak	100	50
5	15960.00	45.00	54.00	-9.00	30.56	14.44	Average	100	40
6	15960.00	57.95	74.00	-16.05	43.51	14.44	Peak	100	40

Note 1: Emission Level (dBuV/m) = SA Reading (dBuV/m) + Factor* (dB)

*Factor includes antenna factor , cable loss and amplifier gain

Note 2: Margin (dB) = Emission level (dBuV/m) – Limit (dBuV/m).

Modulation	11a	Test Freq. (MHz)	5500
Polarization	Horizontal		

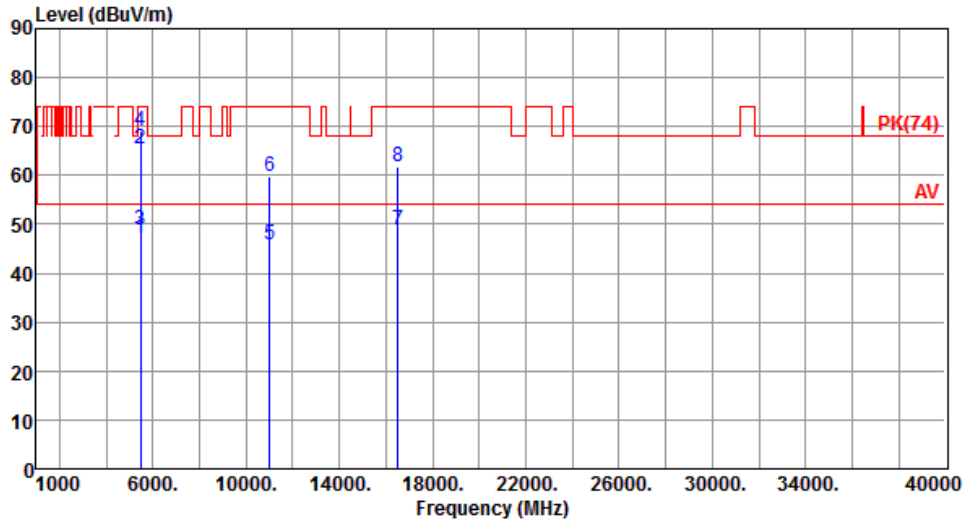

	Freq. MHz	Emission level dBuV/m	Limit dBuV/m	Margin dB	SA reading dBuV	Factor dB	Remark	ANT High cm	Turn Table deg
1	5460.00	47.18	54.00	-6.82	42.67	4.51	Average	204	310
2	5460.00	65.40	74.00	-8.60	60.89	4.51	Peak	204	310
3	5470.00	48.91	54.00	-5.09	44.39	4.52	Average	204	310
4	5470.00	68.99	74.00	-5.01	64.47	4.52	Peak	204	310
5	11000.00	45.99	54.00	-8.01	31.65	14.34	Average	204	295
6	11000.00	59.73	74.00	-14.27	45.39	14.34	Peak	204	295
7	16500.00	48.93	54.00	-5.07	32.45	16.48	Average	149	326
8	16500.00	61.71	74.00	-12.29	45.23	16.48	Peak	149	326

Note 1: Emission Level (dBuV/m) = SA Reading (dBuV/m) + Factor* (dB)

*Factor includes antenna factor , cable loss and amplifier gain

Note 2: Margin (dB) = Emission level (dBuV/m) – Limit (dBuV/m).

Modulation	11a	Test Freq. (MHz)	5500
Polarization	Vertical		

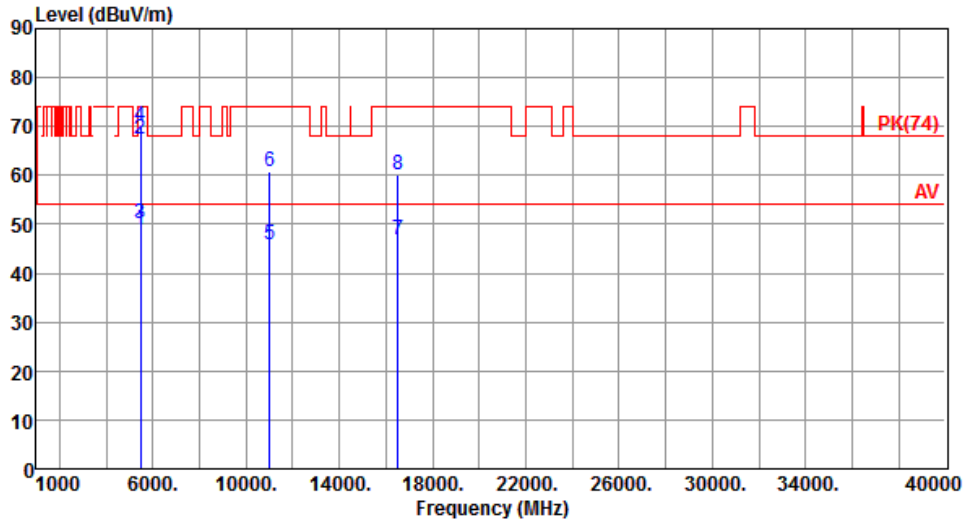

	Freq. MHz	Emission level dBuV/m	Limit dBuV/m	Margin dB	SA reading dBuV	Factor dB	Remark	ANT High cm	Turn Table deg
1	5460.00	48.90	54.00	-5.10	44.39	4.51	Average	209	107
2	5460.00	67.45	74.00	-6.55	62.94	4.51	Peak	209	107
3	5470.00	50.20	54.00	-3.80	45.68	4.52	Average	209	107
4	5470.00	70.04	74.00	-3.96	65.52	4.52	Peak	209	107
5	11000.00	45.83	54.00	-8.17	31.49	14.34	Average	100	256
6	11000.00	60.90	74.00	-13.10	46.56	14.34	Peak	100	256
7	16500.00	46.83	54.00	-7.17	30.35	16.48	Average	100	235
8	16500.00	60.06	74.00	-13.94	43.58	16.48	Peak	100	235

Note 1: Emission Level (dBuV/m) = SA Reading (dBuV/m) + Factor* (dB)

*Factor includes antenna factor , cable loss and amplifier gain

Note 2: Margin (dB) = Emission level (dBuV/m) – Limit (dBuV/m).

Modulation	11a	Test Freq. (MHz)	5580
Polarization	Horizontal		

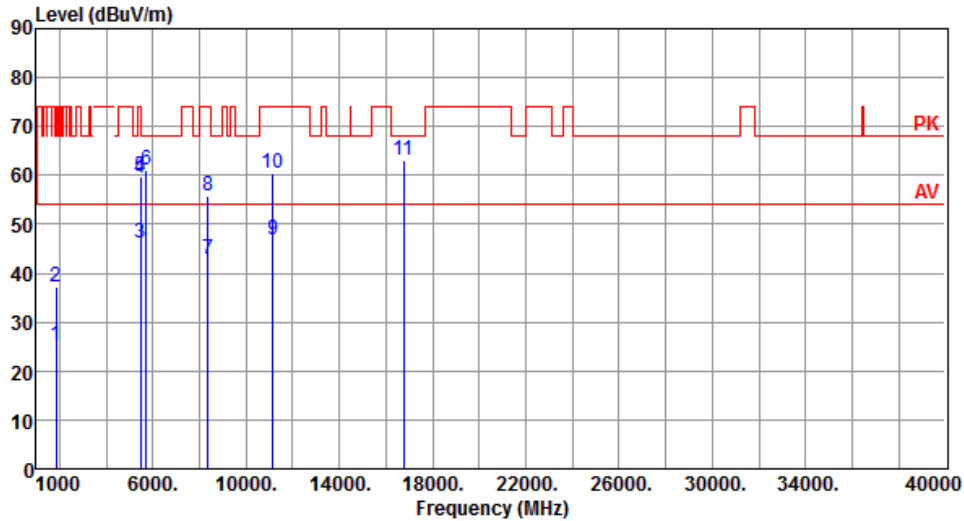

	Freq. MHz	Emission level dBuV/m	Limit dBuV/m	Margin dB	SA reading dBuV	Factor dB	Remark	ANT High cm	Turn Table deg
1	1860.00	25.37	54.00	-28.63	31.08	-5.71	Average	100	355
2	1860.00	37.31	74.00	-36.69	43.02	-5.71	Peak	100	355
3	5460.00	46.12	54.00	-7.88	41.61	4.51	Average	194	206
4	5460.00	59.51	74.00	-14.49	55.00	4.51	Peak	194	206
5	5470.00	59.67	68.20	-8.53	55.15	4.52	Peak	194	206
6	5725.00	61.03	68.20	-7.17	56.21	4.82	Peak	194	206
7	8370.00	42.85	54.00	-11.15	33.30	9.55	Average	162	243
8	8370.00	55.72	74.00	-18.28	46.17	9.55	Peak	162	243
9	11160.00	46.90	54.00	-7.10	32.70	14.20	Average	197	293
10	11160.00	60.47	74.00	-13.53	46.27	14.20	Peak	197	293
11	16740.00	63.02	68.20	-5.18	46.10	16.92	Peak	151	322

Note 1: Emission Level (dBuV/m) = SA Reading (dBuV/m) + Factor* (dB)

*Factor includes antenna factor , cable loss and amplifier gain

Note 2: Margin (dB) = Emission level (dBuV/m) – Limit (dBuV/m).

Modulation	11a	Test Freq. (MHz)	5580
Polarization	Vertical		

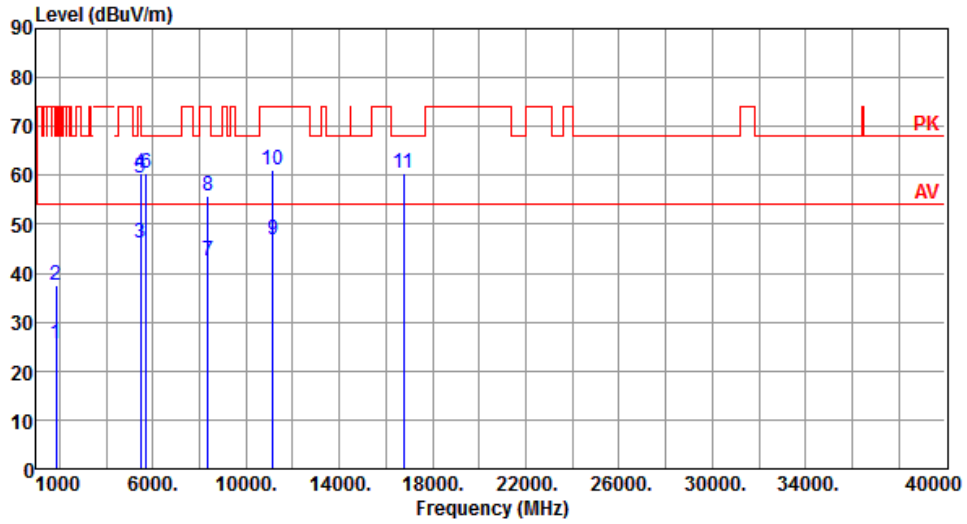

	Freq. MHz	Emission level dBuV/m	Limit dBuV/m	Margin dB	SA reading dBuV	Factor dB	Remark	ANT High cm	Turn Table deg
1	1860.00	25.73	54.00	-28.27	31.44	-5.71	Average	100	9
2	1860.00	37.37	74.00	-36.63	43.08	-5.71	Peak	100	9
3	5460.00	46.20	54.00	-7.80	41.69	4.51	Average	355	106
4	5460.00	60.57	74.00	-13.43	56.06	4.51	Peak	355	106
5	5470.00	59.61	68.20	-8.59	55.09	4.52	Peak	355	106
6	5725.00	60.40	68.20	-7.80	55.58	4.82	Peak	355	106
7	8370.00	42.62	54.00	-11.38	33.07	9.55	Average	201	343
8	8370.00	55.94	74.00	-18.06	46.39	9.55	Peak	201	343
9	11160.00	46.74	54.00	-7.26	32.54	14.20	Average	100	258
10	11160.00	61.21	74.00	-12.79	47.01	14.20	Peak	100	258
11	16740.00	60.56	68.20	-7.64	43.64	16.92	Peak	100	234

Note 1: Emission Level (dBuV/m) = SA Reading (dBuV/m) + Factor* (dB)

*Factor includes antenna factor , cable loss and amplifier gain

Note 2: Margin (dB) = Emission level (dBuV/m) – Limit (dBuV/m).