

# FCC Test Report

**FCC ID** : SQG-SONAIF573  
**Equipment** : Sona IF573 802.11ax Wi-Fi 6E Module with Bluetooth 5.4  
**Model No.** : Sona IF573  
**Brand Name** : Laird Connectivity  
**Applicant** : Laird Connectivity LLC  
**Address** : W66N220 Commerce Court, Cedarburg, WI 53012 United States Of America  
**Standard** : 47 CFR FCC Part 15.247  
**Received Date** : Jan. 17, 2023  
**Tested Date** : Apr. 07 ~ May 23, 2023

We, International Certification Corporation, would like to declare that the tested sample has been evaluated and in compliance with the requirement of the above standards. The test results contained in this report refer exclusively to the product. It shall not be reproduced except in full without the written approval of our laboratory.

Reviewed by:

Approved by:

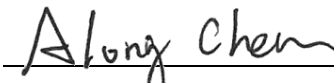
  
\_\_\_\_\_  
Along Chen / Assistant Manager

  
\_\_\_\_\_  
Gary Chang / Manager

## Table of Contents

<b>1</b>	<b>GENERAL DESCRIPTION .....</b>	<b>5</b>
1.1	Information.....	5
1.2	Local Support Equipment List .....	8
1.3	Test Setup Chart .....	8
1.4	The Equipment List .....	10
1.5	Test Standards .....	11
1.6	Reference Guidance .....	11
1.7	Deviation from Test Standard and Measurement Procedure.....	11
1.8	Measurement Uncertainty .....	11
<b>2</b>	<b>TEST CONFIGURATION.....</b>	<b>12</b>
2.1	Testing Facility .....	12
2.2	The Worst Test Modes and Channel Details .....	13
2.3	Directional gain.....	14
<b>3</b>	<b>TRANSMITTER TEST RESULTS .....</b>	<b>15</b>
3.1	6dB and Occupied Bandwidth.....	15
3.2	Conducted Output Power .....	16
3.3	Power Spectral Density .....	17
3.4	Unwanted Emissions into Restricted Frequency Bands .....	18
3.5	Emissions in Non-Restricted Frequency Bands.....	20
3.6	AC Power Line Conducted Emissions .....	21
<b>4</b>	<b>TEST LABORATORY INFORMATION .....</b>	<b>22</b>

**Appendix A. 6dB and Occupied Bandwidth**

**Appendix B. Conducted Output Power**

**Appendix C. Power Spectral Density**

**Appendix D. Unwanted Emissions into Restricted Frequency Bands**

**Appendix E. Emissions in Non-Restricted Frequency Bands**

**Appendix F. AC Power Line Conducted Emissions**

---

## Release Record

Report No.	Version	Description	Issued Date
FR311701AC	Rev. 01	Initial issue	Jul. 28, 2023

## Summary of Test Results

FCC Rules	Test Items	Measured	Result
15.207	AC Power Line Conducted Emission	[dBuV]: 0.500MHz 39.23 (Margin -6.77dB) - AV	Pass
15.247(d) 15.209	Unwanted Emissions	[dBuV/m at 3m]: 4000.00MHz 50.99 (Margin -3.01dB) - AV	Pass
15.247(b)(3)	Conducted Output Power	Max Power [dBm]: <i>Non-beamforming mode</i> 27.66 <i>Beamforming mode</i> 24.65	Pass
15.247(a)(2)	6dB Bandwidth	Meet the requirement of limit	Pass
15.247(e)	Power Spectral Density	Meet the requirement of limit	Pass
15.203	Antenna Requirement	Meet the requirement of limit	Pass

### Declaration of Conformity:

The test results with all measurement uncertainty excluded are presented in accordance with the regulation limits or requirements declared by manufacturers.

### Comments and Explanations:

The declared of product specification for EUT presented in the report are provided by the manufacturer, and the manufacturer takes all the responsibilities for the accuracy of product specification.

# 1 General Description

## 1.1 Information

### 1.1.1 Product Details

The four configurations of the EUT are shown on the following:

Model Name	Part No.	Description
Sona IF573	453-00117	Module, Sona IF573, MIMO, MHF4
	453-00118	Module, Sona IF573, MIMO, Trace Pin
	453-00119	Module, Sona IF573, MIMO, M.2, Key E, SDIO, UART
	453-00120	Module, Sona IF573, MIMO, M.2, Key E, PCIe, UART

### 1.1.2 Specification of the Equipment under Test (EUT)

RF General Information					
Frequency Range (MHz)	IEEE Std. 802.11	Ch. Freq. (MHz)	Channel Number	Transmit Chains (N <sub>TX</sub> )	Data Rate / MCS
2400-2483.5	b	2412-2462	1-11 [11]	2	1-11 Mbps
2400-2483.5	g	2412-2462	1-11 [11]	2	6-54 Mbps
2400-2483.5	n (HT20)	2412-2462	1-11 [11]	2	MCS 0-15
2400-2483.5	ax (HE20)	2412-2462	1-11 [11]	2	MCS 0-11

Note 1: RF output power specifies that Maximum Peak Conducted Output Power.  
 Note 2: DSSS-DBPSK, DQPSK, CCK modulation  
 OFDM/OFDMA- BPSK, QPSK, 16QAM, 64QAM, 256QAM and 1024QAM modulation.  
 Note 3: 802.11ax supports beamforming function.  
 Note 4: 802.11ax supports full RU and partial RU configuration. Test results of full RU configuration are recorded in this report. Refers to report no.: FR311701-1AC for test results of partial RU configuration.

### 1.1.3 Antenna Details

Ant. No.	Manufacturer	Model	Part Number	Type	Connector	Operating Frequencies / Gain (dBi)		
						2.4GHz	5GHz	6GHz
1	JOYMAX	TWX-100B RSAX-2001	NA	Dipole	RP-SMA	2	4	4
2	Laird	FlexMIMO 6E	EFD2471A3 S-10MH4L	PIFA	MHF4L	2.2	3.8	3.3
3	Laird	Mini NanoBlade Flex 6 GHz	EMF2471A 3S-10MH4L	PCB Dipole	MHF4L	2.4	4.4	5.2
4	Laird	FlexPIFA 6E	EFD2471A3 S-10MH4L	PIFA	MHF4L	2.2	3.9	3.8

#### 1.1.4 Power Supply Type of Equipment under Test (EUT)

<b>Power Supply Type</b>	3.3Vdc from host
--------------------------	------------------

#### 1.1.5 Accessories

N/A

#### 1.1.6 Channel List

Channel	Frequency(MHz)
1	2412
2	2417
3	2422
4	2427
5	2432
6	2437
7	2442
8	2447
9	2452
10	2457
11	2462

#### 1.1.7 Test Tool and Duty Cycle

<b>Test Tool</b>	Tera Term, V4.49		
<b>Duty Cycle and Duty Factor</b>	<b>Mode</b>	<b>Duty Cycle (%)</b>	<b>Duty Factor (dB)</b>
	11b	99.86%	0.01
	11g	99.45%	0.02
	ax HE20-OFDMA	99.55%	0.02

## 1.1.8 Power Index of Test Tool

### SC Module

Modulation Mode	Test Frequency (MHz)	Power Index
11b	2412	56
11b	2437	70
11b	2462	52
11g	2412	54
11g	2437	64
11g	2462	48
ax HE20-OFDMA	2412	39
ax HE20-OFDMA	2437	30
ax HE20-OFDMA	2462	41

### ST M.2, PCIe module

Modulation Mode	Test Frequency (MHz)	Power Index
11b	2412	60
11b	2437	72
11b	2462	52
11g	2412	54
11g	2437	66
11g	2462	48
ax HE20-OFDMA	2412	38
ax HE20-OFDMA	2437	28
ax HE20-OFDMA	2462	40

## 1.2 Local Support Equipment List

Support Equipment List					
No.	Equipment	Brand	Model	FCC ID	Remarks
1	Laptop	DELL	Latitude 5400	DoC	---
2	Fixture	---	700-46370 REV B	---	Provided by applicant.
3	Fixture's adapter	---	EA1045CR	---	Provided by applicant. I/P: 100-240Vac,1.5A,50-60Hz O/P: 5.0V 3.0A
4	50Ω terminator	---	---	---	---

## 1.3 Test Setup Chart

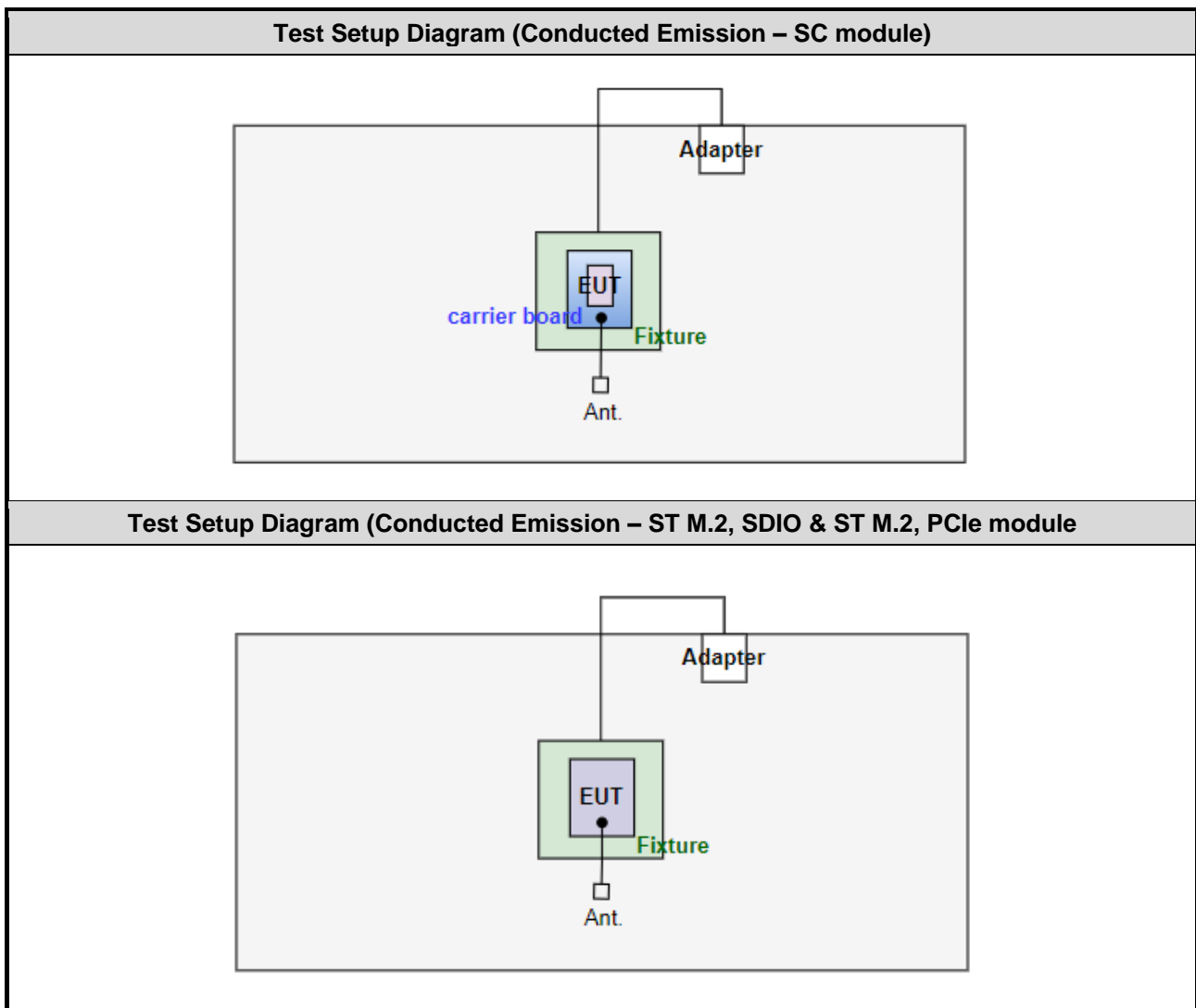



**Test Setup Diagram (Radiated Emission – SC module)**

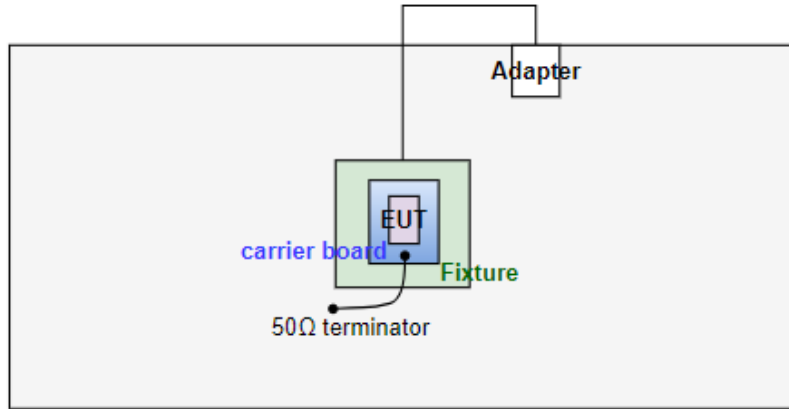

**Test Setup Diagram (Radiated Emission – ST M.2, SDIO & ST M.2, PCIe module)**

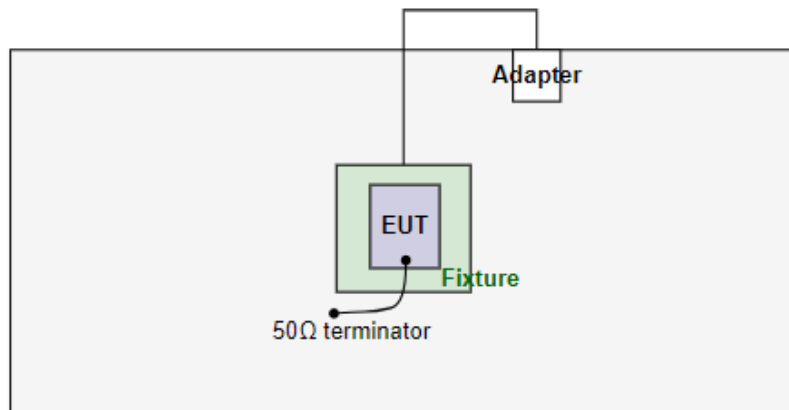

## 1.4 The Equipment List

<b>Test Item</b>	Conducted Emission				
<b>Test Site</b>	Conduction room 1 / (CO01-WS)				
<b>Tested Date</b>	May 23, 2023				
<b>Instrument</b>	<b>Brand</b>	<b>Model No.</b>	<b>Serial No.</b>	<b>Calibration Date</b>	<b>Calibration Until</b>
Receiver	R&S	ESR3	101658	Feb. 17, 2023	Feb. 16, 2024
LISN	R&S	ENV216	101295	Jan. 31, 2023	Jan. 30, 2024
LISN (Support Unit)	SCHWARZBECK	Schwarzbeck 8127	8127667	Jan. 03, 2023	Jan. 02, 2024
RF Cable-CON	Woken	CFD200-NL	CFD200-NL-001	Oct. 17, 2022	Oct. 16, 2023
50 ohm terminal (Support Unit)	NA	50	03	Jun. 08, 2022	Jun. 07, 2023
Measurement S/W	AUDIX	e3	6.120210k	NA	NA
Measurement S/W	Sporton	SENSE-EMI	V5.10.8.7	NA	NA
Note: Calibration Interval of instruments listed above is one year.					

<b>Test Item</b>	Radiated Emission				
<b>Test Site</b>	966 chamber1 / (03CH01-WS)				
<b>Tested Date</b>	Apr. 12 ~ Apr. 27, 2023				
<b>Instrument</b>	<b>Brand</b>	<b>Model No.</b>	<b>Serial No.</b>	<b>Calibration Date</b>	<b>Calibration Until</b>
Receiver	R&S	ESR3	101657	Mar. 03, 2023	Mar. 02, 2024
Spectrum Analyzer	R&S	FSV40	101498	Nov. 21, 2022	Nov. 20, 2023
Loop Antenna	R&S	HFH2-Z2	100330	Nov. 01, 2022	Oct. 31, 2023
Bilog Antenna	SCHWARZBECK	VULB9168	VULB9168-522	Aug. 03, 2022	Aug. 02, 2023
Horn Antenna 1G-18G	SCHWARZBECK	BBHA 9120 D	BBHA 9120 D 1096	Nov. 25, 2022	Nov. 24, 2023
Horn Antenna 18G-40G	SCHWARZBECK	BBHA 9170	BBHA 9170517	Oct. 27, 2022	Oct. 26, 2023
Preamplifier	EMC	EMC02325	980225	Jun. 28, 2022	Jun. 27, 2023
Preamplifier	EMC	EMC118A45SE	980898	Jul. 16, 2022	Jul. 15, 2023
Preamplifier	EMC	EMC184045SE	980903	Jul. 16, 2022	Jul. 15, 2023
Loop Antenna Cable	KOAX KABEL	101354-BW	101354-BW	Oct. 04, 2022	Oct. 03, 2023
LF cable 3M	Woken	CFD400NL-LW	CFD400NL-001	Oct. 04, 2022	Oct. 03, 2023
LF cable 11M	EMC	EMCCFD400-NW-NW-11000	200801	Oct. 04, 2022	Oct. 03, 2023
LF cable 1M	EMC	EMCCFD400-NM-NM-1000	160502	Oct. 04, 2022	Oct. 03, 2023
RF Cable	EMC	EMC104-35M-35M-8000	210920	Oct. 04, 2022	Oct. 03, 2023
RF Cable	EMC	EMC104-35M-35M-3000	210922	Oct. 04, 2022	Oct. 03, 2023
HIGHPASS FILTER 3.1-18G	WHK	WHK3.1/18G-10SS	39	Oct. 06, 2022	Oct. 05, 2023
Attenuator	woken	PE7013-10	10-1	Oct. 14, 2022	Oct. 13, 2023
Measurement S/W	AUDIX	e3	6.120210g	NA	NA
Note: Calibration Interval of instruments listed above is one year.					

<b>Test Item</b>	RF Conducted				
<b>Test Site</b>	(TH01-WS)				
<b>Tested Date</b>	Apr. 07 ~ May 17, 2023				
<b>Instrument</b>	<b>Brand</b>	<b>Model No.</b>	<b>Serial No.</b>	<b>Calibration Date</b>	<b>Calibration Until</b>
Spectrum Analyzer	R&S	FSV40	101498	Nov. 21, 2022	Nov. 20, 2023
Power Meter	Anritsu	ML2495A	1241002	Nov. 23, 2022	Nov. 22, 2023
Power Sensor	Anritsu	MA2411B	1207366	Nov. 23, 2022	Nov. 22, 2023
HIGHPASS FILTER 3.1-18G	WHK	WHK3.1/18G-10SS	39	Oct. 06, 2022	Oct. 05, 2023
LOWPASS FILTER	WI	WLKS1100-12SS	2	Oct. 06, 2022	Oct. 05, 2023
Attenuator	woken	PE7013-10	10-1	Oct. 14, 2022	Oct. 13, 2023
Measurement S/W	Sporton	SENSE-15247_DTS	V5.11	NA	NA
Note: Calibration Interval of instruments listed above is one year.					

## 1.5 Test Standards

47 CFR FCC Part 15.247

ANSI C63.10-2013

## 1.6 Reference Guidance

FCC KDB 558074 D01 15.247 Meas Guidance v05r02

FCC KDB 662911 D01 Multiple Transmitter Output v02r01

## 1.7 Deviation from Test Standard and Measurement Procedure

None

## 1.8 Measurement Uncertainty

The measurement uncertainties given below are based on a 95% confidence level (based on a coverage factor ( $k=2$ )).

Measurement Uncertainty	
Parameters	Uncertainty
Bandwidth	±34.130 Hz
Conducted power	±0.808 dB
Power density	±0.583 dB
Conducted emission	±2.715 dB
AC conducted emission	±2.92 dB
Unwanted Emission ≤ 1GHz	±3.41 dB
Unwanted Emission > 1GHz	±4.59 dB

---

## 2 Test Configuration

### 2.1 Testing Facility

<b>Test Laboratory</b>	International Certification Corporation
<b>Test Site</b>	CO01-WS, 03CH01-WS, TH01-WS
<b>Address of Test Site</b>	No.3-1, Lane 6, Wen San 3rd St., Kwei Shan Dist., Tao Yuan City 33381, Taiwan (R.O.C.)

- FCC Designation No.: TW2732
- FCC site registration No.: 181692
- ISED#: 10807A
- CAB identifier: TW2732

## 2.2 The Worst Test Modes and Channel Details

Test item	Modulation Mode	Test Frequency (MHz)	Data Rate	Test method	Mode	Test Configuration	Note
<b>Non-beamforming mode</b>							
AC Power Line Conducted Emission	11b	2437	1 Mbps	Conducted	TX	1, 2, 3	Note 2
Unwanted Emissions ≤ 1GHz	11b	2437	1 Mbps	Radiated	TX	1, 2, 3	Note 2
Unwanted Emissions >1GHz	11b 11g ax HE20-OFDMA	2412 / 2437 / 2462 2412 / 2437 / 2462 2412 / 2437 / 2462	1 Mbps 6 Mbps MCS 0	Radiated	TX	1	Note 2
	11b	2437	1 Mbps	Radiated	TX	3	-
Unwanted Emissions ≤ 1GHz	ax HE20-OFDMA	2437	MCS 0	Conducted	TX	1, 3	-
Unwanted Emissions >1GHz	11b 11g ax HE20-OFDMA	2412 / 2437 / 2462 2412 / 2437 / 2462 2412 / 2437 / 2462	1 Mbps 6 Mbps MCS 0	Conducted	TX	1	-
	11b	2412	1 Mbps	Conducted	TX	3	-
Conducted Output Power	11b 11g ax HE20-OFDMA	2412 / 2437 / 2462 2412 / 2437 / 2462 2412 / 2437 / 2462	1 Mbps 6 Mbps MCS 0	Conducted	TX	1, 3	-
6dB bandwidth Power spectral density	11b 11g ax HE20-OFDMA	2412 / 2437 / 2462 2412 / 2437 / 2462 2412 / 2437 / 2462	1 Mbps 6 Mbps MCS 0	Conducted	TX	1	-
<b>Beamforming mode</b>							
Conducted Output Power	ax HE20-OFDMA	2412 / 2437 / 2462	MCS 0	Conducted	TX	1, 3	-
<b>NOTE:</b>							
<ol style="list-style-type: none"> <li>The EUT was pretested with 3 orientations placed on the table for the radiated emission measurement – X, Y, and Z-plane. The <b>Y-plane</b> result was found as the worst case and was shown in this report.</li> <li>The 50Ω terminator is connected to antenna port of EUT for radiated emission measurement.</li> <li>Beamforming mode is calculated not measured. The calculation method is conducted power of non-beamforming – 3.01 dB.</li> <li>Test configurations are listed as below:            Configuration 1: Laird part number: 453-00117 (SC module)            Configuration 2: Laird part number: 453-00119 (ST M.2, SDIO Module)            Configuration 3: Laird part number: 453-00120 (ST M.2, PCIe Module)</li> </ol>							

## 2.3 Directional gain

Directional gain is calculated by following formula from FCC KDB 662911 D01 section F)2)f)(i)

Directional gain =  $G_{ANT}$  + Array Gain; ( $G_{ANT}$  is 2.4 dBi)

For Power measurement (Non-Beamforming)

Array gain = 0 dB for  $N_{ANT} \leq 4$ ; ( $N_{ANT}$  for the device is 2)

For Power spectral density / out of band emission (conducted measurement) / Power measurement (Beamforming)

Array gain =  $10 \cdot \log(N_{ANT}/N_{SS})$  dB; ( $N_{SS}$  for the device is 1)

Directional gain is calculated as below

Test item	$G_{ANT}$ (dBi)	Array gain (dB)	Directional gain (dBi)
Output power (Non-Beamforming)	2.4	0	2.4
Output power (Beamforming)	2.4	3.01	5.41
Power spectral density	2.4	3.01	5.41
Out of band emission(conducted measurement)	2.4	3.01	5.41

### 3 Transmitter Test Results

#### 3.1 6dB and Occupied Bandwidth

##### 3.1.1 Limit of 6dB Bandwidth

The minimum 6dB bandwidth shall be at least 500 kHz.

##### 3.1.2 Test Procedures

###### 6dB Bandwidth

1. Set resolution bandwidth (RBW) = 100 kHz, Video bandwidth = 300 kHz.
2. Detector = Peak, Trace mode = max hold.
3. Sweep = auto couple, Allow the trace to stabilize.
4. Measure the maximum width of the emission that is constrained by the frequencies associated with the two outermost amplitude points (upper and lower) that are attenuated by 6dB relative to the maximum level measured in the fundamental emission.

###### Occupied Bandwidth

1. Set resolution bandwidth (RBW) = 1% ~ 5 % of OBW, Video bandwidth = 3 x RBW
2. Detector = Sample, Trace mode = max hold.
3. Sweep = auto couple, Allow the trace to stabilize.
4. Use the OBW measurement function of spectrum analyzer to measure the occupied bandwidth.

##### 3.1.3 Test Setup

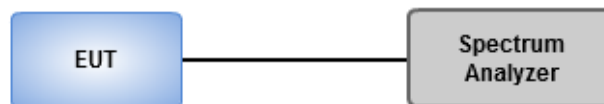

##### 3.1.4 Test Results

<b>Ambient Condition</b>	20-26°C / 61-67%	<b>Tested By</b>	Aska Huang
--------------------------	------------------	------------------	------------

Refer to Appendix A.

## 3.2 Conducted Output Power

### 3.2.1 Limit of Conducted Output Power

Conducted power shall not exceed 1Watt.

Antenna gain  $\leq 6\text{dBi}$ , no any corresponding reduction is in output power limit.

Antenna gain  $> 6\text{dBi}$

Non Fixed, point to point operations.

The conducted output power from the intentional radiator shall be reduced by the amount in dB that the directional gain of the antenna exceeds 6 dB

Fixed, point to point operations

Systems operating in the 2400–2483.5 MHz band that are used exclusively for fixed, point-to-point Operations, maximum peak output power of the intentional radiator is reduced by 1 dB for every 3 dB that the directional gain of the antenna exceeds 6 dBi.

### 3.2.2 Test Procedures

A broadband RF power meter is used for output power measurement. The video bandwidth of power meter is greater than DTS bandwidth of EUT. If duty cycle of test signal is not 100 %, trigger and gating function of power meter will be enabled to capture transmission burst for measuring output power.

### 3.2.3 Test Setup

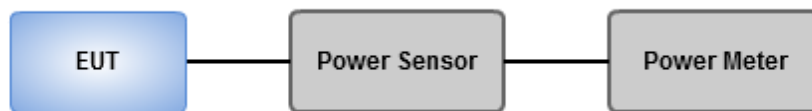

### 3.2.4 Test Results

<b>Ambient Condition</b>	20-26°C / 61-67%	<b>Tested By</b>	Aska Huang
--------------------------	------------------	------------------	------------

Refer to Appendix B.



### 3.3 Power Spectral Density

#### 3.3.1 Limit of Power Spectral Density

Power spectral density shall not be greater than 8 dBm in any 3 kHz band.

#### 3.3.2 Test Procedures

##### Peak PSD

1. Set the RBW = 3 kHz, VBW = 10 kHz.
2. Detector = Peak, Sweep time = auto couple.
3. Trace mode = max hold, allow trace to fully stabilize.
4. Use the peak marker function to determine the maximum amplitude level.

##### Average PSD, duty cycle $\geq$ 98%

1. Set the RBW = 3 kHz, VBW = 10 kHz.
2. Detector = RMS, Sweep time = auto couple.
3. Sweep time = auto couple.
4. Employ trace averaging (RMS) mode over a minimum of 100 traces.
5. Use the peak marker function to determine the maximum amplitude level.

##### Average PSD, duty cycle $<$ 98%

1. Set the RBW = 3 kHz, VBW = 10 kHz
2. Detector = RMS, Sweep time = auto couple.
3. Sweep time = auto couple.
4. Employ trace averaging (RMS) mode over a minimum of 100 traces.
5. Use the peak marker function to determine the maximum amplitude level.
6. Add  $10 \log (1/x)$ , where x is the duty cycle.

#### 3.3.3 Test Setup

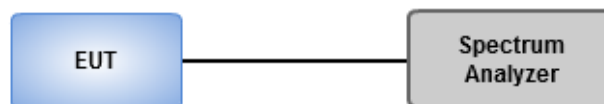

#### 3.3.4 Test Results

<b>Ambient Condition</b>	20-26°C / 61-67%	<b>Tested By</b>	Aska Huang
--------------------------	------------------	------------------	------------

Refer to Appendix C.

### 3.4 Unwanted Emissions into Restricted Frequency Bands

#### 3.4.1 Limit of Unwanted Emissions into Restricted Frequency Bands

Restricted Band Emissions Limit			
Frequency Range (MHz)	Field Strength (uV/m)	Field Strength (dBuV/m)	Measure Distance (m)
0.009~0.490	2400/F(kHz)	48.5 - 13.8	300
0.490~1.705	24000/F(kHz)	33.8 - 23	30
1.705~30.0	30	29	30
30~88	100	40	3
88~216	150	43.5	3
216~960	200	46	3
Above 960	500	54	3

**Note 1:**  
Qusai-Peak value is measured for frequency below 1GHz except for 9–90 kHz, 110–490 kHz frequency band. Peak and average value are measured for frequency above 1GHz. The limit on average radio frequency emission is as above table. The limit on peak radio frequency emissions is 20 dB above the maximum permitted average emission limit

**Note 2:**  
Measurements may be performed at a distance other than what is specified provided. When performing measurements at a distance other than that specified, the results shall be extrapolated to the specified distance using an extrapolation factor as below, Frequency at or above 30 MHz: 20 dB/decade Frequency below 30 MHz: 40 dB/decade.

#### 3.4.2 Test Procedures

1. Measurement is made at a semi-anechoic chamber that incorporates a turntable allowing a EUT rotation of 360°. A continuously-rotating, remotely-controlled turntable is installed at the test site to support the EUT and facilitate determination of the direction of maximum radiation for each EUT emission frequency. The EUT is placed at test table. For emissions testing at or below 1 GHz, the table height is 80 cm above the reference ground plane. For emission measurements above 1 GHz, the table height is 1.5 m
2. Measurement is made with the antenna positioned in both the horizontal and vertical planes of polarization. The measurement antenna is varied in height (1m ~ 4m) above the reference ground plane to obtain the maximum signal strength. Distance between EUT and antenna is 3 m.
3. This investigation is performed with the EUT rotated 360°, the antenna height scanned between 1 m and 4 m, and the antenna rotated to repeat the measurements for both the horizontal and vertical antenna polarizations.

Note:

1. 120kHz measurement bandwidth of test receiver and Quasi-peak detector is for radiated emission below 1GHz.
2. RBW=1MHz, VBW=3MHz and Peak detector is for peak measured value of radiated emission above 1GHz.
3. RBW=1MHz, VBW=1/T and Peak detector is for average measured value of radiated emission above 1GHz.

### 3.4.3 Test Setup

#### Radiated Emissions below 1 GHz

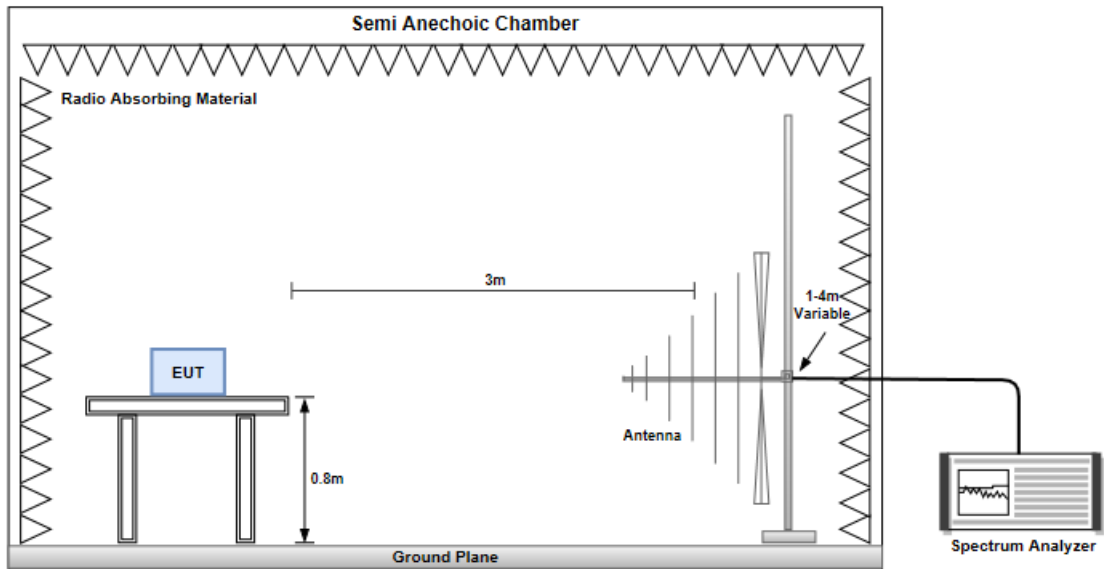

#### Radiated Emissions above 1 GHz

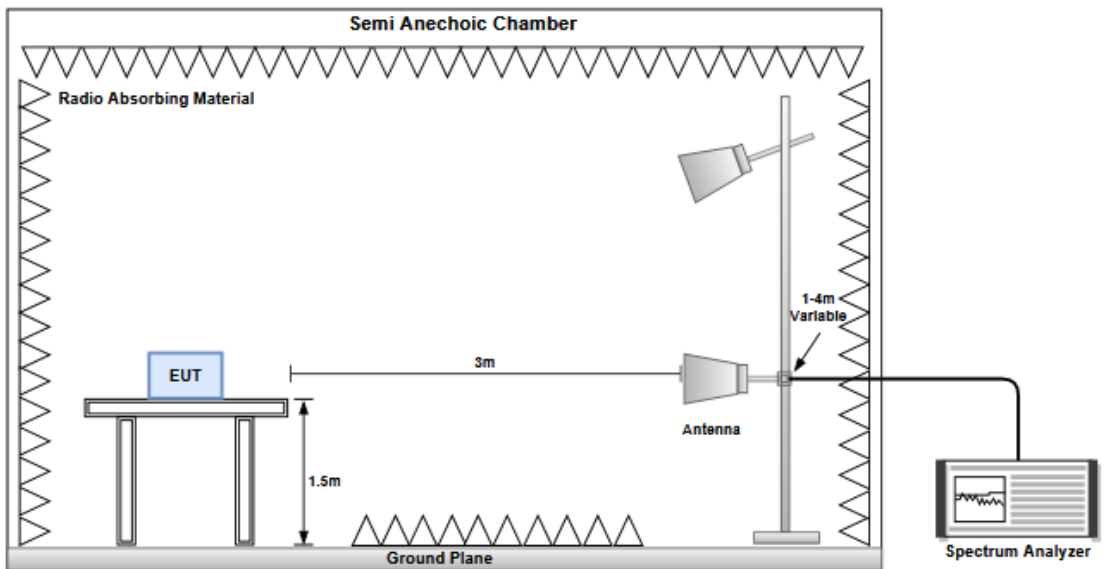

### 3.4.4 Test Results

Refer to Appendix D.

## 3.5 Emissions in Non-Restricted Frequency Bands

### 3.5.1 Emissions in Non-Restricted Frequency Bands Limit

Peak power in any 100 kHz bandwidth outside of the authorized frequency band shall be attenuated by at least 20 dB relative to the maximum in-band peak PSD level in 100 kHz.

### 3.5.2 Test Procedures

#### Reference level measurement

1. Set RBW=100kHz, VBW = 300kHz , Detector = Peak, Sweep time = Auto
2. Trace = max hold , Allow Trace to fully stabilize
3. Use the peak marker function to determine the maximum PSD level

#### Emission level measurement

1. Set RBW=100kHz, VBW = 300kHz , Detector = Peak, Sweep time = Auto
2. Trace = max hold , Allow Trace to fully stabilize
3. Scan Frequency range is up to 25GHz
4. Use the peak marker function to determine the maximum amplitude level

### 3.5.3 Test Setup

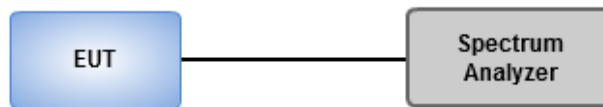

### 3.5.4 Test Results

<b>Ambient Condition</b>	20-26°C / 61-67%	<b>Tested By</b>	Aska Huang
--------------------------	------------------	------------------	------------

Refer to Appendix E.

## 3.6 AC Power Line Conducted Emissions

### 3.6.1 Limit of AC Power Line Conducted Emissions

Conducted Emissions Limit		
Frequency Emission (MHz)	Quasi-Peak	Average
0.15-0.5	66 - 56 *	56 - 46 *
0.5-5	56	46
5-30	60	50

Note 1: \* Decreases with the logarithm of the frequency.

### 3.6.2 Test Procedures

1. The device is placed on a test table, raised 80 cm above the reference ground plane. The vertical conducting plane is located 40 cm to the rear of the device.
2. The device is connected to line impedance stabilization network (LISN) and other accessories are connected to other LISN. Measured levels of AC power line conducted emission are across the 50  $\Omega$  LISN port.
3. AC conducted emission measurements is made over frequency range from 150 kHz to 30 MHz.
4. This measurement was performed with AC 120V / 60Hz.

### 3.6.3 Test Setup

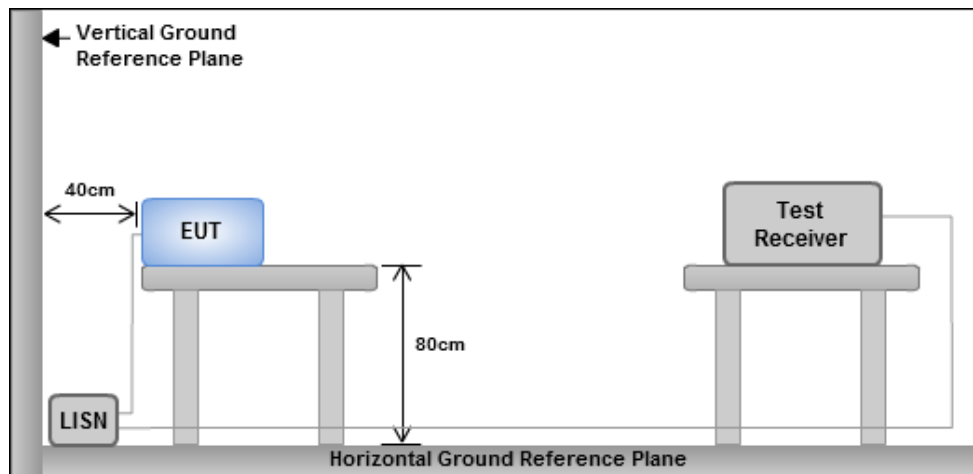

- Note: 1. Support units were connected to second LISN.  
 2. Both of LISNs (AMN) are 80 cm from EUT and at least 80 cm from other units and other metal planes

### 3.6.4 Test Results

Refer to Appendix F.

## 4 Test laboratory information

Established in 2012, ICC provides foremost EMC & RF Testing and advisory consultation services by our skilled engineers and technicians. Our services employ a wide variety of advanced edge test equipment and one of the widest certification extents in the business.

International Certification Corporation (EMC and Wireless Communication Laboratory), it is our definitive objective is to institute long term, trust-based associations with our clients. The expectation we set up with our clients is based on outstanding service, practical expertise and devotion to a certified value structure. Our passion is to grant our clients with best EMC / RF services by oriented knowledgeable and accommodating staff.

Our Test sites are located at Linkou District and Kwei Shan District. Location map can be found on our website <http://www.icertifi.com.tw>.

### **Linkou**

Tel: 886-2-2601-1640

No.30-2, Ding Fwu Tsuen, Lin Kou  
District, New Taipei City, Taiwan  
(R.O.C.)

### **Kwei Shan**

Tel: 886-3-271-8666

No.3-1, Lane 6, Wen San 3rd  
St., Kwei Shan Dist., Tao Yuan  
City 33381, Taiwan (R.O.C.)  
No.2-1, Lane 6, Wen San 3rd  
St., Kwei Shan Dist., Tao Yuan  
City 33381, Taiwan (R.O.C.)

### **Kwei Shan Site II**

Tel: 886-3-271-8640

No.14-1, Lane 19, Wen San 3rd  
St., Kwei Shan Dist., Tao Yuan  
City 33381, Taiwan (R.O.C.)

If you have any suggestion, please feel free to contact us as below information.

Tel: 886-3-271-8666

Fax: 886-3-318-0345

Email: ICC\_Service@icertifi.com.tw

==END==



Summary

Mode	Max-N dB (Hz)	Max-OBW (Hz)	ITU-Code	Min-N dB (Hz)	Min-OBW (Hz)
2.4-2.4835GHz	-	-	-	-	-
802.11b_Nss1,(1Mbps)_2TX	9.05M	12.204M	12M2G1D	8.075M	11.979M
802.11g_Nss1,(6Mbps)_2TX	16.325M	16.8M	16M8D1D	16.3M	16.602M
802.11ax HEW20_Nss1,(MCS0)_2TX_OFDMA	19.05M	19.065M	19M1D1D	18.95M	19.04M

Max-N dB = Maximum 6dB down bandwidth; Max-OBW = Maximum 99% occupied bandwidth;  
 Min-N dB = Minimum 6dB down bandwidth; Min-OBW = Minimum 99% occupied bandwidth

Result

Mode	Result	Limit (Hz)	Port 1-N dB (Hz)	Port 1-OBW (Hz)	Port 2-N dB (Hz)	Port 2-OBW (Hz)
802.11b_Nss1,(1Mbps)_2TX	-	-	-	-	-	-
2412MHz	Pass	500k	9.025M	12.024M	9.05M	12.039M
2437MHz	Pass	500k	8.55M	12.084M	8.075M	12.204M
2462MHz	Pass	500k	9M	11.979M	9.025M	11.994M
802.11g_Nss1,(6Mbps)_2TX	-	-	-	-	-	-
2412MHz	Pass	500k	16.3M	16.624M	16.3M	16.734M
2437MHz	Pass	500k	16.325M	16.646M	16.3M	16.8M
2462MHz	Pass	500k	16.3M	16.602M	16.3M	16.69M
802.11ax HEW20_Nss1,(MCS0)_2TX_OFDMA	-	-	-	-	-	-
2412MHz	Pass	500k	18.975M	19.04M	19.05M	19.065M
2437MHz	Pass	500k	18.95M	19.04M	19.05M	19.04M
2462MHz	Pass	500k	19.05M	19.04M	19.05M	19.065M

Port X-N dB = Port X 6dB down bandwidth;  
 Port X-OBW = Port X 99% occupied bandwidth



2.4-2.4835GHz\_802.11b\_Nss1,(1Mbps)\_2TX

EBW

2412MHz

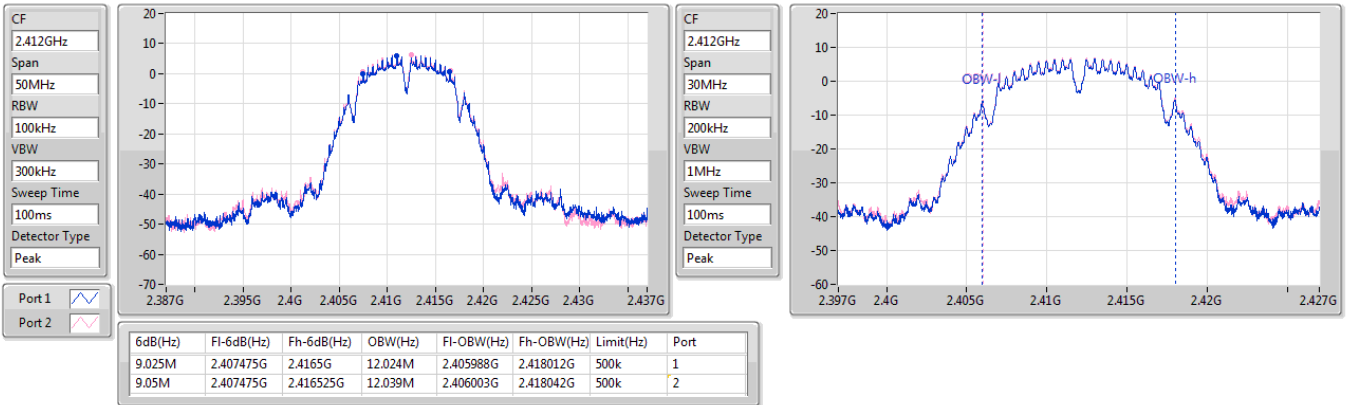

2.4-2.4835GHz\_802.11b\_Nss1,(1Mbps)\_2TX

EBW

2437MHz

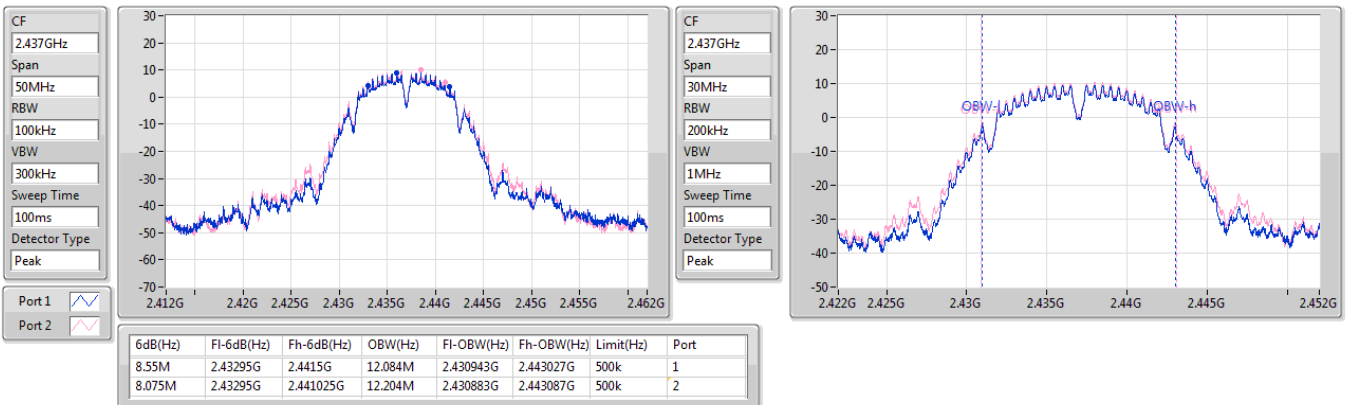





2.4-2.4835GHz\_802.11b\_Nss1,(1Mbps)\_2TX

EBW

2462MHz

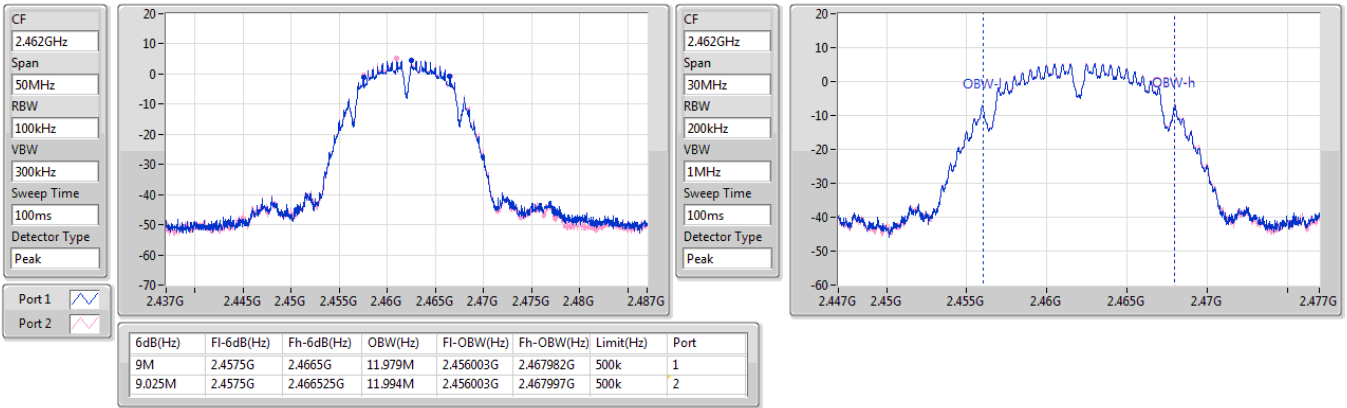

2.4-2.4835GHz\_802.11g\_Nss1,(6Mbps)\_2TX

EBW

2412MHz

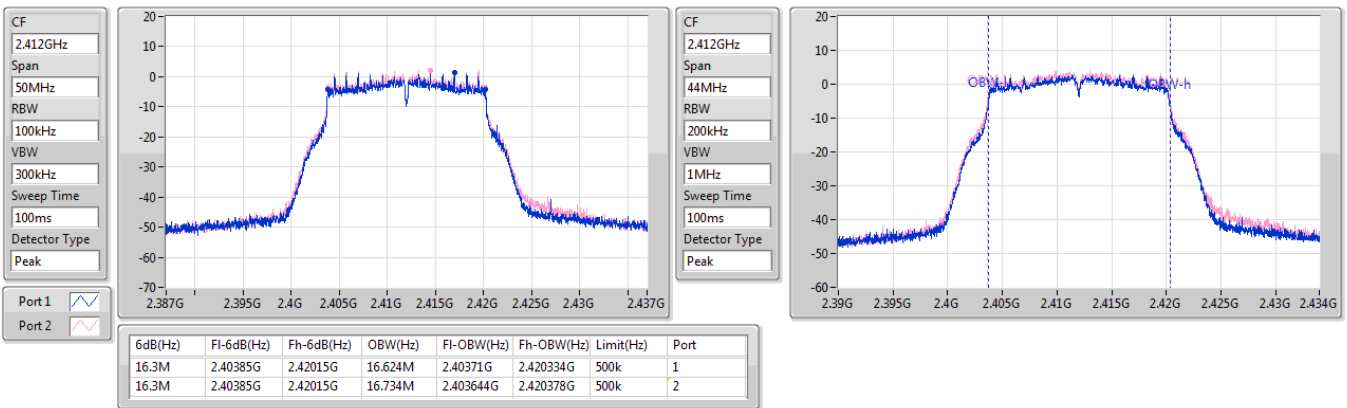



2.4-2.4835GHz\_802.11g\_Nss1,(6Mbps)\_2TX

EBW

2437MHz

CF: 2.437GHz  
 Span: 50MHz  
 RBW: 100kHz  
 VBW: 300kHz  
 Sweep Time: 100ms  
 Detector Type: Peak

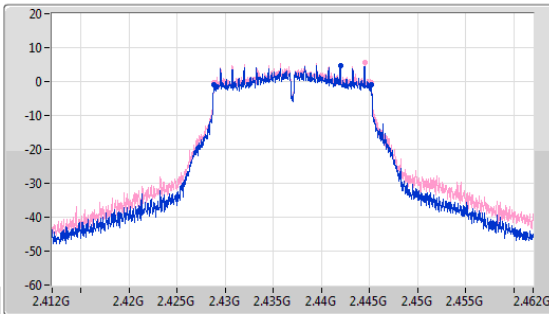

CF: 2.437GHz  
 Span: 44MHz  
 RBW: 200kHz  
 VBW: 1MHz  
 Sweep Time: 100ms  
 Detector Type: Peak

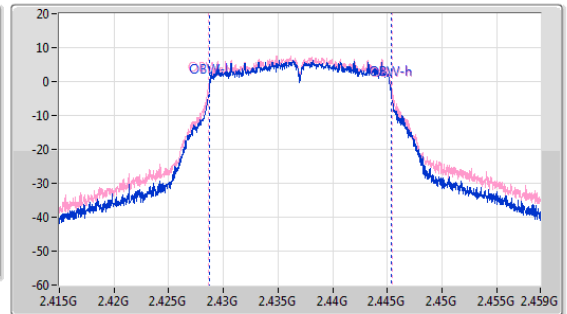

Port 1: [Waveform icon]  
 Port 2: [Waveform icon]

6dB(Hz)	Fl-6dB(Hz)	Fh-6dB(Hz)	OBW(Hz)	Fl-OBW(Hz)	Fh-OBW(Hz)	Limit(Hz)	Port
16.325M	2.428825G	2.44515G	16.646M	2.42871G	2.445356G	500k	1
16.3M	2.42885G	2.44515G	16.8M	2.428622G	2.445422G	500k	2

2.4-2.4835GHz\_802.11g\_Nss1,(6Mbps)\_2TX

EBW

2462MHz

CF: 2.462GHz  
 Span: 50MHz  
 RBW: 100kHz  
 VBW: 300kHz  
 Sweep Time: 100ms  
 Detector Type: Peak

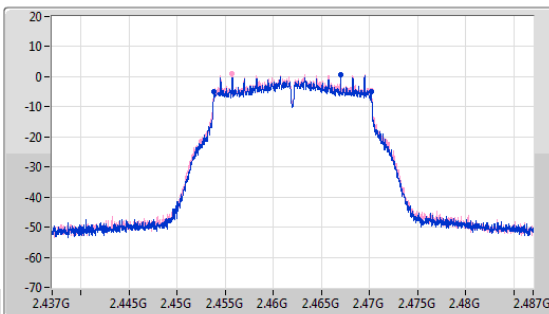

CF: 2.462GHz  
 Span: 44MHz  
 RBW: 200kHz  
 VBW: 1MHz  
 Sweep Time: 100ms  
 Detector Type: Peak

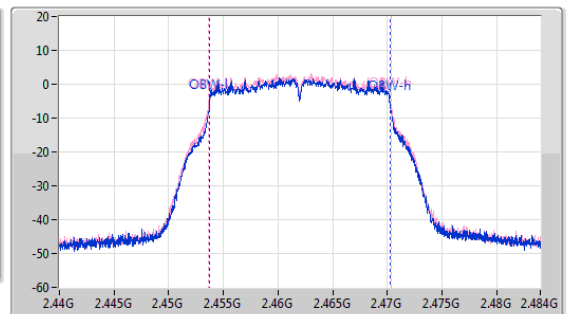

Port 1: [Waveform icon]  
 Port 2: [Waveform icon]

6dB(Hz)	Fl-6dB(Hz)	Fh-6dB(Hz)	OBW(Hz)	Fl-OBW(Hz)	Fh-OBW(Hz)	Limit(Hz)	Port
16.3M	2.45385G	2.47015G	16.602M	2.45371G	2.470312G	500k	1
16.3M	2.45385G	2.47015G	16.69M	2.453644G	2.470334G	500k	2



2.4-2.4835GHz\_802.11ax HEW20\_Nss1,(MCS0)\_2TX

EBW

2412MHz

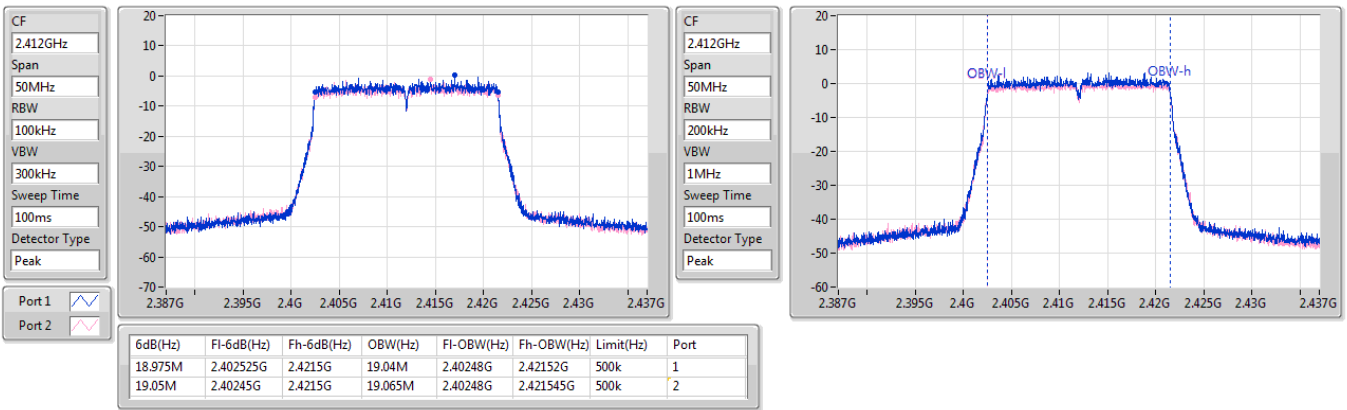

2.4-2.4835GHz\_802.11ax HEW20\_Nss1,(MCS0)\_2TX

EBW

2437MHz

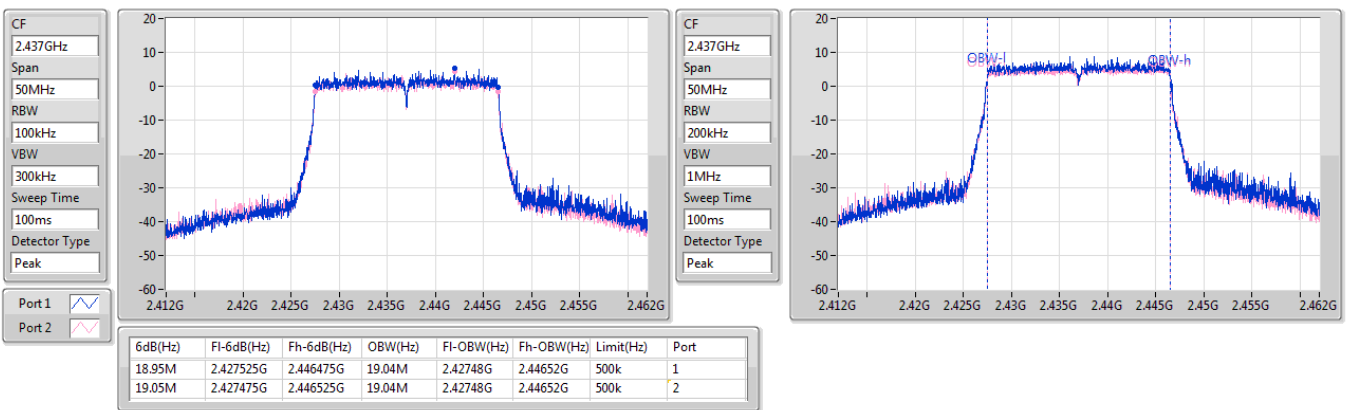



2.4-2.4835GHz\_802.11ax HEW20\_Nss1,(MCS0)\_2TX

EBW

2462MHz

CF: 2.462GHz  
 Span: 50MHz  
 RBW: 100kHz  
 VBW: 300kHz  
 Sweep Time: 100ms  
 Detector Type: Peak

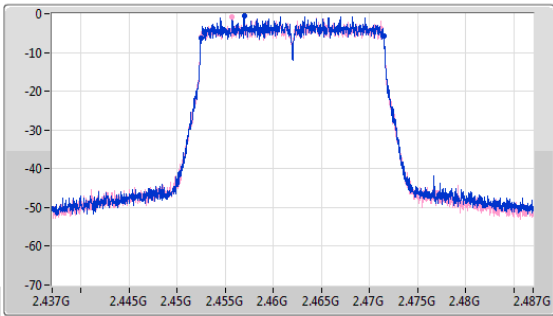

CF: 2.462GHz  
 Span: 50MHz  
 RBW: 200kHz  
 VBW: 1MHz  
 Sweep Time: 100ms  
 Detector Type: Peak

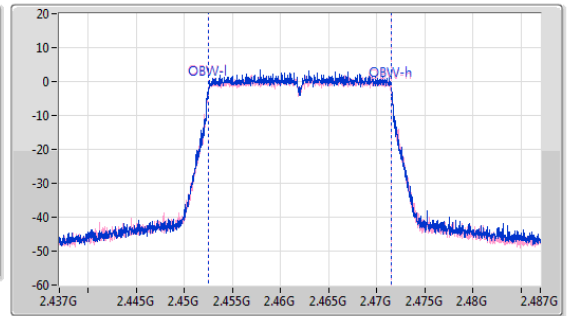

Port 1: [Waveform icon]  
 Port 2: [Waveform icon]

6dB(Hz)	Fl-6dB(Hz)	Fh-6dB(Hz)	OBW(Hz)	Fl-OBW(Hz)	Fh-OBW(Hz)	Limit(Hz)	Port
19.05M	2.45245G	2.4715G	19.04M	2.45248G	2.47152G	500k	1
19.05M	2.45245G	2.4715G	19.065M	2.45248G	2.471545G	500k	2



**Non-beamforming mode**

Summary

Mode	Total Power (dBm)	Total Power (W)
2.4-2.4835GHz	-	-
802.11b_Nss1,(1Mbps)_2TX	23.96	0.24889
802.11g_Nss1,(6Mbps)_2TX	26.02	0.39994
802.11ax HEW20_Nss1,(MCS0)_2TX-OFDMA	27.66	0.58345

Result

Mode	Result	DG (dBi)	Port 1 (dBm)	Port 2 (dBm)	Total Power (dBm)	Power Limit (dBm)	EIRP (dBm)	EIRP Limit (dBm)
802.11b_Nss1,(1Mbps)_2TX	-	-	-	-	-	-	-	-
2412MHz	Pass	2.40	18.1	18.27	21.20	30.00	23.60	36.00
2437MHz	Pass	2.40	20.63	21.24	23.96	30.00	26.36	36.00
2462MHz	Pass	2.40	16.08	16.74	19.43	30.00	21.83	36.00
802.11g_Nss1,(6Mbps)_2TX	-	-	-	-	-	-	-	-
2412MHz	Pass	2.40	19.03	19.05	22.05	30.00	24.45	36.00
2437MHz	Pass	2.40	22.77	23.24	26.02	30.00	28.42	36.00
2462MHz	Pass	2.40	17.39	18.7	21.10	30.00	23.50	36.00
802.11ax HEW20_Nss1,(MCS0)_2TX-OFDMA	-	-	-	-	-	-	-	-
2412MHz	Pass	2.40	19.66	20.22	22.96	30.00	25.36	36.00
2437MHz	Pass	2.40	24.69	24.61	27.66	30.00	30.06	36.00
2462MHz	Pass	2.40	20.15	20.18	23.18	30.00	25.58	36.00

DG = Directional Gain; Port X = Port X output power



Non-beamforming mode

Summary

Mode	Total Power (dBm)	Total Power (W)
2.4-2.4835GHz	-	-
802.11b_Nss1,(1Mbps)_2TX	21.02	0.12647
802.11g_Nss1,(6Mbps)_2TX	19.17	0.08260
802.11ax HEW20_Nss1,(MCS0)_2TX-OFDMA	19.15	0.08222

Result

Mode	Result	DG (dBi)	Port 1 (dBm)	Port 2 (dBm)	Total Power (dBm)	Power Limit (dBm)	EIRP (dBm)	EIRP Limit (dBm)
802.11b_Nss1,(1Mbps)_2TX	-	-	-	-	-	-	-	-
2412MHz	Pass	2.40	14.92	15.19	18.07	-	20.47	-
2437MHz	Pass	2.40	17.38	18.56	21.02	-	23.42	-
2462MHz	Pass	2.40	12.93	13.56	16.27	-	18.67	-
802.11g_Nss1,(6Mbps)_2TX	-	-	-	-	-	-	-	-
2412MHz	Pass	2.40	12.45	12.52	15.50	-	17.90	-
2437MHz	Pass	2.40	15.97	16.35	19.17	-	21.57	-
2462MHz	Pass	2.40	11.07	11.89	14.51	-	16.91	-
802.11ax HEW20_Nss1,(MCS0)_2TX-OFDMA	-	-	-	-	-	-	-	-
2412MHz	Pass	2.40	10.72	11.17	13.96	-	16.36	-
2437MHz	Pass	2.40	15.95	16.33	19.15	-	21.55	-
2462MHz	Pass	2.40	10.69	11.33	14.03	-	16.43	-

DG = Directional Gain; Port X = Port X output power  
Note : Conducted average output power is for reference



**Beamforming mode**

Summary

Mode	Total Power (dBm)	Total Power (W)
2.4-2.4835GHz	-	-
802.11ax HEW20-BF_Nss1,(MCS0)_2TX-OFDMA	24.65	0.29174

Result

Mode	Result	DG (dBi)	Port 1 (dBm)	Port 2 (dBm)	Total Power (dBm)	Power Limit (dBm)	EIRP (dBm)	EIRP Limit (dBm)
802.11ax HEW20-BF_Nss1,(MCS0)_2TX-OFDMA	-	-	-	-	-	-	-	-
2412MHz	Pass	5.41	16.65	17.21	19.95	30.00	25.36	36.00
2437MHz	Pass	5.41	21.68	21.6	24.65	30.00	30.06	36.00
2462MHz	Pass	5.41	17.14	17.17	20.17	30.00	25.58	36.00

DG = Directional Gain; Port X = Port X output power

Remarks:

Directional gain =  $2.4+10 \cdot \log(2/1)=5.41$  dBi



**Beamforming mode**

Summary

Mode	Total Power (dBm)	Total Power (W)
2.4-2.4835GHz	-	-
802.11ax HEW20-BF_Nss1,(MCS0)_2TX_OFDMA	16.14	0.04111

Result

Mode	Result	DG (dBi)	Port 1 (dBm)	Port 2 (dBm)	Total Power (dBm)	Power Limit (dBm)	EIRP (dBm)	EIRP Limit (dBm)
802.11ax HEW20-BF_Nss1,(MCS0)_2TX_OFDMA	-	-	-	-	-	-	-	-
2412MHz	Pass	5.41	7.71	8.16	10.95	-	16.36	-
2437MHz	Pass	5.41	12.94	13.32	16.14	-	21.55	-
2462MHz	Pass	5.41	7.68	8.32	11.02	-	16.43	-

DG = Directional Gain; Port X = Port X output power

Note : Conducted average output power is for reference

Remarks:

Directional gain =  $2.4+10 \cdot \log(2/1)=5.41$  dBi





**Non-beamforming mode**

Summary

Mode	Total Power (dBm)	Total Power (W)
2.4-2.4835GHz	-	-
802.11b_Nss1,(1Mbps)_2TX	23.53	0.22542
802.11g_Nss1,(6Mbps)_2TX	25.60	0.36308
802.11ax HEW20_Nss1,(MCS0)_2TX-OFDMA	26.91	0.49091

Result

Mode	Result	DG (dBi)	Port 1 (dBm)	Port 2 (dBm)	Total Power (dBm)	Power Limit (dBm)	EIRP (dBm)	EIRP Limit (dBm)
802.11b_Nss1,(1Mbps)_2TX	-	-	-	-	-	-	-	-
2412MHz	Pass	2.40	17.75	17.97	20.87	30.00	23.27	36.00
2437MHz	Pass	2.40	20.25	20.78	23.53	30.00	25.93	36.00
2462MHz	Pass	2.40	15.79	16.3	19.06	30.00	21.46	36.00
802.11g_Nss1,(6Mbps)_2TX	-	-	-	-	-	-	-	-
2412MHz	Pass	2.40	18.85	18.96	21.92	30.00	24.32	36.00
2437MHz	Pass	2.40	22.43	22.74	25.60	30.00	28.00	36.00
2462MHz	Pass	2.40	17.45	18.12	20.81	30.00	23.21	36.00
802.11ax HEW20_Nss1,(MCS0)_2TX-OFDMA	-	-	-	-	-	-	-	-
2412MHz	Pass	2.40	19.65	19.93	22.80	30.00	25.20	36.00
2437MHz	Pass	2.40	23.89	23.91	26.91	30.00	29.31	36.00
2462MHz	Pass	2.40	20.02	20.05	23.05	30.00	25.45	36.00

DG = Directional Gain; Port X = Port X output power



**Non-beamforming mode**

Summary

Mode	Total Power (dBm)	Total Power (W)
2.4-2.4835GHz	-	-
802.11b_Nss1,(1Mbps)_2TX	20.71	0.11776
802.11g_Nss1,(6Mbps)_2TX	18.89	0.07745
802.11ax HEW20_Nss1,(MCS0)_2TX-OFDMA	19.13	0.08185

Result

Mode	Result	DG (dBi)	Port 1 (dBm)	Port 2 (dBm)	Total Power (dBm)	Power Limit (dBm)	EIRP (dBm)	EIRP Limit (dBm)
802.11b_Nss1,(1Mbps)_2TX	-	-	-	-	-	-	-	-
2412MHz	Pass	2.40	14.62	14.81	17.73	-	20.13	-
2437MHz	Pass	2.40	17.32	18.05	20.71	-	23.11	-
2462MHz	Pass	2.40	12.61	13.15	15.90	-	18.30	-
802.11g_Nss1,(6Mbps)_2TX	-	-	-	-	-	-	-	-
2412MHz	Pass	2.40	12.25	12.32	15.30	-	17.70	-
2437MHz	Pass	2.40	15.61	16.13	18.89	-	21.29	-
2462MHz	Pass	2.40	11.12	11.38	14.26	-	16.66	-
802.11ax HEW20_Nss1,(MCS0)_2TX-OFDMA	-	-	-	-	-	-	-	-
2412MHz	Pass	2.40	10.64	10.92	13.79	-	16.19	-
2437MHz	Pass	2.40	16.01	16.22	19.13	-	21.53	-
2462MHz	Pass	2.40	10.65	10.72	13.70	-	16.10	-

DG = Directional Gain; Port X = Port X output power  
Note : Conducted average output power is for reference



**Beamforming mode**

Summary

Mode	Total Power (dBm)	Total Power (W)
2.4-2.4835GHz	-	-
802.11ax HEW20-BF_Nss1,(MCS0)_2TX-OFDMA	23.90	0.24547

Result

Mode	Result	DG (dBi)	Port 1 (dBm)	Port 2 (dBm)	Total Power (dBm)	Power Limit (dBm)	EIRP (dBm)	EIRP Limit (dBm)
802.11ax HEW20-BF_Nss1,(MCS0)_2TX-OFDMA	-	-	-	-	-	-	-	-
2412MHz	Pass	5.41	16.64	16.92	19.79	30.00	25.20	36.00
2437MHz	Pass	5.41	20.88	20.9	23.90	30.00	29.31	36.00
2462MHz	Pass	5.41	17.01	17.04	20.04	30.00	25.45	36.00

DG = Directional Gain; Port X = Port X output power

Remarks:

Directional gain =  $2.4+10 \cdot \log(2/1)=5.41$  dBi



**Beamforming mode**

Summary

Mode	Total Power (dBm)	Total Power (W)
2.4-2.4835GHz	-	-
802.11ax HEW20-BF_Nss1,(MCS0)_2TX-OFDMA	16.12	0.04093

Result

Mode	Result	DG (dBi)	Port 1 (dBm)	Port 2 (dBm)	Total Power (dBm)	Power Limit (dBm)	EIRP (dBm)	EIRP Limit (dBm)
802.11ax HEW20-BF_Nss1,(MCS0)_2TX-OFDMA	-	-	-	-	-	-	-	-
2412MHz	Pass	5.41	7.63	7.91	10.78	-	16.19	-
2437MHz	Pass	5.41	13	13.21	16.12	-	21.53	-
2462MHz	Pass	5.41	7.64	7.71	10.69	-	16.10	-

DG = Directional Gain; Port X = Port X output power

Note : Conducted average output power is for reference

Remarks:

Directional gain =  $2.4+10 \cdot \log(2/1)=5.41$  dBi



**Summary**

Mode	PD (dBm/RBW)
2.4-2.4835GHz	-
802.11b_Nss1,(1Mbps)_2TX	-2.55
802.11g_Nss1,(6Mbps)_2TX	-4.43
802.11ax HEW20_Nss1,(MCS0)_2TX-OFDMA	-5.46

RBW = 3kHz;

**Result**

Mode	Result	DG (dBi)	Port 1 (dBm/RBW)	Port 2 (dBm/RBW)	PD (dBm/RBW)	PD Limit (dBm/RBW)
802.11b_Nss1,(1Mbps)_2TX	-	-	-	-	-	-
2412MHz	Pass	5.41	-7.29	-5.87	-5.09	8.00
2437MHz	Pass	5.41	-4.95	-4.52	-2.55	8.00
2462MHz	Pass	5.41	-9.95	-8.95	-7.11	8.00
802.11g_Nss1,(6Mbps)_2TX	-	-	-	-	-	-
2412MHz	Pass	5.41	-12.00	-10.21	-8.48	8.00
2437MHz	Pass	5.41	-7.22	-7.67	-4.43	8.00
2462MHz	Pass	5.41	-13.18	-11.23	-9.30	8.00
802.11ax HEW20_Nss1,(MCS0)_2TX-OFDMA	-	-	-	-	-	-
2412MHz	Pass	5.41	-13.79	-15.36	-12.75	8.00
2437MHz	Pass	5.41	-7.60	-9.56	-5.46	8.00
2462MHz	Pass	5.41	-13.55	-13.64	-12.16	8.00

DG = Directional Gain; RBW = 3kHz;

PD = trace bin-by-bin of each transmits port summing can be performed maximum power density; Port X = Port X Power Density;

**Remarks:**

Directional gain =  $2.4+10 \cdot \log(2/1)=5.41$  dBi

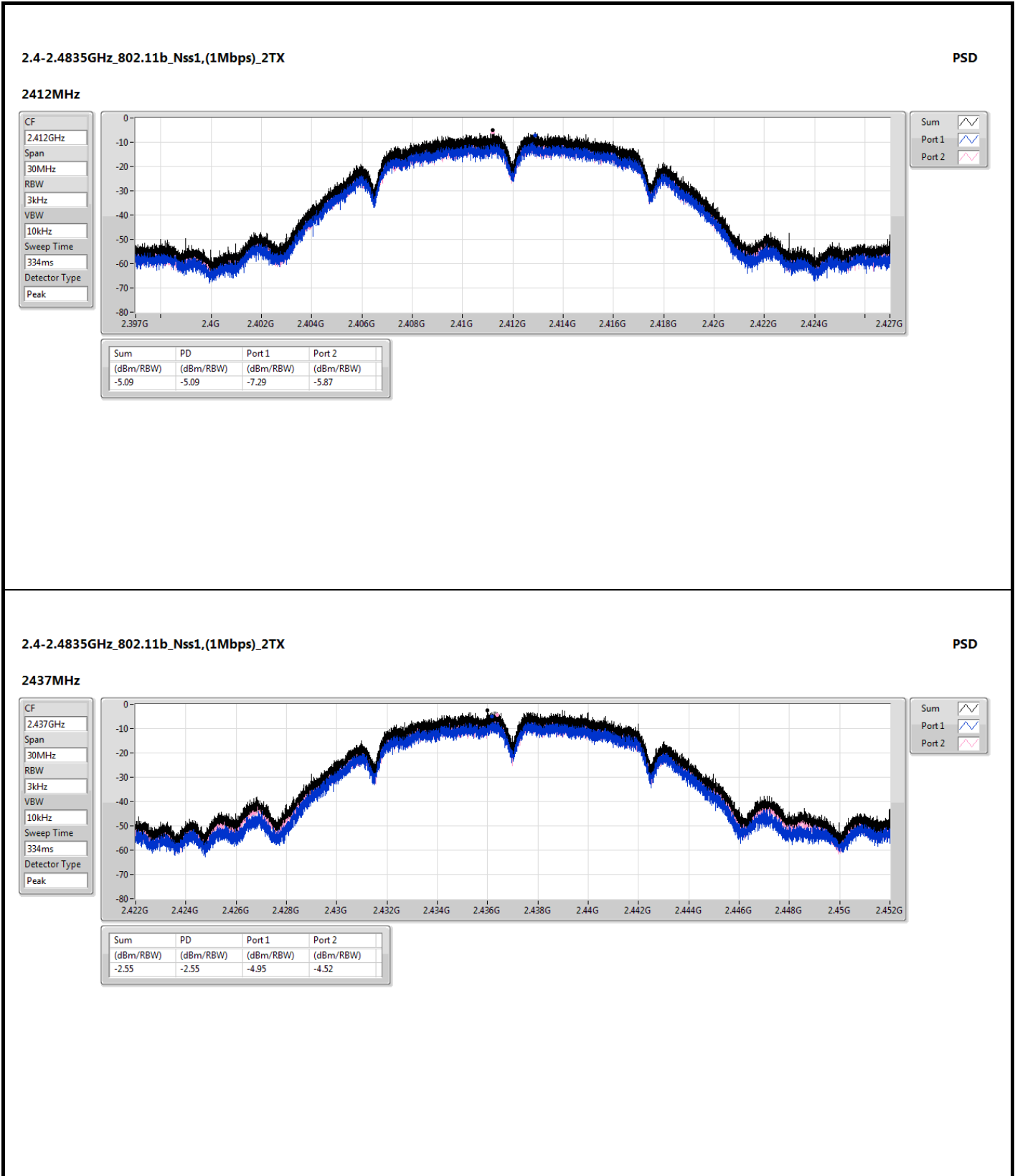



2.4-2.4835GHz\_802.11b\_Nss1,(1Mbps)\_2TX

PSD

2462MHz

CF  
2.462GHz  
Span  
30MHz  
RBW  
3kHz  
VBW  
10kHz  
Sweep Time  
334ms  
Detector Type  
Peak

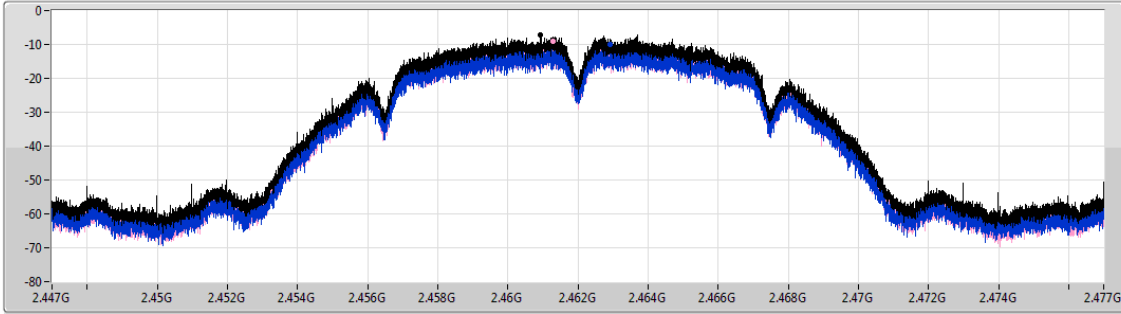

Sum  
Port 1  
Port 2

Sum	PD	Port 1	Port 2
(dBm/RBW)	(dBm/RBW)	(dBm/RBW)	(dBm/RBW)
-7.11	-7.11	-9.95	-8.95

2.4-2.4835GHz\_802.11g\_Nss1,(6Mbps)\_2TX

PSD

2412MHz

CF  
2.412GHz  
Span  
30MHz  
RBW  
3kHz  
VBW  
10kHz  
Sweep Time  
334ms  
Detector Type  
Peak

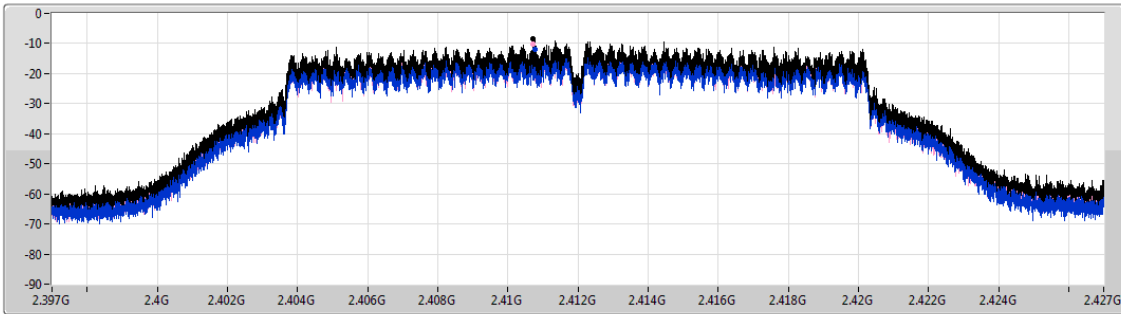

Sum  
Port 1  
Port 2

Sum	PD	Port 1	Port 2
(dBm/RBW)	(dBm/RBW)	(dBm/RBW)	(dBm/RBW)
-8.48	-8.48	-12.00	-10.21

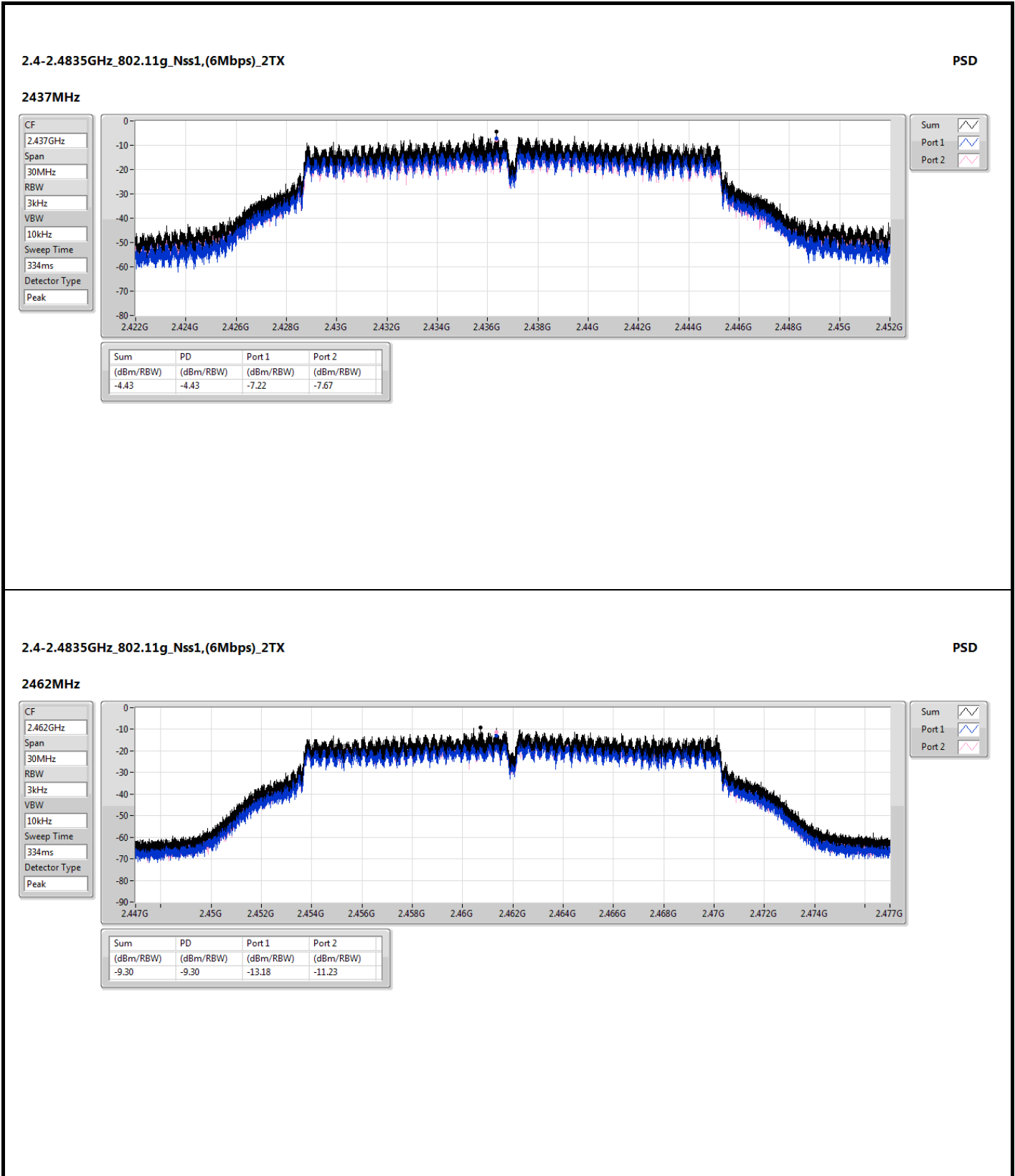





2.4-2.4835GHz\_802.11ax HEW20\_Nss1,(MCS0)\_2TX

PSD

2412MHz

CF  
2.412GHz  
Span  
30MHz  
RBW  
3kHz  
VBW  
10kHz  
Sweep Time  
334ms  
Detector Type  
Peak

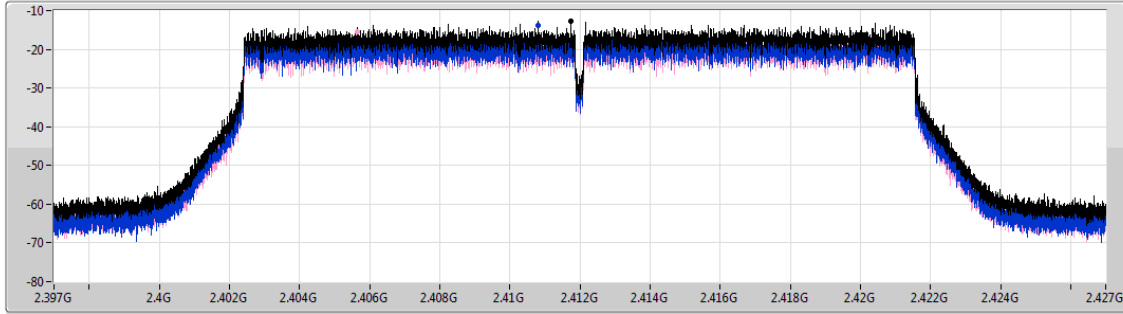

Sum	PD	Port 1	Port 2
(dBm/RBW)	(dBm/RBW)	(dBm/RBW)	(dBm/RBW)
-12.75	-12.75	-13.79	-15.36

2.4-2.4835GHz\_802.11ax HEW20\_Nss1,(MCS0)\_2TX

PSD

2437MHz

CF  
2.437GHz  
Span  
30MHz  
RBW  
3kHz  
VBW  
10kHz  
Sweep Time  
334ms  
Detector Type  
Peak

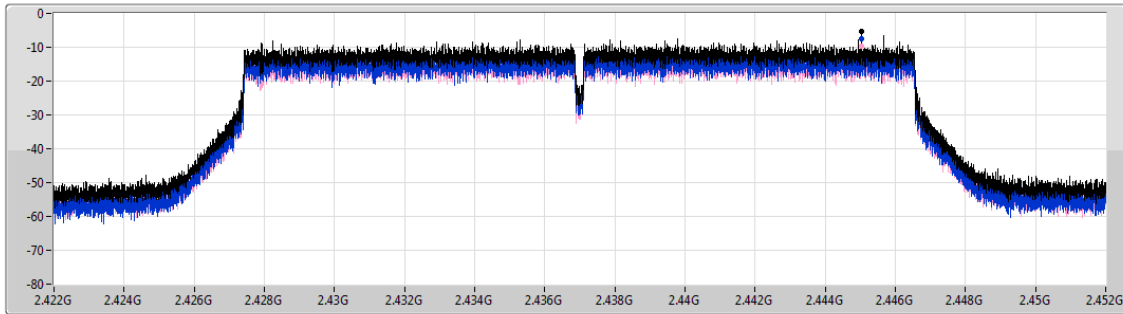

Sum	PD	Port 1	Port 2
(dBm/RBW)	(dBm/RBW)	(dBm/RBW)	(dBm/RBW)
-5.46	-5.46	-7.60	-9.56

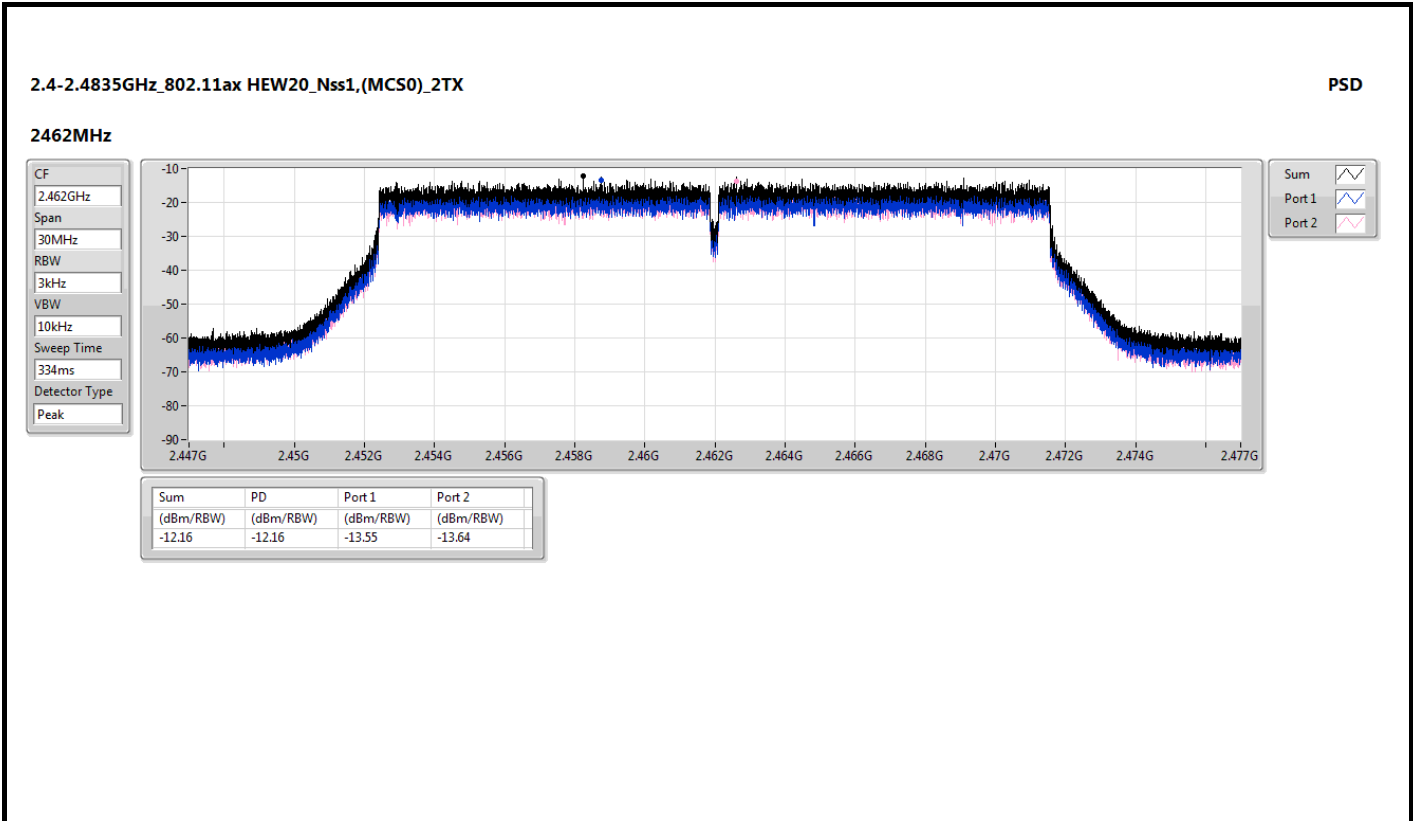



**Unwanted Conducted Emissions into Restricted  
Frequency Bands(30M~1GHz) - SC Module**

**Appendix D.1**

**Summary**

Mode	Result	F-Start (Hz)	F-Stop (Hz)	Type	Freq (Hz)	DG (dBi)	P1 (dBm)	P2 (dBm)	Psum (dBm)	GRF (dB)	EIRP (dBm)	Limit (dBm)	Margin (dB)
2.4-2.4835GHz	-	-	-	-	-	-	-	-	-	-	-	-	-
802.11ax HEW20_Nss1,(MCS0)_2TX-OFDMA	Pass	30M	1G	PK	37.71M	5.41	-82.65	-81.36	-78.95	4.7	-68.84	-55.20	-13.64

DG = Directional Gain ; PX=Port X; Psum=P1+P2+...PX

**Result**

Mode	Result	F-Start (Hz)	F-Stop (Hz)	Type	Freq (Hz)	DG (dBi)	P1 (dBm)	P2 (dBm)	Psum (dBm)	GRF (dB)	EIRP (dBm)	Limit (dBm)	Margin (dB)
802.11ax HEW20_Nss1,(MCS0)_2TX-OFDMA	-	-	-	-	-	-	-	-	-	-	-	-	-
2437MHz	Pass	30M	1G	PK	37.71M	5.41	-82.65	-81.36	-78.95	4.7	-68.84	-55.20	-13.64

DG = Directional Gain ; PX=Port X; Psum=P1+P2+...PX

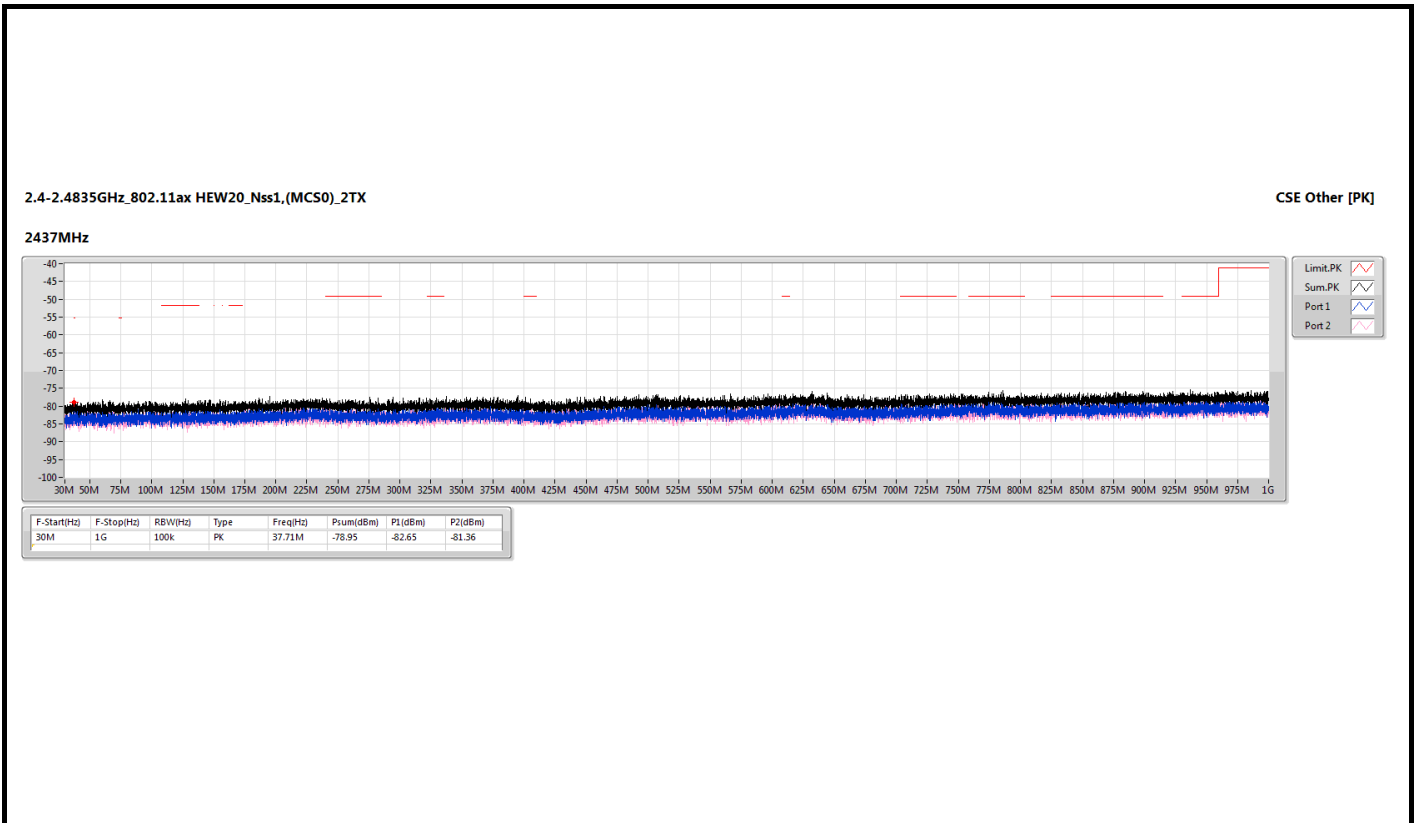



**Unwanted Conducted Emissions into Restricted Frequency Bands (1G~3.1GHz) - SC Module**

**Appendix D.2**

**Summary**

Mode	Result	F-Start (Hz)	F-Stop (Hz)	Type	Freq (Hz)	DG (dBi)	P1 (dBm)	P2 (dBm)	Psum (dBm)	EIRP (dBm)	Limit (dBm)	Margin (dB)
2.4-2.4835GHz	-	-	-	-	-	-	-	-	-	-	-	-
802.11b_Nss1,(1Mbps)_2TX	Pass	2.31G	2.39G	AV	2.39G	5.41	-51.15	-51.07	-48.10	-42.69	-41.20	-1.49
802.11g_Nss1,(6Mbps)_2TX	Pass	2.4835G	2.5G	AV	2.484G	5.41	-54.47	-50.15	-48.78	-43.37	-41.20	-2.17
802.11ax HEW20_Nss1,(MCS0)_2TX-OFDMA	Pass	2.31G	2.39G	AV	2.39G	5.41	-51.78	-52.70	-49.21	-43.80	-41.20	-2.60

DG = Directional Gain ; PX=Port X; Psum=P1+P2+...PX

**Result**

Mode	Result	F-Start (Hz)	F-Stop (Hz)	Type	Freq (Hz)	DG (dBi)	P1 (dBm)	P2 (dBm)	Psum (dBm)	EIRP (dBm)	Limit (dBm)	Margin (dB)
802.11b_Nss1,(1Mbps)_2TX	-	-	-	-	-	-	-	-	-	-	-	-
2412MHz	Pass	1G	2.31G	AV	2.31G	5.41	-61.46	-57.85	-56.28	-50.87	-41.20	-9.67
2412MHz	Pass	2.31G	2.39G	AV	2.39G	5.41	-51.15	-51.07	-48.10	-42.69	-41.20	-1.49
2412MHz	Pass	2.4835G	2.5G	AV	2.48526G	5.41	-58.24	-54.59	-53.03	-47.62	-41.20	-6.42
2412MHz	Pass	2.5G	3.1G	AV	2.5009G	5.41	-59.74	-55.01	-53.75	-48.34	-41.20	-7.14
2412MHz	Pass	1G	2.31G	PK	2.31G	5.41	-52.82	-50.51	-48.50	-43.09	-21.20	-21.89
2412MHz	Pass	2.31G	2.39G	PK	2.38996G	5.41	-41.54	-41.81	-38.66	-33.25	-21.20	-12.05
2412MHz	Pass	2.4835G	2.5G	PK	2.48546G	5.41	-49.62	-42.83	-42.00	-36.59	-21.20	-15.39
2412MHz	Pass	2.5G	3.1G	PK	2.5108G	5.41	-52.02	-45.40	-44.54	-39.13	-21.20	-17.93
2437MHz	Pass	1G	2.31G	AV	2.31G	5.41	-60.74	-56.92	-55.41	-50.00	-41.20	-8.80
2437MHz	Pass	2.31G	2.39G	AV	2.38572G	5.41	-57.35	-54.82	-52.89	-47.48	-41.20	-6.28
2437MHz	Pass	2.4835G	2.5G	AV	2.4836G	5.41	-55.88	-52.68	-50.98	-45.57	-41.20	-4.37
2437MHz	Pass	2.5G	3.1G	AV	2.5051G	5.41	-57.27	-53.59	-52.04	-46.63	-41.20	-5.43
2437MHz	Pass	1G	2.31G	PK	2.31G	5.41	-51.95	-49.51	-47.55	-42.14	-21.20	-20.94
2437MHz	Pass	2.31G	2.39G	PK	2.3536G	5.41	-50.01	-42.42	-41.72	-36.31	-21.20	-15.11
2437MHz	Pass	2.4835G	2.5G	PK	2.48352G	5.41	-45.05	-41.50	-39.91	-34.50	-21.20	-13.30
2437MHz	Pass	2.5G	3.1G	PK	2.5066G	5.41	-47.49	-44.00	-42.39	-36.98	-21.20	-15.78
2462MHz	Pass	1G	2.31G	AV	2.31G	5.41	-62.24	-59.87	-57.88	-52.47	-41.20	-11.27
2462MHz	Pass	2.31G	2.39G	AV	2.38592G	5.41	-60.96	-57.69	-56.01	-50.60	-41.20	-9.40
2462MHz	Pass	2.4835G	2.5G	AV	2.4835G	5.41	-51.95	-52.22	-49.07	-43.66	-41.20	-2.46
2462MHz	Pass	2.5G	3.1G	AV	2.5012G	5.41	-58.72	-56.08	-54.19	-48.78	-41.20	-7.58
2462MHz	Pass	1G	2.31G	PK	2.31G	5.41	-55.35	-51.55	-50.04	-44.63	-21.20	-23.43
2462MHz	Pass	2.31G	2.39G	PK	2.38824G	5.41	-48.88	-47.57	-45.17	-39.76	-21.20	-18.56
2462MHz	Pass	2.4835G	2.5G	PK	2.48734G	5.41	-41.26	-41.68	-38.45	-33.04	-21.20	-11.84
2462MHz	Pass	2.5G	3.1G	PK	2.5018G	5.41	-49.74	-44.62	-43.46	-38.05	-21.20	-16.85
802.11g_Nss1,(6Mbps)_2TX	-	-	-	-	-	-	-	-	-	-	-	-
2412MHz	Pass	1G	2.31G	AV	2.31G	5.41	-61.97	-59.08	-57.28	-51.87	-41.20	-10.67
2412MHz	Pass	2.31G	2.39G	AV	2.38964G	5.41	-52.74	-53.34	-50.02	-44.61	-41.20	-3.41
2412MHz	Pass	2.4835G	2.5G	AV	2.48741G	5.41	-60.03	-55.86	-54.45	-49.04	-41.20	-7.84
2412MHz	Pass	2.5G	3.1G	AV	2.5009G	5.41	-60.42	-56.51	-55.03	-49.62	-41.20	-8.42
2412MHz	Pass	1G	2.31G	PK	2.31G	5.41	-52.73	-50.65	-48.56	-43.15	-21.20	-21.95
2412MHz	Pass	2.31G	2.39G	PK	2.38936G	5.41	-40.57	-43.17	-38.67	-33.26	-21.20	-12.06



**Unwanted Conducted Emissions into Restricted Frequency Bands (1G~3.1GHz) - SC Module**

**Appendix D.2**

Mode	Result	F-Start (Hz)	F-Stop (Hz)	Type	Freq (Hz)	DG (dBi)	P1 (dBm)	P2 (dBm)	Psum (dBm)	EIRP (dBm)	Limit (dBm)	Margin (dB)
2412MHz	Pass	2.4835G	2.5G	PK	2.48354G	5.41	-49.69	-44.05	-43.00	-37.59	-21.20	-16.39
2412MHz	Pass	2.5G	3.1G	PK	2.5015G	5.41	-50.60	-45.67	-44.46	-39.05	-21.20	-17.85
2437MHz	Pass	1G	2.31G	AV	2.31G	5.41	-61.33	-57.89	-56.27	-50.86	-41.20	-9.66
2437MHz	Pass	2.31G	2.39G	AV	2.38964G	5.41	-55.43	-51.35	-49.92	-44.51	-41.20	-3.31
2437MHz	Pass	2.4835G	2.5G	AV	2.484G	5.41	-54.47	-50.15	-48.78	-43.37	-41.20	-2.17
2437MHz	Pass	2.5G	3.1G	AV	2.5003G	5.41	-56.24	-52.77	-51.16	-45.75	-41.20	-4.55
2437MHz	Pass	1G	2.31G	PK	2.31G	5.41	-53.06	-50.31	-48.46	-43.05	-21.20	-21.85
2437MHz	Pass	2.31G	2.39G	PK	2.3858G	5.41	-45.86	-36.17	-35.73	-30.32	-21.20	-9.12
2437MHz	Pass	2.4835G	2.5G	PK	2.48967G	5.41	-44.33	-36.11	-35.50	-30.09	-21.20	-8.89
2437MHz	Pass	2.5G	3.1G	PK	2.5024G	5.41	-47.28	-42.68	-41.39	-35.98	-21.20	-14.78
2462MHz	Pass	1G	2.31G	AV	2.31G	5.41	-62.67	-60.61	-58.51	-53.10	-41.20	-11.90
2462MHz	Pass	2.31G	2.39G	AV	2.38928G	5.41	-60.81	-58.63	-56.57	-51.16	-41.20	-9.96
2462MHz	Pass	2.4835G	2.5G	AV	2.48386G	5.41	-52.94	-53.46	-50.18	-44.77	-41.20	-3.57
2462MHz	Pass	2.5G	3.1G	AV	2.5G	5.41	-58.40	-56.85	-54.55	-49.14	-41.20	-7.94
2462MHz	Pass	1G	2.31G	PK	2.31G	5.41	-53.45	-52.60	-49.99	-44.58	-21.20	-23.38
2462MHz	Pass	2.31G	2.39G	PK	2.38708G	5.41	-49.07	-48.28	-45.65	-40.24	-21.20	-19.04
2462MHz	Pass	2.4835G	2.5G	PK	2.48351G	5.41	-41.75	-41.61	-38.67	-33.26	-21.20	-12.06
2462MHz	Pass	2.5G	3.1G	PK	2.5201G	5.41	-48.90	-47.93	-45.38	-39.97	-21.20	-18.77
802.11ax HEW20_Nss1,(MCS0)_2TX-OFDMA	-	-	-	-	-	-	-	-	-	-	-	-
2412MHz	Pass	1G	2.31G	AV	2.31G	5.41	-61.84	-60.61	-58.17	-52.76	-41.20	-11.56
2412MHz	Pass	2.31G	2.39G	AV	2.39G	5.41	-51.78	-52.70	-49.21	-43.80	-41.20	-2.60
2412MHz	Pass	2.4835G	2.5G	AV	2.48407G	5.41	-60.37	-58.11	-56.08	-50.67	-41.20	-9.47
2412MHz	Pass	2.5G	3.1G	AV	2.5003G	5.41	-60.77	-58.59	-56.53	-51.12	-41.20	-9.92
2412MHz	Pass	1G	2.31G	PK	2.31G	5.41	-53.26	-49.57	-48.02	-42.61	-21.20	-21.41
2412MHz	Pass	2.31G	2.39G	PK	2.38968G	5.41	-36.27	-36.44	-33.34	-27.93	-21.20	-6.73
2412MHz	Pass	2.4835G	2.5G	PK	2.49323G	5.41	-50.52	-46.53	-45.07	-39.66	-21.20	-18.46
2412MHz	Pass	2.5G	3.1G	PK	2.5045G	5.41	-50.77	-48.09	-46.22	-40.81	-21.20	-19.61
2437MHz	Pass	1G	2.31G	AV	2.31G	5.41	-61.58	-58.77	-56.94	-51.53	-41.20	-10.33
2437MHz	Pass	2.31G	2.39G	AV	2.38944G	5.41	-55.84	-55.43	-52.62	-47.21	-41.20	-6.01
2437MHz	Pass	2.4835G	2.5G	AV	2.4835G	5.41	-54.23	-53.67	-50.93	-45.52	-41.20	-4.32
2437MHz	Pass	2.5G	3.1G	AV	2.5G	5.41	-57.01	-54.75	-52.72	-47.31	-41.20	-6.11
2437MHz	Pass	1G	2.31G	PK	2.31G	5.41	-54.07	-51.66	-49.69	-44.28	-21.20	-23.08
2437MHz	Pass	2.31G	2.39G	PK	2.38936G	5.41	-40.16	-38.61	-36.31	-30.90	-21.20	-9.70
2437MHz	Pass	2.4835G	2.5G	PK	2.48864G	5.41	-36.02	-43.39	-35.29	-29.88	-21.20	-8.68
2437MHz	Pass	2.5G	3.1G	PK	2.5012G	5.41	-45.41	-45.62	-42.50	-37.09	-21.20	-15.89
2462MHz	Pass	1G	2.31G	AV	2.31G	5.41	-62.67	-61.58	-59.08	-53.67	-41.20	-12.47
2462MHz	Pass	2.31G	2.39G	AV	2.38924G	5.41	-61.06	-59.44	-57.16	-51.75	-41.20	-10.55
2462MHz	Pass	2.4835G	2.5G	AV	2.48363G	5.41	-52.09	-53.67	-49.80	-44.39	-41.20	-3.19
2462MHz	Pass	2.5G	3.1G	AV	2.5G	5.41	-58.59	-57.68	-55.10	-49.69	-41.20	-8.49
2462MHz	Pass	1G	2.31G	PK	2.31G	5.41	-52.97	-51.90	-49.39	-43.98	-21.20	-22.78
2462MHz	Pass	2.31G	2.39G	PK	2.35116G	5.41	-51.08	-47.77	-46.11	-40.70	-21.20	-19.50
2462MHz	Pass	2.4835G	2.5G	PK	2.48418G	5.41	-33.48	-43.47	-33.07	-27.66	-21.20	-6.46



**Unwanted Conducted Emissions into Restricted  
Frequency Bands (1G~3.1GHz) - SC Module**

**Appendix D.2**

Mode	Result	F-Start (Hz)	F-Stop (Hz)	Type	Freq (Hz)	DG (dBi)	P1 (dBm)	P2 (dBm)	Psum (dBm)	EIRP (dBm)	Limit (dBm)	Margin (dB)
2462MHz	Pass	2.5G	3.1G	PK	2.5015G	5.41	-49.34	-47.34	-45.22	-39.81	-21.20	-18.61

DG = Directional Gain ; PX=Port X; Psum=P1+P2+...PX



2.4-2.4835GHz\_802.11b\_Nss1,(1Mbps)\_2TX

CSE Bandedge [PK]

2412MHz

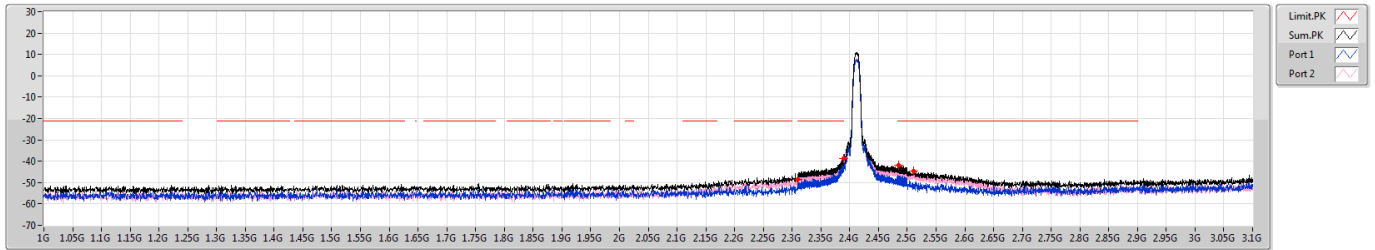

F-Start(Hz)	F-Stop(Hz)	RBW(Hz)	Type	Freq(Hz)	Psum(dBm)	P1(dBm)	P2(dBm)
1G	2.31G	1M	PK	2.31G	-48.50	-52.82	-50.51
2.31G	2.39G	1M	PK	2.38996G	-38.66	-41.54	-41.81
2.4835G	2.5G	1M	PK	2.48546G	-42.00	-49.62	-42.83
2.5G	3.1G	1M	PK	2.5100G	-44.54	-52.02	-45.40

2.4-2.4835GHz\_802.11b\_Nss1,(1Mbps)\_2TX

CSE Bandedge [AV]

2412MHz

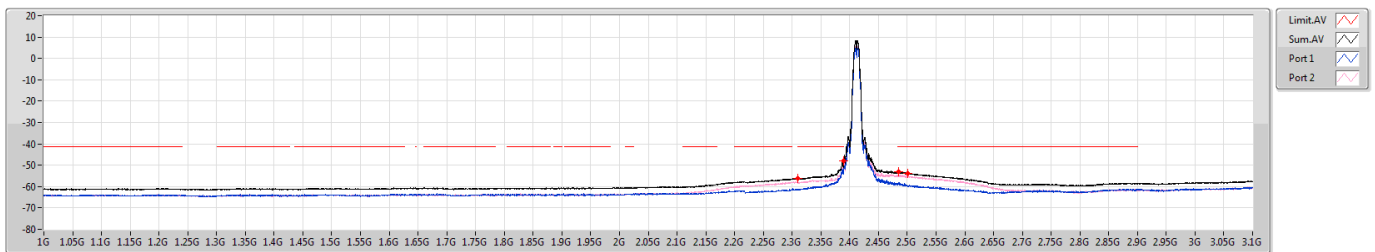

F-Start(Hz)	F-Stop(Hz)	RBW(Hz)	Type	Freq(Hz)	Psum(dBm)	P1(dBm)	P2(dBm)
1G	2.31G	1M	AV	2.31G	-56.28	-61.46	-57.85
2.31G	2.39G	1M	AV	2.39G	-48.10	-51.15	-51.07
2.4835G	2.5G	1M	AV	2.48526G	-53.03	-58.24	-54.59
2.5G	3.1G	1M	AV	2.5009G	-53.75	-59.74	-55.01





2.4-2.4835GHz\_802.11b\_Nss1,(1Mbps)\_2TX

CSE Bandedge [PK]

2437MHz

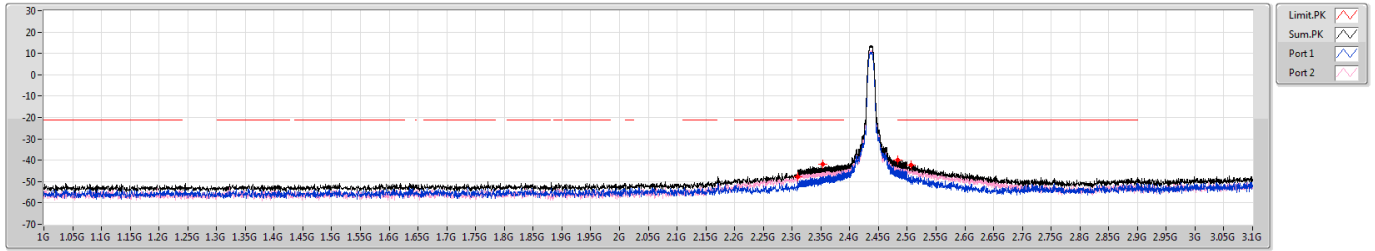

2.4-2.4835GHz\_802.11b\_Nss1,(1Mbps)\_2TX

CSE Bandedge [AV]

2437MHz

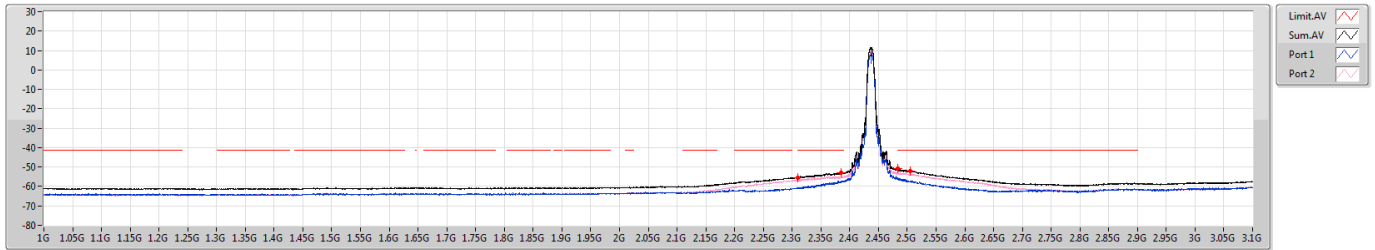



2.4-2.4835GHz\_802.11b\_Nss1,(1Mbps)\_2TX

CSE Bandedge [PK]

2462MHz

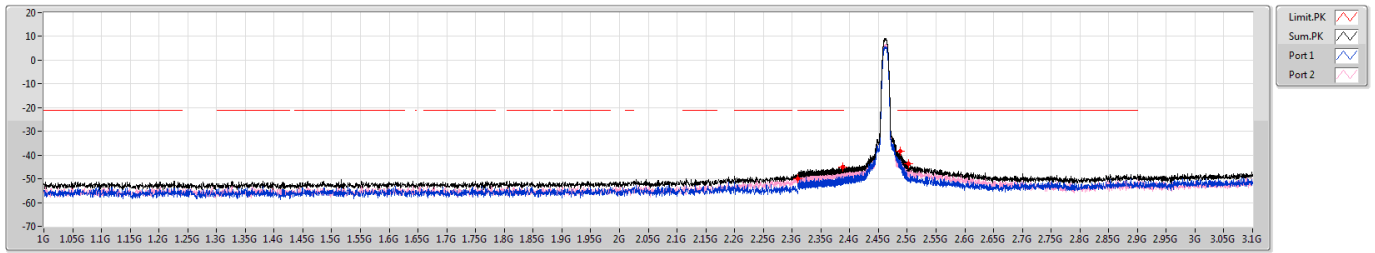

2.4-2.4835GHz\_802.11b\_Nss1,(1Mbps)\_2TX

CSE Bandedge [AV]

2462MHz

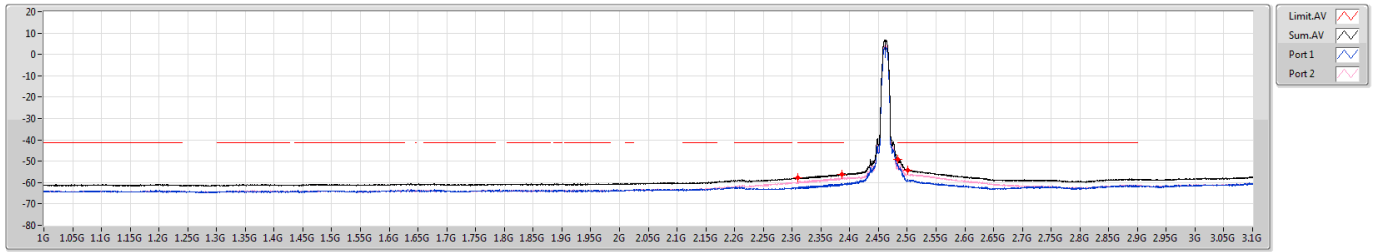



2.4-2.4835GHz\_802.11g\_Nss1,(6Mbps)\_2TX

CSE Bandedge [PK]

2412MHz

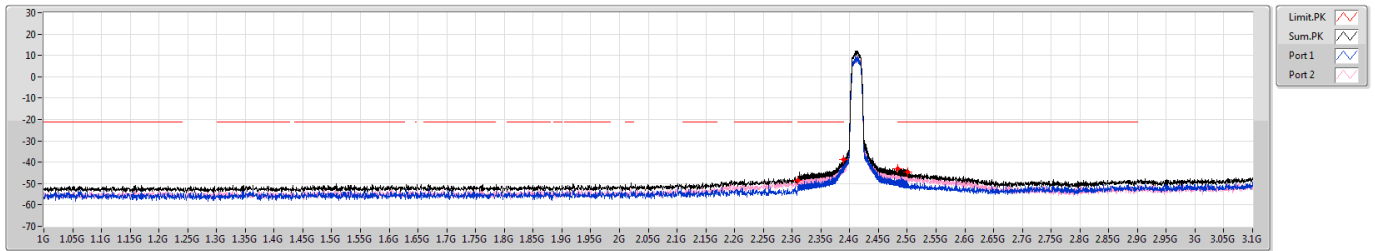

F-Start(Hz)	F-Stop(Hz)	RBW(Hz)	Type	Freq(Hz)	Psum(dBm)	P1(dBm)	P2(dBm)
1G	2.31G	1M	PK	2.31G	-48.56	-52.73	-50.65
2.31G	2.39G	1M	PK	2.38996G	-38.67	-40.57	-43.17
2.4835G	2.5G	1M	PK	2.48354G	-43.00	-49.69	-44.05
2.5G	3.1G	1M	PK	2.5015G	-44.46	-50.60	-45.67

2.4-2.4835GHz\_802.11g\_Nss1,(6Mbps)\_2TX

CSE Bandedge [AV]

2412MHz

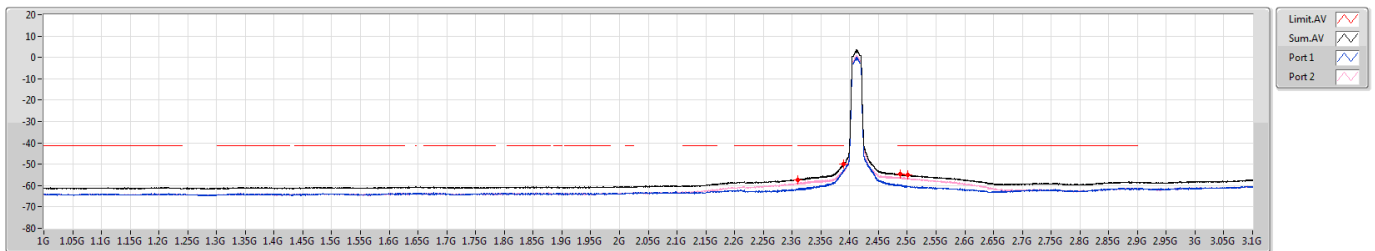

F-Start(Hz)	F-Stop(Hz)	RBW(Hz)	Type	Freq(Hz)	Psum(dBm)	P1(dBm)	P2(dBm)
1G	2.31G	1M	AV	2.31G	-57.28	-61.97	-59.08
2.31G	2.39G	1M	AV	2.38964G	-50.02	-52.74	-53.34
2.4835G	2.5G	1M	AV	2.48741G	-54.45	-60.03	-55.86
2.5G	3.1G	1M	AV	2.5009G	-55.03	-60.42	-56.51



2.4-2.4835GHz\_802.11g\_Nss1,(6Mbps)\_2TX

CSE Bandedge [PK]

2437MHz

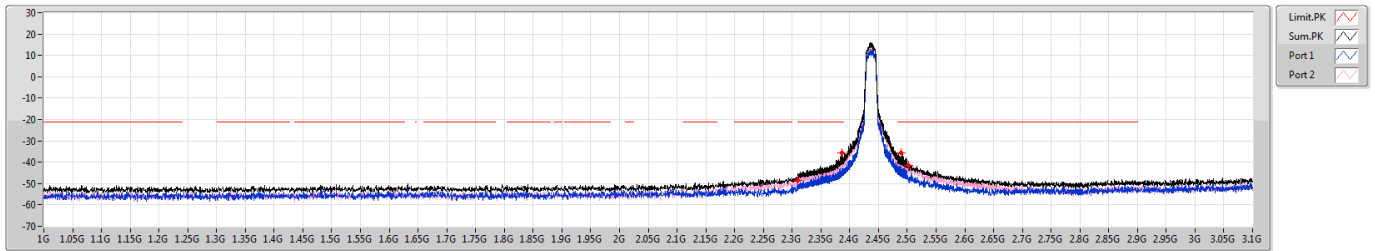

F-Start(Hz)	F-Stop(Hz)	RBW(Hz)	Type	Freq(Hz)	Psum(dBm)	P1(dBm)	P2(dBm)
1G	2.31G	1M	PK	2.31G	-48.46	-53.06	-50.31
2.31G	2.39G	1M	PK	2.3858G	-35.73	-45.86	-36.17
2.4835G	2.5G	1M	PK	2.48967G	-35.50	-44.33	-36.11
2.5G	3.1G	1M	PK	2.5024G	-41.39	-47.28	-42.68

2.4-2.4835GHz\_802.11g\_Nss1,(6Mbps)\_2TX

CSE Bandedge [AV]

2437MHz

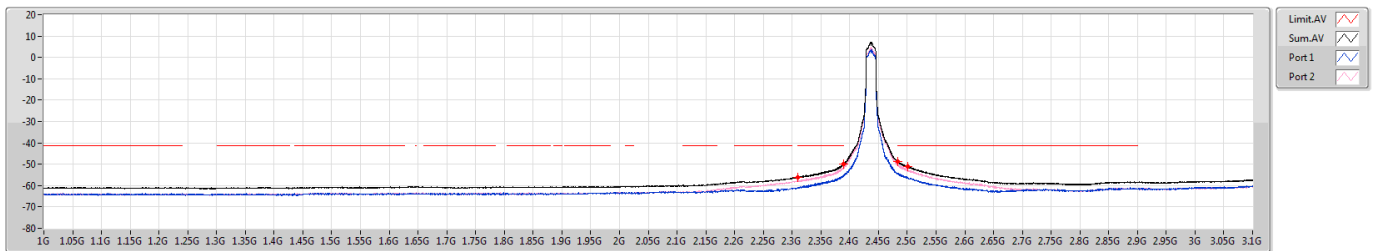

F-Start(Hz)	F-Stop(Hz)	RBW(Hz)	Type	Freq(Hz)	Psum(dBm)	P1(dBm)	P2(dBm)
1G	2.31G	1M	AV	2.31G	-56.27	-61.33	-57.89
2.31G	2.39G	1M	AV	2.38964G	-49.92	-55.43	-51.35
2.4835G	2.5G	1M	AV	2.484G	-48.78	-54.47	-50.15
2.5G	3.1G	1M	AV	2.5003G	-51.16	-56.24	-52.77



2.4-2.4835GHz\_802.11g\_Nss1,(6Mbps)\_2TX

CSE Bandedge [PK]

2462MHz

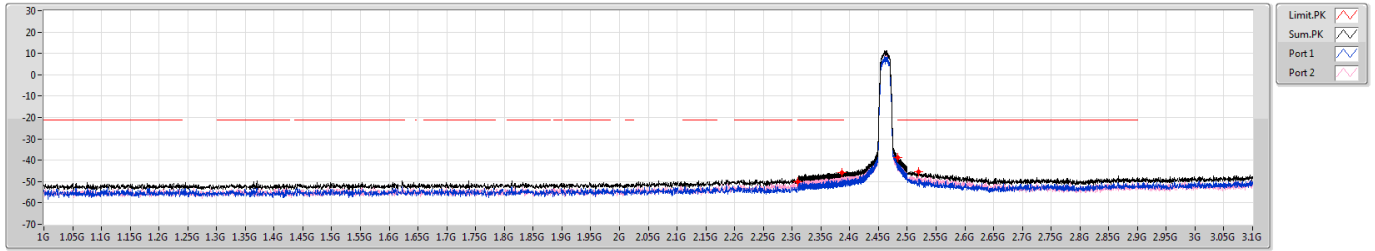

F-Start(Hz)	F-Stop(Hz)	RBW(Hz)	Type	Freq(Hz)	Psum(dBm)	P1(dBm)	P2(dBm)
1G	2.31G	1M	PK	2.31G	-49.99	-53.45	-52.60
2.31G	2.39G	1M	PK	2.38708G	-45.65	-49.07	-48.28
2.4835G	2.5G	1M	PK	2.48351G	-38.67	-41.75	-41.61
2.5G	3.1G	1M	PK	2.5201G	-45.38	-48.90	-47.93

2.4-2.4835GHz\_802.11g\_Nss1,(6Mbps)\_2TX

CSE Bandedge [AV]

2462MHz

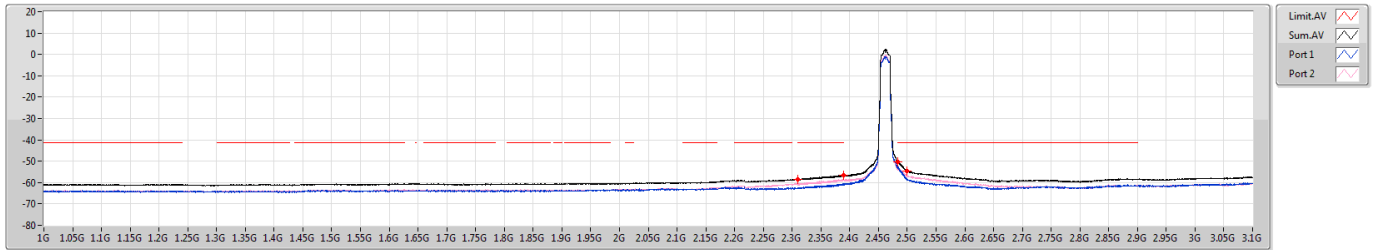

F-Start(Hz)	F-Stop(Hz)	RBW(Hz)	Type	Freq(Hz)	Psum(dBm)	P1(dBm)	P2(dBm)
1G	2.31G	1M	AV	2.31G	-58.51	-62.67	-60.61
2.31G	2.39G	1M	AV	2.38928G	-56.57	-60.81	-58.63
2.4835G	2.5G	1M	AV	2.48386G	-50.18	-52.94	-53.46
2.5G	3.1G	1M	AV	2.5G	-54.55	-58.40	-56.85



2.4-2.4835GHz\_802.11ax HEW20\_Nss1,(MCS0)\_2TX

CSE Bandedge [PK]

2412MHz

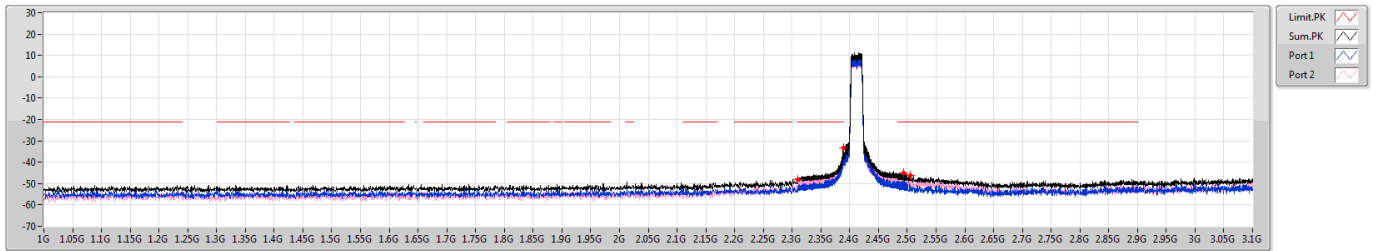

F-Start(Hz)	F-Stop(Hz)	RBW(Hz)	Type	Freq(Hz)	Psum(dBm)	P1(dBm)	P2(dBm)
1G	2.31G	1M	PK	2.31G	-48.02	-53.26	-49.57
2.31G	2.39G	1M	PK	2.38968G	-33.34	-36.27	-36.44
2.4835G	2.5G	1M	PK	2.49323G	-45.07	-50.52	-46.53
2.5G	3.1G	1M	PK	2.5045G	-46.22	-50.77	-48.09

2.4-2.4835GHz\_802.11ax HEW20\_Nss1,(MCS0)\_2TX

CSE Bandedge [AV]

2412MHz

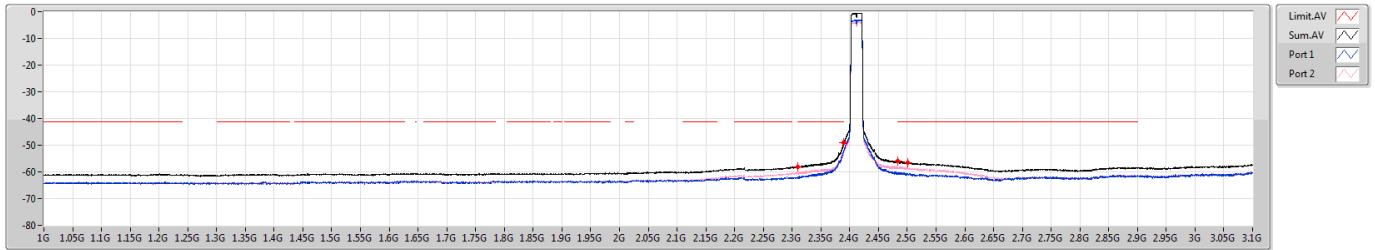

F-Start(Hz)	F-Stop(Hz)	RBW(Hz)	Type	Freq(Hz)	Psum(dBm)	P1(dBm)	P2(dBm)
1G	2.31G	1M	AV	2.31G	-58.17	-61.84	-60.61
2.31G	2.39G	1M	AV	2.39G	-49.21	-51.78	-52.70
2.4835G	2.5G	1M	AV	2.48407G	-56.08	-60.37	-58.11
2.5G	3.1G	1M	AV	2.5003G	-56.53	-60.77	-58.59



2.4-2.4835GHz\_802.11ax HEW20\_Nss1,(MCS0)\_2TX

CSE Bandedge [PK]

2437MHz

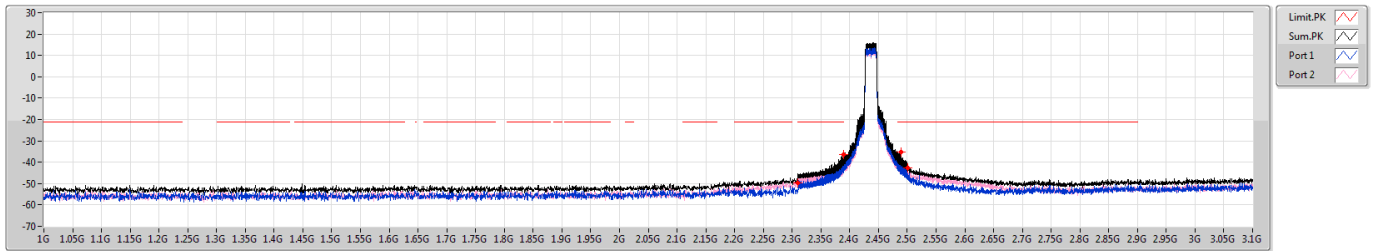

F-Start(Hz)	F-Stop(Hz)	RBW(Hz)	Type	Freq(Hz)	Psum(dBm)	P1(dBm)	P2(dBm)
1G	2.31G	1M	PK	2.31G	-49.69	-54.07	-51.66
2.31G	2.39G	1M	PK	2.38996G	-36.31	-40.16	-38.61
2.4835G	2.5G	1M	PK	2.48864G	-35.29	-36.02	-43.39
2.5G	3.1G	1M	PK	2.5012G	-42.50	-45.41	-45.62

2.4-2.4835GHz\_802.11ax HEW20\_Nss1,(MCS0)\_2TX

CSE Bandedge [AV]

2437MHz

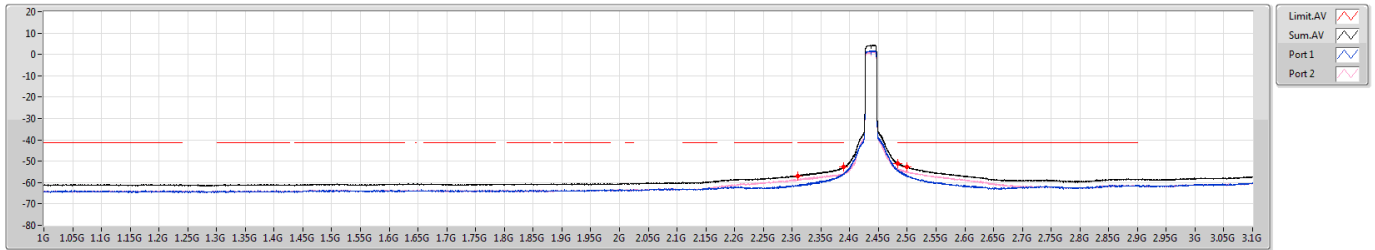

F-Start(Hz)	F-Stop(Hz)	RBW(Hz)	Type	Freq(Hz)	Psum(dBm)	P1(dBm)	P2(dBm)
1G	2.31G	1M	AV	2.31G	-56.94	-61.58	-58.77
2.31G	2.39G	1M	AV	2.38944G	-52.62	-55.84	-55.43
2.4835G	2.5G	1M	AV	2.4835G	-50.93	-54.23	-53.67
2.5G	3.1G	1M	AV	2.5G	-52.72	-57.01	-54.75



2.4-2.4835GHz\_802.11ax HEW20\_Nss1,(MCS0)\_2TX

CSE Bandedge [PK]

2462MHz

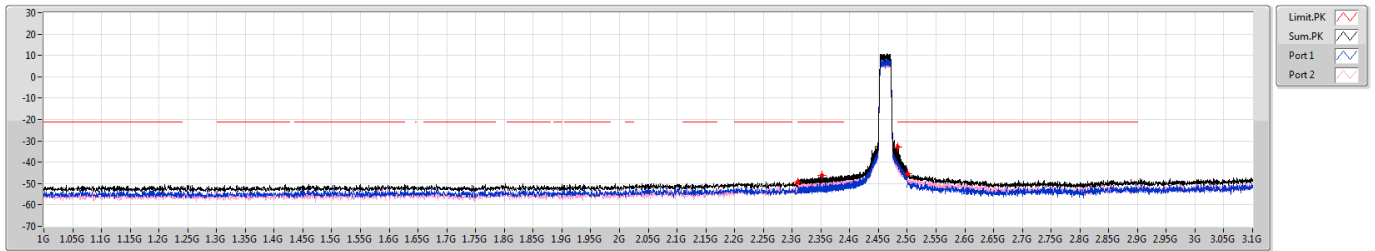

F-Start(Hz)	F-Stop(Hz)	RBW(Hz)	Type	Freq(Hz)	Psum(dBm)	P1(dBm)	P2(dBm)
1G	2.31G	1M	PK	2.31G	-49.39	-52.97	-51.90
2.31G	2.39G	1M	PK	2.35116G	-46.11	-51.08	-47.77
2.4835G	2.5G	1M	PK	2.48418G	-33.07	-33.48	-43.47
2.5G	3.1G	1M	PK	2.5015G	-45.22	-49.34	-47.34

2.4-2.4835GHz\_802.11ax HEW20\_Nss1,(MCS0)\_2TX

CSE Bandedge [AV]

2462MHz

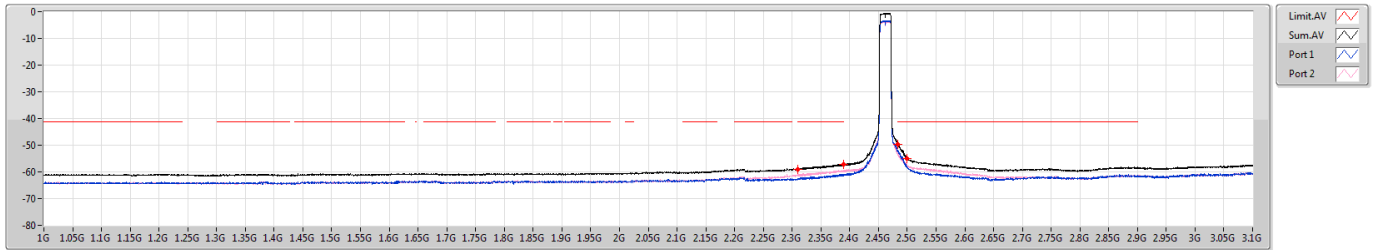

F-Start(Hz)	F-Stop(Hz)	RBW(Hz)	Type	Freq(Hz)	Psum(dBm)	P1(dBm)	P2(dBm)
1G	2.31G	1M	AV	2.31G	-59.08	-62.67	-61.58
2.31G	2.39G	1M	AV	2.38924G	-57.16	-61.06	-59.44
2.4835G	2.5G	1M	AV	2.48363G	-49.80	-52.09	-53.67
2.5G	3.1G	1M	AV	2.5G	-55.10	-58.59	-57.68





**Unwanted Conducted Emissions into Restricted Frequency Bands(3.1G~25GHz) - SC Module**

**Appendix D.3**

**Summary**

Mode	Result	F-Start (Hz)	F-Stop (Hz)	Type	Freq (Hz)	DG (dBi)	P1 (dBm)	P2 (dBm)	Psum (dBm)	EIRP (dBm)	Limit (dBm)	Margin (dB)
2.4-2.4835GHz	-	-	-	-	-	-	-	-	-	-	-	-
802.11b_Nss1,(1Mbps)_2TX	Pass	4G	5G	AV	4.874G	5.41	-50.17	-68.11	-50.10	-44.69	-41.20	-3.49
802.11g_Nss1,(6Mbps)_2TX	Pass	7G	8G	AV	7.3095G	5.41	-67.12	-57.61	-57.15	-51.74	-41.20	-10.54
802.11ax HEW20_Nss1,(MCS0)_2TX-OFDMA	Pass	4G	5G	AV	4.874G	5.41	-63.78	-60.80	-59.03	-53.62	-41.20	-12.42

DG = Directional Gain ; PX=Port X; Psum=P1+P2+...PX

**Result**

Mode	Result	F-Start (Hz)	F-Stop (Hz)	Type	Freq (Hz)	DG (dBi)	P1 (dBm)	P2 (dBm)	Psum (dBm)	EIRP (dBm)	Limit (dBm)	Margin (dB)
802.11b_Nss1,(1Mbps)_2TX	-	-	-	-	-	-	-	-	-	-	-	-
2412MHz	Pass	3.1G	4G	AV	3.61795G	5.41	-76.13	-73.63	-71.69	-66.28	-41.20	-25.08
2412MHz	Pass	4G	5G	AV	4.824G	5.41	-52.98	-65.37	-52.74	-47.33	-41.20	-6.13
2412MHz	Pass	5G	7G	AV	5.228G	5.41	-73.98	-73.72	-70.84	-65.43	-41.20	-24.23
2412MHz	Pass	7G	8G	AV	7.734G	5.41	-73.29	-73.13	-70.20	-64.79	-41.20	-23.59
2412MHz	Pass	8G	25G	AV	19.06913G	5.41	-65.90	-66.31	-63.09	-57.68	-41.20	-16.48
2412MHz	Pass	3.1G	4G	PK	3.91225G	5.41	-63.77	-66.88	-62.04	-56.63	-21.20	-35.43
2412MHz	Pass	4G	5G	PK	4.8245G	5.41	-51.60	-61.85	-51.21	-45.80	-21.20	-24.60
2412MHz	Pass	5G	7G	PK	5.2115G	5.41	-64.47	-63.51	-60.95	-55.54	-21.20	-34.34
2412MHz	Pass	7G	8G	PK	7.741G	5.41	-63.59	-65.46	-61.41	-56.00	-21.20	-34.80
2412MHz	Pass	8G	25G	PK	19.05106G	5.41	-58.42	-56.62	-54.42	-49.01	-21.20	-27.81
2437MHz	Pass	3.1G	4G	AV	3.6553G	5.41	-76.18	-73.91	-71.89	-66.48	-41.20	-25.28
2437MHz	Pass	4G	5G	AV	4.874G	5.41	-50.17	-68.11	-50.10	-44.69	-41.20	-3.49
2437MHz	Pass	5G	7G	AV	5.2045G	5.41	-74.37	-72.92	-70.57	-65.16	-41.20	-23.96
2437MHz	Pass	7G	8G	AV	7.31G	5.41	-60.84	-50.67	-50.27	-44.86	-41.20	-3.66
2437MHz	Pass	8G	25G	AV	19.06328G	5.41	-66.71	-65.88	-63.26	-57.85	-41.20	-16.65
2437MHz	Pass	3.1G	4G	PK	3.56755G	5.41	-64.07	-68.28	-62.67	-57.26	-21.20	-36.06
2437MHz	Pass	4G	5G	PK	4.8745G	5.41	-49.05	-62.90	-48.87	-43.46	-21.20	-22.26
2437MHz	Pass	5G	7G	PK	5.146G	5.41	-64.90	-64.73	-61.80	-56.39	-21.20	-35.19
2437MHz	Pass	7G	8G	PK	7.3105G	5.41	-57.26	-47.67	-47.22	-41.81	-21.20	-20.61
2437MHz	Pass	8G	25G	PK	19.53822G	5.41	-57.33	-57.33	-54.32	-48.91	-21.20	-27.71
2462MHz	Pass	3.1G	4G	AV	3.2629G	5.41	-74.92	-74.64	-71.77	-66.36	-41.20	-25.16
2462MHz	Pass	4G	5G	AV	4.924G	5.41	-58.20	-63.52	-57.08	-51.67	-41.20	-10.47
2462MHz	Pass	5G	7G	AV	5.204G	5.41	-73.86	-73.62	-70.73	-65.32	-41.20	-24.12
2462MHz	Pass	7G	8G	AV	7.387G	5.41	-73.77	-65.62	-65.00	-59.59	-41.20	-18.39
2462MHz	Pass	8G	25G	AV	19.0585G	5.41	-66.15	-66.42	-63.27	-57.86	-41.20	-16.66
2462MHz	Pass	3.1G	4G	PK	3.98155G	5.41	-67.25	-63.25	-61.79	-56.38	-21.20	-35.18
2462MHz	Pass	4G	5G	PK	4.9245G	5.41	-55.26	-60.06	-54.02	-48.61	-21.20	-27.41
2462MHz	Pass	5G	7G	PK	5.2465G	5.41	-63.62	-62.60	-60.07	-54.66	-21.20	-33.46
2462MHz	Pass	7G	8G	PK	7.387G	5.41	-66.42	-59.90	-59.03	-53.62	-21.20	-32.42
2462MHz	Pass	8G	25G	PK	15.73872G	5.41	-56.80	-56.13	-53.44	-48.03	-21.20	-26.83
802.11g_Nss1,(6Mbps)_2TX	-	-	-	-	-	-	-	-	-	-	-	-



**Unwanted Conducted Emissions into Restricted Frequency Bands(3.1G~25GHz) - SC Module**

**Appendix D.3**

Mode	Result	F-Start (Hz)	F-Stop (Hz)	Type	Freq (Hz)	DG (dBi)	P1 (dBm)	P2 (dBm)	Psum (dBm)	EIRP (dBm)	Limit (dBm)	Margin (dB)
2412MHz	Pass	3.1G	4G	AV	3.2647G	5.41	-75.02	-74.45	-71.72	-66.31	-41.20	-25.11
2412MHz	Pass	4G	5G	AV	4.824G	5.41	-67.57	-61.49	-60.53	-55.12	-41.20	-13.92
2412MHz	Pass	5G	7G	AV	5.249G	5.41	-73.54	-74.32	-70.90	-65.49	-41.20	-24.29
2412MHz	Pass	7G	8G	AV	7.747G	5.41	-73.54	-73.01	-70.26	-64.85	-41.20	-23.65
2412MHz	Pass	8G	25G	AV	19.09197G	5.41	-66.38	-66.10	-63.23	-57.82	-41.20	-16.62
2412MHz	Pass	3.1G	4G	PK	3.26695G	5.41	-66.70	-64.63	-62.53	-57.12	-21.20	-35.92
2412MHz	Pass	4G	5G	PK	4.8245G	5.41	-59.42	-57.76	-55.50	-50.09	-21.20	-28.89
2412MHz	Pass	5G	7G	PK	5.2145G	5.41	-64.31	-64.23	-61.26	-55.85	-21.20	-34.65
2412MHz	Pass	7G	8G	PK	7.723G	5.41	-63.61	-64.49	-61.02	-55.61	-21.20	-34.41
2412MHz	Pass	8G	25G	PK	19.424G	5.41	-57.17	-56.40	-53.76	-48.35	-21.20	-27.15
2437MHz	Pass	3.1G	4G	AV	3.2665G	5.41	-74.97	-74.69	-71.82	-66.41	-41.20	-25.21
2437MHz	Pass	4G	5G	AV	4.874G	5.41	-63.85	-61.13	-59.27	-53.86	-41.20	-12.66
2437MHz	Pass	5G	7G	AV	5.3865G	5.41	-74.14	-73.88	-71.00	-65.59	-41.20	-24.39
2437MHz	Pass	7G	8G	AV	7.3095G	5.41	-67.12	-57.61	-57.15	-51.74	-41.20	-10.54
2437MHz	Pass	8G	25G	AV	19.06913G	5.41	-65.77	-66.31	-63.02	-57.61	-41.20	-16.41
2437MHz	Pass	3.1G	4G	PK	3.92935G	5.41	-65.15	-65.77	-62.44	-57.03	-21.20	-35.83
2437MHz	Pass	4G	5G	PK	4.8755G	5.41	-53.43	-62.88	-52.96	-47.55	-21.20	-26.35
2437MHz	Pass	5G	7G	PK	5.4245G	5.41	-64.01	-65.15	-61.53	-56.12	-21.20	-34.92
2437MHz	Pass	7G	8G	PK	7.3G	5.41	-61.58	-47.64	-47.47	-42.06	-21.20	-20.86
2437MHz	Pass	8G	25G	PK	15.74616G	5.41	-58.13	-56.48	-54.22	-48.81	-21.20	-27.61
2462MHz	Pass	3.1G	4G	AV	3.26065G	5.41	-74.55	-74.55	-71.54	-66.13	-41.20	-24.93
2462MHz	Pass	4G	5G	AV	4.924G	5.41	-68.75	-60.76	-60.12	-54.71	-41.20	-13.51
2462MHz	Pass	5G	7G	AV	5.2475G	5.41	-73.79	-74.05	-70.91	-65.50	-41.20	-24.30
2462MHz	Pass	7G	8G	AV	7.3855G	5.41	-73.83	-70.96	-69.15	-63.74	-41.20	-22.54
2462MHz	Pass	8G	25G	AV	19.067G	5.41	-66.17	-66.03	-63.09	-57.68	-41.20	-16.48
2462MHz	Pass	3.1G	4G	PK	3.6166G	5.41	-65.57	-65.75	-62.65	-57.24	-21.20	-36.04
2462MHz	Pass	4G	5G	PK	4.9245G	5.41	-61.08	-58.33	-56.48	-51.07	-21.20	-29.87
2462MHz	Pass	5G	7G	PK	5.245G	5.41	-63.80	-64.29	-61.03	-55.62	-21.20	-34.42
2462MHz	Pass	7G	8G	PK	7.388G	5.41	-67.11	-61.18	-60.19	-54.78	-21.20	-33.58
2462MHz	Pass	8G	25G	PK	19.06859G	5.41	-57.04	-56.62	-53.81	-48.40	-21.20	-27.20
802.11ax HEW20_Nss1,(MCS0)_2TX-OFDMA	-	-	-	-	-	-	-	-	-	-	-	-
2412MHz	Pass	3.1G	4G	AV	3.2665G	5.41	-74.41	-74.41	-71.40	-65.99	-41.20	-24.79
2412MHz	Pass	4G	5G	AV	4.824G	5.41	-67.93	-61.09	-60.27	-54.86	-41.20	-13.66
2412MHz	Pass	5G	7G	AV	5.1665G	5.41	-74.12	-73.62	-70.85	-65.44	-41.20	-24.24
2412MHz	Pass	7G	8G	AV	7.7415G	5.41	-73.24	-73.24	-70.23	-64.82	-41.20	-23.62
2412MHz	Pass	8G	25G	AV	19.05159G	5.41	-66.27	-66.27	-63.26	-57.85	-41.20	-16.65
2412MHz	Pass	3.1G	4G	PK	3.9415G	5.41	-66.19	-64.94	-62.51	-57.10	-21.20	-35.90
2412MHz	Pass	4G	5G	PK	4.8245G	5.41	-59.84	-57.95	-55.78	-50.37	-21.20	-29.17
2412MHz	Pass	5G	7G	PK	5.185G	5.41	-65.72	-62.49	-60.80	-55.39	-21.20	-34.19
2412MHz	Pass	7G	8G	PK	7.737G	5.41	-65.24	-64.78	-61.99	-56.58	-21.20	-35.38
2412MHz	Pass	8G	25G	PK	18.41197G	5.41	-56.19	-58.54	-54.20	-48.79	-21.20	-27.59
2437MHz	Pass	3.1G	4G	AV	3.262G	5.41	-74.79	-74.52	-71.64	-66.23	-41.20	-25.03



**Unwanted Conducted Emissions into Restricted Frequency Bands(3.1G~25GHz) - SC Module**

**Appendix D.3**

Mode	Result	F-Start (Hz)	F-Stop (Hz)	Type	Freq (Hz)	DG (dBi)	P1 (dBm)	P2 (dBm)	Psum (dBm)	EIRP (dBm)	Limit (dBm)	Margin (dB)
2437MHz	Pass	4G	5G	AV	4.874G	5.41	-63.78	-60.80	-59.03	-53.62	-41.20	-12.42
2437MHz	Pass	5G	7G	AV	5.222G	5.41	-73.85	-73.60	-70.71	-65.30	-41.20	-24.10
2437MHz	Pass	7G	8G	AV	7.306G	5.41	-68.12	-62.25	-61.25	-55.84	-41.20	-14.64
2437MHz	Pass	8G	25G	AV	19.07338G	5.41	-66.76	-65.78	-63.23	-57.82	-41.20	-16.62
2437MHz	Pass	3.1G	4G	PK	3.3349G	5.41	-65.91	-65.08	-62.46	-57.05	-21.20	-35.85
2437MHz	Pass	4G	5G	PK	4.8745G	5.41	-55.46	-57.46	-53.34	-47.93	-21.20	-26.73
2437MHz	Pass	5G	7G	PK	5.3525G	5.41	-63.70	-64.51	-61.08	-55.67	-21.20	-34.47
2437MHz	Pass	7G	8G	PK	7.3115G	5.41	-57.00	-50.55	-49.66	-44.25	-21.20	-23.05
2437MHz	Pass	8G	25G	PK	19.41019G	5.41	-57.56	-57.08	-54.30	-48.89	-21.20	-27.69
2462MHz	Pass	3.1G	4G	AV	3.26155G	5.41	-74.53	-75.09	-71.79	-66.38	-41.20	-25.18
2462MHz	Pass	4G	5G	AV	4.924G	5.41	-68.48	-60.28	-59.67	-54.26	-41.20	-13.06
2462MHz	Pass	5G	7G	AV	5.246G	5.41	-74.06	-73.80	-70.92	-65.51	-41.20	-24.31
2462MHz	Pass	7G	8G	AV	7.74G	5.41	-73.44	-73.26	-70.34	-64.93	-41.20	-23.73
2462MHz	Pass	8G	25G	AV	19.07763G	5.41	-66.34	-66.20	-63.26	-57.85	-41.20	-16.65
2462MHz	Pass	3.1G	4G	PK	3.97705G	5.41	-64.53	-65.45	-61.96	-56.55	-21.20	-35.35
2462MHz	Pass	4G	5G	PK	4.9245G	5.41	-59.06	-57.09	-54.95	-49.54	-21.20	-28.34
2462MHz	Pass	5G	7G	PK	5.004G	5.41	-63.52	-65.39	-61.34	-55.93	-21.20	-34.73
2462MHz	Pass	7G	8G	PK	7.734G	5.41	-63.27	-65.07	-61.07	-55.66	-21.20	-34.46
2462MHz	Pass	8G	25G	PK	19.0585G	5.41	-56.20	-57.88	-53.95	-48.54	-21.20	-27.34

DG = Directional Gain ; PX=Port X; Psum=P1+P2+...PX



2.4-2.4835GHz\_802.11b\_Nss1,(1Mbps)\_2TX

CSE [PK]

2412MHz

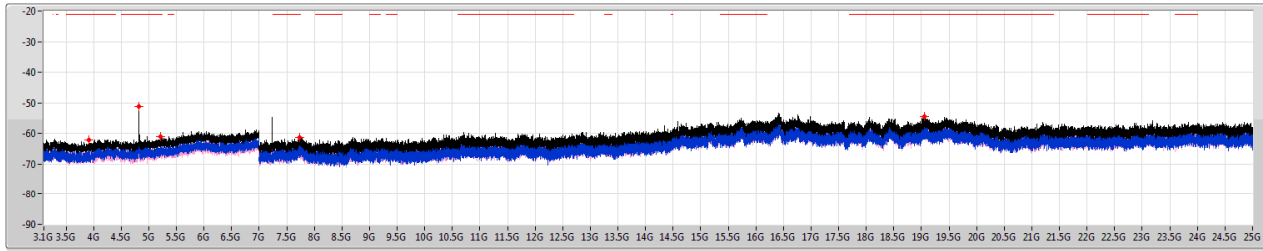

F-Start(Hz)	F-Stop(Hz)	RBW(Hz)	Type	Freq(Hz)	Psum(dBm)	P1(dBm)	P2(dBm)
3.1G	4G	1M	PK	3.91225G	-62.04	-63.77	-66.88
4G	5G	1M	PK	4.8245G	-51.21	-51.60	-61.85
5G	7G	1M	PK	5.2115G	-60.95	-64.47	-63.51
7G	8G	1M	PK	7.741G	-61.41	-63.59	-65.46
8G	25G	1M	PK	19.05106G	-54.42	-58.42	-56.62

2.4-2.4835GHz\_802.11b\_Nss1,(1Mbps)\_2TX

CSE [AV]

2412MHz

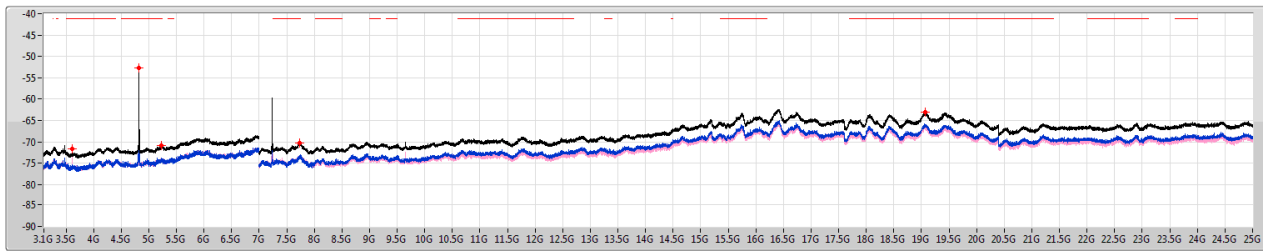

F-Start(Hz)	F-Stop(Hz)	RBW(Hz)	Type	Freq(Hz)	Psum(dBm)	P1(dBm)	P2(dBm)
3.1G	4G	1M	AV	3.61795G	-71.69	-76.13	-73.63
4G	5G	1M	AV	4.824G	-52.74	-52.98	-65.37
5G	7G	1M	AV	5.228G	-70.84	-73.98	-73.72
7G	8G	1M	AV	7.734G	-70.20	-73.29	-73.13
8G	25G	1M	AV	19.06913G	-63.09	-65.90	-66.31



# Unwanted Conducted Emissions into Restricted Frequency Bands(3.1G~25GHz) - SC Module

## Appendix D.3

2.4-2.4835GHz\_802.11b\_Nss1,(1Mbps)\_2TX

CSE [PK]

2437MHz

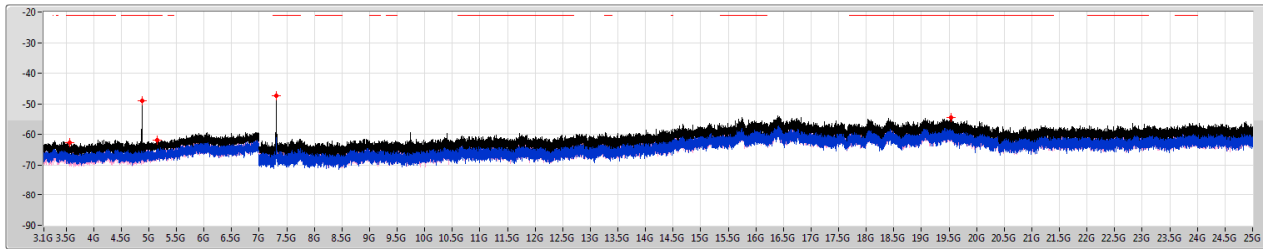

Limit.PK

Sum.PK

Port.1

Port.2

F-Start(Hz)	F-Stop(Hz)	RBW(Hz)	Type	Freq(Hz)	Psum(dBm)	P1(dBm)	P2(dBm)
3.1G	4G	1M	PK	3.56755G	-62.67	-64.07	-68.28
4G	5G	1M	PK	4.8745G	-48.87	-49.05	-62.90
5G	7G	1M	PK	5.146G	-61.80	-64.90	-64.73
7G	8G	1M	PK	7.3105G	-47.22	-57.26	-47.67
8G	25G	1M	PK	19.53822G	-54.32	-57.33	-57.33

2.4-2.4835GHz\_802.11b\_Nss1,(1Mbps)\_2TX

CSE [AV]

2437MHz

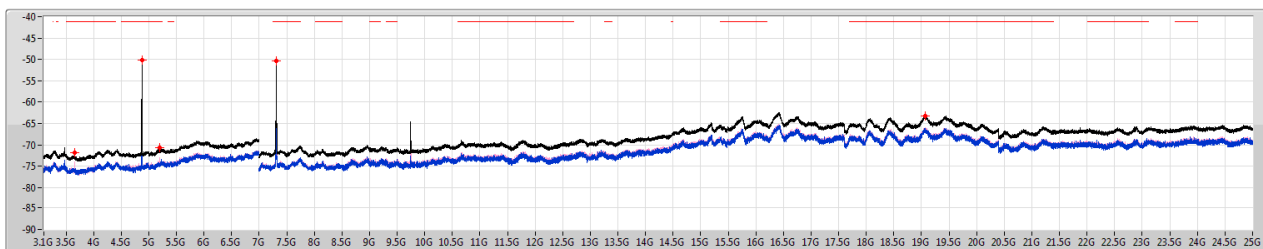

Limit.AV

Sum.AV

Port.1

Port.2

F-Start(Hz)	F-Stop(Hz)	RBW(Hz)	Type	Freq(Hz)	Psum(dBm)	P1(dBm)	P2(dBm)
3.1G	4G	1M	AV	3.6553G	-71.89	-76.18	-73.91
4G	5G	1M	AV	4.874G	-50.10	-50.17	-68.11
5G	7G	1M	AV	5.2045G	-70.57	-74.37	-72.92
7G	8G	1M	AV	7.31G	-50.27	-60.84	-50.67
8G	25G	1M	AV	19.06328G	-63.26	-66.71	-65.88



2.4-2.4835GHz\_802.11b\_Nss1,(1Mbps)\_2TX

CSE [PK]

2462MHz

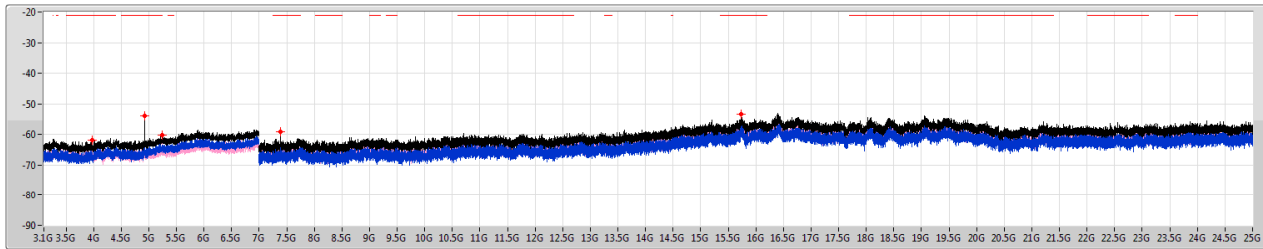

Limit.PK

Sum.PK

Port.1

Port.2

F-Start(Hz)	F-Stop(Hz)	RBW(Hz)	Type	Freq(Hz)	Psum(dBm)	P1(dBm)	P2(dBm)
3.1G	4G	1M	PK	3.98155G	-61.79	-67.25	-63.25
4G	5G	1M	PK	4.9245G	-54.02	-55.26	-60.06
5G	7G	1M	PK	5.2465G	-60.07	-63.62	-62.60
7G	8G	1M	PK	7.387G	-59.03	-66.42	-59.90
8G	25G	1M	PK	15.73872G	-53.44	-56.80	-56.13

2.4-2.4835GHz\_802.11b\_Nss1,(1Mbps)\_2TX

CSE [AV]

2462MHz

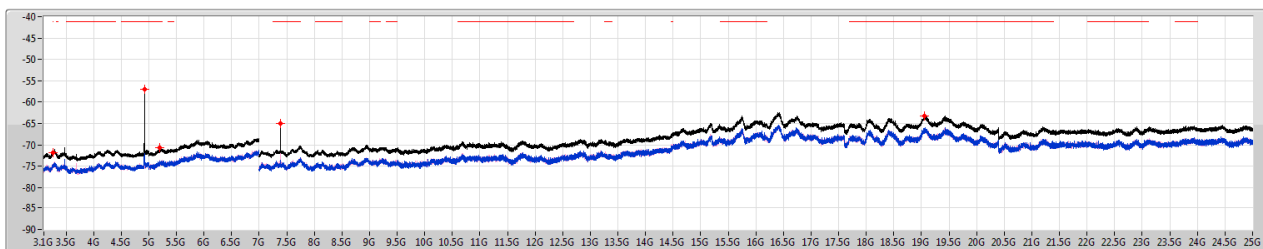

Limit.AV

Sum.AV

Port.1

Port.2

F-Start(Hz)	F-Stop(Hz)	RBW(Hz)	Type	Freq(Hz)	Psum(dBm)	P1(dBm)	P2(dBm)
3.1G	4G	1M	AV	3.2629G	-71.77	-74.92	-74.64
4G	5G	1M	AV	4.924G	-57.08	-58.20	-63.52
5G	7G	1M	AV	5.204G	-70.73	-73.96	-73.62
7G	8G	1M	AV	7.387G	-65.00	-73.77	-65.62
8G	25G	1M	AV	19.0585G	-63.27	-66.15	-66.42



# Unwanted Conducted Emissions into Restricted Frequency Bands(3.1G~25GHz) - SC Module

## Appendix D.3

2.4-2.4835GHz\_802.11g\_Nss1,(6Mbps)\_2TX

CSE [PK]

2412MHz

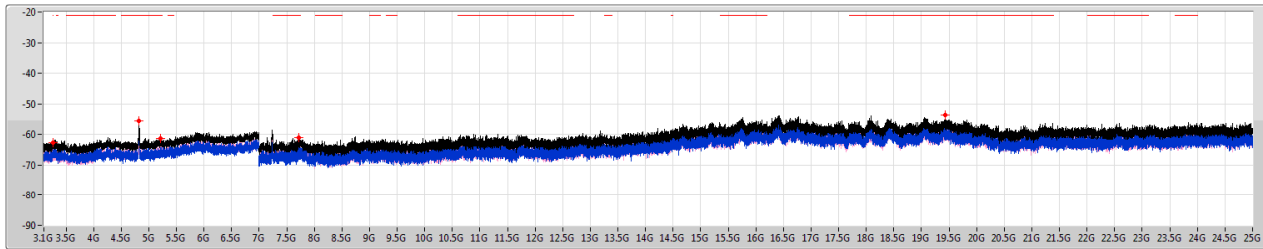

Limit.PK

Sum.PK

Port.1

Port.2

F-Start(Hz)	F-Stop(Hz)	RBW(Hz)	Type	Freq(Hz)	Psum(dBm)	P1(dBm)	P2(dBm)
3.1G	4G	1M	PK	3.26695G	-62.53	-66.70	-64.63
4G	5G	1M	PK	4.8245G	-55.50	-59.42	-57.76
5G	7G	1M	PK	5.2145G	-61.26	-64.31	-64.23
7G	8G	1M	PK	7.723G	-61.02	-63.61	-64.49
8G	25G	1M	PK	19.424G	-53.76	-57.17	-56.40

2.4-2.4835GHz\_802.11g\_Nss1,(6Mbps)\_2TX

CSE [AV]

2412MHz

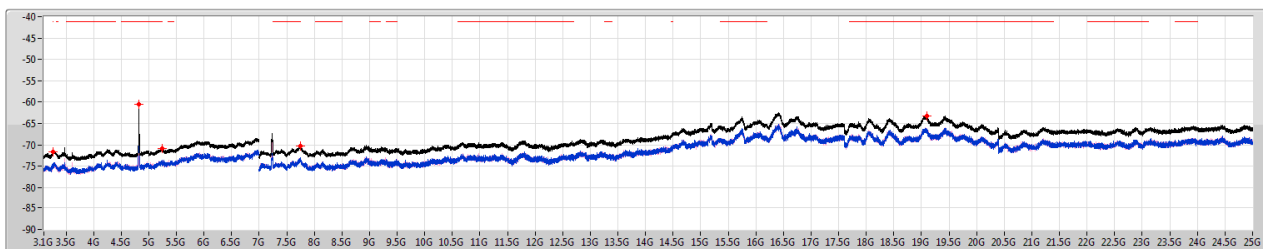

Limit.AV

Sum.AV

Port.1

Port.2

F-Start(Hz)	F-Stop(Hz)	RBW(Hz)	Type	Freq(Hz)	Psum(dBm)	P1(dBm)	P2(dBm)
3.1G	4G	1M	AV	3.2647G	-71.72	-75.02	-74.45
4G	5G	1M	AV	4.824G	-60.53	-67.57	-61.49
5G	7G	1M	AV	5.249G	-70.90	-73.54	-74.52
7G	8G	1M	AV	7.747G	-70.26	-73.54	-73.01
8G	25G	1M	AV	19.09197G	-63.23	-66.38	-66.10



2.4-2.4835GHz\_802.11g\_Nss1,(6Mbps)\_2TX

CSE [PK]

2437MHz

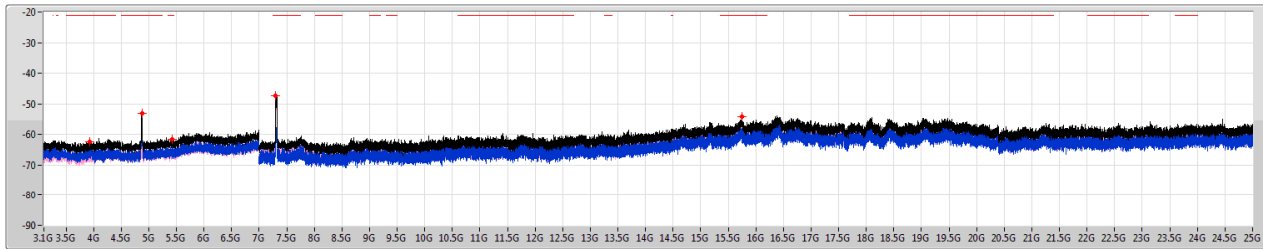

F-Start(Hz)	F-Stop(Hz)	RBW(Hz)	Type	Freq(Hz)	Psum(dBm)	P1(dBm)	P2(dBm)
3.1G	4G	1M	PK	3.92935G	-62.44	-65.15	-65.77
4G	5G	1M	PK	4.8755G	-52.96	-53.43	-62.88
5G	7G	1M	PK	5.4245G	-61.53	-64.01	-65.15
7G	8G	1M	PK	7.3G	-47.47	-61.58	-47.64
8G	25G	1M	PK	15.74616G	-54.22	-58.13	-56.48

2.4-2.4835GHz\_802.11g\_Nss1,(6Mbps)\_2TX

CSE [AV]

2437MHz

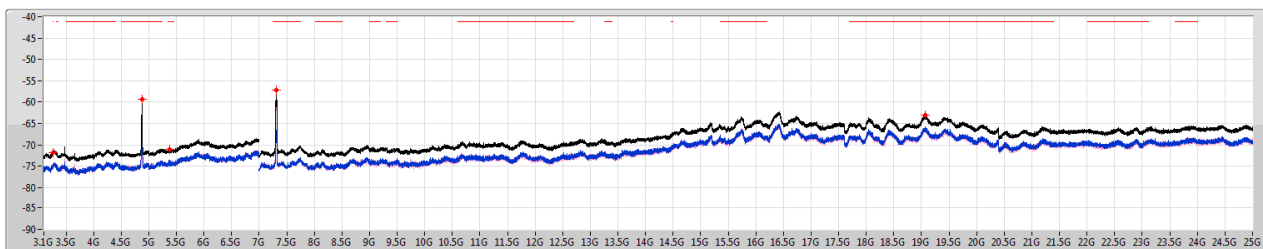

F-Start(Hz)	F-Stop(Hz)	RBW(Hz)	Type	Freq(Hz)	Psum(dBm)	P1(dBm)	P2(dBm)
3.1G	4G	1M	AV	3.2665G	-71.82	-74.97	-74.69
4G	5G	1M	AV	4.874G	-59.27	-63.85	-61.13
5G	7G	1M	AV	5.3865G	-71.00	-74.14	-73.88
7G	8G	1M	AV	7.3095G	-57.15	-67.12	-57.61
8G	25G	1M	AV	19.06913G	-63.02	-65.77	-66.31





2.4-2.4835GHz\_802.11g\_Nss1,(6Mbps)\_2TX

CSE [PK]

2462MHz

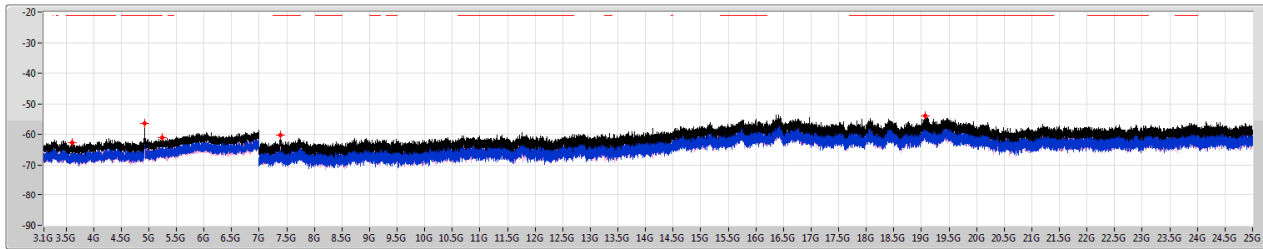

Limit.PK

Sum.PK

Port.1

Port.2

F-Start(Hz)	F-Stop(Hz)	RBW(Hz)	Type	Freq(Hz)	Psum(dBm)	P1(dBm)	P2(dBm)
3.1G	4G	1M	PK	3.6166G	-62.65	-65.57	-65.75
4G	5G	1M	PK	4.9245G	-56.48	-61.08	-58.33
5G	7G	1M	PK	5.245G	-63.03	-63.00	-64.29
7G	8G	1M	PK	7.388G	-60.19	-67.11	-61.18
8G	25G	1M	PK	19.06899G	-53.81	-57.04	-56.62

2.4-2.4835GHz\_802.11g\_Nss1,(6Mbps)\_2TX

CSE [AV]

2462MHz

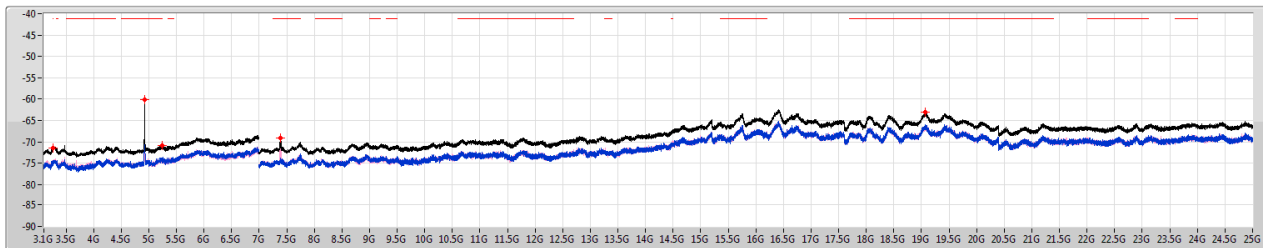

Limit.AV

Sum.AV

Port.1

Port.2

F-Start(Hz)	F-Stop(Hz)	RBW(Hz)	Type	Freq(Hz)	Psum(dBm)	P1(dBm)	P2(dBm)
3.1G	4G	1M	AV	3.26065G	-71.54	-74.55	-74.55
4G	5G	1M	AV	4.924G	-60.12	-68.75	-60.76
5G	7G	1M	AV	5.2475G	-70.91	-73.79	-74.65
7G	8G	1M	AV	7.3855G	-69.15	-73.83	-70.96
8G	25G	1M	AV	19.067G	-63.09	-66.17	-66.03



2.4-2.4835GHz\_802.11ax HEW20\_Nss1,(MCS0)\_2TX

CSE [PK]

2412MHz

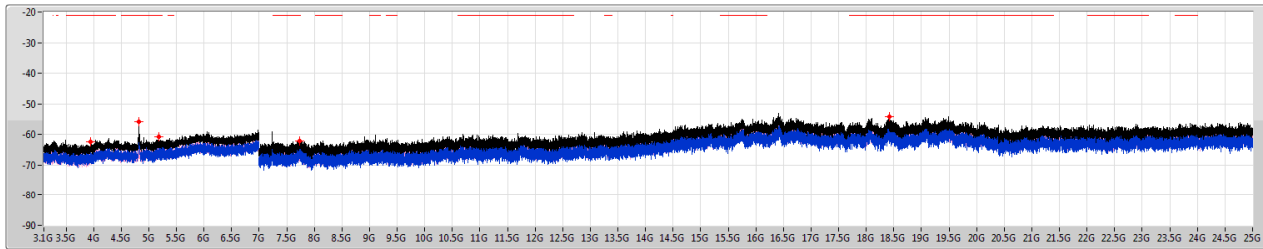

F-Start(Hz)	F-Stop(Hz)	RBW(Hz)	Type	Freq(Hz)	Psum(dBm)	P1(dBm)	P2(dBm)
3.1G	4G	1M	PK	3.9415G	-62.51	-66.19	-64.94
4G	5G	1M	PK	4.8245G	-55.78	-59.84	-57.95
5G	7G	1M	PK	5.1855G	-60.80	-65.72	-62.49
7G	8G	1M	PK	7.737G	-61.99	-65.24	-64.78
8G	25G	1M	PK	18.41197G	-54.20	-56.19	-58.54

2.4-2.4835GHz\_802.11ax HEW20\_Nss1,(MCS0)\_2TX

CSE [AV]

2412MHz

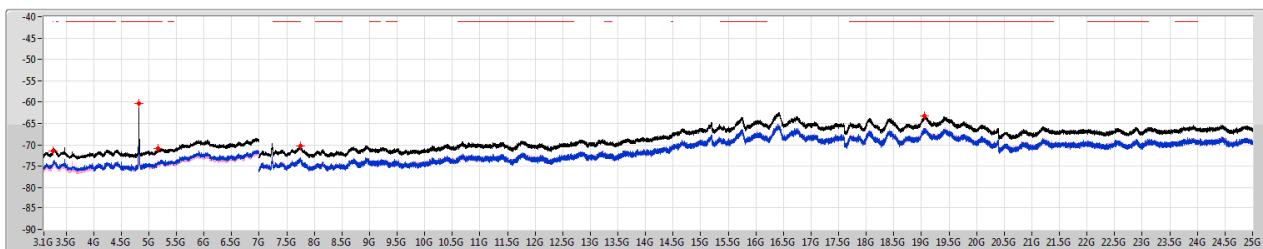

F-Start(Hz)	F-Stop(Hz)	RBW(Hz)	Type	Freq(Hz)	Psum(dBm)	P1(dBm)	P2(dBm)
3.1G	4G	1M	AV	3.2665G	-71.40	-74.41	-74.41
4G	5G	1M	AV	4.824G	-60.27	-67.93	-61.09
5G	7G	1M	AV	5.1665G	-70.85	-74.12	-73.62
7G	8G	1M	AV	7.7415G	-70.23	-73.24	-73.24
8G	25G	1M	AV	19.05159G	-63.26	-66.27	-66.27



2.4-2.4835GHz\_802.11ax HEW20\_Nss1,(MCS0)\_2TX

CSE [PK]

2437MHz

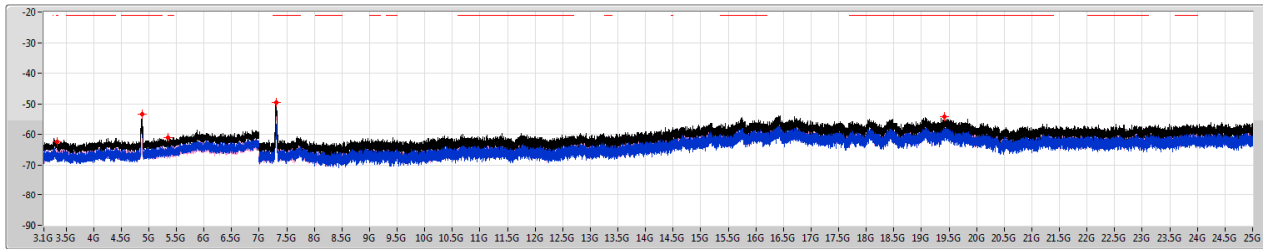

F-Start(Hz)	F-Stop(Hz)	RBW(Hz)	Type	Freq(Hz)	Psum(dBm)	P1(dBm)	P2(dBm)
3.1G	4G	1M	PK	3.3349G	-62.46	-65.91	-65.08
4G	5G	1M	PK	4.8745G	-53.34	-55.46	-57.46
5G	7G	1M	PK	5.3925G	-61.08	-63.70	-64.51
7G	8G	1M	PK	7.3115G	-49.66	-57.00	-50.55
8G	25G	1M	PK	19.41019G	-54.30	-57.56	-57.08

2.4-2.4835GHz\_802.11ax HEW20\_Nss1,(MCS0)\_2TX

CSE [AV]

2437MHz

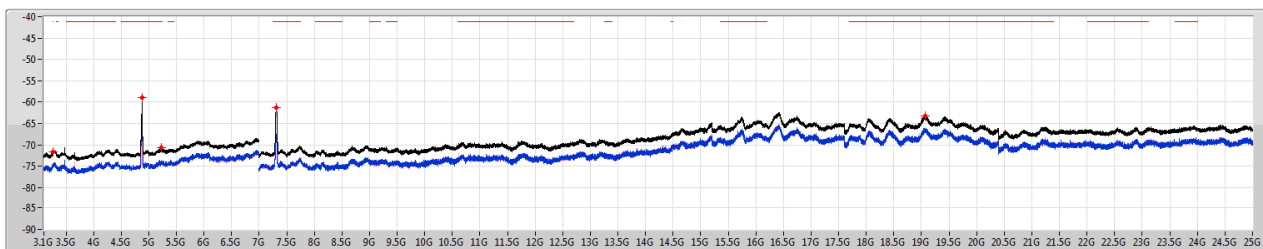

F-Start(Hz)	F-Stop(Hz)	RBW(Hz)	Type	Freq(Hz)	Psum(dBm)	P1(dBm)	P2(dBm)
3.1G	4G	1M	AV	3.262G	-71.64	-74.79	-74.52
4G	5G	1M	AV	4.874G	-59.03	-63.78	-60.80
5G	7G	1M	AV	5.222G	-70.71	-73.85	-73.60
7G	8G	1M	AV	7.306G	-61.25	-68.12	-62.25
8G	25G	1M	AV	19.07338G	-63.23	-66.76	-65.78



# Unwanted Conducted Emissions into Restricted Frequency Bands(3.1G~25GHz) - SC Module

## Appendix D.3

2.4-2.4835GHz\_802.11ax HEW20\_Nss1,(MCS0)\_2TX

CSE [PK]

2462MHz

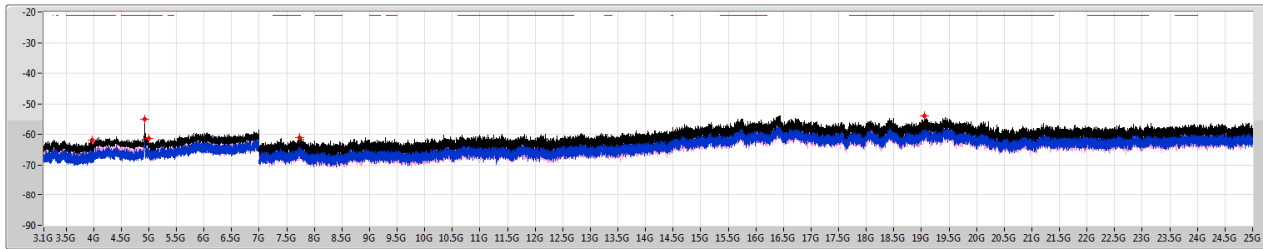

Limit.PK

Sum.PK

Port.1

Port.2

F-Start(Hz)	F-Stop(Hz)	RBW(Hz)	Type	Freq(Hz)	Psum(dBm)	P1(dBm)	P2(dBm)
3.1G	4G	1M	PK	3.97705G	-61.96	-64.53	-65.45
4G	5G	1M	PK	4.9245G	-54.95	-59.06	-57.09
5G	7G	1M	PK	5.004G	-61.24	-63.52	-65.39
7G	8G	1M	PK	7.734G	-61.07	-63.27	-65.07
8G	25G	1M	PK	19.0585G	-53.95	-56.20	-57.88

2.4-2.4835GHz\_802.11ax HEW20\_Nss1,(MCS0)\_2TX

CSE [AV]

2462MHz

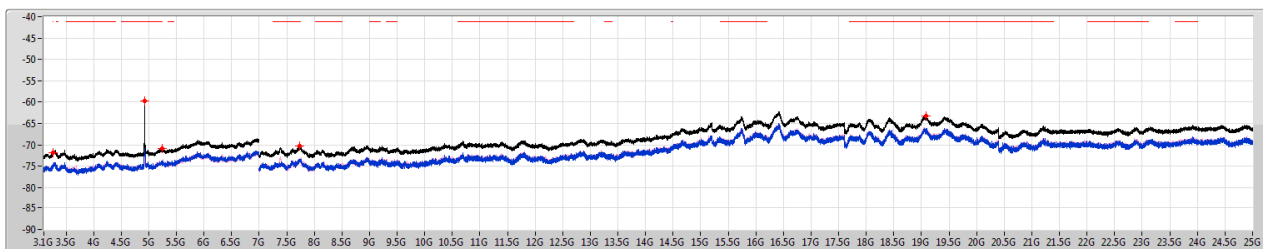

Limit.AV

Sum.AV

Port.1

Port.2

F-Start(Hz)	F-Stop(Hz)	RBW(Hz)	Type	Freq(Hz)	Psum(dBm)	P1(dBm)	P2(dBm)
3.1G	4G	1M	AV	3.26155G	-71.79	-74.53	-75.09
4G	5G	1M	AV	4.924G	-59.67	-68.48	-60.28
5G	7G	1M	AV	5.246G	-70.92	-74.06	-73.80
7G	8G	1M	AV	7.74G	-70.34	-73.44	-73.36
8G	25G	1M	AV	19.07763G	-63.26	-66.34	-66.20



**Unwanted Conducted Emissions into Restricted  
Frequency Bands (30M~1GHz) - ST M.2, PCIe Module**

**Appendix D.4**

**Summary**

Mode	Result	F-Start (Hz)	F-Stop (Hz)	Type	Freq (Hz)	DG (dBi)	P1 (dBm)	P2 (dBm)	Psum (dBm)	GRF (dB)	EIRP (dBm)	Limit (dBm)	Margin (dB)
2.4-2.4835GHz	-	-	-	-	-	-	-	-	-	-	-	-	-
802.11ax HEW20_Nss1,(MCS0)_2TX-OFDMA	Pass	30M	1G	PK	74.57M	5.41	-80.27	-82.77	-78.33	4.7	-68.22	-55.20	-13.02

DG = Directional Gain ; PX=Port X; Psum=P1+P2+...PX

**Result**

Mode	Result	F-Start (Hz)	F-Stop (Hz)	Type	Freq (Hz)	DG (dBi)	P1 (dBm)	P2 (dBm)	Psum (dBm)	GRF (dB)	EIRP (dBm)	Limit (dBm)	Margin (dB)
802.11ax HEW20_Nss1,(MCS0)_2TX-OFDMA	-	-	-	-	-	-	-	-	-	-	-	-	-
2437MHz	Pass	30M	1G	PK	74.57M	5.41	-80.27	-82.77	-78.33	4.7	-68.22	-55.20	-13.02

DG = Directional Gain ; PX=Port X; Psum=P1+P2+...PX



2.4-2.4835GHz\_802.11ax HEW20\_Nss1,(MCS0)\_2TX

CSE Other [PK]

2437MHz

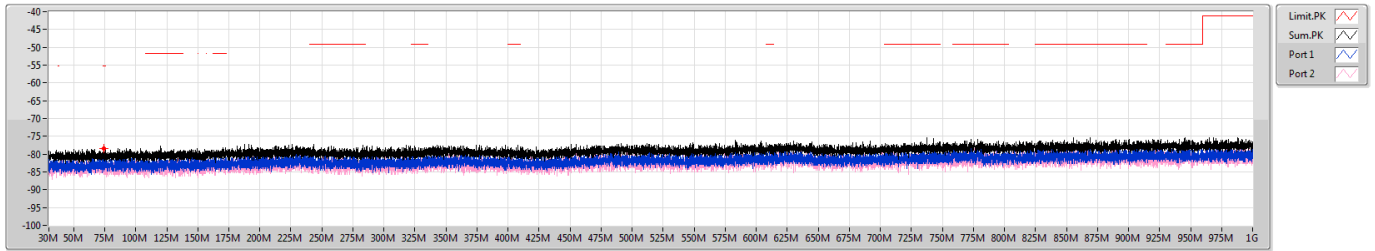

F-Start(Hz)	F-Stop(Hz)	RBW(Hz)	Type	Freq(Hz)	Psum(dBm)	P1(dBm)	P2(dBm)
30M	1G	100k	PK	74.57M	-78.33	-80.27	-82.77



**Unwanted Conducted Emissions into Restricted  
Frequency Bands (1G~3.1GHz) - ST M.2, PCIe Module**

**Appendix D.5**

**Summary**

Mode	Result	F-Start (Hz)	F-Stop (Hz)	Type	Freq (Hz)	DG (dBi)	P1 (dBm)	P2 (dBm)	Psum (dBm)	EIRP (dBm)	Limit (dBm)	Margin (dB)
2.4-2.4835GHz	-	-	-	-	-	-	-	-	-	-	-	-
802.11b_Nss1,(1Mbps)_2TX	Pass	2.31G	2.39G	AV	2.39G	5.41	-52.43	-52.62	-49.51	-44.10	-41.20	-2.90

DG = Directional Gain ; PX=Port X; Psum=P1+P2+...PX

**Result**

Mode	Result	F-Start (Hz)	F-Stop (Hz)	Type	Freq (Hz)	DG (dBi)	P1 (dBm)	P2 (dBm)	Psum (dBm)	EIRP (dBm)	Limit (dBm)	Margin (dB)
802.11b_Nss1,(1Mbps)_2TX	-	-	-	-	-	-	-	-	-	-	-	-
2412MHz	Pass	1G	2.31G	AV	2.31G	5.41	-61.78	-59.74	-57.63	-52.22	-41.20	-11.02
2412MHz	Pass	2.31G	2.39G	AV	2.39G	5.41	-52.43	-52.62	-49.51	-44.10	-41.20	-2.90
2412MHz	Pass	2.4835G	2.5G	AV	2.48829G	5.41	-58.30	-56.36	-54.21	-48.80	-41.20	-7.60
2412MHz	Pass	2.5G	3.1G	AV	2.5033G	5.41	-59.38	-57.53	-55.35	-49.94	-41.20	-8.74
2412MHz	Pass	1G	2.31G	PK	2.31G	5.41	-52.28	-49.78	-47.84	-42.43	-21.20	-21.23
2412MHz	Pass	2.31G	2.39G	PK	2.38948G	5.41	-43.74	-42.19	-39.89	-34.48	-21.20	-13.28
2412MHz	Pass	2.4835G	2.5G	PK	2.4875G	5.41	-49.49	-44.58	-43.36	-37.95	-21.20	-16.75
2412MHz	Pass	2.5G	3.1G	PK	2.503G	5.41	-52.33	-46.69	-45.64	-40.23	-21.20	-19.03

DG = Directional Gain ; PX=Port X; Psum=P1+P2+...PX



2.4-2.4835GHz\_802.11b\_Nss1,(1Mbps)\_2TX

CSE Bandedge [PK]

2412MHz

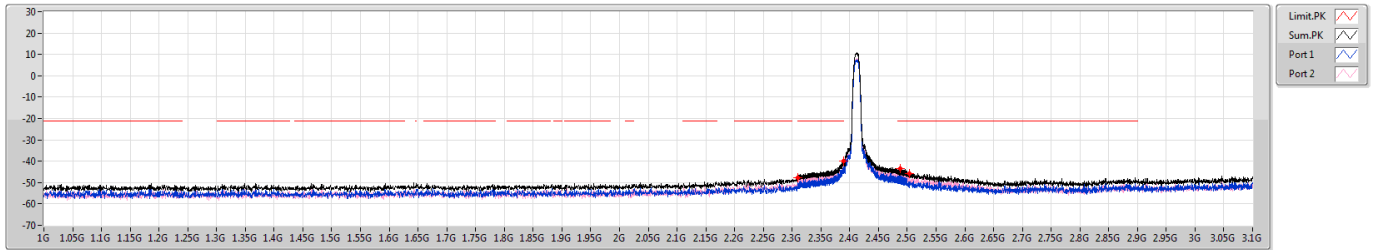

F-Start(Hz)	F-Stop(Hz)	RBW(Hz)	Type	Freq(Hz)	Psum(dBm)	P1(dBm)	P2(dBm)
1G	2.31G	1M	PK	2.31G	-47.84	-52.28	-49.78
2.31G	2.39G	1M	PK	2.38948G	-39.89	-43.74	-42.19
2.4835G	2.5G	1M	PK	2.4875G	-43.36	-49.49	-44.58
2.5G	3.1G	1M	PK	2.503G	-45.64	-52.33	-46.69

2.4-2.4835GHz\_802.11b\_Nss1,(1Mbps)\_2TX

CSE Bandedge [AV]

2412MHz

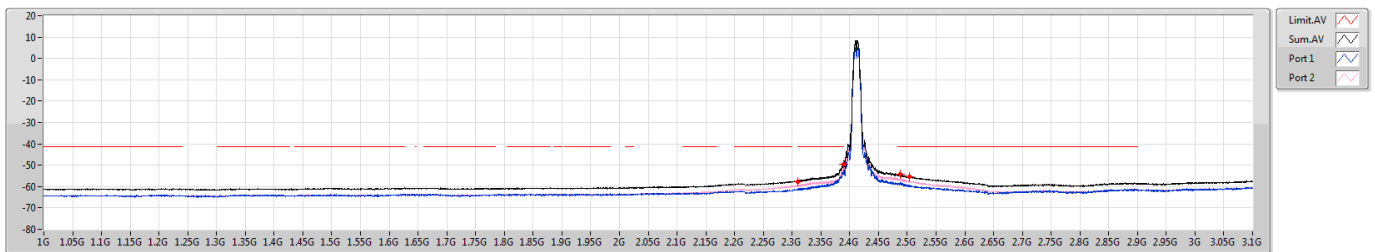

F-Start(Hz)	F-Stop(Hz)	RBW(Hz)	Type	Freq(Hz)	Psum(dBm)	P1(dBm)	P2(dBm)
1G	2.31G	1M	AV	2.31G	-57.63	-61.78	-59.74
2.31G	2.39G	1M	AV	2.39G	-49.51	-52.43	-52.62
2.4835G	2.5G	1M	AV	2.48829G	-54.21	-58.30	-56.36
2.5G	3.1G	1M	AV	2.5035G	-55.35	-59.38	-57.53





**Unwanted Conducted Emissions into Restricted Frequency Bands(3.1G~25GHz) - ST M.2, PCIe Module**

**Appendix D.6**

**Summary**

Mode	Result	F-Start (Hz)	F-Stop (Hz)	Type	Freq (Hz)	DG (dBi)	P1 (dBm)	P2 (dBm)	Psum (dBm)	EIRP (dBm)	Limit (dBm)	Margin (dB)
2.4-2.4835GHz	-	-	-	-	-	-	-	-	-	-	-	-
802.11b_Nss1,(1Mbps)_2TX	Pass	4G	5G	AV	4.824G	5.41	-53.09	-64.96	-52.82	-47.41	-41.20	-6.21

DG = Directional Gain ; PX=Port X; Psum=P1+P2+...PX

**Result**

Mode	Result	F-Start (Hz)	F-Stop (Hz)	Type	Freq (Hz)	DG (dBi)	P1 (dBm)	P2 (dBm)	Psum (dBm)	EIRP (dBm)	Limit (dBm)	Margin (dB)
802.11b_Nss1,(1Mbps)_2TX	-	-	-	-	-	-	-	-	-	-	-	-
2412MHz	Pass	3.1G	4G	AV	3.61795G	5.41	-75.87	-73.88	-71.75	-66.34	-41.20	-25.14
2412MHz	Pass	4G	5G	AV	4.824G	5.41	-53.09	-64.96	-52.82	-47.41	-41.20	-6.21
2412MHz	Pass	5G	7G	AV	5.242G	5.41	-73.73	-74.24	-70.97	-65.56	-41.20	-24.36
2412MHz	Pass	7G	8G	AV	7.744G	5.41	-73.42	-73.42	-70.41	-65.00	-41.20	-23.80
2412MHz	Pass	8G	25G	AV	19.42772G	5.41	-66.80	-66.26	-63.51	-58.10	-41.20	-16.90
2412MHz	Pass	3.1G	4G	PK	3.26425G	5.41	-64.87	-64.52	-61.68	-56.27	-21.20	-35.07
2412MHz	Pass	4G	5G	PK	4.8245G	5.41	-52.18	-60.35	-51.56	-46.15	-21.20	-24.95
2412MHz	Pass	5G	7G	PK	5.1905G	5.41	-63.57	-64.94	-61.19	-55.78	-21.20	-34.58
2412MHz	Pass	7G	8G	PK	7.7155G	5.41	-63.21	-64.07	-60.61	-55.20	-21.20	-34.00
2412MHz	Pass	8G	25G	PK	19.43303G	5.41	-57.56	-56.27	-53.86	-48.45	-21.20	-27.25

DG = Directional Gain ; PX=Port X; Psum=P1+P2+...PX



2.4-2.4835GHz\_802.11b\_Nss1,(1Mbps)\_2TX

CSE [PK]

2412MHz

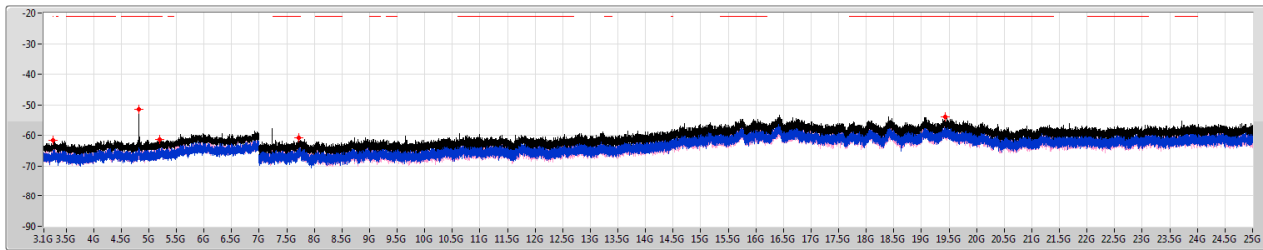

F-Start(Hz)	F-Stop(Hz)	RBW(Hz)	Type	Freq(Hz)	Psum(dBm)	P1(dBm)	P2(dBm)
3.1G	4G	1M	PK	3.26425G	-61.68	-64.87	-64.52
4G	5G	1M	PK	4.8245G	-51.56	-52.18	-60.35
5G	7G	1M	PK	5.1905G	-61.19	-63.57	-64.94
7G	8G	1M	PK	7.7155G	-60.61	-63.21	-64.07
8G	25G	1M	PK	19.43303G	-53.86	-57.56	-56.27

2.4-2.4835GHz\_802.11b\_Nss1,(1Mbps)\_2TX

CSE [AV]

2412MHz

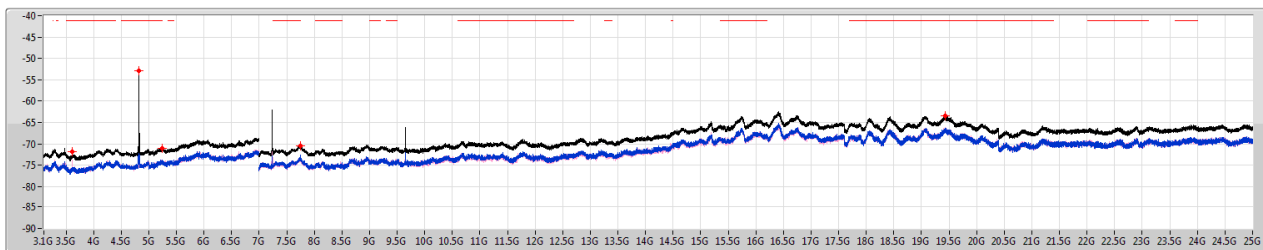

F-Start(Hz)	F-Stop(Hz)	RBW(Hz)	Type	Freq(Hz)	Psum(dBm)	P1(dBm)	P2(dBm)
3.1G	4G	1M	AV	3.61795G	-71.75	-75.87	-73.88
4G	5G	1M	AV	4.824G	-52.82	-53.09	-64.96
5G	7G	1M	AV	5.242G	-70.97	-73.73	-74.24
7G	8G	1M	AV	7.744G	-70.41	-73.42	-73.42
8G	25G	1M	AV	19.42772G	-63.51	-66.80	-66.26



SC Module

Unwanted Emissions (Below 1GHz)

Modulation	11b	Test Freq. (MHz)	2437
Polarization	Horizontal		

Test By : Sean Yu      Temperature(°C): 25      Humidity(%): 61

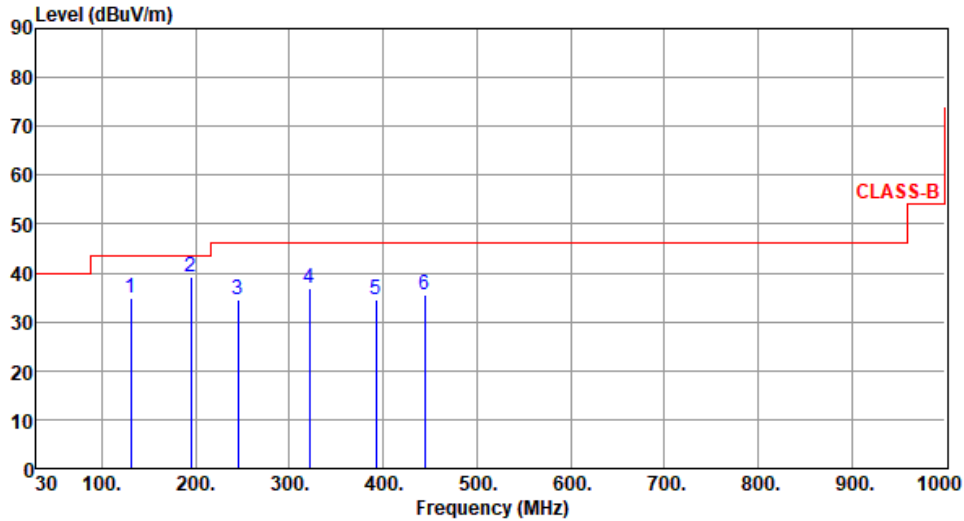

	Freq. MHz	Emission level dBuV/m	Limit dBuV/m	Margin dB	SA reading dBuV	Factor dB/m	Remark	ANT High cm	Turn Table deg
1	130.88	34.89	43.50	-8.61	45.00	-10.11	Peak	---	---
2	194.90	39.17	43.50	-4.33	50.85	-11.68	Peak	---	---
3	245.34	34.44	46.00	-11.56	44.61	-10.17	Peak	---	---
4	321.00	36.82	46.00	-9.18	44.34	-7.52	Peak	---	---
5	392.78	34.48	46.00	-11.52	40.20	-5.72	Peak	---	---
6	444.19	35.55	46.00	-10.45	39.91	-4.36	Peak	---	---

Note 1: Emission Level (dBuV/m) = SA Reading (dBuV) + Factor\* (dB/m)

\*Factor includes antenna factor , cable loss and amplifier gain

Note 2: Margin (dB) = Emission level (dBuV/m) – Limit (dBuV/m).

Note 3: All spurious emissions below 30MHz are more than 20 dB below the limit.



**Unwanted Radiated Emissions into Restricted Frequency Bands**

**Appendix D.7**

<b>Modulation</b>	11b	<b>Test Freq. (MHz)</b>	2437
<b>Polarization</b>	Vertical		

Test By : Sean Yu      Temperature(°C): 25      Humidity(%): 61

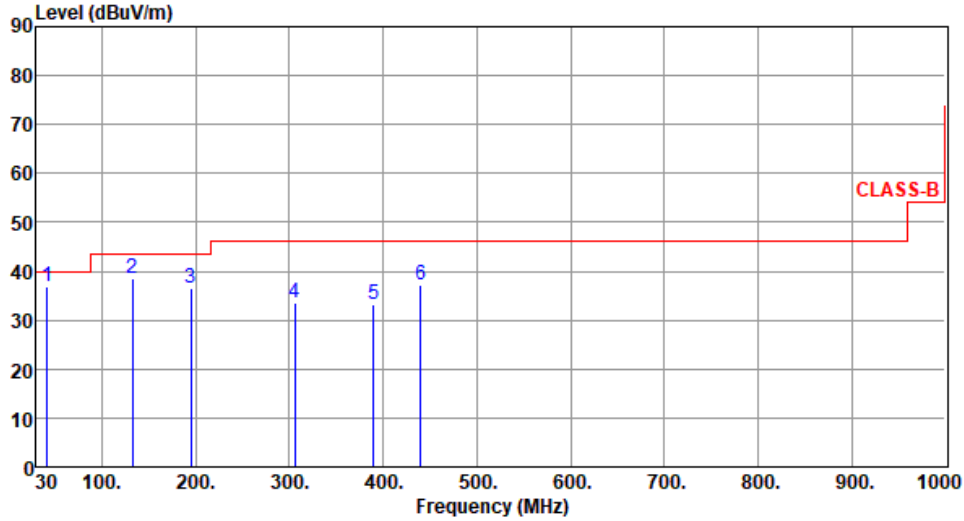

	Freq. MHz	Emission level dBuV/m	Limit dBuV/m	Margin dB	SA reading dBuV	Factor dB/m	Remark	ANT High cm	Turn Table deg
1	41.64	36.85	40.00	-3.15	45.51	-8.66	QP	100	166
2	132.82	38.38	43.50	-5.12	48.52	-10.14	Peak	---	---
3	194.90	36.64	43.50	-6.86	48.32	-11.68	Peak	---	---
4	305.48	33.40	46.00	-12.60	41.45	-8.05	Peak	---	---
5	389.87	33.07	46.00	-12.93	38.86	-5.79	Peak	---	---
6	440.31	37.29	46.00	-8.71	41.72	-4.43	Peak	---	---

Note 1: Emission Level (dBuV/m) = SA Reading (dBuV) + Factor\* (dB/m)

\*Factor includes antenna factor , cable loss and amplifier gain

Note 2: Margin (dB) = Emission level (dBuV/m) – Limit (dBuV/m).

Note 3: All spurious emissions below 30MHz are more than 20 dB below the limit.



**Unwanted Emission (Above 1GHz) for 11b**

<b>Modulation</b>	11b	<b>Test Freq. (MHz)</b>	2412						
<b>Polarization</b>	Horizontal								
Test By :Paul Lin      Temperature(°C):25      Humidity(%):62									
	Freq. MHz	Emission level dBuV/m	Limit dBuV/m	Margin dB	SA reading dBuV	Factor dB/m	Remark	ANT High cm	Turn Table deg
1	4000.00	50.81	54.00	-3.19	53.05	-2.24	Average	288	130
2	4000.00	55.06	74.00	-18.94	57.30	-2.24	Peak	288	130
3	4824.00	31.75	54.00	-22.25	32.28	-0.53	Average	100	112
4	4824.00	44.60	74.00	-29.40	45.13	-0.53	Peak	100	112
5	12060.00	42.55	54.00	-11.45	36.18	6.37	Average	100	177
6	12060.00	55.83	74.00	-18.17	49.46	6.37	Peak	100	177

Note 1: Emission Level (dBuV/m) = SA Reading (dBuV) + Factor\* (dB/m)  
 \*Factor includes antenna factor , cable loss and amplifier gain  
 Note 2: Margin (dB) = Emission level (dBuV/m) – Limit (dBuV/m).



**Unwanted Radiated Emissions into Restricted Frequency Bands**

**Appendix D.7**

<b>Modulation</b>	11b		<b>Test Freq. (MHz)</b>	2412					
<b>Polarization</b>	Vertical								
Test By : Paul Lin		Temperature(°C): 25		Humidity(%): 62					
	Freq.	Emission level	Limit	Margin	SA reading	Factor	Remark	ANT High	Turn Table
	MHz	dBuV/m	dBuV/m	dB	dBuV	dB/m		cm	deg
1	4000.00	44.61	54.00	-9.39	46.85	-2.24	Average	306	201
2	4000.00	51.25	74.00	-22.75	53.49	-2.24	Peak	306	201
3	4824.00	31.49	54.00	-22.51	32.02	-0.53	Average	100	128
4	4824.00	44.58	74.00	-29.42	45.11	-0.53	Peak	100	128
5	12060.00	42.33	54.00	-11.67	35.96	6.37	Average	100	196
6	12060.00	55.52	74.00	-18.48	49.15	6.37	Peak	100	196

Note 1: Emission Level (dBUV/m) = SA Reading (dBUV) + Factor\* (dB/m)  
 \*Factor includes antenna factor , cable loss and amplifier gain  
 Note 2: Margin (dB) = Emission level (dBUV/m) – Limit (dBUV/m).



**Unwanted Radiated Emissions into Restricted Frequency Bands**

**Appendix D.7**

<b>Modulation</b>	11b	<b>Test Freq. (MHz)</b>	2437
<b>Polarization</b>	Horizontal		

Test By : Sean Yu      Temperature(°C): 25      Humidity(%): 62

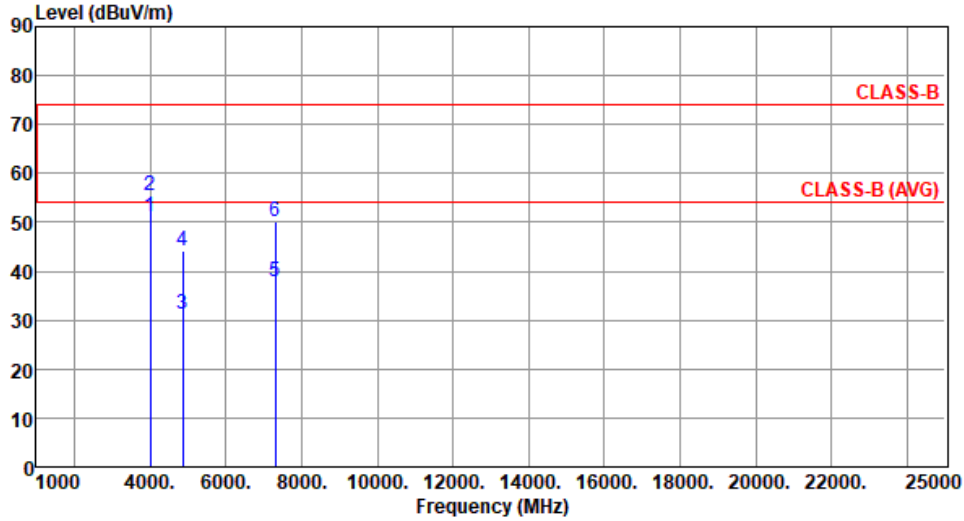

	Freq. MHz	Emission level dBuV/m	Limit dBuV/m	Margin dB	SA reading dBuV	Factor dB/m	Remark	ANT High cm	Turn Table deg
1	4000.00	50.99	54.00	-3.01	53.23	-2.24	Average	287	133
2	4000.00	55.45	74.00	-18.55	57.69	-2.24	Peak	287	133
3	4874.00	31.12	54.00	-22.88	31.66	-0.54	Average	100	208
4	4874.00	44.06	74.00	-29.94	44.60	-0.54	Peak	100	208
5	7311.00	37.99	54.00	-16.01	32.77	5.22	Average	100	182
6	7311.00	50.29	74.00	-23.71	45.07	5.22	Peak	100	182

Note 1: Emission Level (dBuV/m) = SA Reading (dBuV) + Factor\* (dB/m)

\*Factor includes antenna factor , cable loss and amplifier gain

Note 2: Margin (dB) = Emission level (dBuV/m) – Limit (dBuV/m).



**Unwanted Radiated Emissions into Restricted Frequency Bands**

<b>Modulation</b>	11b	<b>Test Freq. (MHz)</b>	2437																																																																																																																										
<b>Polarization</b>	Vertical																																																																																																																												
Test By : Sean Yu      Temperature(°C): 25      Humidity(%): 62																																																																																																																													
	<table border="1"> <thead> <tr> <th>1</th> <th>2</th> <th>3</th> <th>4</th> <th>5</th> <th>6</th> </tr> </thead> <tbody> <tr> <td>4000.00</td> <td>4000.00</td> <td>4874.00</td> <td>4874.00</td> <td>7311.00</td> <td>7311.00</td> </tr> <tr> <td>44.72</td> <td>51.43</td> <td>31.24</td> <td>44.28</td> <td>38.08</td> <td>51.09</td> </tr> <tr> <td>54.00</td> <td>74.00</td> <td>54.00</td> <td>74.00</td> <td>54.00</td> <td>74.00</td> </tr> <tr> <td>-9.28</td> <td>-22.57</td> <td>-22.76</td> <td>-29.72</td> <td>-15.92</td> <td>-22.91</td> </tr> <tr> <td>46.96</td> <td>53.67</td> <td>31.78</td> <td>44.82</td> <td>32.86</td> <td>45.87</td> </tr> <tr> <td>-2.24</td> <td>-2.24</td> <td>-0.54</td> <td>-0.54</td> <td>5.22</td> <td>5.22</td> </tr> <tr> <td>Average</td> <td>Peak</td> <td>Average</td> <td>Peak</td> <td>Average</td> <td>Peak</td> </tr> <tr> <td>305</td> <td>305</td> <td>100</td> <td>100</td> <td>100</td> <td>100</td> </tr> <tr> <td>206</td> <td>206</td> <td>225</td> <td>225</td> <td>91</td> <td>91</td> </tr> </tbody> </table>	1	2	3	4	5	6	4000.00	4000.00	4874.00	4874.00	7311.00	7311.00	44.72	51.43	31.24	44.28	38.08	51.09	54.00	74.00	54.00	74.00	54.00	74.00	-9.28	-22.57	-22.76	-29.72	-15.92	-22.91	46.96	53.67	31.78	44.82	32.86	45.87	-2.24	-2.24	-0.54	-0.54	5.22	5.22	Average	Peak	Average	Peak	Average	Peak	305	305	100	100	100	100	206	206	225	225	91	91	<table border="1"> <thead> <tr> <th>Freq. MHz</th> <th>Emission level dBuV/m</th> <th>Limit dBuV/m</th> <th>Margin dB</th> <th>SA reading dBuV</th> <th>Factor dB/m</th> <th>Remark</th> <th>ANT High cm</th> <th>Turn Table deg</th> </tr> </thead> <tbody> <tr> <td>4000.00</td> <td>44.72</td> <td>54.00</td> <td>-9.28</td> <td>46.96</td> <td>-2.24</td> <td>Average</td> <td>305</td> <td>206</td> </tr> <tr> <td>4000.00</td> <td>51.43</td> <td>74.00</td> <td>-22.57</td> <td>53.67</td> <td>-2.24</td> <td>Peak</td> <td>305</td> <td>206</td> </tr> <tr> <td>4874.00</td> <td>31.24</td> <td>54.00</td> <td>-22.76</td> <td>31.78</td> <td>-0.54</td> <td>Average</td> <td>100</td> <td>225</td> </tr> <tr> <td>4874.00</td> <td>44.28</td> <td>74.00</td> <td>-29.72</td> <td>44.82</td> <td>-0.54</td> <td>Peak</td> <td>100</td> <td>225</td> </tr> <tr> <td>7311.00</td> <td>38.08</td> <td>54.00</td> <td>-15.92</td> <td>32.86</td> <td>5.22</td> <td>Average</td> <td>100</td> <td>91</td> </tr> <tr> <td>7311.00</td> <td>51.09</td> <td>74.00</td> <td>-22.91</td> <td>45.87</td> <td>5.22</td> <td>Peak</td> <td>100</td> <td>91</td> </tr> </tbody> </table>	Freq. MHz	Emission level dBuV/m	Limit dBuV/m	Margin dB	SA reading dBuV	Factor dB/m	Remark	ANT High cm	Turn Table deg	4000.00	44.72	54.00	-9.28	46.96	-2.24	Average	305	206	4000.00	51.43	74.00	-22.57	53.67	-2.24	Peak	305	206	4874.00	31.24	54.00	-22.76	31.78	-0.54	Average	100	225	4874.00	44.28	74.00	-29.72	44.82	-0.54	Peak	100	225	7311.00	38.08	54.00	-15.92	32.86	5.22	Average	100	91	7311.00	51.09	74.00	-22.91	45.87	5.22	Peak	100	91
1	2	3	4	5	6																																																																																																																								
4000.00	4000.00	4874.00	4874.00	7311.00	7311.00																																																																																																																								
44.72	51.43	31.24	44.28	38.08	51.09																																																																																																																								
54.00	74.00	54.00	74.00	54.00	74.00																																																																																																																								
-9.28	-22.57	-22.76	-29.72	-15.92	-22.91																																																																																																																								
46.96	53.67	31.78	44.82	32.86	45.87																																																																																																																								
-2.24	-2.24	-0.54	-0.54	5.22	5.22																																																																																																																								
Average	Peak	Average	Peak	Average	Peak																																																																																																																								
305	305	100	100	100	100																																																																																																																								
206	206	225	225	91	91																																																																																																																								
Freq. MHz	Emission level dBuV/m	Limit dBuV/m	Margin dB	SA reading dBuV	Factor dB/m	Remark	ANT High cm	Turn Table deg																																																																																																																					
4000.00	44.72	54.00	-9.28	46.96	-2.24	Average	305	206																																																																																																																					
4000.00	51.43	74.00	-22.57	53.67	-2.24	Peak	305	206																																																																																																																					
4874.00	31.24	54.00	-22.76	31.78	-0.54	Average	100	225																																																																																																																					
4874.00	44.28	74.00	-29.72	44.82	-0.54	Peak	100	225																																																																																																																					
7311.00	38.08	54.00	-15.92	32.86	5.22	Average	100	91																																																																																																																					
7311.00	51.09	74.00	-22.91	45.87	5.22	Peak	100	91																																																																																																																					
Note 1: Emission Level (dBuV/m) = SA Reading (dBuV) + Factor* (dB/m) *Factor includes antenna factor , cable loss and amplifier gain Note 2: Margin (dB) = Emission level (dBuV/m) – Limit (dBuV/m).																																																																																																																													





**Unwanted Radiated Emissions into Restricted Frequency Bands**

**Appendix D.7**

<b>Modulation</b>	11b	<b>Test Freq. (MHz)</b>	2462																																																																																																																																			
<b>Polarization</b>	Horizontal																																																																																																																																					
Test By : Paul Lin      Temperature(°C):25      Humidity(%):62																																																																																																																																						
	<table border="1"> <thead> <tr> <th>1</th> <th>2</th> <th>3</th> <th>4</th> <th>5</th> <th>6</th> </tr> </thead> <tbody> <tr> <td>4000.00</td> <td>4000.00</td> <td>4924.00</td> <td>4924.00</td> <td>7386.00</td> <td>7386.00</td> </tr> <tr> <td>50.89</td> <td>55.23</td> <td>31.78</td> <td>44.52</td> <td>37.51</td> <td>50.39</td> </tr> <tr> <td>54.00</td> <td>74.00</td> <td>54.00</td> <td>74.00</td> <td>54.00</td> <td>74.00</td> </tr> <tr> <td>-3.11</td> <td>-18.77</td> <td>-22.22</td> <td>-29.48</td> <td>-16.49</td> <td>-23.61</td> </tr> <tr> <td>53.13</td> <td>57.47</td> <td>32.29</td> <td>45.03</td> <td>32.44</td> <td>45.32</td> </tr> <tr> <td>-2.24</td> <td>-2.24</td> <td>-0.51</td> <td>-0.51</td> <td>5.07</td> <td>5.07</td> </tr> <tr> <td>Average</td> <td>Peak</td> <td>Average</td> <td>Peak</td> <td>Average</td> <td>Peak</td> </tr> <tr> <td>286</td> <td>286</td> <td>100</td> <td>100</td> <td>100</td> <td>100</td> </tr> <tr> <td>129</td> <td>129</td> <td>150</td> <td>150</td> <td>168</td> <td>168</td> </tr> </tbody> </table>	1	2	3	4	5	6	4000.00	4000.00	4924.00	4924.00	7386.00	7386.00	50.89	55.23	31.78	44.52	37.51	50.39	54.00	74.00	54.00	74.00	54.00	74.00	-3.11	-18.77	-22.22	-29.48	-16.49	-23.61	53.13	57.47	32.29	45.03	32.44	45.32	-2.24	-2.24	-0.51	-0.51	5.07	5.07	Average	Peak	Average	Peak	Average	Peak	286	286	100	100	100	100	129	129	150	150	168	168	<table border="1"> <thead> <tr> <th>Freq.</th> <th>Emission level</th> <th>Limit</th> <th>Margin</th> <th>SA reading</th> <th>Factor</th> <th>Remark</th> <th>ANT High cm</th> <th>Turn Table deg</th> </tr> <tr> <th>MHz</th> <th>dBuV/m</th> <th>dBuV/m</th> <th>dB</th> <th>dBuV</th> <th>dB/m</th> <th></th> <th></th> <th></th> </tr> </thead> <tbody> <tr> <td>4000.00</td> <td>50.89</td> <td>54.00</td> <td>-3.11</td> <td>53.13</td> <td>-2.24</td> <td>Average</td> <td>286</td> <td>129</td> </tr> <tr> <td>4000.00</td> <td>55.23</td> <td>74.00</td> <td>-18.77</td> <td>57.47</td> <td>-2.24</td> <td>Peak</td> <td>286</td> <td>129</td> </tr> <tr> <td>4924.00</td> <td>31.78</td> <td>54.00</td> <td>-22.22</td> <td>32.29</td> <td>-0.51</td> <td>Average</td> <td>100</td> <td>150</td> </tr> <tr> <td>4924.00</td> <td>44.52</td> <td>74.00</td> <td>-29.48</td> <td>45.03</td> <td>-0.51</td> <td>Peak</td> <td>100</td> <td>150</td> </tr> <tr> <td>7386.00</td> <td>37.51</td> <td>54.00</td> <td>-16.49</td> <td>32.44</td> <td>5.07</td> <td>Average</td> <td>100</td> <td>168</td> </tr> <tr> <td>7386.00</td> <td>50.39</td> <td>74.00</td> <td>-23.61</td> <td>45.32</td> <td>5.07</td> <td>Peak</td> <td>100</td> <td>168</td> </tr> </tbody> </table>	Freq.	Emission level	Limit	Margin	SA reading	Factor	Remark	ANT High cm	Turn Table deg	MHz	dBuV/m	dBuV/m	dB	dBuV	dB/m				4000.00	50.89	54.00	-3.11	53.13	-2.24	Average	286	129	4000.00	55.23	74.00	-18.77	57.47	-2.24	Peak	286	129	4924.00	31.78	54.00	-22.22	32.29	-0.51	Average	100	150	4924.00	44.52	74.00	-29.48	45.03	-0.51	Peak	100	150	7386.00	37.51	54.00	-16.49	32.44	5.07	Average	100	168	7386.00	50.39	74.00	-23.61	45.32	5.07	Peak	100	168
1	2	3	4	5	6																																																																																																																																	
4000.00	4000.00	4924.00	4924.00	7386.00	7386.00																																																																																																																																	
50.89	55.23	31.78	44.52	37.51	50.39																																																																																																																																	
54.00	74.00	54.00	74.00	54.00	74.00																																																																																																																																	
-3.11	-18.77	-22.22	-29.48	-16.49	-23.61																																																																																																																																	
53.13	57.47	32.29	45.03	32.44	45.32																																																																																																																																	
-2.24	-2.24	-0.51	-0.51	5.07	5.07																																																																																																																																	
Average	Peak	Average	Peak	Average	Peak																																																																																																																																	
286	286	100	100	100	100																																																																																																																																	
129	129	150	150	168	168																																																																																																																																	
Freq.	Emission level	Limit	Margin	SA reading	Factor	Remark	ANT High cm	Turn Table deg																																																																																																																														
MHz	dBuV/m	dBuV/m	dB	dBuV	dB/m																																																																																																																																	
4000.00	50.89	54.00	-3.11	53.13	-2.24	Average	286	129																																																																																																																														
4000.00	55.23	74.00	-18.77	57.47	-2.24	Peak	286	129																																																																																																																														
4924.00	31.78	54.00	-22.22	32.29	-0.51	Average	100	150																																																																																																																														
4924.00	44.52	74.00	-29.48	45.03	-0.51	Peak	100	150																																																																																																																														
7386.00	37.51	54.00	-16.49	32.44	5.07	Average	100	168																																																																																																																														
7386.00	50.39	74.00	-23.61	45.32	5.07	Peak	100	168																																																																																																																														
Note 1: Emission Level (dBuV/m) = SA Reading (dBuV) + Factor* (dB/m) *Factor includes antenna factor , cable loss and amplifier gain Note 2: Margin (dB) = Emission level (dBuV/m) – Limit (dBuV/m).																																																																																																																																						



**Unwanted Radiated Emissions into Restricted Frequency Bands**

**Appendix D.7**

<b>Modulation</b>	11b	<b>Test Freq. (MHz)</b>	2462																																																																																																																										
<b>Polarization</b>	Vertical																																																																																																																												
Test By : Paul Lin      Temperature(°C):25      Humidity(%):62																																																																																																																													
	<table border="1"> <thead> <tr> <th>1</th> <th>2</th> <th>3</th> <th>4</th> <th>5</th> <th>6</th> </tr> </thead> <tbody> <tr> <td>4000.00</td> <td>4000.00</td> <td>4924.00</td> <td>4924.00</td> <td>7386.00</td> <td>7386.00</td> </tr> <tr> <td>44.57</td> <td>51.19</td> <td>31.51</td> <td>44.65</td> <td>37.87</td> <td>50.43</td> </tr> <tr> <td>54.00</td> <td>74.00</td> <td>54.00</td> <td>74.00</td> <td>54.00</td> <td>74.00</td> </tr> <tr> <td>-9.43</td> <td>-22.81</td> <td>-22.49</td> <td>-29.35</td> <td>-16.13</td> <td>-23.57</td> </tr> <tr> <td>46.81</td> <td>53.43</td> <td>32.02</td> <td>45.16</td> <td>32.80</td> <td>45.36</td> </tr> <tr> <td>-2.24</td> <td>-2.24</td> <td>-0.51</td> <td>-0.51</td> <td>5.07</td> <td>5.07</td> </tr> <tr> <td>Average</td> <td>Peak</td> <td>Average</td> <td>Peak</td> <td>Average</td> <td>Peak</td> </tr> <tr> <td>305</td> <td>305</td> <td>100</td> <td>100</td> <td>100</td> <td>100</td> </tr> <tr> <td>205</td> <td>205</td> <td>146</td> <td>146</td> <td>109</td> <td>109</td> </tr> </tbody> </table>	1	2	3	4	5	6	4000.00	4000.00	4924.00	4924.00	7386.00	7386.00	44.57	51.19	31.51	44.65	37.87	50.43	54.00	74.00	54.00	74.00	54.00	74.00	-9.43	-22.81	-22.49	-29.35	-16.13	-23.57	46.81	53.43	32.02	45.16	32.80	45.36	-2.24	-2.24	-0.51	-0.51	5.07	5.07	Average	Peak	Average	Peak	Average	Peak	305	305	100	100	100	100	205	205	146	146	109	109	<table border="1"> <thead> <tr> <th>Freq. MHz</th> <th>Emission level dBuV/m</th> <th>Limit dBuV/m</th> <th>Margin dB</th> <th>SA reading dBuV</th> <th>Factor dB/m</th> <th>Remark</th> <th>ANT High cm</th> <th>Turn Table deg</th> </tr> </thead> <tbody> <tr> <td>4000.00</td> <td>44.57</td> <td>54.00</td> <td>-9.43</td> <td>46.81</td> <td>-2.24</td> <td>Average</td> <td>305</td> <td>205</td> </tr> <tr> <td>4000.00</td> <td>51.19</td> <td>74.00</td> <td>-22.81</td> <td>53.43</td> <td>-2.24</td> <td>Peak</td> <td>305</td> <td>205</td> </tr> <tr> <td>4924.00</td> <td>31.51</td> <td>54.00</td> <td>-22.49</td> <td>32.02</td> <td>-0.51</td> <td>Average</td> <td>100</td> <td>146</td> </tr> <tr> <td>4924.00</td> <td>44.65</td> <td>74.00</td> <td>-29.35</td> <td>45.16</td> <td>-0.51</td> <td>Peak</td> <td>100</td> <td>146</td> </tr> <tr> <td>7386.00</td> <td>37.87</td> <td>54.00</td> <td>-16.13</td> <td>32.80</td> <td>5.07</td> <td>Average</td> <td>100</td> <td>109</td> </tr> <tr> <td>7386.00</td> <td>50.43</td> <td>74.00</td> <td>-23.57</td> <td>45.36</td> <td>5.07</td> <td>Peak</td> <td>100</td> <td>109</td> </tr> </tbody> </table>	Freq. MHz	Emission level dBuV/m	Limit dBuV/m	Margin dB	SA reading dBuV	Factor dB/m	Remark	ANT High cm	Turn Table deg	4000.00	44.57	54.00	-9.43	46.81	-2.24	Average	305	205	4000.00	51.19	74.00	-22.81	53.43	-2.24	Peak	305	205	4924.00	31.51	54.00	-22.49	32.02	-0.51	Average	100	146	4924.00	44.65	74.00	-29.35	45.16	-0.51	Peak	100	146	7386.00	37.87	54.00	-16.13	32.80	5.07	Average	100	109	7386.00	50.43	74.00	-23.57	45.36	5.07	Peak	100	109
1	2	3	4	5	6																																																																																																																								
4000.00	4000.00	4924.00	4924.00	7386.00	7386.00																																																																																																																								
44.57	51.19	31.51	44.65	37.87	50.43																																																																																																																								
54.00	74.00	54.00	74.00	54.00	74.00																																																																																																																								
-9.43	-22.81	-22.49	-29.35	-16.13	-23.57																																																																																																																								
46.81	53.43	32.02	45.16	32.80	45.36																																																																																																																								
-2.24	-2.24	-0.51	-0.51	5.07	5.07																																																																																																																								
Average	Peak	Average	Peak	Average	Peak																																																																																																																								
305	305	100	100	100	100																																																																																																																								
205	205	146	146	109	109																																																																																																																								
Freq. MHz	Emission level dBuV/m	Limit dBuV/m	Margin dB	SA reading dBuV	Factor dB/m	Remark	ANT High cm	Turn Table deg																																																																																																																					
4000.00	44.57	54.00	-9.43	46.81	-2.24	Average	305	205																																																																																																																					
4000.00	51.19	74.00	-22.81	53.43	-2.24	Peak	305	205																																																																																																																					
4924.00	31.51	54.00	-22.49	32.02	-0.51	Average	100	146																																																																																																																					
4924.00	44.65	74.00	-29.35	45.16	-0.51	Peak	100	146																																																																																																																					
7386.00	37.87	54.00	-16.13	32.80	5.07	Average	100	109																																																																																																																					
7386.00	50.43	74.00	-23.57	45.36	5.07	Peak	100	109																																																																																																																					
Note 1: Emission Level (dBuV/m) = SA Reading (dBuV) + Factor* (dB/m) *Factor includes antenna factor , cable loss and amplifier gain Note 2: Margin (dB) = Emission level (dBuV/m) – Limit (dBuV/m).																																																																																																																													



Unwanted Emissions (Above 1GHz) for 11g

Modulation	11g	Test Freq. (MHz)	2412						
Polarization	Horizontal								
Test By :Paul Lin      Temperature(°C):25      Humidity(%):62									
	Freq. MHz	Emission level dBuV/m	Limit dBuV/m	Margin dB	SA reading dBuV	Factor dB/m	Remark	ANT High cm	Turn Table deg
1	4000.00	50.97	54.00	-3.03	53.21	-2.24	Average	288	134
2	4000.00	55.41	74.00	-18.59	57.65	-2.24	Peak	288	134
3	4824.00	31.72	54.00	-22.28	32.25	-0.53	Average	100	111
4	4824.00	44.85	74.00	-29.15	45.38	-0.53	Peak	100	111
5	12060.00	42.54	54.00	-11.46	36.17	6.37	Average	100	134
6	12060.00	55.94	74.00	-18.06	49.57	6.37	Peak	100	134

Note 1: Emission Level (dBuV/m) = SA Reading (dBuV) + Factor\* (dB/m)  
 \*Factor includes antenna factor , cable loss and amplifier gain  
 Note 2: Margin (dB) = Emission level (dBuV/m) – Limit (dBuV/m).



**Unwanted Radiated Emissions into Restricted Frequency Bands**

**Appendix D.7**

<b>Modulation</b>	11g	<b>Test Freq. (MHz)</b>	2412																																																																																																																										
<b>Polarization</b>	Vertical																																																																																																																												
Test By : Paul Lin      Temperature(°C): 25      Humidity(%): 62																																																																																																																													
	<table border="1"> <thead> <tr> <th>1</th> <th>2</th> <th>3</th> <th>4</th> <th>5</th> <th>6</th> </tr> </thead> <tbody> <tr> <td>4000.00</td> <td>4000.00</td> <td>4824.00</td> <td>4824.00</td> <td>12060.00</td> <td>12060.00</td> </tr> <tr> <td>45.06</td> <td>51.55</td> <td>31.61</td> <td>44.84</td> <td>42.71</td> <td>56.20</td> </tr> <tr> <td>54.00</td> <td>74.00</td> <td>54.00</td> <td>74.00</td> <td>54.00</td> <td>74.00</td> </tr> <tr> <td>-8.94</td> <td>-22.45</td> <td>-22.39</td> <td>-29.16</td> <td>-11.29</td> <td>-17.80</td> </tr> <tr> <td>47.30</td> <td>53.79</td> <td>32.14</td> <td>45.37</td> <td>36.34</td> <td>49.83</td> </tr> <tr> <td>-2.24</td> <td>-2.24</td> <td>-0.53</td> <td>-0.53</td> <td>6.37</td> <td>6.37</td> </tr> <tr> <td>Average</td> <td>Peak</td> <td>Average</td> <td>Peak</td> <td>Average</td> <td>Peak</td> </tr> <tr> <td>306</td> <td>306</td> <td>100</td> <td>100</td> <td>100</td> <td>100</td> </tr> <tr> <td>202</td> <td>202</td> <td>129</td> <td>129</td> <td>184</td> <td>184</td> </tr> </tbody> </table>	1	2	3	4	5	6	4000.00	4000.00	4824.00	4824.00	12060.00	12060.00	45.06	51.55	31.61	44.84	42.71	56.20	54.00	74.00	54.00	74.00	54.00	74.00	-8.94	-22.45	-22.39	-29.16	-11.29	-17.80	47.30	53.79	32.14	45.37	36.34	49.83	-2.24	-2.24	-0.53	-0.53	6.37	6.37	Average	Peak	Average	Peak	Average	Peak	306	306	100	100	100	100	202	202	129	129	184	184	<table border="1"> <thead> <tr> <th>Freq. MHz</th> <th>Emission level dBuV/m</th> <th>Limit dBuV/m</th> <th>Margin dB</th> <th>SA reading dBuV</th> <th>Factor dB/m</th> <th>Remark</th> <th>ANT High cm</th> <th>Turn Table deg</th> </tr> </thead> <tbody> <tr> <td>4000.00</td> <td>45.06</td> <td>54.00</td> <td>-8.94</td> <td>47.30</td> <td>-2.24</td> <td>Average</td> <td>306</td> <td>202</td> </tr> <tr> <td>4000.00</td> <td>51.55</td> <td>74.00</td> <td>-22.45</td> <td>53.79</td> <td>-2.24</td> <td>Peak</td> <td>306</td> <td>202</td> </tr> <tr> <td>4824.00</td> <td>31.61</td> <td>54.00</td> <td>-22.39</td> <td>32.14</td> <td>-0.53</td> <td>Average</td> <td>100</td> <td>129</td> </tr> <tr> <td>4824.00</td> <td>44.84</td> <td>74.00</td> <td>-29.16</td> <td>45.37</td> <td>-0.53</td> <td>Peak</td> <td>100</td> <td>129</td> </tr> <tr> <td>12060.00</td> <td>42.71</td> <td>54.00</td> <td>-11.29</td> <td>36.34</td> <td>6.37</td> <td>Average</td> <td>100</td> <td>184</td> </tr> <tr> <td>12060.00</td> <td>56.20</td> <td>74.00</td> <td>-17.80</td> <td>49.83</td> <td>6.37</td> <td>Peak</td> <td>100</td> <td>184</td> </tr> </tbody> </table>	Freq. MHz	Emission level dBuV/m	Limit dBuV/m	Margin dB	SA reading dBuV	Factor dB/m	Remark	ANT High cm	Turn Table deg	4000.00	45.06	54.00	-8.94	47.30	-2.24	Average	306	202	4000.00	51.55	74.00	-22.45	53.79	-2.24	Peak	306	202	4824.00	31.61	54.00	-22.39	32.14	-0.53	Average	100	129	4824.00	44.84	74.00	-29.16	45.37	-0.53	Peak	100	129	12060.00	42.71	54.00	-11.29	36.34	6.37	Average	100	184	12060.00	56.20	74.00	-17.80	49.83	6.37	Peak	100	184
1	2	3	4	5	6																																																																																																																								
4000.00	4000.00	4824.00	4824.00	12060.00	12060.00																																																																																																																								
45.06	51.55	31.61	44.84	42.71	56.20																																																																																																																								
54.00	74.00	54.00	74.00	54.00	74.00																																																																																																																								
-8.94	-22.45	-22.39	-29.16	-11.29	-17.80																																																																																																																								
47.30	53.79	32.14	45.37	36.34	49.83																																																																																																																								
-2.24	-2.24	-0.53	-0.53	6.37	6.37																																																																																																																								
Average	Peak	Average	Peak	Average	Peak																																																																																																																								
306	306	100	100	100	100																																																																																																																								
202	202	129	129	184	184																																																																																																																								
Freq. MHz	Emission level dBuV/m	Limit dBuV/m	Margin dB	SA reading dBuV	Factor dB/m	Remark	ANT High cm	Turn Table deg																																																																																																																					
4000.00	45.06	54.00	-8.94	47.30	-2.24	Average	306	202																																																																																																																					
4000.00	51.55	74.00	-22.45	53.79	-2.24	Peak	306	202																																																																																																																					
4824.00	31.61	54.00	-22.39	32.14	-0.53	Average	100	129																																																																																																																					
4824.00	44.84	74.00	-29.16	45.37	-0.53	Peak	100	129																																																																																																																					
12060.00	42.71	54.00	-11.29	36.34	6.37	Average	100	184																																																																																																																					
12060.00	56.20	74.00	-17.80	49.83	6.37	Peak	100	184																																																																																																																					
Note 1: Emission Level (dBuV/m) = SA Reading (dBuV) + Factor* (dB/m) *Factor includes antenna factor , cable loss and amplifier gain Note 2: Margin (dB) = Emission level (dBuV/m) – Limit (dBuV/m).																																																																																																																													



**Unwanted Radiated Emissions into Restricted Frequency Bands**

**Appendix D.7**

<b>Modulation</b>	11g	<b>Test Freq. (MHz)</b>	2437																																																																																																																										
<b>Polarization</b>	Horizontal																																																																																																																												
Test By : Paul Lin      Temperature(°C): 25      Humidity(%): 62																																																																																																																													
	<table border="1"> <thead> <tr> <th>1</th> <th>2</th> <th>3</th> <th>4</th> <th>5</th> <th>6</th> </tr> </thead> <tbody> <tr> <td>4000.00</td> <td>4000.00</td> <td>4874.00</td> <td>4874.00</td> <td>7311.00</td> <td>7311.00</td> </tr> <tr> <td>50.95</td> <td>55.34</td> <td>31.34</td> <td>45.07</td> <td>38.03</td> <td>50.74</td> </tr> <tr> <td>54.00</td> <td>74.00</td> <td>54.00</td> <td>74.00</td> <td>54.00</td> <td>74.00</td> </tr> <tr> <td>-3.05</td> <td>-18.66</td> <td>-22.66</td> <td>-28.93</td> <td>-15.97</td> <td>-23.26</td> </tr> <tr> <td>53.19</td> <td>57.58</td> <td>31.88</td> <td>45.61</td> <td>32.81</td> <td>45.52</td> </tr> <tr> <td>-2.24</td> <td>-2.24</td> <td>-0.54</td> <td>-0.54</td> <td>5.22</td> <td>5.22</td> </tr> <tr> <td>Average</td> <td>Peak</td> <td>Average</td> <td>Peak</td> <td>Average</td> <td>Peak</td> </tr> <tr> <td>286</td> <td>286</td> <td>100</td> <td>100</td> <td>100</td> <td>100</td> </tr> <tr> <td>134</td> <td>134</td> <td>122</td> <td>122</td> <td>189</td> <td>189</td> </tr> </tbody> </table>	1	2	3	4	5	6	4000.00	4000.00	4874.00	4874.00	7311.00	7311.00	50.95	55.34	31.34	45.07	38.03	50.74	54.00	74.00	54.00	74.00	54.00	74.00	-3.05	-18.66	-22.66	-28.93	-15.97	-23.26	53.19	57.58	31.88	45.61	32.81	45.52	-2.24	-2.24	-0.54	-0.54	5.22	5.22	Average	Peak	Average	Peak	Average	Peak	286	286	100	100	100	100	134	134	122	122	189	189	<table border="1"> <thead> <tr> <th>Freq. MHz</th> <th>Emission level dBuV/m</th> <th>Limit dBuV/m</th> <th>Margin dB</th> <th>SA reading dBuV</th> <th>Factor dB/m</th> <th>Remark</th> <th>ANT High cm</th> <th>Turn Table deg</th> </tr> </thead> <tbody> <tr> <td>4000.00</td> <td>50.95</td> <td>54.00</td> <td>-3.05</td> <td>53.19</td> <td>-2.24</td> <td>Average</td> <td>286</td> <td>134</td> </tr> <tr> <td>4000.00</td> <td>55.34</td> <td>74.00</td> <td>-18.66</td> <td>57.58</td> <td>-2.24</td> <td>Peak</td> <td>286</td> <td>134</td> </tr> <tr> <td>4874.00</td> <td>31.34</td> <td>54.00</td> <td>-22.66</td> <td>31.88</td> <td>-0.54</td> <td>Average</td> <td>100</td> <td>122</td> </tr> <tr> <td>4874.00</td> <td>45.07</td> <td>74.00</td> <td>-28.93</td> <td>45.61</td> <td>-0.54</td> <td>Peak</td> <td>100</td> <td>122</td> </tr> <tr> <td>7311.00</td> <td>38.03</td> <td>54.00</td> <td>-15.97</td> <td>32.81</td> <td>5.22</td> <td>Average</td> <td>100</td> <td>189</td> </tr> <tr> <td>7311.00</td> <td>50.74</td> <td>74.00</td> <td>-23.26</td> <td>45.52</td> <td>5.22</td> <td>Peak</td> <td>100</td> <td>189</td> </tr> </tbody> </table>	Freq. MHz	Emission level dBuV/m	Limit dBuV/m	Margin dB	SA reading dBuV	Factor dB/m	Remark	ANT High cm	Turn Table deg	4000.00	50.95	54.00	-3.05	53.19	-2.24	Average	286	134	4000.00	55.34	74.00	-18.66	57.58	-2.24	Peak	286	134	4874.00	31.34	54.00	-22.66	31.88	-0.54	Average	100	122	4874.00	45.07	74.00	-28.93	45.61	-0.54	Peak	100	122	7311.00	38.03	54.00	-15.97	32.81	5.22	Average	100	189	7311.00	50.74	74.00	-23.26	45.52	5.22	Peak	100	189
1	2	3	4	5	6																																																																																																																								
4000.00	4000.00	4874.00	4874.00	7311.00	7311.00																																																																																																																								
50.95	55.34	31.34	45.07	38.03	50.74																																																																																																																								
54.00	74.00	54.00	74.00	54.00	74.00																																																																																																																								
-3.05	-18.66	-22.66	-28.93	-15.97	-23.26																																																																																																																								
53.19	57.58	31.88	45.61	32.81	45.52																																																																																																																								
-2.24	-2.24	-0.54	-0.54	5.22	5.22																																																																																																																								
Average	Peak	Average	Peak	Average	Peak																																																																																																																								
286	286	100	100	100	100																																																																																																																								
134	134	122	122	189	189																																																																																																																								
Freq. MHz	Emission level dBuV/m	Limit dBuV/m	Margin dB	SA reading dBuV	Factor dB/m	Remark	ANT High cm	Turn Table deg																																																																																																																					
4000.00	50.95	54.00	-3.05	53.19	-2.24	Average	286	134																																																																																																																					
4000.00	55.34	74.00	-18.66	57.58	-2.24	Peak	286	134																																																																																																																					
4874.00	31.34	54.00	-22.66	31.88	-0.54	Average	100	122																																																																																																																					
4874.00	45.07	74.00	-28.93	45.61	-0.54	Peak	100	122																																																																																																																					
7311.00	38.03	54.00	-15.97	32.81	5.22	Average	100	189																																																																																																																					
7311.00	50.74	74.00	-23.26	45.52	5.22	Peak	100	189																																																																																																																					
Note 1: Emission Level (dBuV/m) = SA Reading (dBuV) + Factor* (dB/m) *Factor includes antenna factor , cable loss and amplifier gain Note 2: Margin (dB) = Emission level (dBuV/m) – Limit (dBuV/m).																																																																																																																													



**Unwanted Radiated Emissions into Restricted Frequency Bands**

**Appendix D.7**

<b>Modulation</b>	11g	<b>Test Freq. (MHz)</b>	2437																																																																																																																										
<b>Polarization</b>	Vertical																																																																																																																												
Test By : Paul Lin      Temperature(°C): 25      Humidity(%): 62																																																																																																																													
	<table border="1"> <thead> <tr> <th>1</th> <th>2</th> <th>3</th> <th>4</th> <th>5</th> <th>6</th> </tr> </thead> <tbody> <tr> <td>4000.00</td> <td>4000.00</td> <td>4874.00</td> <td>4874.00</td> <td>7311.00</td> <td>7311.00</td> </tr> <tr> <td>44.91</td> <td>51.38</td> <td>31.31</td> <td>44.61</td> <td>37.64</td> <td>51.14</td> </tr> <tr> <td>54.00</td> <td>74.00</td> <td>54.00</td> <td>74.00</td> <td>54.00</td> <td>74.00</td> </tr> <tr> <td>-9.09</td> <td>-22.62</td> <td>-22.69</td> <td>-29.39</td> <td>-16.36</td> <td>-22.86</td> </tr> <tr> <td>47.15</td> <td>53.62</td> <td>31.85</td> <td>45.15</td> <td>32.42</td> <td>45.92</td> </tr> <tr> <td>-2.24</td> <td>-2.24</td> <td>-0.54</td> <td>-0.54</td> <td>5.22</td> <td>5.22</td> </tr> <tr> <td>Average</td> <td>Peak</td> <td>Average</td> <td>Peak</td> <td>Average</td> <td>Peak</td> </tr> <tr> <td>306</td> <td>306</td> <td>100</td> <td>100</td> <td>100</td> <td>100</td> </tr> <tr> <td>204</td> <td>204</td> <td>105</td> <td>105</td> <td>173</td> <td>173</td> </tr> </tbody> </table>	1	2	3	4	5	6	4000.00	4000.00	4874.00	4874.00	7311.00	7311.00	44.91	51.38	31.31	44.61	37.64	51.14	54.00	74.00	54.00	74.00	54.00	74.00	-9.09	-22.62	-22.69	-29.39	-16.36	-22.86	47.15	53.62	31.85	45.15	32.42	45.92	-2.24	-2.24	-0.54	-0.54	5.22	5.22	Average	Peak	Average	Peak	Average	Peak	306	306	100	100	100	100	204	204	105	105	173	173	<table border="1"> <thead> <tr> <th>Freq. MHz</th> <th>Emission level dBuV/m</th> <th>Limit dBuV/m</th> <th>Margin dB</th> <th>SA reading dBuV</th> <th>Factor dB/m</th> <th>Remark</th> <th>ANT High cm</th> <th>Turn Table deg</th> </tr> </thead> <tbody> <tr> <td>4000.00</td> <td>44.91</td> <td>54.00</td> <td>-9.09</td> <td>47.15</td> <td>-2.24</td> <td>Average</td> <td>306</td> <td>204</td> </tr> <tr> <td>4000.00</td> <td>51.38</td> <td>74.00</td> <td>-22.62</td> <td>53.62</td> <td>-2.24</td> <td>Peak</td> <td>306</td> <td>204</td> </tr> <tr> <td>4874.00</td> <td>31.31</td> <td>54.00</td> <td>-22.69</td> <td>31.85</td> <td>-0.54</td> <td>Average</td> <td>100</td> <td>105</td> </tr> <tr> <td>4874.00</td> <td>44.61</td> <td>74.00</td> <td>-29.39</td> <td>45.15</td> <td>-0.54</td> <td>Peak</td> <td>100</td> <td>105</td> </tr> <tr> <td>7311.00</td> <td>37.64</td> <td>54.00</td> <td>-16.36</td> <td>32.42</td> <td>5.22</td> <td>Average</td> <td>100</td> <td>173</td> </tr> <tr> <td>7311.00</td> <td>51.14</td> <td>74.00</td> <td>-22.86</td> <td>45.92</td> <td>5.22</td> <td>Peak</td> <td>100</td> <td>173</td> </tr> </tbody> </table>	Freq. MHz	Emission level dBuV/m	Limit dBuV/m	Margin dB	SA reading dBuV	Factor dB/m	Remark	ANT High cm	Turn Table deg	4000.00	44.91	54.00	-9.09	47.15	-2.24	Average	306	204	4000.00	51.38	74.00	-22.62	53.62	-2.24	Peak	306	204	4874.00	31.31	54.00	-22.69	31.85	-0.54	Average	100	105	4874.00	44.61	74.00	-29.39	45.15	-0.54	Peak	100	105	7311.00	37.64	54.00	-16.36	32.42	5.22	Average	100	173	7311.00	51.14	74.00	-22.86	45.92	5.22	Peak	100	173
1	2	3	4	5	6																																																																																																																								
4000.00	4000.00	4874.00	4874.00	7311.00	7311.00																																																																																																																								
44.91	51.38	31.31	44.61	37.64	51.14																																																																																																																								
54.00	74.00	54.00	74.00	54.00	74.00																																																																																																																								
-9.09	-22.62	-22.69	-29.39	-16.36	-22.86																																																																																																																								
47.15	53.62	31.85	45.15	32.42	45.92																																																																																																																								
-2.24	-2.24	-0.54	-0.54	5.22	5.22																																																																																																																								
Average	Peak	Average	Peak	Average	Peak																																																																																																																								
306	306	100	100	100	100																																																																																																																								
204	204	105	105	173	173																																																																																																																								
Freq. MHz	Emission level dBuV/m	Limit dBuV/m	Margin dB	SA reading dBuV	Factor dB/m	Remark	ANT High cm	Turn Table deg																																																																																																																					
4000.00	44.91	54.00	-9.09	47.15	-2.24	Average	306	204																																																																																																																					
4000.00	51.38	74.00	-22.62	53.62	-2.24	Peak	306	204																																																																																																																					
4874.00	31.31	54.00	-22.69	31.85	-0.54	Average	100	105																																																																																																																					
4874.00	44.61	74.00	-29.39	45.15	-0.54	Peak	100	105																																																																																																																					
7311.00	37.64	54.00	-16.36	32.42	5.22	Average	100	173																																																																																																																					
7311.00	51.14	74.00	-22.86	45.92	5.22	Peak	100	173																																																																																																																					
Note 1: Emission Level (dBuV/m) = SA Reading (dBuV) + Factor* (dB/m) *Factor includes antenna factor , cable loss and amplifier gain Note 2: Margin (dB) = Emission level (dBuV/m) – Limit (dBuV/m).																																																																																																																													



**Unwanted Radiated Emissions into Restricted Frequency Bands**

**Appendix D.7**

<b>Modulation</b>	11g	<b>Test Freq. (MHz)</b>	2462																																																																																																																										
<b>Polarization</b>	Horizontal																																																																																																																												
Test By : Paul Lin      Temperature(°C): 25      Humidity(%): 62																																																																																																																													
	<table border="1"> <thead> <tr> <th>1</th> <th>2</th> <th>3</th> <th>4</th> <th>5</th> <th>6</th> </tr> </thead> <tbody> <tr> <td>4000.00</td> <td>4000.00</td> <td>4924.00</td> <td>4924.00</td> <td>7386.00</td> <td>7386.00</td> </tr> <tr> <td>50.87</td> <td>55.19</td> <td>31.63</td> <td>45.08</td> <td>37.51</td> <td>50.92</td> </tr> <tr> <td>54.00</td> <td>74.00</td> <td>54.00</td> <td>74.00</td> <td>54.00</td> <td>74.00</td> </tr> <tr> <td>-3.13</td> <td>-18.81</td> <td>-22.37</td> <td>-28.92</td> <td>-16.49</td> <td>-23.08</td> </tr> <tr> <td>53.11</td> <td>57.43</td> <td>32.14</td> <td>45.59</td> <td>32.44</td> <td>45.85</td> </tr> <tr> <td>-2.24</td> <td>-2.24</td> <td>-0.51</td> <td>-0.51</td> <td>5.07</td> <td>5.07</td> </tr> <tr> <td>Average</td> <td>Peak</td> <td>Average</td> <td>Peak</td> <td>Average</td> <td>Peak</td> </tr> <tr> <td>287</td> <td>287</td> <td>100</td> <td>100</td> <td>100</td> <td>100</td> </tr> <tr> <td>135</td> <td>135</td> <td>116</td> <td>116</td> <td>167</td> <td>167</td> </tr> </tbody> </table>	1	2	3	4	5	6	4000.00	4000.00	4924.00	4924.00	7386.00	7386.00	50.87	55.19	31.63	45.08	37.51	50.92	54.00	74.00	54.00	74.00	54.00	74.00	-3.13	-18.81	-22.37	-28.92	-16.49	-23.08	53.11	57.43	32.14	45.59	32.44	45.85	-2.24	-2.24	-0.51	-0.51	5.07	5.07	Average	Peak	Average	Peak	Average	Peak	287	287	100	100	100	100	135	135	116	116	167	167	<table border="1"> <thead> <tr> <th>Freq. MHz</th> <th>Emission level dBuV/m</th> <th>Limit dBuV/m</th> <th>Margin dB</th> <th>SA reading dBuV</th> <th>Factor dB/m</th> <th>Remark</th> <th>ANT High cm</th> <th>Turn Table deg</th> </tr> </thead> <tbody> <tr> <td>4000.00</td> <td>50.87</td> <td>54.00</td> <td>-3.13</td> <td>53.11</td> <td>-2.24</td> <td>Average</td> <td>287</td> <td>135</td> </tr> <tr> <td>4000.00</td> <td>55.19</td> <td>74.00</td> <td>-18.81</td> <td>57.43</td> <td>-2.24</td> <td>Peak</td> <td>287</td> <td>135</td> </tr> <tr> <td>4924.00</td> <td>31.63</td> <td>54.00</td> <td>-22.37</td> <td>32.14</td> <td>-0.51</td> <td>Average</td> <td>100</td> <td>116</td> </tr> <tr> <td>4924.00</td> <td>45.08</td> <td>74.00</td> <td>-28.92</td> <td>45.59</td> <td>-0.51</td> <td>Peak</td> <td>100</td> <td>116</td> </tr> <tr> <td>7386.00</td> <td>37.51</td> <td>54.00</td> <td>-16.49</td> <td>32.44</td> <td>5.07</td> <td>Average</td> <td>100</td> <td>167</td> </tr> <tr> <td>7386.00</td> <td>50.92</td> <td>74.00</td> <td>-23.08</td> <td>45.85</td> <td>5.07</td> <td>Peak</td> <td>100</td> <td>167</td> </tr> </tbody> </table>	Freq. MHz	Emission level dBuV/m	Limit dBuV/m	Margin dB	SA reading dBuV	Factor dB/m	Remark	ANT High cm	Turn Table deg	4000.00	50.87	54.00	-3.13	53.11	-2.24	Average	287	135	4000.00	55.19	74.00	-18.81	57.43	-2.24	Peak	287	135	4924.00	31.63	54.00	-22.37	32.14	-0.51	Average	100	116	4924.00	45.08	74.00	-28.92	45.59	-0.51	Peak	100	116	7386.00	37.51	54.00	-16.49	32.44	5.07	Average	100	167	7386.00	50.92	74.00	-23.08	45.85	5.07	Peak	100	167
1	2	3	4	5	6																																																																																																																								
4000.00	4000.00	4924.00	4924.00	7386.00	7386.00																																																																																																																								
50.87	55.19	31.63	45.08	37.51	50.92																																																																																																																								
54.00	74.00	54.00	74.00	54.00	74.00																																																																																																																								
-3.13	-18.81	-22.37	-28.92	-16.49	-23.08																																																																																																																								
53.11	57.43	32.14	45.59	32.44	45.85																																																																																																																								
-2.24	-2.24	-0.51	-0.51	5.07	5.07																																																																																																																								
Average	Peak	Average	Peak	Average	Peak																																																																																																																								
287	287	100	100	100	100																																																																																																																								
135	135	116	116	167	167																																																																																																																								
Freq. MHz	Emission level dBuV/m	Limit dBuV/m	Margin dB	SA reading dBuV	Factor dB/m	Remark	ANT High cm	Turn Table deg																																																																																																																					
4000.00	50.87	54.00	-3.13	53.11	-2.24	Average	287	135																																																																																																																					
4000.00	55.19	74.00	-18.81	57.43	-2.24	Peak	287	135																																																																																																																					
4924.00	31.63	54.00	-22.37	32.14	-0.51	Average	100	116																																																																																																																					
4924.00	45.08	74.00	-28.92	45.59	-0.51	Peak	100	116																																																																																																																					
7386.00	37.51	54.00	-16.49	32.44	5.07	Average	100	167																																																																																																																					
7386.00	50.92	74.00	-23.08	45.85	5.07	Peak	100	167																																																																																																																					
Note 1: Emission Level (dBuV/m) = SA Reading (dBuV) + Factor* (dB/m) *Factor includes antenna factor , cable loss and amplifier gain Note 2: Margin (dB) = Emission level (dBuV/m) – Limit (dBuV/m).																																																																																																																													



**Unwanted Radiated Emissions into Restricted Frequency Bands**

**Appendix D.7**

<b>Modulation</b>	11g	<b>Test Freq. (MHz)</b>	2462																																																																																																																										
<b>Polarization</b>	Vertical																																																																																																																												
Test By : Paul Lin      Temperature(°C): 25      Humidity(%): 62																																																																																																																													
	<table border="1"> <thead> <tr> <th>1</th> <th>2</th> <th>3</th> <th>4</th> <th>5</th> <th>6</th> </tr> </thead> <tbody> <tr> <td>4000.00</td> <td>4000.00</td> <td>4924.00</td> <td>4924.00</td> <td>7386.00</td> <td>7386.00</td> </tr> <tr> <td>44.76</td> <td>51.27</td> <td>31.57</td> <td>44.65</td> <td>37.57</td> <td>51.37</td> </tr> <tr> <td>54.00</td> <td>74.00</td> <td>54.00</td> <td>74.00</td> <td>54.00</td> <td>74.00</td> </tr> <tr> <td>-9.24</td> <td>-22.73</td> <td>-22.43</td> <td>-29.35</td> <td>-16.43</td> <td>-22.63</td> </tr> <tr> <td>47.00</td> <td>53.51</td> <td>32.08</td> <td>45.16</td> <td>32.50</td> <td>46.30</td> </tr> <tr> <td>-2.24</td> <td>-2.24</td> <td>-0.51</td> <td>-0.51</td> <td>5.07</td> <td>5.07</td> </tr> <tr> <td>Average</td> <td>Peak</td> <td>Average</td> <td>Peak</td> <td>Average</td> <td>Peak</td> </tr> <tr> <td>305</td> <td>305</td> <td>100</td> <td>100</td> <td>100</td> <td>100</td> </tr> <tr> <td>206</td> <td>206</td> <td>138</td> <td>138</td> <td>211</td> <td>211</td> </tr> </tbody> </table>	1	2	3	4	5	6	4000.00	4000.00	4924.00	4924.00	7386.00	7386.00	44.76	51.27	31.57	44.65	37.57	51.37	54.00	74.00	54.00	74.00	54.00	74.00	-9.24	-22.73	-22.43	-29.35	-16.43	-22.63	47.00	53.51	32.08	45.16	32.50	46.30	-2.24	-2.24	-0.51	-0.51	5.07	5.07	Average	Peak	Average	Peak	Average	Peak	305	305	100	100	100	100	206	206	138	138	211	211	<table border="1"> <thead> <tr> <th>Freq. MHz</th> <th>Emission level dBuV/m</th> <th>Limit dBuV/m</th> <th>Margin dB</th> <th>SA reading dBuV</th> <th>Factor dB/m</th> <th>Remark</th> <th>ANT High cm</th> <th>Turn Table deg</th> </tr> </thead> <tbody> <tr> <td>4000.00</td> <td>44.76</td> <td>54.00</td> <td>-9.24</td> <td>47.00</td> <td>-2.24</td> <td>Average</td> <td>305</td> <td>206</td> </tr> <tr> <td>4000.00</td> <td>51.27</td> <td>74.00</td> <td>-22.73</td> <td>53.51</td> <td>-2.24</td> <td>Peak</td> <td>305</td> <td>206</td> </tr> <tr> <td>4924.00</td> <td>31.57</td> <td>54.00</td> <td>-22.43</td> <td>32.08</td> <td>-0.51</td> <td>Average</td> <td>100</td> <td>138</td> </tr> <tr> <td>4924.00</td> <td>44.65</td> <td>74.00</td> <td>-29.35</td> <td>45.16</td> <td>-0.51</td> <td>Peak</td> <td>100</td> <td>138</td> </tr> <tr> <td>7386.00</td> <td>37.57</td> <td>54.00</td> <td>-16.43</td> <td>32.50</td> <td>5.07</td> <td>Average</td> <td>100</td> <td>211</td> </tr> <tr> <td>7386.00</td> <td>51.37</td> <td>74.00</td> <td>-22.63</td> <td>46.30</td> <td>5.07</td> <td>Peak</td> <td>100</td> <td>211</td> </tr> </tbody> </table>	Freq. MHz	Emission level dBuV/m	Limit dBuV/m	Margin dB	SA reading dBuV	Factor dB/m	Remark	ANT High cm	Turn Table deg	4000.00	44.76	54.00	-9.24	47.00	-2.24	Average	305	206	4000.00	51.27	74.00	-22.73	53.51	-2.24	Peak	305	206	4924.00	31.57	54.00	-22.43	32.08	-0.51	Average	100	138	4924.00	44.65	74.00	-29.35	45.16	-0.51	Peak	100	138	7386.00	37.57	54.00	-16.43	32.50	5.07	Average	100	211	7386.00	51.37	74.00	-22.63	46.30	5.07	Peak	100	211
1	2	3	4	5	6																																																																																																																								
4000.00	4000.00	4924.00	4924.00	7386.00	7386.00																																																																																																																								
44.76	51.27	31.57	44.65	37.57	51.37																																																																																																																								
54.00	74.00	54.00	74.00	54.00	74.00																																																																																																																								
-9.24	-22.73	-22.43	-29.35	-16.43	-22.63																																																																																																																								
47.00	53.51	32.08	45.16	32.50	46.30																																																																																																																								
-2.24	-2.24	-0.51	-0.51	5.07	5.07																																																																																																																								
Average	Peak	Average	Peak	Average	Peak																																																																																																																								
305	305	100	100	100	100																																																																																																																								
206	206	138	138	211	211																																																																																																																								
Freq. MHz	Emission level dBuV/m	Limit dBuV/m	Margin dB	SA reading dBuV	Factor dB/m	Remark	ANT High cm	Turn Table deg																																																																																																																					
4000.00	44.76	54.00	-9.24	47.00	-2.24	Average	305	206																																																																																																																					
4000.00	51.27	74.00	-22.73	53.51	-2.24	Peak	305	206																																																																																																																					
4924.00	31.57	54.00	-22.43	32.08	-0.51	Average	100	138																																																																																																																					
4924.00	44.65	74.00	-29.35	45.16	-0.51	Peak	100	138																																																																																																																					
7386.00	37.57	54.00	-16.43	32.50	5.07	Average	100	211																																																																																																																					
7386.00	51.37	74.00	-22.63	46.30	5.07	Peak	100	211																																																																																																																					
Note 1: Emission Level (dBuV/m) = SA Reading (dBuV) + Factor* (dB/m) *Factor includes antenna factor , cable loss and amplifier gain Note 2: Margin (dB) = Emission level (dBuV/m) – Limit (dBuV/m).																																																																																																																													





Unwanted Emissions (Above 1GHz) for ax HE20-OFDMA

Modulation	ax HE20-OFDMA	Test Freq. (MHz)	2412						
Polarization	Horizontal								
Test By :Paul Lin      Temperature(°C):25      Humidity(%):62									
	Freq. MHz	Emission level dBuV/m	Limit dBuV/m	Margin dB	SA reading dBuV	Factor dB/m	Remark	ANT High cm	Turn Table deg
1	4000.00	50.84	54.00	-3.16	53.08	-2.24	Average	286	132
2	4000.00	55.16	74.00	-18.84	57.40	-2.24	Peak	286	132
3	4824.00	31.80	54.00	-22.20	32.33	-0.53	Average	100	115
4	4824.00	44.76	74.00	-29.24	45.29	-0.53	Peak	100	115
5	12060.00	42.43	54.00	-11.57	36.06	6.37	Average	100	138
6	12060.00	55.73	74.00	-18.27	49.36	6.37	Peak	100	138

Note 1: Emission Level (dBuV/m) = SA Reading (dBuV) + Factor\* (dB/m)  
 \*Factor includes antenna factor , cable loss and amplifier gain  
 Note 2: Margin (dB) = Emission level (dBuV/m) – Limit (dBuV/m).



**Unwanted Radiated Emissions into Restricted Frequency Bands**

**Appendix D.7**

<b>Modulation</b>	ax HE20-OFDMA	<b>Test Freq. (MHz)</b>	2412						
<b>Polarization</b>	Vertical								
Test By : Paul Lin		Temperature(°C): 25		Humidity(%): 62					
	Freq.	Emission level	Limit	Margin	SA reading	Factor	Remark	ANT High	Turn Table
	MHz	dBuV/m	dBuV/m	dB	dBuV	dB/m		cm	deg
1	4000.00	45.11	54.00	-8.89	47.35	-2.24	Average	305	203
2	4000.00	51.48	74.00	-22.52	53.72	-2.24	Peak	305	203
3	4824.00	31.57	54.00	-22.43	32.10	-0.53	Average	100	126
4	4824.00	44.76	74.00	-29.24	45.29	-0.53	Peak	100	126
5	12060.00	42.62	54.00	-11.38	36.25	6.37	Average	100	188
6	12060.00	56.04	74.00	-17.96	49.67	6.37	Peak	100	188

Note 1: Emission Level (dBUV/m) = SA Reading (dBUV) + Factor\* (dB/m)  
 \*Factor includes antenna factor , cable loss and amplifier gain  
 Note 2: Margin (dB) = Emission level (dBUV/m) – Limit (dBUV/m).



**Unwanted Radiated Emissions into Restricted Frequency Bands**

**Appendix D.7**

<b>Modulation</b>	ax HE20-OFDMA	<b>Test Freq. (MHz)</b>	2437						
<b>Polarization</b>	Horizontal								
Test By : Paul Lin		Temperature(°C): 25		Humidity(%): 62					
	Freq.	Emission level	Limit	Margin	SA reading	Factor	Remark	ANT High	Turn Table
	MHz	dBuV/m	dBuV/m	dB	dBuV	dB/m		cm	deg
1	4000.00	50.92	54.00	-3.08	53.16	-2.24	Average	287	130
2	4000.00	55.55	74.00	-18.45	57.79	-2.24	Peak	287	130
3	4874.00	31.58	54.00	-22.42	32.12	-0.54	Average	100	125
4	4874.00	44.85	74.00	-29.15	45.39	-0.54	Peak	100	125
5	7311.00	37.57	54.00	-16.43	32.35	5.22	Average	100	192
6	7311.00	51.48	74.00	-22.52	46.26	5.22	Peak	100	192
<p>Note 1: Emission Level (dBuV/m) = SA Reading (dBuV) + Factor* (dB/m)          *Factor includes antenna factor , cable loss and amplifier gain          Note 2: Margin (dB) = Emission level (dBuV/m) – Limit (dBuV/m).</p>									



**Unwanted Radiated Emissions into Restricted Frequency Bands**

**Appendix D.7**

<b>Modulation</b>	ax HE20-OFDMA	<b>Test Freq. (MHz)</b>	2437						
<b>Polarization</b>	Vertical								
Test By : Paul Lin		Temperature(°C): 25		Humidity(%): 62					
	Freq. MHz	Emission level dBuV/m	Limit dBuV/m	Margin dB	SA reading dBuV	Factor dB/m	Remark	ANT High cm	Turn Table deg
1	4000.00	44.98	54.00	-9.02	47.22	-2.24	Average	304	207
2	4000.00	51.33	74.00	-22.67	53.57	-2.24	Peak	304	207
3	4874.00	31.58	54.00	-22.42	32.12	-0.54	Average	100	85
4	4874.00	44.94	74.00	-29.06	45.48	-0.54	Peak	100	85
5	7311.00	37.74	54.00	-16.26	32.52	5.22	Average	100	118
6	7311.00	51.35	74.00	-22.65	46.13	5.22	Peak	100	118

Note 1: Emission Level (dBuV/m) = SA Reading (dBuV) + Factor\* (dB/m)  
 \*Factor includes antenna factor , cable loss and amplifier gain  
 Note 2: Margin (dB) = Emission level (dBuV/m) – Limit (dBuV/m).



**Unwanted Radiated Emissions into Restricted Frequency Bands**

**Appendix D.7**

<b>Modulation</b>	ax HE20-OFDMA	<b>Test Freq. (MHz)</b>	2462
<b>Polarization</b>	Horizontal		

Test By :Paul Lin      Temperature(°C):25      Humidity(%):62

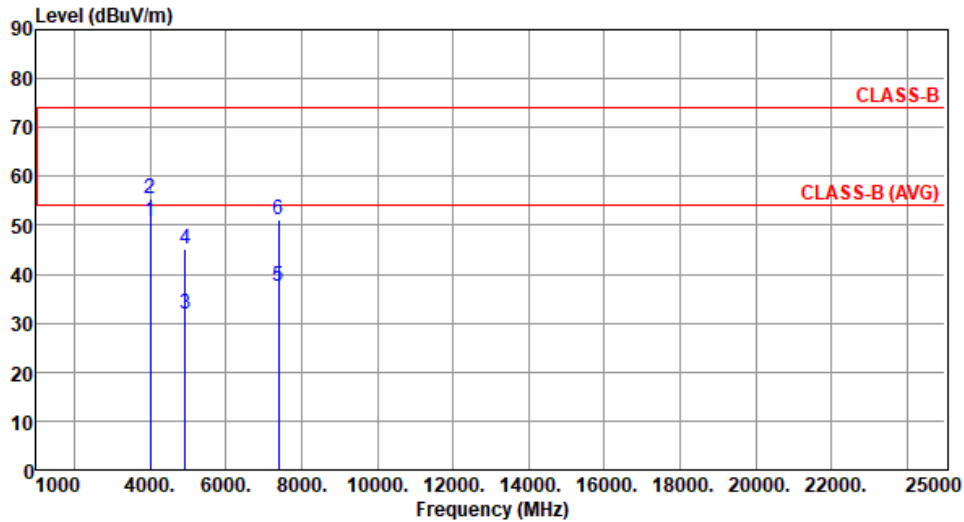

	Freq. MHz	Emission level dBuV/m	Limit dBuV/m	Margin dB	SA reading dBuV	Factor dB/m	Remark	ANT High cm	Turn Table deg
1	4000.00	50.91	54.00	-3.09	53.15	-2.24	Average	288	132
2	4000.00	55.41	74.00	-18.59	57.65	-2.24	Peak	288	132
3	4924.00	31.75	54.00	-22.25	32.26	-0.51	Average	100	109
4	4924.00	45.16	74.00	-28.84	45.67	-0.51	Peak	100	109
5	7386.00	37.59	54.00	-16.41	32.52	5.07	Average	100	172
6	7386.00	51.03	74.00	-22.97	45.96	5.07	Peak	100	172

Note 1: Emission Level (dBuV/m) = SA Reading (dBuV) + Factor\* (dB/m)

\*Factor includes antenna factor , cable loss and amplifier gain

Note 2: Margin (dB) = Emission level (dBuV/m) – Limit (dBuV/m).



**Unwanted Radiated Emissions into Restricted Frequency Bands**

**Appendix D.7**

<b>Modulation</b>	ax HE20-OFDMA	<b>Test Freq. (MHz)</b>	2462						
<b>Polarization</b>	Vertical								
Test By : Paul Lin		Temperature(°C): 25		Humidity(%): 62					
	Freq. MHz	Emission level dBuV/m	Limit dBuV/m	Margin dB	SA reading dBuV	Factor dB/m	Remark	ANT High cm	Turn Table deg
1	4000.00	45.18	54.00	-8.82	47.42	-2.24	Average	304	206
2	4000.00	51.42	74.00	-22.58	53.66	-2.24	Peak	304	206
3	4924.00	31.68	54.00	-22.32	32.19	-0.51	Average	100	144
4	4924.00	45.01	74.00	-28.99	45.52	-0.51	Peak	100	144
5	7386.00	37.79	54.00	-16.21	32.72	5.07	Average	100	209
6	7386.00	51.64	74.00	-22.36	46.57	5.07	Peak	100	209

Note 1: Emission Level (dBuV/m) = SA Reading (dBuV) + Factor\* (dB/m)  
 \*Factor includes antenna factor , cable loss and amplifier gain  
 Note 2: Margin (dB) = Emission level (dBuV/m) – Limit (dBuV/m).



ST M.2, PCIe Module

Emissions (Below 1GHz)

Modulation	11b	Test Freq. (MHz)	2437
Polarization	Horizontal		

Test By :Paul Lin      Temperature(°C):24      Humidity(%):66

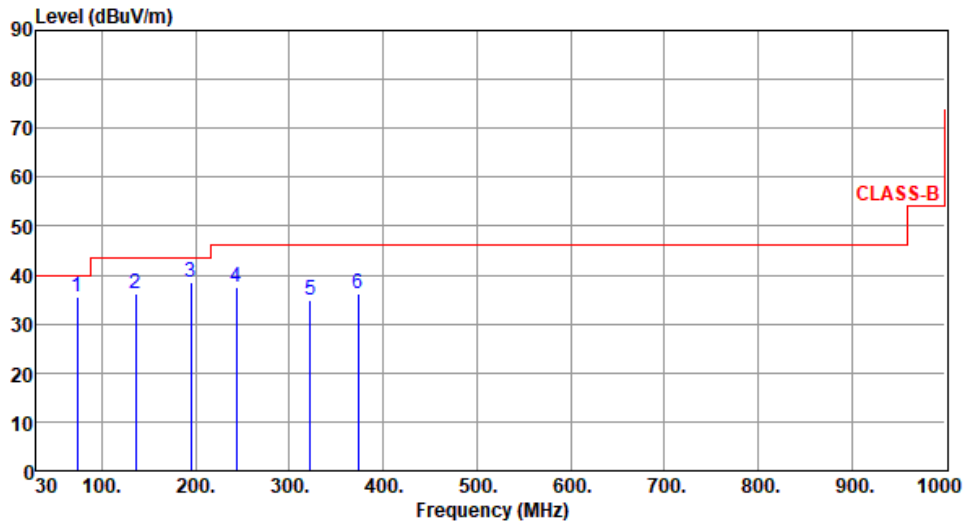

	Freq. MHz	Emission level dBuV/m	Limit dBuV/m	Margin dB	SA reading dBuV	Factor dB/m	Remark	ANT High cm	Turn Table deg
1	73.48	35.66	40.00	-4.34	47.71	-12.05	Peak	---	---
2	135.73	36.31	43.50	-7.19	46.05	-9.74	Peak	---	---
3	194.90	38.59	43.50	-4.91	50.27	-11.68	Peak	---	---
4	243.40	37.53	46.00	-8.47	47.81	-10.28	Peak	---	---
5	321.97	34.78	46.00	-11.22	42.30	-7.52	Peak	---	---
6	373.38	36.20	46.00	-9.80	42.51	-6.31	Peak	---	---

Note 1: Emission Level (dBuV/m) = SA Reading (dBuV) + Factor\* (dB/m)

\*Factor includes antenna factor , cable loss and amplifier gain

Note 2: Margin (dB) = Emission level (dBuV/m) – Limit (dBuV/m).

Note 3: All spurious emissions below 30MHz are more than 20 dB below the limit.



**Unwanted Radiated Emissions into Restricted Frequency Bands**

**Appendix D.7**

<b>Modulation</b>	11b	<b>Test Freq. (MHz)</b>	2437
<b>Polarization</b>	Vertical		

Test By : Paul Lin      Temperature(°C): 24      Humidity(%): 66

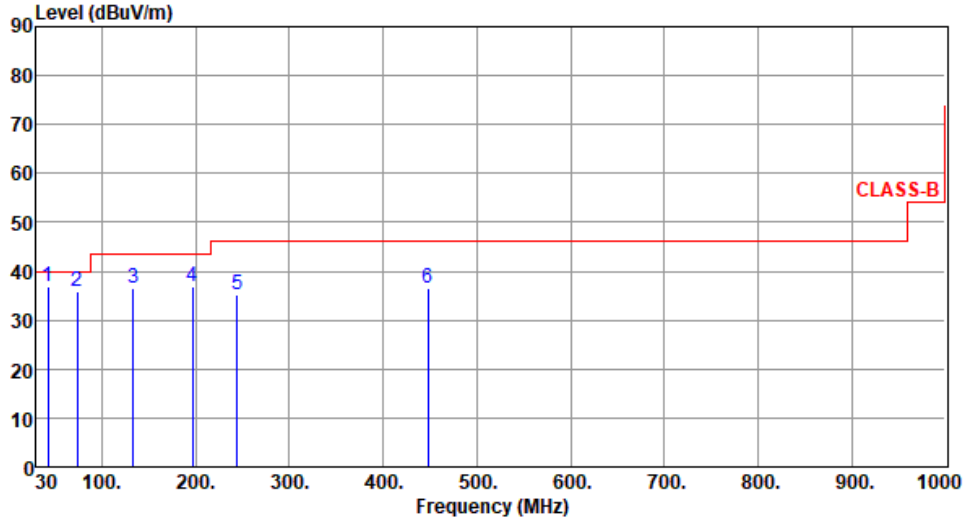

	Freq. MHz	Emission level dBuV/m	Limit dBuV/m	Margin dB	SA reading dBuV	Factor dB/m	Remark	ANT High cm	Turn Table deg
1	42.61	36.76	40.00	-3.24	45.10	-8.34	QP	100	135
2	73.72	35.97	40.00	-4.03	48.10	-12.13	Peak	---	---
3	133.25	36.44	43.50	-7.06	46.49	-10.05	Peak	---	---
4	196.91	36.96	43.50	-6.54	48.82	-11.86	Peak	---	---
5	244.58	35.11	46.00	-10.89	45.32	-10.21	Peak	---	---
6	448.23	36.57	46.00	-9.43	40.83	-4.26	Peak	---	---

Note 1: Emission Level (dBuV/m) = SA Reading (dBuV) + Factor\* (dB/m)

\*Factor includes antenna factor , cable loss and amplifier gain

Note 2: Margin (dB) = Emission level (dBuV/m) – Limit (dBuV/m).

Note 3: All spurious emissions below 30MHz are more than 20 dB below the limit.





**Unwanted Emission (Above 1GHz)**

<b>Modulation</b>	11b	<b>Test Freq. (MHz)</b>	2437						
<b>Polarization</b>	Horizontal								
Test By : Sean Yu      Temperature(°C): 25      Humidity(%): 62									
	Freq. MHz	Emission level dBuV/m	Limit dBuV/m	Margin dB	SA reading dBuV	Factor dB/m	Remark	ANT High cm	Turn Table deg
1	4000.00	50.87	54.00	-3.13	53.11	-2.24	Average	285	136
2	4000.00	55.27	74.00	-18.73	57.51	-2.24	Peak	285	136
3	4874.00	31.00	54.00	-23.00	31.54	-0.54	Average	100	211
4	4874.00	44.02	74.00	-29.98	44.56	-0.54	Peak	100	211
5	7311.00	37.80	54.00	-16.20	32.58	5.22	Average	100	184
6	7311.00	50.16	74.00	-23.84	44.94	5.22	Peak	100	184

Note 1: Emission Level (dBuV/m) = SA Reading (dBuV) + Factor\* (dB/m)  
 \*Factor includes antenna factor , cable loss and amplifier gain  
 Note 2: Margin (dB) = Emission level (dBuV/m) – Limit (dBuV/m).



**Unwanted Radiated Emissions into Restricted Frequency Bands**

**Appendix D.7**

<b>Modulation</b>	11b	<b>Test Freq. (MHz)</b>	2437																																																																																																																										
<b>Polarization</b>	Vertical																																																																																																																												
Test By : Sean Yu      Temperature(°C): 25      Humidity(%): 62																																																																																																																													
	<table border="1"> <thead> <tr> <th>1</th> <th>2</th> <th>3</th> <th>4</th> <th>5</th> <th>6</th> </tr> </thead> <tbody> <tr> <td>4000.00</td> <td>4000.00</td> <td>4874.00</td> <td>4874.00</td> <td>7311.00</td> <td>7311.00</td> </tr> <tr> <td>44.62</td> <td>51.34</td> <td>31.10</td> <td>44.25</td> <td>38.05</td> <td>50.86</td> </tr> <tr> <td>54.00</td> <td>74.00</td> <td>54.00</td> <td>74.00</td> <td>54.00</td> <td>74.00</td> </tr> <tr> <td>-9.38</td> <td>-22.66</td> <td>-22.90</td> <td>-29.75</td> <td>-15.95</td> <td>-23.14</td> </tr> <tr> <td>46.86</td> <td>53.58</td> <td>31.64</td> <td>44.79</td> <td>32.83</td> <td>45.64</td> </tr> <tr> <td>-2.24</td> <td>-2.24</td> <td>-0.54</td> <td>-0.54</td> <td>5.22</td> <td>5.22</td> </tr> <tr> <td>Average</td> <td>Peak</td> <td>Average</td> <td>Peak</td> <td>Average</td> <td>Peak</td> </tr> <tr> <td>302</td> <td>302</td> <td>100</td> <td>100</td> <td>100</td> <td>100</td> </tr> <tr> <td>208</td> <td>208</td> <td>258</td> <td>258</td> <td>102</td> <td>102</td> </tr> </tbody> </table>	1	2	3	4	5	6	4000.00	4000.00	4874.00	4874.00	7311.00	7311.00	44.62	51.34	31.10	44.25	38.05	50.86	54.00	74.00	54.00	74.00	54.00	74.00	-9.38	-22.66	-22.90	-29.75	-15.95	-23.14	46.86	53.58	31.64	44.79	32.83	45.64	-2.24	-2.24	-0.54	-0.54	5.22	5.22	Average	Peak	Average	Peak	Average	Peak	302	302	100	100	100	100	208	208	258	258	102	102	<table border="1"> <thead> <tr> <th>Freq. MHz</th> <th>Emission level dBuV/m</th> <th>Limit dBuV/m</th> <th>Margin dB</th> <th>SA reading dBuV</th> <th>Factor dB/m</th> <th>Remark</th> <th>ANT High cm</th> <th>Turn Table deg</th> </tr> </thead> <tbody> <tr> <td>4000.00</td> <td>44.62</td> <td>54.00</td> <td>-9.38</td> <td>46.86</td> <td>-2.24</td> <td>Average</td> <td>302</td> <td>208</td> </tr> <tr> <td>4000.00</td> <td>51.34</td> <td>74.00</td> <td>-22.66</td> <td>53.58</td> <td>-2.24</td> <td>Peak</td> <td>302</td> <td>208</td> </tr> <tr> <td>4874.00</td> <td>31.10</td> <td>54.00</td> <td>-22.90</td> <td>31.64</td> <td>-0.54</td> <td>Average</td> <td>100</td> <td>258</td> </tr> <tr> <td>4874.00</td> <td>44.25</td> <td>74.00</td> <td>-29.75</td> <td>44.79</td> <td>-0.54</td> <td>Peak</td> <td>100</td> <td>258</td> </tr> <tr> <td>7311.00</td> <td>38.05</td> <td>54.00</td> <td>-15.95</td> <td>32.83</td> <td>5.22</td> <td>Average</td> <td>100</td> <td>102</td> </tr> <tr> <td>7311.00</td> <td>50.86</td> <td>74.00</td> <td>-23.14</td> <td>45.64</td> <td>5.22</td> <td>Peak</td> <td>100</td> <td>102</td> </tr> </tbody> </table>	Freq. MHz	Emission level dBuV/m	Limit dBuV/m	Margin dB	SA reading dBuV	Factor dB/m	Remark	ANT High cm	Turn Table deg	4000.00	44.62	54.00	-9.38	46.86	-2.24	Average	302	208	4000.00	51.34	74.00	-22.66	53.58	-2.24	Peak	302	208	4874.00	31.10	54.00	-22.90	31.64	-0.54	Average	100	258	4874.00	44.25	74.00	-29.75	44.79	-0.54	Peak	100	258	7311.00	38.05	54.00	-15.95	32.83	5.22	Average	100	102	7311.00	50.86	74.00	-23.14	45.64	5.22	Peak	100	102
1	2	3	4	5	6																																																																																																																								
4000.00	4000.00	4874.00	4874.00	7311.00	7311.00																																																																																																																								
44.62	51.34	31.10	44.25	38.05	50.86																																																																																																																								
54.00	74.00	54.00	74.00	54.00	74.00																																																																																																																								
-9.38	-22.66	-22.90	-29.75	-15.95	-23.14																																																																																																																								
46.86	53.58	31.64	44.79	32.83	45.64																																																																																																																								
-2.24	-2.24	-0.54	-0.54	5.22	5.22																																																																																																																								
Average	Peak	Average	Peak	Average	Peak																																																																																																																								
302	302	100	100	100	100																																																																																																																								
208	208	258	258	102	102																																																																																																																								
Freq. MHz	Emission level dBuV/m	Limit dBuV/m	Margin dB	SA reading dBuV	Factor dB/m	Remark	ANT High cm	Turn Table deg																																																																																																																					
4000.00	44.62	54.00	-9.38	46.86	-2.24	Average	302	208																																																																																																																					
4000.00	51.34	74.00	-22.66	53.58	-2.24	Peak	302	208																																																																																																																					
4874.00	31.10	54.00	-22.90	31.64	-0.54	Average	100	258																																																																																																																					
4874.00	44.25	74.00	-29.75	44.79	-0.54	Peak	100	258																																																																																																																					
7311.00	38.05	54.00	-15.95	32.83	5.22	Average	100	102																																																																																																																					
7311.00	50.86	74.00	-23.14	45.64	5.22	Peak	100	102																																																																																																																					
Note 1: Emission Level (dBuV/m) = SA Reading (dBuV) + Factor* (dB/m) *Factor includes antenna factor , cable loss and amplifier gain Note 2: Margin (dB) = Emission level (dBuV/m) – Limit (dBuV/m).																																																																																																																													



ST M.2, SDIO Module  
Emissions (Below 1GHz)

Modulation	11b	Test Freq. (MHz)	2437
Polarization	Horizontal		

Test By :Paul Lin      Temperature(°C):24      Humidity(%):66

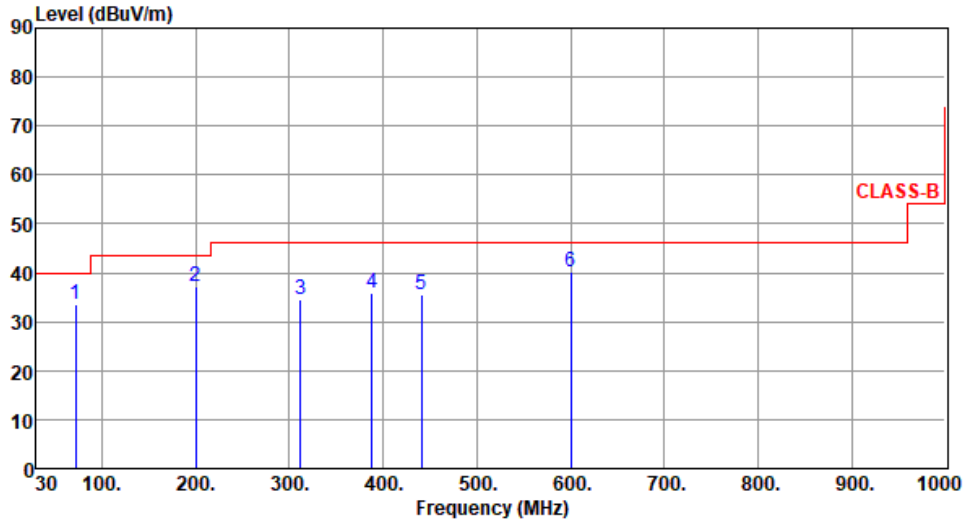

	Freq. MHz	Emission level dBuV/m	Limit dBuV/m	Margin dB	SA reading dBuV	Factor dB/m	Remark	ANT High cm	Turn Table deg
1	72.33	33.45	40.00	-6.55	45.10	-11.65	Peak	---	---
2	199.75	37.23	43.50	-6.27	49.07	-11.84	Peak	---	---
3	312.27	34.56	46.00	-11.44	42.33	-7.77	Peak	---	---
4	387.93	36.01	46.00	-9.99	41.84	-5.83	Peak	---	---
5	441.28	35.41	46.00	-10.59	39.82	-4.41	Peak	---	---
6	600.36	40.32	46.00	-5.68	41.24	-0.92	Peak	---	---

Note 1: Emission Level (dBuV/m) = SA Reading (dBuV) + Factor\* (dB/m)

\*Factor includes antenna factor , cable loss and amplifier gain

Note 2: Margin (dB) = Emission level (dBuV/m) – Limit (dBuV/m).

Note 3: All spurious emissions below 30MHz are more than 20 dB below the limit.



**Unwanted Radiated Emissions into Restricted Frequency Bands**

**Appendix D.7**

<b>Modulation</b>	11b	<b>Test Freq. (MHz)</b>	2437
<b>Polarization</b>	Vertical		

Test By :Paul Lin      Temperature(°C):24      Humidity(%):66

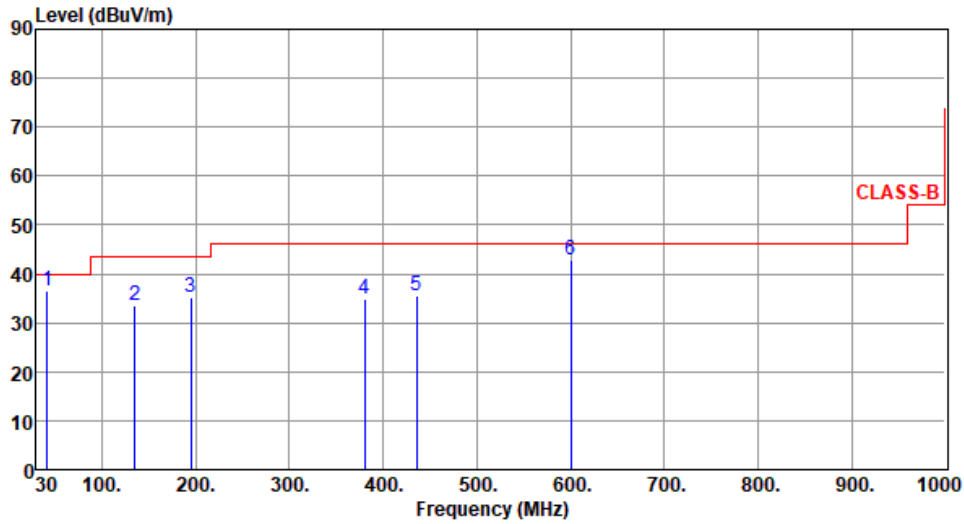

	Freq. MHz	Emission level dBuV/m	Limit dBuV/m	Margin dB	SA reading dBuV	Factor dB/m	Remark	ANT High cm	Turn Table deg
1	41.78	36.52	40.00	-3.48	45.15	-8.63	QP	100	181
2	134.76	33.42	43.50	-10.08	43.31	-9.89	Peak	---	---
3	194.90	35.22	43.50	-8.28	46.90	-11.68	Peak	---	---
4	380.17	34.80	46.00	-11.20	40.82	-6.02	Peak	---	---
5	435.46	35.51	46.00	-10.49	40.06	-4.55	Peak	---	---
6	600.36	42.78	46.00	-3.22	43.70	-0.92	Peak	---	---

Note 1: Emission Level (dBuV/m) = SA Reading (dBuV) + Factor\* (dB/m)

\*Factor includes antenna factor , cable loss and amplifier gain

Note 2: Margin (dB) = Emission level (dBuV/m) – Limit (dBuV/m).

Note 3: All spurious emissions below 30MHz are more than 20 dB below the limit.

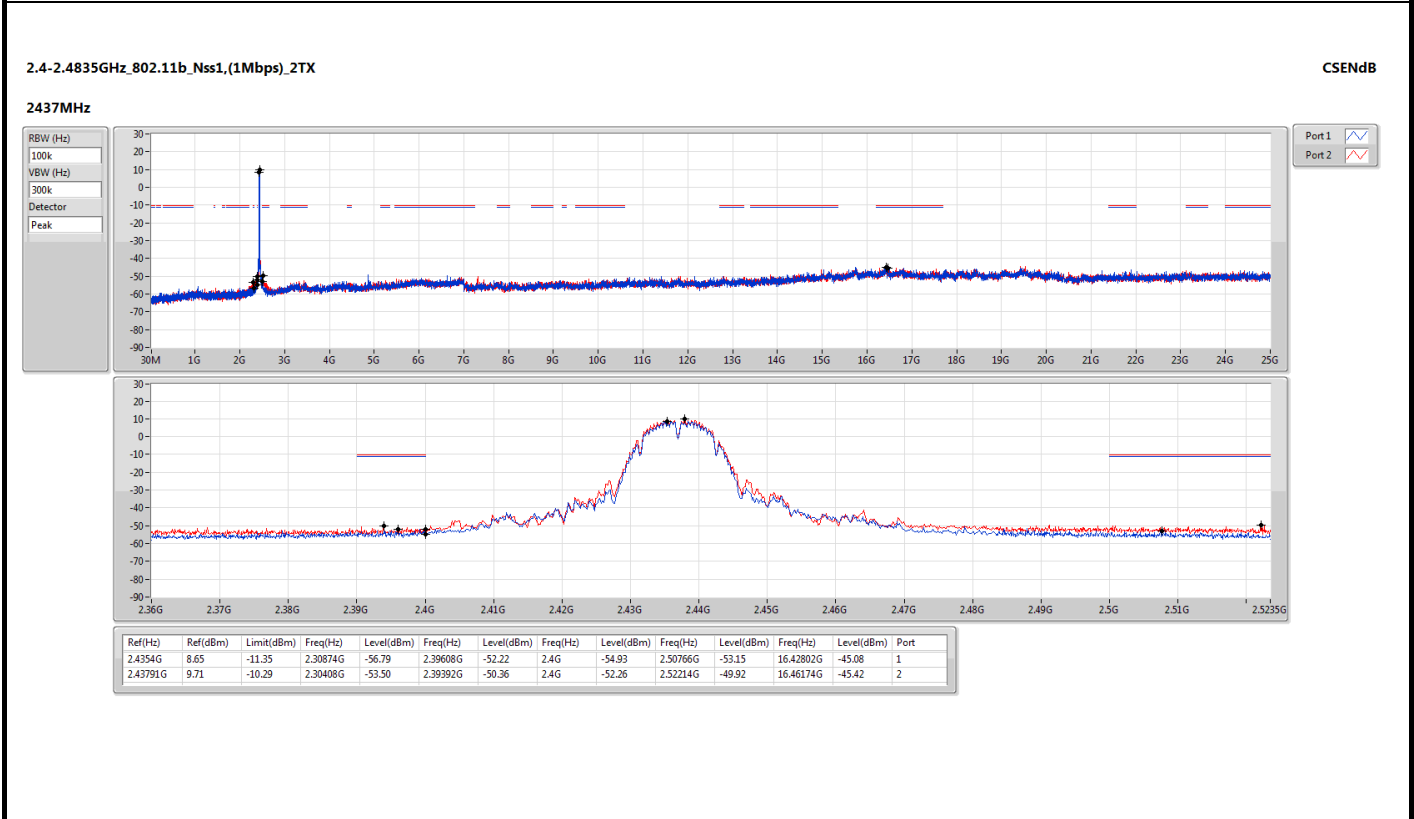
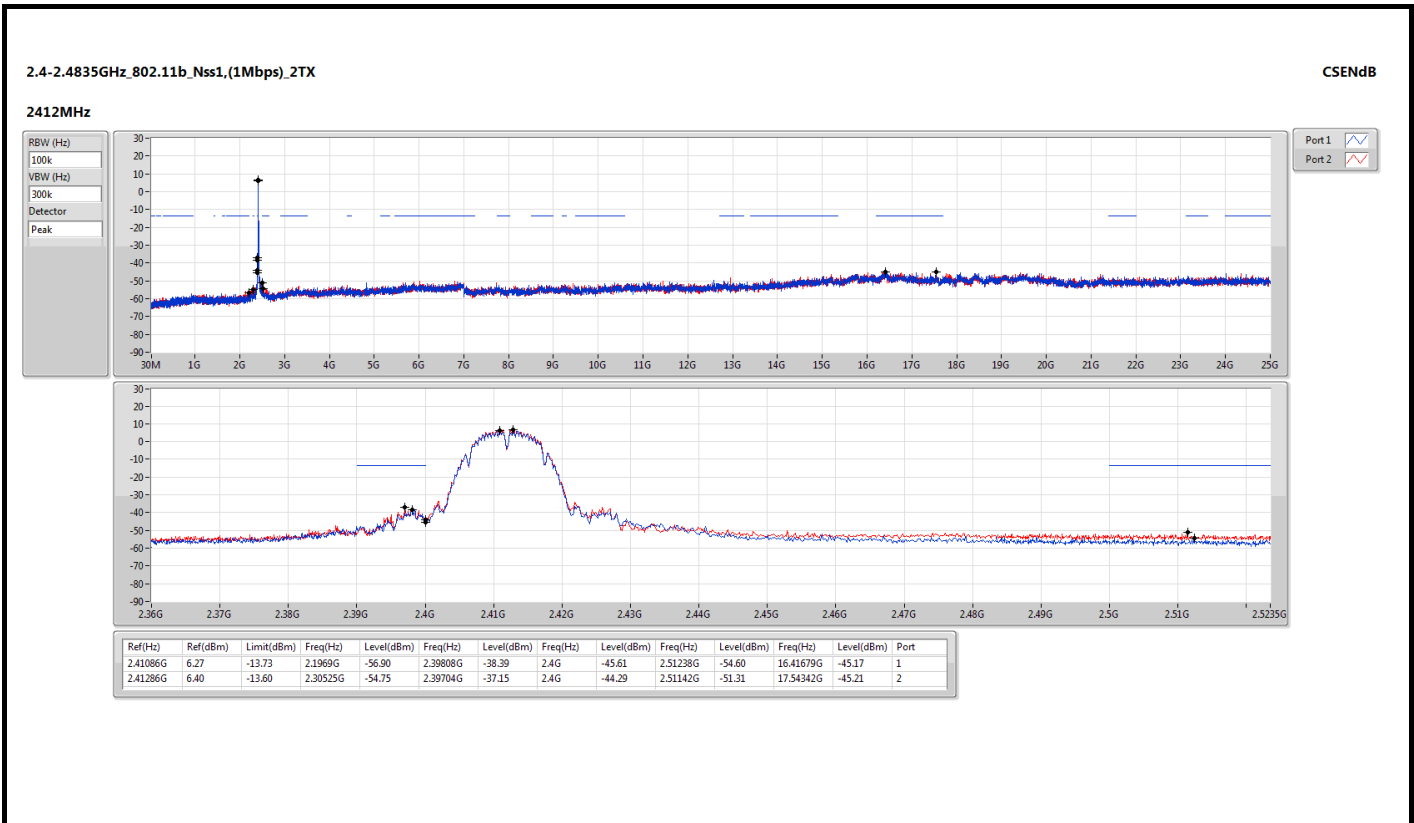

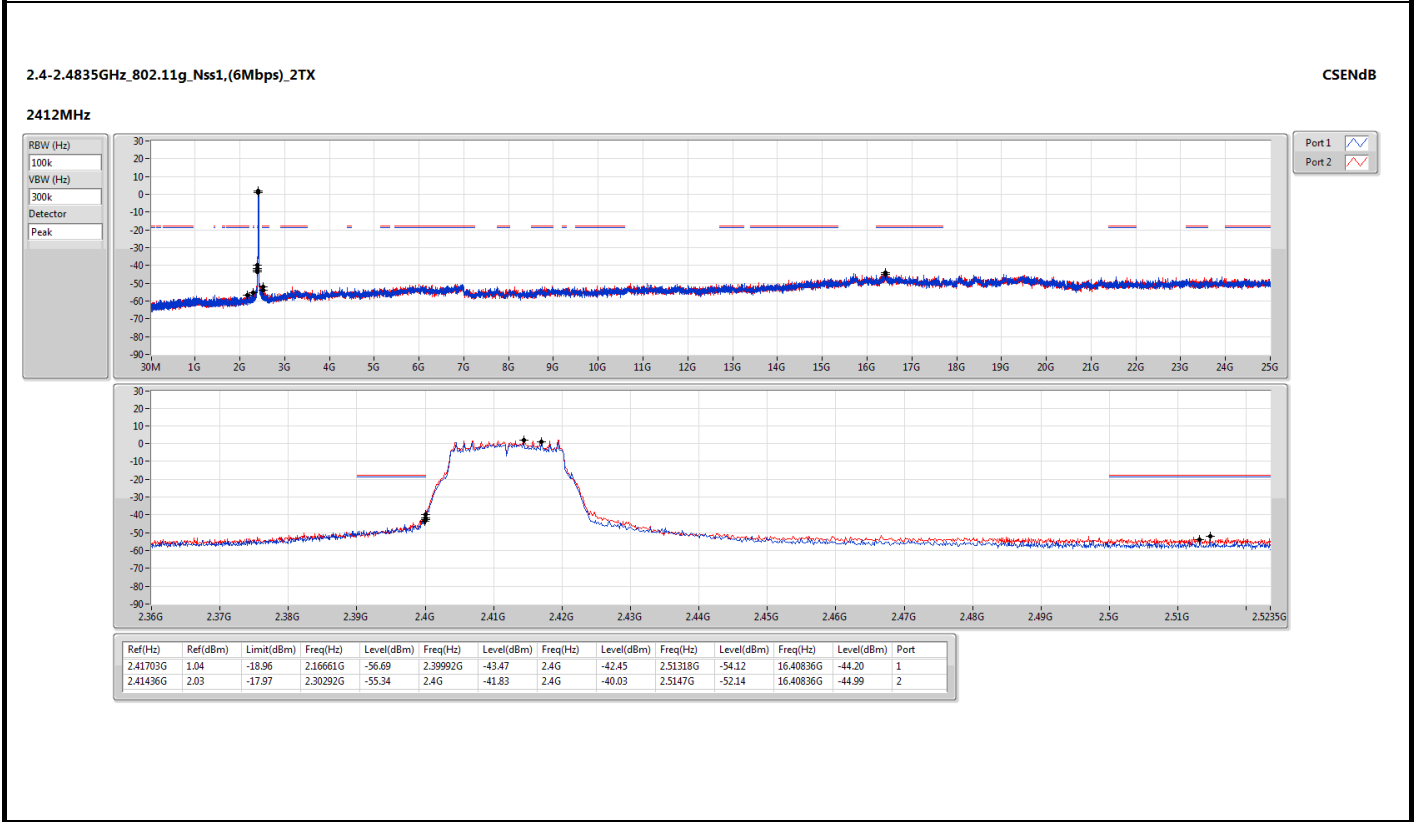
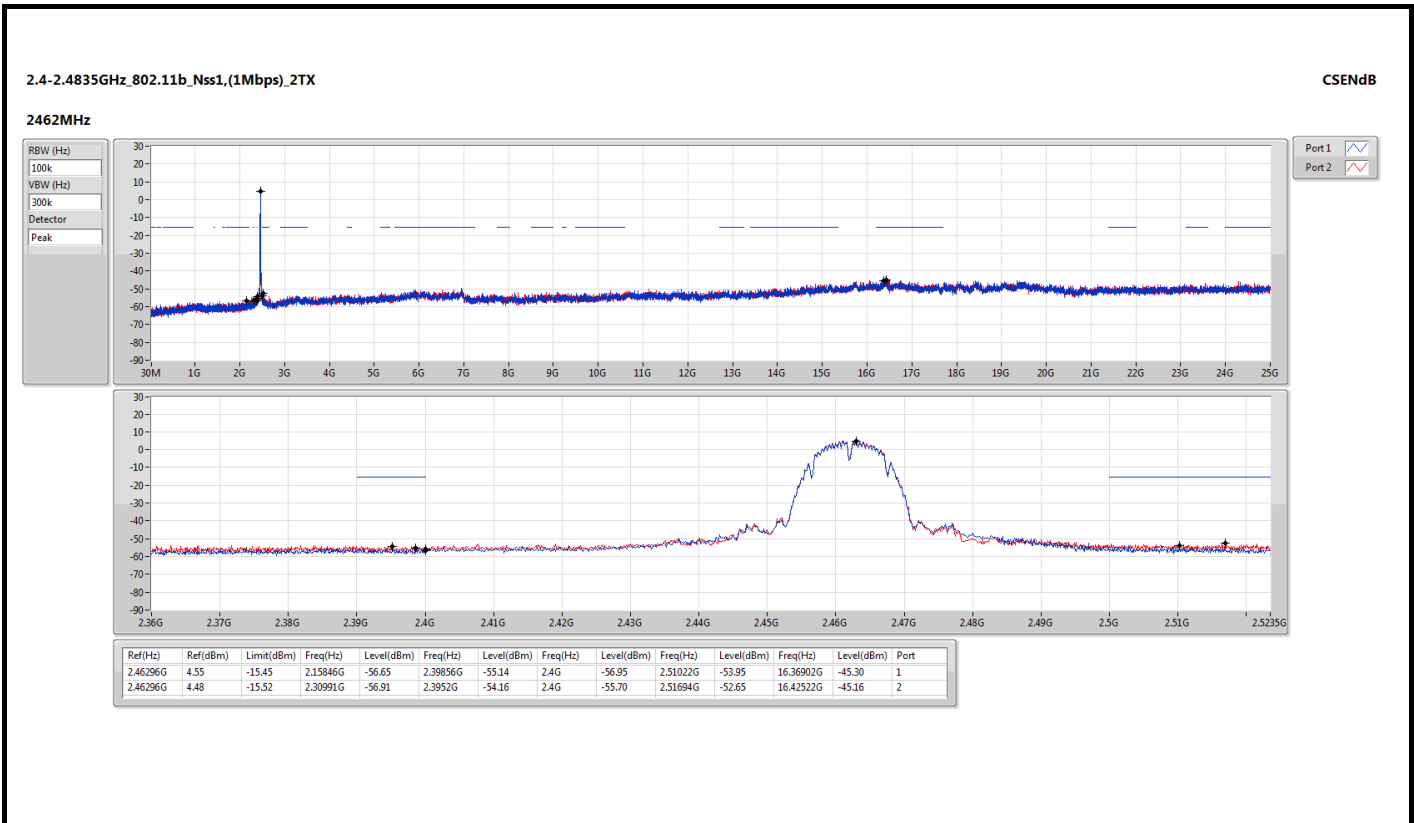

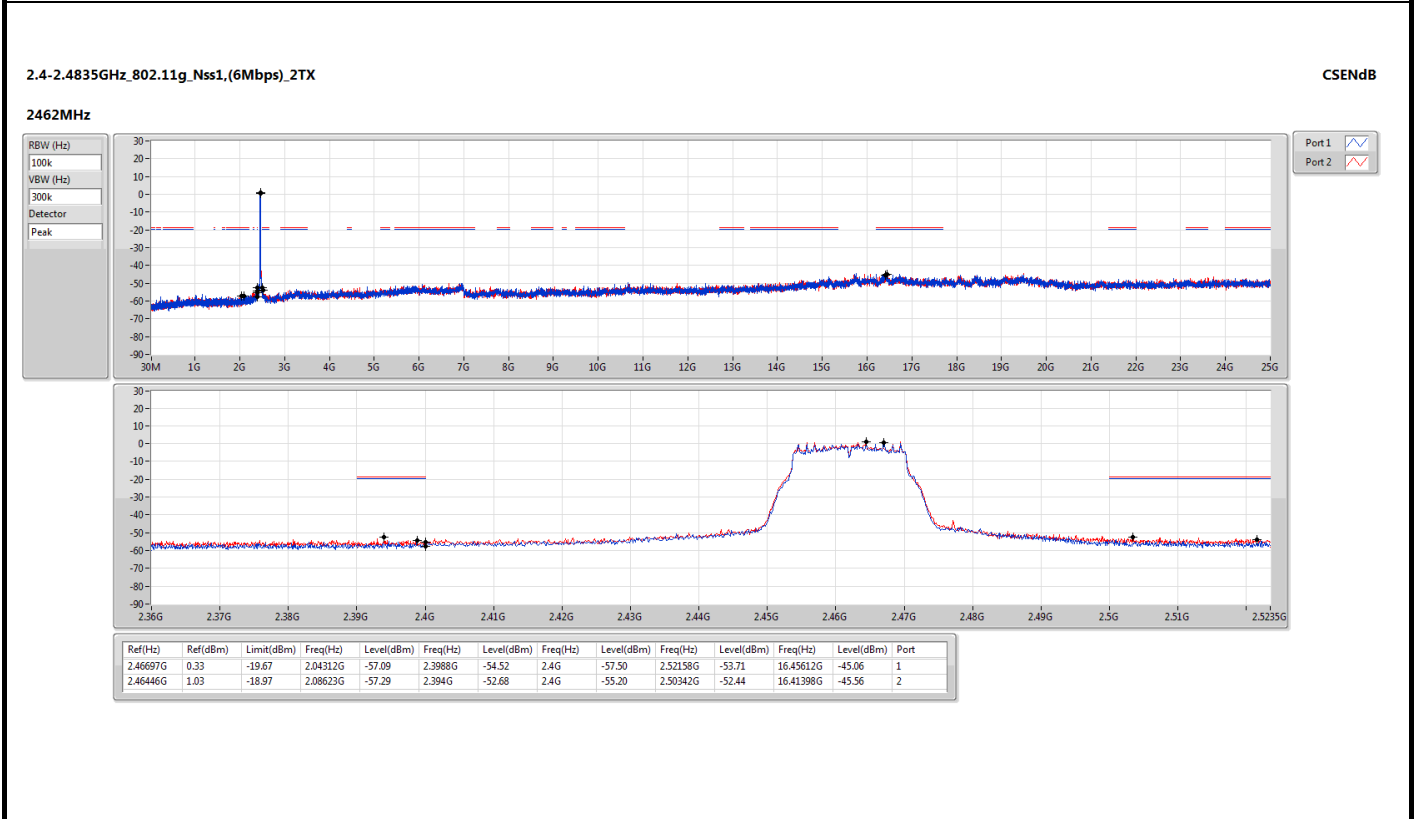
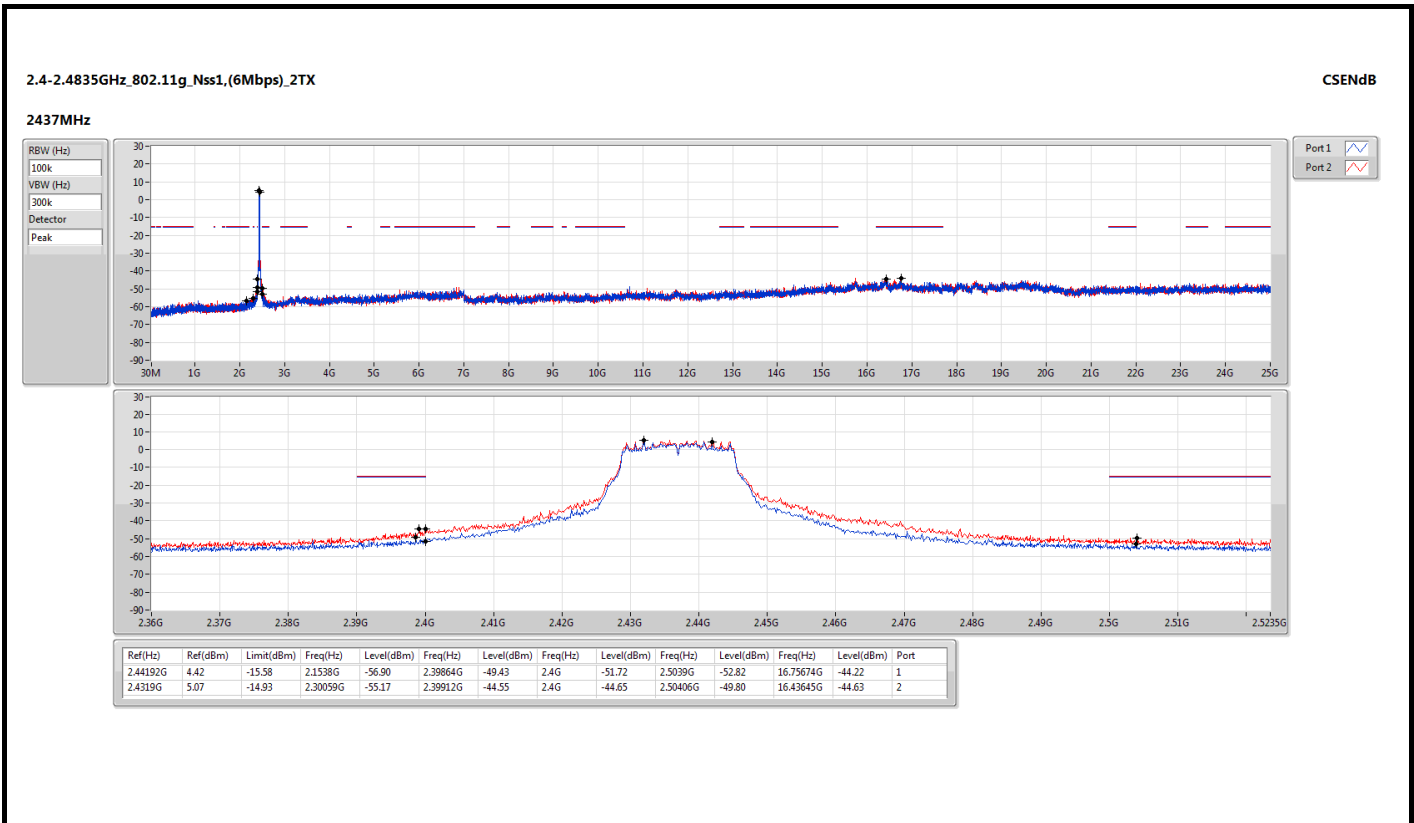

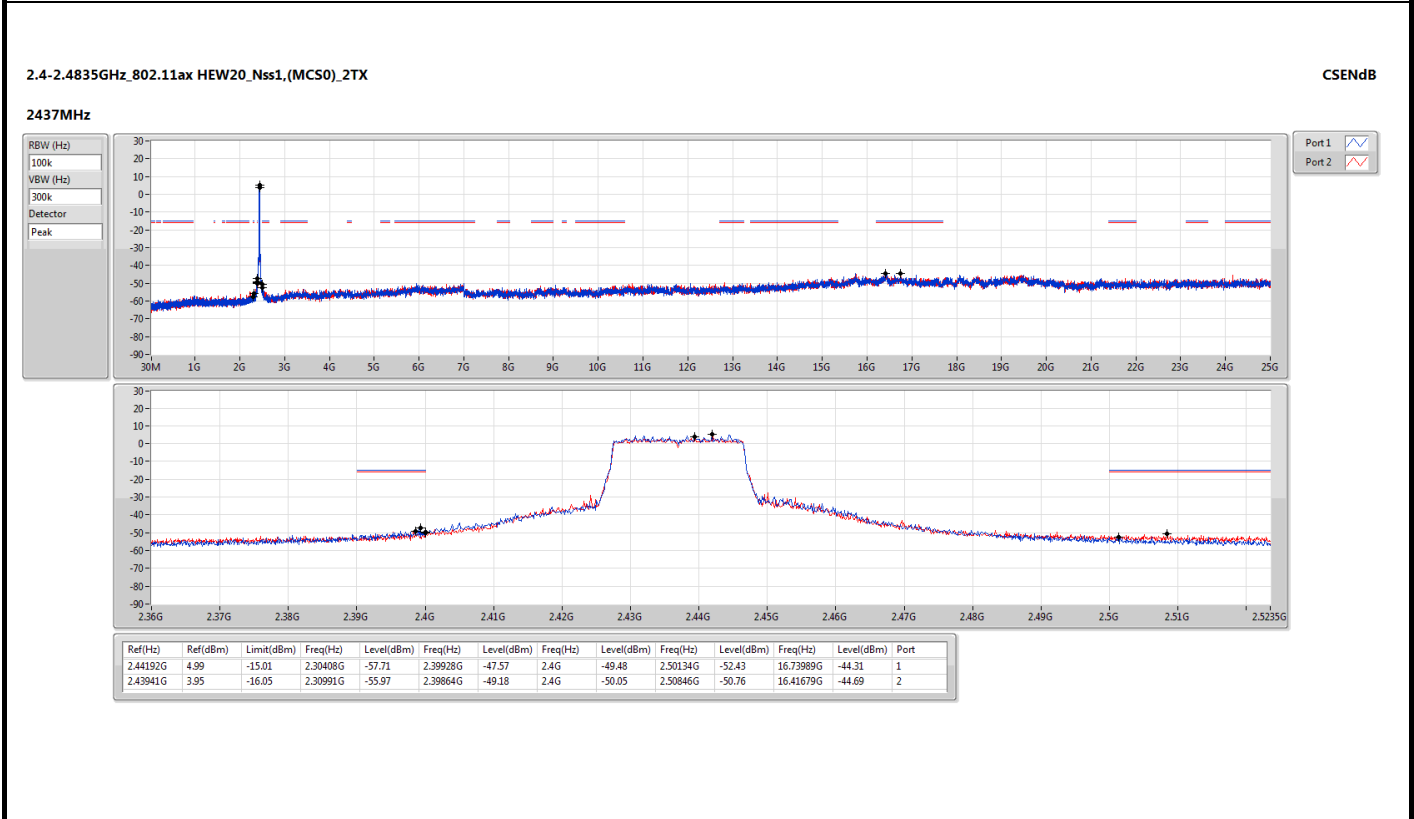
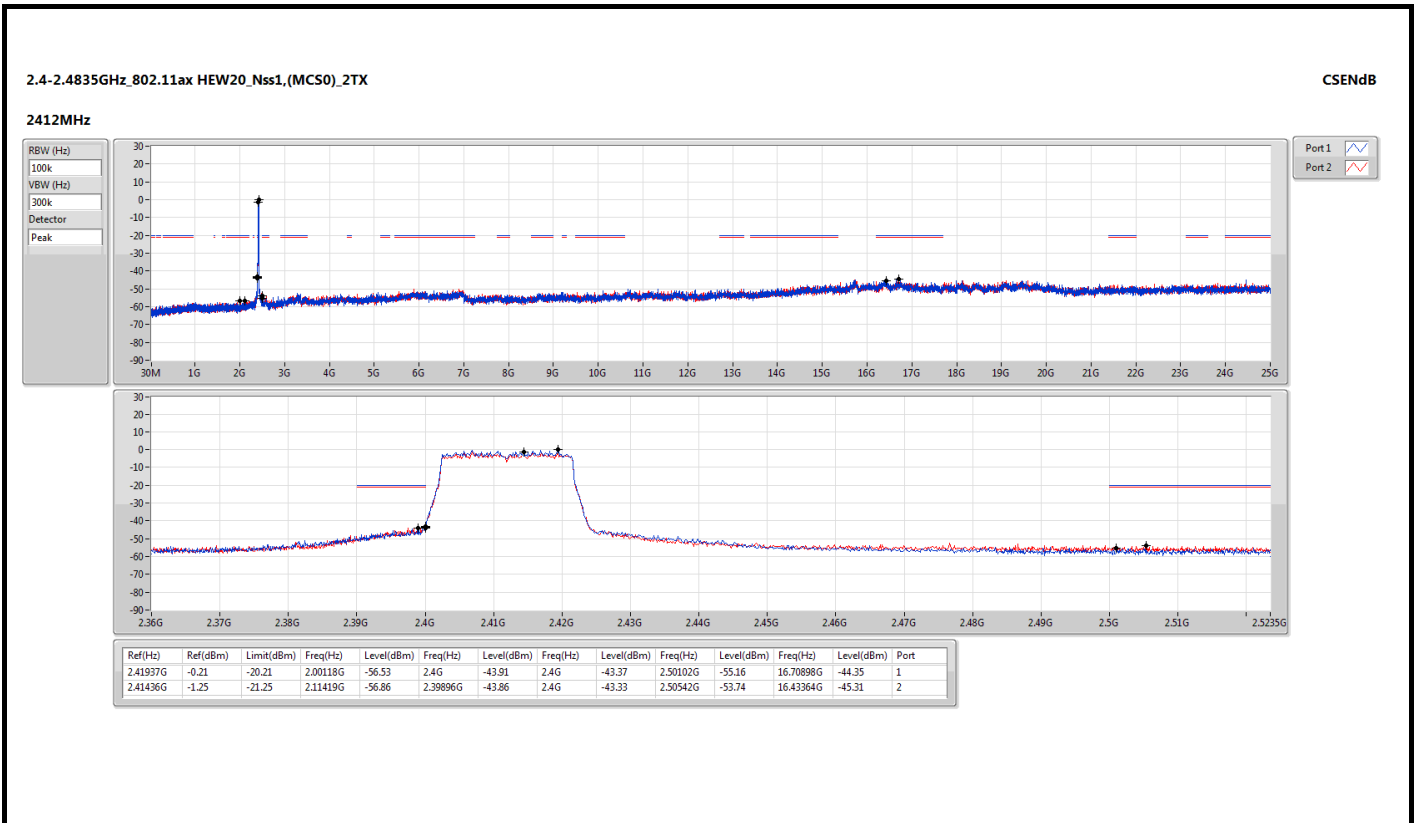



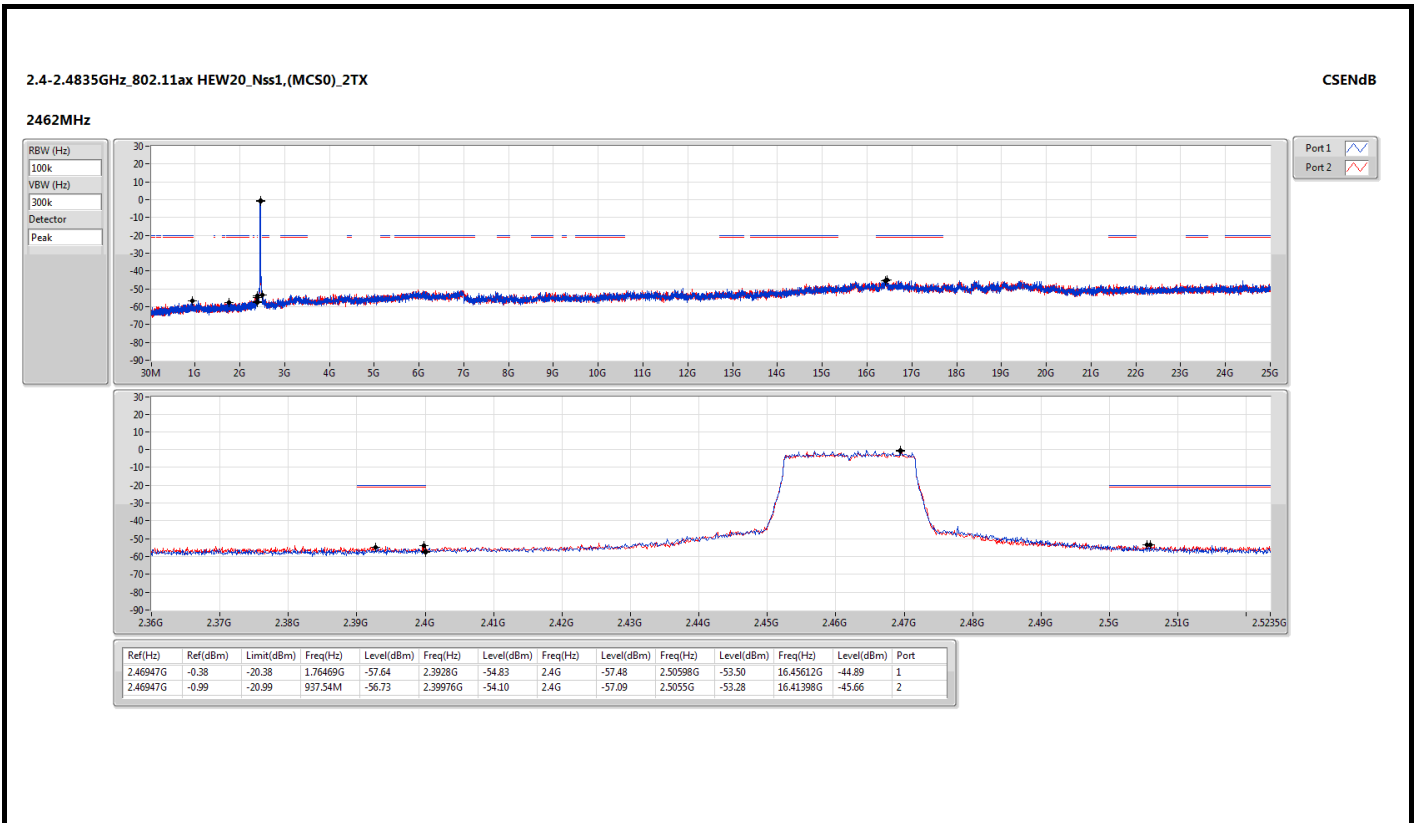



SC Module with PCB Dipole antenna

Modulation	11b	Test Freq. (MHz)	2437
Power Phase	Line		

Test by : Joe Liao      Temperature: 22°C      Humidity: 68%

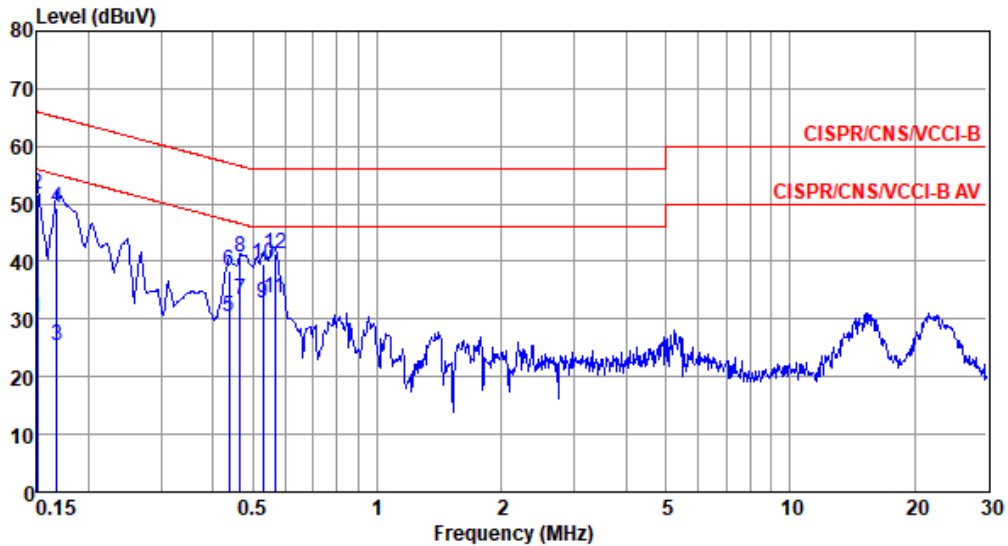

	Freq MHz	Level dBuV	Limit Line dBuV	Over Limit dB	Read Level dBuV	Factor dB	Cable loss dB	Aux dB	Remark
1	0.150	30.21	56.00	-25.79	20.34	9.63	0.06	0.18	Average
2	0.150	51.72	66.00	-14.28	41.85	9.63	0.06	0.18	QP
3	0.168	25.37	55.08	-29.71	15.50	9.63	0.06	0.18	Average
4	0.168	49.20	65.08	-15.88	39.33	9.63	0.06	0.18	QP
5	0.437	30.34	47.11	-16.77	20.36	9.62	0.06	0.30	Average
6	0.437	38.34	57.11	-18.77	28.36	9.62	0.06	0.30	QP
7	0.466	33.48	46.58	-13.10	23.48	9.62	0.07	0.31	Average
8	0.466	40.67	56.58	-15.91	30.67	9.62	0.07	0.31	QP
9	0.529	32.81	46.00	-13.19	22.80	9.62	0.08	0.31	Average
10	0.529	39.54	56.00	-16.46	29.53	9.62	0.08	0.31	QP
11*	0.564	33.77	46.00	-12.23	23.76	9.62	0.08	0.31	Average
12	0.564	41.34	56.00	-14.66	31.33	9.62	0.08	0.31	QP

Note 1: Level (dBuV) = Read Level (dBuV) + LISN Factor (dB) + Cable Loss (dB) + Aux (dB).

Note 2: Over Limit (dB) = Level (dBuV) – Limit Line (dBuV).



Modulation	11b	Test Freq. (MHz)	2437
Power Phase	Neutral		

Test by : Joe Liao      Temperature: 22°C      Humidity: 68%

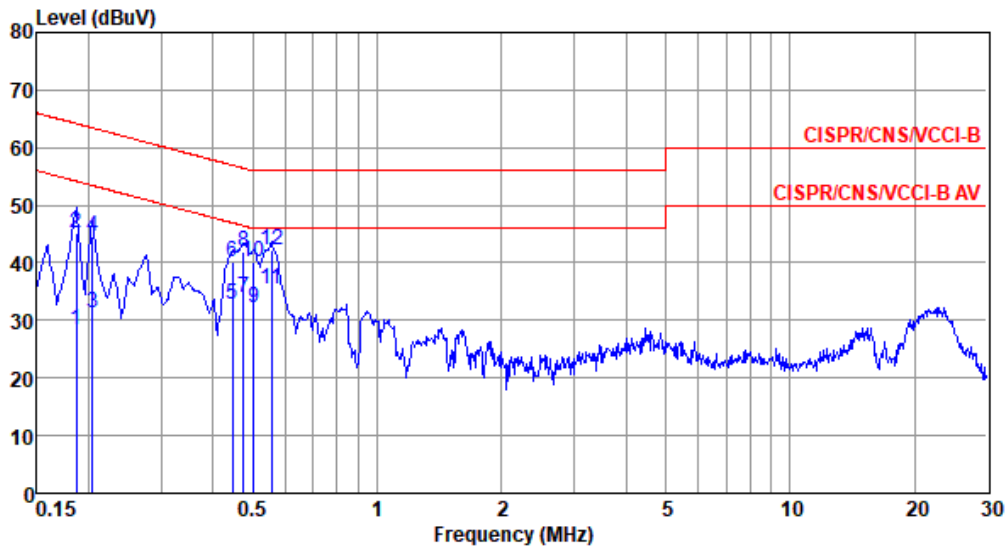

	Freq MHz	Level dBuV	Limit Line dBuV	Over Limit dB	Read Level dBuV	Factor dB	Cable loss dB	Aux dB	Remark
1	0.186	28.25	54.20	-25.95	18.37	9.63	0.06	0.19	Average
2	0.186	45.14	64.20	-19.06	35.26	9.63	0.06	0.19	QP
3	0.204	31.15	53.45	-22.30	21.27	9.63	0.06	0.19	Average
4	0.204	44.52	63.45	-18.93	34.64	9.63	0.06	0.19	QP
5	0.447	32.69	46.93	-14.24	22.70	9.62	0.07	0.30	Average
6	0.447	40.20	56.93	-16.73	30.21	9.62	0.07	0.30	QP
7	0.474	34.08	46.45	-12.37	24.08	9.62	0.07	0.31	Average
8	0.474	41.87	56.45	-14.58	31.87	9.62	0.07	0.31	QP
9	0.502	32.04	46.00	-13.96	22.04	9.62	0.07	0.31	Average
10	0.502	40.07	56.00	-15.93	30.07	9.62	0.07	0.31	QP
11*	0.555	35.41	46.00	-10.59	25.40	9.62	0.08	0.31	Average
12	0.555	42.29	56.00	-13.71	32.28	9.62	0.08	0.31	QP

Note 1: Level (dBuV) = Read Level (dBuV) + LISN Factor (dB) + Cable Loss (dB) + Aux (dB).  
 2: Over Limit (dB) = Level (dBuV) – Limit Line (dBuV).



ST M.2, SDIO Module with PCB Dipole antenna

Modulation	11b	Test Freq. (MHz)	2437
Power Phase	Line		

Test by : Joe Liao      Temperature: 22°C      Humidity: 68%

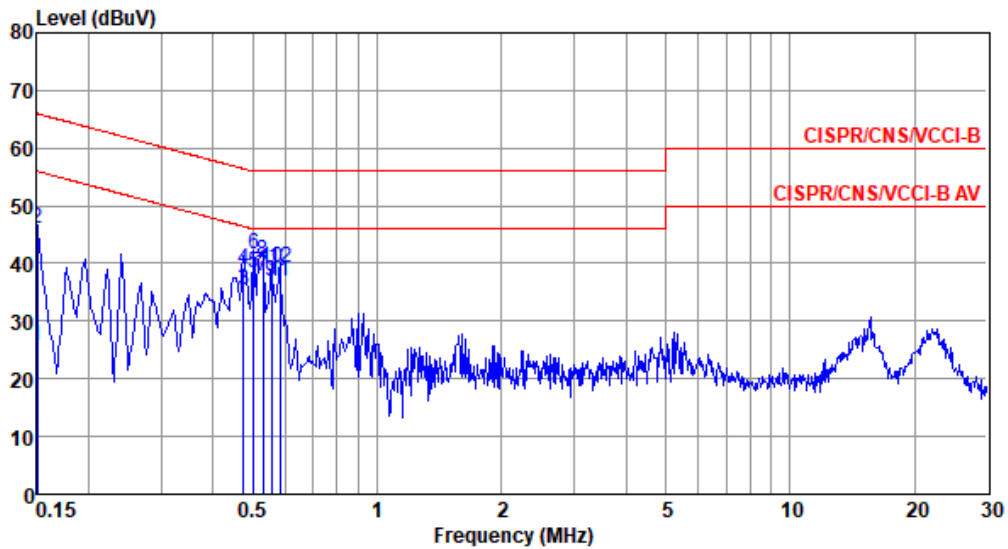

	Freq MHz	Level dBuV	Limit Line dBuV	Over Limit dB	Read Level dBuV	Factor dB	Cable loss dB	Aux dB	Remark
1	0.150	25.65	56.00	-30.35	15.78	9.63	0.06	0.18	Average
2	0.150	46.15	66.00	-19.85	36.28	9.63	0.06	0.18	QP
3	0.474	35.42	46.45	-11.03	25.42	9.62	0.07	0.31	Average
4	0.474	39.10	56.45	-17.35	29.10	9.62	0.07	0.31	QP
5*	0.502	38.49	46.00	-7.51	28.49	9.62	0.07	0.31	Average
6	0.502	41.58	56.00	-14.42	31.58	9.62	0.07	0.31	QP
7	0.529	37.73	46.00	-8.27	27.72	9.62	0.08	0.31	Average
8	0.529	40.59	56.00	-15.41	30.58	9.62	0.08	0.31	QP
9	0.555	36.79	46.00	-9.21	26.78	9.62	0.08	0.31	Average
10	0.555	39.29	56.00	-16.71	29.28	9.62	0.08	0.31	QP
11	0.582	36.98	46.00	-9.02	26.97	9.62	0.08	0.31	Average
12	0.582	39.24	56.00	-16.76	29.23	9.62	0.08	0.31	QP

Note 1: Level (dBuV) = Read Level (dBuV) + LISN Factor (dB) + Cable Loss (dB) + Aux (dB).

Note 2: Over Limit (dB) = Level (dBuV) - Limit Line (dBuV).



Modulation	11b	Test Freq. (MHz)	2437
Power Phase	Neutral		

Test by : Joe Liao      Temperature: 22°C      Humidity: 68%

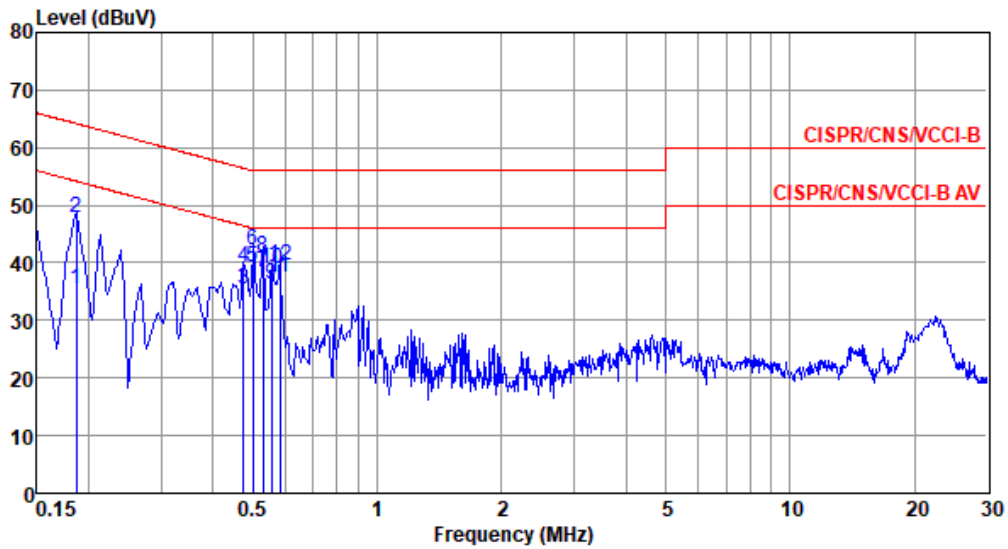

	Freq MHz	Level dBuV	Limit Line dBuV	Over Limit dB	Read Level dBuV	Factor dB	Cable loss dB	Aux dB	Remark
1	0.186	35.34	54.20	-18.86	25.46	9.63	0.06	0.19	Average
2	0.186	47.79	64.20	-16.41	37.91	9.63	0.06	0.19	QP
3	0.474	35.48	46.45	-10.97	25.48	9.62	0.07	0.31	Average
4	0.474	39.24	56.45	-17.21	29.24	9.62	0.07	0.31	QP
5*	0.500	39.23	46.00	-6.77	29.23	9.62	0.07	0.31	Average
6	0.500	42.35	56.00	-13.65	32.35	9.62	0.07	0.31	QP
7	0.529	38.31	46.00	-7.69	28.30	9.62	0.08	0.31	Average
8	0.529	41.11	56.00	-14.89	31.10	9.62	0.08	0.31	QP
9	0.555	36.25	46.00	-9.75	26.24	9.62	0.08	0.31	Average
10	0.555	38.94	56.00	-17.06	28.93	9.62	0.08	0.31	QP
11	0.582	37.37	46.00	-8.63	27.36	9.62	0.08	0.31	Average
12	0.582	39.54	56.00	-16.46	29.53	9.62	0.08	0.31	QP

Note 1: Level (dBuV) = Read Level (dBuV) + LISN Factor (dB) + Cable Loss (dB) + Aux (dB).  
 Note 2: Over Limit (dB) = Level (dBuV) - Limit Line (dBuV).



ST M.2, PCIe Module with PCB Dipole antenna

Modulation	11b	Test Freq. (MHz)	2437
Power Phase	Line		

Test by : Joe Liao      Temperature: 22°C      Humidity: 68%

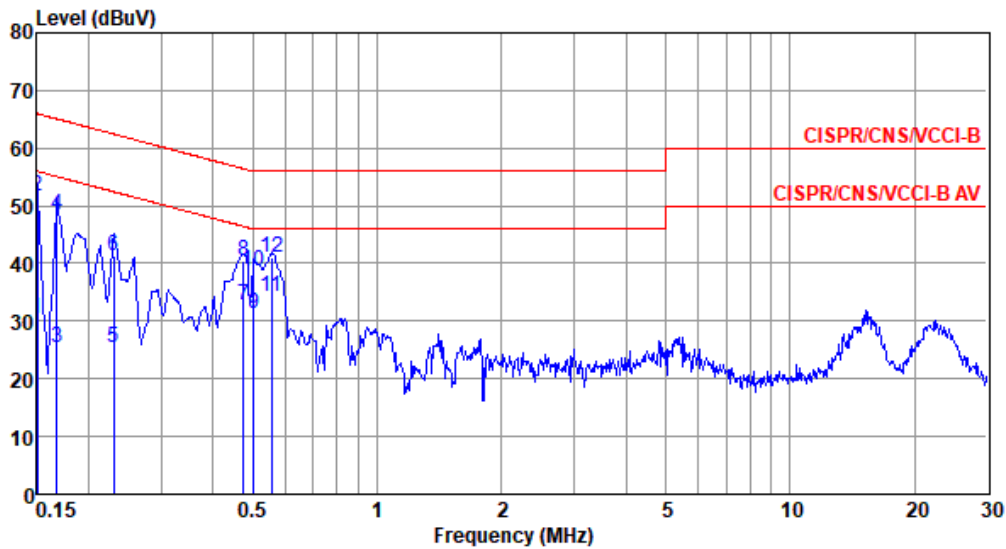

	Freq MHz	Level dBuV	Limit Line dBuV	Over Limit dB	Read Level dBuV	Factor dB	Cable loss dB	Aux dB	Remark
1	0.150	30.49	56.00	-25.51	20.62	9.63	0.06	0.18	Average
2	0.150	51.53	66.00	-14.47	41.66	9.63	0.06	0.18	QP
3	0.168	25.30	55.08	-29.78	15.43	9.63	0.06	0.18	Average
4	0.168	48.48	65.08	-16.60	38.61	9.63	0.06	0.18	QP
5	0.230	25.26	52.44	-27.18	15.37	9.62	0.06	0.21	Average
6	0.230	41.45	62.44	-20.99	31.56	9.62	0.06	0.21	QP
7	0.474	32.76	46.45	-13.69	22.76	9.62	0.07	0.31	Average
8	0.474	40.38	56.45	-16.07	30.38	9.62	0.07	0.31	QP
9	0.502	31.14	46.00	-14.86	21.14	9.62	0.07	0.31	Average
10	0.502	38.65	56.00	-17.35	28.65	9.62	0.07	0.31	QP
11*	0.555	34.27	46.00	-11.73	24.26	9.62	0.08	0.31	Average
12	0.555	41.15	56.00	-14.85	31.14	9.62	0.08	0.31	QP

Note 1: Level (dBuV) = Read Level (dBuV) + LISN Factor (dB) + Cable Loss (dB) + Aux (dB).

2: Over Limit (dB) = Level (dBuV) – Limit Line (dBuV).



Modulation	11b	Test Freq. (MHz)	2437
Power Phase	Neutral		

Test by : Joe Liao      Temperature: 22°C      Humidity: 68%

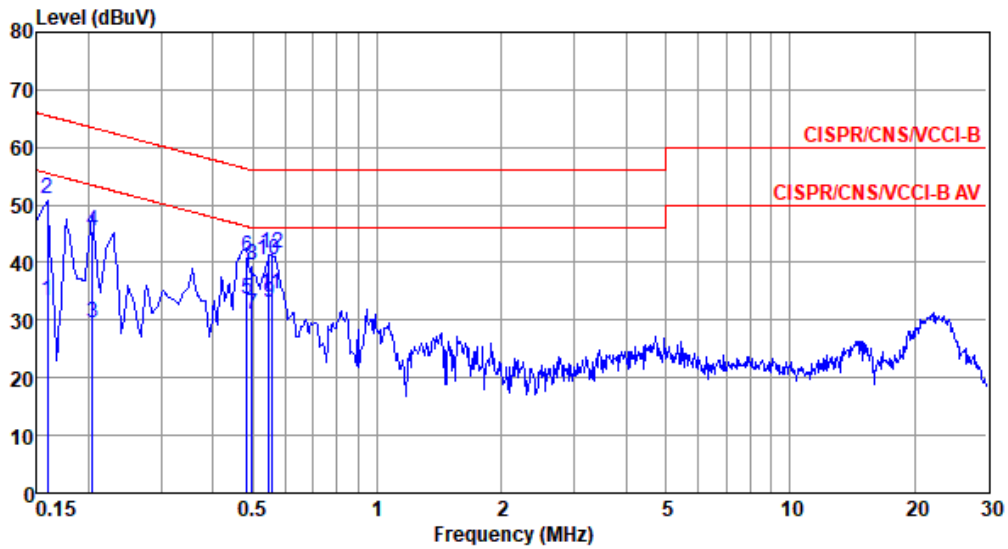

	Freq MHz	Level dBuV	Limit Line dBuV	Over Limit dB	Read Level dBuV	Factor dB	Cable loss dB	Aux dB	Remark
1	0.159	33.43	55.52	-22.09	23.56	9.63	0.06	0.18	Average
2	0.159	51.09	65.52	-14.43	41.22	9.63	0.06	0.18	QP
3	0.204	29.65	53.45	-23.80	19.77	9.63	0.06	0.19	Average
4	0.204	45.42	63.45	-18.03	35.54	9.63	0.06	0.19	QP
5	0.484	33.77	46.27	-12.50	23.77	9.62	0.07	0.31	Average
6	0.484	41.10	56.27	-15.17	31.10	9.62	0.07	0.31	QP
7	0.497	31.02	46.05	-15.03	21.02	9.62	0.07	0.31	Average
8	0.497	39.45	56.05	-16.60	29.45	9.62	0.07	0.31	QP
9	0.546	33.18	46.00	-12.82	23.17	9.62	0.08	0.31	Average
10	0.546	40.33	56.00	-15.67	30.32	9.62	0.08	0.31	QP
11*	0.555	34.59	46.00	-11.41	24.58	9.62	0.08	0.31	Average
12	0.555	41.49	56.00	-14.51	31.48	9.62	0.08	0.31	QP

Note 1: Level (dBuV) = Read Level (dBuV) + LISN Factor (dB) + Cable Loss (dB) + Aux (dB).  
 2: Over Limit (dB) = Level (dBuV) – Limit Line (dBuV).