

FCC C2PC Test Report

FCC ID : SQG-PINNACLE1
Equipment : LTE Modem
Model No. : Pinnacle 100
Brand Name : Laird Connectivity
Applicant : Laird Connectivity, Inc.
Address : W66N220 Commerce Court, Cedarburg,
Wisconsin 53012, USA
Standard : 47 CFR FCC Part 27
Received Date : Jun. 24, 2020
Tested Date : Nov. 05 ~ Nov. 13, 2020

We, International Certification Corp., would like to declare that the tested sample has been evaluated and in compliance with the requirement of the above standards. The test results contained in this report refer exclusively to the product. It may be duplicated completely for legal use with the approval of the applicant. It shall not be reproduced except in full without the written approval of our laboratory.

Reviewed by:

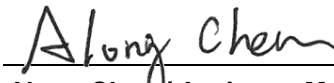

Along Chen / Assistant Manager

Approved by:



Gary Chang / Manager



Table of Contents

1	GENERAL DESCRIPTION	5
1.1	Information.....	5
1.2	Local Support Equipment List	8
1.3	Test Setup Chart	8
1.4	The Equipment List	9
1.5	Test Standards	10
1.6	Reference Guidance	10
1.7	Deviation from Test Standard and Measurement Procedure.....	10
1.8	Measurement Uncertainty	10
2	TEST CONFIGURATION	11
2.1	Testing Facility.....	11
2.2	The Worst Test Modes and Channel Details	12
3	TEST RESULTS.....	13
3.1	Effective Radiated Power	13
3.2	Radiated Emissions.....	22
4	TEST LABORATORY INFORMATION	29

Release Record

Report No.	Version	Description	Issued Date
FG950303-02P27	Rev. 01	Initial issue	Dec. 11, 2020

Summary of Test Results

FCC Rules	Test Items	Measured	Result
2.1046 27.50(b)(10) 27.50(c)(10)	Effective Radiated Power	Power[dBm]: LTE Band 12: 24.31 LTE Band 13: 23.27	Pass
2.1053 27.53(c) 27.53(g)	Radiated Emissions	Meet the requirement of limit	Pass
2.1053 27.53(f)	Radiated Spurious Emission in the 1559-1610MHz band	Meet the requirement of limit	Pass
2.1051 27.53(c) 27.53(g)	Conducted Emissions	Note	Pass
2.1051 27.53 (c) 27.53(g)	Band Edge	Note	Pass
2.1049	Occupied Bandwidth	Note	Pass
2.1055 / 27.54	Frequency Stability	Note	Pass

Note: Refers to test report of FCC ID: N7NHL78. Test report no.: RF181126C15B-2

Declaration of Conformity:
The test results with all measurement uncertainty excluded are presented in accordance with the regulation limits or requirements declared by manufacturers.
Comments and Explanations:
The declared of product specification for EUT presented in the report are provided by the manufacturer, and the manufacturer takes all the responsibilities for the accuracy of product specification.

1 General Description

1.1 Information

This report is issued as a Class II Permissive Change. The modification is adding two antennas and by software setting to enable LTE NB-IOT function.

1.1.1 Specification of the Equipment under Test (EUT)

Operating Frequency	699 MHz ~ 716 MHz 777 MHz ~ 787MHz
Modulation	QPSK, BPSK
UE category	NB-IoT

1.1.2 Antenna Details (New addition is marked in boldface.)

Ant. No.	Brand / Model	Type	Connector	Gain (dBi)	Operating Band
External					
1	Laird / DBA6927C1	Dipole	U.FL	0.5	LTE Band 12
				0.5	LTE Band 13
2	Laird / EFF6925A3S	Flex	U.FL	1.9	LTE Band 12
				1.9	LTE Band 13
3	ASC / RFDPA131000SMTB803	Dipole	U.FL	-0.22	LTE Band 12
				1	LTE Band 13
4	Laird / EFF6989A3S-19MHF1	Flex	U.FL	0.9	LTE Band 12
				0.9	LTE Band 13
5	Laird / EFF6060A3S-10MHF	Flex	U.FL	2.5	LTE Band 12
				2.5	LTE Band 13
Integrated					
4	Laird/110-00665	Stamped Metal	N/A	1.3	LTE Band 12
				1.3	LTE Band 13

1.1.3 EUT Operational Condition

Power Supply Type	3.7 Vdc
--------------------------	---------

1.1.4 Accessories

N/A

1.1.5 Operating Channel List

LTE Band 12		
---	Channel	Frequency (MHz)
Stand-alone	23012	699.2
	23095	707.5
	23178	715.8
LTE Band 13		
Stand-alone	23182	777.2
	23230	782
	23278	786.8

LTE Band 12		
Channel Bandwidth (MHz)	Channel	Frequency (MHz)
In-Band		
3	23018	699.8
3	23086	706.6
3	23172	715.2
Guard-Band		
5	23012	699.2
5	23071	705.1
5	23178	715.8
In-Band- NB-IoT PRB: 30		
10	23071	705.09
10	23105	708.49
10	23139	711.89
In-Band- NB-IoT PRB: 35		
10	23080	705.99
10	23114	709.39
10	23148	712.79

LTE Band 13		
Channel Bandwidth (MHz)	Channel	Frequency (MHz)
In-Band		
5	23188	777.8
5	23221	781.1
5	23272	786.2
Guard-Band		
5	23182	777.2
5	23206	779.6
5	23278	786.8
In-Band - NB-IoT PRB: 30		
10	23241	783.09
In-Band - NB-IoT PRB: 35		
10	23250	783.99

1.2 Local Support Equipment List

Support Equipment List					
No.	Equipment	Brand	Model	FCC ID	Remarks
1	Notebook	DELL	Latitude E6440	DoC	---
2	USB Cable	I-Gota	micro to A	---	---
3	50Ω terminator	---	---	---	---
4	Fixture	---	---	---	Provided by applicant.

1.3 Test Setup Chart

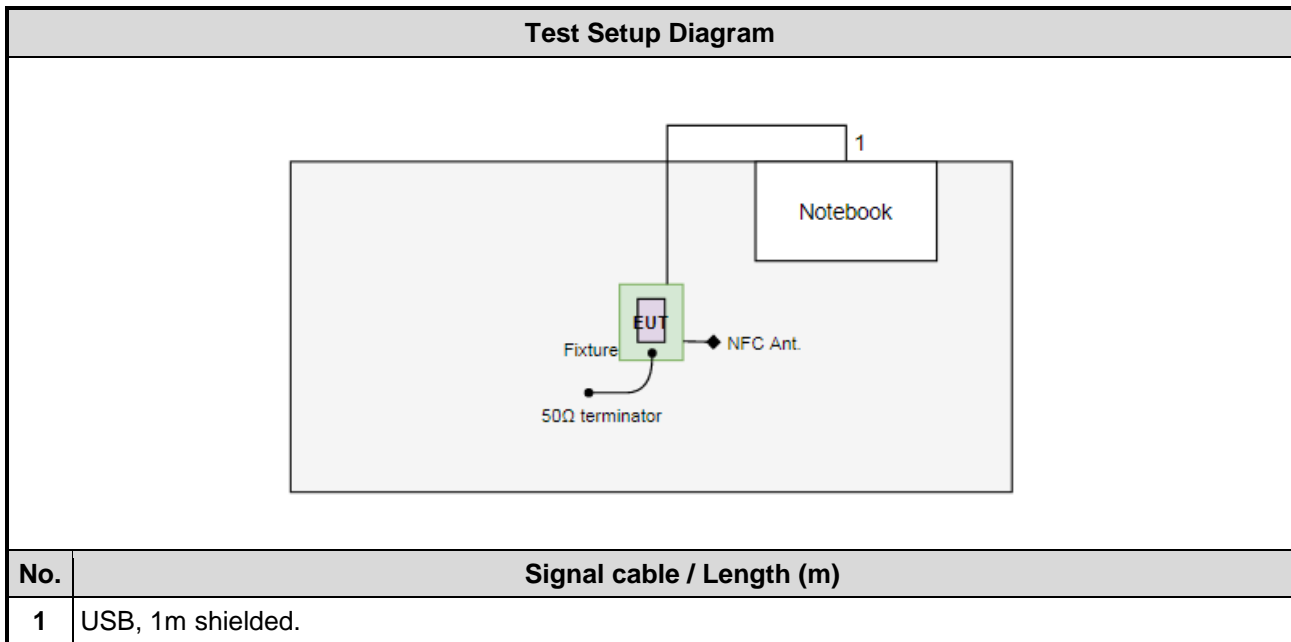

1.4 The Equipment List

Test Item	Radiated Emission				
Test Site	966 chamber1 / (03CH01-WS)				
Tested Date	Nov. 05 ~ Nov. 13, 2020				
Instrument	Brand	Model No.	Serial No.	Calibration Date	Calibration Until
Spectrum Analyzer	R&S	FSV40	101498	Dec. 17, 2019	Dec. 16, 2020
Receiver	R&S	ESR3	101657	Feb. 14, 2020	Feb. 13, 2021
Bilog Antenna	SCHWARZBECK	VULB9168	VULB9168-522	Jul. 10, 2020	Jul. 09, 2021
Horn Antenna 1G-18G	SCHWARZBECK	BBHA 9120 D	BBHA 9120 D 1096	Dec. 12, 2019	Dec. 11, 2020
Horn Antenna 18G-40G	SCHWARZBECK	BBHA 9170	BBHA 9170508	Dec. 25, 2019	Dec. 24, 2020
Loop Antenna	TESEQ	HLA 6120	31244	Mar. 16, 2020	Mar. 15, 2021
Loop Antenna Cable	KOAX KABEL	101354-BW	101354-BW	Oct. 06, 2020	Oct. 05, 2021
Preamplifier	EMC	EMC02325	980225	Jul. 03, 2020	Jul. 02, 2021
Preamplifier	Agilent	83017A	MY39501308	Sep. 26, 2020	Sep. 25, 2021
Preamplifier	EMC	EMC184045B	980192	Jul. 21, 2020	Jul. 20, 2021
RF Cable	EMC	EMC104-SM-SM-80 00	181106	Oct. 06, 2020	Oct. 05, 2021
RF Cable	HUBER+SUHNER	SUCOFLEX104	MY16019/4	Oct. 06, 2020	Oct. 05, 2021
RF Cable	HUBER+SUHNER	SUCOFLEX104	MY16014/4	Oct. 06, 2020	Oct. 05, 2021
LF cable 1M	EMC	EMCCFD400-NM-N M-1000	160502	Oct. 06, 2020	Oct. 05, 2021
LF cable 3M	Woken	CFD400NL-LW	CFD400NL-001	Oct. 06, 2020	Oct. 05, 2021
LF cable 11M	EMC	EMCCFD400-NW-N W-11000	200801	Oct. 06, 2020	Oct. 05, 2021
Measurement Software	AUDIX	e3	6.120210g	NA	NA

Note: Calibration Interval of instruments listed above is one year.

Test Item	RF Conducted				
Test Site	(TH01-WS)				
Tested Date	Nov. 10, 2020				
Instrument	Brand	Model No.	Serial No.	Calibration Date	Calibration Until
Spectrum Analyzer	R&S	FSV40	101063	Apr. 30, 2020	Apr. 29, 2021
Spectrum Analyzer	R&S	FSV40	101499	Jan. 09, 2020	Jan. 08, 2021
Power Meter	Anritsu	ML2495A	1241002	Nov. 04, 2020	Nov. 03, 2021
Power Sensor	Anritsu	MA2411B	1207366	Nov. 04, 2020	Nov. 03, 2021
DC POWER SOURCE	GW INSTEK	GPC-6030D	GES855395	Nov. 09, 2020	Nov. 08, 2021
Measurement Software	Sporton	Sporton_1	1.3.30	NA	NA

Note: Calibration Interval of instruments listed above is one year.

1.5 Test Standards

47 CFR FCC Part 27

ANSI C63.26-2015

1.6 Reference Guidance

FCC KDB 412172 D01 Determining ERP and EIRP v01r01

FCC KDB 971168 D01 Power Meas License Digital Systems v03r01

FCC KDB 971168 D02 Misc Rev Approv License Devices v02r01

1.7 Deviation from Test Standard and Measurement Procedure

None

1.8 Measurement Uncertainty

The measurement uncertainties given below are based on a 95% confidence level (based on a coverage factor ($k=2$)).

Measurement Uncertainty	
Parameters	Uncertainty
Radiated emission \leq 1GHz	± 3.41 dB
Radiated emission $>$ 1GHz	± 4.59 dB

2 Test Configuration

2.1 Testing Facility

Test Laboratory	International Certification Corp.
Test Site	03CH01-WS, TH01-WS
Address of Test Site	No. 3-1, Lane 6, Wen San 3rd St., Kwei Shan District, Tao Yuan City 333, Taiwan, R.O.C.

- FCC Designation No.: TW2732
- FCC site registration No.: 181692
- ISED#: 10807A
- CAB identifier: TW2732

2.2 The Worst Test Modes and Channel Details

LTE Band 12			
Test item	Mode	Modulation	Test channel
Effective Radiated Power	Stand-alone	BPSK / QPSK	23012 / 23095 / 23178
	In-Band	BPSK / QPSK	23018 / 23086 / 23172
	In-Band NB-IoT PRB: 30	BPSK / QPSK	23071 / 23105 / 23139
	In-Band NB-IoT PRB: 35	BPSK / QPSK	23080 / 23114 / 23148
	Guard-Band	BPSK / QPSK	23012 / 23071 / 23178
Radiated Emission \leq 1GHz	Stand-alone	BPSK	23095
Radiated Emission $>$ 1GHz	Stand-alone	BPSK	23012 / 23095 / 23178
Note:			
1. The EUT was pretested with 3 orientations placed on the table for the radiated emission measurement – X, Y, and Z-plane. The Y-plane results were found as the worst case and were shown in this report.			
2. 50 Ω terminators is connected to antenna port of EUT for radiated emission measurement.			

LTE Band 13			
Test item	Mode	Modulation	Test channel
E.R.P Conducted Emissions	Stand-alone	BPSK / QPSK	23182 / 23230 / 23278
	In-Band	BPSK / QPSK	23188 / 23221 / 23272
	In-Band NB-IoT PRB: 30	BPSK / QPSK	23241
	In-Band NB-IoT PRB: 35	BPSK / QPSK	23250
	Guard-Band	BPSK / QPSK	23182 / 23206 / 23278
Radiated Emission \leq 1GHz	Stand-alone	BPSK	23278
Radiated Emission $>$ 1GHz	Stand-alone	BPSK	23182 / 23230 / 23278
Note:			
1. The EUT was pretested with 3 orientations placed on the table for the radiated emission measurement – X, Y, and Z-plane. The Y-plane results were found as the worst case and were shown in this report.			
2. 50 Ω terminators is connected to antenna port of EUT for radiated emission measurement.			

3 Test Results

3.1 Effective Radiated Power

3.1.1 Limit of Effective Radiated Power

Portable stations (hand-held devices) are limited to 3 watts ERP.

3.1.2 Test Procedures

For E.R.P measurement

ERP can be calculated by below formula from KDB 412172 D01.

1. $EIRP = P_T + G_T - L_C$
 P_T = transmitter output power, in dBm.
 G_T = gain of the transmitting antenna, in dBi (EIRP).
 L_C = signal attenuation in the connecting cable between the transmitter and antenna, in dB.
2. $ERP = EIRP - 2.15 \text{ dB}$.

For Conducted power measurement

1. The EUT links up with simulator and is set to maximum output power level at low / middle / high channel.
2. Measure the output power of low / middle / high channel of the EUT

3.1.3 Test Setup

Conducted Power Measurement

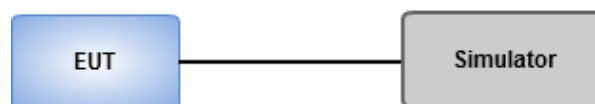

3.1.4 Test Result of Effective Radiated Power (dBm)

LTE Band 12

Stand-alone - LTE Band 12												
NUL	MUL	Frequency of Uplink (MHz)	Test Configuration Initial of Power			EUT		Antenna Gain (dBi)	E.I.R.P Power (dBm)	E.R.P Power (dBm)	E.R.P Power (W)	E.R.P Limit (W)
			Modulation	Ntones	Sub-carrier Spacing (kHz)	Cell Power (dBm/15 kHz)	Conducted Power (dBm)					
23012	0	699.2	BPSK	1@0	3.75	-110	23.79	2.5	26.29	24.14	0.259	3
			BPSK	1@0	15	-110	23.22	2.5	25.72	23.57	0.228	3
			QPSK	1@0	3.75	-110	23.68	2.5	26.18	24.03	0.253	3
			QPSK	1@0	15	-110	23.18	2.5	25.68	23.53	0.225	3
			QPSK	3@3	15	-110	22.82	2.5	25.32	23.17	0.207	3
			QPSK	12@0	15	-110	21.01	2.5	23.51	21.36	0.137	3
23095	0	707.5	BPSK	1@0	3.75	-110	23.91	2.5	26.41	24.26	0.267	3
			BPSK	1@0	15	-110	23.31	2.5	25.81	23.66	0.232	3
			BPSK	1@47	3.75	-110	23.96	2.5	26.46	24.31	0.270	3
			QPSK	1@0	3.75	-110	23.85	2.5	26.35	24.2	0.263	3
			QPSK	1@0	15	-110	23.23	2.5	25.73	23.58	0.228	3
			QPSK	1@11	15	-110	23.22	2.5	25.72	23.57	0.228	3
			QPSK	3@3	15	-110	22.93	2.5	25.43	23.28	0.213	3
23178	0	715.8	BPSK	1@47	3.75	-110	23.89	2.5	26.39	24.24	0.265	3
			BPSK	1@11	15	-110	23.25	2.5	25.75	23.6	0.229	3
			QPSK	1@47	3.75	-110	23.67	2.5	26.17	24.02	0.252	3
			QPSK	1@11	15	-110	23.19	2.5	25.69	23.54	0.226	3
			QPSK	3@3	15	-110	22.87	2.5	25.37	23.22	0.210	3
			QPSK	12@0	15	-110	21.06	2.5	23.56	21.41	0.138	3

Note1: EIRP = Conducted Output Power + Antenna Gain.

Note2: ERP = EIRP - 2.15.

In-Band - LTE Band 12, BW: 3												
NUL	MUL	Frequency of Uplink (MHz)	Test Configuration Initial of Power			EUT		Antenna Gain (dBi)	E.I.R.P Power (dBm)	E.R.P Power (dBm)	E.R.P Power (W)	E.R.P Limit (W)
			Modulation	Ntones	Sub-carrier Spacing (kHz)	Cell Power (dBm/15 kHz)	Conducted Power (dBm)					
23018	0	699.8	BPSK	1@0	3.75	-110	23.76	2.5	26.26	24.11	0.258	3
			QPSK	1@0	15	-110	23.06	2.5	25.56	23.41	0.219	3
			QPSK	3@3	15	-110	22.87	2.5	25.37	23.22	0.210	3
			QPSK	12@0	15	-110	21.05	2.5	23.55	21.4	0.138	3
23086	0	706.6	BPSK	1@0	3.75	-110	23.72	2.5	26.22	24.07	0.255	3
			BPSK	1@47	3.75	-110	23.75	2.5	26.25	24.1	0.257	3
			QPSK	1@0	15	-110	23.17	2.5	25.67	23.52	0.225	3
			QPSK	1@11	15	-110	23.13	2.5	25.63	23.48	0.223	3
			QPSK	3@3	15	-110	22.71	2.5	25.21	23.06	0.202	3
			QPSK	12@0	15	-110	20.91	2.5	23.41	21.26	0.134	3
23172	0	715.2	BPSK	1@47	3.75	-110	23.65	2.5	26.15	24	0.251	3
			QPSK	1@11	15	-110	23.01	2.5	25.51	23.36	0.217	3
			QPSK	3@3	15	-110	22.81	2.5	25.31	23.16	0.207	3
			QPSK	12@0	15	-110	20.98	2.5	23.48	21.33	0.136	3

Note1: EIRP = Conducted Output Power + Antenna Gain.

Note2: ERP = EIRP - 2.15.

In-Band - NB-IoT PRB: 30, LTE Band 12, BW: 10												
NUL	MUL	Frequency of Uplink (MHz)	Test Configuration Initial of Power			EUT		Antenna Gain (dBi)	E.I.R.P Power (dBm)	E.R.P Power (dBm)	E.R.P Power (W)	E.R.P Limit (W)
			Modulation	Ntones	Sub-carrier Spacing (kHz)	Cell Power (dBm/15 kHz)	Conducted Power (dBm)					
23071	-2	705.09	BPSK	1@0	3.75	-110	23.71	2.5	26.21	24.06	0.255	3
			QPSK	1@0	15	-110	23.02	2.5	25.52	23.37	0.217	3
			QPSK	3@3	15	-110	22.58	2.5	25.08	22.93	0.196	3
			QPSK	12@0	15	-110	20.75	2.5	23.25	21.1	0.129	3
23105	-2	708.49	BPSK	1@0	3.75	-110	23.72	2.5	26.22	24.07	0.255	3
			BPSK	1@47	3.75	-110	23.71	2.5	26.21	24.06	0.255	3
			QPSK	1@0	15	-110	23.01	2.5	25.51	23.36	0.217	3
			QPSK	1@11	15	-110	22.96	2.5	25.46	23.31	0.214	3
			QPSK	3@3	15	-110	22.83	2.5	25.33	23.18	0.208	3
			QPSK	12@0	15	-110	20.85	2.5	23.35	21.2	0.132	3
23139	-2	711.89	BPSK	1@47	3.75	-110	23.68	2.5	26.18	24.03	0.253	3
			QPSK	1@11	15	-110	23.02	2.5	25.52	23.37	0.217	3
			QPSK	3@3	15	-110	22.56	2.5	25.06	22.91	0.195	3
			QPSK	12@0	15	-110	20.75	2.5	23.25	21.1	0.129	3

Note1: EIRP = Conducted Output Power + Antenna Gain.

Note2: ERP = EIRP - 2.15.

In-Band - NB-IoT PRB: 35, LTE Band 12, BW: 10												
NUL	MUL	Frequency of Uplink (MHz)	Test Configuration Initial of Power			EUT		Antenna Gain (dBi)	E.I.R.P Power (dBm)	E.R.P Power (dBm)	E.R.P Power (W)	E.R.P Limit (W)
			Modulation	Ntones	Sub-carrier Spacing (kHz)	Cell Power (dBm/15 kHz)	Conducted Power (dBm)					
23080	-2	705.99	BPSK	1@0	3.75	-110	23.69	2.5	26.19	24.04	0.254	3
			QPSK	1@0	15	-110	22.97	2.5	25.47	23.32	0.215	3
			QPSK	3@3	15	-110	22.71	2.5	25.21	23.06	0.202	3
			QPSK	12@0	15	-110	20.87	2.5	23.37	21.22	0.132	3
23114	-2	709.39	BPSK	1@0	3.75	-110	23.71	2.5	26.21	24.06	0.255	3
			BPSK	1@47	3.75	-110	23.68	2.5	26.18	24.03	0.253	3
			QPSK	1@0	15	-110	22.95	2.5	25.45	23.3	0.214	3
			QPSK	1@11	15	-110	22.92	2.5	25.42	23.27	0.212	3
			QPSK	3@3	15	-110	22.71	2.5	25.21	23.06	0.202	3
			QPSK	12@0	15	-110	20.82	2.5	23.32	21.17	0.131	3
23148	-2	712.79	BPSK	1@47	3.75	-110	23.66	2.5	26.16	24.01	0.252	3
			QPSK	1@11	15	-110	22.89	2.5	25.39	23.24	0.211	3
			QPSK	3@3	15	-110	22.71	2.5	25.21	23.06	0.202	3
			QPSK	12@0	15	-110	20.88	2.5	23.38	21.23	0.133	3

Note1: EIRP = Conducted Output Power + Antenna Gain.

Note2: ERP = EIRP - 2.15.

Guard-Band - LTE Band 12, BW: 5												
NUL	MUL	Frequency of Uplink (MHz)	Test Configuration Initial of Power			EUT		Antenna Gain (dBi)	E.I.R.P Power (dBm)	E.R.P Power (dBm)	E.R.P Power (W)	E.R.P Limit (W)
			Modulation	Ntones	Sub-carrier Spacing (kHz)	Cell Power (dBm/15 kHz)	Conducted Power (dBm)					
23012	0	699.2	BPSK	1@0	3.75	-110	23.67	2.5	26.17	24.02	0.252	3
			QPSK	1@0	15	-110	22.98	2.5	25.48	23.33	0.215	3
			QPSK	3@3	15	-110	22.67	2.5	25.17	23.02	0.200	3
			QPSK	12@0	15	-110	20.72	2.5	23.22	21.07	0.128	3
23071	0	705.1	BPSK	1@0	3.75	-110	23.72	2.5	26.22	24.07	0.255	3
			BPSK	1@47	3.75	-110	23.72	2.5	26.22	24.07	0.255	3
			QPSK	1@0	15	-110	22.99	2.5	25.49	23.34	0.216	3
			QPSK	1@11	15	-110	22.95	2.5	25.45	23.3	0.214	3
			QPSK	3@3	15	-110	22.57	2.5	25.07	22.92	0.196	3
			QPSK	12@0	15	-110	20.73	2.5	23.23	21.08	0.128	3
23178	0	715.8	BPSK	1@47	3.75	-110	23.68	2.5	26.18	24.03	0.253	3
			QPSK	1@11	15	-110	23.02	2.5	25.52	23.37	0.217	3
			QPSK	3@3	15	-110	22.82	2.5	25.32	23.17	0.207	3
			QPSK	12@0	15	-110	20.95	2.5	23.45	21.3	0.135	3

Note1: EIRP = Conducted Output Power + Antenna Gain.

Note2: ERP = EIRP - 2.15.

LTE Band 13

Stand-alone - LTE Band 13												
NUL	MUL	Frequency of Uplink (MHz)	Test Configuration Initial of Power			EUT		Antenna Gain (dBi)	E.I.R.P Power (dBm)	E.R.P Power (dBm)	E.R.P Power (W)	E.R.P Limit (W)
			Modulation	Ntones	Sub-carrier Spacing (kHz)	Cell Power (dBm/15 kHz)	Conducted Power (dBm)					
23182	0	777.2	BPSK	1@0	3.75	-110	22.27	2.5	24.77	22.62	0.183	3
			BPSK	1@0	15	-110	22.86	2.5	25.36	23.21	0.209	3
			QPSK	1@0	3.75	-110	22.22	2.5	24.72	22.57	0.181	3
			QPSK	1@0	15	-110	22.73	2.5	25.23	23.08	0.203	3
			QPSK	3@3	15	-110	22.47	2.5	24.97	22.82	0.191	3
			QPSK	12@0	15	-110	20.65	2.5	23.15	21	0.126	3
23230	0	782	BPSK	1@0	3.75	-110	22.49	2.5	24.99	22.84	0.192	3
			BPSK	1@0	15	-110	22.89	2.5	25.39	23.24	0.211	3
			BPSK	1@47	3.75	-110	22.53	2.5	25.03	22.88	0.194	3
			QPSK	1@0	3.75	-110	22.45	2.5	24.95	22.8	0.191	3
			QPSK	1@0	15	-110	22.83	2.5	25.33	23.18	0.208	3
			QPSK	1@11	15	-110	22.81	2.5	25.31	23.16	0.207	3
			QPSK	3@3	15	-110	22.46	2.5	24.96	22.81	0.191	3
			QPSK	12@0	15	-110	20.65	2.5	23.15	21	0.126	3
23278	0	786.8	BPSK	1@47	3.75	-110	22.02	2.5	24.52	22.37	0.173	3
			BPSK	1@11	15	-110	22.92	2.5	25.42	23.27	0.212	3
			QPSK	1@47	3.75	-110	21.93	2.5	24.43	22.28	0.169	3
			QPSK	1@11	15	-110	22.88	2.5	25.38	23.23	0.210	3
			QPSK	3@3	15	-110	22.54	2.5	25.04	22.89	0.195	3
			QPSK	12@0	15	-110	20.75	2.5	23.25	21.1	0.129	3

Note1: EIRP = Conducted Output Power + Antenna Gain.

Note2: ERP = EIRP - 2.15.

In-Band - LTE Band 13, BW : 5												
NUL	MUL	Frequency of Uplink (MHz)	Test Configuration Initial of Power			EUT		Antenna Gain (dBi)	E.I.R.P Power (dBm)	E.R.P Power (dBm)	E.R.P Power (W)	E.R.P Limit (W)
			Modulation	Ntones	Sub-carrier Spacing (kHz)	Cell Power (dBm/15 kHz)	Conducted Power (dBm)					
23188	0	777.8	BPSK	1@0	3.75	-110	22.41	2.5	24.91	22.76	0.189	3
			QPSK	1@0	15	-110	22.82	2.5	25.32	23.17	0.207	3
			QPSK	3@3	15	-110	22.58	2.5	25.08	22.93	0.196	3
			QPSK	12@0	15	-110	20.75	2.5	23.25	21.1	0.129	3
23221	0	781.1	BPSK	1@0	3.75	-110	22.41	2.5	24.91	22.76	0.189	3
			BPSK	1@47	3.75	-110	22.45	2.5	24.95	22.8	0.191	3
			QPSK	1@0	15	-110	22.78	2.5	25.28	23.13	0.206	3
			QPSK	1@11	15	-110	22.81	2.5	25.31	23.16	0.207	3
			QPSK	3@3	15	-110	22.51	2.5	25.01	22.86	0.193	3
			QPSK	12@0	15	-110	20.66	2.5	23.16	21.01	0.126	3
23272	0	786.2	BPSK	1@47	3.75	-110	22.07	2.5	24.57	22.42	0.175	3
			QPSK	1@11	15	-110	22.84	2.5	25.34	23.19	0.208	3
			QPSK	3@3	15	-110	22.62	2.5	25.12	22.97	0.198	3
			QPSK	12@0	15	-110	20.73	2.5	23.23	21.08	0.128	3

Note1: EIRP = Conducted Output Power + Antenna Gain.

Note2: ERP = EIRP - 2.15.

In-Band - NB-IoT PRB: 30, LTE Band 13, BW: 10												
NUL	MUL	Frequency of Uplink (MHz)	Test Configuration Initial of Power			EUT		Antenna Gain (dBi)	E.I.R.P Power (dBm)	E.R.P Power (dBm)	E.R.P Power (W)	E.R.P Limit (W)
			Modulation	Ntones	Sub-carrier Spacing (kHz)	Cell Power (dBm/15 kHz)	Conducted Power (dBm)					
23241	-2	783.09	BPSK	1@0	3.75	-110	22.46	2.5	24.96	22.81	0.191	3
			BPSK	1@47	3.75	-110	22.52	2.5	25.02	22.87	0.194	3
			QPSK	1@0	15	-110	22.76	2.5	25.26	23.11	0.205	3
			QPSK	1@11	15	-110	22.73	2.5	25.23	23.08	0.203	3
			QPSK	3@3	15	-110	22.51	2.5	25.01	22.86	0.193	3
			QPSK	12@0	15	-110	20.73	2.5	23.23	21.08	0.128	3

Note1: EIRP = Conducted Output Power + Antenna Gain.

Note2: ERP = EIRP - 2.15.

In-Band - NB-IoT PRB: 35, LTE Band 13, BW: 10												
NUL	MUL	Frequency of Uplink (MHz)	Test Configuration Initial of Power			EUT		Antenna Gain (dBi)	E.I.R.P Power (dBm)	E.R.P Power (dBm)	E.R.P Power (W)	E.R.P Limit (W)
			Modulation	Ntones	Sub-carrier Spacing (kHz)	Cell Power (dBm/15 kHz)	Conducted Power (dBm)					
23250	-2	783.99	BPSK	1@0	3.75	-110	22.48	2.5	24.98	22.83	0.192	3
			BPSK	1@47	3.75	-110	22.49	2.5	24.99	22.84	0.192	3
			QPSK	1@0	15	-110	22.75	2.5	25.25	23.1	0.204	3
			QPSK	1@11	15	-110	22.73	2.5	25.23	23.08	0.203	3
			QPSK	3@3	15	-110	22.56	2.5	25.06	22.91	0.195	3
			QPSK	12@0	15	-110	20.71	2.5	23.21	21.06	0.128	3

Note1: EIRP = Conducted Output Power + Antenna Gain.

Note2: ERP = EIRP - 2.15.

Guard-Band - LTE Band 13, BW: 5												
NUL	MUL	Frequency of Uplink (MHz)	Test Configuration Initial of Power			EUT		Antenna Gain (dBi)	E.I.R.P Power (dBm)	E.R.P Power (dBm)	E.R.P Power (W)	E.R.P Limit (W)
			Modulation	Ntones	Sub-carrier Spacing (kHz)	Cell Power (dBm/15 kHz)	Conducted Power (dBm)					
23182	0	777.2	BPSK	1@0	3.75	-110	22.24	2.5	24.74	22.59	0.182	3
			QPSK	1@0	15	-110	22.71	2.5	25.21	23.06	0.202	3
			QPSK	3@3	15	-110	22.44	2.5	24.94	22.79	0.190	3
			QPSK	12@0	15	-110	20.61	2.5	23.11	20.96	0.125	3
23206	0	779.6	BPSK	1@0	3.75	-110	22.41	2.5	24.91	22.76	0.189	3
			BPSK	1@47	3.75	-110	22.43	2.5	24.93	22.78	0.190	3
			QPSK	1@0	15	-110	22.79	2.5	25.29	23.14	0.206	3
			QPSK	1@11	15	-110	22.77	2.5	25.27	23.12	0.205	3
			QPSK	3@3	15	-110	22.53	2.5	25.03	22.88	0.194	3
			QPSK	12@0	15	-110	20.53	2.5	23.03	20.88	0.122	3
23278	0	786.8	BPSK	1@47	3.75	-110	22.02	2.5	24.52	22.37	0.173	3
			QPSK	1@11	15	-110	22.81	2.5	25.31	23.16	0.207	3
			QPSK	3@3	15	-110	22.73	2.5	25.23	23.08	0.203	3
			QPSK	12@0	15	-110	20.84	2.5	23.34	21.19	0.132	3

Note1: EIRP = Conducted Output Power + Antenna Gain.

Note2: ERP = EIRP - 2.15.

3.2 Radiated Emissions

3.2.1 Limit of Radiated Emissions

The power of any emission outside of the authorized operating frequency ranges must be attenuated below the transmitting power (P) by a factor of at least $43 + 10 \log(P)$ dB equal to -13dBm.

3.2.2 Test Procedures

1. Measurement is made at a semi-anechoic chamber that incorporates a turntable allowing a EUT rotation of 360°. A continuously-rotating, remotely-controlled turntable is installed at the test site to support the EUT and facilitate determination of the direction of maximum radiation for each EUT emission frequency. For emissions testing at or below 1 GHz, the table height is 80 cm above the reference ground plane. For emission measurements above 1 GHz, the table height is 1.5 m.
2. Measurement is made with the antenna positioned in both the horizontal and vertical planes of polarization. The measurement antenna is varied in height (1m ~ 4m) above the reference ground plane to obtain the maximum signal strength. Distance between EUT and antenna is 3 m.
3. This investigation is performed with the EUT rotated 360°, the antenna height scanned between 1 m and 4 m, and the antenna rotated to repeat the measurements for both the horizontal and vertical antenna polarizations.
4. After finding the max radiated emission, substitution method will be used for getting effective radiated power. EUT will be removed and substitution antenna will be placed at same position. Signal generator will output CW signal to substitution antenna through a RF cable. Rotate turntable and move antenna to find maximum radiated emission. Adjust output power of signal generator to let the maximum radiated emission is same as step 3. Record the output power level.
5. $E.I.R.P = \text{output power of step 4} + \text{gain of substitution antenna} - \text{cable loss of RF cable}$. ERP can be calculated by below formula:
 $E.R.P = E.I.R.P - 2.15\text{dB}$.

3.2.3 Test Setup

Radiated Emissions below 1 GHz

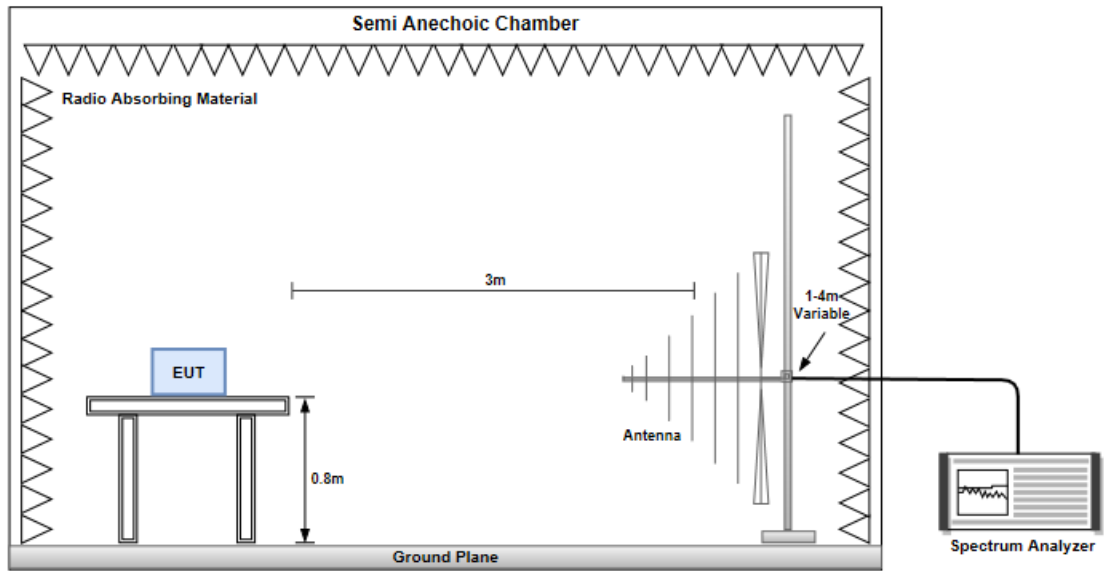

Radiated Emissions above 1 GHz

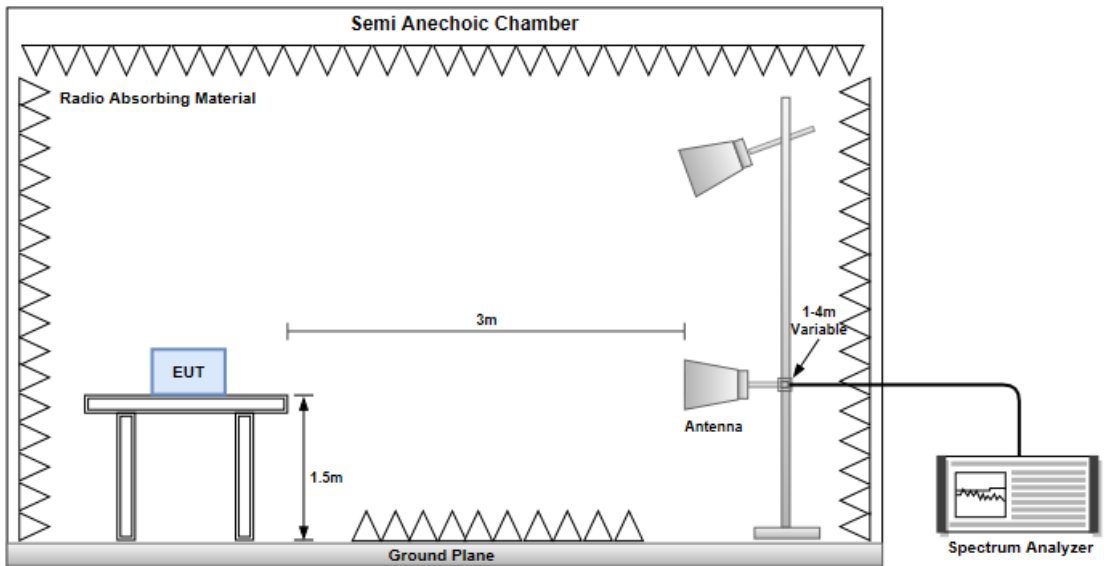

3.2.4 Test Result of Radiated Emissions below 1GHz

Ambient Condition	23°C / 63~68%	Tested By	Brad Wu
--------------------------	---------------	------------------	---------

LTE Band 12

Mode	LTE Band B12, Sub-Carrier specing : 3.75KHz , Ntones : 1@47, Channel : 23095						
Frequency (MHz)	Antenna Polarity	E.R.P (dBm)	Limit (dBm)	Margin (dB)	S.A Reading (dBm)	S.G Power Value (dBm)	Correction Factor (dB)
30	H	-67.17	-13	-54.17	-73.25	-45.57	-19.45
90.14	H	-67.48	-13	-54.48	-63.24	-60.42	-4.91
160.95	H	-65.9	-13	-52.9	-62.87	-57.55	-6.2
263.77	H	-73.05	-13	-60.05	-68.27	-69.64	-1.26
317.12	H	-71.89	-13	-58.89	-69.47	-68.53	-1.21
408.3	H	-69.91	-13	-56.91	-70.19	-66.52	-1.24
30	V	-70	-13	-57	-62.91	-48.4	-19.45
70.74	V	-65.89	-13	-52.89	-61.23	-53.43	-10.31
90.14	V	-68.54	-13	-55.54	-64.05	-61.48	-4.91
149.31	V	-67.88	-13	-54.88	-67.62	-59.2	-6.53
168.71	V	-67.16	-13	-54.16	-67.12	-59.39	-5.62
177.44	V	-69.12	-13	-56.12	-68.81	-62.01	-4.96

NOTE: ERP = S.G power value + correction factor - 2.15

LTE Band 13

Mode	LTE Band 13, Sub-Carrier specing : 15KHz , Ntones : 1@11, Channel : 23278						
Frequency (MHz)	Antenna Polarity	E.R.P (dBm)	Limit (dBm)	Margin (dB)	S.A Reading (dBm)	S.G Power Value (dBm)	Correction Factor (dB)
38.73	H	-70.08	-13	-57.08	-74.75	-50.17	-17.76
90.14	H	-68.03	-13	-55.03	-63.79	-60.97	-4.91
163.86	H	-65.29	-13	-52.29	-62	-57.16	-5.98
176.47	H	-54.06	-13	-41.06	-62.68	-46.88	-5.03
252.13	H	-59.63	-13	-46.63	-67.44	-56.22	-1.26
392.78	H	-44.91	-13	-31.91	-58.01	-41.55	-1.21
70.74	V	-71.1	-13	-58.1	-55.95	-58.64	-10.31
90.14	V	-68.12	-13	-55.12	-52.97	-61.06	-4.91
174.53	V	-67.58	-13	-54.58	-52.43	-60.25	-5.18
270.56	V	-68.65	-13	-55.65	-53.5	-65.24	-1.26
360.77	V	-68.39	-13	-55.39	-53.24	-65.12	-1.12
392.78	V	-60.53	-13	-47.53	-45.38	-57.17	-1.21

NOTE: ERP = S.G power value + correction factor - 2.15

3.2.5 Test Result of Radiated Emissions above 1GHz

Ambient Condition	23°C / 63~68%	Tested By	Brad Wu
--------------------------	---------------	------------------	---------

LTE Band 12

Mode							
LTE Band B12, Sub-Carrier specing : 3.75KHz, Ntones : 1@0, Channel : 23012							
Frequency (MHz)	Antenna Polarity	E.R.P (dBm)	Limit (dBm)	Margin (dB)	S.A Reading (dBm)	S.G Power Value (dBm)	Correction Factor (dB)
1398.22	H	-52.41	-13	-39.41	-56.8	-54.18	3.92
2097.33	H	-42.19	-13	-29.19	-49.23	-45.6	5.56
2796.44	H	-55.59	-13	-42.59	-64.41	-59.77	6.33
1398.22	V	-54.11	-13	-41.11	-58.21	-55.88	3.92
2097.33	V	-50.57	-13	-37.57	-57.6	-53.98	5.56
2796.44	V	-55.53	-13	-42.53	-64.43	-59.71	6.33

Mode							
LTE Band B12, Sub-Carrier specing : 3.75KHz , Ntones : 1@47, Channel : 23095							
Frequency (MHz)	Antenna Polarity	E.R.P (dBm)	Limit (dBm)	Margin (dB)	S.A Reading (dBm)	S.G Power Value (dBm)	Correction Factor (dB)
1415.18	H	-53.97	-13	-40.97	-58.36	-55.86	4.04
2122.77	H	-47.55	-13	-34.55	-54.79	-50.77	5.37
2830.36	H	-56.03	-13	-43.03	-65.01	-60.23	6.35
1415.18	V	-55.32	-13	-42.32	-59.45	-57.21	4.04
2122.77	V	-53.4	-13	-40.4	-60.66	-56.62	5.37
2830.36	V	-55.73	-13	-42.73	-64.74	-59.93	6.35

Mode							
LTE Band B12, Sub-Carrier specing : 3.75KHz , Ntones : 1@47, Channel : 23178							
Frequency (MHz)	Antenna Polarity	E.R.P (dBm)	Limit (dBm)	Margin (dB)	S.A Reading (dBm)	S.G Power Value (dBm)	Correction Factor (dB)
1431.78	H	-53.4	-13	-40.4	-57.76	-55.43	4.18
2147.67	H	-47.26	-13	-34.26	-54.68	-50.31	5.2
2863.56	H	-55.79	-13	-42.79	-64.94	-60.03	6.39
1431.78	V	-55.57	-13	-42.57	-59.71	-57.6	4.18
2147.67	V	-52.83	-13	-39.83	-60.3	-55.88	5.2
2863.56	V	-55.5	-13	-42.5	-64.6	-59.74	6.39

NOTE: ERP = S.G power value + correction factor - 2.15.

LTE Band 13

Mode	LTE Band 13, Sub-Carrier specing : 15KHz , Ntones : 1@0, Channel : 23182						
Frequency (MHz)	Antenna Polarity	E.R.P (dBm)	Limit (dBm)	Margin (dB)	S.A Reading (dBm)	S.G Power Value (dBm)	Correction Factor (dB)
1554.22	H	-52.61	-13	-39.61	-60.11	-56.07	5.61
3108.44	H	-53.1	-13	-40.1	-63.33	-57.47	6.52
3885.55	H	-53.2	-13	-40.2	-66.14	-58	6.95
1554.22	V	-52.6	-13	-39.6	-60.42	-56.06	5.61
3108.44	V	-53.57	-13	-40.57	-63.62	-57.94	6.52
3885.55	V	-53.01	-13	-40.01	-65.93	-57.81	6.95

Mode	LTE Band 13, Sub-Carrier specing : 15KHz , Ntones : 1@0, Channel : 23230						
Frequency (MHz)	Antenna Polarity	E.R.P (dBm)	Limit (dBm)	Margin (dB)	S.A Reading (dBm)	S.G Power Value (dBm)	Correction Factor (dB)
2345.73	H	-53	-13	-40	-60.46	-56.54	5.69
3127.64	H	-53.35	-13	-40.35	-63.65	-57.72	6.52
3909.55	H	-53.43	-13	-40.43	-66.2	-58.22	6.94
2345.73	V	-53.12	-13	-40.12	-60.93	-56.66	5.69
3127.64	V	-53.8	-13	-40.8	-63.95	-58.17	6.52
3909.55	V	-53.07	-13	-40.07	-65.86	-57.86	6.94

Mode	LTE Band 13, Sub-Carrier specing : 15KHz , Ntones : 1@11, Channel : 23278						
Frequency (MHz)	Antenna Polarity	E.R.P (dBm)	Limit (dBm)	Margin (dB)	S.A Reading (dBm)	S.G Power Value (dBm)	Correction Factor (dB)
2360.67	H	-53.11	-13	-40.11	-60.53	-56.74	5.78
3147.56	H	-53.47	-13	-40.47	-63.83	-57.83	6.51
3934.45	H	-53.21	-13	-40.21	-65.8	-58	6.94
2360.67	V	-52.6	-13	-39.6	-60.4	-56.23	5.78
3147.56	V	-53.5	-13	-40.5	-63.74	-57.86	6.51
3934.45	V	-52.96	-13	-39.96	-65.61	-57.75	6.94

NOTE: ERP = S.G power value + correction factor - 2.15

3.2.6 Test Result of Radiated Emissions in the 1559-1610MHz band

Ambient Condition	23°C / 63~68%	Tested By	Brad Wu
--------------------------	---------------	------------------	---------

Mode		LTE Band 13, Sub-Carrier specing : 15KHz , Ntones : 1@0 ,Channel : 23230					
Frequency (MHz)	Antenna Polarity	E.I.R.P (dBm)	Limit (dBm)	Margin (dB)	S.A Reading (dBm)	S.G Power Value (dBm)	Correction Factor (dB)
1563.82	H	-53.9	-40	-13.9	-60.06	-59.17	5.27
1563.82	V	-55.99	-40	-15.99	-62.25	-61.26	5.27

Mode		LTE Band 13, Sub-Carrier specing : 15KHz , Ntones : 1@11 ,Channel : 23278					
Frequency (MHz)	Antenna Polarity	E.I.R.P (dBm)	Limit (dBm)	Margin (dB)	S.A Reading (dBm)	S.G Power Value (dBm)	Correction Factor (dB)
1573.78	H	-53.98	-40	-13.98	-60.09	-59.33	5.35
1573.78	V	-55.58	-40	-15.58	-61.82	-60.93	5.35

NOTE: EIRP = S.G power value + correction factor

4 Test laboratory information

Established in 2012, ICC provides foremost EMC & RF Testing and advisory consultation services by our skilled engineers and technicians. Our services employ a wide variety of advanced edge test equipment and one of the widest certification extents in the business.

International Certification Corp (EMC and Wireless Communication Laboratory), it is our definitive objective is to institute long term, trust-based associations with our clients. The expectation we set up with our clients is based on outstanding service, practical expertise and devotion to a certified value structure. Our passion is to grant our clients with best EMC / RF services by oriented knowledgeable and accommodating staff.

Our Test sites are located at Linkou District and Kwei Shan District. Location map can be found on our website <http://www.icertifi.com.tw>.

Linkou

Tel: 886-2-2601-1640

No. 30-2, Ding Fwu Tsuen, Lin
Kou District, New Taipei City,
Taiwan, R.O.C.

Kwei Shan

Tel: 886-3-271-8666

No. 3-1, Lane 6, Wen San 3rd St.,
Kwei Shan District, Tao Yuan City
333, Taiwan, R.O.C.

Kwei Shan Site II

Tel: 886-3-271-8640

No. 14-1, Lane 19, Wen San 3rd
St., Kwei Shan District, Tao Yuan
City 333, Taiwan, R.O.C..

If you have any suggestion, please feel free to contact us as below information

Tel: 886-3-271-8666

Fax: 886-3-318-0155

Email: ICC_Service@icertifi.com.tw

==END==