

# FCC Test Report

**FCC ID** : SQG-MT320  
**Equipment** : WiFi 6 + Bluetooth 5.4 Module  
**Model No.** : Sona MT320  
**Brand Name** : Laird Connectivity  
**Applicant** : Laird Connectivity LLC  
**Address** : W66N220 Commerce Court, Cedarburg, WI  
53012 United States Of America  
**Standard** : 47 CFR FCC Part 15.247  
**Received Date** : Sep. 25, 2023  
**Tested Date** : Oct. 17 ~ Dec. 08, 2023

We, International Certification Corporation, would like to declare that the tested sample has been evaluated and in compliance with the requirement of the above standards. The test results contained in this report refer exclusively to the product. It shall not be reproduced except in full without the written approval of our laboratory.

Reviewed by:

Approved by:

  
\_\_\_\_\_  
Along Chen / Assistant Manager

  
\_\_\_\_\_  
Gary Chang / Manager

---

## Table of Contents

<b>1</b>	<b>GENERAL DESCRIPTION .....</b>	<b>5</b>
1.1	Information.....	5
1.2	Local Support Equipment List .....	9
1.3	Test Setup Chart .....	9
1.4	The Equipment List .....	11
1.5	Test Standards .....	12
1.6	Reference Guidance .....	12
1.7	Deviation from Test Standard and Measurement Procedure.....	12
1.8	Measurement Uncertainty .....	12
<b>2</b>	<b>TEST CONFIGURATION.....</b>	<b>13</b>
2.1	Testing Facility .....	13
2.2	The Worst Test Modes and Channel Details .....	14
2.3	Directional gain.....	15
<b>3</b>	<b>TRANSMITTER TEST RESULTS .....</b>	<b>16</b>
3.1	6dB and Occupied Bandwidth.....	16
3.2	Conducted Output Power .....	17
3.3	Power Spectral Density .....	18
3.4	Unwanted Emissions into Restricted Frequency Bands .....	19
3.5	Emissions in Non-Restricted Frequency Bands.....	21
3.6	AC Power Line Conducted Emissions .....	22
<b>4</b>	<b>TEST LABORATORY INFORMATION .....</b>	<b>23</b>

**Appendix A. 6dB and Occupied Bandwidth**

**Appendix B. Conducted Output Power**

**Appendix C. Power Spectral Density**

**Appendix D. Unwanted Emissions into Restricted Frequency Bands**

**Appendix E. Emissions in Non-Restricted Frequency Bands**

**Appendix F. AC Power Line Conducted Emissions**

---

## Release Record

Report No.	Version	Description	Issued Date
FR392501-1AC	Rev. 01	Initial issue	Jan. 23, 2024
FR392501-1AC	Rev. 02	Product name changed	Feb. 08, 2024

## Summary of Test Results

FCC Rules	Test Items	Measured	Result
15.207	AC Power Line Conducted Emission	[dBuV]: 0.408MHz 32.26 (Margin -15.42dB) - AV	Pass
15.247(d) 15.209	Unwanted Emissions	[dBuV/m at 3m]: 14472.00MHz 45.23 (Margin -8.77dB) - AV	Pass
15.247(b)(3)	Conducted Output Power	Max Power [dBm]: <b>Non-beamforming mode</b> 28.43 <b>Beamforming mode</b> 25.42	Pass
15.247(a)(2)	6dB Bandwidth	Meet the requirement of limit	Pass
15.247(e)	Power Spectral Density	Meet the requirement of limit	Pass
15.203	Antenna Requirement	Meet the requirement of limit	Pass

### Declaration of Conformity:

The test results with all measurement uncertainty excluded are presented in accordance with the regulation limits or requirements declared by manufacturers.

### Comments and Explanations:

The declared of product specification for EUT presented in the report are provided by the manufacturer, and the manufacturer takes all the responsibilities for the accuracy of product specification.

# 1 General Description

## 1.1 Information

### 1.1.1 Product Details

The two configurations of the EUT are shown on the following:

Brand Name	Model Name	Description
Laird Connectivity	Sona MT320	MT320-SC (MHF4 connector on module)
		MT320-ST (RF trace variant)

### 1.1.2 Specification of the Equipment under Test (EUT)

RF General Information					
Frequency Range (MHz)	IEEE Std. 802.11	Ch. Freq. (MHz)	Channel Number	Transmit Chains (N <sub>TX</sub> )	Data Rate / MCS
2400-2483.5	b	2412-2462	1-11 [11]	2	1-11 Mbps
2400-2483.5	g	2412-2462	1-11 [11]	2	6-54 Mbps
2400-2483.5	n (HT20)	2412-2462	1-11 [11]	2	MCS 0-15
2400-2483.5	n (HT40)	2422-2452	3-9 [7]	2	MCS 0-15
2400-2483.5	ax (HE20)	2412-2462	1-11 [11]	2	MCS 0-11
2400-2483.5	ax (HE40)	2422-2452	3-9 [7]	2	MCS 0-11

Note 1: RF output power specifies that Maximum Peak Conducted Output Power.  
 Note 2: DSSS-DBPSK, DQPSK, CCK modulation  
 OFDM/OFDMA- BPSK, QPSK, 16QAM, 64QAM, 256QAM and 1024QAM modulation.  
 Note 3: 802.11ax supports beamforming function.  
 Note 4: 802.11ax supports full RU and partial RU configuration. Test results of partial RU configuration are recorded in this report. Refers to report no.: FR392501AC for test results of full RU configuration.

### 1.1.3 Antenna Details

Ant. No.	Manufacturer	Model	Part Number	Type	Connector	Gain (dBi)	
						2.4GHz	5GHz
1	Laird Connectivity	FlexMIMO 6E	EFD2471A3S-10 MH4L	PIFA	MHF4L	2.2	3.8
2	Laird Connectivity	FlexPIFA 6E	EFB2471A3S-10 MH4L	PIFA	MHF4L	2.2	3.9
3	Laird Connectivity	Mini NanoBlade Flex 6 GHz	EMF2471A3S-10 MH4L	PCB Dipole	MHF4L	2.4	4.4
4	Joymax Electronics	Dipole 6E	TWX-100BRS3B	Dipole	RP-SMA	2	4

### 1.1.4 Power Supply Type of Equipment under Test (EUT)

<b>Power Supply Type</b>	3.3Vdc from host
--------------------------	------------------

### 1.1.5 Accessories

N/A

### 1.1.6 Channel List

Frequency band (MHz)		2400~2483.5	
802.11 b / g / n HT20 / ax HE20		802.11n HT40 / ax HE40	
Channel	Frequency(MHz)	Channel	Frequency(MHz)
1	2412	3	2422
2	2417	4	2427
3	2422	5	2432
4	2427	6	2437
5	2432	7	2442
6	2437	8	2447
7	2442	9	2452
8	2447	---	---
9	2452	---	---
10	2457	---	---
11	2462	---	---

### 1.1.7 Test Tool and Duty Cycle

<b>Test Tool</b>	QATool, version: 0.0.2.85		
<b>Duty Cycle and Duty Factor</b>	<b>Mode</b>	<b>Duty Cycle (%)</b>	<b>Duty Factor (dB)</b>
	ax HE20 RU26	90.50%	0.43
	ax HE20 RU52	90.15%	0.45
	ax HE20 RU106	88.63%	0.52
	ax HE40 RU26	90.06%	0.45
	ax HE40 RU52	89.00%	0.51
	ax HE40 RU106	89.15%	0.50
	ax HE40 RU242	78.45%	1.05

## 1.1.8 Power Index of Test Tool

### SC Module

Modulation Mode	Test Frequency (MHz)	Power Index
ax HE20 RU26	2412	7.5
ax HE20 RU26	2437	12.5
ax HE20 RU26	2462	9.5
ax HE20 RU52	2412	9
ax HE20 RU52	2437	13.5
ax HE20 RU52	2462	11
ax HE20 RU106	2412	10
ax HE20 RU106	2437	12.5
ax HE20 RU106	2462	9
ax HE40 RU26	2422	8
ax HE40 RU26	2437	12
ax HE40 RU26	2452	11
ax HE40 RU52	2422	8
ax HE40 RU52	2437	11.5
ax HE40 RU52	2452	11
ax HE40 RU106	2422	8
ax HE40 RU106	2437	11.5
ax HE40 RU106	2452	11
ax HE40 RU242	2422	8
ax HE40 RU242	2437	11.5
ax HE40 RU242	2452	10.5

**ST Module**

<b>Modulation Mode</b>	<b>Test Frequency (MHz)</b>	<b>Power Index</b>
ax HE20 RU26	2412	7.5
ax HE20 RU26	2437	12.5
ax HE20 RU26	2462	9
ax HE20 RU52	2412	9
ax HE20 RU52	2437	13
ax HE20 RU52	2462	10.5
ax HE20 RU106	2412	10
ax HE20 RU106	2437	12.5
ax HE20 RU106	2462	8.5
ax HE40 RU26	2422	8
ax HE40 RU26	2437	12
ax HE40 RU26	2452	10.5
ax HE40 RU52	2422	8
ax HE40 RU52	2437	11.5
ax HE40 RU52	2452	10.5
ax HE40 RU106	2422	8
ax HE40 RU106	2437	11
ax HE40 RU106	2452	10.5
ax HE40 RU242	2422	8
ax HE40 RU242	2437	11.5
ax HE40 RU242	2452	10



## 1.2 Local Support Equipment List

Support Equipment List					
No.	Equipment	Brand	Model	FCC ID	Remarks
1	Laptop	DELL	Latitude 5400	DoC	---
2	Fixture	---	---	---	Provided by applicant.
3	Fixture's adapter	---	---	---	Provided by applicant. I/P: 100-240Vac, 1.5A, 50-60Hz O/P: 5.0V 3.0A
4	Carrier board	---	---	---	Provided by applicant.
5	50Ω terminator	---	---	---	---

Note: The support laptop was disconnected from EUT and was removed from testing table after sending command to EUT to transmit continuously.

## 1.3 Test Setup Chart

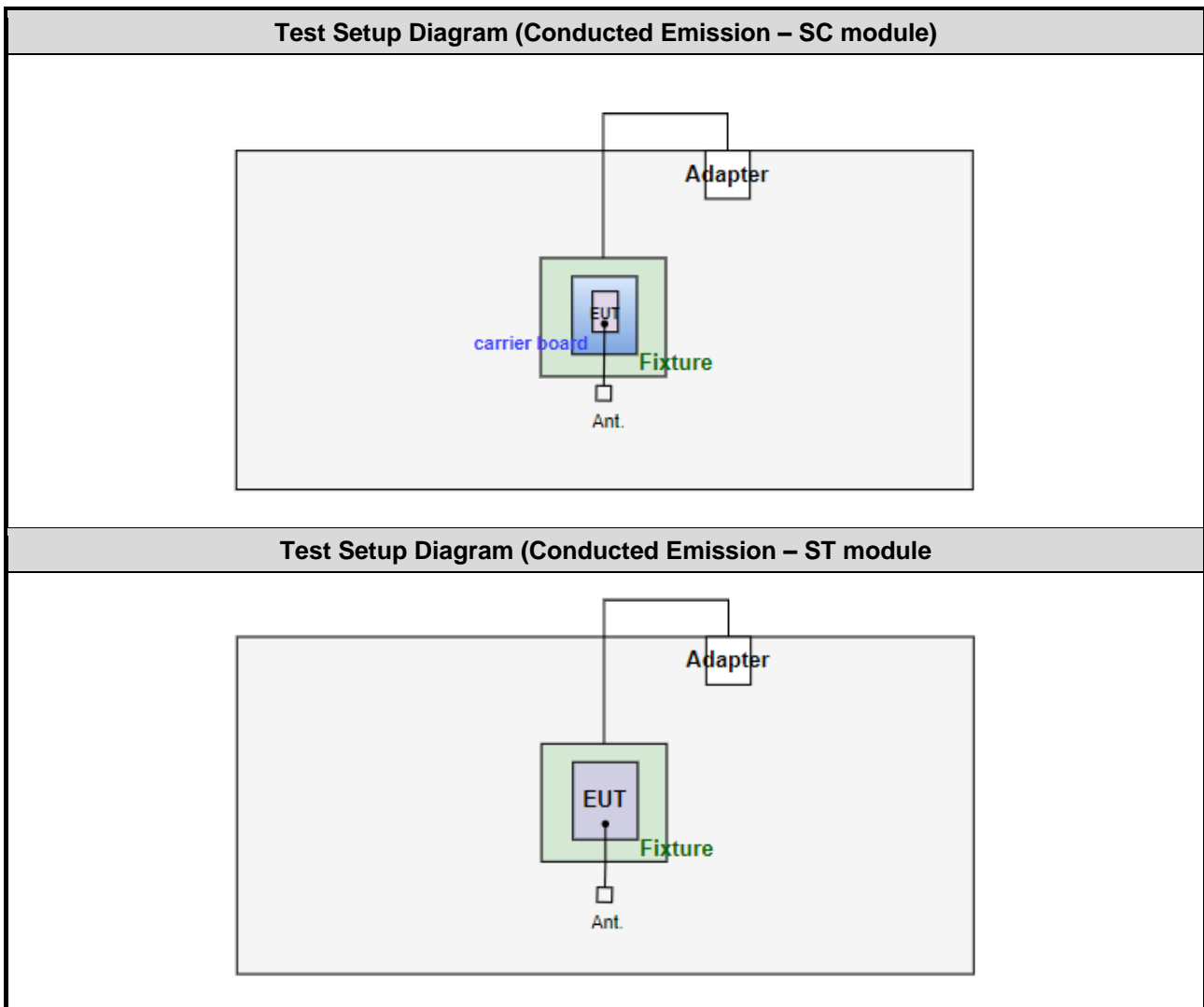

**Test Setup Diagram (Radiated Emission – SC module)**

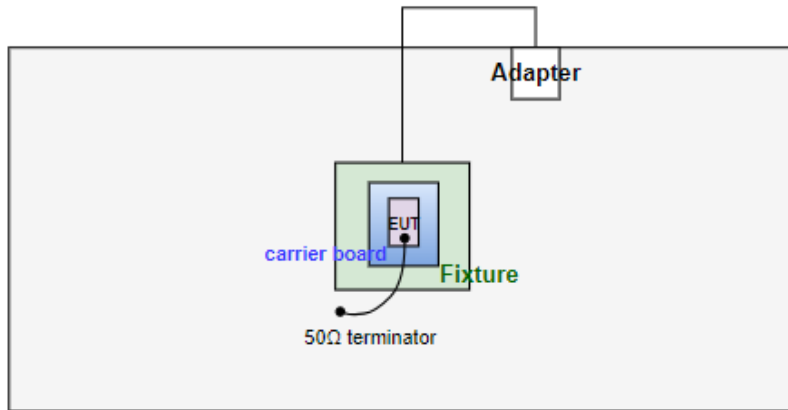

**Test Setup Diagram (Radiated Emission – ST module)**

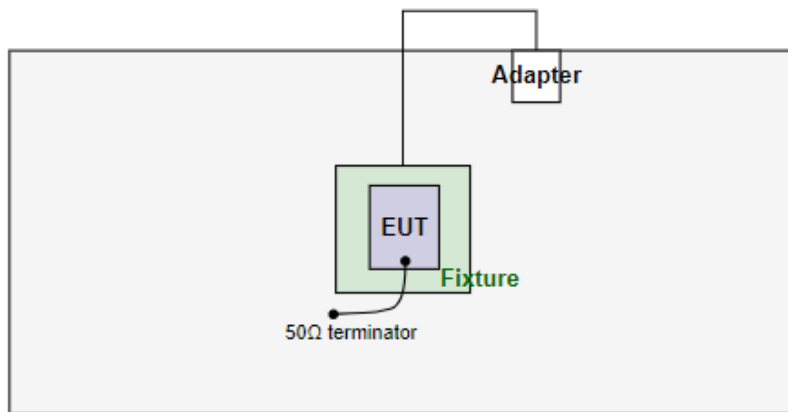

## 1.4 The Equipment List

<b>Test Item</b>	Conducted Emission				
<b>Test Site</b>	Conduction room 1 / (CO01-WS)				
<b>Tested Date</b>	Dec. 08, 2023				
<b>Instrument</b>	<b>Brand</b>	<b>Model No.</b>	<b>Serial No.</b>	<b>Calibration Date</b>	<b>Calibration Until</b>
Receiver	R&S	ESR3	101658	Feb. 17, 2023	Feb. 16, 2024
LISN	R&S	ENV216	101579	May. 09, 2023	May. 08, 2024
LISN (Support Unit)	SCHWARZBECK	Schwarzbeck 8127	8127667	Jan. 03, 2023	Jan. 02, 2024
RF Cable-CON	Woken	CFD200-NL	CFD200-NL-001	Oct. 11, 2023	Oct. 10, 2024
50 ohm terminal (Support Unit)	NA	50	01	Jun. 14, 2023	Jun. 13, 2024
Measurement Software	AUDIX	e3	6.120210k	NA	NA
Note: Calibration Interval of instruments listed above is one year.					

<b>Test Item</b>	Radiated Emission				
<b>Test Site</b>	966 chamber1 / (03CH01-WS)				
<b>Tested Date</b>	Oct. 24 ~ Oct. 25, 2023				
<b>Instrument</b>	<b>Brand</b>	<b>Model No.</b>	<b>Serial No.</b>	<b>Calibration Date</b>	<b>Calibration Until</b>
Receiver	R&S	ESR3	101657	Mar. 03, 2023	Mar. 02, 2024
Spectrum Analyzer	R&S	FSV40	101498	Nov. 21, 2022	Nov. 20, 2023
Loop Antenna	R&S	HFH2-Z2	100330	Nov. 01, 2022	Oct. 31, 2023
Bilog Antenna	SCHWARZBECK	VULB9168	VULB9168-522	Jul. 31, 2023	Jul. 30, 2024
Horn Antenna 1G-18G	SCHWARZBECK	BBHA 9120 D	BBHA 9120 D 1096	Nov. 25, 2022	Nov. 24, 2023
Horn Antenna 18G-40G	SCHWARZBECK	BBHA 9170	BBHA 9170517	Oct. 27, 2022	Oct. 26, 2023
Preamplifier	EMC	EMC02325	980225	Jun. 28, 2023	Jun. 27, 2024
Preamplifier	EMC	EMC118A45SE	980898	Jul. 14, 2023	Jul. 13, 2024
Preamplifier	EMC	EMC184045SE	980903	Jul. 17, 2023	Jul. 16, 2024
Loop Antenna Cable	KOAX KABEL	101354-BW	101354-BW	Oct. 03, 2023	Oct. 02, 2024
LF cable 3M	Woken	CFD400NL-LW	CFD400NL-001	Oct. 03, 2023	Oct. 02, 2024
LF cable 11M	EMC	EMCCFD400-NW-NW-1 1000	200801	Oct. 03, 2023	Oct. 02, 2024
LF cable 1M	EMC	EMCCFD400-NM-NM-1 000	160502	Oct. 03, 2023	Oct. 02, 2024
RF Cable	EMC	EMC104-35M-35M-8000	210920	Oct. 03, 2023	Oct. 02, 2024
RF Cable	EMC	EMC104-35M-35M-3000	210922	Oct. 03, 2023	Oct. 02, 2024
Measurement Software	AUDIX	e3	6.120210g	NA	NA
Note: Calibration Interval of instruments listed above is one year.					

<b>Test Item</b>	RF Conducted				
<b>Test Site</b>	(TH01-WS)				
<b>Tested Date</b>	Oct. 17 ~ Nov. 28, 2023				
<b>Instrument</b>	<b>Brand</b>	<b>Model No.</b>	<b>Serial No.</b>	<b>Calibration Date</b>	<b>Calibration Until</b>
Spectrum Analyzer	R&S	FSV40	101910	Apr. 14, 2023	Apr. 13, 2024
Power Meter	Anritsu	ML2495A	1241001	Jan. 11, 2023	Jan. 10, 2024
Power Sensor	Anritsu	MA2411B	1911228	Jan. 11, 2023	Jan. 10, 2024
Attenuator	Pasternack	PE7005-10	10-2	Oct. 05, 2023	Oct. 04, 2024
HIGHPASS FILTER 3.1-18G	WHK	WHK3.1/18G-10SS	39	Oct. 05, 2023	Oct. 04, 2024
LOWPASS FILTER	WI	WLKS1100-12SS	2	Oct. 05, 2023	Oct. 04, 2024
Measurement Software	Sporton	SENSE-15247_DTS	V5.11	NA	NA
Note: Calibration Interval of instruments listed above is one year.					

## 1.5 Test Standards

47 CFR FCC Part 15.247  
ANSI C63.10-2013

## 1.6 Reference Guidance

FCC KDB 558074 D01 15.247 Meas Guidance v05r02  
FCC KDB 662911 D01 Multiple Transmitter Output v02r01

## 1.7 Deviation from Test Standard and Measurement Procedure

None

## 1.8 Measurement Uncertainty

The measurement uncertainties given below are based on a 95% confidence level (based on a coverage factor ( $k=2$ )).

Measurement Uncertainty	
Parameters	Uncertainty
Bandwidth	±34.130 Hz
Conducted power	±0.808 dB
Power density	±0.583 dB
Conducted emission	±2.715 dB
AC conducted emission	±2.92 dB
Unwanted Emission ≤ 1GHz	±3.41 dB
Unwanted Emission > 1GHz	±4.59 dB

## 2 Test Configuration

### 2.1 Testing Facility

<b>Test Laboratory</b>	International Certification Corporation
<b>Test Site</b>	CO01-WS, 03CH01-WS, TH01-WS
<b>Address of Test Site</b>	No.3-1, Lane 6, Wen San 3rd St., Kwei Shan Dist., Tao Yuan City 33381, Taiwan (R.O.C.)

- FCC Designation No.: TW2732
- FCC site registration No.: 181692
- ISED#: 10807A
- CAB identifier: TW2732

## 2.2 The Worst Test Modes and Channel Details

Test item	Modulation Mode	Test Frequency (MHz)	Data Rate	Test method	Mode	Test Configuration	Note
<b>Non-beamforming mode</b>							
AC Power Line Conducted Emission	ax HE20 RU52	2437	MCS 0	Conducted	TX	1	-
Unwanted Emissions ≤ 1GHz	ax HE20 RU52	2437	MCS 0	Radiated	TX	1, 2	Note 2
Unwanted Emissions >1GHz	ax HE20 RU26 ax HE20 RU52 ax HE20 RU106	2412 / 2437 / 2462	MCS 0	Radiated	TX	1	Note 2
	ax HE40 RU26 ax HE40 RU52 ax HE40 RU106 ax HE40 RU242	2422 / 2437 / 2452					
	ax HE20 RU106	2412	MCS 0	Radiated	TX	2	Note 2
Unwanted Emissions ≤ 1GHz	ax HE20 RU52	2437	MCS 0	Conducted	TX	1, 2	-
Unwanted Emissions >1GHz	ax HE20 RU26 ax HE20 RU52 ax HE20 RU106	2412 / 2437 / 2462	MCS 0	Conducted	TX	1	-
	ax HE40 RU26 ax HE40 RU52 ax HE40 RU106 ax HE40 RU242	2422 / 2437 / 2452					
	ax HE40 RU26	2452	MCS 0	Conducted	TX	2	-
Conducted Output Power	ax HE20 RU26 ax HE20 RU52 ax HE20 RU106	2412 / 2437 / 2462	MCS 0	Conducted	TX	1, 2	-
	ax HE40 RU26 ax HE40 RU52 ax HE40 RU106 ax HE40 RU242	2422 / 2437 / 2452					
6dB bandwidth Power spectral density	ax HE20 RU26 ax HE20 RU52 ax HE20 RU106	2412 / 2437 / 2462	MCS 0	Conducted	TX	1	-
	ax HE40 RU26 ax HE40 RU52 ax HE40 RU106 ax HE40 RU242	2422 / 2437 / 2452					
<b>NOTE:</b>							
1. The EUT was pretested with 3 orientations placed on the table for the radiated emission measurement – X, Y, and Z-plane. The <b>Y-plane</b> result was found as the worst case and was shown in this report.							
2. The 50Ω terminator is connected to antenna port of EUT for radiated emission measurement.							
3. Test configurations are listed as below: Configuration 1: SC Module Configuration 2: ST Module							

Test item	Modulation Mode	Test Frequency (MHz)	Data Rate	Test method	Mode	Test Configuration	Note
<b>Beamforming mode</b>							
Conducted Output Power	ax HE20 RU26 ax HE20 RU52 ax HE20 RU106	2412 / 2437 / 2462	MCS 0	Conducted	TX	1, 2	-
	ax HE40 RU26 ax HE40 RU52 ax HE40 RU106 ax HE40 RU242	2422 / 2437 / 2452					
<b>NOTE:</b>							
1. The EUT was pretested with 3 orientations placed on the table for the radiated emission measurement – X, Y, and Z-plane. The <b>Y-plane</b> result was found as the worst case and was shown in this report.							
2. Beamforming mode is calculated not measured. The calculation method is conducted power of non-beamforming – 3.01 dB.							
3. Test configurations are listed as below: Configuration 1: SC Module Configuration 2: ST Module							

## 2.3 Directional gain

Directional gain is calculated by following formula from FCC KDB 662911 D01 section F)2)f)(i)

Directional gain =  $G_{ANT} + \text{Array Gain}$ ;

For Power measurement (Non-Beamforming)

Array gain = 0 dB for  $N_{ANT} \leq 4$ ;

For Power spectral density / out of band emission (conducted measurement) / Power measurement (Beamforming)

Array gain =  $10 \cdot \log(N_{ANT}/N_{SS})$  dB;

Directional gain is calculated as below

Test item	$G_{ANT}$ (dBi)	Array gain (dB)	Directional gain (dBi)
Output power (Non-Beamforming)	2.4	0	2.4
Output power (Beamforming)	2.4	3.01	5.41
Power spectral density	2.4	3.01	5.41
Out of band emission(conducted measurement)	2.4	3.01	5.41

### 3 Transmitter Test Results

#### 3.1 6dB and Occupied Bandwidth

##### 3.1.1 Limit of 6dB Bandwidth

The minimum 6dB bandwidth shall be at least 500 kHz.

##### 3.1.2 Test Procedures

###### 6dB Bandwidth

1. Set resolution bandwidth (RBW) = 100 kHz, Video bandwidth = 300 kHz.
2. Detector = Peak, Trace mode = max hold.
3. Sweep = auto couple, Allow the trace to stabilize.
4. Measure the maximum width of the emission that is constrained by the frequencies associated with the two outermost amplitude points (upper and lower) that are attenuated by 6dB relative to the maximum level measured in the fundamental emission.

###### Occupied Bandwidth

1. Set resolution bandwidth (RBW) = 1% ~ 5 % of OBW, Video bandwidth = 3 x RBW
2. Detector = Sample, Trace mode = max hold.
3. Sweep = auto couple, Allow the trace to stabilize.
4. Use the OBW measurement function of spectrum analyzer to measure the occupied bandwidth.

##### 3.1.3 Test Setup

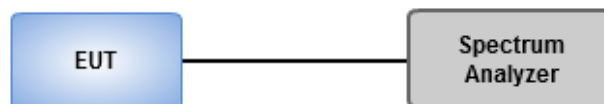

##### 3.1.4 Test Results

<b>Ambient Condition</b>	22-23°C / 65-67%	<b>Tested By</b>	Akun Chung
--------------------------	------------------	------------------	------------

Refer to Appendix A.



## 3.2 Conducted Output Power

### 3.2.1 Limit of Conducted Output Power

Conducted power shall not exceed 1Watt.

Antenna gain  $\leq$  6dBi, no any corresponding reduction is in output power limit.

Antenna gain  $>$  6dBi

Non Fixed, point to point operations.

The conducted output power from the intentional radiator shall be reduced by the amount in dB that the directional gain of the antenna exceeds 6 dB

Fixed, point to point operations

Systems operating in the 2400–2483.5 MHz band that are used exclusively for fixed, point-to-point Operations, maximum peak output power of the intentional radiator is reduced by 1 dB for every 3 dB that the directional gain of the antenna exceeds 6 dBi.

### 3.2.2 Test Procedures

A broadband RF power meter is used for output power measurement. The video bandwidth of power meter is greater than DTS bandwidth of EUT. If duty cycle of test signal is not 100 %, trigger and gating function of power meter will be enabled to capture transmission burst for measuring output power.

### 3.2.3 Test Setup



### 3.2.4 Test Results

<b>Ambient Condition</b>	22-23°C / 65-67%	<b>Tested By</b>	Akun Chung
--------------------------	------------------	------------------	------------

Refer to Appendix B.

### 3.3 Power Spectral Density

#### 3.3.1 Limit of Power Spectral Density

Power spectral density shall not be greater than 8 dBm in any 3 kHz band.

#### 3.3.2 Test Procedures

##### Peak PSD

1. Set the RBW = 3 kHz, VBW = 10 kHz.
2. Detector = Peak, Sweep time = auto couple.
3. Trace mode = max hold, allow trace to fully stabilize.
4. Use the peak marker function to determine the maximum amplitude level.

##### Average PSD, duty cycle $\geq$ 98%

1. Set the RBW = 3 kHz, VBW = 10 kHz.
2. Detector = RMS, Sweep time = auto couple.
3. Sweep time = auto couple.
4. Employ trace averaging (RMS) mode over a minimum of 100 traces.
5. Use the peak marker function to determine the maximum amplitude level.

##### Average PSD, duty cycle $<$ 98%

1. Set the RBW = 3 kHz, VBW = 10 kHz
2. Detector = RMS, Sweep time = auto couple.
3. Sweep time = auto couple.
4. Employ trace averaging (RMS) mode over a minimum of 100 traces.
5. Use the peak marker function to determine the maximum amplitude level.
6. Add  $10 \log (1/x)$ , where x is the duty cycle.

#### 3.3.3 Test Setup

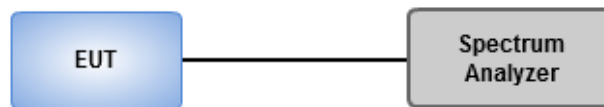

#### 3.3.4 Test Results

<b>Ambient Condition</b>	22-23°C / 65-67%	<b>Tested By</b>	Akun Chung
--------------------------	------------------	------------------	------------

Refer to Appendix C.

## 3.4 Unwanted Emissions into Restricted Frequency Bands

### 3.4.1 Limit of Unwanted Emissions into Restricted Frequency Bands

Restricted Band Emissions Limit			
Frequency Range (MHz)	Field Strength (uV/m)	Field Strength (dBuV/m)	Measure Distance (m)
0.009~0.490	2400/F(kHz)	48.5 - 13.8	300
0.490~1.705	24000/F(kHz)	33.8 - 23	30
1.705~30.0	30	29	30
30~88	100	40	3
88~216	150	43.5	3
216~960	200	46	3
Above 960	500	54	3

**Note 1:**  
Quasi-Peak value is measured for frequency below 1GHz except for 9–90 kHz, 110–490 kHz frequency band. Peak and average value are measured for frequency above 1GHz. The limit on average radio frequency emission is as above table. The limit on peak radio frequency emissions is 20 dB above the maximum permitted average emission limit

**Note 2:**  
Measurements may be performed at a distance other than what is specified provided. When performing measurements at a distance other than that specified, the results shall be extrapolated to the specified distance using an extrapolation factor as below, Frequency at or above 30 MHz: 20 dB/decade Frequency below 30 MHz: 40 dB/decade.

### 3.4.2 Test Procedures

1. Measurement is made at a semi-anechoic chamber that incorporates a turntable allowing a EUT rotation of 360°. A continuously-rotating, remotely-controlled turntable is installed at the test site to support the EUT and facilitate determination of the direction of maximum radiation for each EUT emission frequency. The EUT is placed at test table. For emissions testing at or below 1 GHz, the table height is 80 cm above the reference ground plane. For emission measurements above 1 GHz, the table height is 1.5 m
2. Measurement is made with the antenna positioned in both the horizontal and vertical planes of polarization. The measurement antenna is varied in height (1m ~ 4m) above the reference ground plane to obtain the maximum signal strength. Distance between EUT and antenna is 3 m.
3. This investigation is performed with the EUT rotated 360°, the antenna height scanned between 1 m and 4 m, and the antenna rotated to repeat the measurements for both the horizontal and vertical antenna polarizations.

**Note:**

1. 120kHz measurement bandwidth of test receiver and Quasi-peak detector is for radiated emission below 1GHz.
2. RBW=1MHz, VBW=3MHz and Peak detector is for peak measured value of radiated emission above 1GHz.
3. RBW=1MHz, VBW=1/T and Peak detector is for average measured value of radiated emission above 1GHz.

### 3.4.3 Test Setup

#### Radiated Emissions below 1 GHz

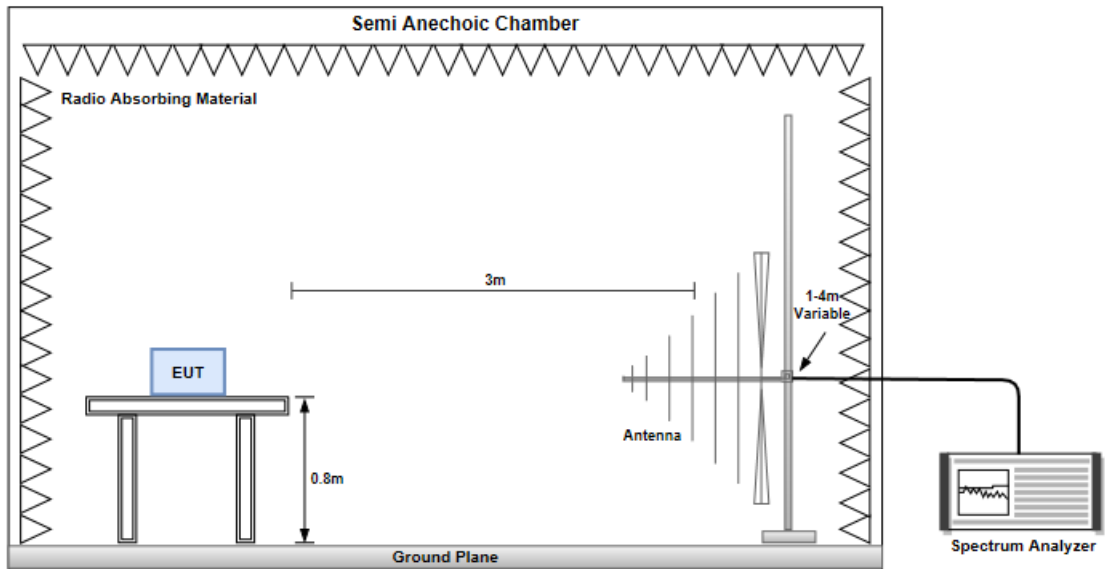

#### Radiated Emissions above 1 GHz

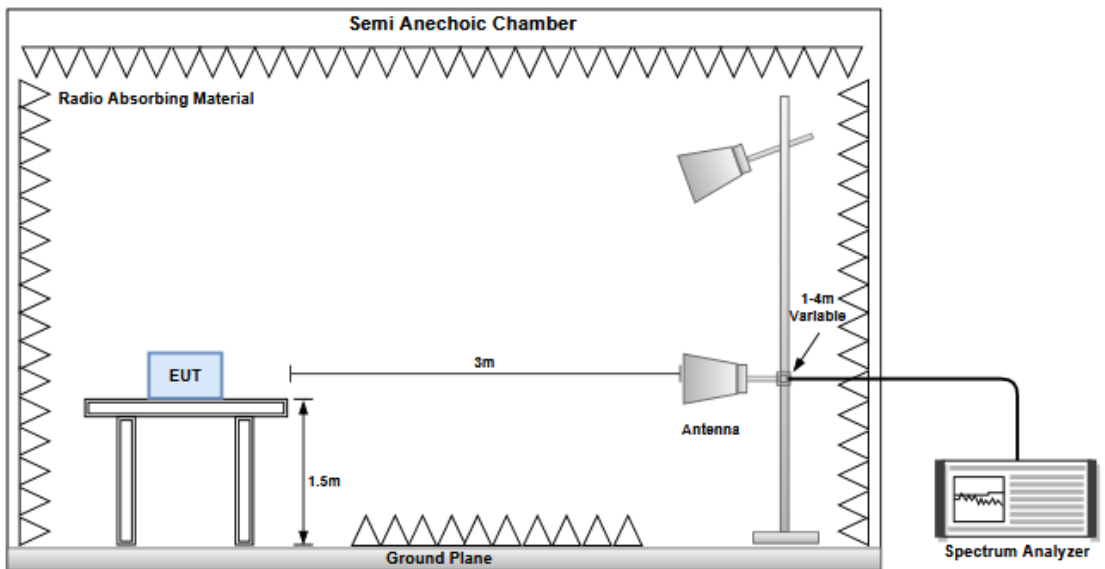

### 3.4.4 Test Results

Refer to Appendix D.

## 3.5 Emissions in Non-Restricted Frequency Bands

### 3.5.1 Emissions in Non-Restricted Frequency Bands Limit

Peak power in any 100 kHz bandwidth outside of the authorized frequency band shall be attenuated by at least 20 dB relative to the maximum in-band peak PSD level in 100 kHz.

### 3.5.2 Test Procedures

#### Reference level measurement

1. Set RBW=100kHz, VBW = 300kHz , Detector = Peak, Sweep time = Auto
2. Trace = max hold , Allow Trace to fully stabilize
3. Use the peak marker function to determine the maximum PSD level

#### Emission level measurement

1. Set RBW=100kHz, VBW = 300kHz , Detector = Peak, Sweep time = Auto
2. Trace = max hold , Allow Trace to fully stabilize
3. Scan Frequency range is up to 25GHz
4. Use the peak marker function to determine the maximum amplitude level

### 3.5.3 Test Setup

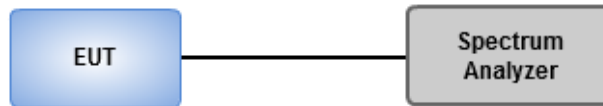

### 3.5.4 Test Results

<b>Ambient Condition</b>	22-23°C / 65-67%	<b>Tested By</b>	Akun Chung
--------------------------	------------------	------------------	------------

Refer to Appendix E.

## 3.6 AC Power Line Conducted Emissions

### 3.6.1 Limit of AC Power Line Conducted Emissions

Conducted Emissions Limit		
Frequency Emission (MHz)	Quasi-Peak	Average
0.15-0.5	66 - 56 *	56 - 46 *
0.5-5	56	46
5-30	60	50

Note 1: \* Decreases with the logarithm of the frequency.

### 3.6.2 Test Procedures

1. The device is placed on a test table, raised 80 cm above the reference ground plane. The vertical conducting plane is located 40 cm to the rear of the device.
2. The device is connected to line impedance stabilization network (LISN) and other accessories are connected to other LISN. Measured levels of AC power line conducted emission are across the 50  $\Omega$  LISN port.
3. AC conducted emission measurements is made over frequency range from 150 kHz to 30 MHz.
4. This measurement was performed with AC 120V / 60Hz.

### 3.6.3 Test Setup

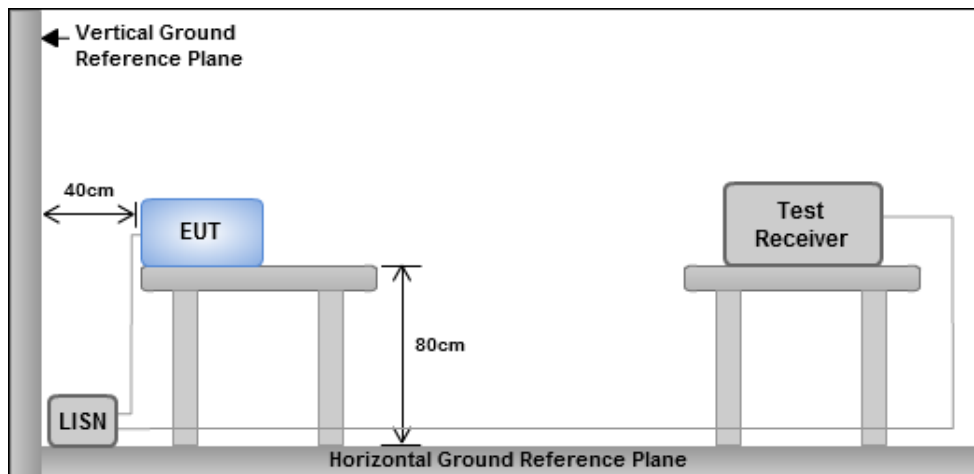

- Note: 1. Support units were connected to second LISN.  
 2. Both of LISNs (AMN) are 80 cm from EUT and at least 80 cm from other units and other metal planes

### 3.6.4 Test Results

Refer to Appendix F.

## 4 Test laboratory information

Established in 2012, ICC provides foremost EMC & RF Testing and advisory consultation services by our skilled engineers and technicians. Our services employ a wide variety of advanced edge test equipment and one of the widest certification extents in the business.

International Certification Corporation (EMC and Wireless Communication Laboratory), it is our definitive objective is to institute long term, trust-based associations with our clients. The expectation we set up with our clients is based on outstanding service, practical expertise and devotion to a certified value structure. Our passion is to grant our clients with best EMC / RF services by oriented knowledgeable and accommodating staff.

Our Test sites are located at Linkou District and Kwei Shan District. Location map can be found on our website <http://www.icertifi.com.tw>.

### **Linkou**

Tel: 886-2-2601-1640

No.30-2, Ding Fwu Tsuen, Lin Kou  
District, New Taipei City, Taiwan  
(R.O.C.)

### **Kwei Shan**

Tel: 886-3-271-8666

No.3-1, Lane 6, Wen San 3rd  
St., Kwei Shan Dist., Tao Yuan  
City 33381, Taiwan (R.O.C.)  
No.2-1, Lane 6, Wen San 3rd  
St., Kwei Shan Dist., Tao Yuan  
City 33381, Taiwan (R.O.C.)

### **Kwei Shan Site II**

Tel: 886-3-271-8640

No.14-1, Lane 19, Wen San 3rd  
St., Kwei Shan Dist., Tao Yuan  
City 33381, Taiwan (R.O.C.)

If you have any suggestion, please feel free to contact us as below information.

Tel: 886-3-271-8666

Fax: 886-3-318-0345

Email: ICC\_Service@icertifi.com.tw

==END==



Summary

Mode	Max-N dB (Hz)	Max-OBW (Hz)	ITU-Code	Min-N dB (Hz)	Min-OBW (Hz)
2.4-2.4835GHz	-	-	-	-	-
802.11ax HEW20_RU26_Index3_20MHz_Nss1,(MCS0)_2TX	2.075M	16.967M	17M0D1D	2.025M	16.768M
802.11ax HEW20_RU52_Index38_20MHz_Nss1,(MCS0)_2TX	15.05M	17.026M	17M0D1D	12.825M	16.794M
802.11ax HEW20_RU106_Index53_20MHz_Nss1,(MCS0)_2TX	17.75M	18.303M	18M3D1D	17.1M	17.999M
802.11ax HEW40_RU26_Index12_40MHz_Nss1,(MCS0)_2TX	2.1M	17.22M	17M2D1D	2M	16.993M
802.11ax HEW40_RU52_Index42_40MHz_Nss1,(MCS0)_2TX	15.05M	17.274M	17M3D1D	15M	17.088M
802.11ax HEW40_RU106_Index54_40MHz_Nss1,(MCS0)_2TX	17.45M	19.073M	19M1D1D	17.1M	17.932M
802.11ax HEW40_RU242_Index61_40MHz_Nss1,(MCS0)_2TX	18.85M	19.384M	19M4D1D	18.75M	19.006M

Max-N dB = Maximum 6dB down bandwidth; Max-OBW = Maximum 99% occupied bandwidth;  
 Min-N dB = Minimum 6dB down bandwidth; Min-OBW = Minimum 99% occupied bandwidth

Result

Mode	Result	Limit (Hz)	Port 1-N dB (Hz)	Port 1-OBW (Hz)	Port 2-N dB (Hz)	Port 2-OBW (Hz)
802.11ax HEW20_RU26_Index3_20MHz_Nss1,(MCS0)_2TX	-	-	-	-	-	-
2412MHz	Pass	500k	2.025M	16.872M	2.05M	16.768M
2437MHz	Pass	500k	2.075M	16.924M	2.075M	16.967M
2462MHz	Pass	500k	2.075M	16.929M	2.075M	16.933M
802.11ax HEW20_RU52_Index38_20MHz_Nss1,(MCS0)_2TX	-	-	-	-	-	-
2412MHz	Pass	500k	15.05M	16.874M	12.825M	16.794M
2437MHz	Pass	500k	15.025M	17.026M	15.025M	16.93M
2462MHz	Pass	500k	15M	17.001M	15.025M	16.93M
802.11ax HEW20_RU106_Index53_20MHz_Nss1,(MCS0)_2TX	-	-	-	-	-	-
2412MHz	Pass	500k	17.1M	18.033M	17.125M	17.999M
2437MHz	Pass	500k	17.15M	18.289M	17.15M	18.18M
2462MHz	Pass	500k	17.75M	18.303M	17.1M	18.165M
802.11ax HEW40_RU26_Index12_40MHz_Nss1,(MCS0)_2TX	-	-	-	-	-	-
2422MHz	Pass	500k	2.1M	17.212M	2.1M	16.993M
2437MHz	Pass	500k	2.1M	17.147M	2M	17.039M
2452MHz	Pass	500k	2.05M	17.22M	2.1M	17.03M
802.11ax HEW40_RU52_Index42_40MHz_Nss1,(MCS0)_2TX	-	-	-	-	-	-
2422MHz	Pass	500k	15.05M	17.257M	15.05M	17.121M
2437MHz	Pass	500k	15.05M	17.274M	15.05M	17.127M
2452MHz	Pass	500k	15.05M	17.25M	15M	17.088M
802.11ax HEW40_RU106_Index54_40MHz_Nss1,(MCS0)_2TX	-	-	-	-	-	-
2422MHz	Pass	500k	17.1M	18.082M	17.1M	17.932M
2437MHz	Pass	500k	17.25M	18.952M	17.3M	18.587M
2452MHz	Pass	500k	17.45M	19.073M	17.25M	18.61M





Mode	Result	Limit (Hz)	Port 1-N dB (Hz)	Port 1-OBW (Hz)	Port 2-N dB (Hz)	Port 2-OBW (Hz)
802.11ax HEW40_RU242_Index61_40MHz_Nss1,(MCS0)_2TX	-	-	-	-	-	-
2422MHz	Pass	500k	18.85M	19.359M	18.8M	19.006M
2437MHz	Pass	500k	18.85M	19.384M	18.75M	19.03M
2452MHz	Pass	500k	18.85M	19.356M	18.85M	19.026M

Port X-N dB = Port X 6dB down bandwidth;  
Port X-OBW = Port X 99% occupied bandwidth

2.4-2.4835GHz\_802.11ax HEW20\_RU26\_Index3\_20MHz\_Nss1,(MCS0)\_2TX

EBW

2412MHz

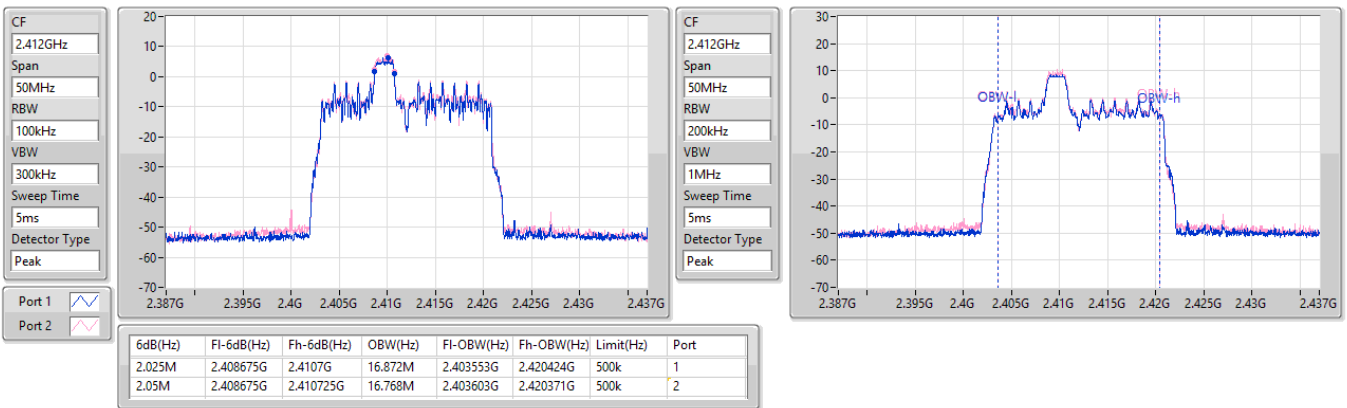

2.4-2.4835GHz\_802.11ax HEW20\_RU26\_Index3\_20MHz\_Nss1,(MCS0)\_2TX

EBW

2437MHz

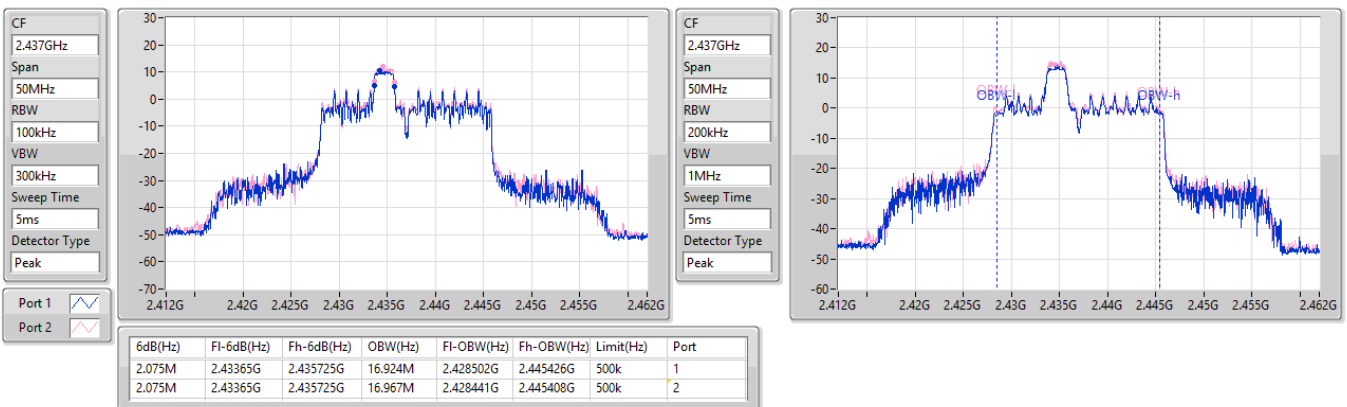

2.4-2.4835GHz\_802.11ax HEW20\_RU26\_Index3\_20MHz\_Nss1,(MCS0)\_2TX

EBW

2462MHz

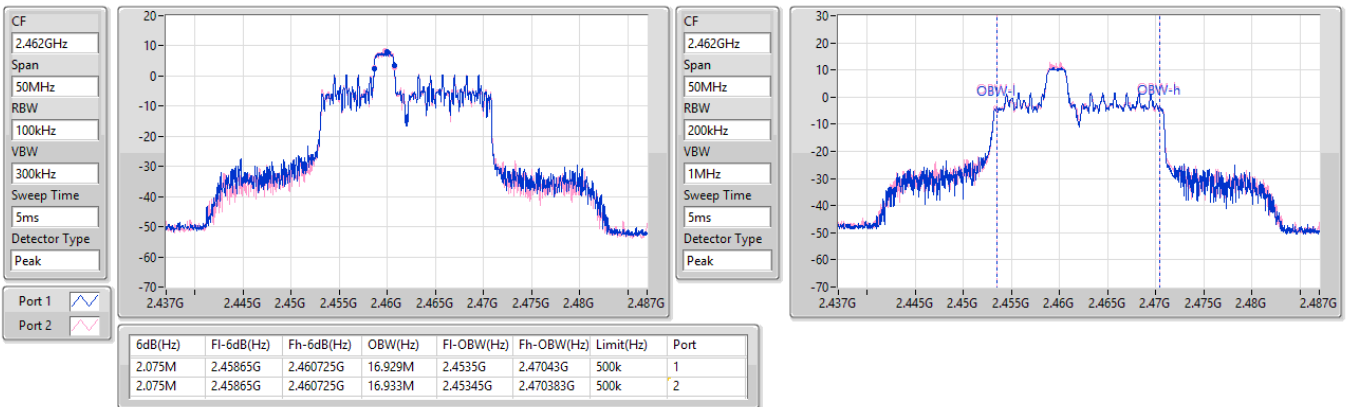

2.4-2.4835GHz\_802.11ax HEW20\_RU52\_Index38\_20MHz\_Nss1,(MCS0)\_2TX

EBW

2412MHz

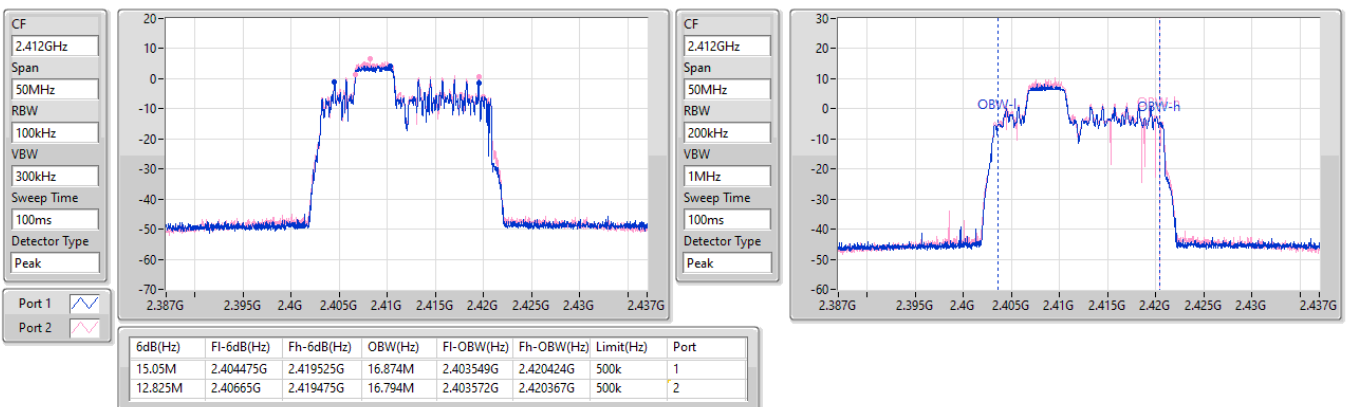



2.4-2.4835GHz\_802.11ax\_HEW20\_RU52\_Index38\_20MHz\_Nss1,(MCS0)\_2TX

EBW

2437MHz

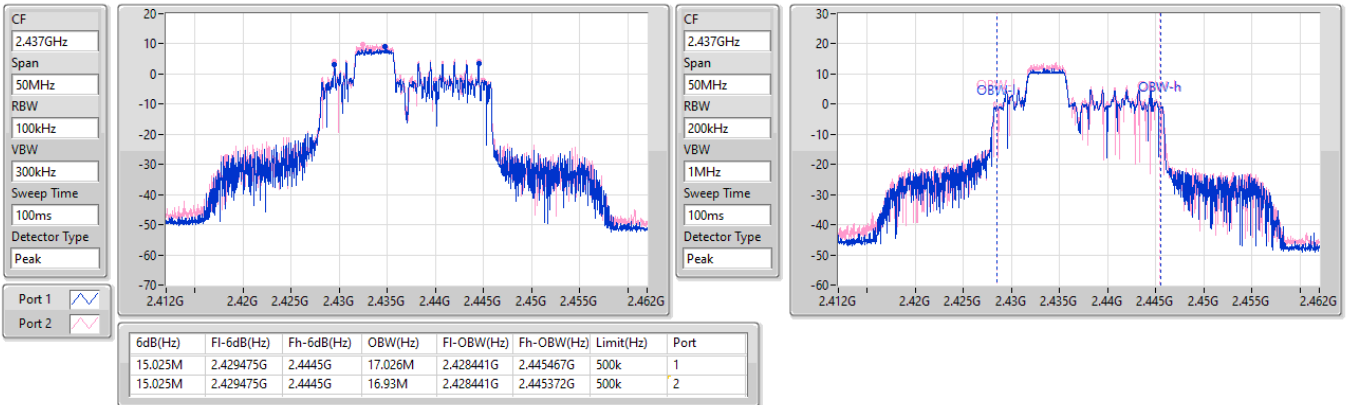

2.4-2.4835GHz\_802.11ax\_HEW20\_RU52\_Index38\_20MHz\_Nss1,(MCS0)\_2TX

EBW

2462MHz

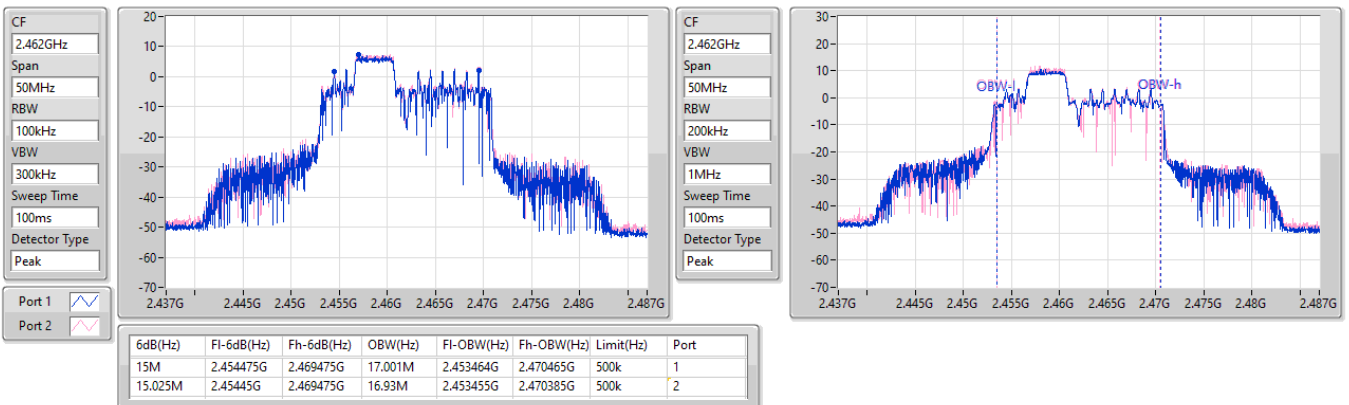

2.4-2.4835GHz\_802.11ax HEW20\_RU106\_Index53\_20MHz\_Nss1,(MCS0)\_2TX

EBW

2412MHz

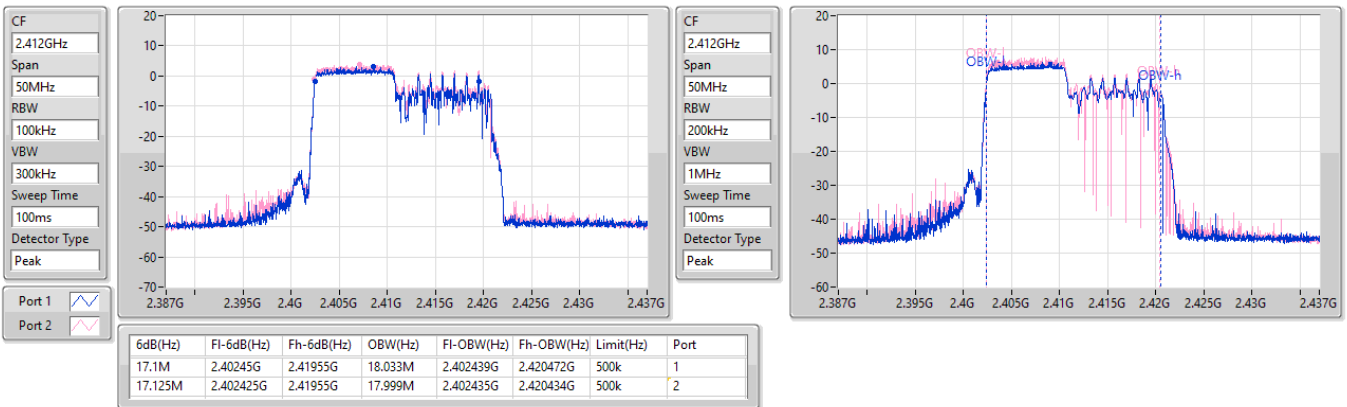

2.4-2.4835GHz\_802.11ax HEW20\_RU106\_Index53\_20MHz\_Nss1,(MCS0)\_2TX

EBW

2437MHz

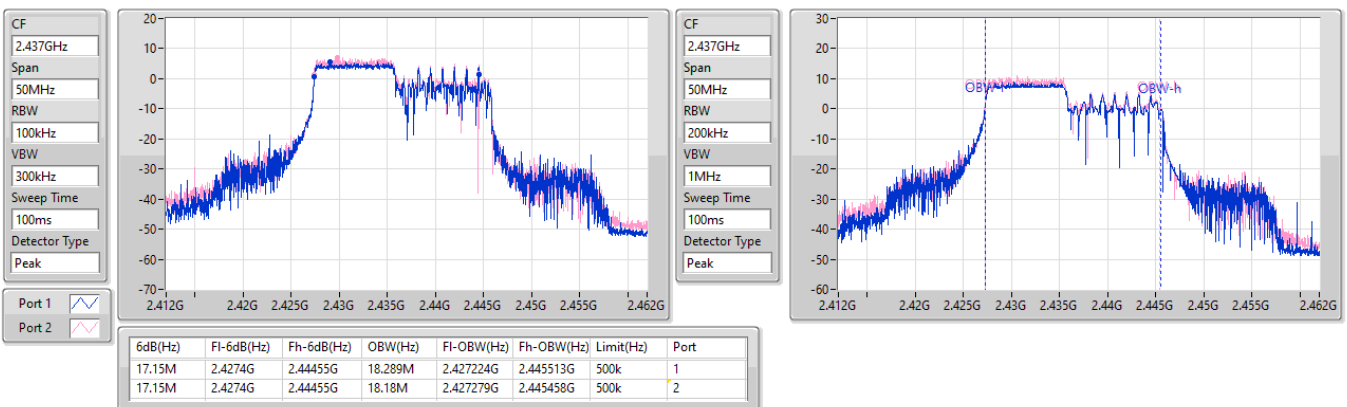



2.4-2.4835GHz\_802.11ax HEW20\_RU106\_Index53\_20MHz\_Nss1,(MCS0)\_2TX

EBW

2462MHz

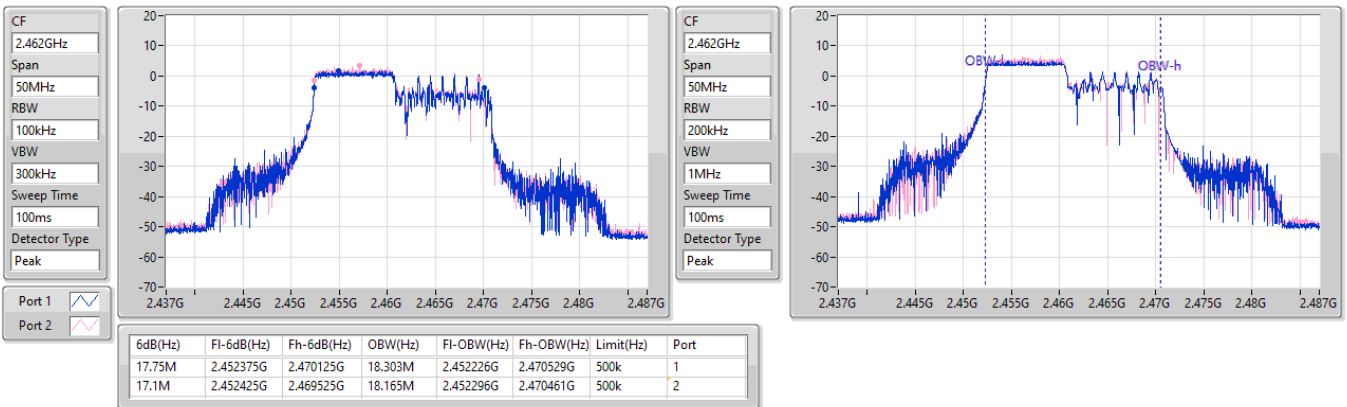

2.4-2.4835GHz\_802.11ax HEW40\_RU26\_Index12\_40MHz\_Nss1,(MCS0)\_2TX

EBW

2422MHz

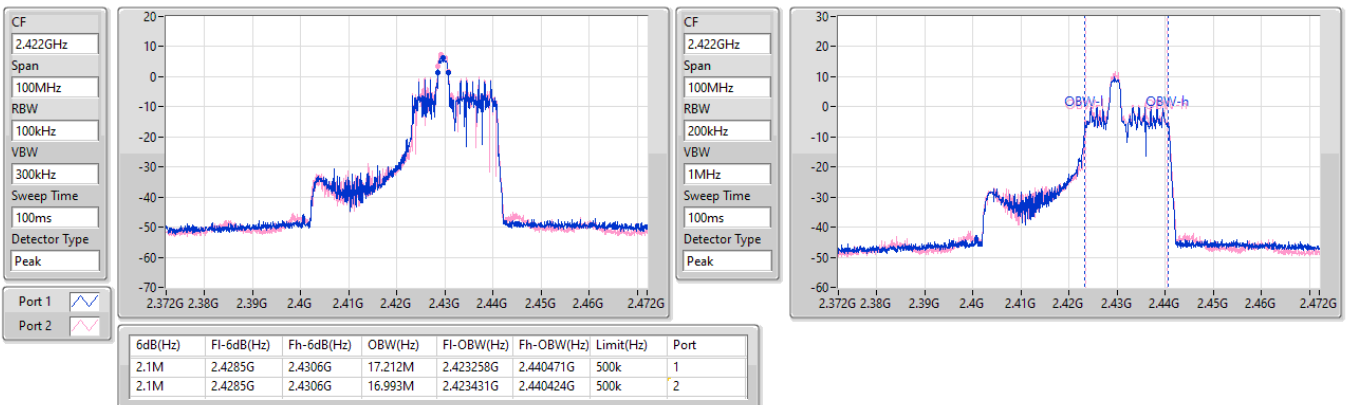



2.4-2.4835GHz\_802.11ax\_HEW40\_RU26\_Index12\_40MHz\_Nss1,(MCS0)\_2TX

EBW

2437MHz

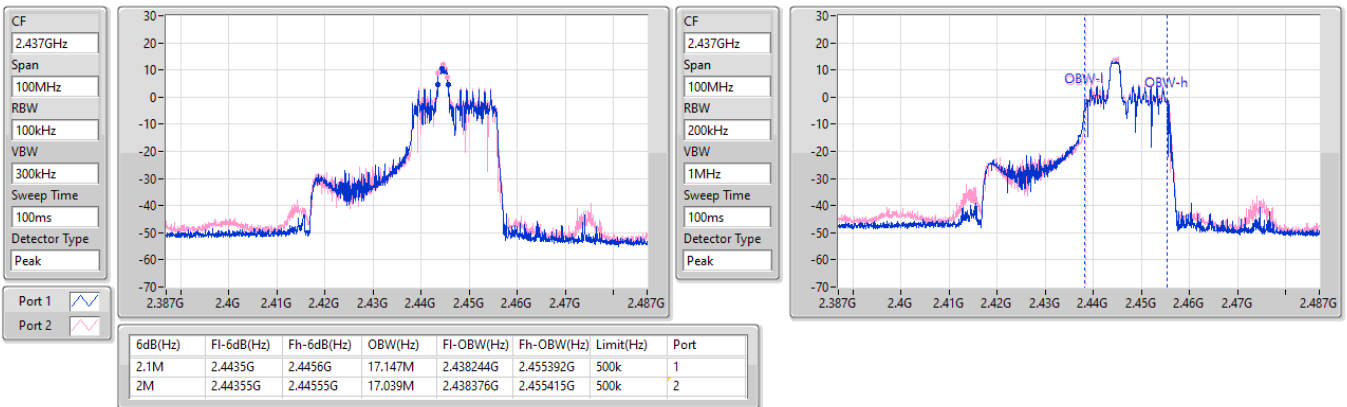

2.4-2.4835GHz\_802.11ax\_HEW40\_RU26\_Index12\_40MHz\_Nss1,(MCS0)\_2TX

EBW

2452MHz

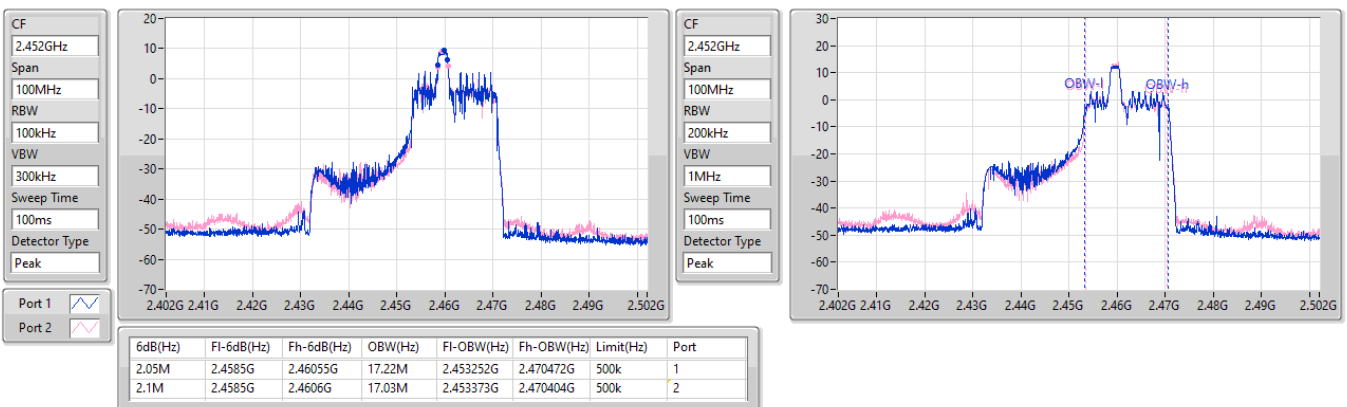



2.4-2.4835GHz\_802.11ax HEW40\_RU52\_Index42\_40MHz\_Nss1,(MCS0)\_2TX

EBW

2422MHz

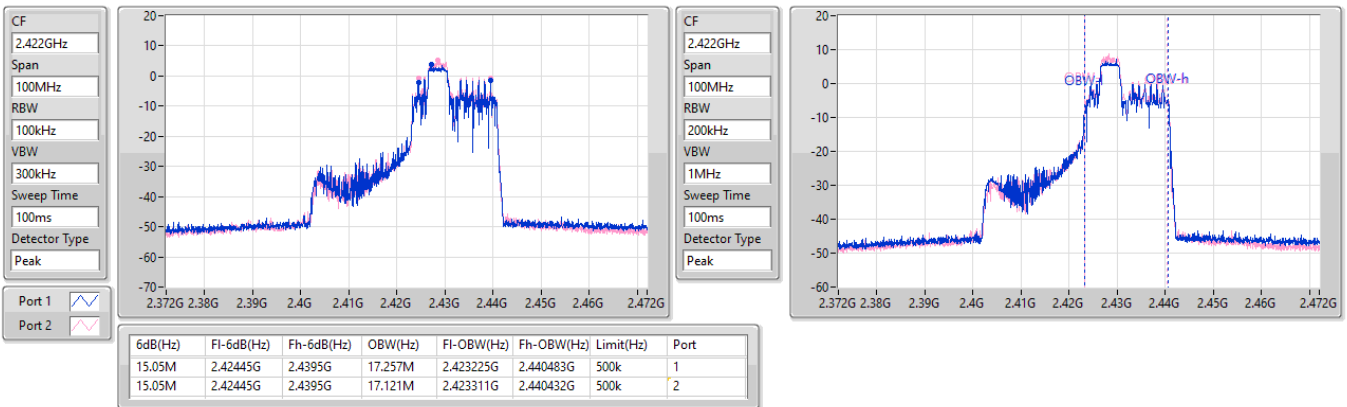

2.4-2.4835GHz\_802.11ax HEW40\_RU52\_Index42\_40MHz\_Nss1,(MCS0)\_2TX

EBW

2437MHz

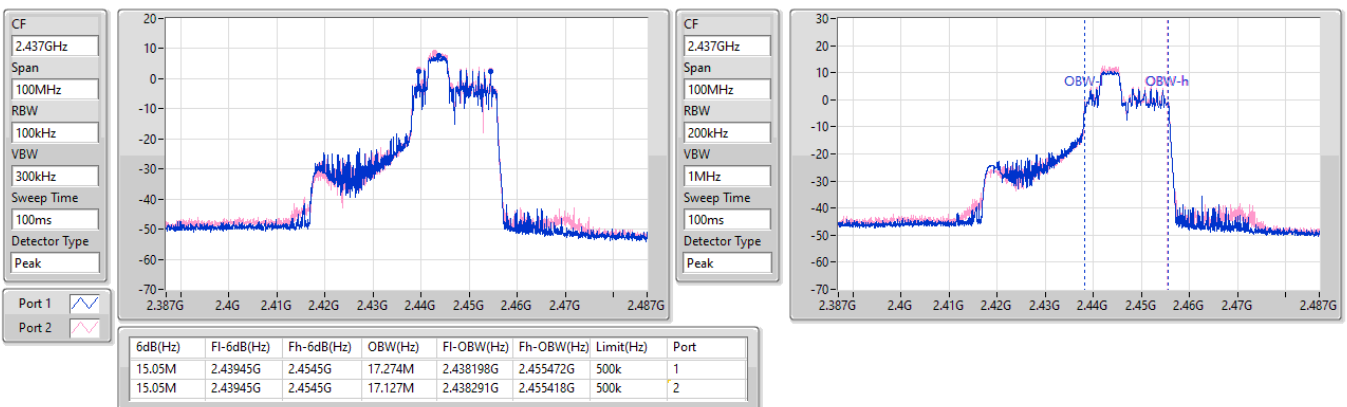





2.4-2.4835GHz\_802.11ax HEW40\_RU52\_Index42\_40MHz\_Nss1,(MCS0)\_2TX

EBW

2452MHz

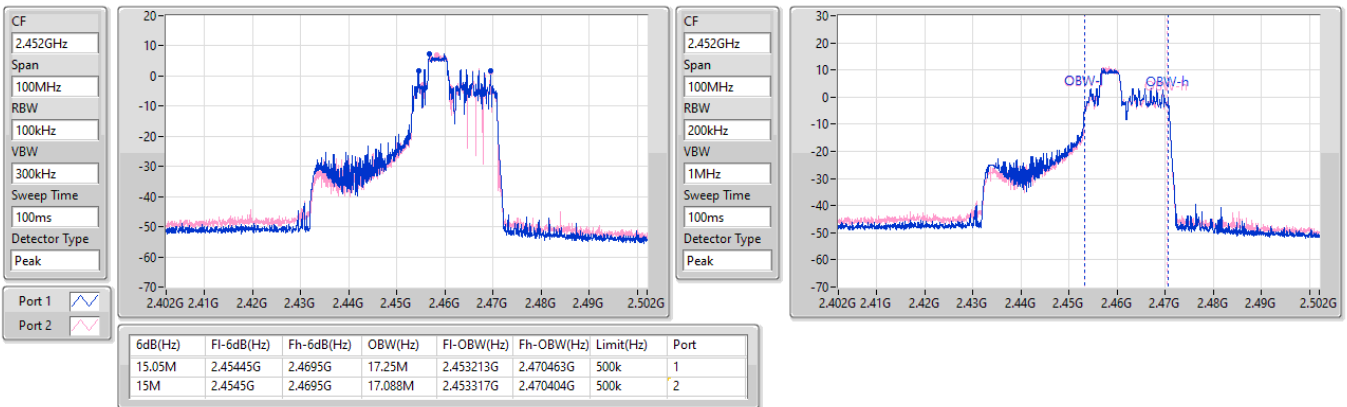

2.4-2.4835GHz\_802.11ax HEW40\_RU106\_Index54\_40MHz\_Nss1,(MCS0)\_2TX

EBW

2422MHz

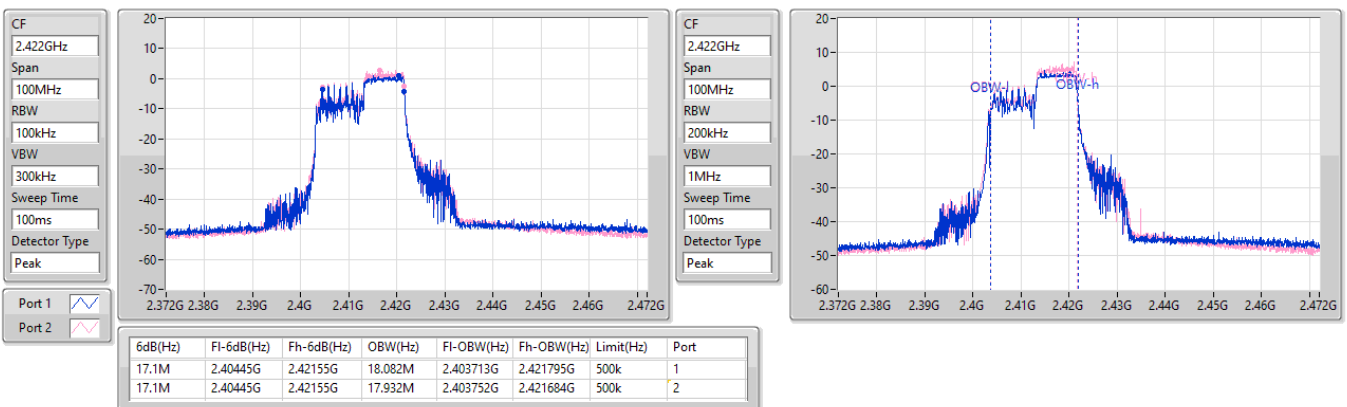

2.4-2.4835GHz\_802.11ax HEW40\_RU106\_Index54\_40MHz\_Nss1,(MCS0)\_2TX

EBW

2437MHz

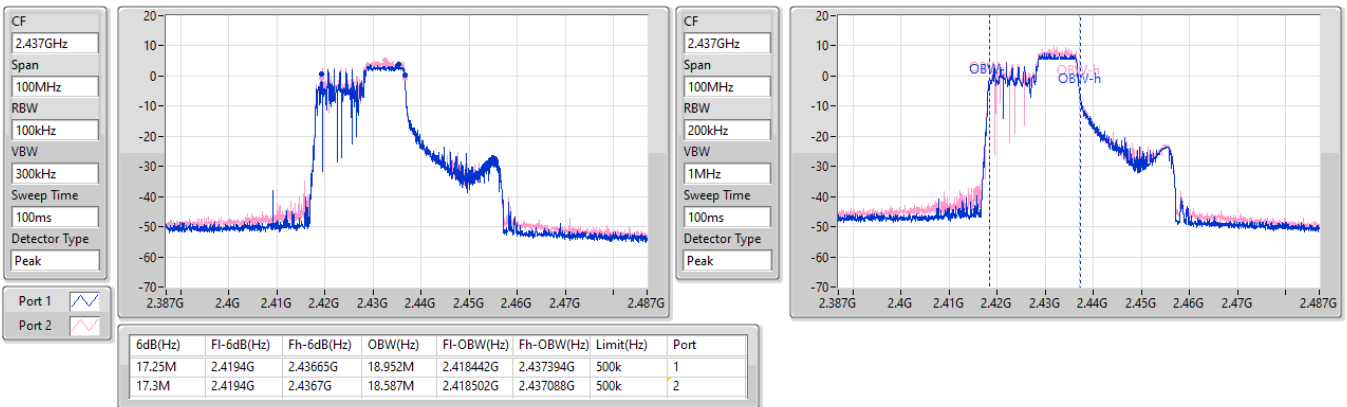

2.4-2.4835GHz\_802.11ax HEW40\_RU106\_Index54\_40MHz\_Nss1,(MCS0)\_2TX

EBW

2452MHz

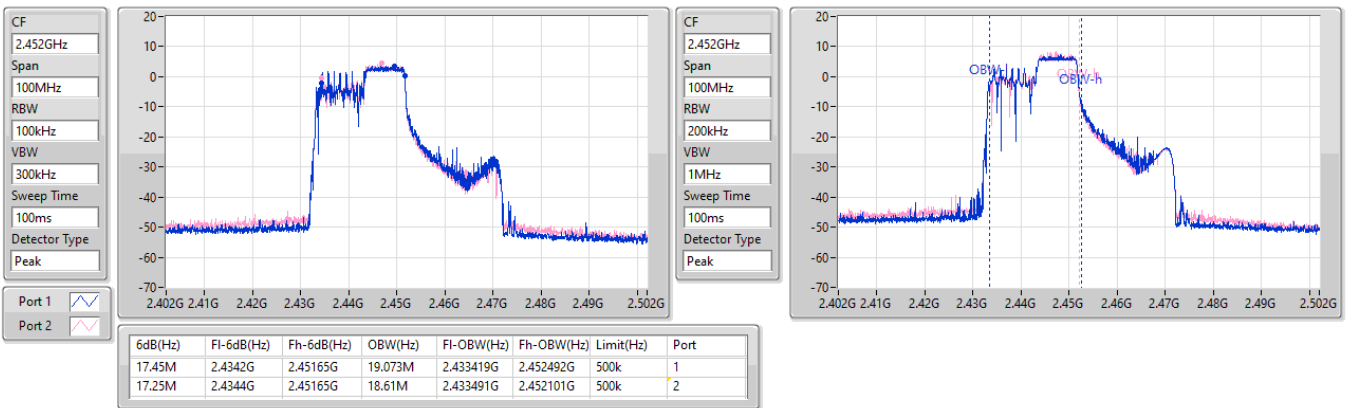

2.4-2.4835GHz\_802.11ax HEW40\_RU242\_Index61\_40MHz\_Nss1,(MCS0)\_2TX

EBW

2422MHz

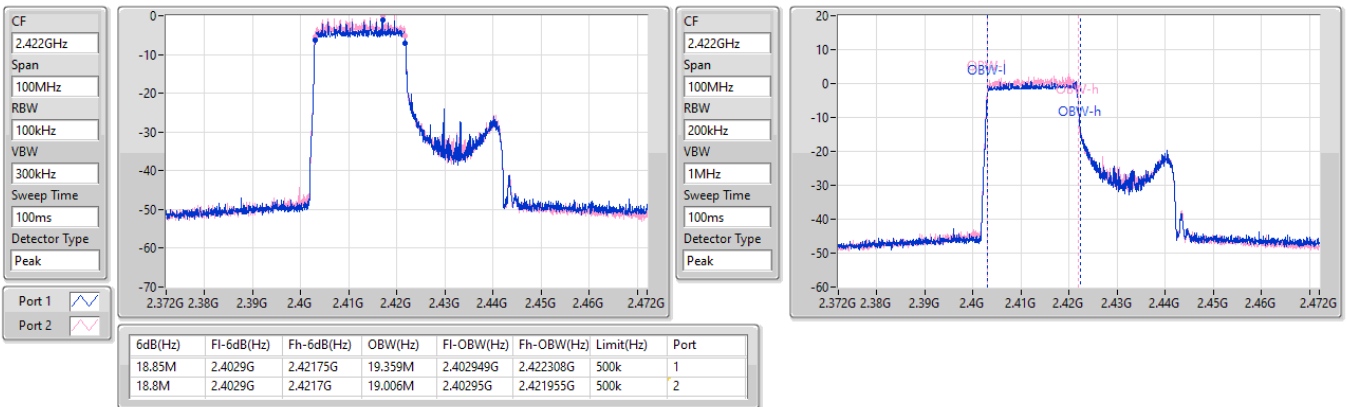

2.4-2.4835GHz\_802.11ax HEW40\_RU242\_Index61\_40MHz\_Nss1,(MCS0)\_2TX

EBW

2437MHz

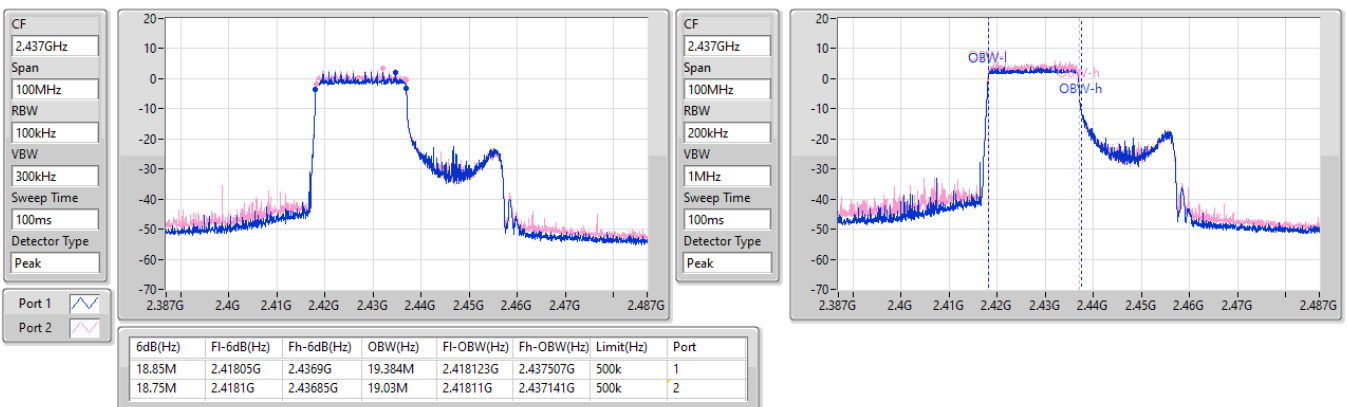



2.4-2.4835GHz\_802.11ax HEW40\_RU242\_Index61\_40MHz\_Nss1,(MCS0)\_2TX

EBW

2452MHz

CF: 2.452GHz  
 Span: 100MHz  
 RBW: 100kHz  
 VBW: 300kHz  
 Sweep Time: 100ms  
 Detector Type: Peak

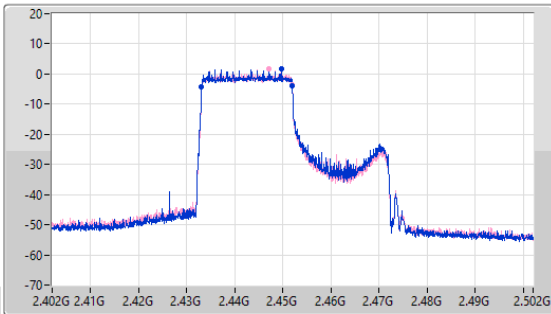

CF: 2.452GHz  
 Span: 100MHz  
 RBW: 200kHz  
 VBW: 1MHz  
 Sweep Time: 100ms  
 Detector Type: Peak

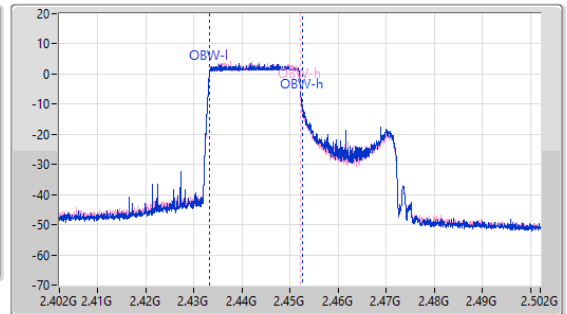

6dB(Hz)	Fl-6dB(Hz)	Fh-6dB(Hz)	OBW(Hz)	Fl-OBW(Hz)	Fh-OBW(Hz)	Limit(Hz)	Port
18.85M	2.43305G	2.4519G	19.356M	2.43312G	2.452476G	500k	1
18.85M	2.43305G	2.4519G	19.026M	2.433123G	2.452149G	500k	2



Non-beamforming mode

Summary

Mode	Total Power (dBm)	Total Power (W)
2.4-2.4835GHz	-	-
802.11ax HEW20_RU26_Index3_20MHz_Nss1,(MCS0)_2TX	27.54	0.56754
802.11ax HEW20_RU52_Index38_20MHz_Nss1,(MCS0)_2TX	28.31	0.67764
802.11ax HEW20_RU106_Index53_20MHz_Nss1,(MCS0)_2TX	27.98	0.62806
802.11ax HEW40_RU26_Index12_40MHz_Nss1,(MCS0)_2TX	27.08	0.51050
802.11ax HEW40_RU52_Index42_40MHz_Nss1,(MCS0)_2TX	26.89	0.48865
802.11ax HEW40_RU106_Index54_40MHz_Nss1,(MCS0)_2TX	26.91	0.49091
802.11ax HEW40_RU242_Index61_40MHz_Nss1,(MCS0)_2TX	26.92	0.49204

Result

Mode	Result	DG (dBi)	Port 1 (dBm)	Port 2 (dBm)	Total Power (dBm)	Power Limit (dBm)	EIRP (dBm)	EIRP Limit (dBm)
802.11ax HEW20_RU26_Index3_20MHz_Nss1,(MCS0)_2TX	-	-	-	-	-	-	-	-
2412MHz	Pass	2.40	19.41	20.74	23.14	30.00	25.54	36.00
2437MHz	Pass	2.40	24.31	24.73	27.54	30.00	29.94	36.00
2462MHz	Pass	2.40	21.67	22.13	24.92	30.00	27.32	36.00
802.11ax HEW20_RU52_Index38_20MHz_Nss1,(MCS0)_2TX	-	-	-	-	-	-	-	-
2412MHz	Pass	2.40	21.02	21.85	24.47	30.00	26.87	36.00
2437MHz	Pass	2.40	25.27	25.33	28.31	30.00	30.71	36.00
2462MHz	Pass	2.40	23.61	23.37	26.50	30.00	28.90	36.00
802.11ax HEW20_RU106_Index53_20MHz_Nss1,(MCS0)_2TX	-	-	-	-	-	-	-	-
2412MHz	Pass	2.40	22.51	23.74	26.18	30.00	28.58	36.00
2437MHz	Pass	2.40	24.97	24.96	27.98	30.00	30.38	36.00
2462MHz	Pass	2.40	21.62	21.85	24.75	30.00	27.15	36.00
802.11ax HEW40_RU26_Index12_40MHz_Nss1,(MCS0)_2TX	-	-	-	-	-	-	-	-
2422MHz	Pass	2.40	19.75	20.74	23.28	30.00	25.68	36.00
2437MHz	Pass	2.40	24.03	24.11	27.08	30.00	29.48	36.00
2452MHz	Pass	2.40	23.46	22.78	26.14	30.00	28.54	36.00
802.11ax HEW40_RU52_Index42_40MHz_Nss1,(MCS0)_2TX	-	-	-	-	-	-	-	-
2422MHz	Pass	2.40	20.22	21.16	23.73	30.00	26.13	36.00
2437MHz	Pass	2.40	23.83	23.92	26.89	30.00	29.29	36.00
2452MHz	Pass	2.40	24.03	23.16	26.63	30.00	29.03	36.00
802.11ax HEW40_RU106_Index54_40MHz_Nss1,(MCS0)_2TX	-	-	-	-	-	-	-	-
2422MHz	Pass	2.40	20.32	21.02	23.69	30.00	26.09	36.00
2437MHz	Pass	2.40	23.89	23.91	26.91	30.00	29.31	36.00
2452MHz	Pass	2.40	23.81	23.15	26.50	30.00	28.90	36.00



## Conducted Output Power(Peak) - SC Module

## Appendix B.1

Mode	Result	DG (dBi)	Port 1 (dBm)	Port 2 (dBm)	Total Power (dBm)	Power Limit (dBm)	EIRP (dBm)	EIRP Limit (dBm)
802.11ax HEW40_RU242_Index61_40MHz_Nss1,(MCS0)_2TX	-	-	-	-	-	-	-	-
2422MHz	Pass	2.40	20.14	20.93	23.56	30.00	25.96	36.00
2437MHz	Pass	2.40	23.7	24.11	26.92	30.00	29.32	36.00
2452MHz	Pass	2.40	23.24	22.59	25.94	30.00	28.34	36.00

DG = Directional Gain; Port X = Port X output power



Non-beamforming mode

Summary

Mode	Total Power (dBm)	Total Power (W)
2.4-2.4835GHz	-	-
802.11ax HEW20_RU26_Index3_20MHz_Nss1,(MCS0)_2TX	18.61	0.07261
802.11ax HEW20_RU52_Index38_20MHz_Nss1,(MCS0)_2TX	19.08	0.08091
802.11ax HEW20_RU106_Index53_20MHz_Nss1,(MCS0)_2TX	18.44	0.06982
802.11ax HEW40_RU26_Index12_40MHz_Nss1,(MCS0)_2TX	18.21	0.06622
802.11ax HEW40_RU52_Index42_40MHz_Nss1,(MCS0)_2TX	17.61	0.05768
802.11ax HEW40_RU106_Index54_40MHz_Nss1,(MCS0)_2TX	17.44	0.05546
802.11ax HEW40_RU242_Index61_40MHz_Nss1,(MCS0)_2TX	17.34	0.05420

Result

Mode	Result	DG (dBi)	Port 1 (dBm)	Port 2 (dBm)	Total Power (dBm)	Power Limit (dBm)	EIRP (dBm)	EIRP Limit (dBm)
802.11ax HEW20_RU26_Index3_20MHz_Nss1,(MCS0)_2TX	-	-	-	-	-	-	-	-
2412MHz	Pass	2.40	10.24	11.01	13.65	-	16.05	-
2437MHz	Pass	2.40	15.19	15.97	18.61	-	21.01	-
2462MHz	Pass	2.40	12.62	12.75	15.70	-	18.10	-
802.11ax HEW20_RU52_Index38_20MHz_Nss1,(MCS0)_2TX	-	-	-	-	-	-	-	-
2412MHz	Pass	2.40	11.69	12.45	15.10	-	17.50	-
2437MHz	Pass	2.40	15.63	16.47	19.08	-	21.48	-
2462MHz	Pass	2.40	14.11	14.12	17.13	-	19.53	-
802.11ax HEW20_RU106_Index53_20MHz_Nss1,(MCS0)_2TX	-	-	-	-	-	-	-	-
2412MHz	Pass	2.40	12.85	13.64	16.27	-	18.67	-
2437MHz	Pass	2.40	15.04	15.78	18.44	-	20.84	-
2462MHz	Pass	2.40	12.07	12.11	15.10	-	17.50	-
802.11ax HEW40_RU26_Index12_40MHz_Nss1,(MCS0)_2TX	-	-	-	-	-	-	-	-
2422MHz	Pass	2.40	10.81	11.66	14.27	-	16.67	-
2437MHz	Pass	2.40	14.74	15.62	18.21	-	20.61	-
2452MHz	Pass	2.40	14.24	14.03	17.15	-	19.55	-
802.11ax HEW40_RU52_Index42_40MHz_Nss1,(MCS0)_2TX	-	-	-	-	-	-	-	-
2422MHz	Pass	2.40	10.75	11.69	14.26	-	16.66	-
2437MHz	Pass	2.40	14.32	14.86	17.61	-	20.01	-
2452MHz	Pass	2.40	14.22	14.01	17.13	-	19.53	-
802.11ax HEW40_RU106_Index54_40MHz_Nss1,(MCS0)_2TX	-	-	-	-	-	-	-	-
2422MHz	Pass	2.40	10.68	11.61	14.18	-	16.58	-
2437MHz	Pass	2.40	14.11	14.73	17.44	-	19.84	-
2452MHz	Pass	2.40	14.05	13.89	16.98	-	19.38	-



## Conducted Output Power(Average) - SC Module

## Appendix B.2

Mode	Result	DG (dBi)	Port 1 (dBm)	Port 2 (dBm)	Total Power (dBm)	Power Limit (dBm)	EIRP (dBm)	EIRP Limit (dBm)
802.11ax HEW40_RU242_Index61_40MHz_Nss1,(MCS0)_2TX	-	-	-	-	-	-	-	-
2422MHz	Pass	2.40	10.44	11.43	13.97	-	16.37	-
2437MHz	Pass	2.40	14.02	14.61	17.34	-	19.74	-
2452MHz	Pass	2.40	13.39	13.26	16.34	-	18.74	-

DG = Directional Gain; Port X = Port X output power

Note : Conducted average output power is for reference





**Beamforming mode**

**Summary**

Mode	Total Power (dBm)	Total Power (W)
2.4-2.4835GHz	-	-
802.11ax HEW20_RU26_Index3,BF_20MHz_Nss1,(MCS0)_2TX	24.53	0.28379
802.11ax HEW20_RU52_Index38,BF_20MHz_Nss1,(MCS0)_2TX	25.30	0.33884
802.11ax HEW20_RU106_Index53,BF_20MHz_Nss1,(MCS0)_2TX	24.97	0.31405
802.11ax HEW40_RU26_Index12,BF_40MHz_Nss1,(MCS0)_2TX	24.07	0.25527
802.11ax HEW40_RU52_Index42,BF_40MHz_Nss1,(MCS0)_2TX	23.88	0.24434
802.11ax HEW40_RU106_Index54,BF_40MHz_Nss1,(MCS0)_2TX	23.90	0.24547
802.11ax HEW40_RU242_Index61,BF_40MHz_Nss1,(MCS0)_2TX	23.91	0.24604

**Result**

Mode	Result	DG (dBi)	Port 1 (dBm)	Port 2 (dBm)	Total Power (dBm)	Power Limit (dBm)	EIRP (dBm)	EIRP Limit (dBm)
802.11ax HEW20_RU26_Index3,BF_20MHz_Nss1,(MCS0)_2TX	-	-	-	-	-	-	-	-
2412MHz	Pass	5.41	16.4	17.73	20.13	30.00	25.54	36.00
2437MHz	Pass	5.41	21.3	21.72	24.53	30.00	29.94	36.00
2462MHz	Pass	5.41	18.66	19.12	21.91	30.00	27.32	36.00
802.11ax HEW20_RU52_Index38,BF_20MHz_Nss1,(MCS0)_2TX	-	-	-	-	-	-	-	-
2412MHz	Pass	5.41	18.01	18.84	21.46	30.00	26.87	36.00
2437MHz	Pass	5.41	22.26	22.32	25.30	30.00	30.71	36.00
2462MHz	Pass	5.41	20.6	20.36	23.49	30.00	28.90	36.00
802.11ax HEW20_RU106_Index53,BF_20MHz_Nss1,(MCS0)_2TX	-	-	-	-	-	-	-	-
2412MHz	Pass	5.41	19.5	20.73	23.17	30.00	28.58	36.00
2437MHz	Pass	5.41	21.96	21.95	24.97	30.00	30.38	36.00
2462MHz	Pass	5.41	18.61	18.84	21.74	30.00	27.15	36.00
802.11ax HEW40_RU26_Index12,BF_40MHz_Nss1,(MCS0)_2TX	-	-	-	-	-	-	-	-
2422MHz	Pass	5.41	16.74	17.73	20.27	30.00	25.68	36.00
2437MHz	Pass	5.41	21.02	21.1	24.07	30.00	29.48	36.00
2452MHz	Pass	5.41	20.45	19.77	23.13	30.00	28.54	36.00
802.11ax HEW40_RU52_Index42,BF_40MHz_Nss1,(MCS0)_2TX	-	-	-	-	-	-	-	-
2422MHz	Pass	5.41	17.21	18.15	20.72	30.00	26.13	36.00
2437MHz	Pass	5.41	20.82	20.91	23.88	30.00	29.29	36.00
2452MHz	Pass	5.41	21.02	20.15	23.62	30.00	29.03	36.00
802.11ax HEW40_RU106_Index54,BF_40MHz_Nss1,(MCS0)_2TX	-	-	-	-	-	-	-	-
2422MHz	Pass	5.41	17.31	18.01	20.68	30.00	26.09	36.00
2437MHz	Pass	5.41	20.88	20.9	23.90	30.00	29.31	36.00
2452MHz	Pass	5.41	20.8	20.14	23.49	30.00	28.90	36.00



## Conducted Output Power(Peak) - SC Module

## Appendix B.3

Mode	Result	DG (dBi)	Port 1 (dBm)	Port 2 (dBm)	Total Power (dBm)	Power Limit (dBm)	EIRP (dBm)	EIRP Limit (dBm)
802.11ax HEW40_RU242_Index61,BF_40MHz_Nss1,(MCS0)_2TX	-	-	-	-	-	-	-	-
2422MHz	Pass	5.41	17.13	17.92	20.55	30.00	25.96	36.00
2437MHz	Pass	5.41	20.69	21.1	23.91	30.00	29.32	36.00
2452MHz	Pass	5.41	20.23	19.58	22.93	30.00	28.34	36.00

DG = Directional Gain; Port X = Port X output power

### Remarks:

Directional gain =  $2.4 + 10 \cdot \log(2/1) = 5.41$  dBi



**Beamforming mode**

**Summary**

Mode	Total Power (dBm)	Total Power (W)
2.4-2.4835GHz	-	-
802.11ax HEW20_RU26_Index3,BF_20MHz_Nss1,(MCS0)_2TX	15.60	0.03631
802.11ax HEW20_RU52_Index38,BF_20MHz_Nss1,(MCS0)_2TX	16.07	0.04046
802.11ax HEW20_RU106_Index53,BF_20MHz_Nss1,(MCS0)_2TX	15.43	0.03491
802.11ax HEW40_RU26_Index12,BF_40MHz_Nss1,(MCS0)_2TX	15.20	0.03311
802.11ax HEW40_RU52_Index42,BF_40MHz_Nss1,(MCS0)_2TX	14.60	0.02884
802.11ax HEW40_RU106_Index54,BF_40MHz_Nss1,(MCS0)_2TX	14.43	0.02773
802.11ax HEW40_RU242_Index61,BF_40MHz_Nss1,(MCS0)_2TX	14.33	0.02710

**Result**

Mode	Result	DG (dBi)	Port 1 (dBm)	Port 2 (dBm)	Total Power (dBm)	Power Limit (dBm)	EIRP (dBm)	EIRP Limit (dBm)
802.11ax HEW20_RU26_Index3,BF_20MHz_Nss1,(MCS0)_2TX	-	-	-	-	-	-	-	-
2412MHz	Pass	5.41	7.23	8	10.64	-	16.05	-
2437MHz	Pass	5.41	12.18	12.96	15.60	-	21.01	-
2462MHz	Pass	5.41	9.61	9.74	12.69	-	18.10	-
802.11ax HEW20_RU52_Index38,BF_20MHz_Nss1,(MCS0)_2TX	-	-	-	-	-	-	-	-
2412MHz	Pass	5.41	8.68	9.44	12.09	-	17.50	-
2437MHz	Pass	5.41	12.62	13.46	16.07	-	21.48	-
2462MHz	Pass	5.41	11.1	11.11	14.12	-	19.53	-
802.11ax HEW20_RU106_Index53,BF_20MHz_Nss1,(MCS0)_2TX	-	-	-	-	-	-	-	-
2412MHz	Pass	5.41	9.84	10.63	13.26	-	18.67	-
2437MHz	Pass	5.41	12.03	12.77	15.43	-	20.84	-
2462MHz	Pass	5.41	9.06	9.1	12.09	-	17.50	-
802.11ax HEW40_RU26_Index12,BF_40MHz_Nss1,(MCS0)_2TX	-	-	-	-	-	-	-	-
2422MHz	Pass	5.41	7.8	8.65	11.26	-	16.67	-
2437MHz	Pass	5.41	11.73	12.61	15.20	-	20.61	-
2452MHz	Pass	5.41	11.23	11.02	14.14	-	19.55	-
802.11ax HEW40_RU52_Index42,BF_40MHz_Nss1,(MCS0)_2TX	-	-	-	-	-	-	-	-
2422MHz	Pass	5.41	7.74	8.68	11.25	-	16.66	-
2437MHz	Pass	5.41	11.31	11.85	14.60	-	20.01	-
2452MHz	Pass	5.41	11.21	11	14.12	-	19.53	-
802.11ax HEW40_RU106_Index54,BF_40MHz_Nss1,(MCS0)_2TX	-	-	-	-	-	-	-	-
2422MHz	Pass	5.41	7.67	8.6	11.17	-	16.58	-
2437MHz	Pass	5.41	11.1	11.72	14.43	-	19.84	-
2452MHz	Pass	5.41	11.04	10.88	13.97	-	19.38	-



## Conducted Output Power(Average) - SC Module

## Appendix B.4

Mode	Result	DG (dBi)	Port 1 (dBm)	Port 2 (dBm)	Total Power (dBm)	Power Limit (dBm)	EIRP (dBm)	EIRP Limit (dBm)
802.11ax HEW40_RU242_Index61,BF_40MHz_Nss1,(MCS0)_2TX	-	-	-	-	-	-	-	-
2422MHz	Pass	5.41	7.43	8.42	10.96	-	16.37	-
2437MHz	Pass	5.41	11.01	11.6	14.33	-	19.74	-
2452MHz	Pass	5.41	10.38	10.25	13.33	-	18.74	-

DG = Directional Gain; Port X = Port X output power

Note : Conducted average output power is for reference

Remarks:

Directional gain =  $2.4 + 10 \cdot \log(2/1) = 5.41$  dBi



Non-beamforming mode

Summary

Mode	Total Power (dBm)	Total Power (W)
2.4-2.4835GHz	-	-
802.11ax HEW20_RU106_Index53_20MHz_Nss1,(MCS0)_2TX	27.91	0.61802
802.11ax HEW20_RU26_Index3_20MHz_Nss1,(MCS0)_2TX	27.46	0.55719
802.11ax HEW20_RU52_Index38_20MHz_Nss1,(MCS0)_2TX	28.43	0.69663
802.11ax HEW40_RU106_Index54_40MHz_Nss1,(MCS0)_2TX	26.44	0.44055
802.11ax HEW40_RU242_Index61_40MHz_Nss1,(MCS0)_2TX	27.12	0.51523
802.11ax HEW40_RU26_Index12_40MHz_Nss1,(MCS0)_2TX	26.88	0.48753
802.11ax HEW40_RU52_Index42_40MHz_Nss1,(MCS0)_2TX	26.89	0.48865

Result

Mode	Result	DG (dBi)	Port 1 (dBm)	Port 2 (dBm)	Total Power (dBm)	Power Limit (dBm)	EIRP (dBm)	EIRP Limit (dBm)
802.11ax HEW20_RU26_Index3_20MHz_Nss1,(MCS0)_2TX	-	-	-	-	-	-	-	-
2412MHz	Pass	2.40	19.52	19.47	22.51	30.00	24.91	36.00
2437MHz	Pass	2.40	24.35	24.54	27.46	30.00	29.86	36.00
2462MHz	Pass	2.40	21.06	20.88	23.98	30.00	26.38	36.00
802.11ax HEW20_RU52_Index38_20MHz_Nss1,(MCS0)_2TX	-	-	-	-	-	-	-	-
2412MHz	Pass	2.40	20.88	21.21	24.06	30.00	26.46	36.00
2437MHz	Pass	2.40	25.14	25.69	28.43	30.00	30.83	36.00
2462MHz	Pass	2.40	23.24	22.96	26.11	30.00	28.51	36.00
802.11ax HEW20_RU106_Index53_20MHz_Nss1,(MCS0)_2TX	-	-	-	-	-	-	-	-
2412MHz	Pass	2.40	22.31	22.51	25.42	30.00	27.82	36.00
2437MHz	Pass	2.40	24.88	24.91	27.91	30.00	30.31	36.00
2462MHz	Pass	2.40	21.37	21.21	24.30	30.00	26.70	36.00
802.11ax HEW40_RU26_Index12_40MHz_Nss1,(MCS0)_2TX	-	-	-	-	-	-	-	-
2422MHz	Pass	2.40	19.62	19.92	22.78	30.00	25.18	36.00
2437MHz	Pass	2.40	23.82	23.91	26.88	30.00	29.28	36.00
2452MHz	Pass	2.40	22.45	22.52	25.50	30.00	27.90	36.00
802.11ax HEW40_RU52_Index42_40MHz_Nss1,(MCS0)_2TX	-	-	-	-	-	-	-	-
2422MHz	Pass	2.40	20.19	20.22	23.22	30.00	25.62	36.00
2437MHz	Pass	2.40	23.87	23.89	26.89	30.00	29.29	36.00
2452MHz	Pass	2.40	22.98	23.11	26.06	30.00	28.46	36.00
802.11ax HEW40_RU106_Index54_40MHz_Nss1,(MCS0)_2TX	-	-	-	-	-	-	-	-
2422MHz	Pass	2.40	20.51	20.68	23.61	30.00	26.01	36.00
2437MHz	Pass	2.40	23.38	23.48	26.44	30.00	28.84	36.00
2452MHz	Pass	2.40	23.03	23.15	26.10	30.00	28.50	36.00



## Conducted Output Power(Peak) - ST Module

## Appendix B.5

Mode	Result	DG (dBi)	Port 1 (dBm)	Port 2 (dBm)	Total Power (dBm)	Power Limit (dBm)	EIRP (dBm)	EIRP Limit (dBm)
802.11ax HEW40_RU242_Index61_40MHz_Nss1,(MCS0)_2TX	-	-	-	-	-	-	-	-
2422MHz	Pass	2.40	20.15	20.35	23.26	30.00	25.66	36.00
2437MHz	Pass	2.40	23.81	24.39	27.12	30.00	29.52	36.00
2452MHz	Pass	2.40	22.43	22.45	25.45	30.00	27.85	36.00

DG = Directional Gain; Port X = Port X output power



Non-beamforming mode

Summary

Mode	Total Power (dBm)	Total Power (W)
2.4-2.4835GHz	-	-
802.11ax HEW20_RU106_Index53_20MHz_Nss1,(MCS0)_2TX	18.38	0.06887
802.11ax HEW20_RU26_Index3_20MHz_Nss1,(MCS0)_2TX	18.49	0.07063
802.11ax HEW20_RU52_Index38_20MHz_Nss1,(MCS0)_2TX	18.96	0.07870
802.11ax HEW40_RU106_Index54_40MHz_Nss1,(MCS0)_2TX	17.06	0.05082
802.11ax HEW40_RU242_Index61_40MHz_Nss1,(MCS0)_2TX	17.33	0.05408
802.11ax HEW40_RU26_Index12_40MHz_Nss1,(MCS0)_2TX	18.14	0.06516
802.11ax HEW40_RU52_Index42_40MHz_Nss1,(MCS0)_2TX	17.58	0.05728

Result

Mode	Result	DG (dBi)	Port 1 (dBm)	Port 2 (dBm)	Total Power (dBm)	Power Limit (dBm)	EIRP (dBm)	EIRP Limit (dBm)
802.11ax HEW20_RU26_Index3_20MHz_Nss1,(MCS0)_2TX	-	-	-	-	-	-	-	-
2412MHz	Pass	2.40	10.48	10.45	13.48	-	15.88	-
2437MHz	Pass	2.40	15.33	15.62	18.49	-	20.89	-
2462MHz	Pass	2.40	12.57	12.38	15.49	-	17.89	-
802.11ax HEW20_RU52_Index38_20MHz_Nss1,(MCS0)_2TX	-	-	-	-	-	-	-	-
2412MHz	Pass	2.40	11.78	12.05	14.93	-	17.33	-
2437MHz	Pass	2.40	15.78	16.11	18.96	-	21.36	-
2462MHz	Pass	2.40	13.98	13.82	16.91	-	19.31	-
802.11ax HEW20_RU106_Index53_20MHz_Nss1,(MCS0)_2TX	-	-	-	-	-	-	-	-
2412MHz	Pass	2.40	13.01	13.11	16.07	-	18.47	-
2437MHz	Pass	2.40	15.24	15.49	18.38	-	20.78	-
2462MHz	Pass	2.40	12.02	11.79	14.92	-	17.32	-
802.11ax HEW40_RU26_Index12_40MHz_Nss1,(MCS0)_2TX	-	-	-	-	-	-	-	-
2422MHz	Pass	2.40	10.97	11.15	14.07	-	16.47	-
2437MHz	Pass	2.40	14.98	15.27	18.14	-	20.54	-
2452MHz	Pass	2.40	13.84	13.91	16.89	-	19.29	-
802.11ax HEW40_RU52_Index42_40MHz_Nss1,(MCS0)_2TX	-	-	-	-	-	-	-	-
2422MHz	Pass	2.40	10.98	11.19	14.10	-	16.50	-
2437MHz	Pass	2.40	14.42	14.71	17.58	-	19.98	-
2452MHz	Pass	2.40	13.81	13.85	16.84	-	19.24	-
802.11ax HEW40_RU106_Index54_40MHz_Nss1,(MCS0)_2TX	-	-	-	-	-	-	-	-
2422MHz	Pass	2.40	10.98	11.13	14.07	-	16.47	-
2437MHz	Pass	2.40	13.85	14.24	17.06	-	19.46	-
2452MHz	Pass	2.40	13.72	13.82	16.78	-	19.18	-



## Conducted Output Power(Average) - ST Module

## Appendix B.6

Mode	Result	DG (dBi)	Port 1 (dBm)	Port 2 (dBm)	Total Power (dBm)	Power Limit (dBm)	EIRP (dBm)	EIRP Limit (dBm)
802.11ax HEW40_RU242_Index61_40MHz_Nss1,(MCS0)_2TX	-	-	-	-	-	-	-	-
2422MHz	Pass	2.40	10.72	10.95	13.85	-	16.25	-
2437MHz	Pass	2.40	14.13	14.5	17.33	-	19.73	-
2452MHz	Pass	2.40	13.02	13.13	16.09	-	18.49	-

DG = Directional Gain; Port X = Port X output power

Note : Conducted average output power is for reference





**Beamforming mode**

**Summary**

Mode	Total Power (dBm)	Total Power (W)
2.4-2.4835GHz	-	-
802.11ax HEW20_RU106_Index53,BF_20MHz_Nss1,(MCS0)_2TX	24.90	0.30903
802.11ax HEW20_RU26_Index3,BF_20MHz_Nss1,(MCS0)_2TX	24.45	0.27861
802.11ax HEW20_RU52_Index38,BF_20MHz_Nss1,(MCS0)_2TX	25.42	0.34834
802.11ax HEW40_RU106_Index54,BF_40MHz_Nss1,(MCS0)_2TX	23.43	0.22029
802.11ax HEW40_RU242_Index61,BF_40MHz_Nss1,(MCS0)_2TX	24.11	0.25763
802.11ax HEW40_RU26_Index12,BF_40MHz_Nss1,(MCS0)_2TX	23.87	0.24378
802.11ax HEW40_RU52_Index42,BF_40MHz_Nss1,(MCS0)_2TX	23.88	0.24434

**Result**

Mode	Result	DG (dBi)	Port 1 (dBm)	Port 2 (dBm)	Total Power (dBm)	Power Limit (dBm)	EIRP (dBm)	EIRP Limit (dBm)
802.11ax HEW20_RU26_Index3,BF_20MHz_Nss1,(MCS0)_2TX	-	-	-	-	-	-	-	-
2412MHz	Pass	5.41	16.51	16.46	19.50	30.00	24.91	36.00
2437MHz	Pass	5.41	21.34	21.53	24.45	30.00	29.86	36.00
2462MHz	Pass	5.41	18.05	17.87	20.97	30.00	26.38	36.00
802.11ax HEW20_RU52_Index38,BF_20MHz_Nss1,(MCS0)_2TX	-	-	-	-	-	-	-	-
2412MHz	Pass	5.41	17.87	18.2	21.05	30.00	26.46	36.00
2437MHz	Pass	5.41	22.13	22.68	25.42	30.00	30.83	36.00
2462MHz	Pass	5.41	20.23	19.95	23.10	30.00	28.51	36.00
802.11ax HEW20_RU106_Index53,BF_20MHz_Nss1,(MCS0)_2TX	-	-	-	-	-	-	-	-
2412MHz	Pass	5.41	19.3	19.5	22.41	30.00	27.82	36.00
2437MHz	Pass	5.41	21.87	21.9	24.90	30.00	30.31	36.00
2462MHz	Pass	5.41	18.36	18.2	21.29	30.00	26.70	36.00
802.11ax HEW40_RU26_Index12,BF_40MHz_Nss1,(MCS0)_2TX	-	-	-	-	-	-	-	-
2422MHz	Pass	5.41	16.61	16.91	19.77	30.00	25.18	36.00
2437MHz	Pass	5.41	20.81	20.9	23.87	30.00	29.28	36.00
2452MHz	Pass	5.41	19.44	19.51	22.49	30.00	27.90	36.00
802.11ax HEW40_RU52_Index42,BF_40MHz_Nss1,(MCS0)_2TX	-	-	-	-	-	-	-	-
2422MHz	Pass	5.41	17.18	17.21	20.21	30.00	25.62	36.00
2437MHz	Pass	5.41	20.86	20.88	23.88	30.00	29.29	36.00
2452MHz	Pass	5.41	19.97	20.1	23.05	30.00	28.46	36.00
802.11ax HEW40_RU106_Index54,BF_40MHz_Nss1,(MCS0)_2TX	-	-	-	-	-	-	-	-
2422MHz	Pass	5.41	17.5	17.67	20.60	30.00	26.01	36.00
2437MHz	Pass	5.41	20.37	20.47	23.43	30.00	28.84	36.00
2452MHz	Pass	5.41	20.02	20.14	23.09	30.00	28.50	36.00



## Conducted Output Power(Peak) - ST Module

## Appendix B.7

Mode	Result	DG (dBi)	Port 1 (dBm)	Port 2 (dBm)	Total Power (dBm)	Power Limit (dBm)	EIRP (dBm)	EIRP Limit (dBm)
802.11ax HEW40_RU242_Index61,BF_40MHz_Nss1,(MCS0)_2TX	-	-	-	-	-	-	-	-
2422MHz	Pass	5.41	17.14	17.34	20.25	30.00	25.66	36.00
2437MHz	Pass	5.41	20.8	21.38	24.11	30.00	29.52	36.00
2452MHz	Pass	5.41	19.42	19.44	22.44	30.00	27.85	36.00

DG = Directional Gain; Port X = Port X output power

### Remarks:

Directional gain =  $2.4 + 10 \cdot \log(2/1) = 5.41$  dBi



**Beamforming mode**

**Summary**

Mode	Total Power (dBm)	Total Power (W)
2.4-2.4835GHz	-	-
802.11ax HEW20_RU106_Index53,BF_20MHz_Nss1,(MCS0)_2TX	15.37	0.03443
802.11ax HEW20_RU26_Index3,BF_20MHz_Nss1,(MCS0)_2TX	15.48	0.03532
802.11ax HEW20_RU52_Index38,BF_20MHz_Nss1,(MCS0)_2TX	15.95	0.03936
802.11ax HEW40_RU106_Index54,BF_40MHz_Nss1,(MCS0)_2TX	14.05	0.02541
802.11ax HEW40_RU242_Index61,BF_40MHz_Nss1,(MCS0)_2TX	14.32	0.02704
802.11ax HEW40_RU26_Index12,BF_40MHz_Nss1,(MCS0)_2TX	15.13	0.03258
802.11ax HEW40_RU52_Index42,BF_40MHz_Nss1,(MCS0)_2TX	14.57	0.02864

**Result**

Mode	Result	DG (dBi)	Port 1 (dBm)	Port 2 (dBm)	Total Power (dBm)	Power Limit (dBm)	EIRP (dBm)	EIRP Limit (dBm)
802.11ax HEW20_RU26_Index3,BF_20MHz_Nss1,(MCS0)_2TX	-	-	-	-	-	-	-	-
2412MHz	Pass	5.41	7.47	7.44	10.47	-	15.88	-
2437MHz	Pass	5.41	12.32	12.61	15.48	-	20.89	-
2462MHz	Pass	5.41	9.56	9.37	12.48	-	17.89	-
802.11ax HEW20_RU52_Index38,BF_20MHz_Nss1,(MCS0)_2TX	-	-	-	-	-	-	-	-
2412MHz	Pass	5.41	8.77	9.04	11.92	-	17.33	-
2437MHz	Pass	5.41	12.77	13.1	15.95	-	21.36	-
2462MHz	Pass	5.41	10.97	10.81	13.90	-	19.31	-
802.11ax HEW20_RU106_Index53,BF_20MHz_Nss1,(MCS0)_2TX	-	-	-	-	-	-	-	-
2412MHz	Pass	5.41	10	10.1	13.06	-	18.47	-
2437MHz	Pass	5.41	12.23	12.48	15.37	-	20.78	-
2462MHz	Pass	5.41	9.01	8.78	11.91	-	17.32	-
802.11ax HEW40_RU26_Index12,BF_40MHz_Nss1,(MCS0)_2TX	-	-	-	-	-	-	-	-
2422MHz	Pass	5.41	7.96	8.14	11.06	-	16.47	-
2437MHz	Pass	5.41	11.97	12.26	15.13	-	20.54	-
2452MHz	Pass	5.41	10.83	10.9	13.88	-	19.29	-
802.11ax HEW40_RU52_Index42,BF_40MHz_Nss1,(MCS0)_2TX	-	-	-	-	-	-	-	-
2422MHz	Pass	5.41	7.97	8.18	11.09	-	16.50	-
2437MHz	Pass	5.41	11.41	11.7	14.57	-	19.98	-
2452MHz	Pass	5.41	10.8	10.84	13.83	-	19.24	-
802.11ax HEW40_RU106_Index54,BF_40MHz_Nss1,(MCS0)_2TX	-	-	-	-	-	-	-	-
2422MHz	Pass	5.41	7.97	8.12	11.06	-	16.47	-
2437MHz	Pass	5.41	10.84	11.23	14.05	-	19.46	-
2452MHz	Pass	5.41	10.71	10.81	13.77	-	19.18	-



## Conducted Output Power(Average) - ST Module

## Appendix B.8

Mode	Result	DG (dBi)	Port 1 (dBm)	Port 2 (dBm)	Total Power (dBm)	Power Limit (dBm)	EIRP (dBm)	EIRP Limit (dBm)
802.11ax HEW40_RU242_Index61,BF_40MHz_Nss1,(MCS0)_2TX	-	-	-	-	-	-	-	-
2422MHz	Pass	5.41	7.71	7.94	10.84	-	16.25	-
2437MHz	Pass	5.41	11.12	11.49	14.32	-	19.73	-
2452MHz	Pass	5.41	10.01	10.12	13.08	-	18.49	-

DG = Directional Gain; Port X = Port X output power

Note : Conducted average output power is for reference

Remarks:

Directional gain =  $2.4 + 10 \cdot \log(2/1) = 5.41$  dBi



Summary

Mode	PD (dBm/RBW)
2.4-2.4835GHz	-
802.11ax HEW20_RU26_Index3_20MHz_Nss1,(MCS0)_2TX	2.25
802.11ax HEW20_RU52_Index38_20MHz_Nss1,(MCS0)_2TX	-0.04
802.11ax HEW20_RU106_Index53_20MHz_Nss1,(MCS0)_2TX	-3.84
802.11ax HEW40_RU26_Index12_40MHz_Nss1,(MCS0)_2TX	1.35
802.11ax HEW40_RU52_Index42_40MHz_Nss1,(MCS0)_2TX	-1.15
802.11ax HEW40_RU106_Index54_40MHz_Nss1,(MCS0)_2TX	-5.13
802.11ax HEW40_RU242_Index61_40MHz_Nss1,(MCS0)_2TX	-8.79

RBW = 3kHz;



Result

Mode	Result	DG (dBi)	Port 1 (dBm/RBW)	Port 2 (dBm/RBW)	PD (dBm/RBW)	PD Limit (dBm/RBW)
802.11ax HEW20_RU26_Index3_20MHz_Nss1,(MCS0)_2TX	-	-	-	-	-	-
2412MHz	Pass	5.41	-6.54	-3.83	-2.91	8.00
2437MHz	Pass	5.41	-2.30	0.84	2.25	8.00
2462MHz	Pass	5.41	-4.18	-4.02	-1.25	8.00
802.11ax HEW20_RU52_Index38_20MHz_Nss1,(MCS0)_2TX	-	-	-	-	-	-
2412MHz	Pass	5.41	-7.69	-6.56	-4.41	8.00
2437MHz	Pass	5.41	-3.85	-1.63	-0.04	8.00
2462MHz	Pass	5.41	-4.71	-5.22	-2.10	8.00
802.11ax HEW20_RU106_Index53_20MHz_Nss1,(MCS0)_2TX	-	-	-	-	-	-
2412MHz	Pass	5.41	-8.76	-8.32	-6.25	8.00
2437MHz	Pass	5.41	-6.84	-5.08	-3.84	8.00
2462MHz	Pass	5.41	-10.75	-8.51	-7.37	8.00
802.11ax HEW40_RU26_Index12_40MHz_Nss1,(MCS0)_2TX	-	-	-	-	-	-
2422MHz	Pass	5.41	-5.00	-4.88	-3.10	8.00
2437MHz	Pass	5.41	-1.25	-0.60	1.24	8.00
2452MHz	Pass	5.41	-2.77	-0.77	1.35	8.00
802.11ax HEW40_RU52_Index42_40MHz_Nss1,(MCS0)_2TX	-	-	-	-	-	-
2422MHz	Pass	5.41	-8.95	-8.02	-6.41	8.00
2437MHz	Pass	5.41	-4.62	-3.22	-1.15	8.00
2452MHz	Pass	5.41	-4.42	-6.09	-2.77	8.00
802.11ax HEW40_RU106_Index54_40MHz_Nss1,(MCS0)_2TX	-	-	-	-	-	-
2422MHz	Pass	5.41	-9.74	-9.35	-7.31	8.00
2437MHz	Pass	5.41	-7.75	-7.37	-5.13	8.00
2452MHz	Pass	5.41	-8.42	-8.13	-5.63	8.00
802.11ax HEW40_RU242_Index61_40MHz_Nss1,(MCS0)_2TX	-	-	-	-	-	-
2422MHz	Pass	5.41	-14.85	-13.05	-11.81	8.00
2437MHz	Pass	5.41	-11.50	-10.84	-8.79	8.00
2452MHz	Pass	5.41	-12.52	-11.92	-9.99	8.00

DG = Directional Gain; RBW = 3kHz;

PD = trace bin-by-bin of each transmits port summing can be performed maximum power density; Port X = Port X Power Density;

Remarks:

Directional gain =  $2.4 + 10 \cdot \log(2/1) = 5.41$  dBi

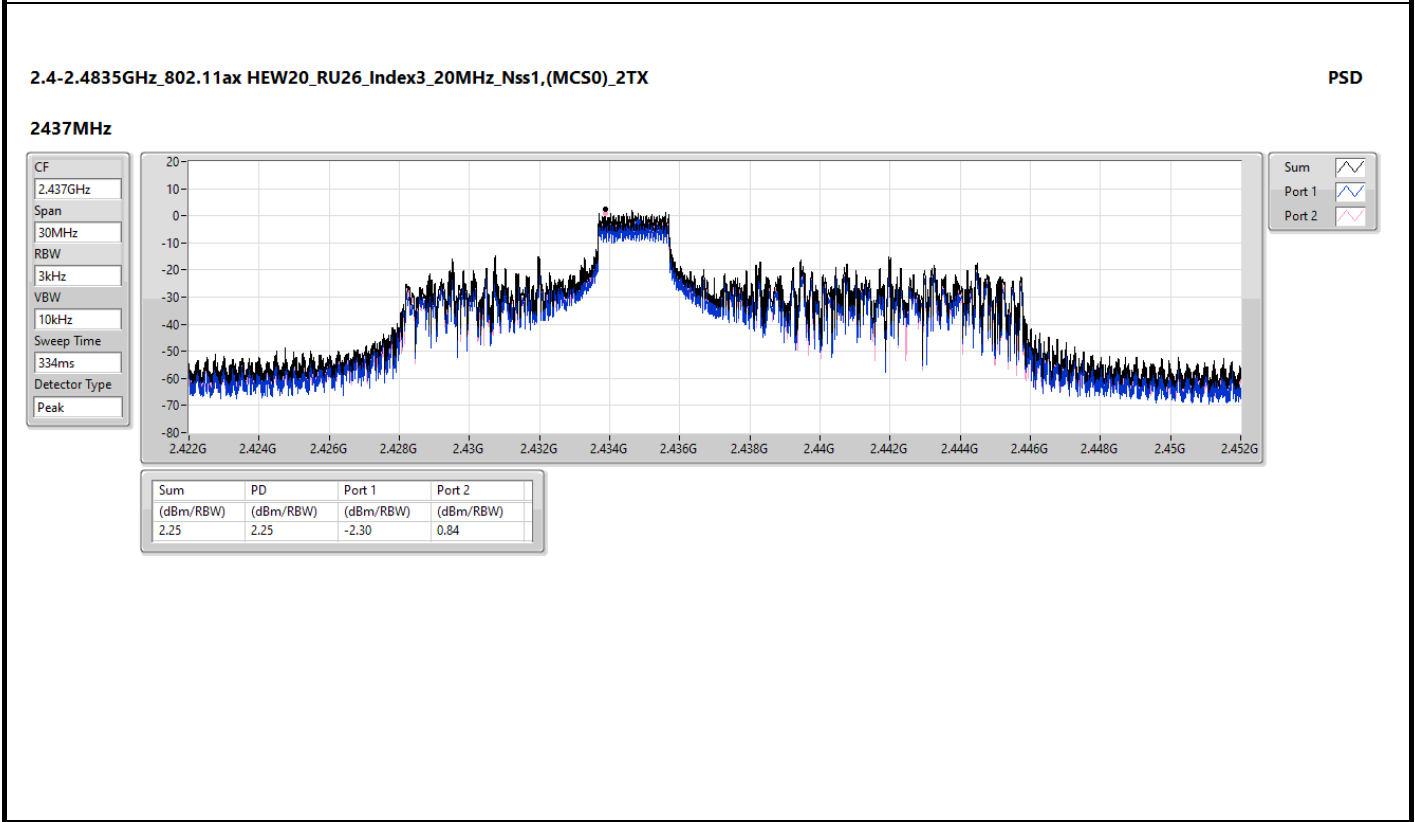
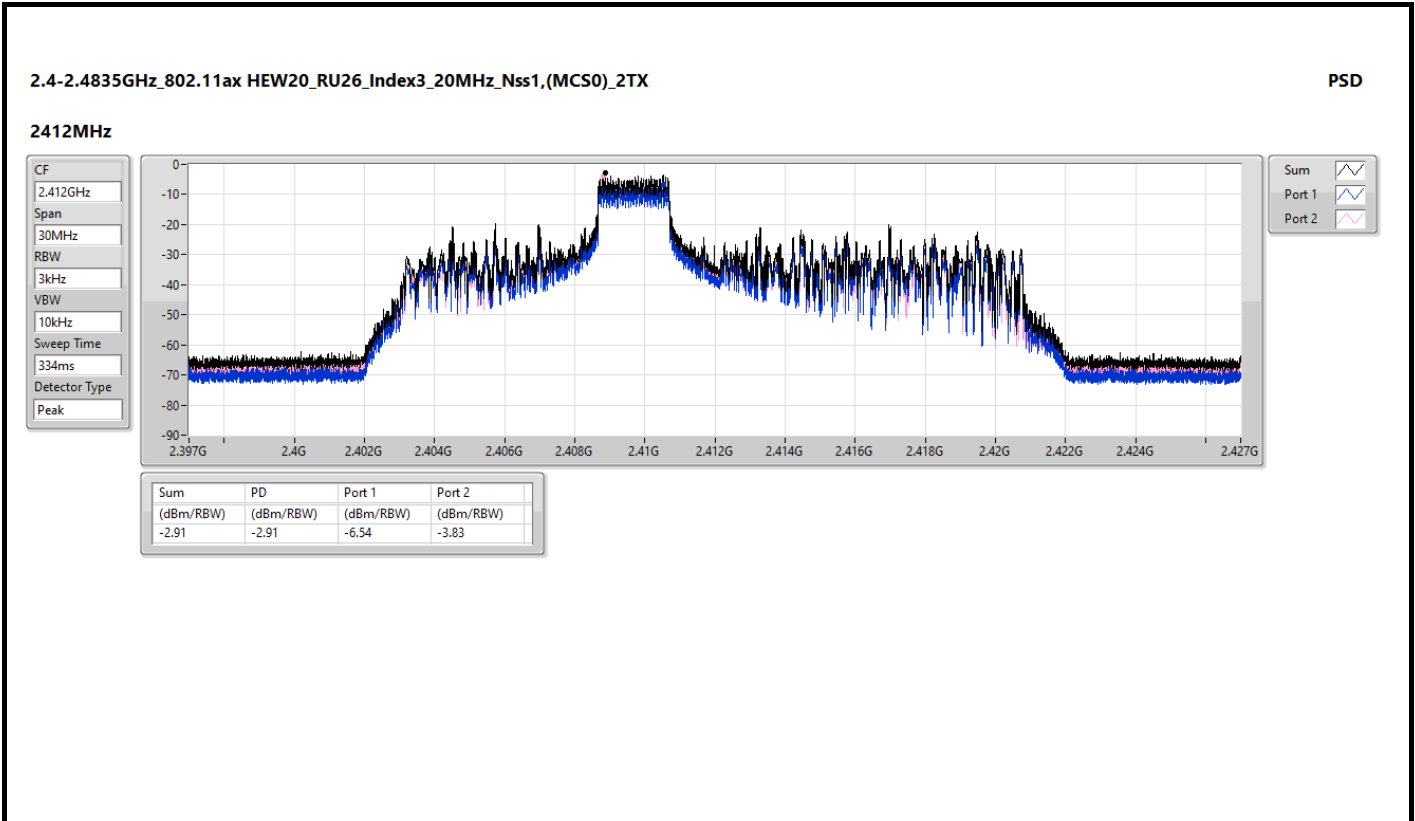

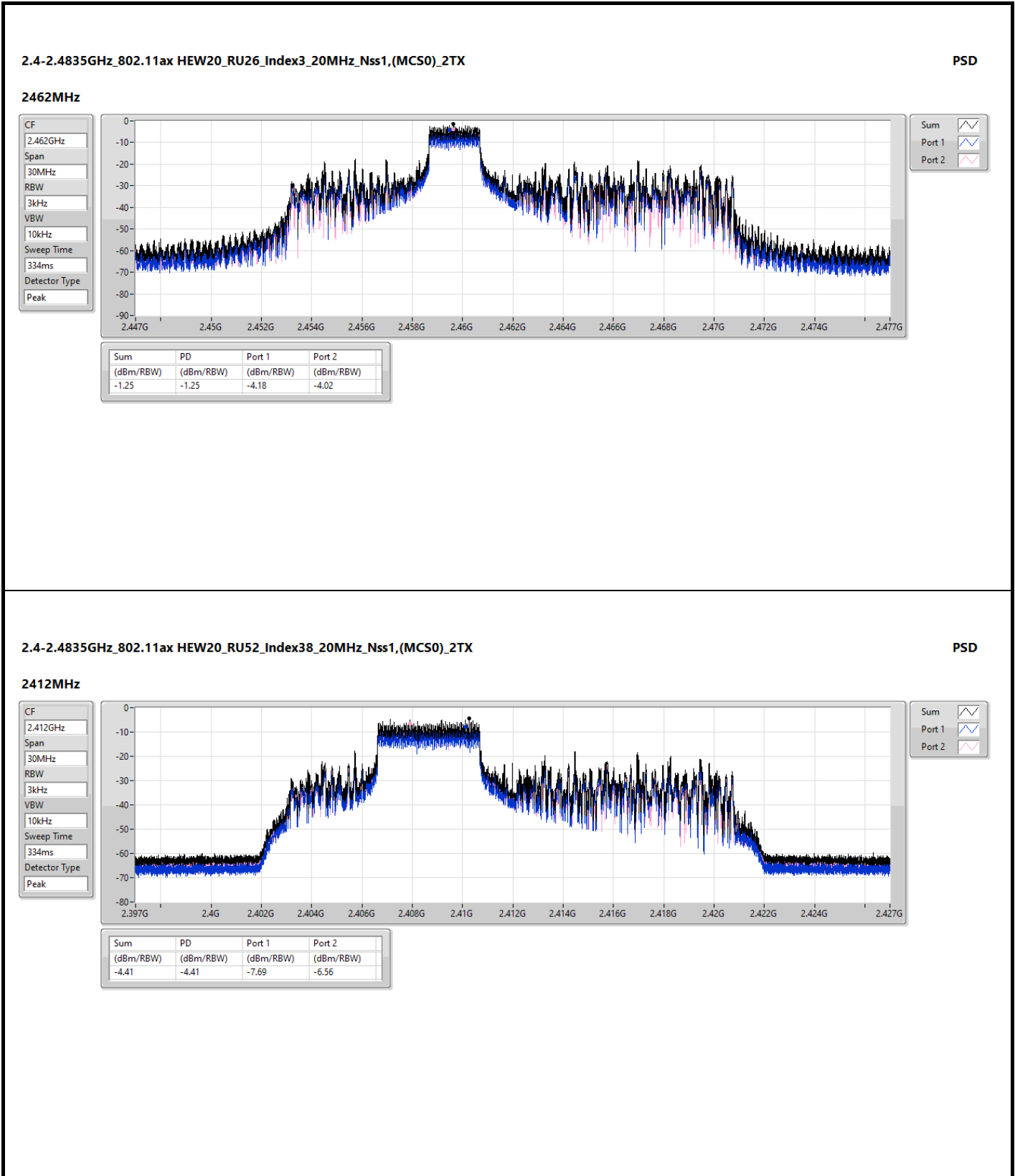



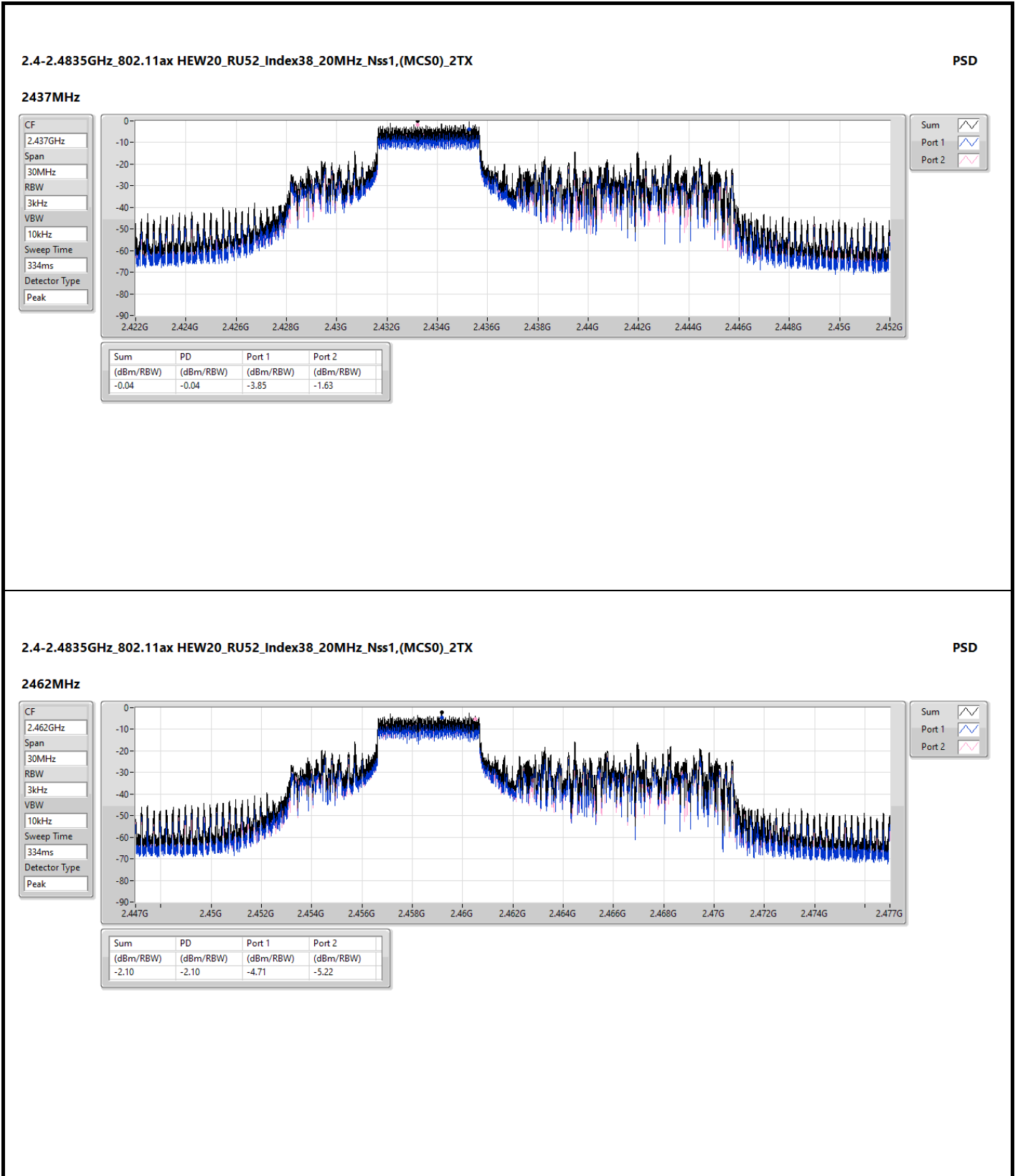



2.4-2.4835GHz\_802.11ax HEW20\_RU106\_Index53\_20MHz\_Nss1,(MCS0)\_2TX

PSD

2412MHz

CF  
2.412GHz  
Span  
30MHz  
RBW  
3kHz  
VBW  
10kHz  
Sweep Time  
334ms  
Detector Type  
Peak

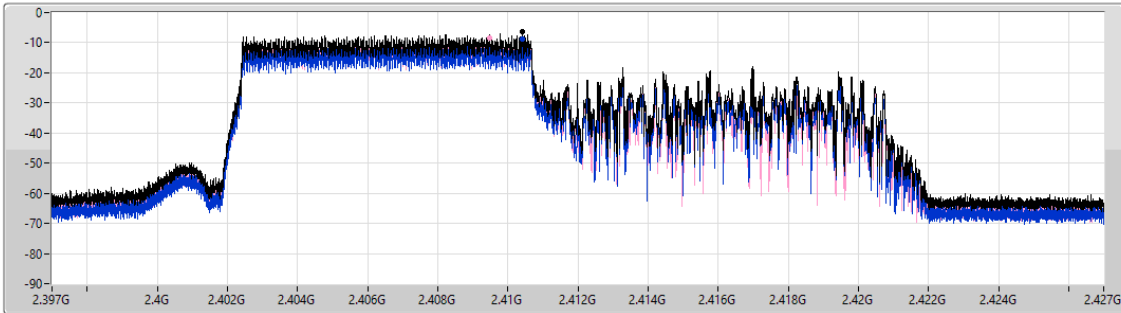

Sum  
Port 1  
Port 2

Sum	PD	Port 1	Port 2
(dBm/RBW)	(dBm/RBW)	(dBm/RBW)	(dBm/RBW)
-6.25	-6.25	-8.76	-8.32

2.4-2.4835GHz\_802.11ax HEW20\_RU106\_Index53\_20MHz\_Nss1,(MCS0)\_2TX

PSD

2437MHz

CF  
2.437GHz  
Span  
30MHz  
RBW  
3kHz  
VBW  
10kHz  
Sweep Time  
334ms  
Detector Type  
Peak

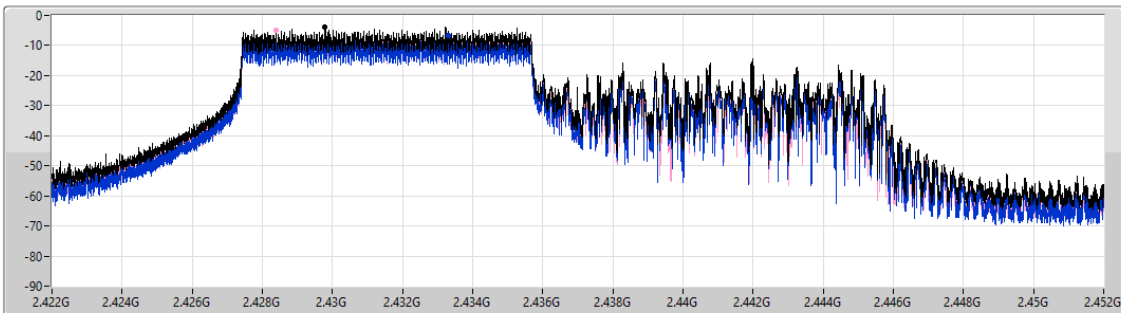

Sum  
Port 1  
Port 2

Sum	PD	Port 1	Port 2
(dBm/RBW)	(dBm/RBW)	(dBm/RBW)	(dBm/RBW)
-3.84	-3.84	-6.84	-5.08



2.4-2.4835GHz\_802.11ax HEW20\_RU106\_Index53\_20MHz\_Nss1,(MCS0)\_2TX

PSD

2462MHz

CF  
2.462GHz  
Span  
30MHz  
RBW  
3kHz  
VBW  
10kHz  
Sweep Time  
334ms  
Detector Type  
Peak

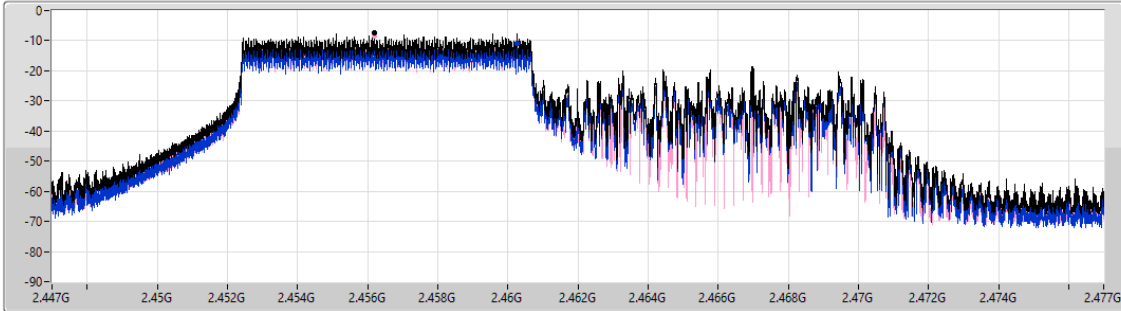

Sum  
Port 1  
Port 2

Sum	PD	Port 1	Port 2
(dBm/RBW)	(dBm/RBW)	(dBm/RBW)	(dBm/RBW)
-7.37	-7.37	-10.75	-8.51

2.4-2.4835GHz\_802.11ax HEW40\_RU26\_Index12\_40MHz\_Nss1,(MCS0)\_2TX

PSD

2422MHz

CF  
2.422GHz  
Span  
60MHz  
RBW  
3kHz  
VBW  
10kHz  
Sweep Time  
667ms  
Detector Type  
Peak

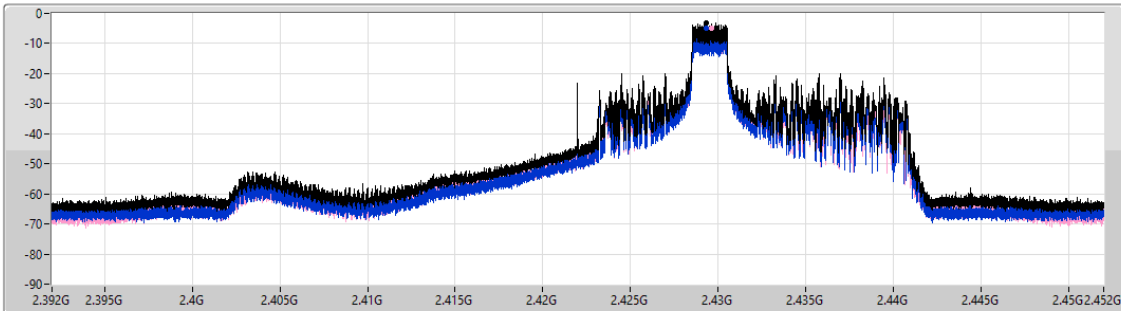

Sum  
Port 1  
Port 2

Sum	PD	Port 1	Port 2
(dBm/RBW)	(dBm/RBW)	(dBm/RBW)	(dBm/RBW)
-3.10	-3.10	-5.00	-4.88



2.4-2.4835GHz\_802.11ax HEW40\_RU26\_Index12\_40MHz\_Nss1,(MCS0)\_2TX

PSD

2437MHz

CF  
2.437GHz

Span  
60MHz

RBW  
3kHz

VBW  
10kHz

Sweep Time  
667ms

Detector Type  
Peak

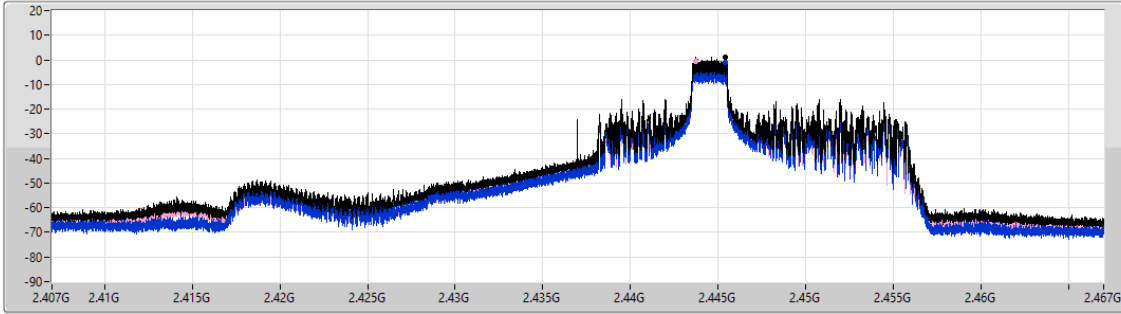

Sum

Port 1

Port 2

Sum	PD	Port 1	Port 2
(dBm/RBW)	(dBm/RBW)	(dBm/RBW)	(dBm/RBW)
1.24	1.24	-1.25	-0.60

2.4-2.4835GHz\_802.11ax HEW40\_RU26\_Index12\_40MHz\_Nss1,(MCS0)\_2TX

PSD

2452MHz

CF  
2.452GHz

Span  
60MHz

RBW  
3kHz

VBW  
10kHz

Sweep Time  
667ms

Detector Type  
Peak

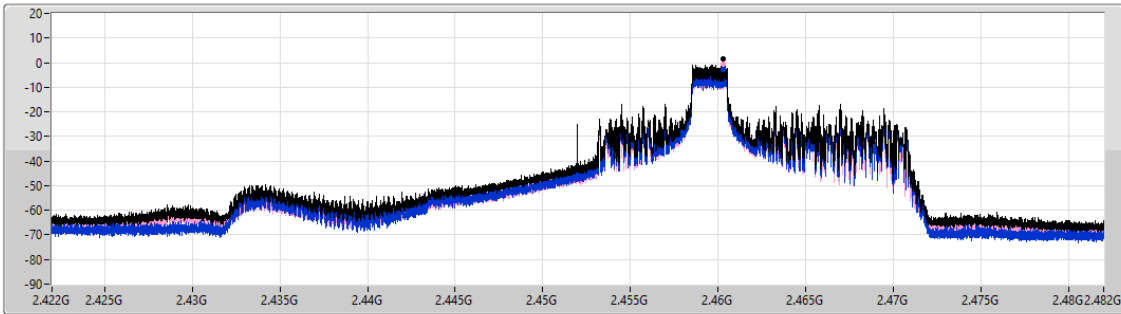

Sum

Port 1

Port 2

Sum	PD	Port 1	Port 2
(dBm/RBW)	(dBm/RBW)	(dBm/RBW)	(dBm/RBW)
1.35	1.35	-2.77	-0.77

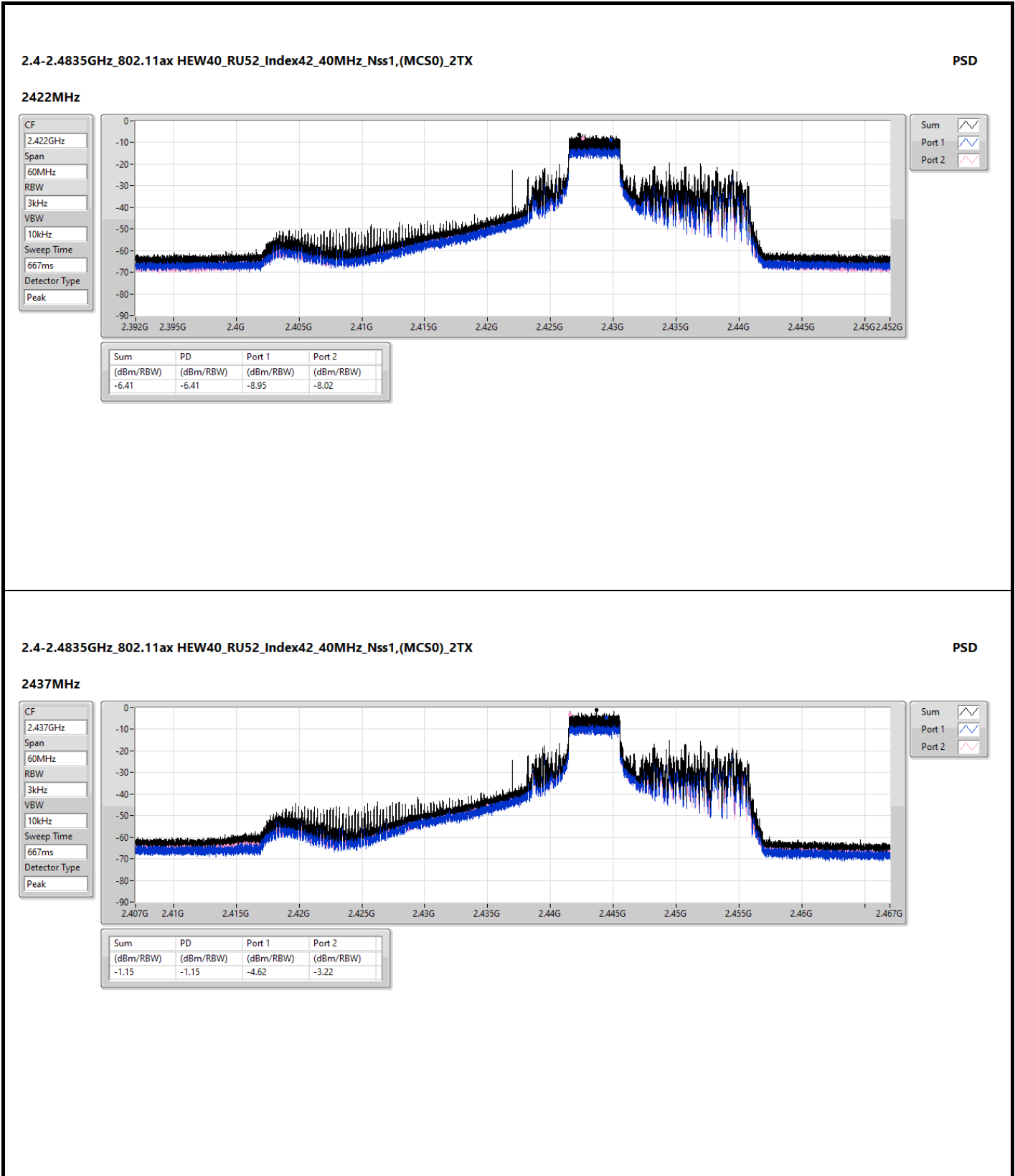



2.4-2.4835GHz\_802.11ax HEW40\_RU52\_Index42\_40MHz\_Nss1,(MCS0)\_2TX

PSD

2452MHz

CF  
2.452GHz  
Span  
60MHz  
RBW  
3kHz  
VBW  
10kHz  
Sweep Time  
667ms  
Detector Type  
Peak

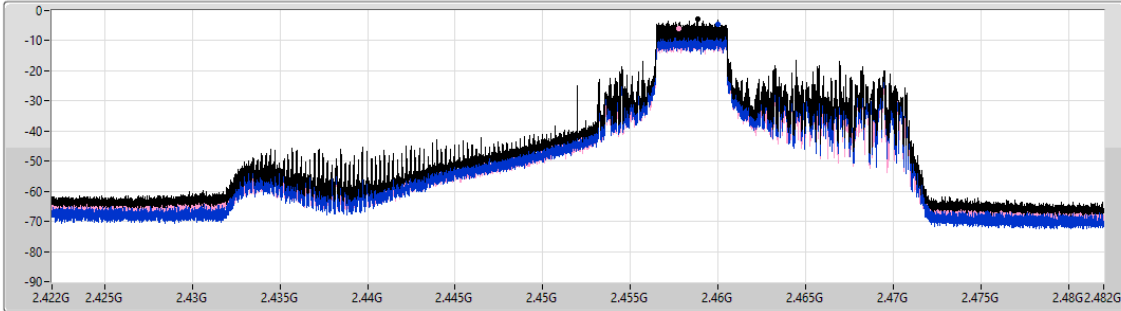

Sum  
Port 1  
Port 2

Sum	PD	Port 1	Port 2
(dBm/RBW)	(dBm/RBW)	(dBm/RBW)	(dBm/RBW)
-2.77	-2.77	-4.42	-6.09

2.4-2.4835GHz\_802.11ax HEW40\_RU106\_Index54\_40MHz\_Nss1,(MCS0)\_2TX

PSD

2422MHz

CF  
2.422GHz  
Span  
60MHz  
RBW  
3kHz  
VBW  
10kHz  
Sweep Time  
667ms  
Detector Type  
Peak

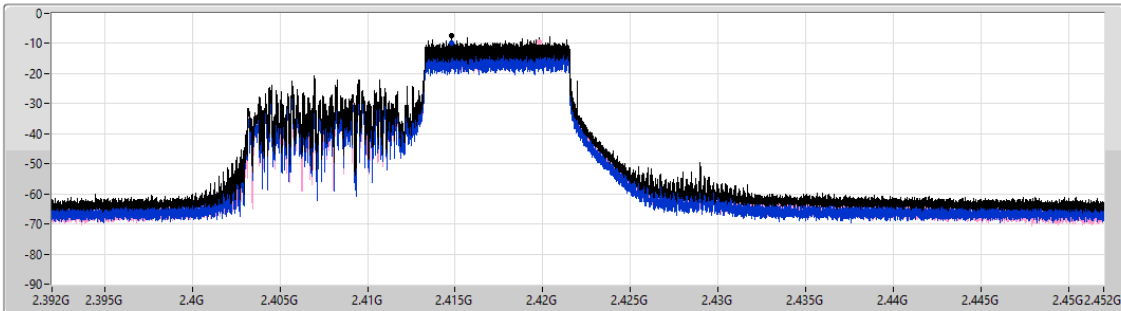

Sum  
Port 1  
Port 2

Sum	PD	Port 1	Port 2
(dBm/RBW)	(dBm/RBW)	(dBm/RBW)	(dBm/RBW)
-7.31	-7.31	-9.74	-9.35