

FCC Test Report

FCC ID : SQG-MT320
Equipment : WiFi 6 + Bluetooth 5.4 Module
Model No. : Sona MT320
Brand Name : Laird Connectivity
Applicant : Laird Connectivity LLC
Address : W66N220 Commerce Court, Cedarburg, WI
53012 United States Of America
Standard : 47 CFR FCC Part 15.407
Received Date : Sep. 25, 2023
Tested Date : Oct. 17 ~ Dec. 08, 2023

We, International Certification Corporation, would like to declare that the tested sample has been evaluated and in compliance with the requirement of the above standards. The test results contained in this report refer exclusively to the product. It shall not be reproduced except in full without the written approval of our laboratory.

Reviewed by:

Approved by:

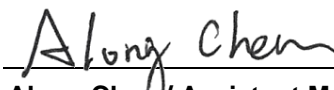

Along Chen / Assistant Manager



Gary Chang / Manager

Table of Contents

1	GENERAL DESCRIPTION	5
1.1	Information.....	5
1.2	Local Support Equipment List	16
1.3	Test Setup Chart	16
1.4	The Equipment List	18
1.5	Test Standards	19
1.6	Reference Guidance	19
1.7	Deviation from Test Standard and Measurement Procedure.....	19
1.8	Measurement Uncertainty	20
2	TEST CONFIGURATION.....	21
2.1	Testing Facility	21
2.2	The Worst Test Modes and Channel Details	22
2.3	Directional gain.....	26
3	TRANSMITTER TEST RESULTS	27
3.1	Emission Bandwidth	27
3.2	Conducted Output Power	28
3.3	Power Spectral Density	30
3.4	Unwanted Emissions.....	32
3.5	AC Power Line Conducted Emissions	35
4	TEST LABORATORY INFORMATION	36
Appendix A. Emission Bandwidth		
Appendix B. Conducted Output Power		
Appendix C. Power Spectral Density		
Appendix D. Unwanted Emissions		
Appendix E. AC Power Line Conducted Emissions		

Release Record

Report No.	Version	Description	Issued Date
FR392501-1AN	Rev. 01	Initial issue	Jan. 23, 2024
FR392501-1AN	Rev. 02	Product name changed	Feb. 08, 2024

Summary of Test Results

FCC Rules	Test Items	Measured	Result
15.207	AC Power Line Conducted Emissions	[dBuV]: 0.408MHz 32.26 (Margin -15.42dB) - AV	Pass
15.407(b) 15.209	Unwanted Emissions	[dBuV/m at 3m]: 17355.00MHz 61.37 (Margin -6.83dB) - PK	Pass
15.407(a)	Emission Bandwidth	Meet the requirement of limit	Pass
15.407(e)	6dB bandwidth	Meet the requirement of limit	Pass
15.407(a)	Conducted Output Power	Max Power [dBm]: Non-beamforming mode 5150~5250MHz: 19.15 5250~5350MHz: 19.03 5470~5725MHz: 22.43 5725~5850MHz: 22.70 Beamforming mode 5150~5250MHz: 16.14 5250~5350MHz: 16.02 5470~5725MHz: 19.42 5725~5850MHz: 19.69	Pass
15.407(a)	Power Spectral Density	Meet the requirement of limit	Pass
15.407(g)	Frequency Stability	Refer to report no.: FR392501AN	
15.203	Antenna Requirement	Meet the requirement of limit	Pass

Declaration of Conformity:

The test results with all measurement uncertainty excluded are presented in accordance with the regulation limits or requirements declared by manufacturers.

Comments and Explanations:

The declared of product specification for EUT presented in the report are provided by the manufacturer, and the manufacturer takes all the responsibilities for the accuracy of product specification.

1 General Description

1.1 Information

1.1.1 Product Details

The two configurations of the EUT are shown on the following:

Brand Name	Model Name	Description
Laird Connectivity	Sona MT320	MT320-SC (MHF4 connector on module)
		MT320-ST (RF trace variant)

1.1.2 Specification of the Equipment under Test (EUT)

RF General Information					
Frequency Range (MHz)	IEEE Std. 802.11	Ch. Freq. (MHz)	Channel Number	Transmit Chains (N _{TX})	Data Rate / MCS
5150-5250 5250-5350 5470-5725 5725-5850	a	5180-5240 5260-5320 5500-5720 5745-5825	36-48 [4] 52-64 [4] 100-144 [12] 149-165 [5]	2	6-54 Mbps
5150-5250 5250-5350 5470-5725 5725-5850	n (HT20)	5180-5240 5260-5320 5500-5720 5745-5825	36-48 [4] 52-64 [4] 100-144 [12] 149-165 [5]	2	MCS 0-15
5150-5250 5250-5350 5470-5725 5725-5850	n (HT40)	5190-5230 5270-5310 5510-5710 5755-5795	38-46 [2] 54-62 [2] 102-142 [6] 151-159 [2]	2	MCS 0-15
5150-5250 5250-5350 5470-5725 5725-5850	ac (VHT20)	5180-5240 5260-5320 5500-5720 5745-5825	36-48 [4] 52-64 [4] 100-144 [12] 149-165 [5]	2	MCS 0-9
5150-5250 5250-5350 5470-5725 5725-5850	ac (VHT40)	5190-5230 5270-5310 5510-5710 5755-5795	38-46 [2] 54-62 [2] 102-142 [6] 151-159 [2]	2	MCS 0-9
5150-5250 5250-5350 5470-5725 5725-5850	ac (VHT80)	5210 5290 5530~5690 5775	42 [1] 58 [1] 106-138 [3] 155 [1]	2	MCS 0-9
5150-5250 5250-5350 5470-5725 5725-5850	ax (HE20)	5180-5240 5260-5320 5500-5720 5745-5825	36-48 [4] 52-64 [4] 100-144 [12] 149-165 [5]	2	MCS 0-11
5150-5250 5250-5350 5470-5725 5725-5850	ax (HE40)	5190-5230 5270-5310 5510-5710 5755-5795	38-46 [2] 54-62 [2] 102-142 [6] 151-159 [2]	2	MCS 0-11
5150-5250 5250-5350 5470-5725 5725-5850	ax (HE80)	5210 5290 5530~5690 5775	42 [1] 58 [1] 106-138 [3] 155 [1]	2	MCS 0-11

Note 1: OFDM/OFDMA- BPSK, QPSK, 16QAM, 64QAM, 256QAM and 1024QAM modulation.
Note 2: 802.11n/ac/ax supports beamforming function.
Note 3: 802.11ax supports full RU and partial RU configuration. Test results of partial RU configuration are recorded in this report. Refers to report no.: FR392501AN for test results of full RU configuration.

1.1.3 Antenna Details

Ant. No.	Manufacturer	Model	Part Number	Type	Connector	Operating Frequencies / Gain (dBi)	
						2.4GHz	5GHz
1	-	FlexMIMO 6E	EFD2471A3 S-10MH4L	PIFA	MHF4L	2.2	3.8
2	-	FlexPIFA 6E	EFB2471A3 S-10MH4L	PIFA	MHF4L	2.2	3.9
3	-	Mini NanoBlade Flex 6 GHz	EMF2471A3 S-10MH4L	PCB Dipole	MHF4L	2.4	4.4
4	Joymax Electronics	Dipole 6E	TWX-100BR S3B	Dipole	RP-SMA	2	4

1.1.4 Power Supply Type of Equipment under Test (EUT)

Power Supply Type	3.3Vdc from host
--------------------------	------------------

1.1.5 Accessories

N/A

1.1.6 Channel List

802.11a / n HT20 / ac VHT20 / ax HE20		802.11n HT40 / ac VHT40 / ax HE40	
Channel	Frequency(MHz)	Channel	Frequency(MHz)
36	5180	38	5190
40	5200	46	5230
44	5220	54	5270
48	5240	62	5310
52	5260	102	5510
56	5280	110	5550
60	5300	118	5590
64	5320	126	5630
100	5500	134	5670
104	5520	142	5710
108	5540	151	5755
112	5560	159	5795
116	5580	802.11ac VHT80 / ax HE80	
120	5600	42	5210
124	5620	58	5290
128	5640	106	5530
132	5660	122	5610
136	5680	138	5690
140	5700	155	5775
144	5720	---	---
149	5745	---	---
153	5765	---	---
157	5785	---	---
161	5805	---	---
165	5825	---	---

1.1.7 Test Tool and Duty Cycle

Test Tool	QATool, version: 0.0.2.85		
Duty Cycle and Duty Factor	Mode	Duty Cycle (%)	Duty Factor (dB)
	ax HE20 RU26	90.00%	0.46
	ax HE20 RU52	90.13%	0.45
	ax HE20 RU106	87.79%	0.57
	ax HE40 RU26	76.84%	1.14
	ax HE40 RU52	89.33%	0.49
	ax HE40 RU106	88.53%	0.53
	ax HE40 RU242	77.52%	1.11
	ax HE80 RU26	90.16%	0.45
	ax HE80 RU52	90.44%	0.44
	ax HE80 RU106	88.90%	0.51
	ax HE80 RU242	86.19%	0.65
	ax HE80 RU484	75.68%	1.21

1.1.8 Power Index of Test Tool

SC Module

Modulation Mode	Test Frequency (MHz)	Power Index
ax HE20 RU26	5180	6.5
ax HE20 RU26	5200	6.5
ax HE20 RU26	5240	6
ax HE20 RU26	5260	6
ax HE20 RU26	5300	6.5
ax HE20 RU26	5320	6.5
ax HE20 RU26	5500	7
ax HE20 RU26	5580	7
ax HE20 RU26	5700	0.5
ax HE20 RU26	5720	7
ax HE20 RU26	5745	16.5
ax HE20 RU26	5785	16
ax HE20 RU26	5825	16
ax HE20 RU52	5180	9.5
ax HE20 RU52	5200	9.5
ax HE20 RU52	5240	9.5
ax HE20 RU52	5260	9.5

ax HE20 RU52	5300	9.5
ax HE20 RU52	5320	9.5
ax HE20 RU52	5500	10
ax HE20 RU52	5580	9.5
ax HE20 RU52	5700	4
ax HE20 RU52	5720	10
ax HE20 RU52	5745	16.5
ax HE20 RU52	5785	16.5
ax HE20 RU52	5825	16.5
ax HE20 RU106	5180	9
ax HE20 RU106	5200	12
ax HE20 RU106	5240	13
ax HE20 RU106	5260	12.5
ax HE20 RU106	5300	12
ax HE20 RU106	5320	8.5
ax HE20 RU106	5500	11.5
ax HE20 RU106	5580	12.5
ax HE20 RU106	5700	7.5
ax HE20 RU106	5720	12.5
ax HE20 RU106	5745	16
ax HE20 RU106	5785	16.5
ax HE20 RU106	5825	16.5
ax HE40 RU26	5190	6.5
ax HE40 RU26	5230	6.5
ax HE40 RU26	5270	6.5
ax HE40 RU26	5310	7
ax HE40 RU26	5510	6.5
ax HE40 RU26	5590	6.5
ax HE40 RU26	5670	2.5
ax HE40 RU26	5710	7
ax HE40 RU26	5755	11.5
ax HE40 RU26	5795	16
ax HE40 RU52	5190	7.5
ax HE40 RU52	5230	9.5
ax HE40 RU52	5270	9.5
ax HE40 RU52	5310	9.5

ax HE40 RU52	5510	8
ax HE40 RU52	5590	9.5
ax HE40 RU52	5670	6.5
ax HE40 RU52	5710	10
ax HE40 RU52	5755	14
ax HE40 RU52	5795	16
ax HE40 RU106	5190	8.5
ax HE40 RU106	5230	12
ax HE40 RU106	5270	12.5
ax HE40 RU106	5310	9
ax HE40 RU106	5510	9
ax HE40 RU106	5590	12
ax HE40 RU106	5670	9.5
ax HE40 RU106	5710	13
ax HE40 RU106	5755	15
ax HE40 RU106	5795	16
ax HE40 RU242	5190	8.5
ax HE40 RU242	5230	12
ax HE40 RU242	5270	13
ax HE40 RU242	5310	10
ax HE40 RU242	5510	10.5
ax HE40 RU242	5590	16
ax HE40 RU242	5670	12
ax HE40 RU242	5710	16
ax HE40 RU242	5755	16
ax HE40 RU242	5795	16.5
ax HE80 RU26	5210	6.5
ax HE80 RU26	5290	7
ax HE80 RU26	5530	6.5
ax HE80 RU26	5610	4.5
ax HE80 RU26	5690	7.5
ax HE80 RU26	5775	6.5
ax HE80 RU52	5210	8
ax HE80 RU52	5290	8.5
ax HE80 RU52	5530	8.5
ax HE80 RU52	5610	8

ax HE80 RU52	5690	10.5
ax HE80 RU52	5775	8.5
ax HE80 RU106	5210	9
ax HE80 RU106	5290	9.5
ax HE80 RU106	5530	8.5
ax HE80 RU106	5610	11.5
ax HE80 RU106	5690	13
ax HE80 RU106	5775	11
ax HE80 RU242	5210	9
ax HE80 RU242	5290	10
ax HE80 RU242	5530	11
ax HE80 RU242	5610	11.5
ax HE80 RU242	5690	16
ax HE80 RU242	5775	11.5
ax HE80 RU484	5210	9
ax HE80 RU484	5290	9
ax HE80 RU484	5530	9
ax HE80 RU484	5610	13.5
ax HE80 RU484	5690	16
ax HE80 RU484	5775	13.5

ST Module

Modulation Mode	Test Frequency (MHz)	Power Index
ax HE20 RU26	5180	6.5
ax HE20 RU26	5200	6.5
ax HE20 RU26	5240	6
ax HE20 RU26	5260	6
ax HE20 RU26	5300	6
ax HE20 RU26	5320	6
ax HE20 RU26	5500	6.5
ax HE20 RU26	5580	6.5
ax HE20 RU26	5700	1
ax HE20 RU26	5720	7
ax HE20 RU26	5745	16
ax HE20 RU26	5785	16
ax HE20 RU26	5825	16
ax HE20 RU52	5180	9.5

ax HE20 RU52	5200	9.5
ax HE20 RU52	5240	9
ax HE20 RU52	5260	9
ax HE20 RU52	5300	9
ax HE20 RU52	5320	9
ax HE20 RU52	5500	9.5
ax HE20 RU52	5580	9.5
ax HE20 RU52	5700	4
ax HE20 RU52	5720	10
ax HE20 RU52	5745	16
ax HE20 RU52	5785	16.5
ax HE20 RU52	5825	16.5
ax HE20 RU106	5180	9
ax HE20 RU106	5200	12
ax HE20 RU106	5240	13
ax HE20 RU106	5260	13
ax HE20 RU106	5300	11
ax HE20 RU106	5320	7.5
ax HE20 RU106	5500	11
ax HE20 RU106	5580	12.5
ax HE20 RU106	5700	7.5
ax HE20 RU106	5720	12.5
ax HE20 RU106	5745	16
ax HE20 RU106	5785	16.5
ax HE20 RU106	5825	16.5
ax HE40 RU26	5190	6.5
ax HE40 RU26	5230	6.5
ax HE40 RU26	5270	6
ax HE40 RU26	5310	6
ax HE40 RU26	5510	6
ax HE40 RU26	5590	6.5
ax HE40 RU26	5670	2.5
ax HE40 RU26	5710	7
ax HE40 RU26	5755	11
ax HE40 RU26	5795	16
ax HE40 RU52	5190	7.5

ax HE40 RU52	5230	9
ax HE40 RU52	5270	9
ax HE40 RU52	5310	8.5
ax HE40 RU52	5510	7.5
ax HE40 RU52	5590	9.5
ax HE40 RU52	5670	6.5
ax HE40 RU52	5710	9.5
ax HE40 RU52	5755	14
ax HE40 RU52	5795	16
ax HE40 RU106	5190	8.5
ax HE40 RU106	5230	12
ax HE40 RU106	5270	12.5
ax HE40 RU106	5310	8
ax HE40 RU106	5510	8.5
ax HE40 RU106	5590	12
ax HE40 RU106	5670	9.5
ax HE40 RU106	5710	13
ax HE40 RU106	5755	15
ax HE40 RU106	5795	16
ax HE40 RU242	5190	8.5
ax HE40 RU242	5230	12
ax HE40 RU242	5270	13
ax HE40 RU242	5310	9
ax HE40 RU242	5510	10
ax HE40 RU242	5590	16
ax HE40 RU242	5670	12
ax HE40 RU242	5710	16
ax HE40 RU242	5755	16
ax HE40 RU242	5795	16.5
ax HE80 RU26	5210	6.5
ax HE80 RU26	5290	6.5
ax HE80 RU26	5530	6
ax HE80 RU26	5610	4.5
ax HE80 RU26	5690	7.5
ax HE80 RU26	5775	6.5
ax HE80 RU52	5210	8

ax HE80 RU52	5290	8
ax HE80 RU52	5530	8
ax HE80 RU52	5610	8
ax HE80 RU52	5690	10.5
ax HE80 RU52	5775	8.5
ax HE80 RU106	5210	9
ax HE80 RU106	5290	9.5
ax HE80 RU106	5530	8.5
ax HE80 RU106	5610	11.5
ax HE80 RU106	5690	13
ax HE80 RU106	5775	11
ax HE80 RU242	5210	9
ax HE80 RU242	5290	10
ax HE80 RU242	5530	10.5
ax HE80 RU242	5610	12
ax HE80 RU242	5690	16
ax HE80 RU242	5775	11.5
ax HE80 RU484	5210	9
ax HE80 RU484	5290	9
ax HE80 RU484	5530	8.5
ax HE80 RU484	5610	13.5
ax HE80 RU484	5690	16
ax HE80 RU484	5775	14

1.2 Local Support Equipment List

Support Equipment List					
No.	Equipment	Brand	Model	FCC ID	Remarks
1	Laptop	DELL	Latitude 5400	DoC	---
2	Fixture	---	---	---	Provided by applicant.
3	Fixture's adapter	---	---	---	Provided by applicant. I/P: 100-240Vac, 1.5A, 50-60Hz O/P: 5.0V 3.0A
4	Carrier board	---	---	---	Provided by applicant.
5	50Ω terminator	---	---	---	---

Note: The support laptop was disconnected from EUT and was removed from testing table after sending command to EUT to transmit continuously.

1.3 Test Setup Chart

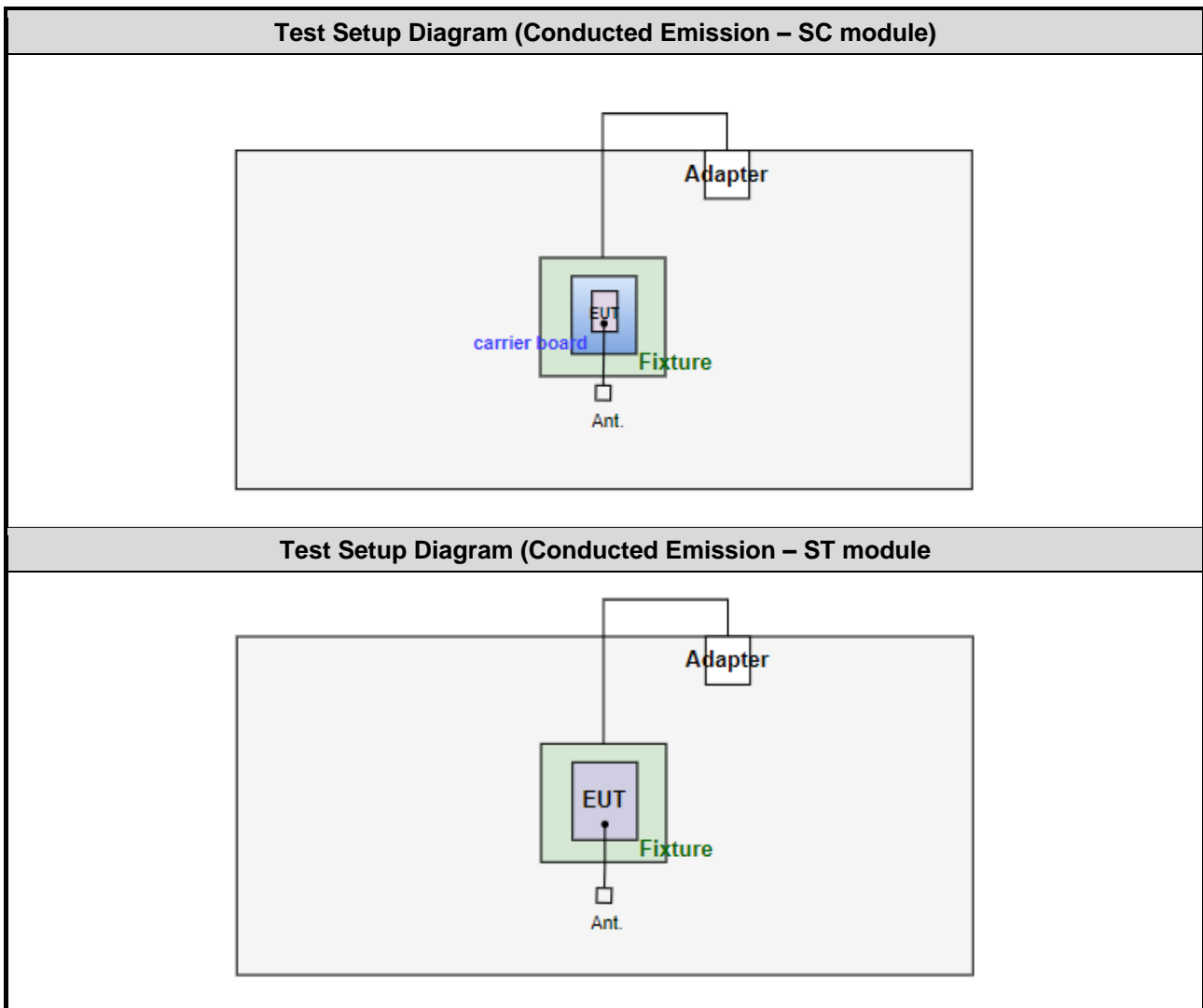

Test Setup Diagram (Radiated Emission – SC module)

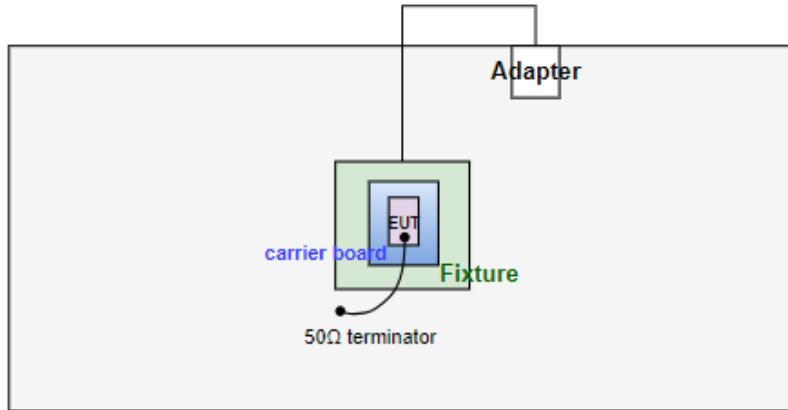

Test Setup Diagram (Radiated Emission – ST module)

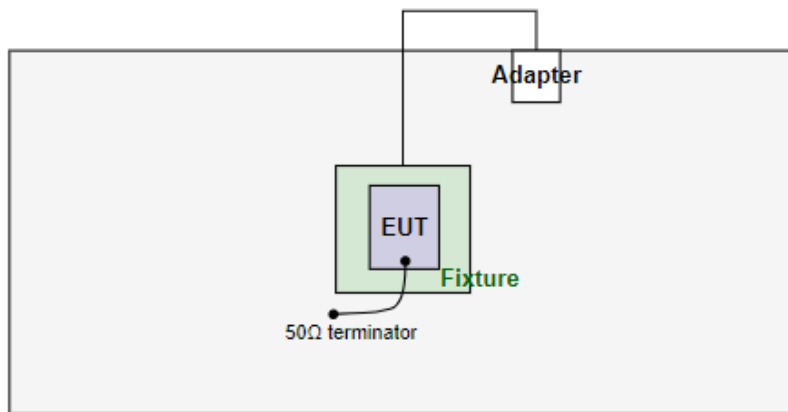

1.4 The Equipment List

Test Item	Conducted Emission				
Test Site	Conduction room 1 / (CO01-WS)				
Tested Date	Dec. 08, 2023				
Instrument	Brand	Model No.	Serial No.	Calibration Date	Calibration Until
Receiver	R&S	ESR3	101658	Feb. 17, 2023	Feb. 16, 2024
LISN	R&S	ENV216	101579	May. 09, 2023	May. 08, 2024
LISN (Support Unit)	SCHWARZBECK	Schwarzbeck 8127	8127667	Jan. 03, 2023	Jan. 02, 2024
RF Cable-CON	Woken	CFD200-NL	CFD200-NL-001	Oct. 11, 2023	Oct. 10, 2024
50 ohm terminal (Support Unit)	NA	50	01	Jun. 14, 2023	Jun. 13, 2024
Measurement Software	AUDIX	e3	6.120210k	NA	NA
Note: Calibration Interval of instruments listed above is one year.					

Test Item	Radiated Emission				
Test Site	966 chamber1 / (03CH01-WS)				
Tested Date	Oct. 20 ~ Oct. 25, 2023				
Instrument	Brand	Model No.	Serial No.	Calibration Date	Calibration Until
Receiver	R&S	ESR3	101657	Mar. 03, 2023	Mar. 02, 2024
Spectrum Analyzer	R&S	FSV40	101498	Nov. 21, 2022	Nov. 20, 2023
Loop Antenna	R&S	HFH2-Z2	100330	Nov. 01, 2022	Oct. 31, 2023
Bilog Antenna	SCHWARZBECK	VULB9168	VULB9168-522	Jul. 31, 2023	Jul. 30, 2024
Horn Antenna 1G-18G	SCHWARZBECK	BBHA 9120 D	BBHA 9120 D 1096	Nov. 25, 2022	Nov. 24, 2023
Horn Antenna 18G-40G	SCHWARZBECK	BBHA 9170	BBHA 9170517	Oct. 27, 2022	Oct. 26, 2023
Preamplifier	EMC	EMC02325	980225	Jun. 28, 2023	Jun. 27, 2024
Preamplifier	EMC	EMC118A45SE	980898	Jul. 14, 2023	Jul. 13, 2024
Preamplifier	EMC	EMC184045SE	980903	Jul. 17, 2023	Jul. 16, 2024
Loop Antenna Cable	KOAX KABEL	101354-BW	101354-BW	Oct. 03, 2023	Oct. 02, 2024
LF cable 3M	Woken	CFD400NL-LW	CFD400NL-001	Oct. 03, 2023	Oct. 02, 2024
LF cable 11M	EMC	EMCCFD400-NW-NW-1 1000	200801	Oct. 03, 2023	Oct. 02, 2024
LF cable 1M	EMC	EMCCFD400-NM-NM-1 000	160502	Oct. 03, 2023	Oct. 02, 2024
RF Cable	EMC	EMC104-35M-35M-8000	210920	Oct. 03, 2023	Oct. 02, 2024
RF Cable	EMC	EMC104-35M-35M-3000	210922	Oct. 03, 2023	Oct. 02, 2024
Measurement Software	AUDIX	e3	6.120210g	NA	NA
Note: Calibration Interval of instruments listed above is one year.					

Test Item	RF Conducted				
Test Site	(TH01-WS)				
Tested Date	Oct. 17 ~ Nov. 28, 2023				
Instrument	Brand	Model No.	Serial No.	Calibration Date	Calibration Until
Spectrum Analyzer	R&S	FSV40	101910	Apr. 14, 2023	Apr. 13, 2024
Power Meter	Anritsu	ML2495A	1241001	Jan. 11, 2023	Jan. 10, 2024
Power Sensor	Anritsu	MA2411B	1911228	Jan. 11, 2023	Jan. 10, 2024
TEMP&HUMIDITY CHAMBER	GIANT FORCE	GCT-225-40-SP-SD	MAF1212-002	Jun. 21, 2023	Jun. 20, 2024
AC POWER SOURCE	APC	AFC-500W	F312060012	Dec. 09, 2022	Dec. 08, 2023
Attenuator	Pasternack	PE7005-10	10-2	Oct. 05, 2023	Oct. 04, 2024
HIGHPASS FILTER 7-18G	K&L	11SH10-7000/T18000-O/OP	18	Oct. 05, 2023	Oct. 04, 2024
LOWPASS FILTER	WI	WLKS1100-12SS	2	Oct. 05, 2023	Oct. 04, 2024
LOWPASS FILTER	WI	WLKS5000-12SS	1	Oct. 05, 2023	Oct. 04, 2024
Measurement Software	Sporton	SENSE-15407_NII	V5.11	NA	NA
Note: Calibration Interval of instruments listed above is one year.					

1.5 Test Standards

47 CFR FCC Part 15.407
ANSI C63.10-2013

1.6 Reference Guidance

FCC KDB 412172 D01 Determining ERP and EIRP v01r01
FCC KDB 662911 D01 Multiple Transmitter Output v02r01
FCC KDB 789033 D02 General UNII Test Procedures New Rules v02r01

1.7 Deviation from Test Standard and Measurement Procedure

None

1.8 Measurement Uncertainty

The measurement uncertainties given below are based on a 95% confidence level (based on a coverage factor (k=2)).

Measurement Uncertainty	
Parameters	Uncertainty
Bandwidth	±34.130 Hz
Conducted power	±0.808 dB
Frequency error	±1×10 ⁻⁹
Power density	±0.583 dB
Conducted emission	±2.715 dB
AC conducted emission	±2.92 dB
Unwanted Emission ≤ 1GHz	±3.41 dB
Unwanted Emission > 1GHz	±4.59 dB
Time	±0.1%
Temperature	±0.4 °C

2 Test Configuration

2.1 Testing Facility

Test Laboratory	International Certification Corporation
Test Site	CO01-WS, 03CH01-WS, TH01-WS
Address of Test Site	No.3-1, Lane 6, Wen San 3rd St., Kwei Shan Dist., Tao Yuan City 33381, Taiwan (R.O.C.)

- FCC Designation No.: TW2732
- FCC site registration No.: 181692
- ISED#: 10807A
- CAB identifier: TW2732

2.2 The Worst Test Modes and Channel Details

Frequency band 5150~5350 MHz / 5470~5725 MHz							
Test item	Modulation Mode	Test Frequency (MHz)	Data Rate	Test method	Mode	Test Configuration	Note
Non-beamforming mode							
AC Power Line Conducted Emissions	ax HE80 RU242	5690	MCS 0	Conducted	TX	1	-
Unwanted Emissions ≤1GHz	ax HE80 RU242	5690	MCS 0	Radiated	TX	1, 2	Note 2
Unwanted Emissions >1GHz	ax HE20 RU26 ax HE20 RU52 ax HE20 RU106	5180 / 5200 / 5240 / 5260 / 5300 / 5320 / 5500 / 5580 / 5700 / 5720	MCS 0	Radiated	TX	1	Note 2
	ax HE40 RU242	5190 / 5230 / 5270 / 5310 / 5510 / 5590 / 5670 / 5710	MCS 0				
	ax HE80 RU484	5210 / 5290 / 5530 / 5610 / 5690	MCS 0				
	ax HE20 RU106 ax HE20 RU52 ax HE20 RU26	5180 5320 5720	MCS 0	Radiated	TX	2	Note 2
Unwanted Emissions ≤1GHz	ax HE80 RU242	5690	MCS 0	Conducted	TX	1, 2	-
Unwanted Emissions >1GHz	ax HE20 RU26 ax HE20 RU52 ax HE20 RU106	5180 / 5200 / 5240 / 5260 / 5300 / 5320 / 5500 / 5580 / 5700 / 5720	MCS 0	Conducted	TX	1	-
	ax HE40 RU26 ax HE40 RU52 ax HE40 RU106 ax HE40 RU242	5190 / 5230 / 5270 / 5310 / 5510 / 5590 / 5670 / 5710	MCS 0				
	ax HE80 RU26 ax HE80 RU52 ax HE80 RU106 ax HE80 RU242 ax HE80 RU484	5210 / 5290 / 5530 / 5610 / 5690	MCS 0				
	ax HE20 RU106 ax HE40 RU26 ax HE80 RU242	5200 5310 5530	MCS 0	Conducted	TX	2	-

Frequency band 5150~5350 MHz / 5470~5725 MHz							
Test item	Modulation Mode	Test Frequency (MHz)	Data Rate	Test method	Mode	Test Configuration	Note
Conducted Output Power	ax HE20 RU26 ax HE20 RU52 ax HE20 RU106	5180 / 5200 / 5240 / 5260 / 5300 / 5320 / 5500 / 5580 / 5700 / 5720	MCS 0	Conducted	TX	1, 2	-
	ax HE40 RU26 ax HE40 RU52 ax HE40 RU106 ax HE40 RU242	5190 / 5230 / 5270 / 5310 / 5510 / 5590 / 5670 / 5710	MCS 0				
	ax HE80 RU26 ax HE80 RU52 ax HE80 RU106 ax HE80 RU242 ax HE80 RU484	5210 / 5290 / 5530 / 5610 / 5690	MCS 0				
Emission Bandwidth Power Spectral Density	ax HE20 RU26 ax HE20 RU52 ax HE20 RU106	5180 / 5200 / 5240 / 5260 / 5300 / 5320 / 5500 / 5580 / 5700 / 5720	MCS 0	Conducted	TX	1	-
	ax HE40 RU26 ax HE40 RU52 ax HE40 RU106 ax HE40 RU242	5190 / 5230 / 5270 / 5310 / 5510 / 5590 / 5670 / 5710	MCS 0				
	ax HE80 RU26 ax HE80 RU52 ax HE80 RU106 ax HE80 RU242 ax HE80 RU484	5210 / 5290 / 5530 / 5610 / 5690	MCS 0				
Beamforming mode							
Conducted Output Power	ax HE20 RU26 ax HE20 RU52 ax HE20 RU106	5180 / 5200 / 5240 / 5260 / 5300 / 5320 / 5500 / 5580 / 5700 / 5720	MCS 0	Conducted	TX	1, 2	-
	ax HE40 RU26 ax HE40 RU52 ax HE40 RU106 ax HE40 RU242	5190 / 5230 / 5270 / 5310 / 5510 / 5590 / 5670 / 5710	MCS 0				
	ax HE80 RU26 ax HE80 RU52 ax HE80 RU106 ax HE80 RU242 ax HE80 RU484	5210 / 5290 / 5530 / 5610 / 5690	MCS 0				
NOTE:							
<ol style="list-style-type: none"> The EUT was pretested with 3 orientations placed on the table for the radiated emission measurement – X, Y, and Z-plane. The Y-plane result was found as the worst case and was shown in this report. The 50Ω terminator is connected to antenna port of EUT for radiated emission measurement. Beamforming mode is calculated not measured. The calculation method is conducted power of non-beamforming – 3.01 dB. Test configurations are listed as below: Configuration 1: SC Module Configuration 2: ST Module 							

Frequency band 5725-5850 MHz							
Test item	Modulation Mode	Test Frequency (MHz)	Data Rate	Test method	Mode	Test Configuration	Note
Non-beamforming mode							
AC Power Line Conducted Emission	ax HE20 RU106	5825	MCS 0	Conducted	TX	1	-
Unwanted Emissions ≤ 1GHz	ax HE20 RU106	5825	MCS 0	Radiated	TX	1, 2	Note 2
Unwanted Emissions >1GHz	ax HE20 RU26 ax HE20 RU52 ax HE20 RU106	5745 / 5785 / 5825	MCS 0	Radiated	TX	1	Note 2
	ax HE40 RU242	5755 / 5795	MCS 0				
	ax HE80 RU484	5775	MCS 0				
	ax HE20 RU106	5785	MCS 0	Radiated	TX	2	Note 2
Unwanted Emissions ≤ 1GHz	ax HE20 RU106	5825	MCS 0	Conducted	TX	1, 2	-
Unwanted Emissions >1GHz	ax HE20 RU26 ax HE20 RU52 ax HE20 RU106	5745 / 5785 / 5825	MCS 0	Conducted	TX	1	-
	ax HE40 RU26 ax HE40 RU52 ax HE40 RU106 ax HE40 RU242	5755 / 5795	MCS 0				
	ax HE80 RU26 ax HE80 RU52 ax HE80 RU106 ax HE80 RU242 ax HE80 RU484	5775	MCS 0				
	ax HE20 RU26	5785	MCS 0	Conducted	TX	2	-
Conducted Output Power	ax HE20 RU26 ax HE20 RU52 ax HE20 RU106	5745 / 5785 / 5825	MCS 0	Conducted	TX	1, 2	-
	ax HE40 RU26 ax HE40 RU52 ax HE40 RU106 ax HE40 RU242	5755 / 5795	MCS 0				
	ax HE80 RU26 ax HE80 RU52 ax HE80 RU106 ax HE80 RU242 ax HE80 RU484	5775	MCS 0				

Frequency band 5725-5850 MHz							
Test item	Modulation Mode	Test Frequency (MHz)	Data Rate	Test method	Mode	Test Configuration	Note
6dB bandwidth Power spectral density	ax HE20 RU26 ax HE20 RU52 ax HE20 RU106	5745 / 5785 / 5825	MCS 0	Conducted	TX	1	-
	ax HE40 RU26 ax HE40 RU52 ax HE40 RU106 ax HE40 RU242	5755 / 5795	MCS 0				
	ax HE80 RU26 ax HE80 RU52 ax HE80 RU106 ax HE80 RU242 ax HE80 RU484	5775	MCS 0				
Beamforming mode							
Conducted Output Power	ax HE20 RU26 ax HE20 RU52 ax HE20 RU106	5745 / 5785 / 5825	MCS 0	Conducted	TX	1, 2	-
	ax HE40 RU26 ax HE40 RU52 ax HE40 RU106 ax HE40 RU242	5755 / 5795	MCS 0				
	ax HE80 RU26 ax HE80 RU52 ax HE80 RU106 ax HE80 RU242 ax HE80 RU484	5775	MCS 0				
NOTE:							
<ol style="list-style-type: none"> The EUT was pretested with 3 orientations placed on the table for the radiated emission measurement – X, Y, and Z-plane. The Y-plane result was found as the worst case and was shown in this report. The 50Ω terminator is connected to antenna port of EUT for radiated emission measurement. Beamforming mode is calculated not measured. The calculation method is conducted power of non-beamforming – 3.01 dB. Test configurations are listed as below: Configuration 1: SC Module Configuration 2: ST Module 							

2.3 Directional gain

Directional gain is calculated by following formula from FCC KDB 662911 D01 section F)2)f)(i)

Directional gain = G_{ANT} + Array Gain;
For Power measurement (Non-Beamforming)

Array gain = 0 dB for $N_{ANT} \leq 4$;

For Power spectral density / out of band emission (conducted measurement) / Power measurement (Beamforming)

Array gain = $10 \cdot \log(N_{ANT}/N_{SS})$ dB;

Directional gain is calculated as below

Test item	G_{ANT} (dBi)	Array gain (dB)	Directional gain (dBi)
Output power (Non-Beamforming)	4.4	0	4.4
Output power (Beamforming)	4.4	3.01	7.41
Power spectral density	4.4	3.01	7.41
Out of band emission(conducted measurement)	4.4	3.01	7.41

3 Transmitter Test Results

3.1 Emission Bandwidth

3.1.1 Limit of Emission Bandwidth

Within the 5.725-5.85 GHz band, the minimum 6 dB bandwidth of U-NII devices shall be at least 500 kHz.

3.1.2 Test Procedures

26dB Bandwidth

1. Set RBW = approximately 1% of the emission bandwidth.
2. Set the VBW > RBW, Detector = Peak.
3. Trace mode = max hold.
4. Measure the maximum width of the emission that is 26 dB down from the peak of the emission.

Occupied Bandwidth

1. Set RBW = 1 % to 5 % of the OBW.
2. Set VBW \geq 3 RBW.
3. Sample detection and single sweep mode shall be used.
4. Use the 99 % power bandwidth function of the instrument.

6dB Bandwidth

1. Set RBW = 100kHz, VBW = 300kHz.
2. Detector = Peak, Trace mode = max hold.
3. Allow the trace to stabilize.
4. Measure the maximum width of the emission that is constrained by the frequencies associated with the two outermost amplitude points (upper and lower frequencies) that are attenuated by 6 dB relative to the maximum level measured in the fundamental emission.

3.1.3 Test Setup

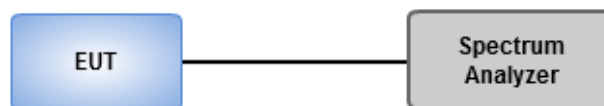

3.1.4 Test Results

Ambient Condition	22-23°C / 65-67%	Tested By	Akun Chung
--------------------------	------------------	------------------	------------

Refer to Appendix A.

3.2 Conducted Output Power

3.2.1 Limit of Conducted Output Power

Frequency band 5150-5250 MHz	
Operating Mode	Limit
<input type="checkbox"/> Outdoor access point	Conducted Power: 1 W The maximum e.i.r.p. at any elevation angle above 30 degrees as measured from the horizon must not exceed 125 mW (21 dBm)
<input type="checkbox"/> Indoor access point	Conducted Power: 1 W
<input type="checkbox"/> Fixed point-to-point access points	Conducted Power: 1 W
<input checked="" type="checkbox"/> Client devices	Conducted Power: 250 mW

Frequency Band (MHz)	Limit
<input checked="" type="checkbox"/> 5250 ~ 5350	Conducted Power: 250mW or 11dBm+10 log B
<input checked="" type="checkbox"/> 5470 ~ 5725	Conducted Power: 250mW or 11dBm+10 log B
<input checked="" type="checkbox"/> 5725 ~ 5850	Conducted Power: 1 W

Note: "B" is the 26dB emission bandwidth in MHz.

3.2.2 Test Procedures

Method PM-G (Measurement using a gated RF average power meter)

Measurements is performed using a wideband gated RF power meter provided that the gate parameters are adjusted such that the power is measured only when the EUT is transmitting at its maximum power control level. Since the measurement is made only during the ON time of the transmitter, no duty cycle correction factor is required.

Spectrum analyzer (For channel that extends across the 5.725 GHz boundary)

1. Set RBW = 1MHz, VBW = 3MHz, Sweep time = Auto, Detector = RMS.
2. Trace average at least 100 traces in power averaging mode.
3. Compute power by integrating the spectrum across the 26 dB EBW.
4. Add $10 \log(1/X)$, X:duty cycle) if duty cycle is <98%).

3.2.3 Test Setup

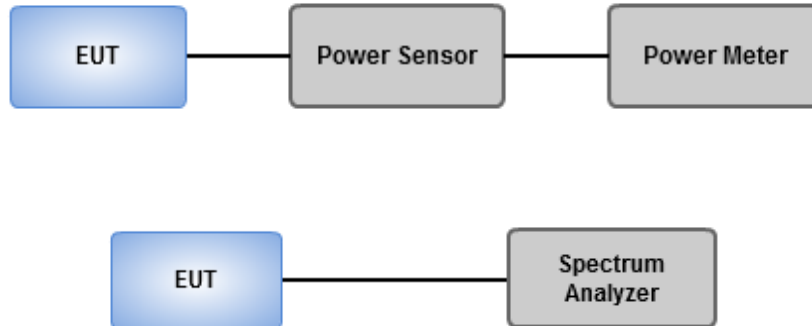

3.2.4 Test Results

Ambient Condition	22-23°C / 65-67%	Tested By	Akun Chung
--------------------------	------------------	------------------	------------

Refer to Appendix B.

3.3 Power Spectral Density

3.3.1 Limit of Power Spectral Density

Frequency band 5150-5250 MHz		
Operating Mode		Limit
<input type="checkbox"/>	Outdoor access point	17 dBm / MHz
<input type="checkbox"/>	Indoor access point	17 dBm / MHz
<input type="checkbox"/>	Fixed point-to-point access points	17 dBm / MHz
<input checked="" type="checkbox"/>	Client devices	11 dBm / MHz

Frequency Band (MHz)		Limit
<input checked="" type="checkbox"/>	5250 ~ 5350	11 dBm / MHz
<input checked="" type="checkbox"/>	5470 ~ 5725	11 dBm / MHz
<input checked="" type="checkbox"/>	5725 ~ 5850	30 dBm /500 kHz

3.3.2 Test Procedures

For 5150 ~ 5250 MHz / 5250 ~ 5350 MHz / 5470 ~ 5725 MHz

Duty cycle \geq 98 %

1. Set RBW = 1 MHz, VBW = 3 MHz, Sweep time = auto, Detector = RMS.
2. Trace average 100 traces.
3. Use the peak marker function to determine the maximum amplitude level.

Duty cycle $<$ 98 %

1. Set RBW = 1 MHz, VBW = 3 MHz, Detector = RMS.
2. Set sweep time $\geq 10 * (\text{number of points in sweep}) * (\text{total on/off period of the transmitted signal})$.
3. Perform a single sweep.
4. Use the peak marker function to determine the maximum amplitude level.
5. Add $10 \log(1/x)$, where x is the duty cycle.

For 5725 ~ 5850 MHz

Duty cycle \geq 98 %

1. Set RBW = 500 kHz, VBW = 3 MHz, Sweep time = auto, Detector = RMS.
2. Trace average 100 traces.
3. Use the peak marker function to determine the maximum amplitude level.

Duty cycle $<$ 98 %

1. Set RBW = 500 kHz, VBW = 3 MHz, Detector = RMS.
2. Set sweep time $\geq 10 * (\text{number of points in sweep}) * (\text{total on/off period of the transmitted signal})$.
3. Perform a single sweep.
4. Use the peak marker function to determine the maximum amplitude level.
5. Add $10 \log(1/x)$, where x is the duty cycle.

3.3.3 Test Setup

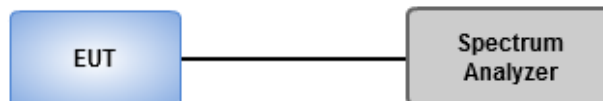

3.3.4 Test Results

Ambient Condition	22-23°C / 65-67%	Tested By	Akun Chung
--------------------------	------------------	------------------	------------

Refer to Appendix C.

3.4 Unwanted Emissions

3.4.1 Limit of Unwanted Emissions

Restricted Band Emissions Limit			
Frequency Range (MHz)	Field Strength (uV/m)	Field Strength (dBuV/m)	Measure Distance (m)
0.009~0.490	2400/F(kHz)	48.5 - 13.8	300
0.490~1.705	24000/F(kHz)	33.8 - 23	30
1.705~30.0	30	29	30
30~88	100	40	3
88~216	150	43.5	3
216~960	200	46	3
Above 960	500	54	3

Note 1:
Qusai-Peak value is measured for frequency below 1GHz except for 9–90 kHz, 110–490 kHz frequency band. Peak and average value are measured for frequency above 1GHz. The limit on average radio frequency emission is as above table. The limit on peak radio frequency emissions is 20 dB above the maximum permitted average emission limit

Note 2:
Measurements may be performed at a distance other than what is specified provided. When performing measurements at a distance other than that specified, the results shall be extrapolated to the specified distance using an extrapolation factor as below, Frequency at or above 30 MHz: 20 dB/decade Frequency below 30 MHz: 40 dB/decade.

Un-restricted band emissions above 1GHz Limit	
Operating Band	Limit
5.15 - 5.25 GHz	e.i.r.p. -27 dBm [68.2 dBuV/m@3m]
5.25 - 5.35 GHz	e.i.r.p. -27 dBm [68.2 dBuV/m@3m]
5.47 - 5.725 GHz	e.i.r.p. -27 dBm [68.2 dBuV/m@3m]
5.725 - 5.850 GHz	All emissions shall be limited to a level of -27 dBm/MHz at 75 MHz or more above or below the band edge increasing linearly to 10 dBm/MHz at 25 MHz above or below the band edge, and from 25 MHz above or below the band edge increasing linearly to a level of 15.6 dBm/MHz at 5 MHz above or below the band edge, and from 5 MHz above or below the band edge increasing linearly to a level of 27 dBm/MHz at the band edge.

Note 1: Measurements may be performed at a distance other than the limit distance provided they are not performed in the near field and the emissions to be measured can be detected by the measurement equipment. When performing measurements at a distance other than that specified, the results shall be extrapolated to the specified distance using an extrapolation factor of 20 dB/decade (inverse of linear distance for field-strength measurements, inverse of linear distance-squared for power-density measurements).

3.4.2 Test Procedures

1. Measurement is made at a semi-anechoic chamber that incorporates a turntable allowing a EUT rotation of 360°. A continuously-rotating, remotely-controlled turntable is installed at the test site to support the EUT and facilitate determination of the direction of maximum radiation for each EUT emission frequency. The EUT is placed at test table. For emissions testing at or below 1 GHz, the table height is 80 cm above the reference ground plane. For emission measurements above 1 GHz, the table height is 1.5 m
2. Measurement is made with the antenna positioned in both the horizontal and vertical planes of polarization. The measurement antenna is varied in height (1m ~ 4m) above the reference ground plane to obtain the maximum signal strength. Distance between EUT and antenna is 3 m.
3. This investigation is performed with the EUT rotated 360°, the antenna height scanned between 1 m and 4 m, and the antenna rotated to repeat the measurements for both the horizontal and vertical antenna polarizations.

Note:

1. 120kHz measurement bandwidth of test receiver and Quasi-peak detector is for radiated emission below 1GHz.
2. RBW=1MHz, VBW=3MHz and Peak detector is for peak measured value of radiated emission above 1GHz.
3. RBW=1MHz, VBW=1/T and Peak detector is for average measured value of radiated emission above 1GHz.

3.4.3 Test Setup

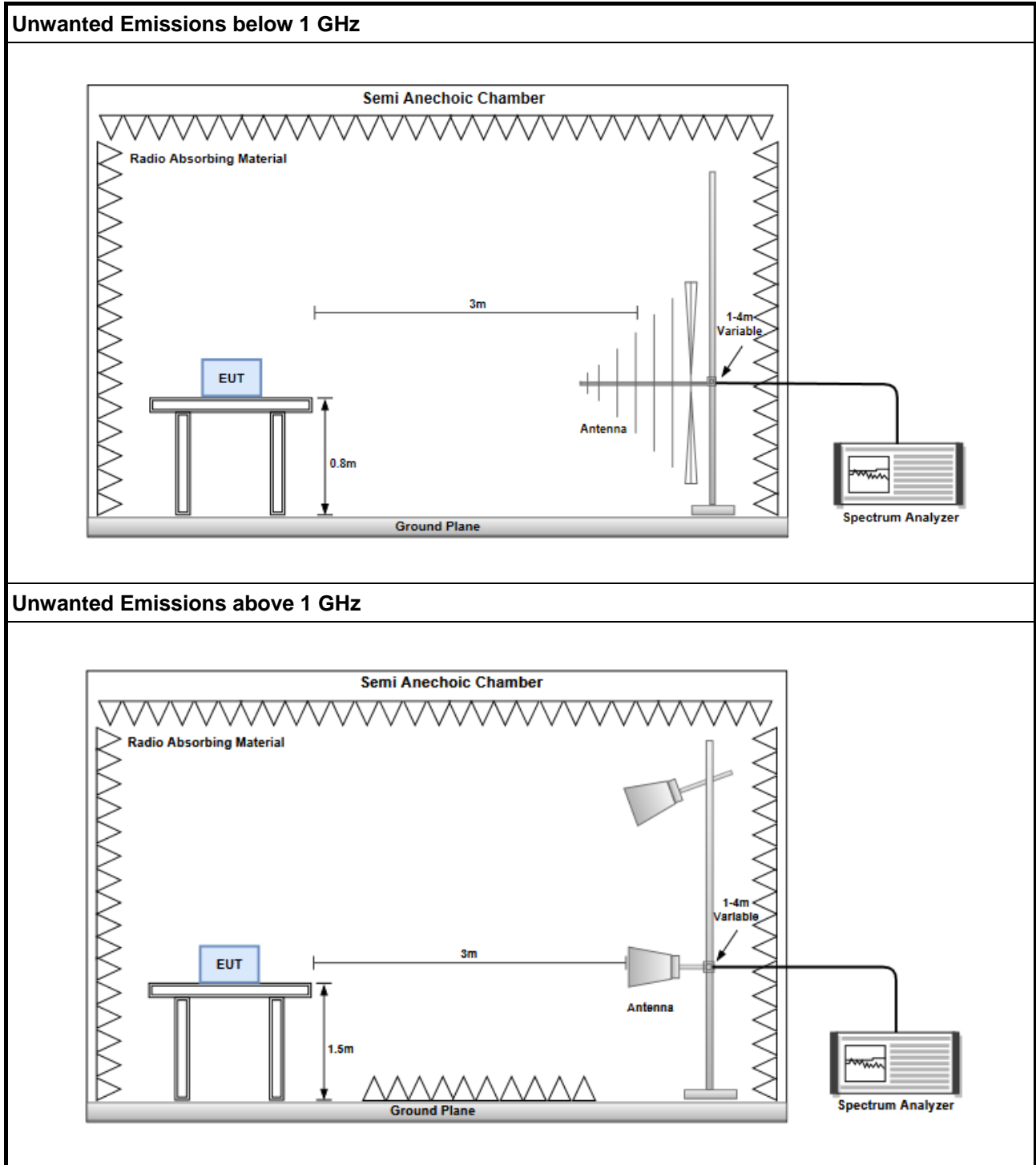

3.4.4 Test Results

Refer to Appendix D.

3.5 AC Power Line Conducted Emissions

3.5.1 Limit of AC Power Line Conducted Emissions

Conducted Emissions Limit		
Frequency Emission (MHz)	Quasi-Peak	Average
0.15-0.5	66 - 56 *	56 - 46 *
0.5-5	56	46
5-30	60	50

Note 1: * Decreases with the logarithm of the frequency.

3.5.2 Test Procedures

1. The device is placed on a test table, raised 80 cm above the reference ground plane. The vertical conducting plane is located 40 cm to the rear of the device.
2. The device is connected to line impedance stabilization network (LISN) and other accessories are connected to other LISN. Measured levels of AC power line conducted emission are across the 50 Ω LISN port.
3. AC conducted emission measurements is made over frequency range from 150 kHz to 30 MHz.
4. This measurement was performed with AC 120V/60Hz

3.5.3 Test Setup

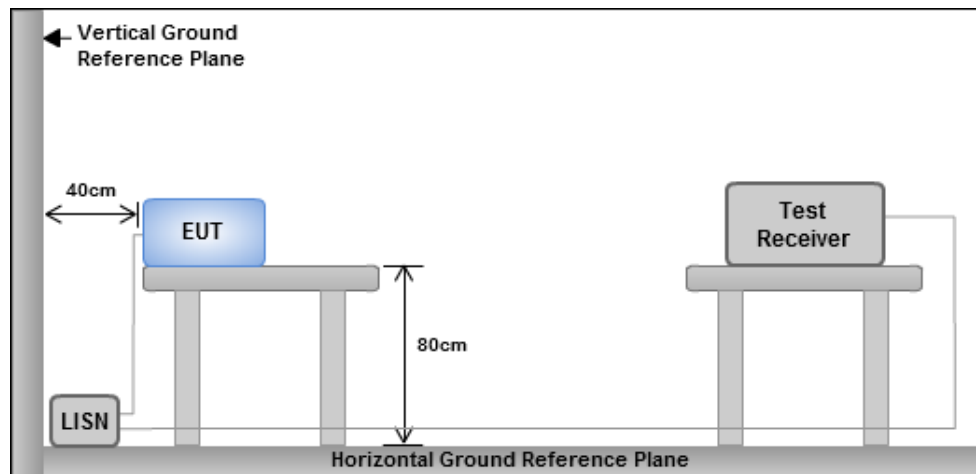

- Note: 1. Support units were connected to second LISN.
 2. Both of LISNs (AMN) are 80 cm from EUT and at least 80 cm from other units and other metal planes

3.5.4 Test Results

Refer to Appendix E.

4 Test laboratory information

Established in 2012, ICC provides foremost EMC & RF Testing and advisory consultation services by our skilled engineers and technicians. Our services employ a wide variety of advanced edge test equipment and one of the widest certification extents in the business.

International Certification Corporation (EMC and Wireless Communication Laboratory), it is our definitive objective is to institute long term, trust-based associations with our clients. The expectation we set up with our clients is based on outstanding service, practical expertise and devotion to a certified value structure. Our passion is to grant our clients with best EMC / RF services by oriented knowledgeable and accommodating staff.

Our Test sites are located at Linkou District and Kwei Shan District. Location map can be found on our website <http://www.icertifi.com.tw>.

Linkou

Tel: 886-2-2601-1640

No.30-2, Ding Fwu Tsuen, Lin Kou
District, New Taipei City, Taiwan
(R.O.C.)

Kwei Shan

Tel: 886-3-271-8666

No.3-1, Lane 6, Wen San 3rd
St., Kwei Shan Dist., Tao Yuan
City 33381, Taiwan (R.O.C.)
No.2-1, Lane 6, Wen San 3rd
St., Kwei Shan Dist., Tao Yuan
City 33381, Taiwan (R.O.C.)

Kwei Shan Site II

Tel: 886-3-271-8640

No.14-1, Lane 19, Wen San 3rd
St., Kwei Shan Dist., Tao Yuan
City 33381, Taiwan (R.O.C.)

If you have any suggestion, please feel free to contact us as below information.

Tel: 886-3-271-8666

Fax: 886-3-318-0345

Email: ICC_Service@icertifi.com.tw

==END==



Summary

Mode	Max-N dB (Hz)	Max-OBW (Hz)	ITU-Code	Min-N dB (Hz)	Min-OBW (Hz)
5.15-5.25GHz	-	-	-	-	-
802.11ax HEW20_RU26_Index3_20MHz_Nss1,(MCS0)_2TX	18.018M	17.025M	17M0D1D	17.886M	16.761M
802.11ax HEW20_RU52_Index38_20MHz_Nss1,(MCS0)_2TX	18.216M	17.097M	17M1D1D	18.018M	16.883M
802.11ax HEW20_RU106_Index53_20MHz_Nss1,(MCS0)_2TX	21.252M	18.282M	18M3D1D	19.008M	18.05M
802.11ax HEW40_RU26_Index12_40MHz_Nss1,(MCS0)_2TX	18.612M	17.27M	17M3D1D	18.216M	17.083M
802.11ax HEW40_RU52_Index42_40MHz_Nss1,(MCS0)_2TX	19.404M	17.303M	17M3D1D	18.084M	17.146M
802.11ax HEW40_RU106_Index54_40MHz_Nss1,(MCS0)_2TX	24.684M	18.993M	19M0D1D	22.704M	18.586M
802.11ax HEW40_RU242_Index61_40MHz_Nss1,(MCS0)_2TX	39.336M	19.692M	19M7D1D	38.94M	19M
802.11ax HEW80_RU26_Index21_80MHz_Nss1,(MCS0)_2TX	18.48M	17.516M	17M5D1D	18.216M	17.284M
802.11ax HEW80_RU52_Index49_80MHz_Nss1,(MCS0)_2TX	23.496M	19.556M	19M6D1D	22.176M	19.39M
802.11ax HEW80_RU106_Index58_80MHz_Nss1,(MCS0)_2TX	39.336M	36.474M	36M5D1D	38.544M	36.35M
802.11ax HEW80_RU242_Index62_80MHz_Nss1,(MCS0)_2TX	45.936M	38.124M	38M1D1D	44.88M	37.201M
802.11ax HEW80_RU484_Index65_80MHz_Nss1,(MCS0)_2TX	80.52M	39.85M	39M9D1D	79.728M	38.264M
5.25-5.35GHz	-	-	-	-	-
802.11ax HEW20_RU26_Index3_20MHz_Nss1,(MCS0)_2TX	18.018M	16.991M	17M0D1D	17.886M	16.94M
802.11ax HEW20_RU52_Index38_20MHz_Nss1,(MCS0)_2TX	18.15M	17.095M	17M1D1D	18.084M	17.033M
802.11ax HEW20_RU106_Index53_20MHz_Nss1,(MCS0)_2TX	21.054M	18.341M	18M3D1D	20.526M	18.205M
802.11ax HEW40_RU26_Index12_40MHz_Nss1,(MCS0)_2TX	18.48M	17.267M	17M3D1D	18.084M	17.099M
802.11ax HEW40_RU52_Index42_40MHz_Nss1,(MCS0)_2TX	18.876M	17.3M	17M3D1D	18.216M	17.123M
802.11ax HEW40_RU106_Index54_40MHz_Nss1,(MCS0)_2TX	23.1M	18.996M	19M0D1D	22.44M	18.604M
802.11ax HEW40_RU242_Index61_40MHz_Nss1,(MCS0)_2TX	39.336M	19.846M	19M8D1D	39.072M	18.995M
802.11ax HEW80_RU26_Index21_80MHz_Nss1,(MCS0)_2TX	18.48M	17.505M	17M5D1D	18.216M	17.298M
802.11ax HEW80_RU52_Index49_80MHz_Nss1,(MCS0)_2TX	24.024M	19.914M	19M9D1D	22.704M	19.363M
802.11ax HEW80_RU106_Index58_80MHz_Nss1,(MCS0)_2TX	38.808M	36.457M	36M5D1D	38.808M	36.344M
802.11ax HEW80_RU242_Index62_80MHz_Nss1,(MCS0)_2TX	45.408M	37.989M	38M0D1D	43.296M	37.228M
802.11ax HEW80_RU484_Index65_80MHz_Nss1,(MCS0)_2TX	80.256M	39.957M	40M0D1D	79.728M	38.399M
5.47-5.725GHz	-	-	-	-	-
802.11ax HEW20_RU26_Index3_20MHz_Nss1,(MCS0)_2TX	18.084M	17.023M	17M0D1D	13.995M	13.446M
802.11ax HEW20_RU52_Index38_20MHz_Nss1,(MCS0)_2TX	18.216M	17.092M	17M1D1D	14.025M	13.512M
802.11ax HEW20_RU106_Index53_20MHz_Nss1,(MCS0)_2TX	21.12M	18.367M	18M4D1D	16.65M	14.632M
802.11ax HEW40_RU26_Index12_40MHz_Nss1,(MCS0)_2TX	18.744M	17.28M	17M3D1D	13.93M	13.559M
802.11ax HEW40_RU52_Index42_40MHz_Nss1,(MCS0)_2TX	19.932M	17.313M	17M3D1D	14.525M	13.588M
802.11ax HEW40_RU106_Index54_40MHz_Nss1,(MCS0)_2TX	23.76M	19.017M	19M0D1D	22.176M	18.492M
802.11ax HEW40_RU242_Index61_40MHz_Nss1,(MCS0)_2TX	39.468M	19.523M	19M5D1D	22.82M	18.89M
802.11ax HEW80_RU26_Index21_80MHz_Nss1,(MCS0)_2TX	18.744M	17.518M	17M5D1D	17.952M	17.258M
802.11ax HEW80_RU52_Index49_80MHz_Nss1,(MCS0)_2TX	23.232M	19.864M	19M9D1D	17.775M	15.808M
802.11ax HEW80_RU106_Index58_80MHz_Nss1,(MCS0)_2TX	39.072M	36.449M	36M4D1D	34.575M	33M
802.11ax HEW80_RU242_Index62_80MHz_Nss1,(MCS0)_2TX	78.144M	38.097M	38M1D1D	44.616M	37.198M
802.11ax HEW80_RU484_Index65_80MHz_Nss1,(MCS0)_2TX	80.256M	39.965M	40M0D1D	74.85M	37.844M
5.725-5.85GHz	-	-	-	-	-
802.11ax HEW20_RU26_Index3_20MHz_Nss1,(MCS0)_2TX	3.74M	17.02M	17M0D1D	2.046M	3.843M
802.11ax HEW20_RU52_Index38_20MHz_Nss1,(MCS0)_2TX	15.114M	17.077M	17M1D1D	3.1M	3.97M



Mode	Max-N dB (Hz)	Max-OBW (Hz)	ITU-Code	Min-N dB (Hz)	Min-OBW (Hz)
802.11ax HEW20_RU106_Index53_20MHz_Nss1,(MCS0)_2TX	17.16M	18.4M	18M4D1D	3.48M	4.151M
802.11ax HEW40_RU26_Index12_40MHz_Nss1,(MCS0)_2TX	3.22M	17.301M	17M3D1D	2.112M	3.82M
802.11ax HEW40_RU52_Index42_40MHz_Nss1,(MCS0)_2TX	15.048M	17.281M	17M3D1D	3.36M	3.861M
802.11ax HEW40_RU106_Index54_40MHz_Nss1,(MCS0)_2TX	17.556M	32.165M	32M2D1D	4.44M	18.593M
802.11ax HEW40_RU242_Index61_40MHz_Nss1,(MCS0)_2TX	18.876M	31.348M	31M3D1D	4.34M	19.086M
802.11ax HEW80_RU26_Index21_80MHz_Nss1,(MCS0)_2TX	3.92M	39.549M	39M5D1D	2.112M	17.297M
802.11ax HEW80_RU52_Index49_80MHz_Nss1,(MCS0)_2TX	17.424M	19.839M	19M8D1D	2.54M	3.879M
802.11ax HEW80_RU106_Index58_80MHz_Nss1,(MCS0)_2TX	35.112M	36.471M	36M5D1D	3.5M	3.879M
802.11ax HEW80_RU242_Index62_80MHz_Nss1,(MCS0)_2TX	36.432M	39.099M	39M1D1D	4.26M	37.15M
802.11ax HEW80_RU484_Index65_80MHz_Nss1,(MCS0)_2TX	37.752M	39.235M	39M2D1D	4.28M	35.031M

Max-N dB = Maximum 6dB down bandwidth for 5.725-5.85GHz band / Maximum 26dB down bandwidth for other band;

Max-OBW = Maximum 99% occupied bandwidth;

Min-N dB = Minimum 6dB down bandwidth for 5.725-5.85GHz band / Minimum 26dB down bandwidth for other band;

Min-OBW = Minimum 99% occupied bandwidth



Result

Mode	Result	Limit (Hz)	Port 1-N dB (Hz)	Port 1-OBW (Hz)	Port 2-N dB (Hz)	Port 2-OBW (Hz)
802.11ax HEW20_RU26_Index3_20MHz_Nss1,(MCS0)_2TX	-	-	-	-	-	-
5180MHz	Pass	Inf	17.886M	16.94M	17.952M	17.025M
5200MHz	Pass	Inf	18.018M	16.973M	17.952M	17.014M
5240MHz	Pass	Inf	18.018M	16.892M	18.018M	16.761M
5260MHz	Pass	Inf	17.952M	16.94M	17.952M	16.985M
5300MHz	Pass	Inf	17.886M	16.954M	17.952M	16.99M
5320MHz	Pass	Inf	18.018M	16.955M	17.952M	16.991M
5500MHz	Pass	Inf	18.018M	16.957M	17.952M	17.023M
5580MHz	Pass	Inf	18.084M	16.957M	17.886M	16.977M
5700MHz	Pass	Inf	18.018M	16.962M	18.018M	16.985M
5720MHz Straddle 5.47-5.725GHz	Pass	Inf	14.01M	13.446M	13.995M	13.482M
5720MHz Straddle 5.725-5.85GHz	Pass	500k	3.22M	3.843M	3.74M	3.876M
5745MHz	Pass	500k	2.112M	16.967M	2.046M	16.981M
5785MHz	Pass	500k	2.046M	16.978M	2.046M	17.007M
5825MHz	Pass	500k	2.046M	16.972M	2.046M	17.02M
802.11ax HEW20_RU52_Index38_20MHz_Nss1,(MCS0)_2TX	-	-	-	-	-	-
5180MHz	Pass	Inf	18.15M	17.096M	18.15M	17.005M
5200MHz	Pass	Inf	18.216M	17.097M	18.084M	17.034M
5240MHz	Pass	Inf	18.15M	16.917M	18.018M	16.883M
5260MHz	Pass	Inf	18.15M	17.066M	18.15M	17.053M
5300MHz	Pass	Inf	18.15M	17.095M	18.084M	17.033M
5320MHz	Pass	Inf	18.15M	17.082M	18.15M	17.069M
5500MHz	Pass	Inf	18.216M	17.044M	17.952M	17.004M
5580MHz	Pass	Inf	18.018M	17.092M	18.084M	17.022M
5700MHz	Pass	Inf	18.084M	17.065M	18.084M	17.051M
5720MHz Straddle 5.47-5.725GHz	Pass	Inf	14.025M	13.512M	14.04M	13.556M
5720MHz Straddle 5.725-5.85GHz	Pass	500k	3.72M	3.97M	3.1M	4.984M
5745MHz	Pass	500k	15.048M	17.071M	15.048M	17.029M
5785MHz	Pass	500k	13.86M	17.07M	15.048M	17.06M
5825MHz	Pass	500k	15.114M	17.077M	13.728M	17.064M
802.11ax HEW20_RU106_Index53_20MHz_Nss1,(MCS0)_2TX	-	-	-	-	-	-
5180MHz	Pass	Inf	20.46M	18.282M	20.328M	18.19M
5200MHz	Pass	Inf	21.252M	18.28M	20.592M	18.174M
5240MHz	Pass	Inf	19.008M	18.088M	19.404M	18.05M
5260MHz	Pass	Inf	20.526M	18.285M	20.526M	18.209M
5300MHz	Pass	Inf	21.054M	18.295M	20.592M	18.205M
5320MHz	Pass	Inf	20.922M	18.341M	20.856M	18.269M
5500MHz	Pass	Inf	20.526M	18.367M	21.054M	18.262M
5580MHz	Pass	Inf	21.054M	18.337M	20.922M	18.285M



Mode	Result	Limit (Hz)	Port 1-N dB (Hz)	Port 1-OBW (Hz)	Port 2-N dB (Hz)	Port 2-OBW (Hz)
5700MHz	Pass	Inf	21.12M	18.357M	20.526M	18.252M
5720MHz Straddle 5.47-5.725GHz	Pass	Inf	20.16M	14.696M	16.65M	14.632M
5720MHz Straddle 5.725-5.85GHz	Pass	500k	3.5M	4.162M	3.48M	4.151M
5745MHz	Pass	500k	17.094M	18.4M	17.16M	18.252M
5785MHz	Pass	500k	17.16M	18.297M	17.16M	18.213M
5825MHz	Pass	500k	17.16M	18.295M	17.16M	18.23M
802.11ax HEW40_RU26_Index12_40MHz_Nss1,(MCS0)_2TX	-	-	-	-	-	-
5190MHz	Pass	Inf	18.48M	17.237M	18.216M	17.103M
5230MHz	Pass	Inf	18.612M	17.27M	18.216M	17.083M
5270MHz	Pass	Inf	18.48M	17.262M	18.216M	17.099M
5310MHz	Pass	Inf	18.48M	17.267M	18.084M	17.104M
5510MHz	Pass	Inf	18.48M	17.261M	18.084M	17.068M
5590MHz	Pass	Inf	18.612M	17.28M	18.216M	17.065M
5670MHz	Pass	Inf	18.744M	17.258M	18.084M	17.114M
5710MHz Straddle 5.47-5.725GHz	Pass	Inf	14.105M	13.655M	13.93M	13.559M
5710MHz Straddle 5.725-5.85GHz	Pass	500k	3.22M	3.82M	2.78M	3.837M
5755MHz	Pass	500k	2.112M	17.245M	2.112M	17.067M
5795MHz	Pass	500k	2.112M	17.301M	2.112M	17.096M
802.11ax HEW40_RU52_Index42_40MHz_Nss1,(MCS0)_2TX	-	-	-	-	-	-
5190MHz	Pass	Inf	19.404M	17.281M	18.216M	17.167M
5230MHz	Pass	Inf	19.404M	17.303M	18.084M	17.146M
5270MHz	Pass	Inf	18.48M	17.297M	18.216M	17.123M
5310MHz	Pass	Inf	18.876M	17.3M	18.48M	17.144M
5510MHz	Pass	Inf	19.272M	17.294M	18.48M	17.167M
5590MHz	Pass	Inf	19.404M	17.27M	18.084M	17.166M
5670MHz	Pass	Inf	19.932M	17.313M	18.216M	17.142M
5710MHz Straddle 5.47-5.725GHz	Pass	Inf	16.52M	13.779M	14.525M	13.588M
5710MHz Straddle 5.725-5.85GHz	Pass	500k	3.36M	3.861M	3.38M	3.873M
5755MHz	Pass	500k	15.048M	17.268M	15.048M	17.113M
5795MHz	Pass	500k	15.048M	17.281M	15.048M	17.181M
802.11ax HEW40_RU106_Index54_40MHz_Nss1,(MCS0)_2TX	-	-	-	-	-	-
5190MHz	Pass	Inf	24.684M	18.99M	23.1M	18.586M
5230MHz	Pass	Inf	23.76M	18.993M	22.704M	18.595M
5270MHz	Pass	Inf	23.1M	18.959M	22.44M	18.644M
5310MHz	Pass	Inf	23.1M	18.996M	22.44M	18.604M
5510MHz	Pass	Inf	22.968M	18.991M	22.968M	18.599M
5590MHz	Pass	Inf	23.364M	18.975M	23.76M	18.622M
5670MHz	Pass	Inf	23.232M	19.017M	22.176M	18.601M
5710MHz Straddle 5.47-5.725GHz	Pass	Inf	22.89M	18.681M	23.485M	18.492M
5710MHz Straddle 5.725-5.85GHz	Pass	500k	4.5M	32.064M	4.44M	32.165M



Mode	Result	Limit (Hz)	Port 1-N dB (Hz)	Port 1-OBW (Hz)	Port 2-N dB (Hz)	Port 2-OBW (Hz)
5755MHz	Pass	500k	17.292M	18.975M	17.556M	18.593M
5795MHz	Pass	500k	17.292M	18.984M	17.292M	18.64M
802.11ax HEW40_RU242_Index61_40MHz_Nss1,(MCS0)_2TX	-	-	-	-	-	-
5190MHz	Pass	Inf	39.204M	19.692M	38.94M	19.03M
5230MHz	Pass	Inf	39.336M	19.322M	39.204M	19M
5270MHz	Pass	Inf	39.204M	19.846M	39.336M	18.995M
5310MHz	Pass	Inf	39.336M	19.43M	39.072M	19.005M
5510MHz	Pass	Inf	39.336M	19.358M	39.204M	19.01M
5590MHz	Pass	Inf	39.468M	19.523M	39.204M	19.11M
5670MHz	Pass	Inf	39.468M	19.269M	39.204M	18.985M
5710MHz Straddle 5.47-5.725GHz	Pass	Inf	34.09M	18.902M	22.82M	18.89M
5710MHz Straddle 5.725-5.85GHz	Pass	500k	4.38M	27.726M	4.34M	31.348M
5755MHz	Pass	500k	18.744M	19.836M	18.876M	19.086M
5795MHz	Pass	500k	18.876M	19.84M	18.876M	19.164M
802.11ax HEW80_RU26_Index21_80MHz_Nss1,(MCS0)_2TX	-	-	-	-	-	-
5210MHz	Pass	Inf	18.48M	17.516M	18.216M	17.284M
5290MHz	Pass	Inf	18.48M	17.505M	18.216M	17.298M
5530MHz	Pass	Inf	18.744M	17.518M	18.216M	17.259M
5610MHz	Pass	Inf	18.744M	17.47M	17.952M	17.312M
5690MHz Straddle 5.47-5.725GHz	Pass	Inf	18.675M	17.43M	18.225M	17.258M
5690MHz Straddle 5.725-5.85GHz	Pass	500k	3.92M	39.549M	3M	39.48M
5775MHz	Pass	500k	2.112M	17.485M	2.112M	17.297M
802.11ax HEW80_RU52_Index49_80MHz_Nss1,(MCS0)_2TX	-	-	-	-	-	-
5210MHz	Pass	Inf	23.496M	19.556M	22.176M	19.39M
5290MHz	Pass	Inf	24.024M	19.914M	22.704M	19.363M
5530MHz	Pass	Inf	23.232M	19.864M	22.704M	19.21M
5610MHz	Pass	Inf	22.968M	19.736M	22.176M	19.271M
5690MHz Straddle 5.47-5.725GHz	Pass	Inf	19.725M	16.215M	17.775M	15.808M
5690MHz Straddle 5.725-5.85GHz	Pass	500k	3.22M	3.918M	2.54M	3.879M
5775MHz	Pass	500k	17.16M	19.839M	17.424M	19.45M
802.11ax HEW80_RU106_Index58_80MHz_Nss1,(MCS0)_2TX	-	-	-	-	-	-
5210MHz	Pass	Inf	38.544M	36.474M	39.336M	36.35M
5290MHz	Pass	Inf	38.808M	36.457M	38.808M	36.344M
5530MHz	Pass	Inf	38.808M	36.449M	39.072M	36.364M
5610MHz	Pass	Inf	38.808M	36.437M	38.808M	36.31M
5690MHz Straddle 5.47-5.725GHz	Pass	Inf	34.8M	33.032M	34.575M	33M
5690MHz Straddle 5.725-5.85GHz	Pass	500k	3.5M	3.879M	3.5M	3.89M
5775MHz	Pass	500k	35.112M	36.471M	35.112M	36.386M
802.11ax HEW80_RU242_Index62_80MHz_Nss1,(MCS0)_2TX	-	-	-	-	-	-



Mode	Result	Limit (Hz)	Port 1-N dB (Hz)	Port 1-OBW (Hz)	Port 2-N dB (Hz)	Port 2-OBW (Hz)
5210MHz	Pass	Inf	45.936M	38.124M	44.88M	37.201M
5290MHz	Pass	Inf	45.408M	37.989M	43.296M	37.228M
5530MHz	Pass	Inf	57.288M	38.097M	44.616M	37.223M
5610MHz	Pass	Inf	78.144M	37.988M	44.616M	37.198M
5690MHz Straddle 5.47-5.725GHz	Pass	Inf	74.775M	37.706M	45.825M	37.395M
5690MHz Straddle 5.725-5.85GHz	Pass	500k	4.26M	37.15M	6.2M	39.099M
5775MHz	Pass	500k	36.432M	38.052M	36.432M	37.219M
802.11ax HEW80_RU484_Index65_80MHz_Nss1,(MCS0)_2TX	-	-	-	-	-	-
5210MHz	Pass	Inf	80.52M	39.85M	79.728M	38.264M
5290MHz	Pass	Inf	80.256M	39.957M	79.728M	38.399M
5530MHz	Pass	Inf	79.728M	39.965M	80.256M	38.37M
5610MHz	Pass	Inf	79.992M	39.746M	79.992M	38.475M
5690MHz Straddle 5.47-5.725GHz	Pass	Inf	74.925M	37.865M	74.85M	37.844M
5690MHz Straddle 5.725-5.85GHz	Pass	500k	4.28M	35.031M	4.44M	37.031M
5775MHz	Pass	500k	37.752M	39.235M	37.752M	38.396M

Port X-N dB = Port X 6dB down bandwidth for 5.725-5.85GHz band / 26dB down bandwidth for other band

Port X-OBW = Port X 99% occupied bandwidth

5.15-5.25GHz_802.11ax HEW20_RU26_Index3_20MHz_Nss1,(MCS0)_2TX

EBW

5180MHz

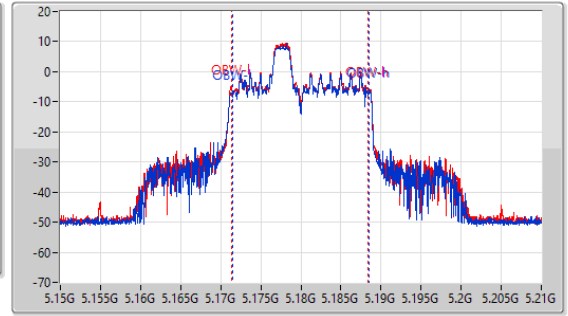
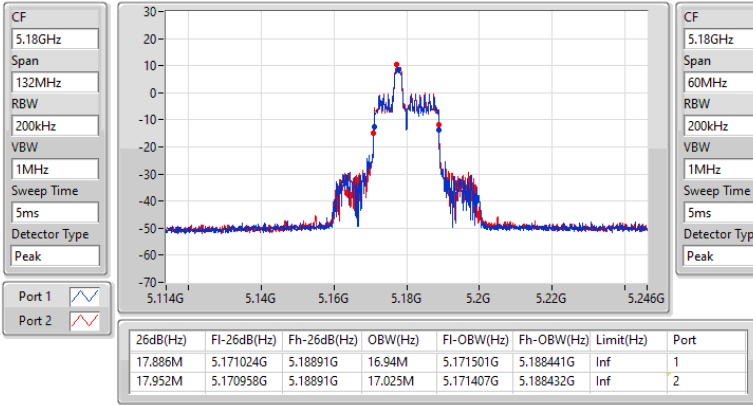

5.15-5.25GHz_802.11ax HEW20_RU26_Index3_20MHz_Nss1,(MCS0)_2TX

EBW

5200MHz

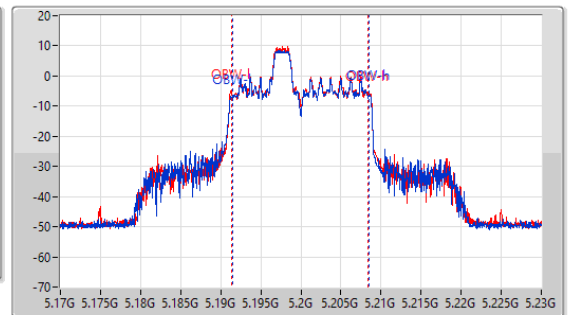
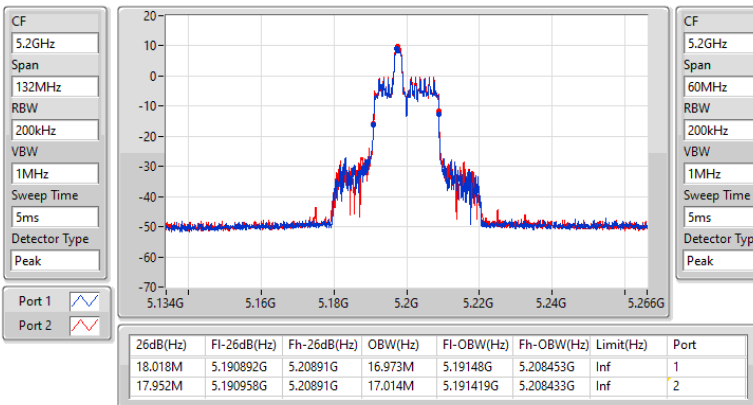

5.15-5.25GHz_802.11ax_HEW20_RU26_Index3_20MHz_Nss1,(MCS0)_2TX

EBW

5240MHz

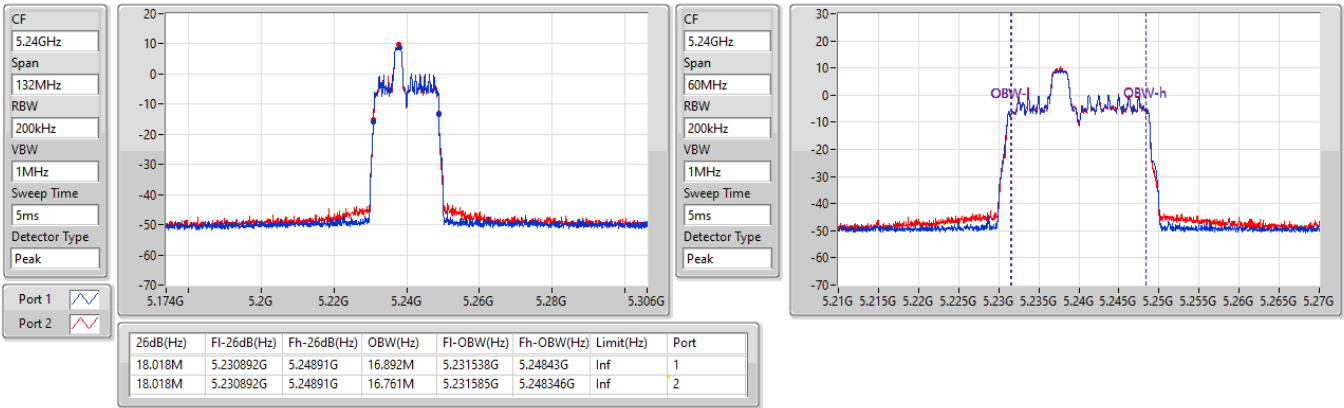

5.25-5.35GHz_802.11ax_HEW20_RU26_Index3_20MHz_Nss1,(MCS0)_2TX

EBW

5260MHz

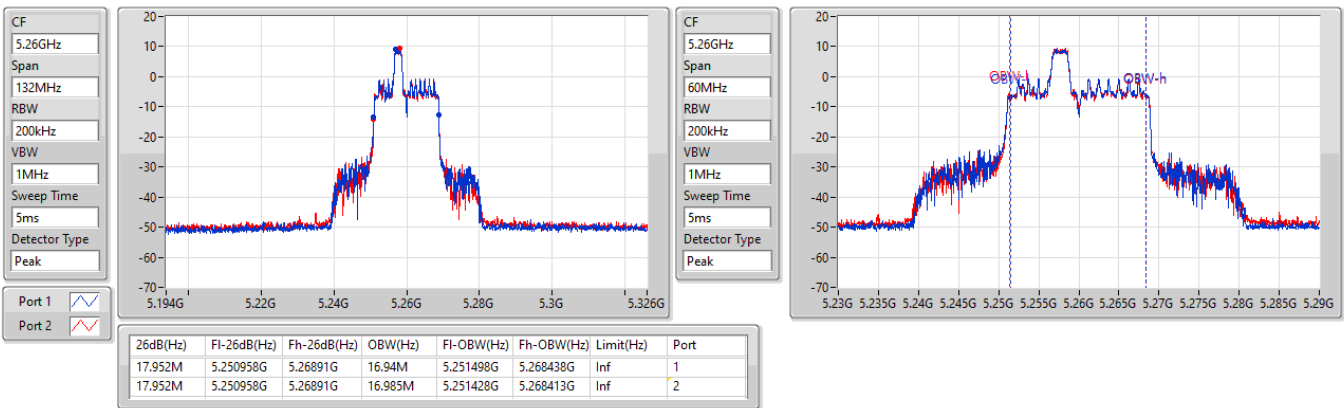

5.25-5.35GHz_802.11ax_HEW20_RU26_Index3_20MHz_Nss1,(MCS0)_2TX

EBW

5300MHz

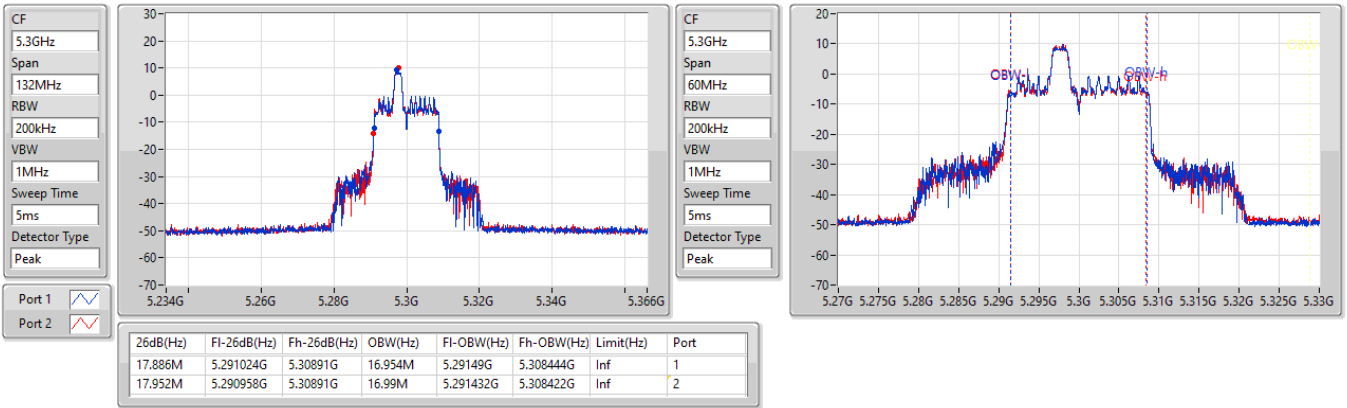

5.25-5.35GHz_802.11ax_HEW20_RU26_Index3_20MHz_Nss1,(MCS0)_2TX

EBW

5320MHz

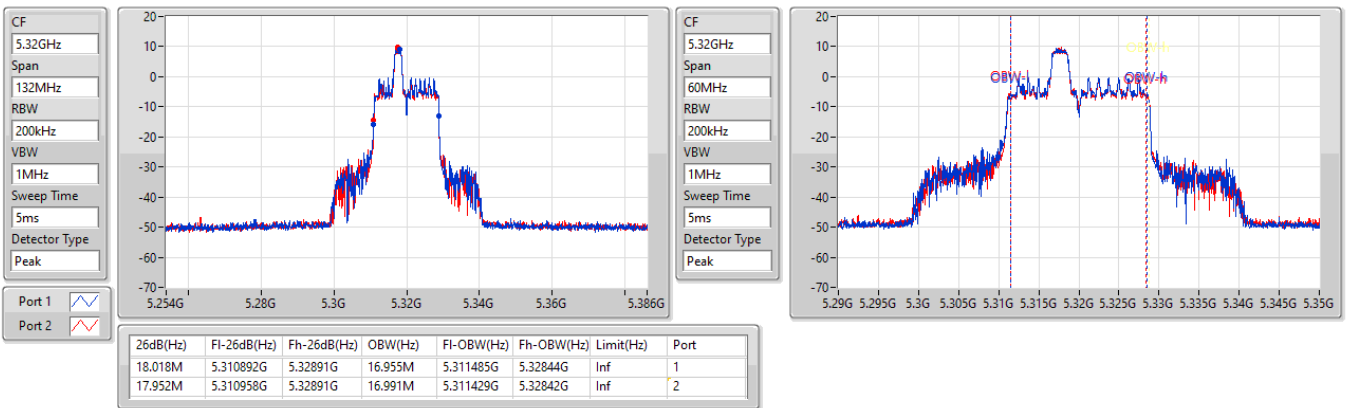

5.47-5.725GHz_802.11ax HEW20_RU26_Index3_20MHz_Nss1,(MCS0)_2TX

EBW

5500MHz

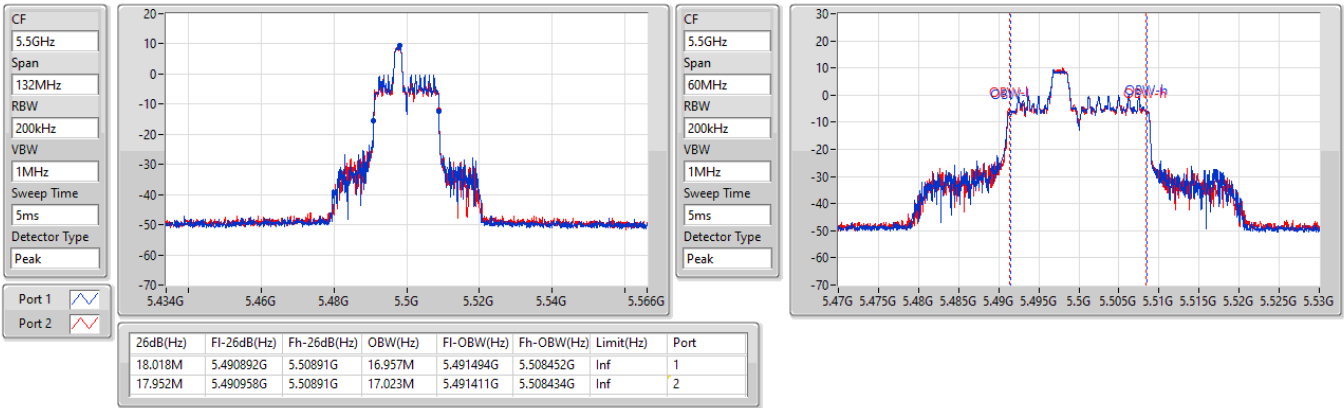

5.47-5.725GHz_802.11ax HEW20_RU26_Index3_20MHz_Nss1,(MCS0)_2TX

EBW

5580MHz

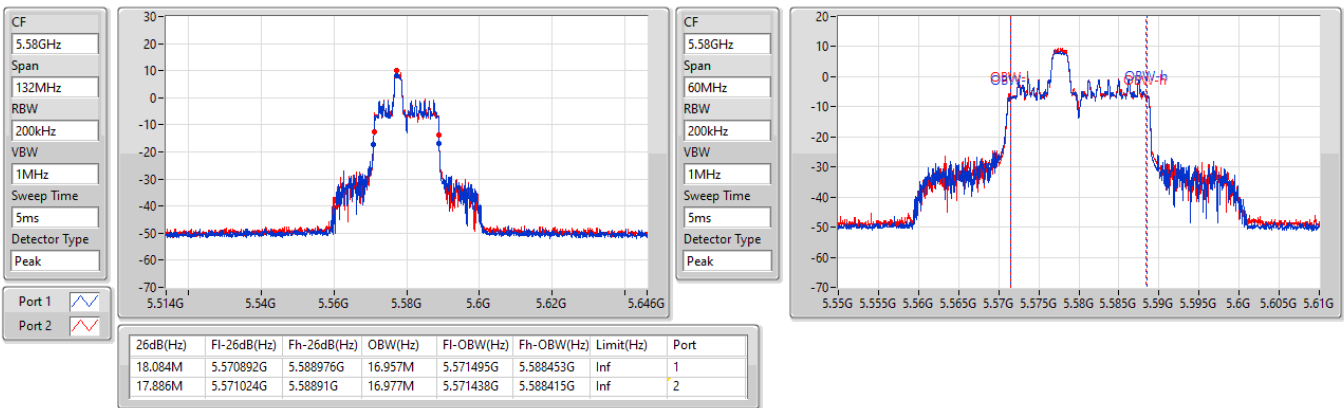

5.47-5.725GHz_802.11ax HEW20_RU26_Index3_20MHz_Nss1,(MCS0)_2TX

EBW

5700MHz

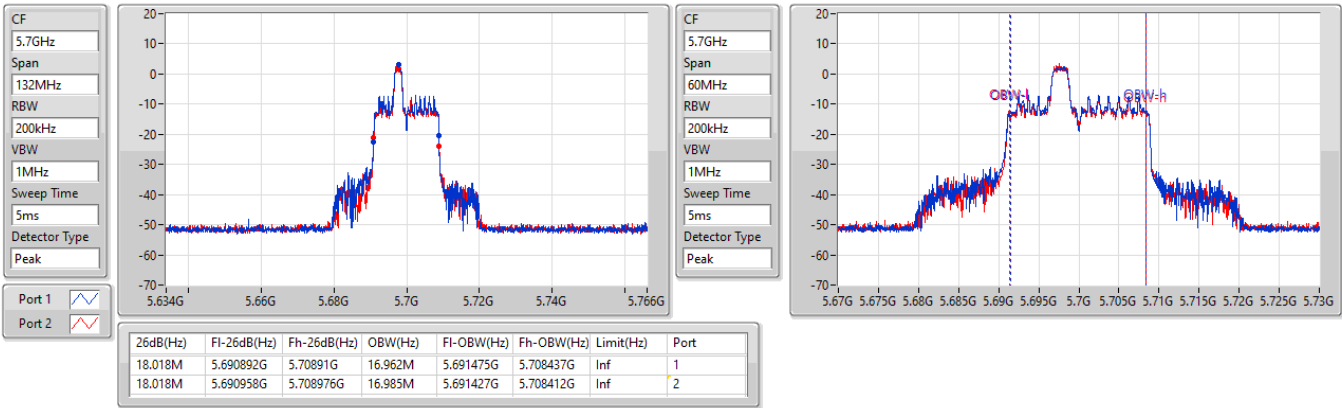

5.47-5.725GHz_802.11ax HEW20_RU26_Index3_20MHz_Nss1,(MCS0)_2TX

EBW

5720MHz Straddle 5.47-5.725GHz

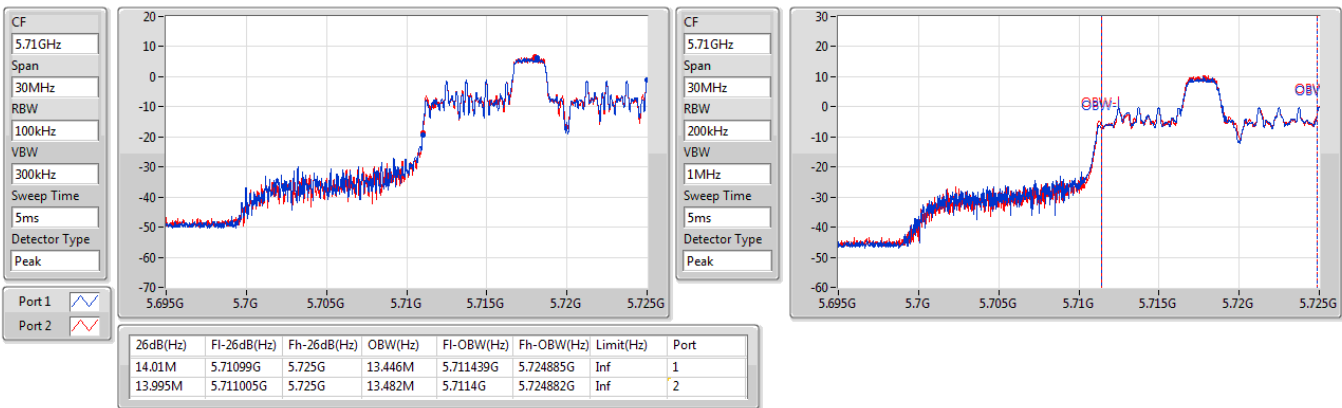



5.725-5.85GHz_802.11ax HEW20_RU26_Index3_20MHz_Nss1,(MCS0)_2TX

EBW

5720MHz Straddle 5.725-5.85GHz

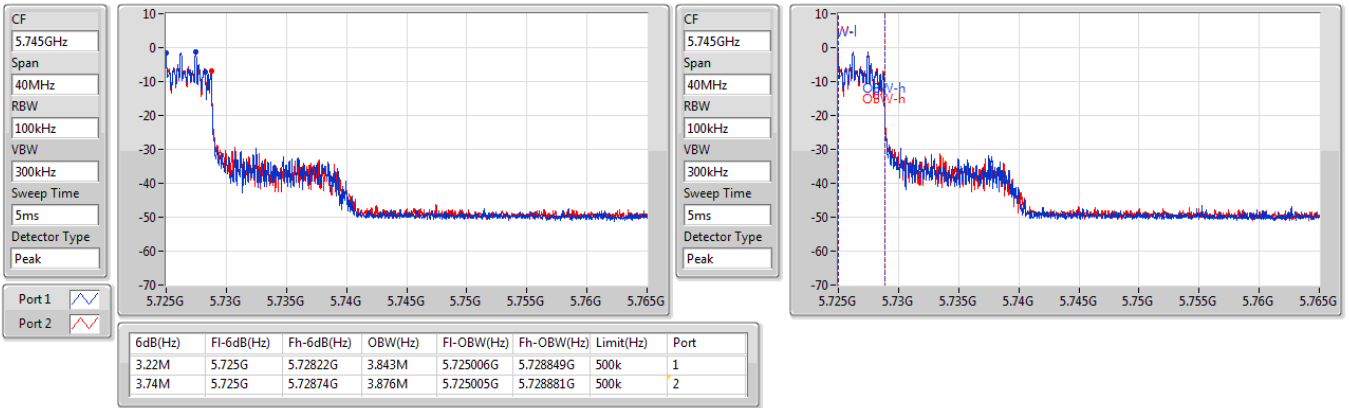

5.725-5.85GHz_802.11ax HEW20_RU26_Index3_20MHz_Nss1,(MCS0)_2TX

EBW

5720MHz Straddle 5.725-5.85GHz

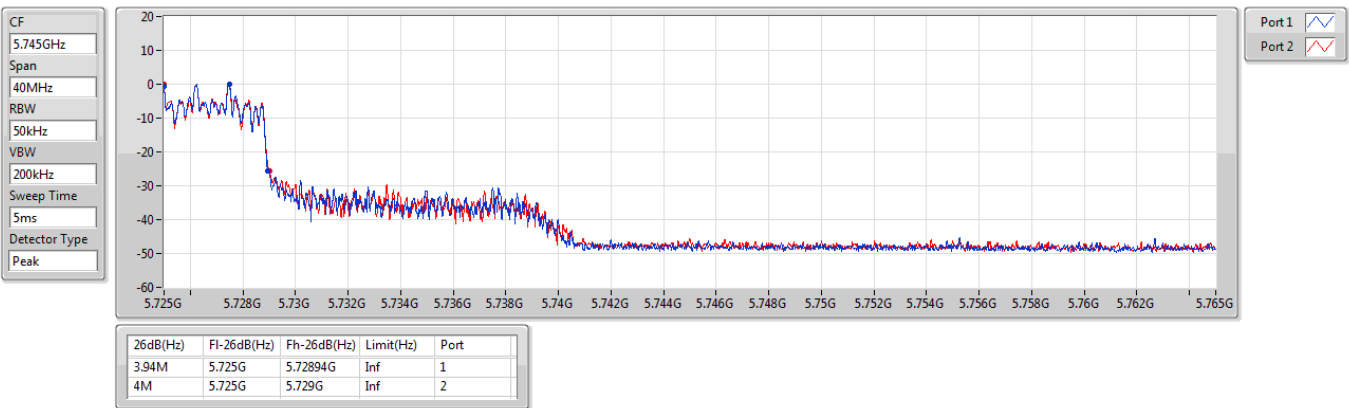



5.725-5.85GHz_802.11ax HEW20_RU26_Index3_20MHz_Nss1,(MCS0)_2TX

EBW

5745MHz

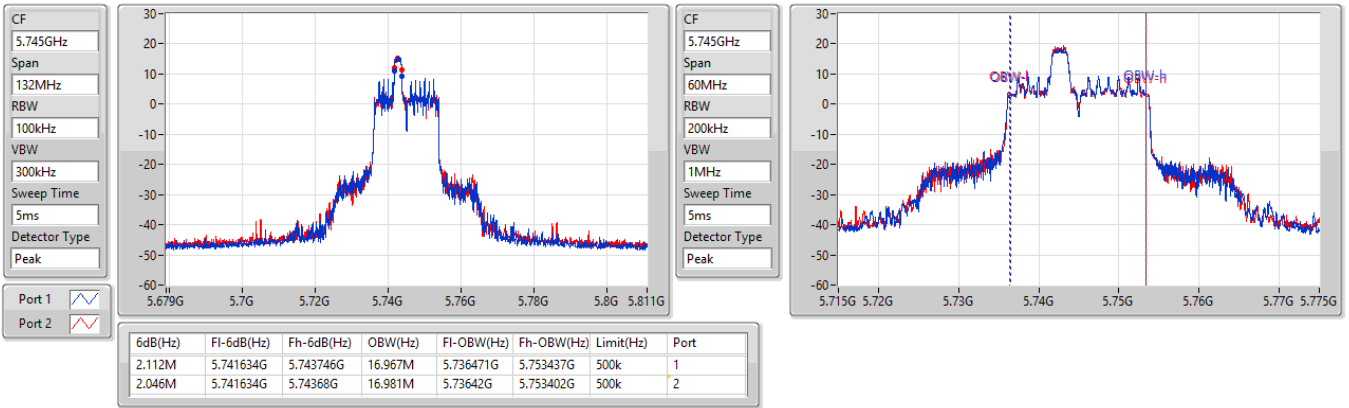

5.725-5.85GHz_802.11ax HEW20_RU26_Index3_20MHz_Nss1,(MCS0)_2TX

EBW

5745MHz

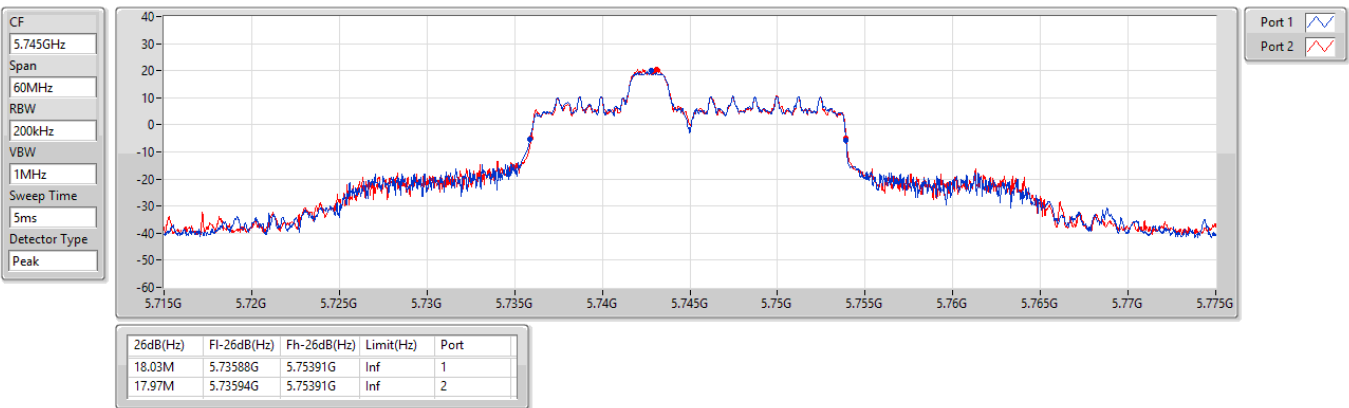



5.725-5.85GHz_802.11ax HEW20_RU26_Index3_20MHz_Nss1,(MCS0)_2TX

EBW

5785MHz

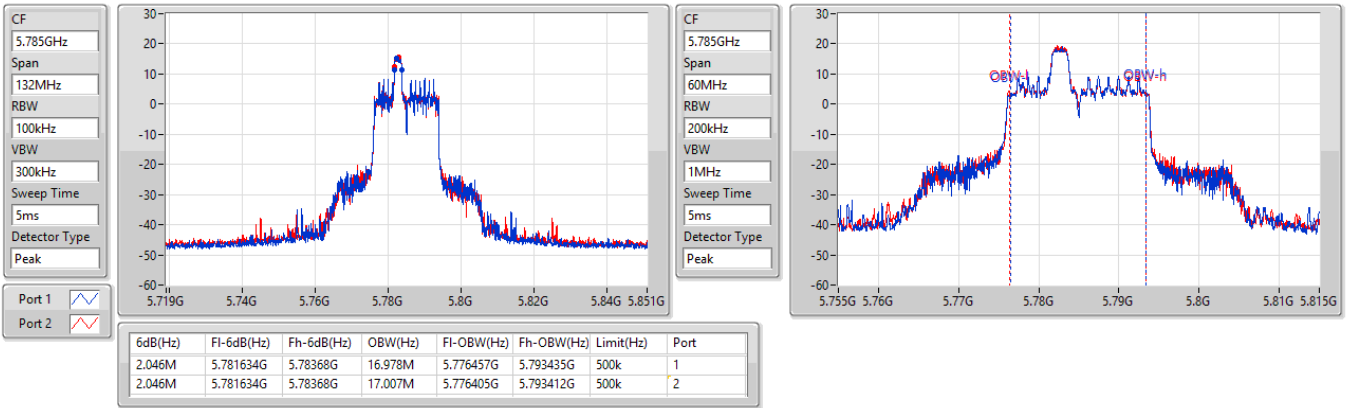

5.725-5.85GHz_802.11ax HEW20_RU26_Index3_20MHz_Nss1,(MCS0)_2TX

EBW

5785MHz

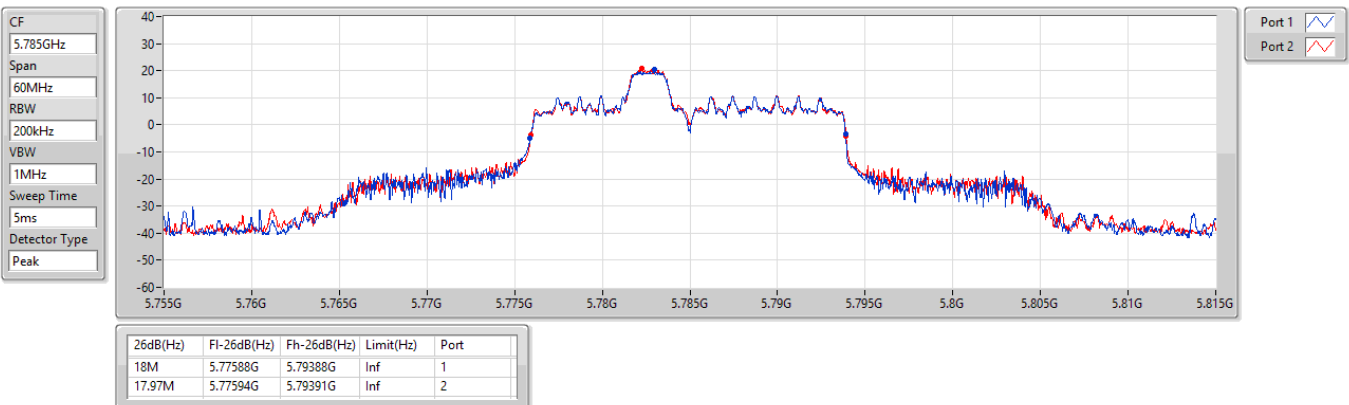



5.725-5.85GHz_802.11ax HEW20_RU26_Index3_20MHz_Nss1,(MCS0)_2TX

EBW

5825MHz

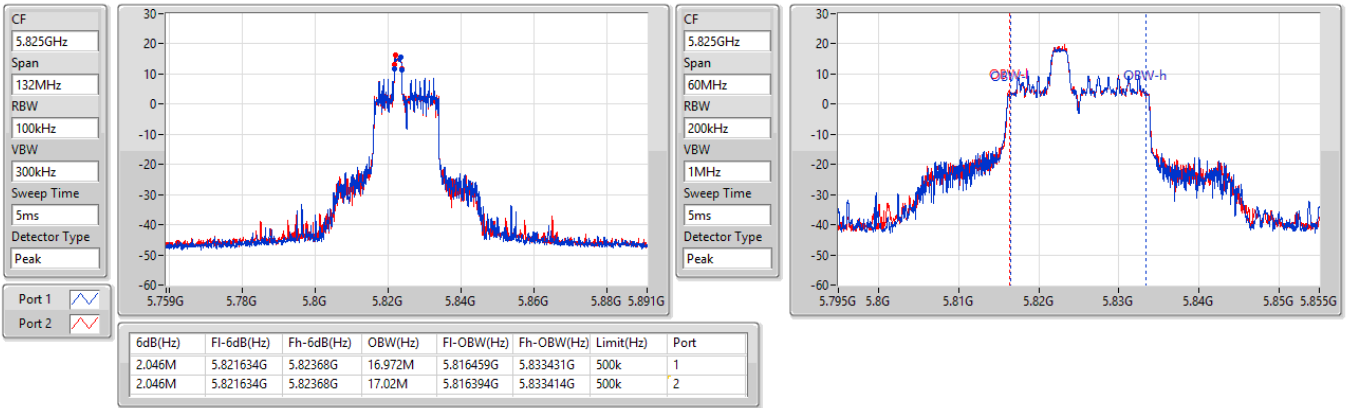

5.725-5.85GHz_802.11ax HEW20_RU26_Index3_20MHz_Nss1,(MCS0)_2TX

EBW

5825MHz

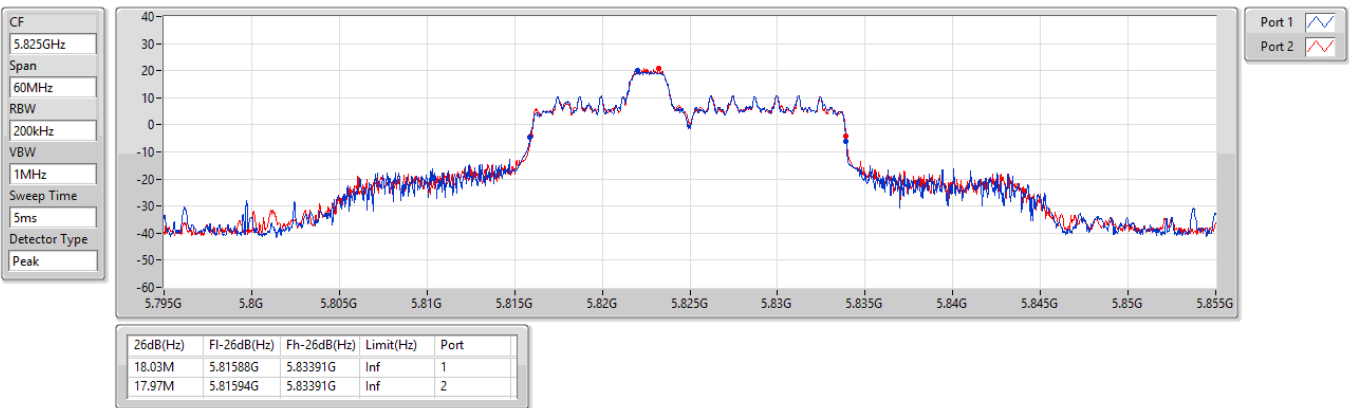

5.15-5.25GHz_802.11ax_HEW20_RU52_Index38_20MHz_Nss1,(MCS0)_2TX

EBW

5180MHz

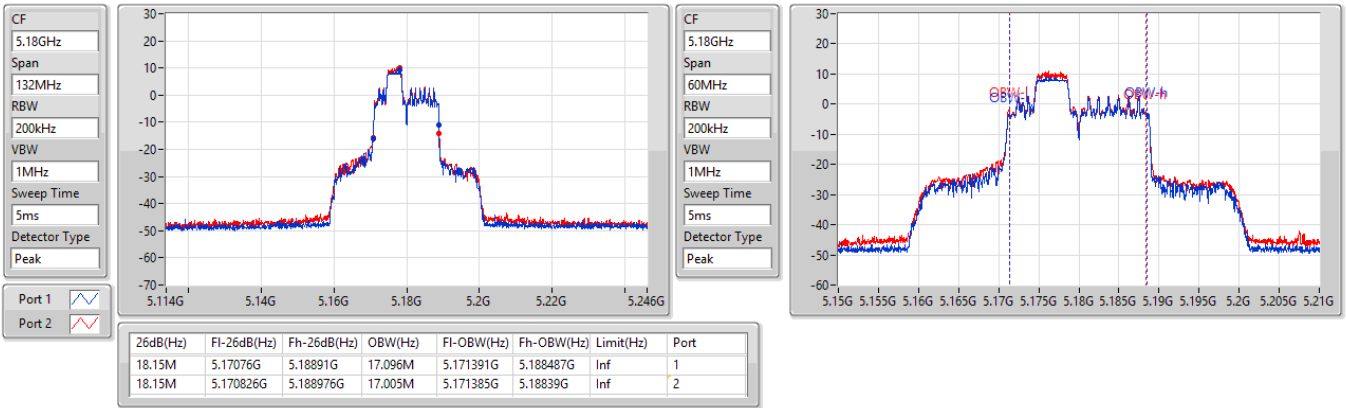

5.15-5.25GHz_802.11ax_HEW20_RU52_Index38_20MHz_Nss1,(MCS0)_2TX

EBW

5200MHz

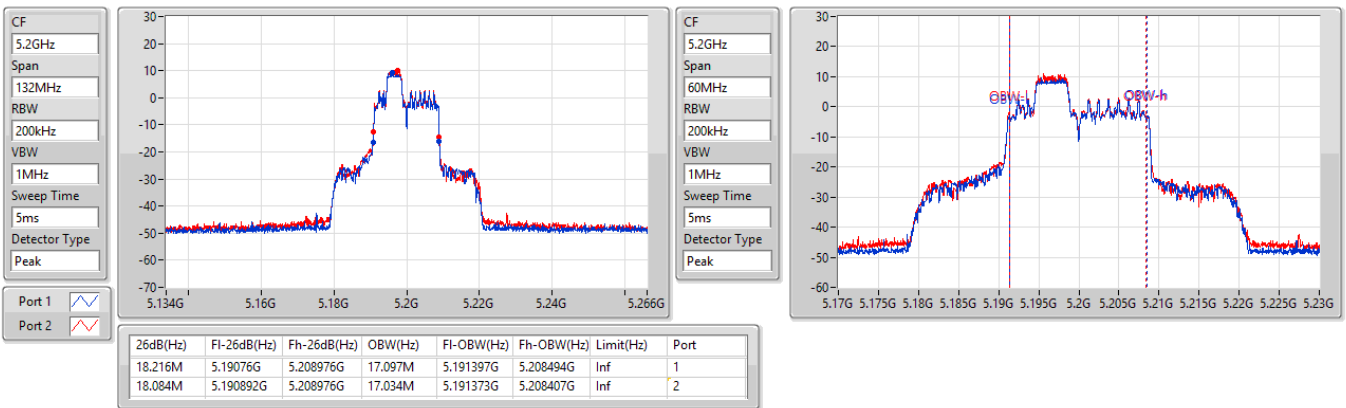

5.15-5.25GHz_802.11ax_HEW20_RU52_Index38_20MHz_Nss1,(MCS0)_2TX

EBW

5240MHz

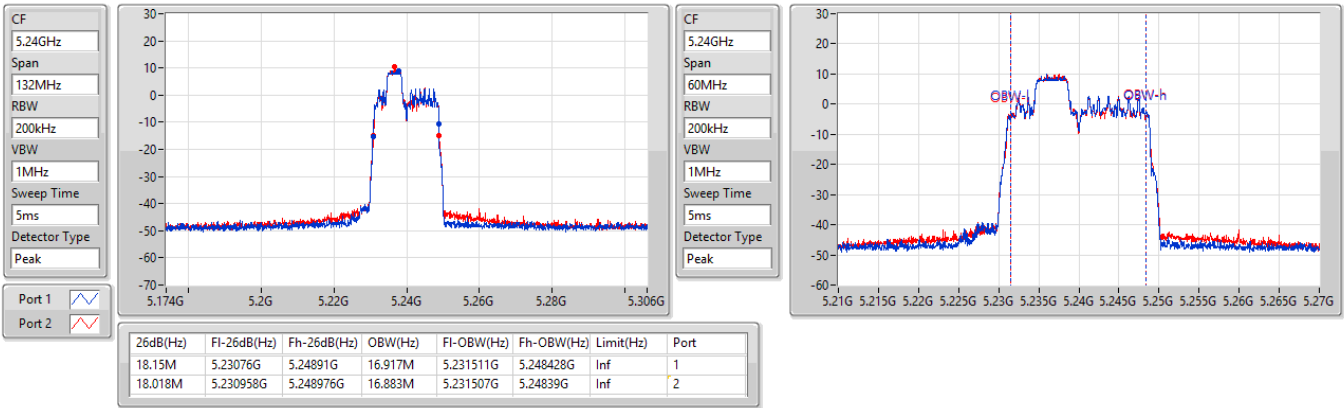

5.25-5.35GHz_802.11ax_HEW20_RU52_Index38_20MHz_Nss1,(MCS0)_2TX

EBW

5260MHz

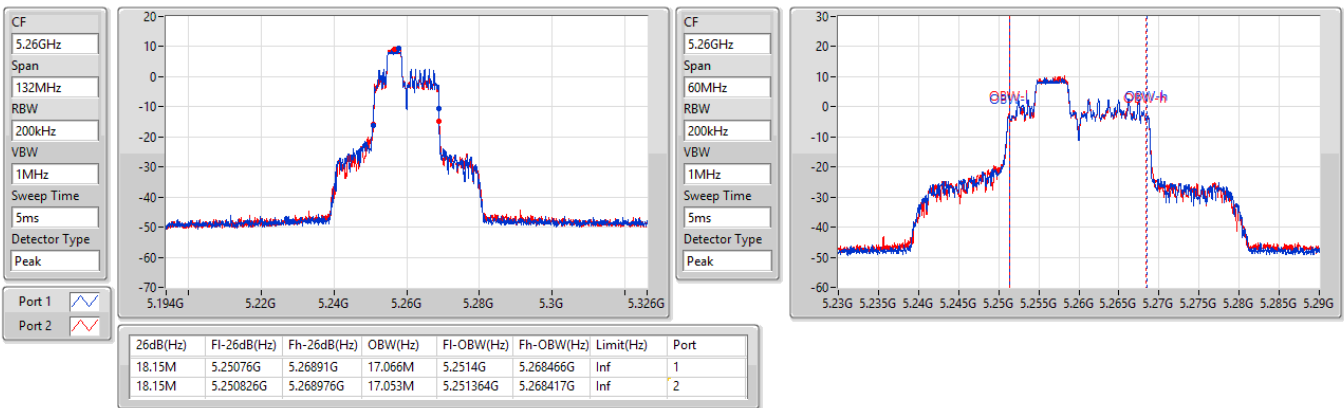

5.25-5.35GHz_802.11ax_HEW20_RU52_Index38_20MHz_Nss1,(MCS0)_2TX

EBW

5300MHz

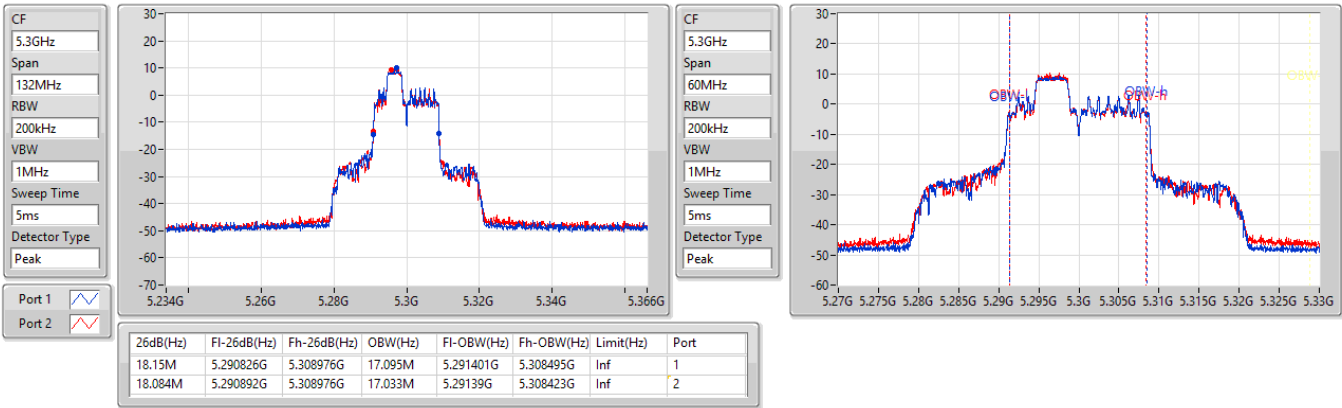

5.25-5.35GHz_802.11ax_HEW20_RU52_Index38_20MHz_Nss1,(MCS0)_2TX

EBW

5320MHz

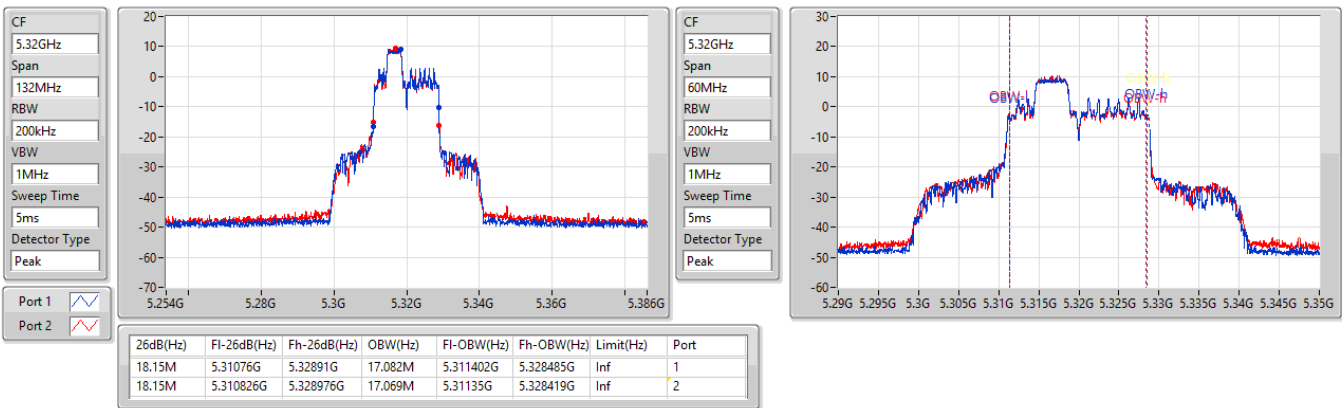

5.47-5.725GHz_802.11ax HEW20_RU52_Index38_20MHz_Nss1,(MCS0)_2TX

EBW

5500MHz

CF: 5.5GHz
 Span: 132MHz
 RBW: 200kHz
 VBW: 1MHz
 Sweep Time: 5ms
 Detector Type: Peak

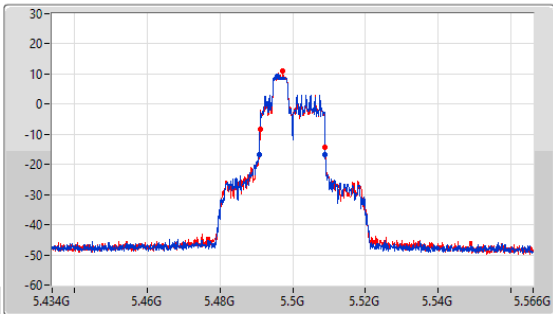

CF: 5.5GHz
 Span: 60MHz
 RBW: 200kHz
 VBW: 1MHz
 Sweep Time: 5ms
 Detector Type: Peak

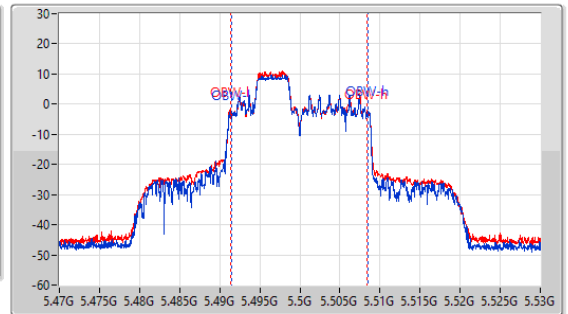

26dB(Hz)	Fl-26dB(Hz)	Fh-26dB(Hz)	OBW(Hz)	Fl-OBW(Hz)	Fh-OBW(Hz)	Limit(Hz)	Port
18.216M	5.49076G	5.508976G	17.044M	5.491439G	5.508483G	Inf	1
17.952M	5.491024G	5.508976G	17.004M	5.491382G	5.508387G	Inf	2

5.47-5.725GHz_802.11ax HEW20_RU52_Index38_20MHz_Nss1,(MCS0)_2TX

EBW

5580MHz

CF: 5.58GHz
 Span: 132MHz
 RBW: 200kHz
 VBW: 1MHz
 Sweep Time: 5ms
 Detector Type: Peak

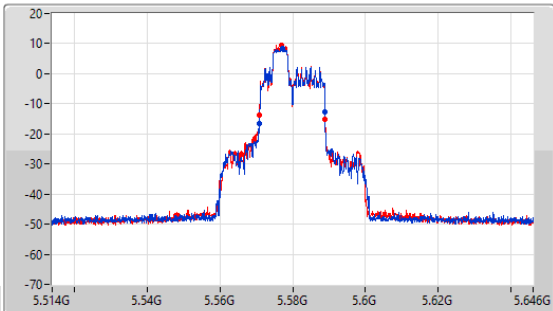

CF: 5.58GHz
 Span: 60MHz
 RBW: 200kHz
 VBW: 1MHz
 Sweep Time: 5ms
 Detector Type: Peak

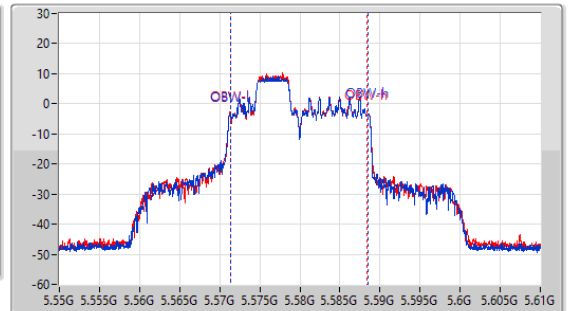

26dB(Hz)	Fl-26dB(Hz)	Fh-26dB(Hz)	OBW(Hz)	Fl-OBW(Hz)	Fh-OBW(Hz)	Limit(Hz)	Port
18.018M	5.570892G	5.58891G	17.092M	5.571398G	5.58849G	Inf	1
18.084M	5.570892G	5.588976G	17.022M	5.5714G	5.588422G	Inf	2

5.47-5.725GHz_802.11ax HEW20_RU52_Index38_20MHz_Nss1,(MCS0)_2TX

EBW

5700MHz

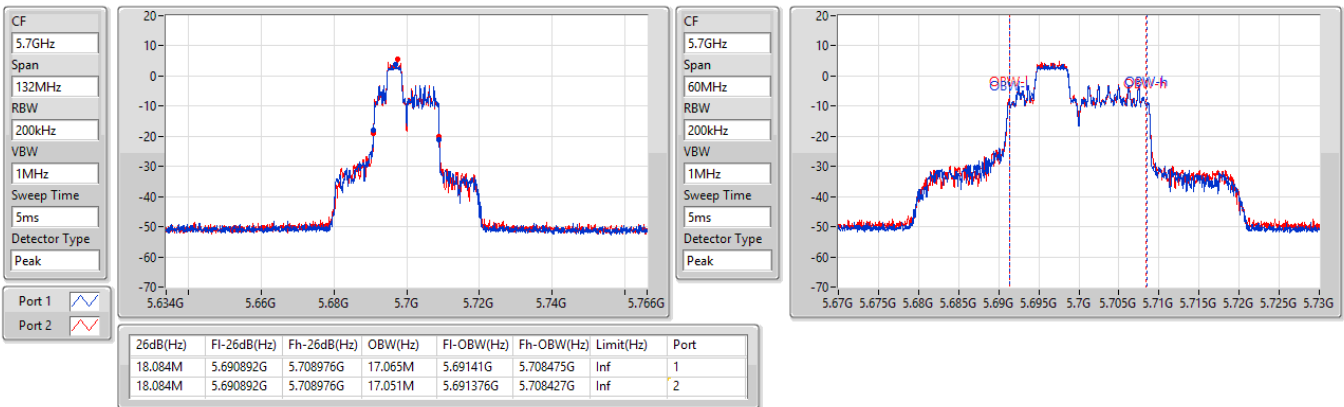

5.47-5.725GHz_802.11ax HEW20_RU52_Index38_20MHz_Nss1,(MCS0)_2TX

EBW

5720MHz Straddle 5.47-5.725GHz

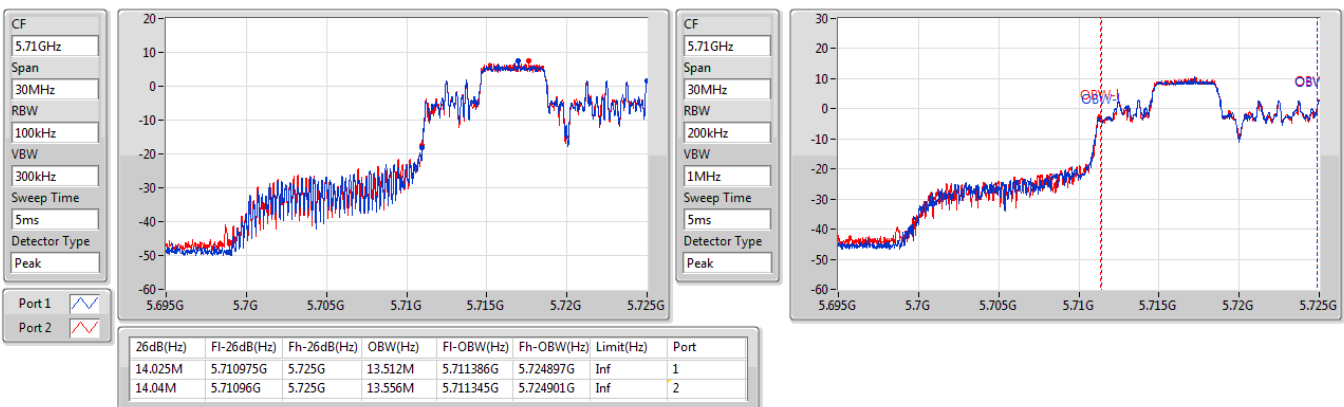



5.725-5.85GHz_802.11ax HEW20_RU52_Index38_20MHz_Nss1,(MCS0)_2TX

EBW

5720MHz Straddle 5.725-5.85GHz

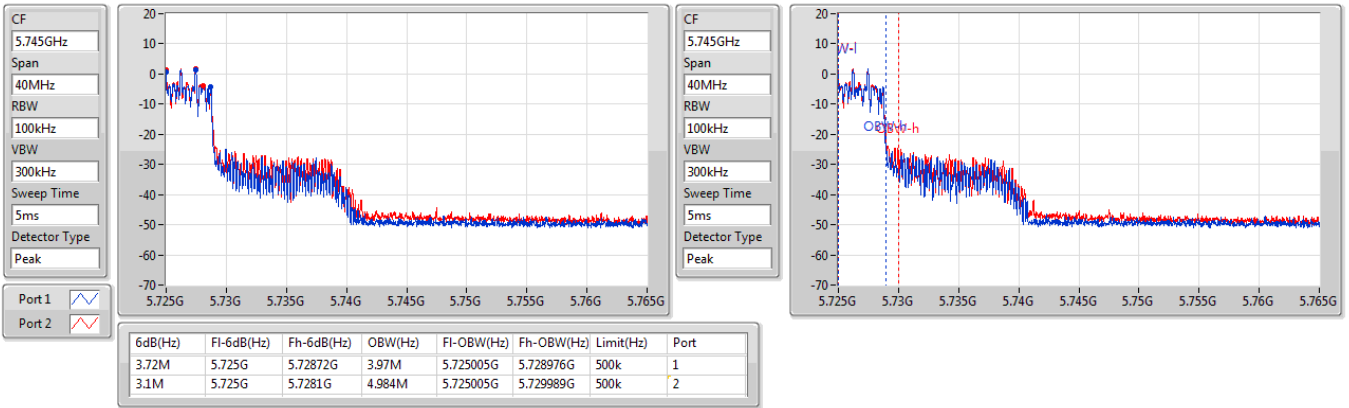

5.725-5.85GHz_802.11ax HEW20_RU52_Index38_20MHz_Nss1,(MCS0)_2TX

EBW

5720MHz Straddle 5.725-5.85GHz

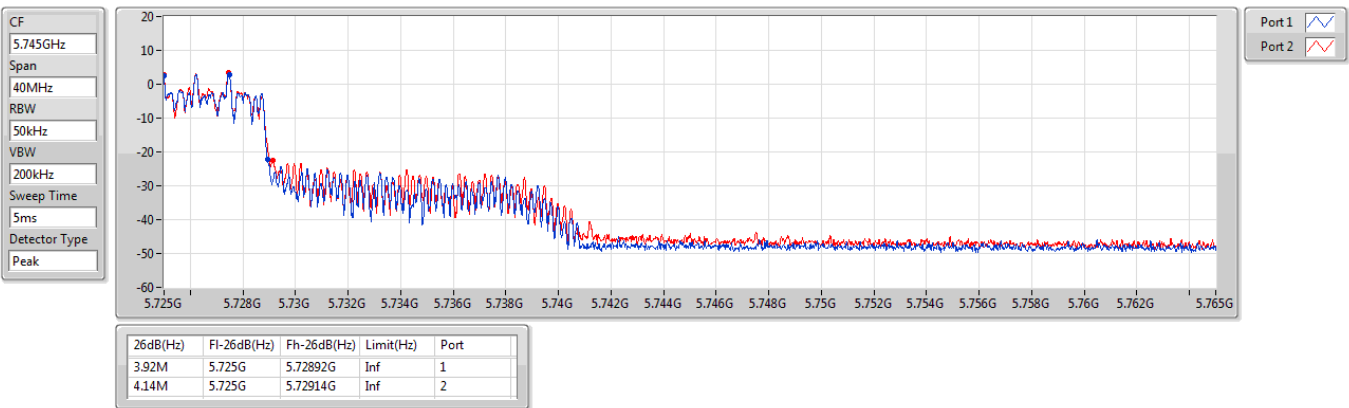



5.725-5.85GHz_802.11ax HEW20_RU52_Index38_20MHz_Nss1,(MCS0)_2TX

EBW

5745MHz

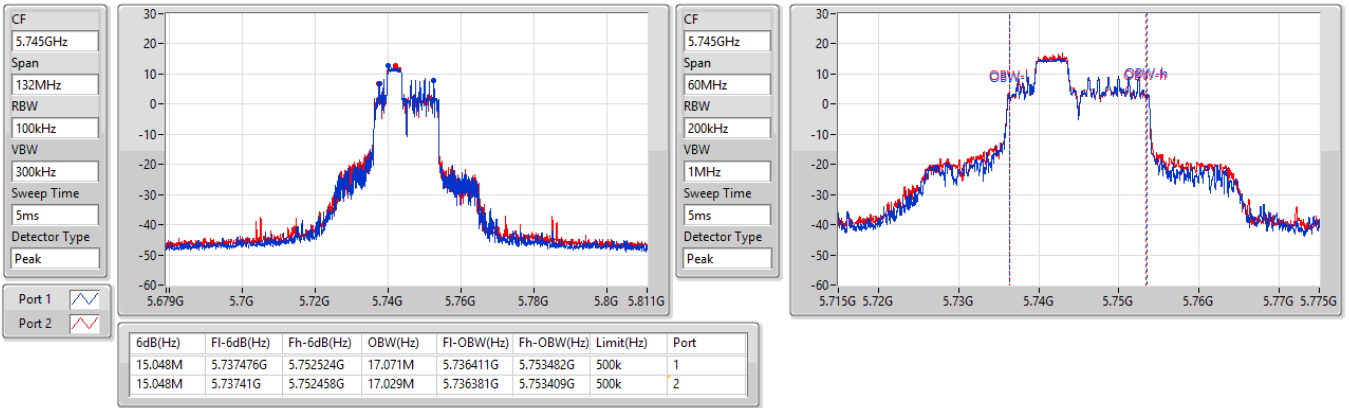

5.725-5.85GHz_802.11ax HEW20_RU52_Index38_20MHz_Nss1,(MCS0)_2TX

EBW

5745MHz

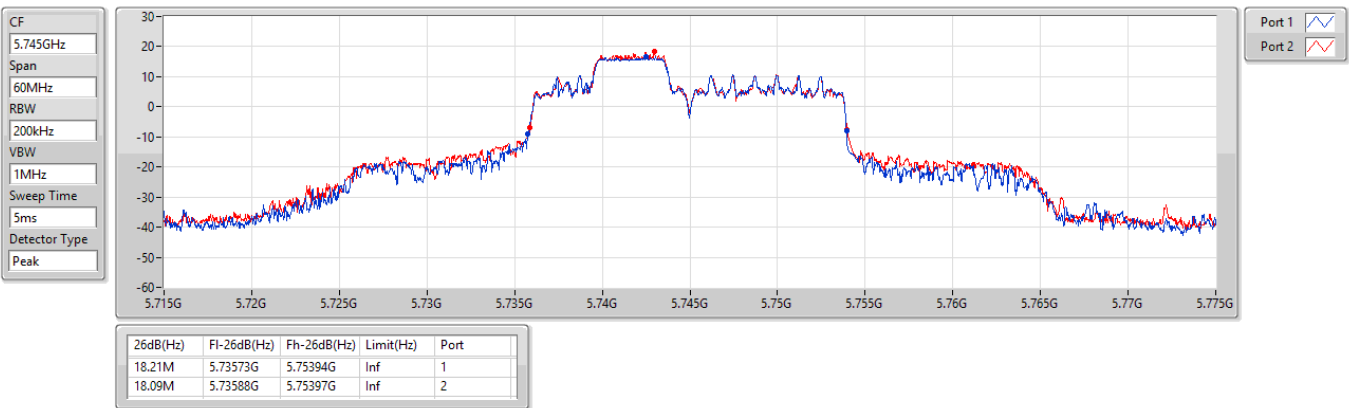



5.725-5.85GHz_802.11ax HEW20_RU52_Index38_20MHz_Nss1,(MCS0)_2TX

EBW

5785MHz

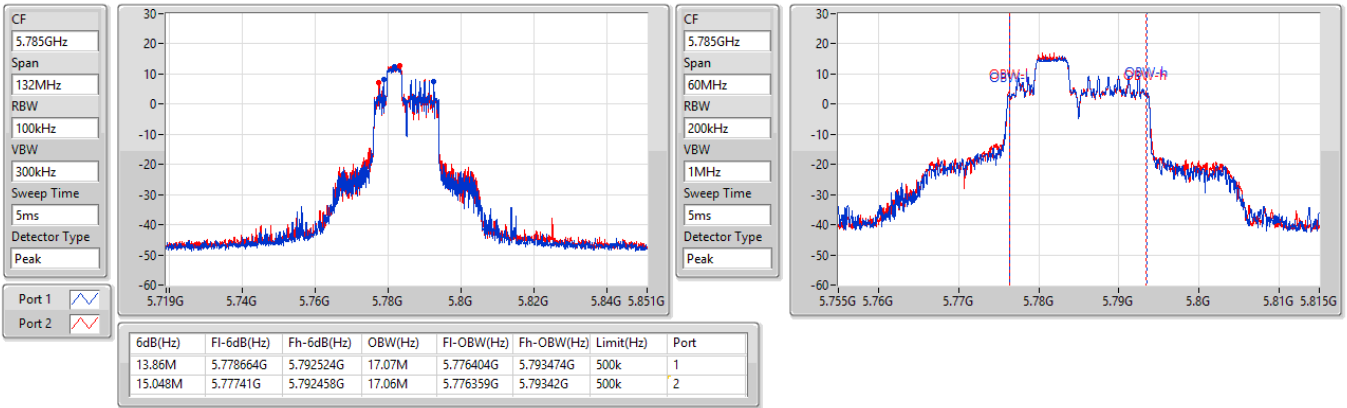

5.725-5.85GHz_802.11ax HEW20_RU52_Index38_20MHz_Nss1,(MCS0)_2TX

EBW

5785MHz

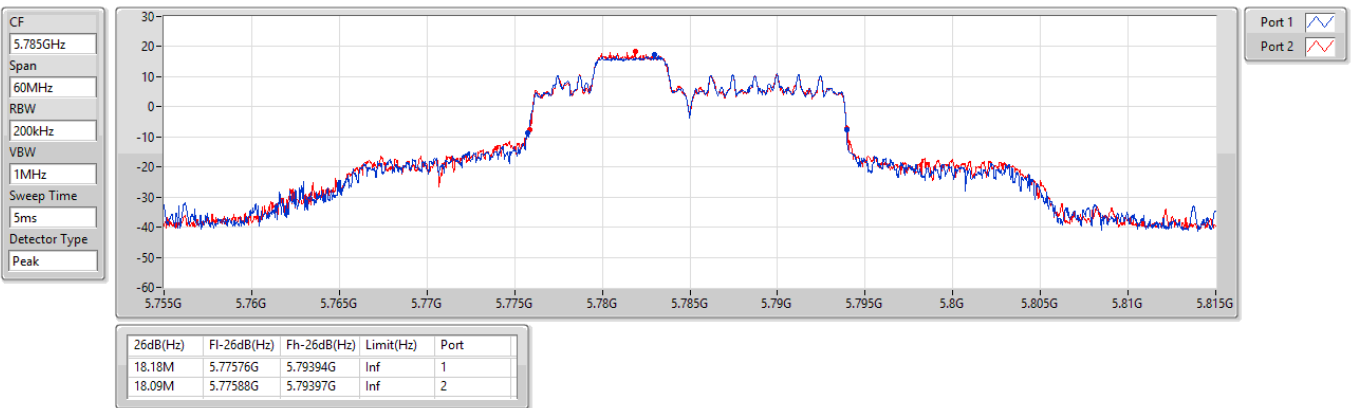



5.725-5.85GHz_802.11ax HEW20_RU52_Index38_20MHz_Nss1,(MCS0)_2TX

EBW

5825MHz

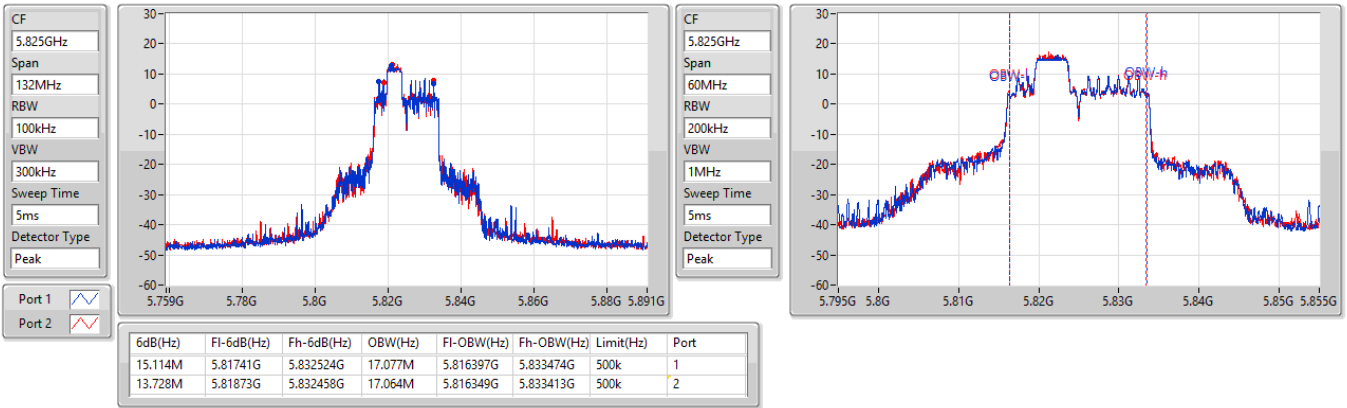

5.725-5.85GHz_802.11ax HEW20_RU52_Index38_20MHz_Nss1,(MCS0)_2TX

EBW

5825MHz

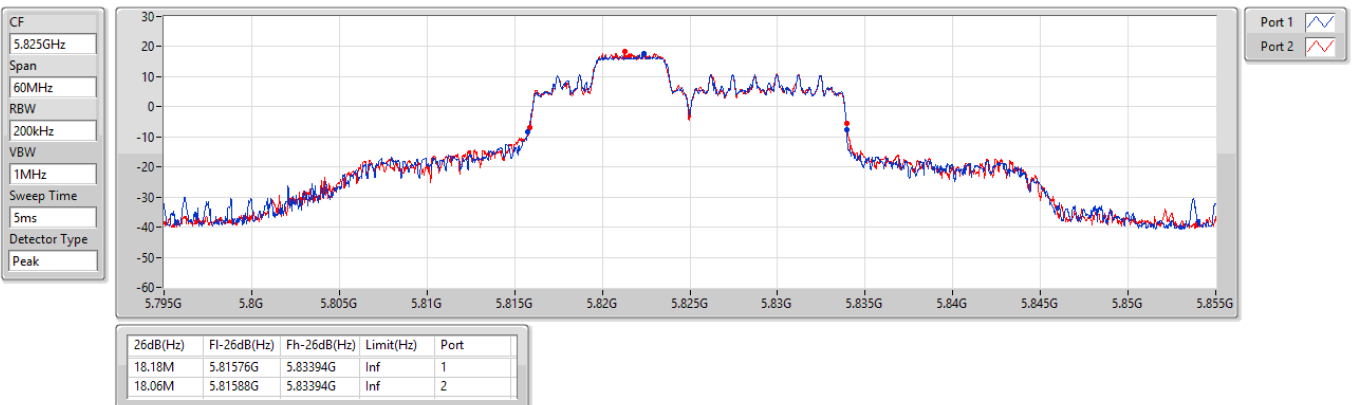

5.15-5.25GHz_802.11ax_HEW20_RU106_Index53_20MHz_Nss1,(MCS0)_2TX

EBW

5180MHz

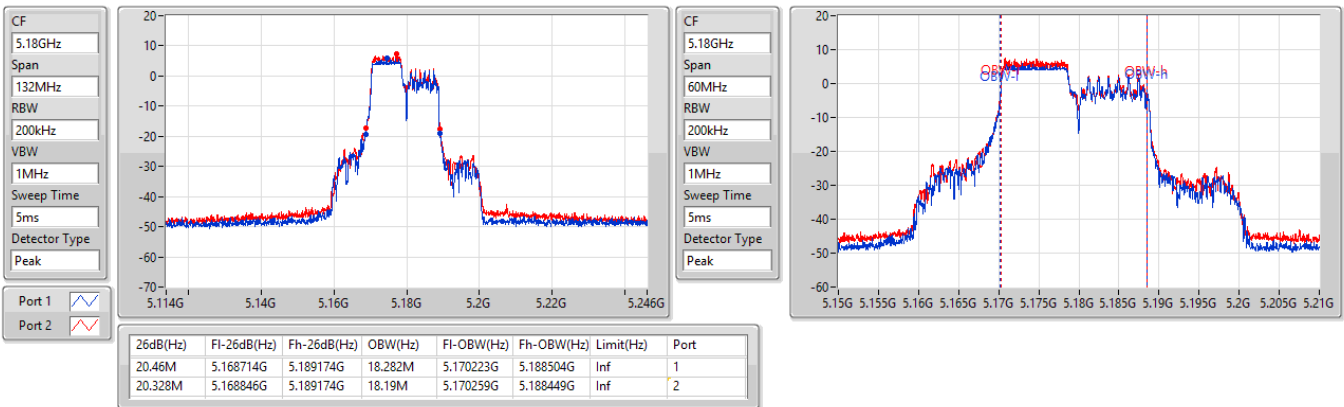

5.15-5.25GHz_802.11ax_HEW20_RU106_Index53_20MHz_Nss1,(MCS0)_2TX

EBW

5200MHz

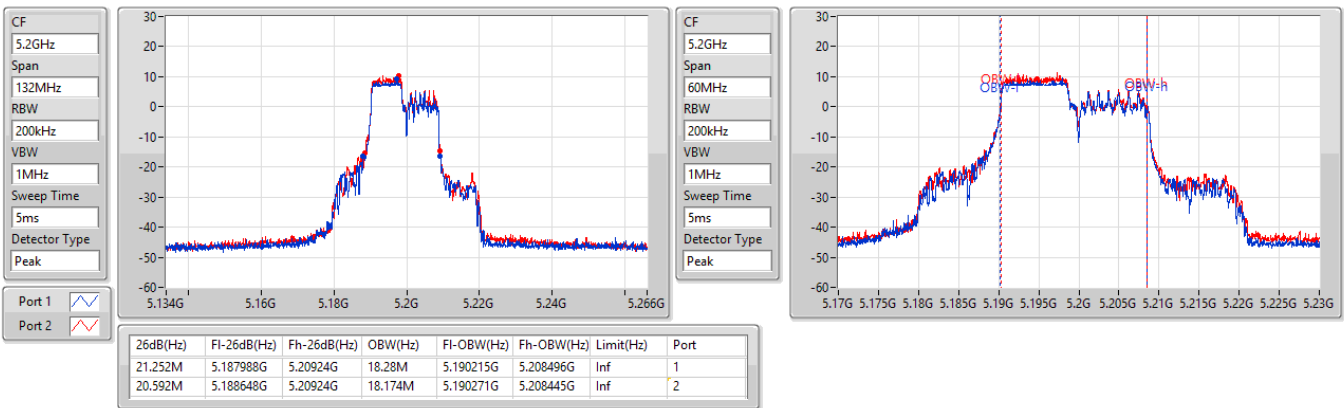

5.15-5.25GHz_802.11ax_HEW20_RU106_Index53_20MHz_Nss1,(MCS0)_2TX

EBW

5240MHz

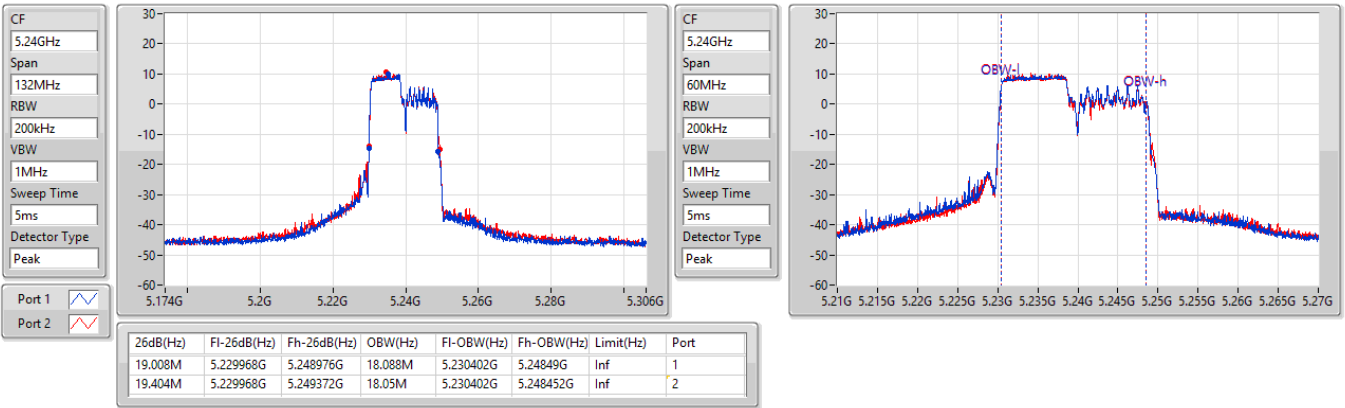

5.25-5.35GHz_802.11ax_HEW20_RU106_Index53_20MHz_Nss1,(MCS0)_2TX

EBW

5260MHz

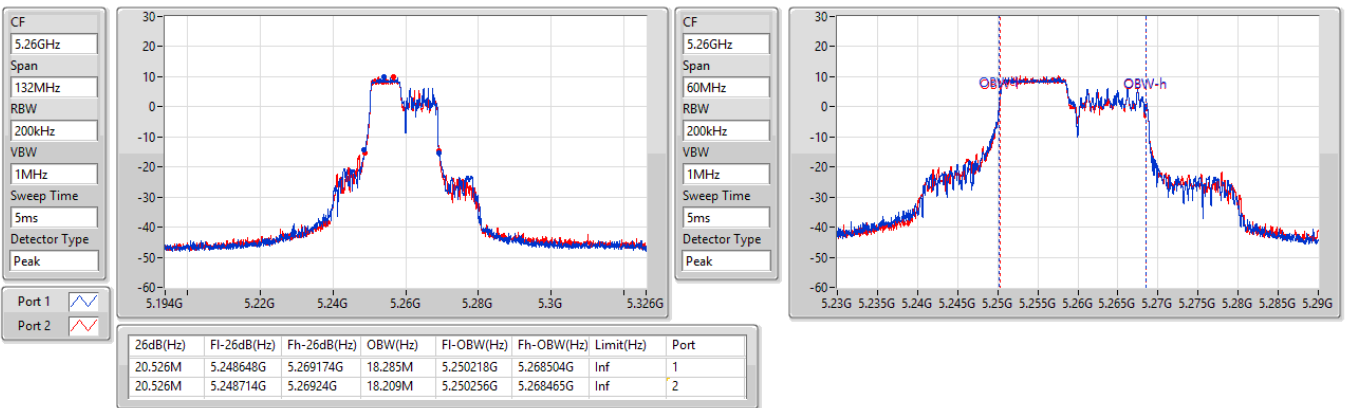

5.25-5.35GHz_802.11ax_HEW20_RU106_Index53_20MHz_Nss1,(MCS0)_2TX

EBW

5300MHz

CF: 5.3GHz
 Span: 132MHz
 RBW: 200kHz
 VBW: 1MHz
 Sweep Time: 5ms
 Detector Type: Peak

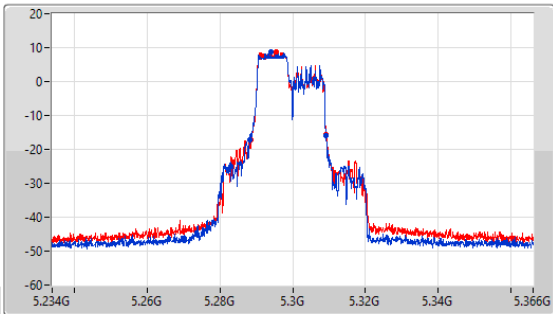

CF: 5.3GHz
 Span: 60MHz
 RBW: 200kHz
 VBW: 1MHz
 Sweep Time: 5ms
 Detector Type: Peak

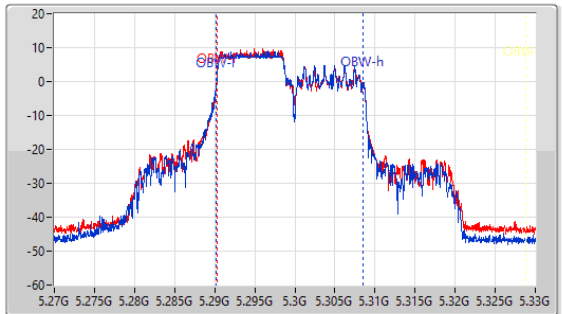

26dB(Hz)	Fl-26dB(Hz)	Fh-26dB(Hz)	OBW(Hz)	Fl-OBW(Hz)	Fh-OBW(Hz)	Limit(Hz)	Port
21.054M	5.28812G	5.309174G	18.295M	5.290215G	5.30851G	Inf	1
20.592M	5.288648G	5.30924G	18.205M	5.29025G	5.308455G	Inf	2

5.25-5.35GHz_802.11ax_HEW20_RU106_Index53_20MHz_Nss1,(MCS0)_2TX

EBW

5320MHz

CF: 5.32GHz
 Span: 132MHz
 RBW: 200kHz
 VBW: 1MHz
 Sweep Time: 5ms
 Detector Type: Peak

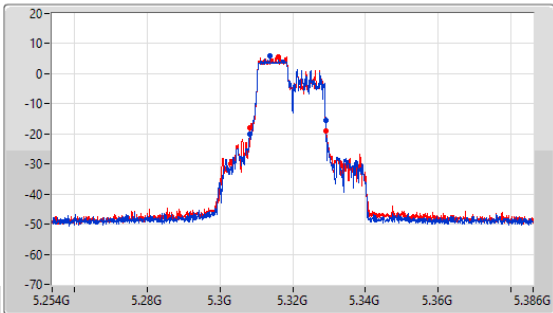

CF: 5.32GHz
 Span: 60MHz
 RBW: 200kHz
 VBW: 1MHz
 Sweep Time: 5ms
 Detector Type: Peak

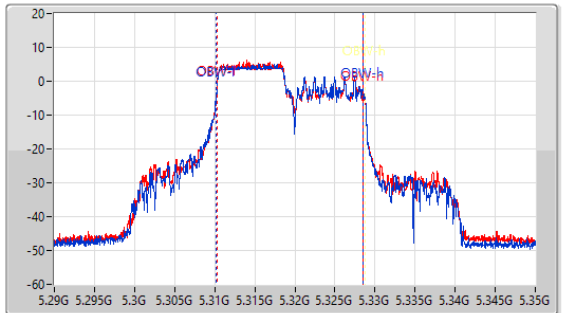

26dB(Hz)	Fl-26dB(Hz)	Fh-26dB(Hz)	OBW(Hz)	Fl-OBW(Hz)	Fh-OBW(Hz)	Limit(Hz)	Port
20.922M	5.30812G	5.329042G	18.341M	5.310218G	5.328599G	Inf	1
20.856M	5.308318G	5.329174G	18.269M	5.310262G	5.328532G	Inf	2

5.47-5.725GHz_802.11ax HEW20_RU106_Index53_20MHz_Nss1,(MCS0)_2TX

EBW

5500MHz

CF: 5.5GHz
 Span: 132MHz
 RBW: 200kHz
 VBW: 1MHz
 Sweep Time: 5ms
 Detector Type: Peak

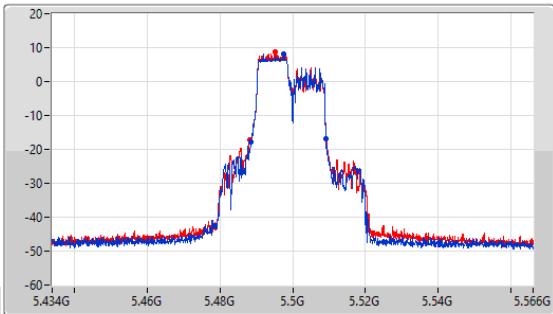

CF: 5.5GHz
 Span: 60MHz
 RBW: 200kHz
 VBW: 1MHz
 Sweep Time: 5ms
 Detector Type: Peak

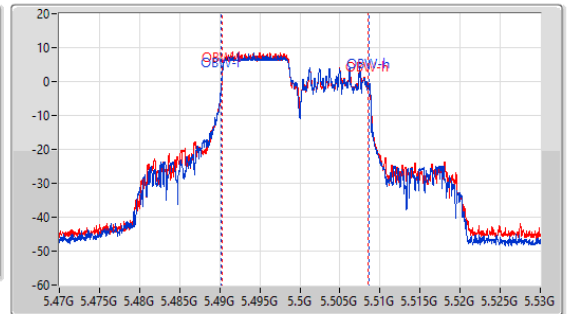

26dB(Hz)	F1-26dB(Hz)	Fh-26dB(Hz)	OBW(Hz)	F1-OBW(Hz)	Fh-OBW(Hz)	Limit(Hz)	Port
20.526M	5.488648G	5.509174G	18.367M	5.490207G	5.508574G	Inf	1
21.054M	5.488186G	5.50924G	18.262M	5.490271G	5.508532G	Inf	2

5.47-5.725GHz_802.11ax HEW20_RU106_Index53_20MHz_Nss1,(MCS0)_2TX

EBW

5580MHz

CF: 5.58GHz
 Span: 132MHz
 RBW: 200kHz
 VBW: 1MHz
 Sweep Time: 5ms
 Detector Type: Peak

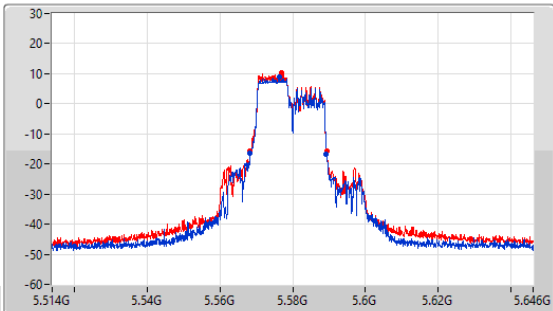

CF: 5.58GHz
 Span: 60MHz
 RBW: 200kHz
 VBW: 1MHz
 Sweep Time: 5ms
 Detector Type: Peak

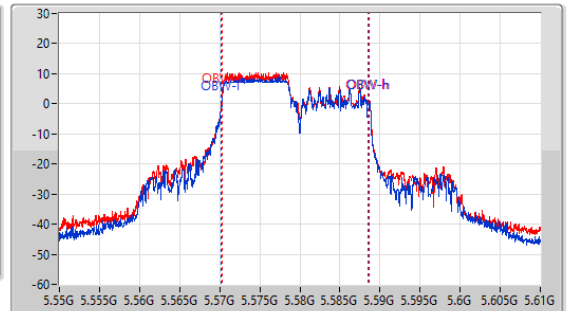

26dB(Hz)	F1-26dB(Hz)	Fh-26dB(Hz)	OBW(Hz)	F1-OBW(Hz)	Fh-OBW(Hz)	Limit(Hz)	Port
21.054M	5.568186G	5.58924G	18.337M	5.570239G	5.588576G	Inf	1
20.922M	5.568384G	5.589306G	18.285M	5.570282G	5.588567G	Inf	2

5.47-5.725GHz_802.11ax HEW20_RU106_Index53_20MHz_Nss1,(MCS0)_2TX

EBW

5700MHz

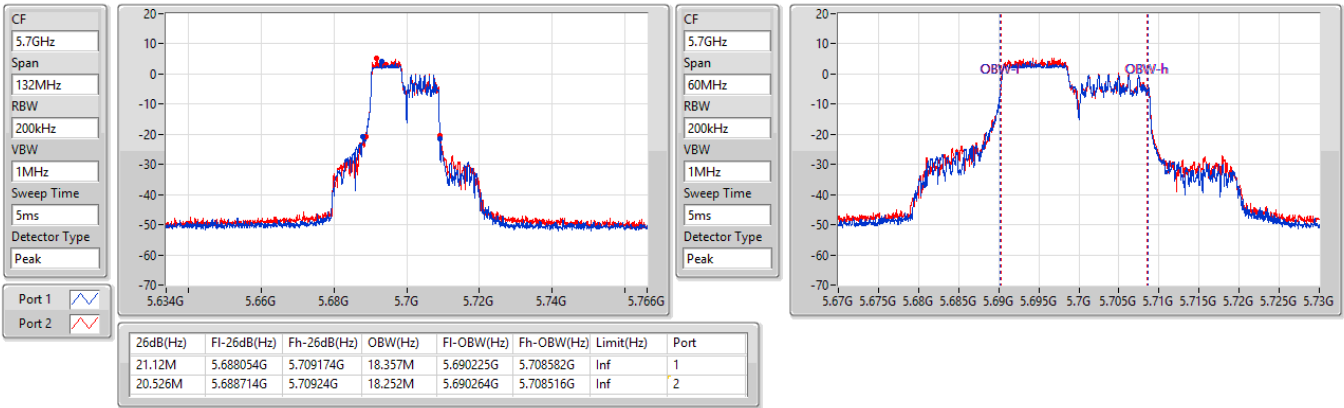

5.47-5.725GHz_802.11ax HEW20_RU106_Index53_20MHz_Nss1,(MCS0)_2TX

EBW

5720MHz Straddle 5.47-5.725GHz

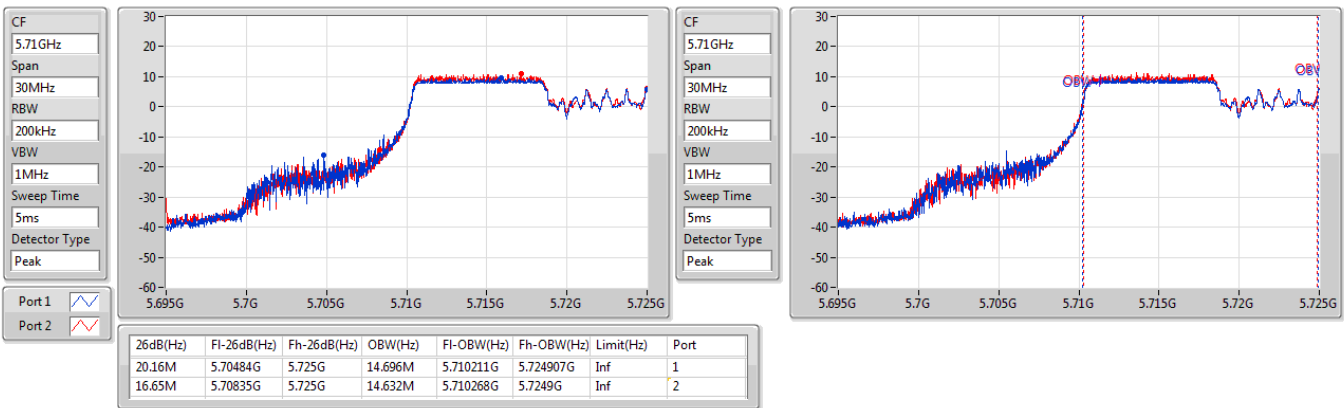



5.725-5.85GHz_802.11ax HEW20_RU106_Index53_20MHz_Nss1,(MCS0)_2TX

EBW

5720MHz Straddle 5.725-5.85GHz

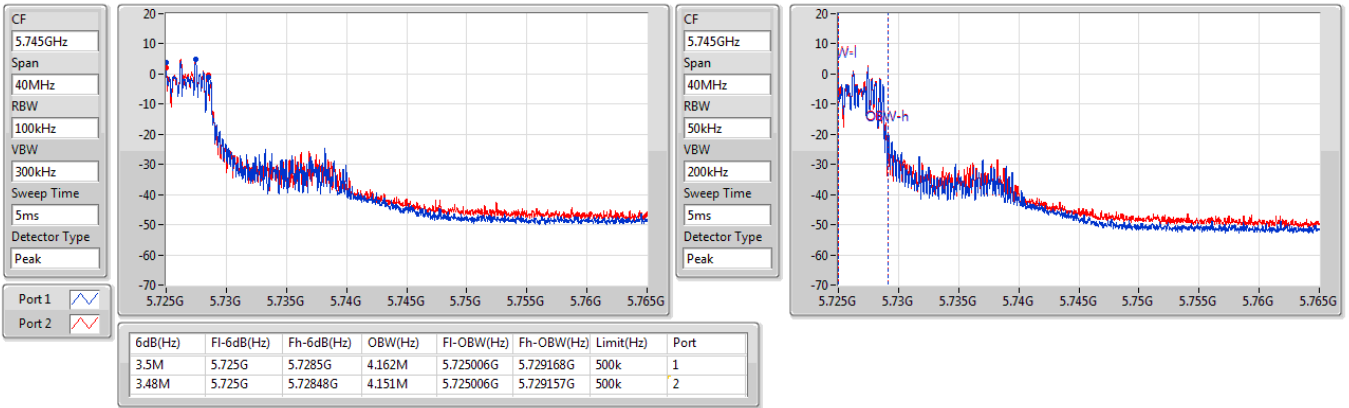

5.725-5.85GHz_802.11ax HEW20_RU106_Index53_20MHz_Nss1,(MCS0)_2TX

EBW

5720MHz Straddle 5.725-5.85GHz

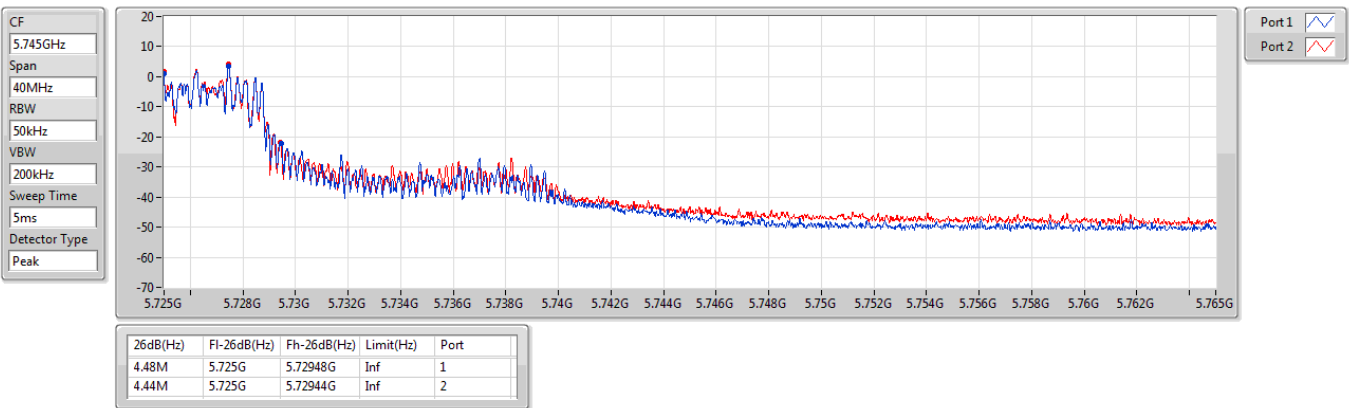



5.725-5.85GHz_802.11ax HEW20_RU106_Index53_20MHz_Nss1,(MCS0)_2TX

EBW

5745MHz

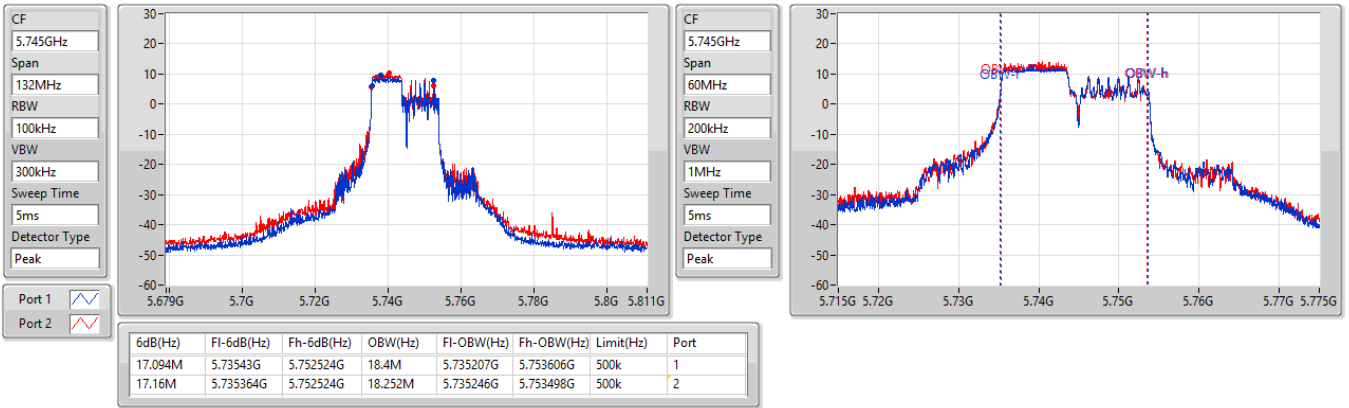

5.725-5.85GHz_802.11ax HEW20_RU106_Index53_20MHz_Nss1,(MCS0)_2TX

EBW

5745MHz

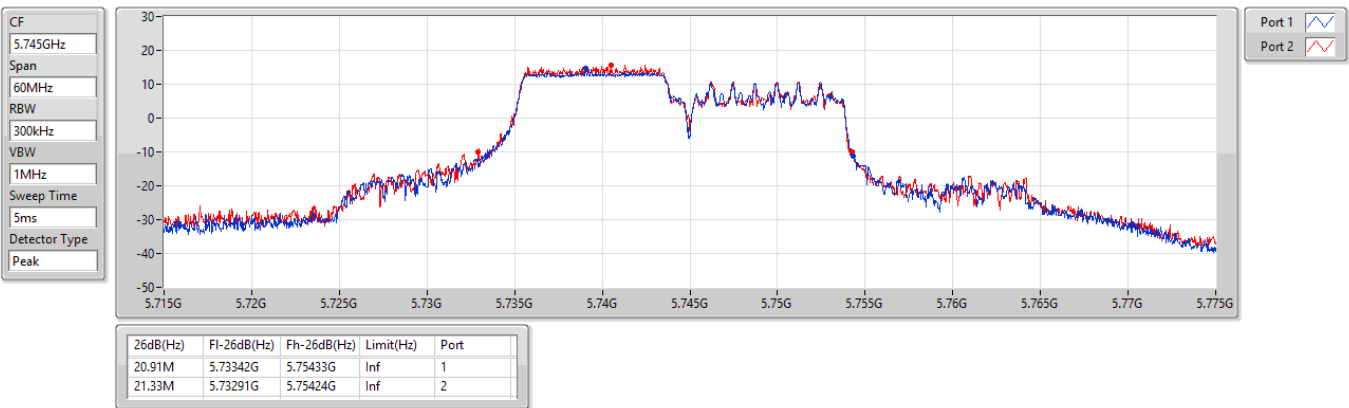



5.725-5.85GHz_802.11ax HEW20_RU106_Index53_20MHz_Nss1,(MCS0)_2TX

EBW

5785MHz

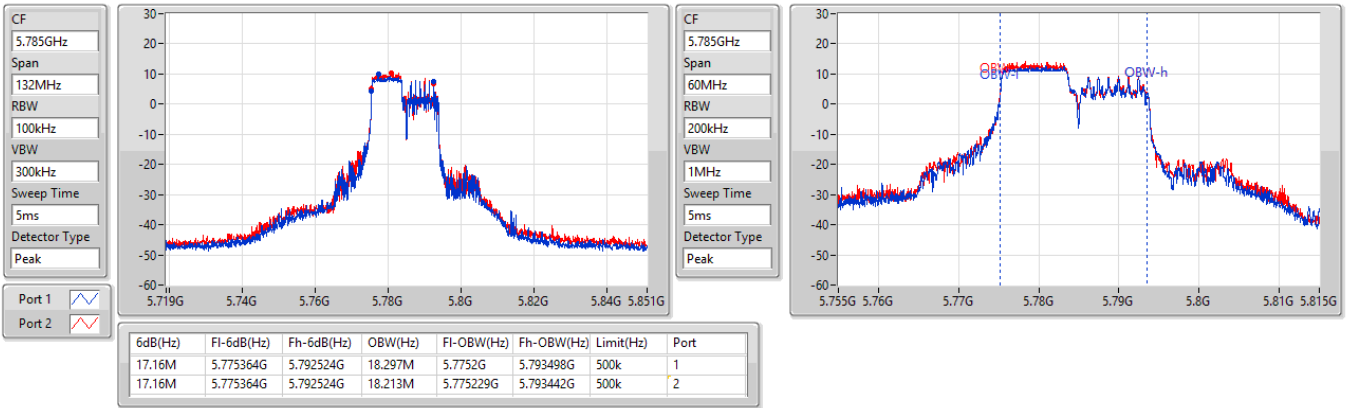

5.725-5.85GHz_802.11ax HEW20_RU106_Index53_20MHz_Nss1,(MCS0)_2TX

EBW

5785MHz

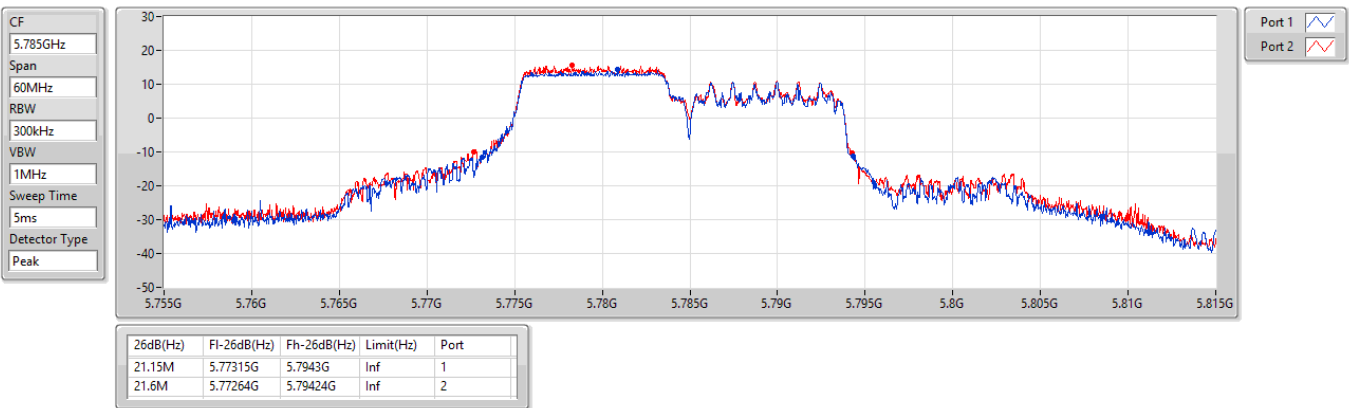



5.725-5.85GHz_802.11ax HEW20_RU106_Index53_20MHz_Nss1,(MCS0)_2TX

EBW

5825MHz

CF
5.825GHz
Span
132MHz
RBW
100kHz
VBW
300kHz
Sweep Time
5ms
Detector Type
Peak

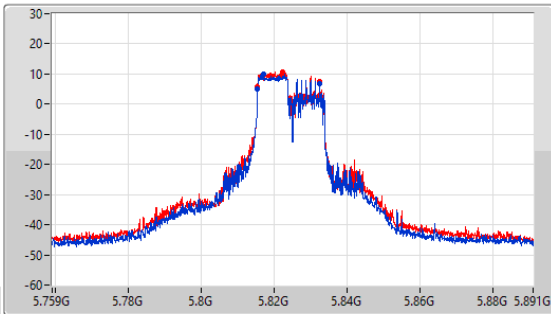

CF
5.825GHz
Span
60MHz
RBW
200kHz
VBW
1MHz
Sweep Time
5ms
Detector Type
Peak

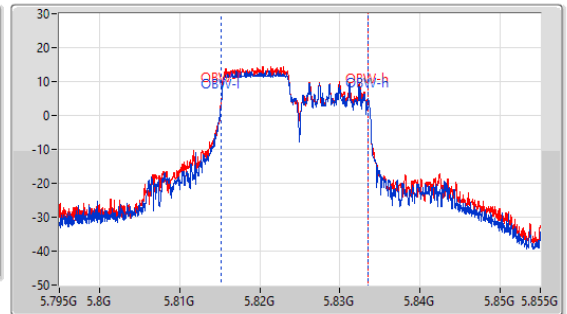

6dB(Hz)	Fl-6dB(Hz)	Fh-6dB(Hz)	OBW(Hz)	Fl-OBW(Hz)	Fh-OBW(Hz)	Limit(Hz)	Port
17.16M	5.815364G	5.832524G	18.295M	5.815208G	5.833504G	500k	1
17.16M	5.815364G	5.832524G	18.23M	5.815217G	5.833446G	500k	2

5.725-5.85GHz_802.11ax HEW20_RU106_Index53_20MHz_Nss1,(MCS0)_2TX

EBW

5825MHz

CF
5.825GHz
Span
60MHz
RBW
300kHz
VBW
1MHz
Sweep Time
5ms
Detector Type
Peak

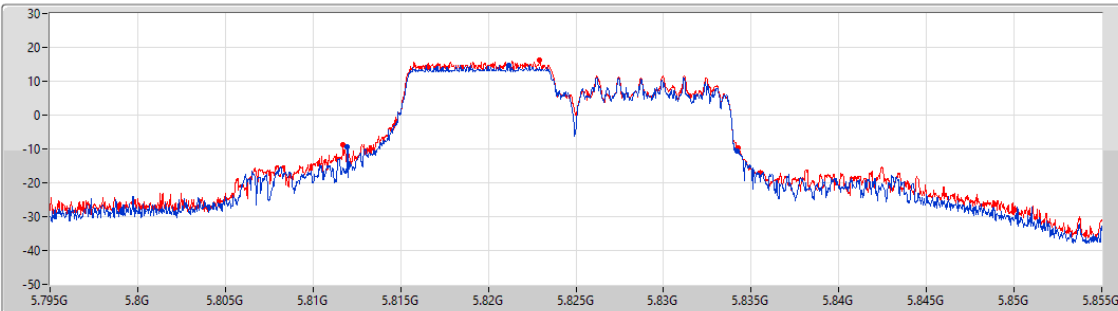

Port 1
Port 2

26dB(Hz)	Fl-26dB(Hz)	Fh-26dB(Hz)	Limit(Hz)	Port
22.26M	5.81195G	5.83421G	Inf	1
22.56M	5.81171G	5.83427G	Inf	2

5.15-5.25GHz_802.11ax_HEW40_RU26_Index12_40MHz_Nss1,(MCS0)_2TX

EBW

5190MHz

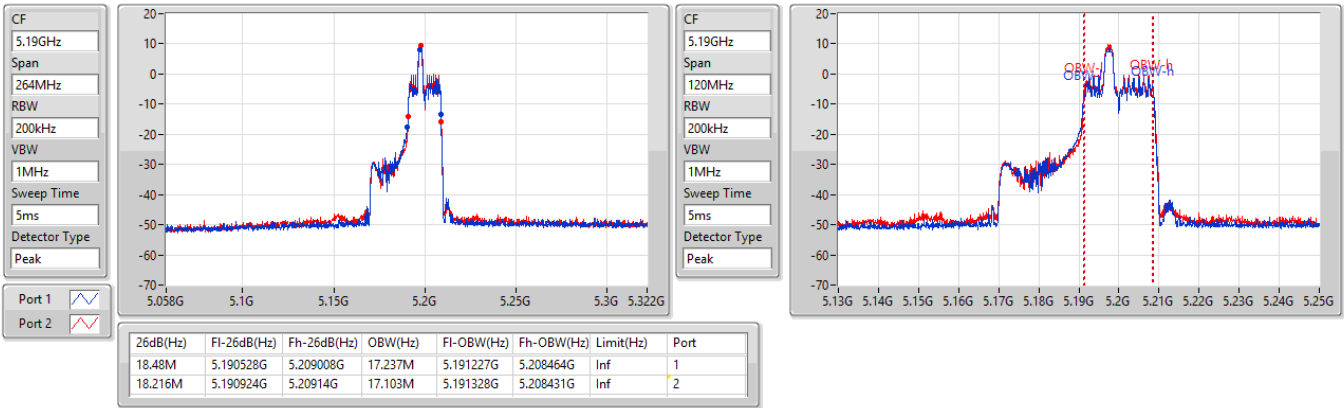

5.15-5.25GHz_802.11ax_HEW40_RU26_Index12_40MHz_Nss1,(MCS0)_2TX

EBW

5230MHz

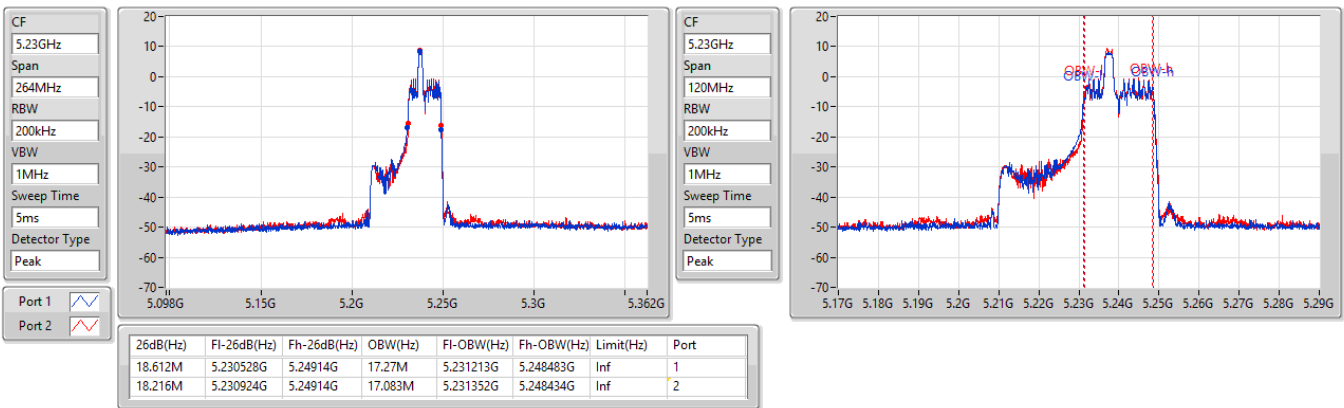

5.25-5.35GHz_802.11ax_HEW40_RU26_Index12_40MHz_Nss1,(MCS0)_2TX

EBW

5270MHz

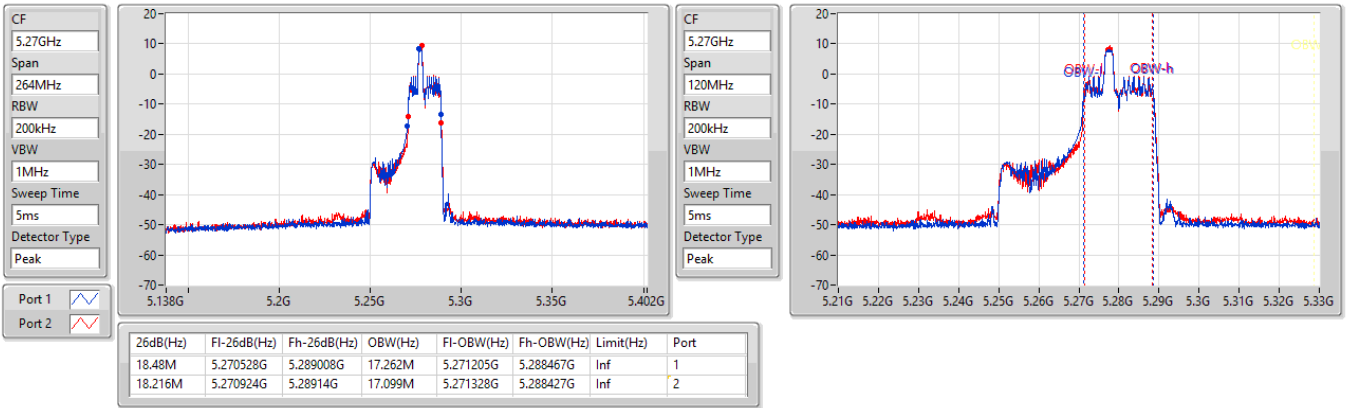

5.25-5.35GHz_802.11ax_HEW40_RU26_Index12_40MHz_Nss1,(MCS0)_2TX

EBW

5310MHz

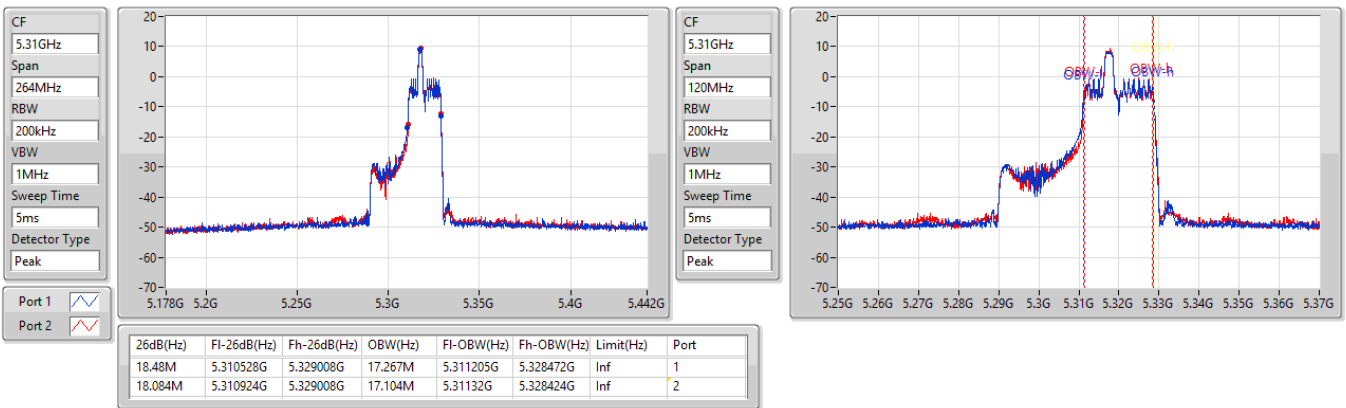

5.47-5.725GHz_802.11ax HEW40_RU26_Index12_40MHz_Nss1,(MCS0)_2TX

EBW

5510MHz

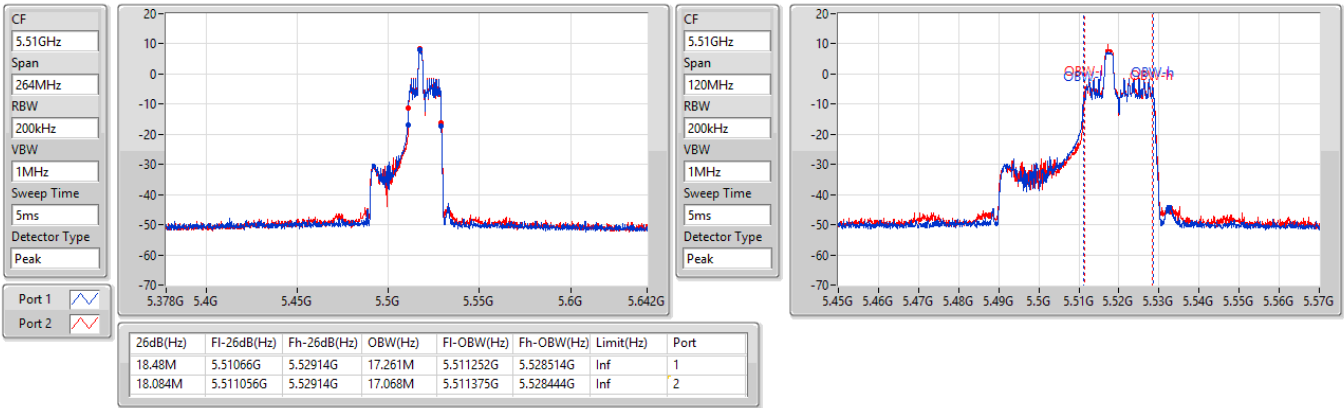

5.47-5.725GHz_802.11ax HEW40_RU26_Index12_40MHz_Nss1,(MCS0)_2TX

EBW

5590MHz

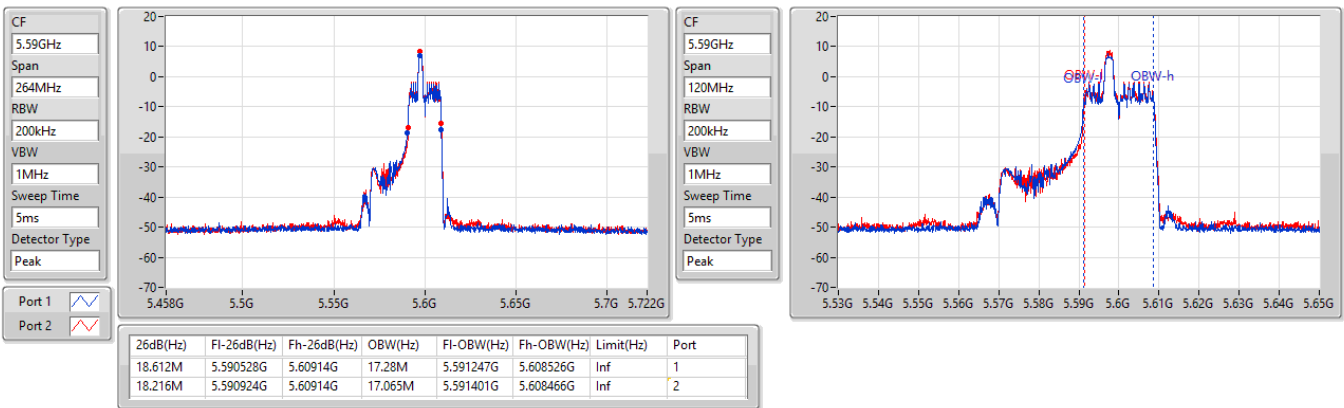

5.47-5.725GHz_802.11ax HEW40_RU26_Index12_40MHz_Nss1,(MCS0)_2TX

EBW

5670MHz

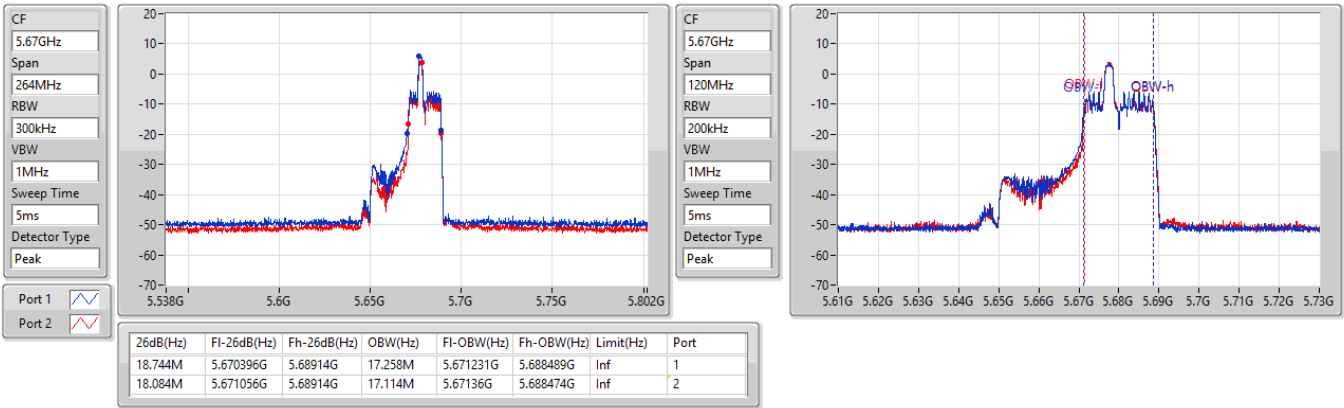

5.47-5.725GHz_802.11ax HEW40_RU26_Index12_40MHz_Nss1,(MCS0)_2TX

EBW

5710MHz Straddle 5.47-5.725GHz

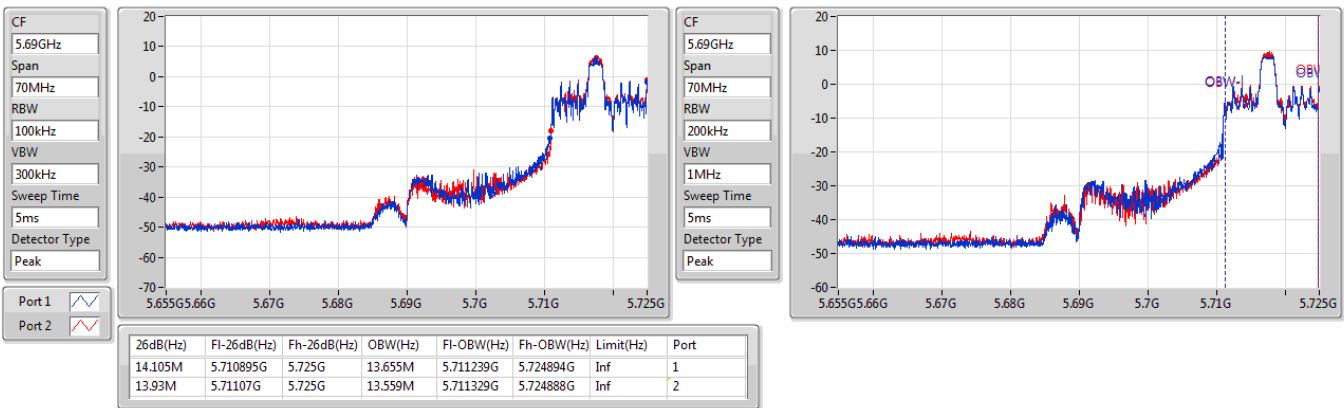



5.725-5.85GHz_802.11ax_HEW40_RU26_Index12_40MHz_Nss1,(MCS0)_2TX

EBW

5710MHz Straddle 5.725-5.85GHz

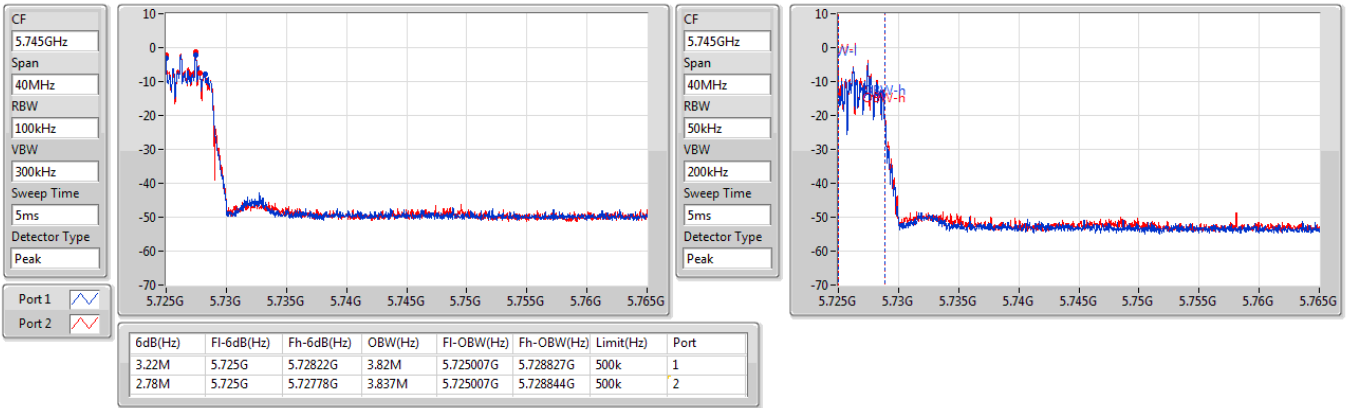

5.725-5.85GHz_802.11ax_HEW40_RU26_Index12_40MHz_Nss1,(MCS0)_2TX

EBW

5710MHz Straddle 5.725-5.85GHz

