

# FCC C2PC Test Report

**FCC ID** : SQG-LWBPLUS  
**Equipment** : 802.11n 2.4GHz + BT5.2 M.2 Module  
**Model No.** : Sterling LWB+  
**Brand Name** : Laird Connectivity  
**Applicant** : Laird Connectivity LLC  
**Address** : W66N220 Commerce Court, Cedarburg, WI  
53012 United States Of America  
**Standard** : 47 CFR FCC Part 15.247  
**Received Date** : Nov. 02, 2022  
**Tested Date** : Nov. 16 ~ Nov. 21, 2022

We, International Certification Corporation, would like to declare that the tested sample has been evaluated and in compliance with the requirement of the above standards. The test results contained in this report refer exclusively to the product. It shall not be reproduced except in full without the written approval of our laboratory.

Reviewed by:

Approved by:

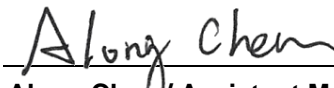
  
\_\_\_\_\_  
Along Chen / Assistant Manager

  
\_\_\_\_\_  
Gary Chang / Manager

---

## Table of Contents

|          |   |           |
|----------|---|-----------|
| <b>1</b> | <b>GENERAL DESCRIPTION .....</b>                            | <b>5</b>  |
| 1.1      | Information.....  | 5         |
| 1.2      | Local Support Equipment List .....                          | 7         |
| 1.3      | Test Setup Chart .....                                      | 7         |
| 1.4      | Test Equipment List and Calibration Data.....               | 8         |
| 1.5      | Test Standards .....  | 9         |
| 1.6      | Reference Guidance .....                                    | 9         |
| 1.7      | Deviation from Test Standard and Measurement Procedure..... | 9         |
| 1.8      | Measurement Uncertainty .....                               | 9         |
| <b>2</b> | <b>TEST CONFIGURATION.....</b>                              | <b>10</b> |
| 2.1      | Testing Facility .....                                      | 10        |
| 2.2      | The Worst Test Modes and Channel Details .....              | 10        |
| <b>3</b> | <b>TRANSMITTER TEST RESULTS .....</b>                       | <b>11</b> |
| 3.1      | Conducted Output Power .....                                | 11        |
| 3.2      | Unwanted Emissions in Restricted Frequency Bands .....      | 12        |
| 3.3      | AC Power Line Conducted Emissions .....                     | 14        |
| <b>4</b> | <b>TEST LABORATORY INFORMATION .....</b>                    | <b>15</b> |

**Appendix A. Conducted Output Power**

**Appendix B. Unwanted Emissions into Restricted Frequency Bands**

**Appendix C. AC Power Line Conducted Emissions**

---

## Release Record

| Report No.    | Version | Description   | Issued Date   |
|---------------|---------|---------------|---------------|
| FR1O0407-02AE | Rev. 01 | Initial issue | Dec. 06, 2022 |

## Summary of Test Results

| FCC Rules           | Test Items                        | Measured  | Result |
|---------------------|-----------------------------------|---|--------|
| 15.207              | AC Power Line Conducted Emissions | [dBuV]: 0.159MHz<br>44.81 (Margin -20.71dB) - QP        | Pass   |
| 15.247(d)<br>15.209 | Unwanted Emissions                | [dBuV/m at 3m]: 41.99MHz<br>36.25 (Margin -3.75dB) - PK | Pass   |
| 15.247(b)(3)        | Conducted Output Power            | Power [dBm]: 5.55                                       | Pass   |

### Declaration of Conformity:

The test results with all measurement uncertainty excluded are presented in accordance with the regulation limits or requirements declared by manufacturers.

### Comments and Explanations:

The declared of product specification for EUT presented in the report are provided by the manufacturer, and the manufacturer takes all the responsibilities for the accuracy of product specification.

# 1 General Description

## 1.1 Information

This is a Class II Permissive Change report (C2PC).

This report is issued as a supplementary report to original report no. FR1O0407AE. The differences compared to the original design is listed as follows:

- The LWB+ SIP module (Part Number 453-00083) is mounted onto the M.2 Card for new variant (Part Number 453-00141).
- Removing Chip antenna.

### 1.1.1 Product Details

| Brand name         | Model Name    | Product Name                      | Part Number | Description |
|--------------------|---------------|-----------------------------------|-------------|-------------|
| Laird Connectivity | Sterling LWB+ | 802.11n 2.4GHz + BT5.2 M.2 Module | 453-00141   | M.2 Module  |

### 1.1.2 Specification of the Equipment under Test (EUT)

| RF General Information |                |                 |                |           |
|------------------------|----------------|-----------------|----------------|-----------|
| Frequency Range (MHz)  | Bluetooth Mode | Ch. Freq. (MHz) | Channel Number | Data Rate |
| 2400-2483.5            | LE             | 2402-2480       | 0-39 [40]      | 1 Mbps    |

Note: Bluetooth LE (Low energy) uses GFSK modulation.

### 1.1.3 Antenna Details

| Ant. No. | Manufacturer | Laird Part Number | Model                     | Type       | Connector  | Gain (dBi) |
|----------|--------------|-------------------|---------------------------|------------|------------|------------|
| 1        | Laird        | 001-0001          | 2.4GHz Dipole Antenna     | Dipole     | RP-SMA     | 2          |
| 2        | Laird        | 001-0022          | FlexPIFA                  | PIFA       | IPEX MHF4L | 2          |
| 3        | Laird        | 001-0023          | FlexnNotch                | PCB Dipole | IPEX MHF4L | 2          |
| 4        | Laird        | EFA2400A3S-10MH4  | mFlexPIFA                 | PIFA       | IPEX MHF4L | 2          |
| 5        | Laird        | 001-0012          | Waterproof Dipole Antenna | Dipole     | RP-SMA     | 2          |
| 6        | Laird        | TRAB24003P        | Phantom 800MHz - 5.8GHz   | Monopole   | N-female   | 3          |

Note: Antenna 6 with highest gain was chosen for final test.

### 1.1.4 Power Supply Type of Equipment under Test (EUT)

|                          |                   |
|--------------------------|-------------------|
| <b>Power Supply Type</b> | 3.3 Vdc from host |
|--------------------------|-------------------|

### 1.1.5 Accessories

N/A

### 1.1.6 Channel List

| Frequency band (MHz) |                 |         |                 | 2400~2483.5 |                 |         |                 |
|----------------------|-----------------|---------|-----------------|-------------|-----------------|---------|-----------------|
| Channel              | Frequency (MHz) | Channel | Frequency (MHz) | Channel     | Frequency (MHz) | Channel | Frequency (MHz) |
| 37                   | 2402            | 9       | 2422            | 18          | 2442            | 28      | 2462            |
| 0                    | 2404            | 10      | 2424            | 19          | 2444            | 29      | 2464            |
| 1                    | 2406            | 38      | 2426            | 20          | 2446            | 30      | 2466            |
| 2                    | 2408            | 11      | 2428            | 21          | 2448            | 31      | 2468            |
| 3                    | 2410            | 12      | 2430            | 22          | 2450            | 32      | 2470            |
| 4                    | 2412            | 13      | 2432            | 23          | 2452            | 33      | 2472            |
| 5                    | 2414            | 14      | 2434            | 24          | 2454            | 34      | 2474            |
| 6                    | 2416            | 15      | 2436            | 25          | 2456            | 35      | 2476            |
| 7                    | 2418            | 16      | 2438            | 26          | 2458            | 36      | 2478            |
| 8                    | 2420            | 17      | 2440            | 27          | 2460            | 39      | 2480            |

### 1.1.7 Test Tool and Duty Cycle

|                        |                                      |                         |
|------------------------|--------------------------------------|-------------------------|
| <b>Test Tool</b>       | Tera Term, Version: V4.74            |                         |
| <b>Modulation Mode</b> | <b>Duty Cycle Of Test Signal (%)</b> | <b>Duty Factor (dB)</b> |
| BT-LE(1Mbps)           | 65.68%                               | 1.83                    |

### 1.1.8 Power Index of Test Tool

| Modulation Mode | Test Frequency (MHz) |         |         |
|-----------------|----------------------|---------|---------|
|                 | 2402                 | 2440    | 2480    |
| BT-LE(1Mbps)    | Default              | Default | Default |

## 1.2 Local Support Equipment List

| Support Equipment List |               |                    |                     |        |                        |
|------------------------|---------------|--------------------|---------------------|--------|------------------------|
| No.                    | Equipment     | Brand              | Model               | FCC ID | Remarks                |
| 1                      | Notebook      | DELL               | Latitude 3400       | DoC    | ---                    |
| 2                      | Fixture board | ---                | ---                 | ---    | Provided by applicant. |
| 3                      | Carrier Board | Laird Connectivity | SU60-SOMC           | ---    | Provided by applicant. |
| 4                      | Adapter       | I.T.E              | MU24AY12020<br>0-A1 | ---    | Provided by applicant. |

## 1.3 Test Setup Chart

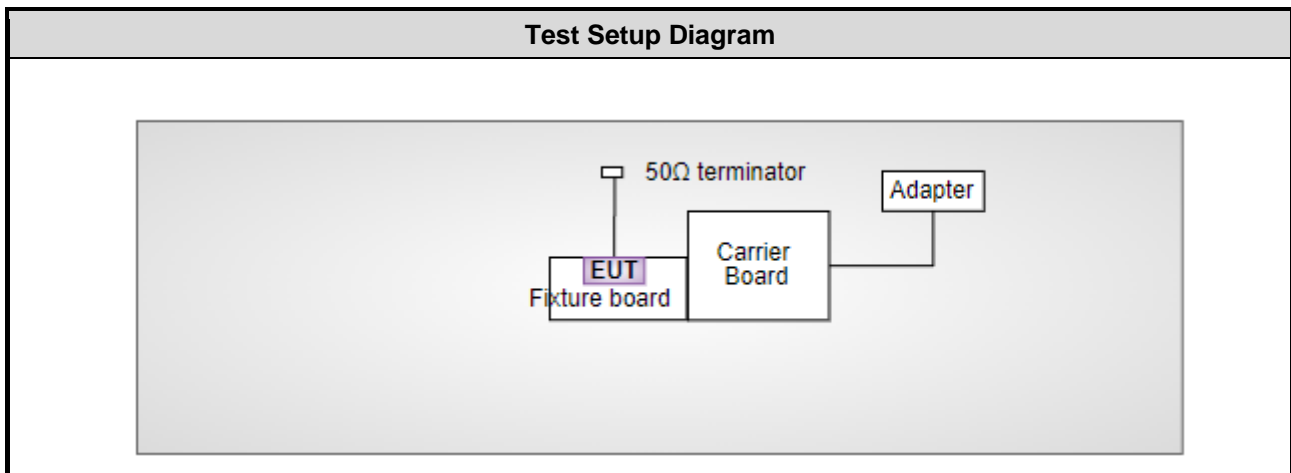

Note: The support notebook and USB cable were disconnected from EUT and removed from test table when EUT is set to transmit continuously.

## 1.4 Test Equipment List and Calibration Data

| Test Item                      | Conducted Emission            |           |               |                  |                   |
|--------------------------------|-------------------------------|-----------|---------------|------------------|-------------------|
| Test Site                      | Conduction room 1 / (CO01-WS) |           |               |                  |                   |
| Tested Date                    | Nov. 21, 2022                 |           |               |                  |                   |
| Instrument                     | Brand                         | Model No. | Serial No.    | Calibration Date | Calibration Until |
| Receiver                       | R&S                           | ESR3      | 101658        | Feb. 16, 2022    | Feb. 15, 2023     |
| LISN                           | R&S                           | ENV216    | 101579        | Apr. 21, 2022    | Apr. 20, 2023     |
| LISN (Support Unit)            | SCHWARZBECK                   | NSLK 8127 | 8127667       | Jan .07, 2022    | Jan .06, 2023     |
| RF Cable-CON                   | Woken                         | CFD200-NL | CFD200-NL-001 | Oct. 17, 2022    | Oct. 16, 2023     |
| 50 ohm terminal (Support Unit) | NA                            | 50        | 04            | May 10, 2022     | May 09, 2023      |
| Measurement Software           | AUDIX                         | e3        | 6.120210k     | NA               | NA                |

Note: Calibration Interval of instruments listed above is one year.

| Test Item            | Radiated Emission          |                   |                     |                  |                   |
|----------------------|----------------------------|-------------------|---------------------|------------------|-------------------|
| Test Site            | 966 chamber3 / (03CH03-WS) |                   |                     |                  |                   |
| Tested Date          | Nov. 17, 2022              |                   |                     |                  |                   |
| Instrument           | Brand                      | Model No.         | Serial No.          | Calibration Date | Calibration Until |
| Receiver             | R&S                        | ESR3              | 101657              | Mar. 15, 2022    | Mar. 14, 2023     |
| Spectrum Analyzer    | R&S                        | FSV40             | 101499              | Mar. 08, 2022    | Mar. 07, 2023     |
| Loop Antenna         | R&S                        | HFH2-Z2           | 100330              | Nov. 01, 2022    | Oct. 31, 2023     |
| Bilog Antenna        | SCHWARZBECK                | VULB9168          | VULB9168-685        | Jun. 28, 2022    | Jun. 27, 2023     |
| Horn Antenna 1G-18G  | SCHWARZBECK                | BBHA 9120 D       | BBHA 9120 D 1206    | Dec. 20, 2021    | Dec. 19, 2022     |
| Horn Antenna 18G-40G | SCHWARZBECK                | BBHA 9170         | BBHA 9170508        | Jan. 11, 2022    | Jan. 10, 2023     |
| Preamplifier         | EMC                        | EMC02325          | 980187              | Jul. 16, 2022    | Jul. 15, 2023     |
| Preamplifier         | EMC                        | EMC184045SE       | 980897              | Aug. 01, 2022    | Jul. 31, 2023     |
| Preamplifier         | EMC                        | EMC184045SE       | 980903              | Jul. 16, 2022    | Jul. 15, 2023     |
| Loop Antenna Cable   | KOAX KABEL                 | 101354-BW         | 101354-BW           | Oct. 04, 2022    | Oct. 03, 2023     |
| LF cable-0.8M        | EMC                        | EMC8D-NM-NM-800   | EMC8D-NM-NM-800-001 | Sep. 23, 2022    | Sep. 22, 2023     |
| LF cable-3M          | EMC                        | EMC8D-NM-NM-3000  | 131103              | Sep. 23, 2022    | Sep. 22, 2023     |
| LF cable-13M         | EMC                        | EMC8D-NM-NM-13000 | 131104              | Sep. 23, 2022    | Sep. 22, 2023     |
| RF cable-3M          | HUBER+SUHNER               | SUCOFLEX104       | MY22620/4           | Sep. 23, 2022    | Sep. 22, 2023     |
| RF cable-8M          | EMC                        | EMC104-SM-SM-8000 | 181107              | Sep. 23, 2022    | Sep. 22, 2023     |
| Measurement Software | AUDIX                      | e3                | 6.120210g           | NA               | NA                |

Note: Calibration Interval of instruments listed above is one year.



|   |               |                  |                   |                         |                          |
|---|---------------|------------------|-------------------|-------------------------|--------------------------|
| <b>Test Item</b>  | RF Conducted  |                  |                   |                         |                          |
| <b>Test Site</b>  | (TH01-WS)     |                  |                   |                         |                          |
| <b>Tested Date</b>  | Nov. 16, 2022 |                  |                   |                         |                          |
| <b>Instrument</b>   | <b>Brand</b>  | <b>Model No.</b> | <b>Serial No.</b> | <b>Calibration Date</b> | <b>Calibration Until</b> |
| Spectrum Analyzer   | R&S           | FSV40            | 101910            | Apr. 18, 2022           | Apr. 17, 2023            |
| Power Meter   | Anritsu       | ML2495A          | 1241001           | Jan. 14, 2022           | Jan. 13, 2023            |
| Power Sensor  | Anritsu       | MA2411B          | 1911228           | Jan. 14, 2022           | Jan. 13, 2023            |
| Measurement Software  | Sporton       | SENSE-15247_FS   | V5.10.7.11        | NA                      | NA                       |
| Note: Calibration Interval of instruments listed above is one year. |               |                  |                   |                         |                          |

## 1.5 Test Standards

47 CFR FCC Part 15.247  
ANSI C63.10-2013

## 1.6 Reference Guidance

FCC KDB 558074 D01 15.247 Meas Guidance v05r02

## 1.7 Deviation from Test Standard and Measurement Procedure

None

## 1.8 Measurement Uncertainty

The measurement uncertainties given below are based on a 95% confidence level (based on a coverage factor ( $k=2$ )).

| Measurement Uncertainty        |                |
|--------------------------------|----------------|
| Parameters                     | Uncertainty    |
| Conducted power                | $\pm 0.808$ dB |
| AC conducted emission          | $\pm 2.92$ dB  |
| Unwanted Emission $\leq 1$ GHz | $\pm 3.96$ dB  |
| Unwanted Emission $> 1$ GHz    | $\pm 4.51$ dB  |

## 2 Test Configuration

### 2.1 Testing Facility

|                             |  |
|-----------------------------|--|
| <b>Test Laboratory</b>      | International Certification Corporation  |
| <b>Test Site</b>            | CO01-WS, TH01-WS   |
| <b>Address of Test Site</b> | No.3-1, Lane 6, Wen San 3rd St., Kwei Shan Dist., Tao Yuan City 33381, Taiwan (R.O.C.) |
| <b>Test Site</b>            | 03CH03-WS  |
| <b>Address of Test Site</b> | No.14-1, Lane 19, Wen San 3rd St., Kwei Shan Dist., Tao Yuan City 333, Taiwan (R.O.C.) |

- FCC Designation No.: TW0009
- FCC site registration No.: 207696
- ISED#: 10807C
- CAB identifier: TW2732

### 2.2 The Worst Test Modes and Channel Details

- The tests reported herein were performed according to the original worst case conditions in original report no. FR1O0407AE.

| Test item                         | Mode         | Test Frequency (MHz) | Test Configuration |
|-----------------------------------|--------------|----------------------|--------------------|
| AC Power Line Conducted Emissions | BT-LE(1Mbps) | 2402                 | ---                |
| Unwanted Emissions ≤ 1GHz         | BT-LE(1Mbps) | 2402                 | ---                |
| Unwanted Emissions > 1GHz         | BT-LE(1Mbps) | 2440                 | ---                |
| Conducted Output Power            | BT-LE(1Mbps) | 2402, 2440, 2480     | ---                |

**NOTE:**

1. The EUT was pretested with 3 orientations placed on the table for the radiated emission measurement – X, Y, and Z-plane. The **Z-plane** results were found as the worst case and were shown in this report.

### 3 Transmitter Test Results

#### 3.1 Conducted Output Power

##### 3.1.1 Limit of Conducted Output Power

Conducted power shall not exceed 1Watt.

Antenna gain  $\leq 6\text{dBi}$ , no any corresponding reduction is in output power limit.

##### 3.1.2 Test Procedures

A broadband RF power meter is used for output power measurement. The video bandwidth of power meter is greater than DTS bandwidth of EUT. If duty cycle of test signal is not 100 %, trigger and gating function of power meter will be enabled to capture transmission burst for measuring output power.

##### 3.1.3 Test Setup

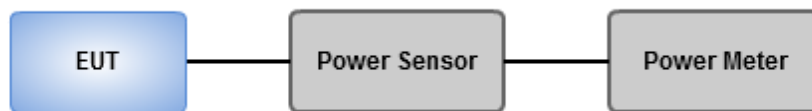

##### 3.1.4 Test Results

|                   |            |           |          |
|-------------------|------------|-----------|----------|
| Ambient Condition | 24°C / 66% | Tested By | Roger Lu |
|-------------------|------------|-----------|----------|

Refer to Appendix A.

## 3.2 Unwanted Emissions in Restricted Frequency Bands

### 3.2.1 Limit of Unwanted Emissions in Restricted Frequency Bands

| Restricted Band Emissions Limit |                       |                         |                      |
|---------------------------------|-----------------------|-------------------------|----------------------|
| Frequency Range (MHz)           | Field Strength (uV/m) | Field Strength (dBuV/m) | Measure Distance (m) |
| 0.009~0.490                     | 2400/F(kHz)           | 48.5 - 13.8             | 300                  |
| 0.490~1.705                     | 24000/F(kHz)          | 33.8 - 23               | 30                   |
| 1.705~30.0                      | 30                    | 29                      | 30                   |
| 30~88                           | 100                   | 40                      | 3                    |
| 88~216                          | 150                   | 43.5                    | 3                    |
| 216~960                         | 200                   | 46                      | 3                    |
| Above 960                       | 500                   | 54                      | 3                    |

**Note 1:**  
Quasi-Peak value is measured for frequency below 1GHz except for 9–90 kHz, 110–490 kHz frequency band. Peak and average value are measured for frequency above 1GHz. The limit on average radio frequency emission is as above table. The limit on peak radio frequency emissions is 20 dB above the maximum permitted average emission limit

**Note 2:**  
Measurements may be performed at a distance other than what is specified provided. When performing measurements at a distance other than that specified, the results shall be extrapolated to the specified distance using an extrapolation factor as below, Frequency at or above 30 MHz: 20 dB/decade Frequency below 30 MHz: 40 dB/decade.

### 3.2.2 Test Procedures

1. Measurement is made at a semi-anechoic chamber that incorporates a turntable allowing a EUT rotation of 360°. A continuously-rotating, remotely-controlled turntable is installed at the test site to support the EUT and facilitate determination of the direction of maximum radiation for each EUT emission frequency. The EUT is placed at test table. For emissions testing at or below 1 GHz, the table height is 80 cm above the reference ground plane. For emission measurements above 1 GHz, the table height is 1.5 m
2. Measurement is made with the antenna positioned in both the horizontal and vertical planes of polarization. The measurement antenna is varied in height (1m ~ 4m) above the reference ground plane to obtain the maximum signal strength. Distance between EUT and antenna is 3 m.
3. This investigation is performed with the EUT rotated 360°, the antenna height scanned between 1 m and 4 m, and the antenna rotated to repeat the measurements for both the horizontal and vertical antenna polarizations.

Note:

1. 120kHz measurement bandwidth of test receiver and Quasi-peak detector is for radiated emission below 1GHz.
2. RBW=1MHz, VBW=3MHz and Peak detector is for peak measured value of radiated emission above 1GHz.
3. RBW=1MHz, VBW=1/T and Peak detector is for average measured value of radiated emission above 1GHz.

### 3.2.3 Test Setup

#### Radiated Emissions below 1 GHz

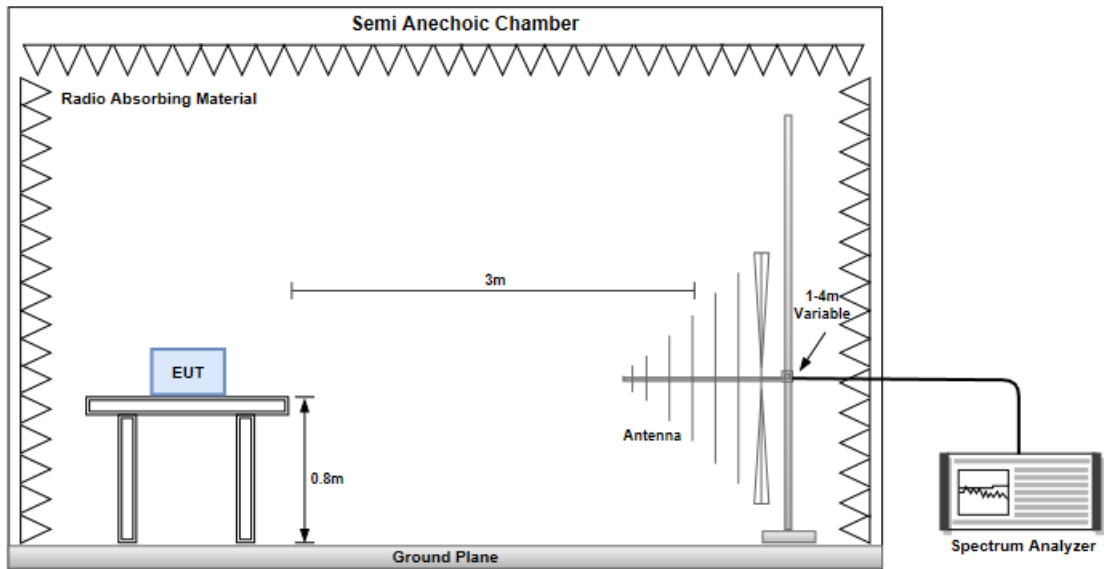

#### Radiated Emissions above 1 GHz

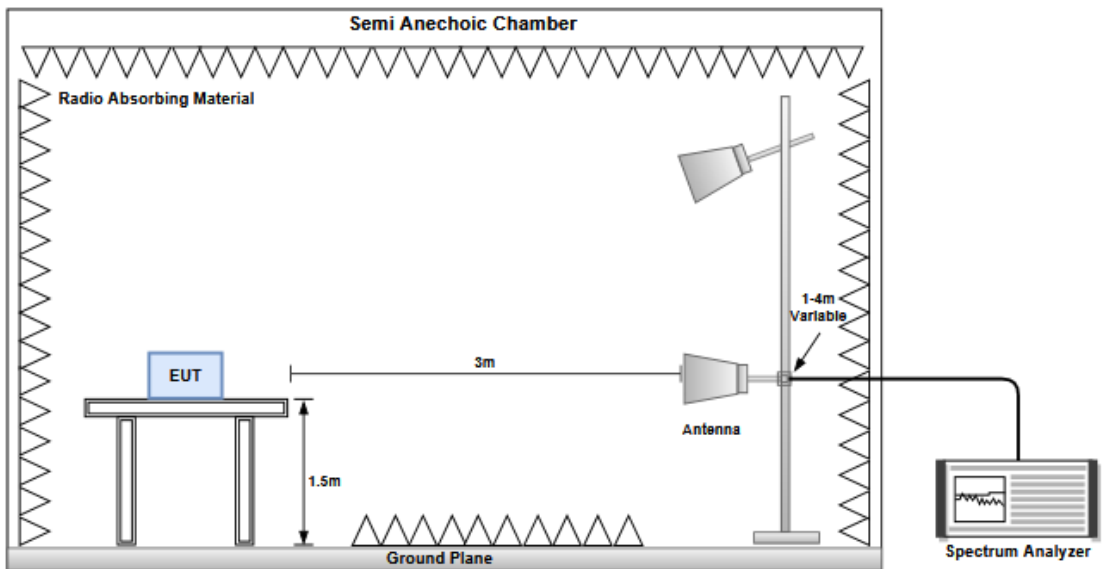

### 3.2.4 Test Results

Refer to Appendix B.

### 3.3 AC Power Line Conducted Emissions

#### 3.3.1 Limit of AC Power Line Conducted Emissions

| Conducted Emissions Limit |            |           |
|---------------------------|------------|-----------|
| Frequency Emission (MHz)  | Quasi-Peak | Average   |
| 0.15-0.5                  | 66 - 56 *  | 56 - 46 * |
| 0.5-5                     | 56         | 46        |
| 5-30                      | 60         | 50        |

Note 1: \* Decreases with the logarithm of the frequency.

#### 3.3.2 Test Procedures

1. The device is placed on a test table, raised 80 cm above the reference ground plane. The vertical conducting plane is located 40 cm to the rear of the device.
2. The device is connected to line impedance stabilization network (LISN) and other accessories are connected to other LISN. Measured levels of AC power line conducted emission are across the 50  $\Omega$  LISN port.
3. AC conducted emission measurements is made over frequency range from 150 kHz to 30 MHz.
4. This measurement was performed with AC 120V/60Hz

#### 3.3.3 Test Setup

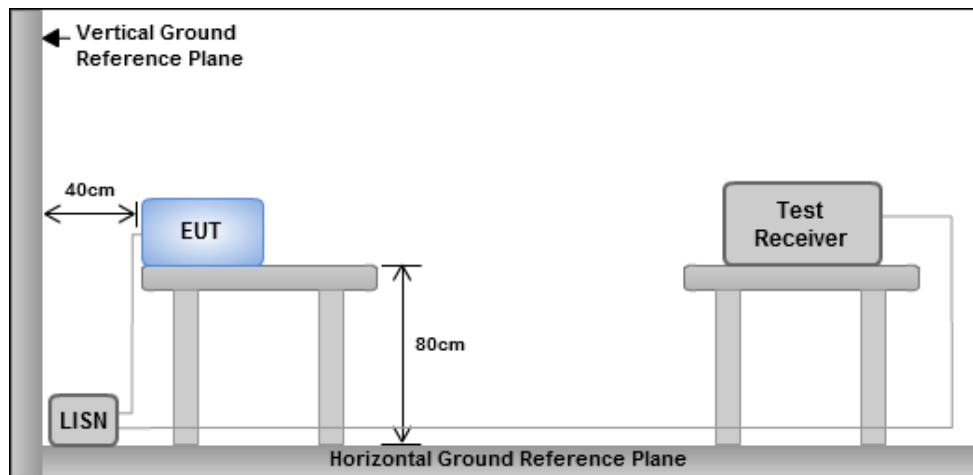

- Note: 1. Support units were connected to second LISN.  
2. Both of LISNs (AMN) are 80 cm from EUT and at least 80 cm from other units and other metal planes

#### 3.3.4 Test Results

Refer to Appendix C.

## 4 Test laboratory information

Established in 2012, ICC provides foremost EMC & RF Testing and advisory consultation services by our skilled engineers and technicians. Our services employ a wide variety of advanced edge test equipment and one of the widest certification extents in the business.

International Certification Corporation (EMC and Wireless Communication Laboratory), it is our definitive objective is to institute long term, trust-based associations with our clients. The expectation we set up with our clients is based on outstanding service, practical expertise and devotion to a certified value structure. Our passion is to grant our clients with best EMC / RF services by oriented knowledgeable and accommodating staff.

Our Test sites are located at Linkou District and Kwei Shan District. Location map can be found on our website <http://www.icertifi.com.tw>.

### **Linkou**

Tel: 886-2-2601-1640

No.30-2, Ding Fwu Tsuen, Lin Kou  
District, New Taipei City, Taiwan  
(R.O.C.)

### **Kwei Shan**

Tel: 886-3-271-8666

No.3-1, Lane 6, Wen San 3rd  
St., Kwei Shan Dist., Tao Yuan  
City 33381, Taiwan (R.O.C.)  
No.2-1, Lane 6, Wen San 3rd  
St., Kwei Shan Dist., Tao Yuan  
City 33381, Taiwan (R.O.C.)

### **Kwei Shan Site II**

Tel: 886-3-271-8640

No.14-1, Lane 19, Wen San 3rd  
St., Kwei Shan Dist., Tao Yuan  
City 333, Taiwan (R.O.C.)

If you have any suggestion, please feel free to contact us as below information.

Tel: 886-3-271-8666

Fax: 886-3-318-0155

Email: ICC\_Service@icertifi.com.tw

==END==



## Conducted Output Power (Peak)

## Appendix A.1

### Summary

| Mode          | Power (dBm) | Power (W) |
|---------------|-------------|-----------|
| 2.4-2.4835GHz | -           | -         |
| BT-LE(1Mbps)  | 5.55        | 0.00359   |

### Result

| Mode         | Result | Antenna Gain (dBi) | Power (dBm) | Power Limit (dBm) |
|--------------|--------|--------------------|-------------|-------------------|
| BT-LE(1Mbps) | -      | -                  | -           | -                 |
| 2402MHz      | Pass   | 3.00               | 5.55        | 30.00             |
| 2440MHz      | Pass   | 3.00               | 5.34        | 30.00             |
| 2480MHz      | Pass   | 3.00               | 4.85        | 30.00             |





## Conducted Output Power (Average)

## Appendix A.2

### Summary

| Mode          | Power (dBm) | Power (W) |
|---------------|-------------|-----------|
| 2.4-2.4835GHz | -           | -         |
| BT-LE(1Mbps)  | 5.32        | 0.00340   |

### Result

| Mode         | Result | Antenna Gain (dBi) | Power (dBm) | Power Limit (dBm) |
|--------------|--------|--------------------|-------------|-------------------|
| BT-LE(1Mbps) | -      | -                  | -           | -                 |
| 2402MHz      | Pass   | 3.00               | 5.32        | -                 |
| 2440MHz      | Pass   | 3.00               | 5.15        | -                 |
| 2480MHz      | Pass   | 3.00               | 4.65        | -                 |

Note: Average power is for reference only.



Unwanted Emissions (Below 1GHz)

|              |              |                  |      |
|--------------|--------------|------------------|------|
| Modulation   | BT-LE(1Mbps) | Test Freq. (MHz) | 2402 |
| Polarization | Horizontal   |                  |      |

Test By :Akun Chung      Temperature(°C):25      Humidity(%):66

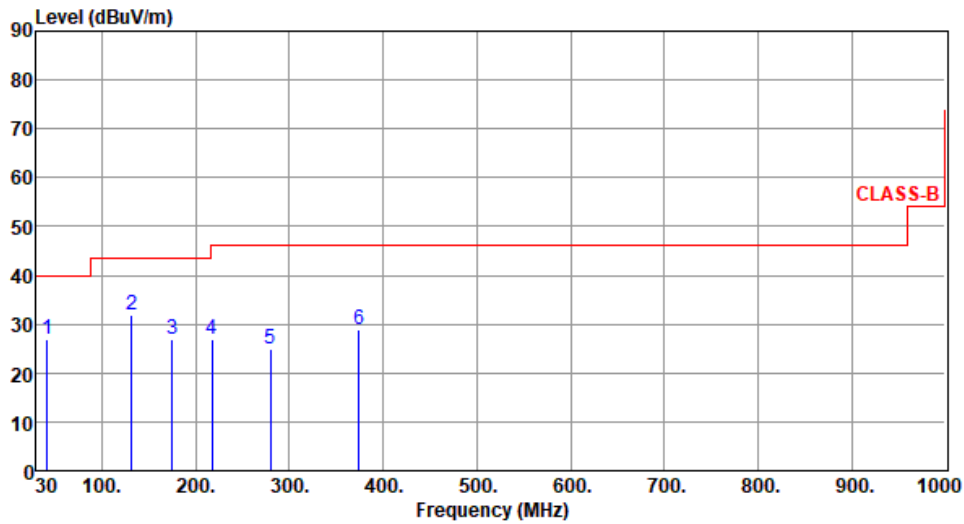

|   | Freq. MHz | Emission level dBuV/m | Limit dBuV/m | Margin dB | SA reading dBuV | Factor dB/m | Remark | ANT High cm | Turn Table deg |
|---|-----------|-----------------------|--------------|-----------|-----------------|-------------|--------|-------------|----------------|
| 1 | 41.59     | 26.95                 | 40.00        | -13.05    | 36.05           | -9.10       | Peak   | ---         | ---            |
| 2 | 131.55    | 31.87                 | 43.50        | -11.63    | 41.88           | -10.01      | Peak   | ---         | ---            |
| 3 | 175.25    | 26.75                 | 43.50        | -16.75    | 36.15           | -9.40       | Peak   | ---         | ---            |
| 4 | 217.63    | 26.96                 | 46.00        | -19.04    | 38.70           | -11.74      | Peak   | ---         | ---            |
| 5 | 279.58    | 24.93                 | 46.00        | -21.07    | 33.41           | -8.48       | Peak   | ---         | ---            |
| 6 | 374.22    | 28.87                 | 46.00        | -17.13    | 34.71           | -5.84       | Peak   | ---         | ---            |

Note 1: Emission Level (dBuV/m) = SA Reading (dBuV) + Factor\* (dB/m)

\*Factor includes antenna factor , cable loss and amplifier gain

Note 2: Margin (dB) = Emission level (dBuV/m) – Limit (dBuV/m).

Note 3: All spurious emissions below 30MHz are more than 20 dB below the limit.



|                     |              |                         |      |
|---------------------|--------------|-------------------------|------|
| <b>Modulation</b>   | BT-LE(1Mbps) | <b>Test Freq. (MHz)</b> | 2402 |
| <b>Polarization</b> | Vertical     |                         |      |

Test By :Akun Chung      Temperature(°C):25      Humidity(%):66

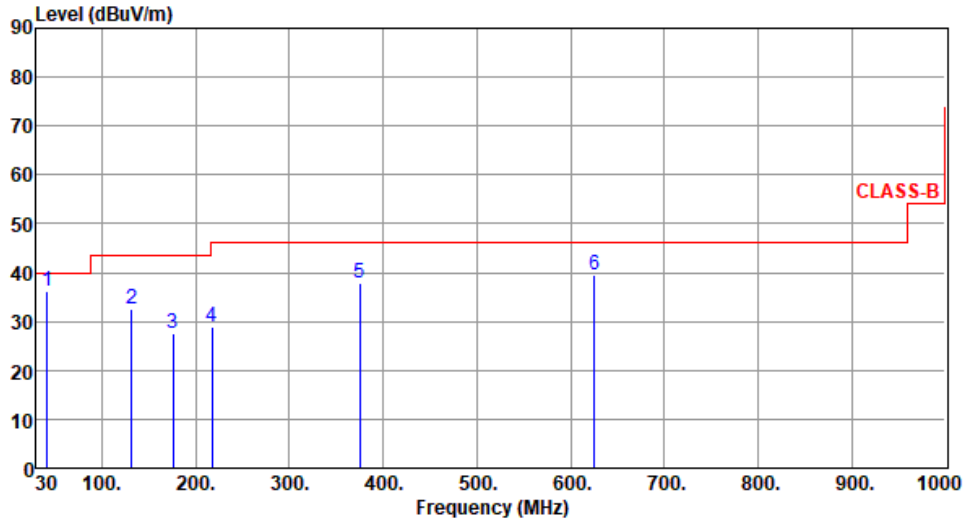

|   | Freq.<br>MHz | Emission<br>level<br>dBuV/m | Limit<br>dBuV/m | Margin<br>dB | SA<br>reading<br>dBuV | Factor<br>dB/m | Remark | ANT<br>High<br>cm | Turn<br>Table<br>deg |
|---|--------------|-----------------------------|-----------------|--------------|-----------------------|----------------|--------|-------------------|----------------------|
| 1 | 41.99        | 36.25                       | 40.00           | -3.75        | 45.22                 | -8.97          | Peak   | ---               | ---                  |
| 2 | 131.25       | 32.63                       | 43.50           | -10.87       | 42.64                 | -10.01         | Peak   | ---               | ---                  |
| 3 | 175.58       | 27.45                       | 43.50           | -16.05       | 36.92                 | -9.47          | Peak   | ---               | ---                  |
| 4 | 217.36       | 28.95                       | 46.00           | -17.05       | 40.69                 | -11.74         | Peak   | ---               | ---                  |
| 5 | 375.22       | 37.93                       | 46.00           | -8.07        | 43.72                 | -5.79          | Peak   | ---               | ---                  |
| 6 | 625.22       | 39.47                       | 46.00           | -6.53        | 38.80                 | 0.67           | Peak   | ---               | ---                  |

Note 1: Emission Level (dBuV/m) = SA Reading (dBuV) + Factor\* (dB/m)

\*Factor includes antenna factor , cable loss and amplifier gain

Note 2: Margin (dB) = Emission level (dBuV/m) – Limit (dBuV/m).

Note 3: All spurious emissions below 30MHz are more than 20 dB below the limit.



Unwanted Emission (Above 1GHz)

|              |              |                  |      |
|--------------|--------------|------------------|------|
| Modulation   | BT-LE(1Mbps) | Test Freq. (MHz) | 2440 |
| Polarization | Horizontal   |                  |      |

Test By :Akun Chung      Temperature(°C):25      Humidity(%):66

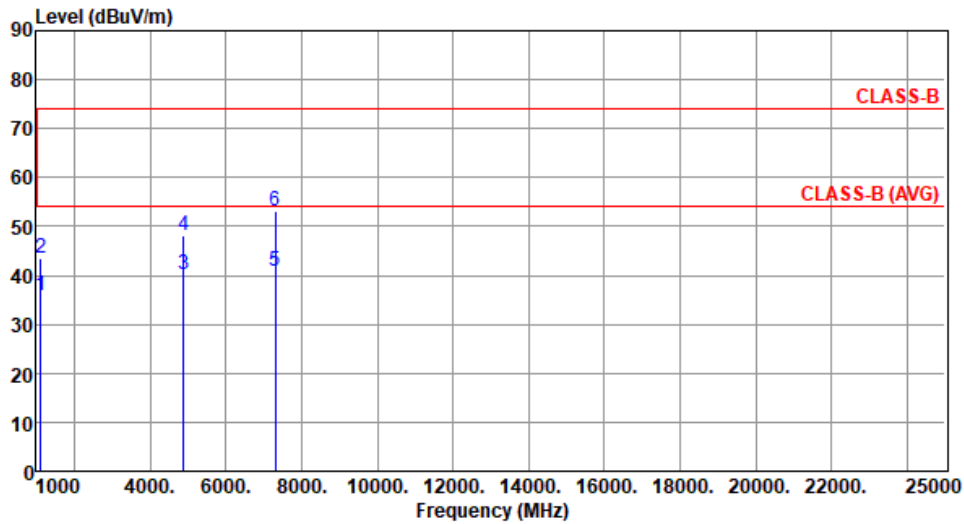

|   | Freq. MHz | Emission level dBuV/m | Limit dBuV/m | Margin dB | SA reading dBuV | Factor dB/m | Remark  | ANT High cm | Turn Table deg |
|---|-----------|-----------------------|--------------|-----------|-----------------|-------------|---------|-------------|----------------|
| 1 | 1125.00   | 35.89                 | 54.00        | -18.11    | 42.45           | -6.56       | Average | 169         | 350            |
| 2 | 1125.00   | 43.42                 | 74.00        | -30.58    | 49.98           | -6.56       | Peak    | 169         | 350            |
| 3 | 4880.00   | 40.02                 | 54.00        | -13.98    | 40.36           | -0.34       | Average | 102         | 309            |
| 4 | 4880.00   | 48.30                 | 74.00        | -25.70    | 48.64           | -0.34       | Peak    | 102         | 309            |
| 5 | 7320.00   | 40.95                 | 54.00        | -13.05    | 35.18           | 5.77        | Average | 107         | 306            |
| 6 | 7320.00   | 53.24                 | 74.00        | -20.76    | 47.47           | 5.77        | Peak    | 107         | 306            |

Note 1: Emission Level (dBuV/m) = SA Reading (dBuV) + Factor\* (dB/m)

\*Factor includes antenna factor , cable loss and amplifier gain

Note 2: Margin (dB) = Emission level (dBuV/m) – Limit (dBuV/m).



|              |              |                  |      |
|--------------|--------------|------------------|------|
| Modulation   | BT-LE(1Mbps) | Test Freq. (MHz) | 2440 |
| Polarization | Vertical     |                  |      |

Test By :Akun Chung      Temperature(°C):25      Humidity(%):66

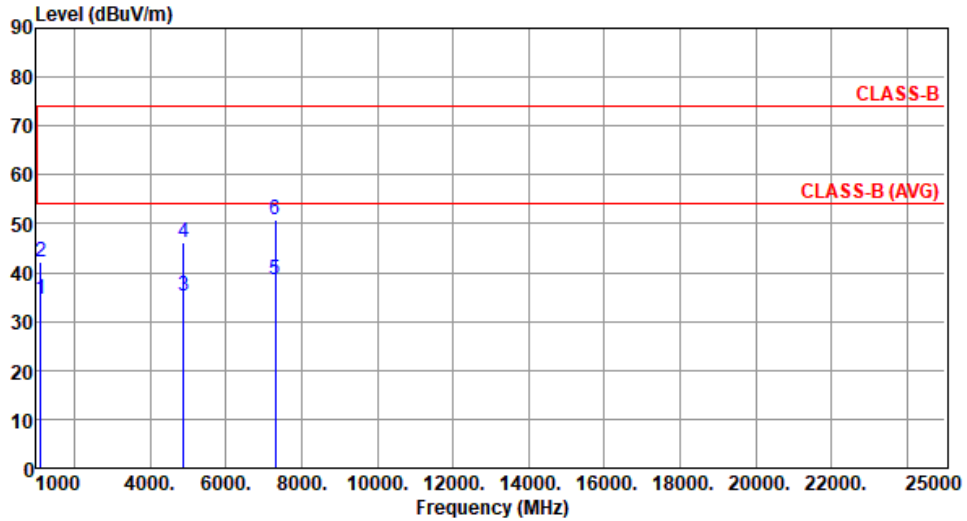

|   | Freq.<br>MHz | Emission<br>level<br>dBuV/m | Limit<br>dBuV/m | Margin<br>dB | SA<br>reading<br>dBuV | Factor<br>dB/m | Remark  | ANT<br>High<br>cm | Turn<br>Table<br>deg |
|---|--------------|-----------------------------|-----------------|--------------|-----------------------|----------------|---------|-------------------|----------------------|
| 1 | 1125.00      | 34.46                       | 54.00           | -19.54       | 41.02                 | -6.56          | Average | 185               | 13                   |
| 2 | 1125.00      | 42.10                       | 74.00           | -31.90       | 48.66                 | -6.56          | Peak    | 185               | 13                   |
| 3 | 4880.00      | 35.36                       | 54.00           | -18.64       | 35.70                 | -0.34          | Average | 100               | 112                  |
| 4 | 4880.00      | 46.27                       | 74.00           | -27.73       | 46.61                 | -0.34          | Peak    | 100               | 112                  |
| 5 | 7320.00      | 38.43                       | 54.00           | -15.57       | 32.66                 | 5.77           | Average | 100               | 85                   |
| 6 | 7320.00      | 50.65                       | 74.00           | -23.35       | 44.88                 | 5.77           | Peak    | 100               | 85                   |

Note 1: Emission Level (dBuV/m) = SA Reading (dBuV) + Factor\* (dB/m)

\*Factor includes antenna factor , cable loss and amplifier gain

Note 2: Margin (dB) = Emission level (dBuV/m) – Limit (dBuV/m).



|             |              |                  |      |
|-------------|--------------|------------------|------|
| Modulation  | BT-LE(1Mbps) | Test Freq. (MHz) | 2402 |
| Power Phase | Line         |                  |      |

Test by : Joe Liao      Temperature: 22°C      Humidity: 63%

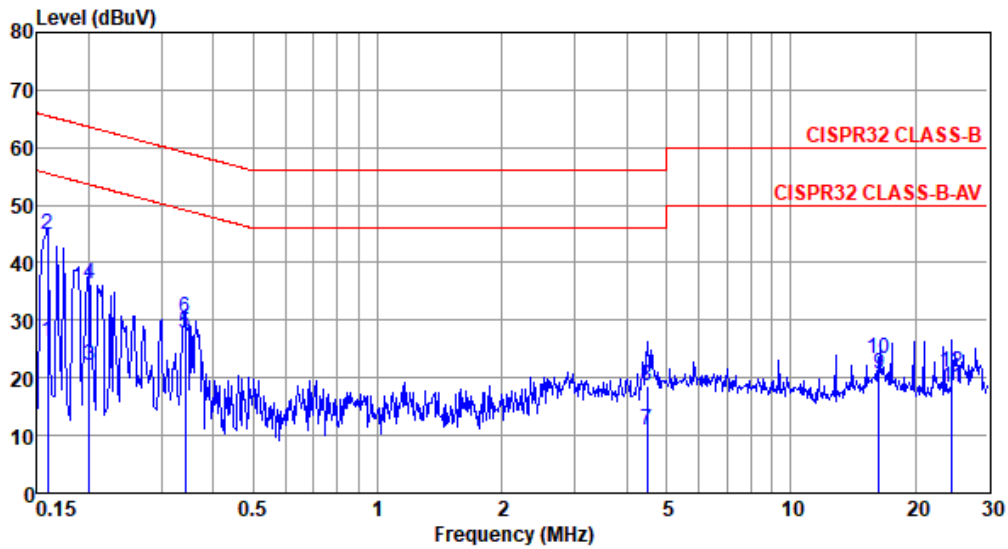

|    | Freq<br>MHz | Level<br>dBUV | Limit<br>Line<br>dBUV | Over<br>Limit<br>dB | Read<br>Level<br>dBUV | Factor<br>dB | Cable<br>loss<br>dB | Aux<br>dB | Remark  |
|----|-------------|---------------|-----------------------|---------------------|-----------------------|--------------|---------------------|-----------|---------|
| 1  | 0.159       | 26.40         | 55.52                 | -29.12              | 16.48                 | 9.68         | 0.06                | 0.18      | Average |
| 2* | 0.159       | 44.81         | 65.52                 | -20.71              | 34.89                 | 9.68         | 0.06                | 0.18      | QP      |
| 3  | 0.201       | 22.05         | 53.58                 | -31.53              | 12.12                 | 9.68         | 0.06                | 0.19      | Average |
| 4  | 0.201       | 36.22         | 63.58                 | -27.36              | 26.29                 | 9.68         | 0.06                | 0.19      | QP      |
| 5  | 0.343       | 27.60         | 49.13                 | -21.53              | 17.59                 | 9.67         | 0.06                | 0.28      | Average |
| 6  | 0.343       | 30.37         | 59.13                 | -28.76              | 20.36                 | 9.67         | 0.06                | 0.28      | QP      |
| 7  | 4.496       | 10.96         | 46.00                 | -35.04              | 0.64                  | 9.70         | 0.20                | 0.42      | Average |
| 8  | 4.496       | 18.69         | 56.00                 | -37.31              | 8.37                  | 9.70         | 0.20                | 0.42      | QP      |
| 9  | 16.372      | 20.61         | 50.00                 | -29.39              | 9.92                  | 9.73         | 0.46                | 0.50      | Average |
| 10 | 16.372      | 23.21         | 60.00                 | -36.79              | 12.52                 | 9.73         | 0.46                | 0.50      | QP      |
| 11 | 24.560      | 18.23         | 50.00                 | -31.77              | 7.36                  | 9.70         | 0.54                | 0.63      | Average |
| 12 | 24.560      | 20.86         | 60.00                 | -39.14              | 9.99                  | 9.70         | 0.54                | 0.63      | QP      |

Note 1: Level (dBUV) = Read Level (dBUV) + LISN Factor (dB) + Cable Loss (dB) + Aux (dB).  
 Note 2: Over Limit (dB) = Level (dBUV) - Limit Line (dBUV).



|             |              |                  |      |
|-------------|--------------|------------------|------|
| Modulation  | BT-LE(1Mbps) | Test Freq. (MHz) | 2402 |
| Power Phase | Neutral      |                  |      |

Test by : Joe Liao      Temperature: 22°C      Humidity: 63%

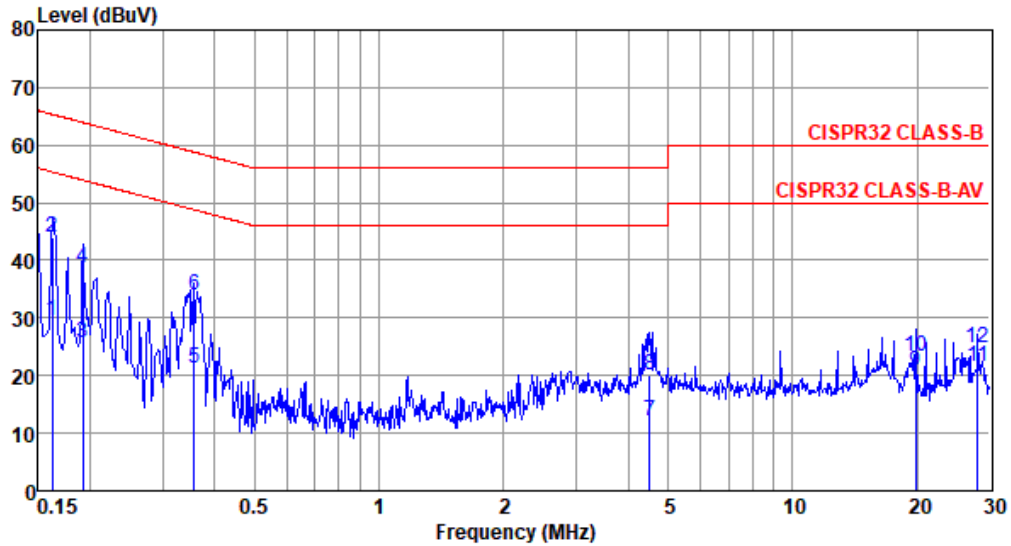

|    | Freq<br>MHz | Level<br>dBUV | Limit<br>Line<br>dBUV | Over<br>Limit<br>dB | Read<br>Level<br>dBUV | Factor<br>dB | Cable<br>loss<br>dB | Aux<br>dB | Remark  |
|----|-------------|---------------|-----------------------|---------------------|-----------------------|--------------|---------------------|-----------|---------|
| 1  | 0.162       | 29.48         | 55.34                 | -25.86              | 19.63                 | 9.61         | 0.06                | 0.18      | Average |
| 2* | 0.162       | 44.03         | 65.34                 | -21.31              | 34.18                 | 9.61         | 0.06                | 0.18      | QP      |
| 3  | 0.192       | 25.71         | 53.93                 | -28.22              | 15.85                 | 9.61         | 0.06                | 0.19      | Average |
| 4  | 0.192       | 38.63         | 63.93                 | -25.30              | 28.77                 | 9.61         | 0.06                | 0.19      | QP      |
| 5  | 0.358       | 21.30         | 48.78                 | -27.48              | 11.35                 | 9.61         | 0.06                | 0.28      | Average |
| 6  | 0.358       | 33.89         | 58.78                 | -24.89              | 23.94                 | 9.61         | 0.06                | 0.28      | QP      |
| 7  | 4.501       | 12.10         | 46.00                 | -33.90              | 1.83                  | 9.65         | 0.20                | 0.42      | Average |
| 8  | 4.501       | 20.19         | 56.00                 | -35.81              | 9.92                  | 9.65         | 0.20                | 0.42      | QP      |
| 9  | 19.880      | 20.73         | 50.00                 | -29.27              | 9.91                  | 9.79         | 0.51                | 0.52      | Average |
| 10 | 19.880      | 23.30         | 60.00                 | -36.70              | 12.48                 | 9.79         | 0.51                | 0.52      | QP      |
| 11 | 28.060      | 21.49         | 50.00                 | -28.51              | 10.38                 | 9.77         | 0.59                | 0.75      | Average |
| 12 | 28.060      | 24.75         | 60.00                 | -35.25              | 13.64                 | 9.77         | 0.59                | 0.75      | QP      |

Note 1: Level (dBUV) = Read Level (dBUV) + LISN Factor (dB) + Cable Loss (dB) + Aux (dB).  
 Note 2: Over Limit (dB) = Level (dBUV) - Limit Line (dBUV).