

FCC Test Report

FCC ID : SQG-IGUPCAT1
Equipment : Sentrius IG60 Category-1 LTE Module
Model No. : IGUP-CAT1
Brand Name : Laird
Applicant : Laird Connectivity, Inc.
Address : W66N220 Commerce Court, Cedarburg,
Wisconsin 53012, USA
Standard : 47 CFR FCC Part 27 Subpart L
Received Date : Aug. 19, 2019
Tested Date : Sep. 26, 2019

We, International Certification Corp., would like to declare that the tested sample has been evaluated and in compliance with the requirement of the above standards. The test results contained in this report refer exclusively to the product. It may be duplicated completely for legal use with the approval of the applicant. It shall not be reproduced except in full without the written approval of our laboratory.

Reviewed by:

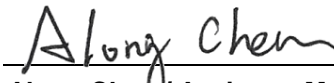

Along Chen / Assistant Manager

Approved by:



Gary Chang / Manager



Table of Contents

1	GENERAL DESCRIPTION	5
1.1	Information.....	5
1.2	Local Support Equipment List	7
1.3	Test Setup Chart	7
1.4	The Equipment List	8
1.5	Test Standards	8
1.6	Deviation from Test Standard and Measurement Procedure.....	8
1.7	Measurement Uncertainty	9
2	TEST CONFIGURATION	10
2.1	Testing Condition and Location Information.....	10
2.2	The Worst Test Modes and Channel Details	10
3	TEST RESULTS.....	11
3.1	Equivalent Isotropically Radiated Power	11
3.2	Radiated Emissions.....	17
4	TEST LABORATORY INFORMATION	30

Release Record

Report No.	Version	Description	Issued Date
FG981901P27L	Rev. 01	Initial issue	Nov. 01, 2019

Summary of Test Results

FCC Rules	Test Items	Measured	Result
2.1046 / 27.50(d)(4)	Equivalent Isotropically Radiated Power	Power[dBm]: 24.77	Pass
2.1053 / 27.53(h)	Radiated Emissions	Meet the requirement of limit	Pass
2.1051 / 27.53(h)	Conducted Emissions	Note	Pass
27.53(h)	Band Edge Measurement	Note	Pass
2.1049 / 27.53(h)	Occupied Bandwidth	Note	Pass
27.50(d)(5)	Peak to Average Ratio	Note	Pass
2.1055 / 27.54	Frequency Stability	Note	Pass

Note: Refers to test report of FCC ID: QIPPLS62-W. Test report no.: I17D00184-SRD05 / I17D00184-SRD06

Declaration of Conformity:

The test results with all measurement uncertainty excluded are presented in accordance with the regulation limits or requirements declared by manufacturers.

Comments and Explanations:

The declared of product specification for EUT presented in the report are provided by the manufacturer, and the manufacturer takes all the responsibilities for the accuracy of product specification.

1 General Description

1.1 Information

1.1.1 Specification of the Equipment under Test (EUT)

Operating Frequency	WCDMA Band IV LTE Band 4
Modulation	WCDMA/HSDPA/HSUPA/HSPA+: BPSK LTE: QPSK/16QAM

1.1.2 Antenna Details

Ant. No.	Type	Connector	Gain (dBi)	Remark
1	Dipole	SMA_MALE	2.2	--

1.1.3 EUT Operational Condition

Supply Voltage	Voltage Range: 4.75 VDC-5.25 VDC
-----------------------	----------------------------------

1.1.4 Operating Channel List

WCDMA BAND IV		
Channel Location	Channel	Frequency (MHz)
Low	1312	1712.4
Middle	1413	1732.6
High	1513	1752.6

LTE Band 4		
Channel Bandwidth (MHz)	Channel	Frequency (MHz)
1.4	19957	1710.7
1.4	20175	1732.5
1.4	20393	1754.3
3	19965	1711.5
3	20175	1732.5
3	20385	1753.5
5	19975	1712.5
5	20175	1732.5
5	20375	1752.5
10	20000	1715.0
10	20175	1732.5
10	20350	1750.0
15	20025	1717.5
15	20175	1732.5
15	20325	1747.5
20	20050	1720.0
20	20175	1732.5
20	20300	1745.0

1.2 Local Support Equipment List

Support Equipment List					
No.	Equipment	Brand	Model	S/N	Remarks
1	Adapter	Samsung	ETA-U90JWA	---	---
2	Fixture	---	---	---	Provided by applicant.

1.3 Test Setup Chart

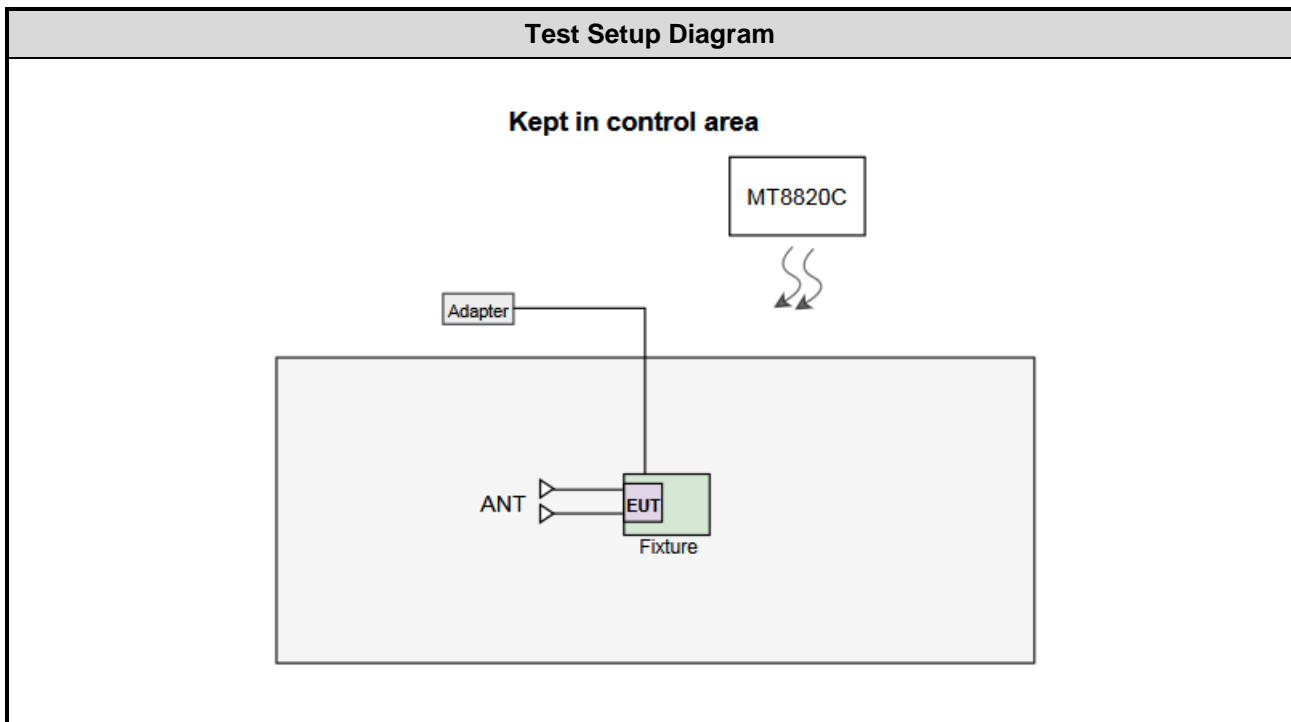

1.4 The Equipment List

Test Item	Radiated Emission				
Test Site	966 chamber1 / (03CH01-WS)				
Instrument	Manufacturer	Model No.	Serial No.	Calibration Date	Calibration Until
Spectrum Analyzer	R&S	FSV40	101498	Dec. 27, 2018	Dec. 26, 2019
Receiver	R&S	ESR3	101658	Dec. 11, 2018	Dec. 10, 2019
Bilog Antenna	SCHWARZBECK	VULB9168	VULB9168-522	Jul. 12, 2019	Jul. 11, 2020
Horn Antenna 1G-18G	SCHWARZBECK	BBHA 9120 D	BBHA 9120 D 1096	Dec. 18, 2018	Dec. 17, 2019
Horn Antenna 18G-40G	SCHWARZBECK	BBHA 9170	BBHA 9170517	Nov. 15, 2018	Nov. 14, 2019
Loop Antenna	R&S	HFH2-Z2	100330	Nov. 09, 2018	Nov. 08, 2019
Loop Antenna Cable	KOAX KABEL	101354-BW	101354-BW	Oct. 08, 2018	Oct. 07, 2019
Preamplifier	EMC	EMC02325	980225	Jul. 09, 2019	Jul. 08, 2020
Preamplifier	Agilent	83017A	MY39501308	Oct. 04, 2018	Oct. 03, 2019
Preamplifier	EMC	EMC184045B	980192	Aug. 01, 2019	Jul. 31, 2020
RF Cable	EMC	EMC104-SM-SM-80 00	181106	Oct. 08, 2018	Oct. 07, 2019
RF Cable	HUBER+SUHNER	SUCOFLEX104	MY16019/4	Oct. 08, 2018	Oct. 07, 2019
RF Cable	HUBER+SUHNER	SUCOFLEX104	MY16014/4	Oct. 08, 2018	Oct. 07, 2019
LF cable 1M	EMC	EMCCFD400-NM-N M-1000	160502	Oct. 08, 2018	Oct. 07, 2019
LF cable 3M	Woken	CFD400NL-LW	CFD400NL-001	Oct. 08, 2018	Oct. 07, 2019
LF cable 10M	Woken	CFD400NL-LW	CFD400NL-002	Oct. 08, 2018	Oct. 07, 2019
Measurement Software	AUDIX	e3	6.120210g	NA	NA

Note: Calibration Interval of instruments listed above is one year.

1.5 Test Standards

According to the specification of EUT, the EUT must comply with following standards.

47 CFR FCC Part 27 Subpart L

ANSI C63.4-2014

ANSI C63.26-2015

FCC KDB 971168 D01 Power Meas License Digital Systems v03r01

FCC KDB 971168 D02 Misc Rev Approv License Devices v02r01

FCC KDB 412172 D01 Determining ERP and EIRP v01r01

1.6 Deviation from Test Standard and Measurement Procedure

None

1.7 Measurement Uncertainty

ISO/IEC 17025 requires that an estimate of the measurement uncertainties associated with the emissions test results be included in the report. The measurement uncertainties given below are based on a 95% confidence level (based on a coverage factor (k=2)).

Measurement Uncertainty	
Parameters	Uncertainty
Radiated emission \leq 1GHz	± 3.41 dB
Radiated emission $>$ 1GHz	± 4.59 dB

2 Test Configuration

2.1 Testing Condition and Location Information

Test Item	Test Site	Ambient Condition	Tested By
Radiated Emissions	03CH01-WS	22°C / 64-65%	Aska Huang

- FCC Designation No.: TW2732
- FCC site registration No.: 181692
- ISED#: 10807A
- CAB identifier: TW2732

2.2 The Worst Test Modes and Channel Details

WCDMA BAND IV		
Test item	Mode	Test channel
E.I.R.P	WCDMA BAND IV	1312, 1413, 1513
Radiated Emission ≤ 1GHz	WCDMA BAND IV	1513
Radiated Emission > 1GHz	WCDMA BAND IV	1312, 1413, 1513

LTE Band 4			
Test item	Channel Bandwidth	Modulation	Test channel
E.I.R.P	1.4 MHz	QPSK / 16QAM	19957 / 20175 / 20393
	3 MHz	QPSK / 16QAM	19965 / 20175 / 20385
	5 MHz	QPSK / 16QAM	19975 / 20175 / 20375
	10 MHz	QPSK / 16QAM	20000 / 20175 / 20350
	15 MHz	QPSK / 16QAM	20025 / 20175 / 20325
	20 MHz	QPSK / 16QAM	20050 / 20175 / 20300
Radiated Emission ≤ 1GHz	1.4 MHz	QPSK	19957
	3 MHz	QPSK	19965
	5 MHz	QPSK	19975
	10 MHz	QPSK	20000
	15 MHz	QPSK	20025
	20 MHz	QPSK	20050
Radiated Emission > 1GHz	1.4 MHz	QPSK	19957 / 20175 / 20393
	3 MHz	QPSK	19965 / 20175 / 20385
	5 MHz	QPSK	19975 / 20175 / 20375
	10 MHz	QPSK	20000 / 20175 / 20350
	15 MHz	QPSK	20025 / 20175 / 20325
	20 MHz	QPSK	20050 / 20175 / 20300

3 Test Results

3.1 Equivalent Isotropically Radiated Power

3.1.1 Limit of Equivalent Isotropically Radiated Power

Mobile and portable stations are limited to 1 watts EIRP.

3.1.2 Test Procedures

For Conducted power measurement:

1. The EUT links up with simulator and is set to maximum output power level at low / middle / high channel.
2. Measure the output power of low / middle / high channel of the EUT.

For EIRP measurement:

EIPR can be calculated by below formula from KDB 412172 D01.

1. $EIRP = P_T + G_T - L_C$

P_T = transmitter output power, in dBm.

G_T = gain of the transmitting antenna, in dBi (EIRP).

L_C = signal attenuation in the connecting cable between the transmitter and antenna, in dB.

3.1.3 Test Setup

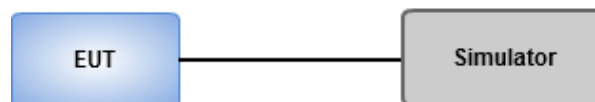

3.1.4 Test Result of Equivalent Isotropically Radiated Power (dBm)

Mode	WCDMA BAND IV					
Channel	Frequency (MHz)	Conducted Output Power (dBm)	Max Antenna Gain (dBi)	EIRP (dBm)	EIRP (W)	Limit (W)
1312	1712.4	22.32	2.2	24.52	0.283	1
1413	1732.6	22.46	2.2	24.66	0.292	1
1513	1752.6	22.57	2.2	24.77	0.300	1

Note1: EIRP = Conducted Output Power + Antenna Gain.

Note2: Conducted power refers to test report of FCC ID: QIPPLS62-W. Test report no.: I17D00184-SRD05

Bandwidth	RB size/offset	Freq. (MHz)	Power (dBm)			Antenna Gain (dBi)	E.I.R.P Power (dBm)	E.I.R.P Power (W)	E.I.R.P Limit (W)
			QPSK	16QAM	max Power				
1.4MHz	1 RB high	1754.3	21.32	20.53	21.32	2.2	23.52	0.225	1
		1732.5	21.55	20.62	21.55	2.2	23.75	0.237	1
		1710.7	21.78	20.88	21.78	2.2	23.98	0.250	1
	1 RB low	1754.3	21.38	20.55	21.38	2.2	23.58	0.228	1
		1732.5	21.63	20.64	21.63	2.2	23.83	0.242	1
		1710.7	21.83	20.9	21.83	2.2	24.03	0.253	1
	50% RB mid	1754.3	21.44	21.42	21.44	2.2	23.64	0.231	1
		1732.5	21.55	21.55	21.55	2.2	23.75	0.237	1
		1710.7	21.77	21.76	21.77	2.2	23.97	0.249	1
	100% RB	1754.3	20.36	19.42	20.36	2.2	22.56	0.180	1
		1732.5	20.51	19.56	20.51	2.2	22.71	0.187	1
		1710.7	20.73	19.73	20.73	2.2	22.93	0.196	1
3MHz	1 RB high	1753.5	21.39	20.55	21.39	2.2	23.59	0.229	1
		1732.5	21.44	20.87	21.44	2.2	23.64	0.231	1
		1711.5	21.69	20.86	21.69	2.2	23.89	0.245	1
	1 RB low	1753.5	21.45	20.65	21.45	2.2	23.65	0.232	1
		1732.5	21.56	21.02	21.56	2.2	23.76	0.238	1
		1711.5	21.79	20.93	21.79	2.2	23.99	0.251	1
	50% RB mid	1753.5	20.4	19.42	20.4	2.2	22.6	0.182	1
		1732.5	20.47	19.53	20.47	2.2	22.67	0.185	1
		1711.5	20.72	19.78	20.72	2.2	22.92	0.196	1
	100% RB	1753.5	20.44	19.44	20.44	2.2	22.64	0.184	1
		1732.5	20.49	19.58	20.49	2.2	22.69	0.186	1
		1711.5	20.74	19.77	20.74	2.2	22.94	0.197	1

Note1: EIRP = Conducted Output Power + Antenna Gain.

Note2: Conducted power refers to test report of FCC ID: QIPPLS62-W. Test report no.: I17D00184-SRD06

Bandwidth	RB size/offset	Freq. (MHz)	Power (dBm)			Antenna Gain (dBi)	E.I.R.P Power (dBm)	E.I.R.P Power (W)	E.I.R.P Limit (W)
			QPSK	16QAM	max Power				
5MHz	1 RB high	1752.5	21.3	20.54	21.3	2.2	23.5	0.224	1
		1732.5	21.42	20.29	21.42	2.2	23.62	0.230	1
		1712.5	21.59	20.86	21.59	2.2	23.79	0.239	1
	1 RB low	1752.5	21.53	20.67	21.53	2.2	23.73	0.236	1
		1732.5	21.59	20.45	21.59	2.2	23.79	0.239	1
		1712.5	21.82	20.96	21.82	2.2	24.02	0.252	1
	50% RB mid	1752.5	20.4	20.4	20.4	2.2	22.6	0.182	1
		1732.5	20.44	20.48	20.48	2.2	22.68	0.185	1
		1712.5	20.7	20.7	20.7	2.2	22.9	0.195	1
	100% RB	1752.5	20.36	19.43	20.36	2.2	22.56	0.180	1
		1732.5	20.54	19.58	20.54	2.2	22.74	0.188	1
		1712.5	20.72	19.77	20.72	2.2	22.92	0.196	1
10MHz	1 RB high	1750	21.43	20.6	21.43	2.2	23.63	0.231	1
		1732.5	21.24	20.81	21.24	2.2	23.44	0.221	1
		1715	21.71	20.88	21.71	2.2	23.91	0.246	1
	1 RB low	1750	21.76	20.88	21.76	2.2	23.96	0.249	1
		1732.5	21.69	21.2	21.69	2.2	23.89	0.245	1
		1715	22.02	21.2	22.02	2.2	24.22	0.264	1
	50% RB mid	1750	20.38	20.38	20.38	2.2	22.58	0.181	1
		1732.5	20.39	20.39	20.39	2.2	22.59	0.182	1
		1715	20.69	20.69	20.69	2.2	22.89	0.195	1
	100% RB	1750	20.47	19.48	20.47	2.2	22.67	0.185	1
		1732.5	20.54	19.56	20.54	2.2	22.74	0.188	1
		1715	20.79	19.84	20.79	2.2	22.99	0.199	1

Note1: EIRP = Conducted Output Power + Antenna Gain.

Note2: Conducted power refers to test report of FCC ID: QIPPLS62-W. Test report no.: I17D00184-SRD06

Bandwidth	RB size/offset	Freq. (MHz)	Power (dBm)			Antenna Gain (dBi)	E.I.R.P Power (dBm)	E.I.R.P Power (W)	E.I.R.P Limit (W)
			QPSK	16QAM	max Power				
15MHz	1 RB high	1747.5	21.53	20.7	21.53	2.2	23.73	0.236	1
		1732.5	21.46	21.08	21.46	2.2	23.66	0.232	1
		1717.5	21.78	20.94	21.78	2.2	23.98	0.250	1
	1 RB low	1747.5	22.02	21.18	22.02	2.2	24.22	0.264	1
		1732.5	22.09	21.65	22.09	2.2	24.29	0.269	1
		1717.5	22.33	21.48	22.33	2.2	24.53	0.284	1
	50% RB mid	1747.5	20.51	20.52	20.52	2.2	22.72	0.187	1
		1732.5	20.51	20.51	20.51	2.2	22.71	0.187	1
		1717.5	20.78	20.79	20.79	2.2	22.99	0.199	1
	100% RB	1747.5	20.61	19.61	20.61	2.2	22.81	0.191	1
		1732.5	20.67	19.69	20.67	2.2	22.87	0.194	1
		1717.5	20.85	19.91	20.85	2.2	23.05	0.202	1
20MHz	1 RB high	1745.0	21.22	20.47	21.22	2.2	23.42	0.220	1
		1732.5	21.33	20.47	21.33	2.2	23.53	0.225	1
		1720.0	21.47	20.76	21.47	2.2	23.67	0.233	1
	1 RB low	1745.0	21.86	21.17	21.86	2.2	24.06	0.255	1
		1732.5	22.20	21.33	22.20	2.2	24.40	0.275	1
		1720.0	22.23	21.47	22.23	2.2	24.43	0.277	1
	50% RB mid	1745.0	20.39	20.40	20.40	2.2	22.60	0.182	1
		1732.5	20.48	20.49	20.49	2.2	22.69	0.186	1
		1720.0	20.68	20.69	20.69	2.2	22.89	0.195	1
	100% RB	1745.0	20.57	19.58	20.57	2.2	22.77	0.189	1
		1732.5	20.68	19.70	20.68	2.2	22.88	0.194	1
		1720.0	20.87	19.82	20.87	2.2	23.07	0.203	1

Note1: EIRP = Conducted Output Power + Antenna Gain.

Note2: Conducted power refers to test report of FCC ID: QIPPLS62-W. Test report no.: I17D00184-SRD06

3.1.5 Verification of Conducted Output Power

Mode	WCDMA BAND IV		
Channel	Frequency (MHz)	Conducted Output Power (dBm)	
		Original	Verified
1312	1712.4	22.32	23.14
1413	1732.6	22.46	23.31
1513	1752.6	22.57	23.04

Mode	LTE					
Bandwidth	RB size/offset	Freq. (MHz)	Conducted Output Power (dBm)			
			QPSK		16QAM	
			Original	Verified	Original	Verified
15MHz	1 RB high	1747.5	21.53	22.49	20.70	21.16
		1732.5	21.46	22.43	21.08	21.67
		1717.5	21.78	22.67	20.94	21.83
	1 RB low	1747.5	22.02	22.78	21.18	21.85
		1732.5	22.09	22.89	21.65	22.15
		1717.5	22.33	23.14	21.48	22.46
	50% RB mid	1747.5	20.51	21.6	20.52	20.88
		1732.5	20.51	21.61	20.51	20.86
		1717.5	20.78	21.93	20.79	20.94
	100% RB	1747.5	20.61	21.52	19.61	20.41
		1732.5	20.67	21.62	19.69	20.43
		1717.5	20.85	21.79	19.91	20.73

3.2 Radiated Emissions

3.2.1 Limit of Radiated Emissions

The power of any emission outside of the authorized operating frequency ranges must be attenuated below the transmitting power (P) by a factor of at least $43 + 10 \log(P)$ dB equal to -13 dBm.

3.2.2 Test Procedures

1. Measurement is made at a semi-anechoic chamber that incorporates a turntable allowing a EUT rotation of 360°. A continuously-rotating, remotely-controlled turntable is installed at the test site to support the EUT and facilitate determination of the direction of maximum radiation for each EUT emission frequency. For emissions testing at or below 1 GHz, the table height is 80 cm above the reference ground plane. For emission measurements above 1 GHz, the table height is 1.5 m.
2. Measurement is made with the antenna positioned in both the horizontal and vertical planes of polarization. The measurement antenna is varied in height (1m ~ 4m) above the reference ground plane to obtain the maximum signal strength. Distance between EUT and antenna is 3 m.
3. This investigation is performed with the EUT rotated 360°, the antenna height scanned between 1 m and 4 m, and the antenna rotated to repeat the measurements for both the horizontal and vertical antenna polarizations.
4. After finding the max radiated emission, substitution method will be used for getting effective radiated power. EUT will be removed and substitution antenna will be placed at same position. Signal generator will output CW signal to substitution antenna through a RF cable. Rotate turntable and move antenna to find maximum radiated emission. Adjust output power of signal generator to let the maximum radiated emission is same as step 3. Record the output power level.
5. E.I.R.P = output power of step 4 + gain of substitution antenna – cable loss of RF cable.

3.2.3 Test Setup

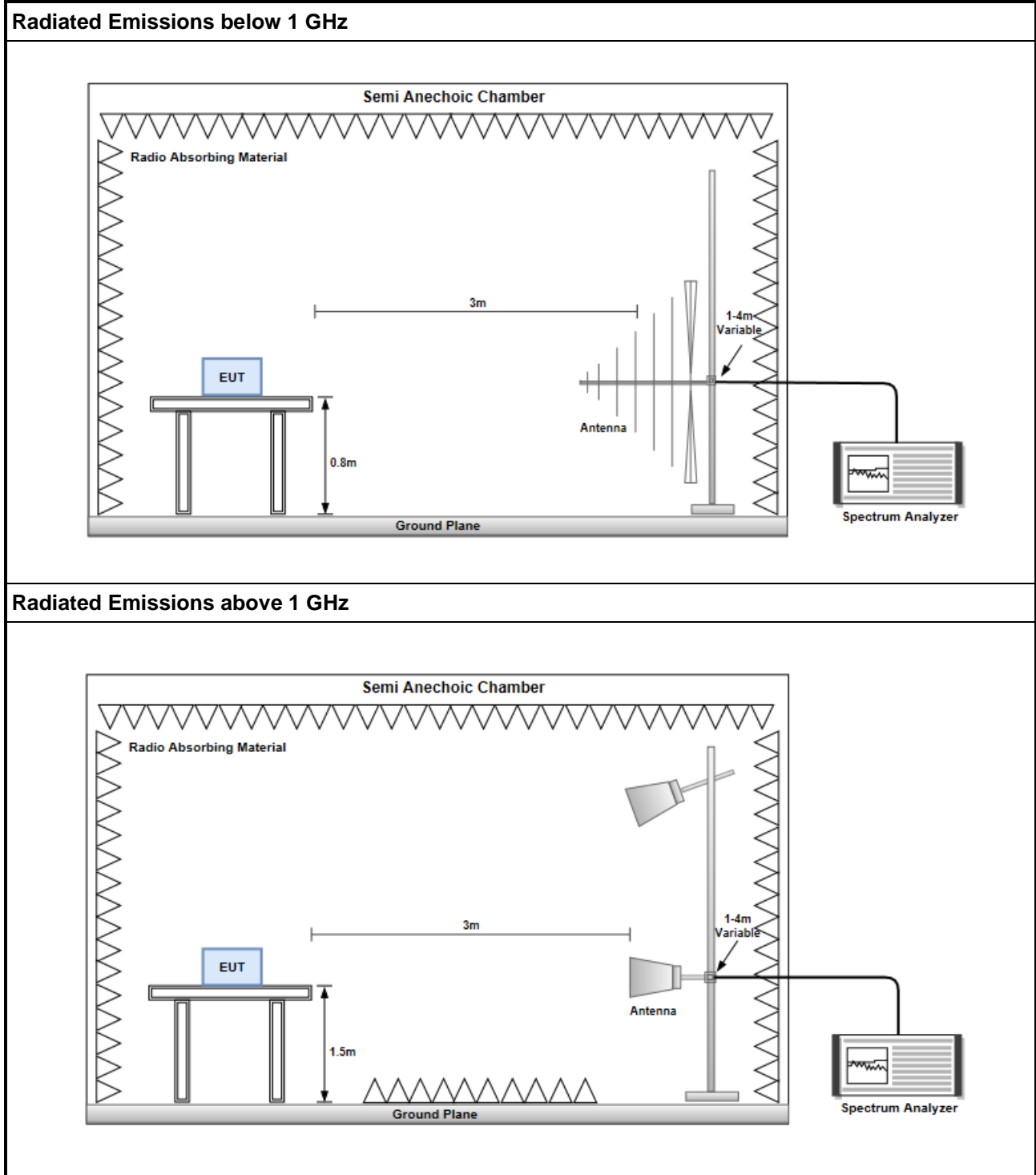

3.2.4 Test Result of Radiated Emissions below 1GHz

Mode	WCDMA, Channel: 1513						
Frequency (MHz)	Antenna Polarity	E.I.R.P (dBm)	Limit (dBm)	Margin (dB)	S.A Reading (dBm)	S.G Power Vaule (dBm)	Correction Factor (dB)
64.96	H	-57.83	-13	-44.83	-50.23	-50.74	-7.09
120.45	H	-45.36	-13	-32.36	-35.17	-44.64	-0.72
142.71	H	-55.46	-13	-42.46	-46.66	-54.18	-1.28
180.27	H	-64.08	-13	-51.08	-53.69	-66.23	2.15
316.35	H	-62.93	-13	-49.93	-54.22	-67.2	4.27
340.18	H	-60.43	-13	-47.43	-53.03	-64.81	4.38
32.75	V	-53.16	-13	-40.16	-42.07	-39.54	-13.62
41.88	V	-54.26	-13	-41.26	-44.29	-42.23	-12.03
108.54	V	-40.52	-13	-27.52	-31.31	-40.37	-0.15
146.67	V	-56.94	-13	-43.94	-50.17	-55.75	-1.19
278.23	V	-62.51	-13	-49.51	-56.48	-66.78	4.27
309.71	V	-58.72	-13	-45.72	-52.54	-62.96	4.24

Note: EIRP = S.G Power value + Correction factor.

Mode							
LTE Band 4, QPSK, CB:1.4 MHz, 1 RB Offset 0, Channel: 19957							
Frequency (MHz)	Antenna Polarity	E.I.R.P (dBm)	Limit (dBm)	Margin (dB)	S.A Reading (dBm)	S.G Power Vaule (dBm)	Correction Factor (dB)
30.00	H	-61.60	-13.00	-48.60	-71.46	-41.63	-19.97
64.92	H	-69.29	-13.00	-56.29	-69.86	-56.73	-12.56
74.62	H	-71.38	-13.00	-58.38	-70.31	-62.11	-9.27
90.14	H	-66.05	-13.00	-53.05	-64.60	-60.92	-5.13
98.87	H	-69.91	-13.00	-56.91	-68.75	-64.75	-5.16
953.44	H	-60.57	-13.00	-47.57	-69.98	-57.62	-2.95
30.97	V	-67.20	-13.00	-54.20	-67.26	-47.50	-19.70
57.16	V	-69.94	-13.00	-56.94	-69.35	-55.25	-14.69
90.14	V	-63.27	-13.00	-50.27	-63.42	-58.14	-5.13
439.34	V	-69.96	-13.00	-56.96	-72.63	-68.75	-1.21
932.10	V	-60.85	-13.00	-47.85	-72.36	-58.01	-2.84
953.44	V	-57.20	-13.00	-44.20	-68.74	-54.25	-2.95

Note: EIRP = S.G Power value + Correction factor.

Mode							
LTE Band 4, QPSK, CB:3 MHz, 1 RB Offset 0, Channel: 19965							
Frequency (MHz)	Antenna Polarity	E.I.R.P (dBm)	Limit (dBm)	Margin (dB)	S.A Reading (dBm)	S.G Power Vaule (dBm)	Correction Factor (dB)
30.00	H	-66.26	-13.00	-53.26	-76.12	-46.29	-19.97
52.31	H	-69.97	-13.00	-56.97	-73.26	-54.27	-15.70
90.14	H	-66.12	-13.00	-53.12	-64.67	-60.99	-5.13
171.62	H	-75.10	-13.00	-62.10	-74.32	-69.76	-5.34
286.08	H	-73.75	-13.00	-60.75	-71.80	-72.28	-1.47
953.44	H	-60.54	-13.00	-47.54	-69.95	-57.59	-2.95
32.91	V	-61.01	-13.00	-48.01	-59.02	-41.86	-19.15
90.14	V	-63.59	-13.00	-50.59	-63.74	-58.46	-5.13
95.96	V	-70.18	-13.00	-57.18	-70.73	-65.30	-4.88
156.10	V	-72.28	-13.00	-59.28	-74.90	-65.59	-6.69
439.34	V	-70.54	-13.00	-57.54	-73.21	-69.33	-1.21
953.44	V	-57.57	-13.00	-44.57	-69.11	-54.62	-2.95

Note: EIRP = S.G Power value + Correction factor.

Mode							
LTE Band 4, QPSK, CB:5 MHz, 1 RB Offset 0, Channel: 19975							
Frequency (MHz)	Antenna Polarity	E.I.R.P (dBm)	Limit (dBm)	Margin (dB)	S.A Reading (dBm)	S.G Power Vaule (dBm)	Correction Factor (dB)
30.00	H	-64.06	-13.00	-51.06	-73.92	-44.09	-19.97
52.31	H	-68.52	-13.00	-55.52	-71.81	-52.82	-15.70
90.14	H	-66.20	-13.00	-53.20	-64.75	-61.07	-5.13
98.87	H	-70.56	-13.00	-57.56	-69.40	-65.40	-5.16
173.56	H	-74.84	-13.00	-61.84	-74.05	-69.71	-5.13
953.44	H	-61.33	-13.00	-48.33	-70.74	-58.38	-2.95
32.91	V	-61.15	-13.00	-48.15	-33.09	-42.00	-19.15
90.14	V	-63.52	-13.00	-50.52	-35.27	-58.39	-5.13
95.96	V	-70.06	-13.00	-57.06	-41.78	-65.18	-4.88
156.10	V	-72.11	-13.00	-59.11	-43.73	-65.42	-6.69
439.34	V	-70.64	-13.00	-57.64	-42.47	-69.43	-1.21
953.44	V	-57.60	-13.00	-44.60	-30.05	-54.65	-2.95

Note: EIRP = S.G Power value + Correction factor.

Mode							
LTE Band 4, QPSK, CB:10 MHz, 1 RB Offset 0, Channel: 20000							
Frequency (MHz)	Antenna Polarity	E.I.R.P (dBm)	Limit (dBm)	Margin (dB)	S.A Reading (dBm)	S.G Power Vaule (dBm)	Correction Factor (dB)
30.97	H	-64.43	-13.00	-51.43	-73.95	-44.73	-19.70
64.92	H	-69.64	-13.00	-56.64	-70.21	-57.08	-12.56
90.14	H	-66.09	-13.00	-53.09	-64.64	-60.96	-5.13
171.62	H	-74.72	-13.00	-61.72	-73.94	-69.38	-5.34
258.92	H	-73.32	-13.00	-60.32	-70.40	-71.84	-1.48
953.44	H	-60.22	-13.00	-47.22	-69.63	-57.27	-2.95
30.97	V	-67.29	-13.00	-54.29	-39.23	-47.59	-19.70
57.16	V	-70.12	-13.00	-57.12	-42.02	-55.43	-14.69
90.14	V	-63.37	-13.00	-50.37	-35.12	-58.24	-5.13
439.34	V	-69.96	-13.00	-56.96	-72.63	-68.75	-1.21
932.10	V	-60.64	-13.00	-47.64	-33.07	-57.80	-2.84
953.44	V	-57.36	-13.00	-44.36	-29.81	-54.41	-2.95

Note: EIRP = S.G Power value + Correction factor.

Mode	LTE Band 4, QPSK, CB:15 MHz, 1 RB Offset 0, Channel: 20025						
Frequency (MHz)	Antenna Polarity	E.I.R.P (dBm)	Limit (dBm)	Margin (dB)	S.A Reading (dBm)	S.G Power Vaule (dBm)	Correction Factor (dB)
30.97	H	-51.43	-13.00	-38.43	-73.95	-31.73	-19.70
64.92	H	-56.64	-13.00	-43.64	-70.21	-44.08	-12.56
90.14	H	-53.09	-13.00	-40.09	-64.64	-47.96	-5.13
171.62	H	-61.72	-13.00	-48.72	-73.94	-56.38	-5.34
258.92	H	-60.22	-13.00	-47.22	-70.30	-58.74	-1.48
953.44	H	-47.14	-13.00	-34.14	-69.55	-44.19	-2.95
30.97	V	-67.33	-13.00	-54.33	-67.39	-47.63	-19.70
57.16	V	-70.24	-13.00	-57.24	-69.65	-55.55	-14.69
90.14	V	-63.30	-13.00	-50.30	-63.45	-58.17	-5.13
739.34	V	-70.06	-13.00	-57.06	-72.73	-68.85	-1.21
932.10	V	-60.54	-13.00	-47.54	-72.05	-57.70	-2.84
953.44	V	-57.31	-13.00	-44.31	-68.85	-54.36	-2.95

Note: EIRP = S.G Power value + Correction factor.

Mode	LTE Band 4, QPSK, CB:20 MHz, 1 RB Offset 0, Channel: 20050						
Frequency (MHz)	Antenna Polarity	E.I.R.P (dBm)	Limit (dBm)	Margin (dB)	S.A Reading (dBm)	S.G Power Vaule (dBm)	Correction Factor (dB)
30.00	H	-65.85	-13.00	-52.85	-75.71	-45.88	-19.97
63.95	H	-70.65	-13.00	-57.65	-71.33	-57.80	-12.85
90.14	H	-65.80	-13.00	-52.80	-64.35	-60.67	-5.13
98.87	H	-70.75	-13.00	-57.75	-69.59	-65.59	-5.16
939.86	H	-62.24	-13.00	-49.24	-71.56	-59.34	-2.90
953.44	H	-62.05	-13.00	-49.05	-71.46	-59.10	-2.95
32.91	V	-60.95	-13.00	-47.95	-58.95	-41.80	-19.15
90.14	V	-63.47	-13.00	-50.47	-63.62	-58.34	-5.13
95.96	V	-70.08	-13.00	-57.08	-70.63	-65.20	-4.88
156.10	V	-72.11	-13.00	-59.11	-74.73	-65.42	-6.69
439.34	V	-70.48	-13.00	-57.48	-73.15	-69.27	-1.21
953.44	V	-57.43	-13.00	-44.43	-68.97	-54.48	-2.95

Note: EIRP = S.G Power value + Correction factor.

3.2.5 Test Result of Radiated Emissions above 1GHz

Mode		WCDMA, Channel: 1312					
Frequency (MHz)	Antenna Polarity	E.I.R.P (dBm)	Limit (dBm)	Margin (dB)	S.A Reading (dBm)	S.G Power Vaule (dBm)	Correction Factor (dB)
3424.80	H	-51.14	-13.00	-38.14	-62.15	-58.56	7.42
5137.20	H	-44.82	-13.00	-31.82	-61.49	-51.47	6.65
6849.60	H	-45.50	-13.00	-32.50	-64.56	-50.49	4.99
3424.80	V	-46.25	-13.00	-33.25	-57.26	-53.67	7.42
5137.20	V	-41.13	-13.00	-28.13	-57.69	-47.78	6.65
6849.60	V	-44.88	-13.00	-31.88	-64.10	-49.87	4.99

Mode		WCDMA, Channel: 1413					
Frequency (MHz)	Antenna Polarity	E.I.R.P (dBm)	Limit (dBm)	Margin (dB)	S.A Reading (dBm)	S.G Power Vaule (dBm)	Correction Factor (dB)
3465.20	H	-48.63	-13.00	-35.63	-60.13	-55.95	7.32
5197.80	H	-46.00	-13.00	-33.00	-62.58	-52.71	6.71
6930.40	H	-45.46	-13.00	-32.46	-64.86	-50.23	4.77
3465.20	V	-43.64	-13.00	-30.64	-55.09	-50.96	7.32
5197.80	V	-41.31	-13.00	-28.31	-57.82	-48.02	6.71
6930.40	V	-44.40	-13.00	-31.40	-64.24	-49.17	4.77

Mode		WCDMA, Channel : 1513					
Frequency (MHz)	Antenna Polarity.	E.I.R.P (dBm)	Limit (dBm)	Margin (dB)	S.A Reading (dBm)	S.G Power Vaule (dBm)	Correction Factor (dB)
3505.20	H	-45.27	-13.00	-32.27	-57.26	-52.49	7.22
5257.80	H	-46.58	-13.00	-33.58	-63.12	-53.32	6.74
7010.40	H	-44.84	-13.00	-31.84	-64.55	-49.37	4.53
3505.20	V	-40.34	-13.00	-27.34	-52.23	-47.56	7.22
5257.80	V	-40.93	-13.00	-27.93	-57.45	-47.67	6.74
7010.40	V	-44.10	-13.00	-31.10	-64.53	-48.63	4.53

Note: EIRP = S.G Power value + Correction factor.

Mode							
LTE Band 4, QPSK, CB:1.4 MHz, 1 RB Offset 0, Channel: 19957							
Frequency (MHz)	Antenna Polarity	E.I.R.P (dBm)	Limit (dBm)	Margin (dB)	S.A Reading (dBm)	S.G Power Vaule (dBm)	Correction Factor (dB)
3420.40	H	-44.50	-13.00	-31.50	-55.46	-51.93	7.43
5130.60	H	-42.54	-13.00	-29.54	-59.23	-49.18	6.64
6840.80	H	-45.98	-13.00	-32.98	-65.01	-50.99	5.01
3420.40	V	-38.43	-13.00	-25.43	-49.39	-45.86	7.43
5130.60	V	-37.70	-13.00	-24.70	-54.27	-44.34	6.64
6840.80	V	-46.29	-13.00	-33.29	-65.45	-51.30	5.01

Mode							
LTE Band 4, QPSK, CB:1.4 MHz, 1 RB Offset 0, Channel: 20175							
Frequency (MHz)	Antenna Polarity	E.I.R.P (dBm)	Limit (dBm)	Margin (dB)	S.A Reading (dBm)	S.G Power Vaule (dBm)	Correction Factor (dB)
3464.00	H	-42.17	-13.00	-29.17	-53.66	-49.49	7.32
5196.00	H	-41.57	-13.00	-28.57	-58.15	-48.28	6.71
6928.00	H	-45.72	-13.00	-32.72	-65.12	-50.49	4.77
3464.00	V	-35.12	-13.00	-22.12	-46.56	-42.44	7.32
5196.00	V	-36.91	-13.00	-23.91	-53.42	-43.62	6.71
6928.00	V	-45.69	-13.00	-32.69	-65.53	-50.46	4.77

Mode							
LTE Band 4, QPSK, CB:1.4 MHz, 1 RB Offset 0, Channel: 20393							
Frequency (MHz)	Antenna Polarity	E.I.R.P (dBm)	Limit (dBm)	Margin (dB)	S.A Reading (dBm)	S.G Power Vaule (dBm)	Correction Factor (dB)
3507.60	H	-38.53	-13.00	-25.53	-50.54	-45.75	7.22
5261.40	H	-40.48	-13.00	-27.48	-57.02	-47.22	6.74
7015.20	H	-45.45	-13.00	-32.45	-65.15	-49.96	4.51
3507.60	V	-31.02	-13.00	-18.02	-42.93	-38.24	7.22
5261.40	V	-35.79	-13.00	-22.79	-52.31	-42.53	6.74
7015.20	V	-44.99	-13.00	-31.99	-65.43	-49.50	4.51

Note: EIRP = S.G Power value + Correction factor.

Mode							
LTE Band 4, QPSK, CB:3 MHz, 1 RB Offset 0, Channel: 19965							
Frequency (MHz)	Antenna Polarity	E.I.R.P (dBm)	Limit (dBm)	Margin (dB)	S.A Reading (dBm)	S.G Power Vaule (dBm)	Correction Factor (dB)
3420.80	H	-44.64	-13.00	-31.64	-55.60	-52.07	7.43
5131.20	H	-42.68	-13.00	-29.68	-59.36	-49.32	6.64
6841.60	H	-46.04	-13.00	-33.04	-65.07	-51.05	5.01
3420.80	V	-38.27	-13.00	-25.27	-49.24	-45.70	7.43
5131.20	V	-37.77	-13.00	-24.77	-54.34	-44.41	6.64
6841.60	V	-46.13	-13.00	-33.13	-65.30	-51.14	5.01

Mode							
LTE Band 4, QPSK, CB:3 MHz, 1 RB Offset 0, Channel: 20175							
Frequency (MHz)	Antenna Polarity	E.I.R.P (dBm)	Limit (dBm)	Margin (dB)	S.A Reading (dBm)	S.G Power Vaule (dBm)	Correction Factor (dB)
3462.80	H	-42.09	-13.00	-29.09	-53.56	-49.42	7.33
5194.20	H	-41.71	-13.00	-28.71	-58.29	-48.41	6.70
6925.60	H	-45.82	-13.00	-32.82	-65.20	-50.60	4.78
3462.80	V	-35.37	-13.00	-22.37	-46.79	-42.70	7.33
5194.20	V	-37.05	-13.00	-24.05	-53.57	-43.75	6.70
6925.60	V	-45.61	-13.00	-32.61	-65.42	-50.39	4.78

Mode							
LTE Band 4, QPSK, CB:3 MHz, 1 RB Offset 0, Channel: 20385							
Frequency (MHz)	Antenna Polarity	E.I.R.P (dBm)	Limit (dBm)	Margin (dB)	S.A Reading (dBm)	S.G Power Vaule (dBm)	Correction Factor (dB)
3504.80	H	-38.66	-13.00	-25.66	-50.64	-45.88	7.22
5257.20	H	-40.75	-13.00	-27.75	-57.29	-47.49	6.74
7009.60	H	-45.53	-13.00	-32.53	-65.23	-50.06	4.53
3504.80	V	-32.21	-13.00	-19.21	-43.09	-39.43	7.22
5257.20	V	-35.77	-13.00	-22.77	-52.29	-42.51	6.74
7009.60	V	-44.89	-13.00	-31.89	-65.31	-49.42	4.53

Note: EIRP = S.G Power value + Correction factor.

Mode							
LTE Band 4, QPSK, CB:5 MHz, 1 RB Offset 0, Channel: 19975							
Frequency (MHz)	Antenna Polarity	E.I.R.P (dBm)	Limit (dBm)	Margin (dB)	S.A Reading (dBm)	S.G Power Vaule (dBm)	Correction Factor (dB)
3420.60	H	-44.60	-13.00	-31.60	-55.56	-52.03	7.43
5130.90	H	-42.48	-13.00	-29.48	-59.16	-49.12	6.64
6841.20	H	-46.14	-13.00	-33.14	-65.17	-51.15	5.01
3420.60	V	-38.32	-13.00	-25.32	-49.28	-45.75	7.43
5130.90	V	-38.00	-13.00	-25.00	-54.57	-44.64	6.64
6841.20	V	-46.02	-13.00	-33.02	-65.18	-51.03	5.01

Mode							
LTE Band 4, QPSK, CB:5 MHz, 1 RB Offset 0, Channel: 20175							
Frequency (MHz)	Antenna Polarity	E.I.R.P (dBm)	Limit (dBm)	Margin (dB)	S.A Reading (dBm)	S.G Power Vaule (dBm)	Correction Factor (dB)
3460.60	H	-42.05	-13.00	-29.05	-53.49	-49.38	7.33
5190.90	H	-41.75	-13.00	-28.75	-58.34	-48.45	6.70
6921.20	H	-45.89	-13.00	-32.89	-65.26	-50.68	4.79
3460.60	V	-35.03	-13.00	-22.03	-46.43	-42.36	7.33
5190.90	V	-37.05	-13.00	-24.05	-53.57	-43.75	6.70
6921.20	V	-45.51	-13.00	-32.51	-65.29	-50.30	4.79

Mode							
LTE Band 4, QPSK, CB:5 MHz, 1 RB Offset 0, Channel: 20375							
Frequency (MHz)	Antenna Polarity	E.I.R.P (dBm)	Limit (dBm)	Margin (dB)	S.A Reading (dBm)	S.G Power Vaule (dBm)	Correction Factor (dB)
3500.60	H	-38.13	-13.00	-25.13	-50.06	-45.36	7.23
5250.90	H	-40.67	-13.00	-27.67	-57.22	-47.41	6.74
7001.20	H	-45.33	-13.00	-32.33	-65.03	-49.90	4.57
3500.60	V	-30.97	-13.00	-17.97	-42.81	-38.20	7.23
5250.90	V	-35.60	-13.00	-22.60	-52.12	-42.34	6.74
7001.20	V	-40.90	-13.00	-27.90	-65.30	-45.47	4.57

Note: EIRP = S.G Power value + Correction factor.

Mode							
LTE Band 4, QPSK, CB:10 MHz, 1 RB Offset 0, Channel: 20000							
Frequency (MHz)	Antenna Polarity	E.I.R.P (dBm)	Limit (dBm)	Margin (dB)	S.A Reading (dBm)	S.G Power Vaule (dBm)	Correction Factor (dB)
3421.20	H	-44.55	-13.00	-31.55	-55.51	-51.98	7.43
5131.80	H	-42.73	-13.00	-29.73	-59.41	-49.38	6.65
6842.40	H	-45.85	-13.00	-32.85	-64.88	-50.86	5.01
3421.20	V	-38.24	-13.00	-25.24	-49.21	-45.67	7.43
5131.80	V	-37.58	-13.00	-24.58	-54.15	-44.23	6.65
6842.40	V	-45.93	-13.00	-32.93	-65.10	-50.94	5.01

Mode							
LTE Band 4, QPSK, CB:10 MHz, 1 RB Offset 0, Channel: 20175							
Frequency (MHz)	Antenna Polarity	E.I.R.P (dBm)	Limit (dBm)	Margin (dB)	S.A Reading (dBm)	S.G Power Vaule (dBm)	Correction Factor (dB)
3456.20	H	-42.06	-13.00	-29.06	-53.45	-49.40	7.34
5184.30	H	-41.68	-13.00	-28.68	-58.28	-48.38	6.70
6912.40	H	-45.92	-13.00	-32.92	-65.25	-50.74	4.82
3456.20	V	-34.83	-13.00	-21.83	-46.18	-42.17	7.34
5184.30	V	-37.10	-13.00	-24.10	-53.63	-43.80	6.70
6912.40	V	-45.63	-13.00	-32.63	-65.35	-50.45	4.82

Mode							
LTE Band 4, QPSK, CB:10 MHz, 1 RB Offset 0, Channel: 20350							
Frequency (MHz)	Antenna Polarity	E.I.R.P (dBm)	Limit (dBm)	Margin (dB)	S.A Reading (dBm)	S.G Power Vaule (dBm)	Correction Factor (dB)
3491.20	H	-38.57	-13.00	-25.57	-50.38	-45.83	7.26
5236.80	H	-40.30	-13.00	-27.30	-56.86	-47.03	6.73
6982.40	H	-45.39	-13.00	-32.39	-65.02	-50.02	4.63
3491.20	V	-31.29	-13.00	-18.29	-43.02	-38.55	7.26
5236.80	V	-35.77	-13.00	-22.77	-52.29	-42.50	6.73
6982.40	V	-44.94	-13.00	-31.94	-65.20	-49.57	4.63

Note: EIRP = S.G Power value + Correction factor.

Mode							
LTE Band 4, QPSK, CB:15 MHz, 1 RB Offset 0, Channel: 20025							
Frequency (MHz)	Antenna Polarity	E.I.R.P (dBm)	Limit (dBm)	Margin (dB)	S.A Reading (dBm)	S.G Power Vaule (dBm)	Correction Factor (dB)
3421.80	H	-44.19	-13.00	-31.19	-55.16	-51.62	7.43
5132.70	H	-42.23	-13.00	-29.23	-58.91	-48.88	6.65
6843.60	H	-45.98	-13.00	-32.98	-65.02	-50.98	5.00
3421.80	V	-38.11	-13.00	-25.11	-49.09	-45.54	7.43
5132.70	V	-37.84	-13.00	-24.84	-54.40	-44.49	6.65
6843.60	V	-45.84	-13.00	-32.84	-65.03	-50.84	5.00

Mode							
LTE Band 4, QPSK, CB:15 MHz, 1 RB Offset 0, Channel: 20175							
Frequency (MHz)	Antenna Polarity	E.I.R.P (dBm)	Limit (dBm)	Margin (dB)	S.A Reading (dBm)	S.G Power Vaule (dBm)	Correction Factor (dB)
3451.80	H	-42.05	-13.00	-29.05	-53.39	-49.40	7.35
5177.70	H	-41.63	-13.00	-28.63	-58.23	-48.32	6.69
6903.60	H	-45.89	-13.00	-32.89	-65.18	-50.73	4.84
3451.80	V	-35.01	-13.00	-22.01	-46.32	-42.36	7.35
5177.70	V	-37.08	-13.00	-24.08	-53.60	-43.77	6.69
6903.60	V	-45.63	-13.00	-32.63	-65.27	-50.47	4.84

Mode							
LTE Band 4, QPSK, CB:15 MHz, 1 RB Offset 0, Channel: 20325							
Frequency (MHz)	Antenna Polarity	E.I.R.P (dBm)	Limit (dBm)	Margin (dB)	S.A Reading (dBm)	S.G Power Vaule (dBm)	Correction Factor (dB)
3481.80	H	-39.60	-13.00	-26.60	-51.30	-46.88	7.28
5222.70	H	-40.91	-13.00	-27.91	-57.47	-47.63	6.72
6963.60	H	-45.61	-13.00	-32.61	-65.15	-50.29	4.68
3481.80	V	-31.80	-13.00	-18.80	-43.44	-39.08	7.28
5222.70	V	-35.69	-13.00	-22.69	-52.21	-42.41	6.72
6963.60	V	-44.97	-13.00	-31.97	-65.08	-49.65	4.68

Note: EIRP = S.G Power value + Correction factor.

Mode							
LTE Band 4, QPSK, CB:20 MHz, 1 RB Offset 0, Channel: 20050							
Frequency (MHz)	Antenna Polarity	E.I.R.P (dBm)	Limit (dBm)	Margin (dB)	S.A Reading (dBm)	S.G Power Vaule (dBm)	Correction Factor (dB)
3422.40	H	-44.93	-13.00	-31.93	-55.91	-52.36	7.43
5133.60	H	-42.49	-13.00	-29.49	-59.17	-49.14	6.65
6844.80	H	-46.00	-13.00	-33.00	-65.04	-51.00	5.00
3422.40	V	-38.09	-13.00	-25.09	-49.07	-45.52	7.43
5133.60	V	-37.79	-13.00	-24.79	-54.35	-44.44	6.65
6844.80	V	-46.05	-13.00	-33.05	-65.24	-51.05	5.00

Mode							
LTE Band 4, QPSK, CB:20 MHz, 1 RB Offset 0, Channel: 20175							
Frequency (MHz)	Antenna Polarity	E.I.R.P (dBm)	Limit (dBm)	Margin (dB)	S.A Reading (dBm)	S.G Power Vaule (dBm)	Correction Factor (dB)
3447.40	H	-41.91	-13.00	-28.91	-53.19	-49.27	7.36
5171.10	H	-41.64	-13.00	-28.64	-58.26	-48.32	6.68
6894.80	H	-45.93	-13.00	-32.93	-65.18	-50.79	4.86
3447.40	V	-34.97	-13.00	-21.97	-46.22	-42.33	7.36
5171.10	V	-37.10	-13.00	-24.10	-53.63	-43.78	6.68
6894.80	V	-45.56	-13.00	-32.56	-65.13	-50.42	4.86

Mode							
LTE Band 4, QPSK, CB:20 MHz, 1 RB Offset 0, Channel: 20300							
Frequency (MHz)	Antenna Polarity	E.I.R.P (dBm)	Limit (dBm)	Margin (dB)	S.A Reading (dBm)	S.G Power Vaule (dBm)	Correction Factor (dB)
3472.40	H	-38.66	-13.00	-25.66	-50.25	-45.96	7.30
5208.60	H	-40.30	-13.00	-27.30	-56.87	-47.01	6.71
6944.80	H	-45.50	-13.00	-32.50	-64.96	-50.23	4.73
3472.40	V	-31.57	-13.00	-18.57	-43.10	-38.87	7.30
5208.60	V	-35.94	-13.00	-22.94	-52.46	-42.65	6.71
6944.80	V	-44.99	-13.00	-31.99	-64.95	-49.72	4.73

Note: EIRP = S.G Power value + Correction factor.

4 Test laboratory information

Established in 2012, ICC provides foremost EMC & RF Testing and advisory consultation services by our skilled engineers and technicians. Our services employ a wide variety of advanced edge test equipment and one of the widest certification extents in the business.

International Certification Corp (EMC and Wireless Communication Laboratory), it is our definitive objective is to institute long term, trust-based associations with our clients. The expectation we set up with our clients is based on outstanding service, practical expertise and devotion to a certified value structure. Our passion is to grant our clients with best EMC / RF services by oriented knowledgeable and accommodating staff.

Our Test sites are located at Linkou District and Kwei Shan Hsiang. Location map can be found on our website <http://www.icertifi.com.tw>.

Linkou

Tel: 886-2-2601-1640

No. 30-2, Ding Fwu Tsuen, Lin
Kou District, New Taipei City,
Taiwan, R.O.C.

Kwei Shan

Tel: 886-3-271-8666

No. 3-1, Lane 6, Wen San 3rd St.,
Kwei Shan District, Tao Yuan City
333, Taiwan, R.O.C.

Kwei Shan Site II

Tel: 886-3-271-8640

No. 14-1, Lane 19, Wen San 3rd
St., Kwei Shan District, Tao Yuan
City 333, Taiwan, R.O.C..

If you have any suggestion, please feel free to contact us as below information

Tel: 886-3-271-8666

Fax: 886-3-318-0155

Email: ICC_Service@icertifi.com.tw

==END==