

Technical Description

The brief circuit description is listed as below:

- 1) U2 acts as 2.4GHz RF Transceiver (EM9201).
- 2) U1 acts as MCU (SNC82511A).
- 3) U3 acts as Voltage Regulator (6206).
- 4) Y1 (16.384MHz) and Y2 (32.768kHz) act as Crystal Oscillator for U1.
- 5) X1 (26MHz) acts as Crystal Oscillator for U2.
- 6) S1 and S2 act as Control Buttons.
- 7) D1, D2, D3, D4, D5 and D6 act as LEDs.
- 8) LS1 acts as Speaker.

Antenna Type: Internal antenna

Antenna Gain: 0dBi

Nominal rated field strength: 86.6 dB μ V/m at 3m

Maximum allowed field strength of production tolerance: +/- 3dB

CMM-9201/9203-V7.4

Mini 2.4GHz Transceiver Module



Description

The CMM-9201 module is a miniaturised 2.4GHz transceiver module based on EM Microelectronic's low energy RF transceiver EM9201/03. The module is highly optimized for proprietary link application requiring ultra low power consumption and short time-to-market. It offers a plug and play solution for any EM9201 application without any additional hardware nor RF layout. Built in with a folded-dipole PCB antenna, this small sized, low cost module provides an ideal solution to wireless 2.4GHz license-free application worldwide.

The EM9201/03 is a low-voltage 2.4GHz transceiver IC with built-in link-layer logic permitting proprietary wireless links in the 2.400 ... 2.4835 GHz ISM band. It has a radio core with a low-IF architecture and GFSK modulation scheme being compliant with the emerging Bluetooth low energy technology standard..

1.1 Features

- Fully integrated 2.4 GHz transceiver (Chip on Board)
- Operating voltage 1.9V ~ 3.6V
- Mini-sized (18.5mm x 13mm)
- Integrated Battery Low Detection
- Programmable RF output level (-18 to +3 dBm) via software control
- Low current consumption
(0.8uA at standby, 14.0mA (@2.5V) in RX, 14.0 mA (@2.5V) in TX (0dBm))
- 1Mb/s (CMM-9201), 2Mb/s (CMM-9203) data rate
- No Tuning necessary
- Reaches 60m at open space line of sight
- GFSK modulation
- SPI interface to host controller
- Very easy to assembly, all components in one side

1.2 Module Dimension & Pin Assignment

Pin Number	Pin Name	Pin Description
1	GND	Ground Connection
2	CS	Chip Select (Active LO)
3	IRQ	Interrupt Output for external host Controller
4	SDO	SPI Data Output
5	SDI	SPI Data Input
6	SCK	SPI Clock Input
7	VCC	Power Supply

CMM-9201/9203-V7.4 Mini 2.4GHz Transceiver Module

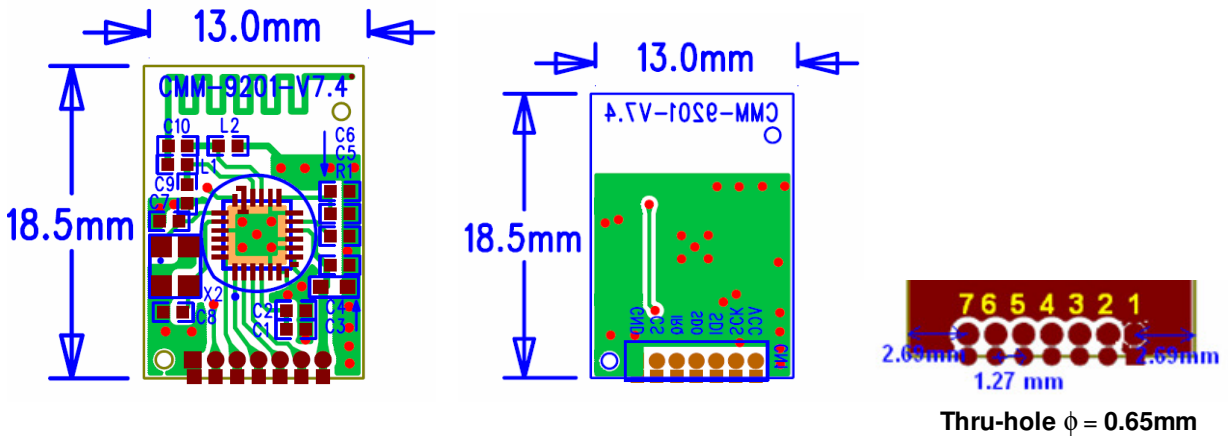

FRONT



BACK

Module thickness: 2.2mm max (SMT crystal)

1.3 Module Reference Circuit diagram

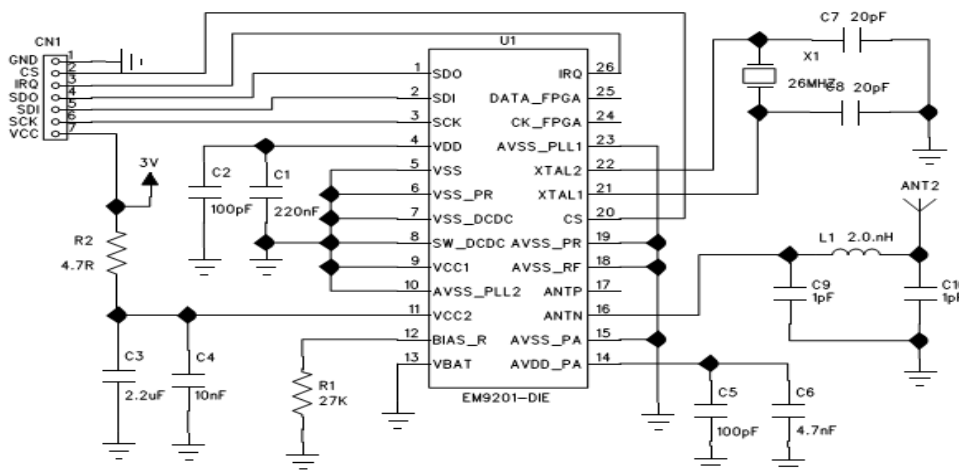

CMM-9201/9203-V7.4

Mini 2.4GHz Transceiver Module

C-MAX

1.4 Module Electrical Specifications

Specification	CMM-9201	CMM-9203
Voltage Range	1.9V to 3.6V	1.9V to 3.6V
Battery-low detection (adjustable)	2.1V to 2.45V	2.1V to 2.45V
Frequency Range	2.4 to 2.484 GHz	2.4 to 2.484 GHz
Modulation	GFSK	GFSK
On-air data rate	1Mbps	2Mbps
RF channels	40	40
Current Consumption (Vcc = 2.5V)		
- RX mode	14.0mA	14.0mA
- TX mode (0dBm output power)	14.0mA	14.0mA
- Standby Low Power mode	93 uA (typ.)	93 uA (typ.)
- Power-down mode	0.85uA	0.85uA
Programmable output power	-18dBm to +3dBm	-18dBm to +3dBm
RF setup time (Standby <-> TX/RX)	150 us (typ.)	150 us (typ.)

2. Ordering information

C-MAX Module Part Number	Max Data Rate	Typical Operating Voltage
CMM-9201-V7.4	1 Mbps	1.9 ~ 3.6V
CMM-9203-V7.4	2 Mbps	1.9 ~ 3.6V

Disclaimer of Warranty

Information furnished is believed to be accurate and reliable. However C-MAX assumes no responsibility, neither for the consequences of use of such information nor for any infringement of patents or other rights of third parties, which may result from its use. Specifications mentioned in this publication are subject to change without notice. This publication supersedes and replaces all information previously supplied. C-MAX products are not authorized for use as critical components in life support devices without express written approval of C-MAX.

Note

It is not given warranty that the declared circuits, devices, facilities, components, assembly groups or treatments included herein are free from legal claims of third parties. The declared data are serving only to description of product. They are not guaranteed properties as defined by law. The examples are given without obligation and cannot give rise to any liability.

Reprinting this data sheet - or parts of it - is only allowed with a license of the publisher.

C-MAX reserves the right to make changes on this specification without notice at any time.

C-MAX Asia Ltd

Unit 117, 1/F.,
Liven House,
61-63 King Yip Street,
Kwun Tong, Kowloon, HK SAR
Tel.: +852-2798-5182
Fax: +852-2798-5379
e-mail: enquiry@c-max.com.hk

C-MAX Technology Ltd (Shenzhen)

Room 922-923, 9/F,
Kerry Centre,
2008 Reminnan Road,
Luohu District, Shenzhen, PR China,
Tel: +86-755-25181858
Fax: +86-755-25181859

SPEC No.	Revision	State	C-MAX printed	Version	Page
CMM9201/03-V7.4 2.4GHz Transceiver module	1.2	2014-01-09	2014-01-09	English	3 of 3