

# MAIN PCB

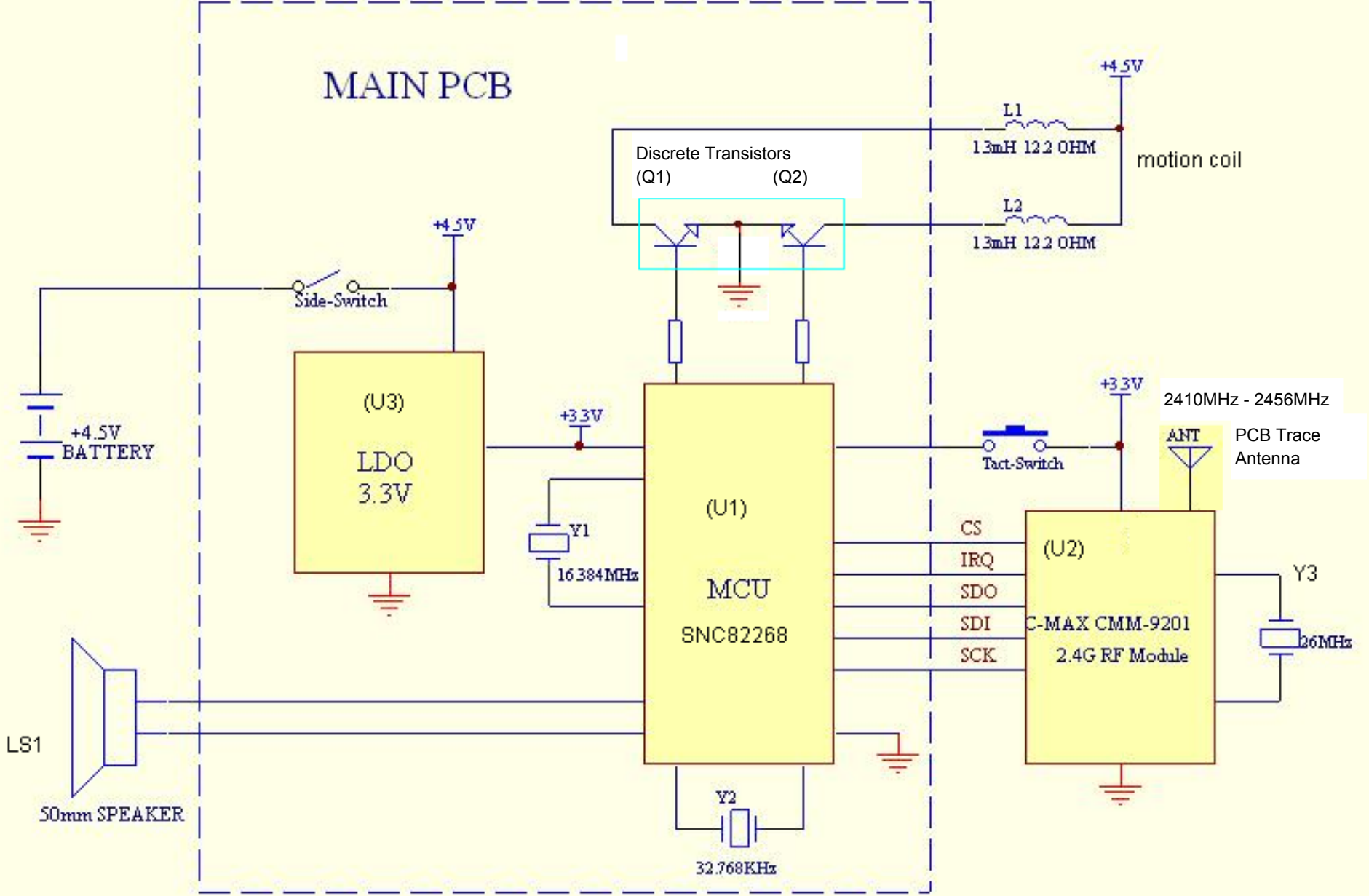



### 1.1 Block diagram

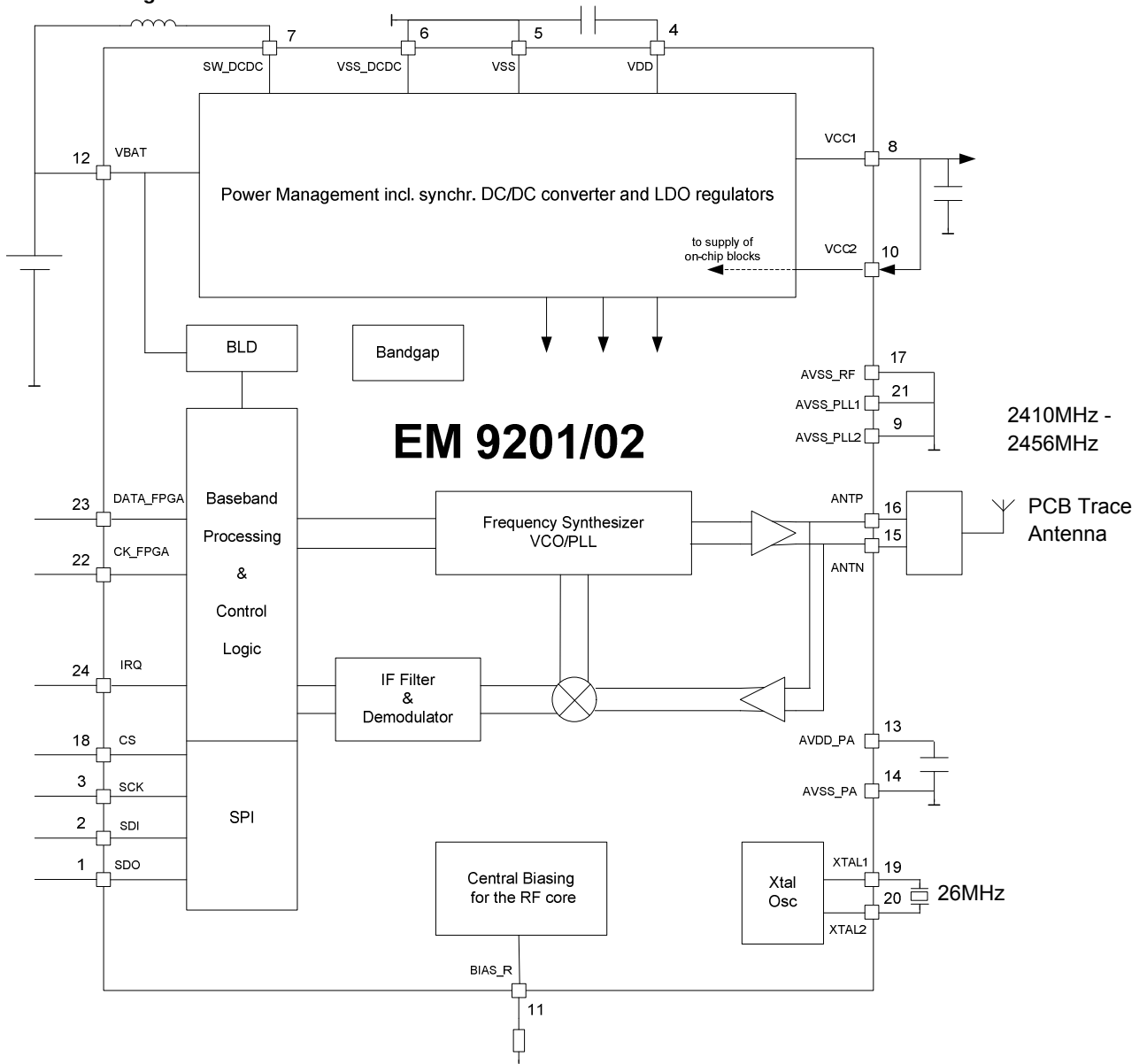

Figure 1 Simplified block diagram (DC/DC configuration).

### 1.2 Pin information (all versions)

Pin Nr	Name	I/O	Description
1	SDO	O	SPI data output
2	SDI	I	SPI data input
3	SCK	I	SPI clock input
4	VDD	O	Positive supply of digital part (baseband and frequency synthesizer)
5	VSS		Negative supply of digital part (plus ESD protection digital segment) <sup>1)</sup>
6	VSS_DCDC		Negative supply for DC/DC converter <sup>1)</sup>
7	SW_DCDC	I/O	Coil switch of DC/DC converter
8	VCC1	O	Output of DC/DC converter. On Version 2 ( no DC/DC) connected to ground <sup>2)</sup>
9	AVSS_PLL2		Negative supply of PLL <sup>1)</sup>