

TEST REPORT

Report No.: 21080412HKG-002

Hallmark Marketing Company, LLC

Application For Certification
(Original Grant)

FCC ID: SQ9RTX7310

Transceiver

Prepared and Checked by:

Approved by:

Signed On File
Wong Cheuk Ho, Herbert
Lead Engineer

Wong Kwok Yeung, Kenneth
Assistant Supervisor
Date: December 01, 2021

Intertek's standard Terms and Conditions can be obtained at our website <http://www.intertek.com/terms/>.

The test report only allows to be revised within the retention period unless further standard or the requirement was noticed.

This report is for the exclusive use of Intertek's Client and is provided pursuant to the agreement between Intertek and its Client. Intertek's responsibility and liability are limited to the terms and conditions of the agreement. Intertek assumes no liability to any party, other than to the Client in accordance with the agreement, for any loss, expense or damage occasioned by the use of this report. Only the Client is authorized to permit copying or distribution of this report and then only in its entirety. Any use of the Intertek name or one of its marks for the sale or advertisement of the tested material, product or service must first be approved in writing by Intertek. The observations and test results in this report are relevant only to the sample tested. This report by itself does not imply that the material, product, or service is or has ever been under an Intertek certification program.

© 2017 Intertek

TEST REPORT

GENERAL INFORMATION

Grantee:	Hallmark Marketing Company, LLC
Grantee Address:	2501 McGee Street, MD 339, PO Box 419580, Kansas City, MO 64141, United States
Contact Person:	Albert Mauro
Tel:	816-274-4320
Fax:	N/A
e-mail:	AL.Mauro@hallmark.com
Manufacturer:	Hallmark Marketing,LCC
Manufacturer Address:	2501 McGee PO Box 419580 Kansas City MO 64141
Brand Name:	N/A
Model:	RTX7310
Type of EUT:	Transceiver
Description of EUT:	2.4GHz Module
Serial Number:	N/A
FCC ID:	SQ9RTX7310
Date of Sample Submitted:	August 09, 2021
Date of Test:	August 09, 2021 to November 30, 2021
Report No.:	21080412HKG-002
Report Date:	December 01, 2021
Environmental Conditions:	Temperature: +10 to 40°C Humidity: 10 to 90%
Conclusion:	Test was conducted by client submitted sample. The submitted sample as received complied with the 47 CFR Part 15 Certification.

TEST REPORT

SUMMARY OF TEST RESULT

Test Specification	Reference	Results
Transmitter Power Line Conducted Emissions	15.207	Pass
Radiated Emission Radiated Emission on the Bandedge	15.249, 15.209	Pass
Radiated Emission in Restricted Bands	15.205	Pass

The equipment under test is found to be complying with the following standards:
FCC Part 15, October 1, 2020 Edition

- Note:
1. The EUT uses a permanently attached antenna which, in accordance to section 15.203, is considered sufficient to comply with the provisions of this section.
 2. Pursuant to FCC part 15 Section 15.215(c), the 20 dB bandwidth of the emission was contained within the frequency band designated (mentioned as above) which the EUT operated. The effects, if any, from frequency sweeping, frequency hopping, other modulation techniques and frequency stability over excepted variations in temperature and supply voltage were considered.

TEST REPORT

TABLE OF CONTENTS

1.0 GENERAL DESCRIPTION 5

 1.1 Product Description 5

 1.2 Related Submittal(s) Grants 5

 1.3 Test Methodology 5

 1.4 Test Facility 5

2.0 SYSTEM TEST CONFIGURATION 6

 2.1 Justification 6

 2.2 EUT Exercising Software 6

 2.3 Special Accessories 6

 2.4 Measurement Uncertainty 6

 2.5 Support Equipment List and Description 6

3.0 EMISSION RESULTS 7

 3.1 Field Strength Calculation 7

 3.2 Radiated Emission Configuration Photograph 8

 3.3 Radiated Emission Data 8

 3.4 Conducted Emission Configuration Photograph 8

 3.5 Conducted Emission Data 8

4.0 EQUIPMENT PHOTOGRAPHS 14

5.0 PRODUCT LABELLING 14

6.0 TECHNICAL SPECIFICATIONS 14

7.0 INSTRUCTION MANUAL 14

8.0 MISCELLANEOUS INFORMATION 15

 8.1 Radiated Emission on the Bandedge 15

 8.2 Discussion of Pulse Desensitization 18

 8.3 Calculation of Average Factor 18

 8.4 Emissions Test Procedures 19

9.0 CONFIDENTIALITY REQUEST 23

10.0 EQUIPMENT LIST 23

TEST REPORT

1.0 GENERAL DESCRIPTION

1.1 Product Description

The Equipment Under Test (Model: RTX7310) is a 2.4GHz Module which is operating at frequency range of 2407MHz to 2477MHz with 71 channels (1MHz channel spacing). It is intended to be used as short-range radio communication for embedded application inside a host. The EUT is powered by the host (3.3VDC).

Antenna Type: Internal, Integral

For electronic filing, the brief circuit description is saved with filename: descri.pdf.

1.2 Related Submittal(s) Grants

This is a single modular application for certification of a transceiver.

1.3 Test Methodology

Both AC mains line-conducted and radiated emission measurements were performed according to the procedures in ANSI C63.10 (2013). All radiated measurements were performed in an 3m Chamber. Preliminary scans were performed in the 3m Chamber only to determine worst case modes. All radiated tests were performed at an antenna to EUT distance of 3 meters, unless stated otherwise in the “**Justification Section**” of this Application.

1.4 Test Facility

The 3m Chamber and conducted measurement facility used to collect the radiated data is located at Workshop No. 3, G/F., World-Wide Industrial Centre, 43-47 Shan Mei Street, Fo Tan, Sha Tin, N.T., Hong Kong SAR, China. This test facility and site measurement data have been placed on file with the FCC.

TEST REPORT

2.0 SYSTEM TEST CONFIGURATION

2.1 Justification

The system was configured for testing in a typical fashion (as a customer would normally use it), and in the confines as outlined in ANSI C63.10 (2013).

The device was powered by 3.3VDC.

For maximizing emissions, the EUT was rotated through 360°, the antenna height was varied from 1 meter to 4 meters above the ground plane, and the antenna polarization was changed. This step by step procedure for maximizing emissions led to the data reported in Exhibit 3.0.

The rear of unit shall be flushed with the rear of the table.

The equipment under test (EUT) was configured for testing in a typical fashion (as a customer would normally use it). The EUT was mounted to a plastic stand if necessary and placed on the wooden turntable, which enabled the engineer to maximize emissions through its placement in the three orthogonal axes.

2.2 EUT Exercising Software

The EUT exercise program (if any) used during radiated testing was designed to exercise the various system components in a manner similar to a typical use.

2.3 Special Accessories

There are no special accessories necessary for compliance of this product.

2.4 Measurement Uncertainty

Decision Rule for compliance: For FCC/IC standard, the measured value must be within the limits of applicable standard without accounting for the measurement uncertainty. For EN/IEC/HKTA/HKTC standard, conformity rules will be used as per standard directly excepted EN/IEC 61000-3-2, EN/IEC 61000-3-3, HKTA1004, HKCA1008, HKTA1019, HKTA1020, HKTA1041 and HKTA1044. For these excepted or not mentioned standards, Cl 4.2.2 of ILAC-G8:09/2019 decision rules will be reference and guard band will be equal to our measurement uncertainty with 95% confidence level (k=2). In case, the measured value is within guard band region, undetermined decision will be used.

2.5 Support Equipment List and Description

1. test-jig (Provided by applicant)

TEST REPORT

3.0 EMISSION RESULTS

Data is included of the worst case configuration (the configuration which resulted in the highest emission levels). A sample calculation, configuration photographs and data tables of the emissions are included.

3.1 Field Strength Calculation

The field strength is calculated by adding the Antenna Factor and Cable Factor, and subtracting the Amplifier Gain (if any), Average Factor (optional) from the measured reading. The basic equation with a sample calculation is as follows:

$$FS = RA + AF + CF - AG - AV$$

where FS = Field Strength in dB μ V/m

RA = Receiver Amplitude (including preamplifier) in dB μ V

CF = Cable Attenuation Factor in dB

AF = Antenna Factor in dB

AG = Amplifier Gain in dB

AV = Average Factor in dB

In the following table(s), the reading shown on the data table reflects the preamplifier gain. An example for the calculations in the following table is as follows:

$$FS = RR + LF$$

where FS = Field Strength in dB μ V/m

RR = RA - AG - AV in dB μ V

LF = CF + AF in dB

Assume a receiver reading of 52.0 dB μ V is obtained. The antenna factor of 7.4 dB and cable factor of 1.6 dB are added. The amplifier gain of 29 dB and average factor of 5 dB are subtracted, giving a field strength of 27 dB μ V/m. This value in dB μ V/m was converted to its corresponding level in μ V/m.

$$RA = 52.0 \text{ dB}\mu\text{V/m}$$

$$AF = 7.4 \text{ dB}$$

$$CF = 1.6 \text{ dB}$$

$$AG = 29.0 \text{ dB}$$

$$AV = 5.0 \text{ dB}$$

$$FS = RR + LF$$

$$FS = 18 + 9 = 27 \text{ dB}\mu\text{V/m}$$

$$RR = 18.0 \text{ dB}\mu\text{V}$$

$$LF = 9.0 \text{ dB}$$

$$\text{Level in } \mu\text{V/m} = \text{Common Antilogarithm } [(27 \text{ dB}\mu\text{V/m})/20] = 22.4 \mu\text{V/m}$$

TEST REPORT

3.2 Radiated Emission Configuration Photograph

The worst case in radiated emission was found at 2483.500 MHz

For electronic filing, the worst case radiated emission configuration photographs are saved with filename: radiated photos.pdf.

3.3 Radiated Emission Data

The data on the following page lists the significant emission frequencies, the limit and the margin of compliance. Numbers with a minus sign are below the limit.

Judgment: Passed by 6.2 dB

3.4 Conducted Emission Configuration Photograph

The worst case in line-conducted emission was found at 7.521 MHz

For electronic filing, the worst-case line-conducted configuration photographs are saved with filename: conducted photo.pdf.

3.5 Conducted Emission Data

For electronic filing, the graph and data table of conducted emission is saved with filename: conducted.pdf.

Judgment: Pass by 44.0 dB

TEST REPORT

CONDUCTED EMISSION

Model: RTX7310

Date of Test: November 30, 2021

Worst-Case Operating Mode: Normal Operating

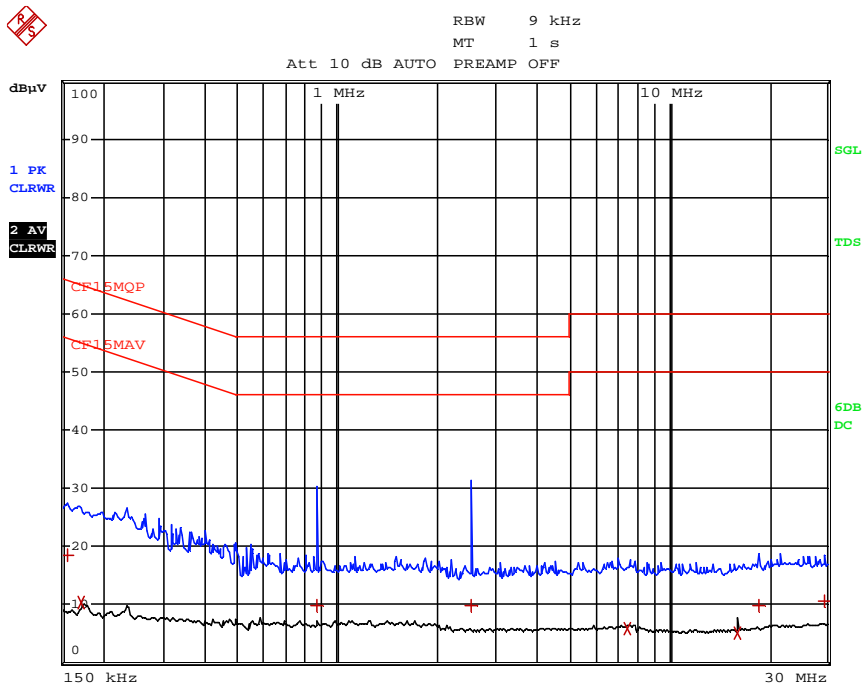

EDIT PEAK LIST (Final Measurement Results)				
TRACE	FREQUENCY	LEVEL dBµV	DELTA	LIMIT dB
Trace1:	CF15MQP			
Trace2:	CF15MAV			
Trace3:	---			
1	Quasi Peak 154.5 kHz	18.55 L1	-47.20	
2	CISPR Average 172.5 kHz	10.29 L1	-44.54	
1	Quasi Peak 870 kHz	9.89 L1	-46.10	
1	Quasi Peak 2.535 MHz	9.87 N	-46.12	
2	CISPR Average 7.521 MHz	5.99 N	-44.00	
2	CISPR Average 15.9855 MHz	5.10 N	-44.89	
1	Quasi Peak 18.6495 MHz	9.93 L1	-50.06	
1	Quasi Peak 29.2875 MHz	10.68 L1	-49.31	

Note: Measurement Uncertainty is ±4.2dB at a level of confidence of 95%.

TEST REPORT

RADIATED EMISSIONS

Model: RTX7310

Date of Test: November 30, 2021

Worst-Case Operating Mode: Transmitting

Table 1
Pursuant to FCC Part 15 Section 15.249 Requirement

Lowest Channel

Polarization	Frequency (MHz)	Reading (dBµV)	Pre-Amp Gain (dB)	Antenna Factor (dB)	Net at 3m - (Average) (dBµV/m)	Average Limit at 3m (dBµV/m)	Margin (dB)
H	2390.000	40.8	33	29.4	37.2	54.0	-16.8
H	2407.000	66.1	33	29.4	62.5	94.0	-31.5
V	4814.000	29.9	33	34.9	31.8	54.0	-22.2
H	7221.000	28.6	33	37.9	33.5	54.0	-20.5
H	9628.000	23.4	33	40.4	30.8	54.0	-23.2
H	12035.000	23.0	33	40.5	30.5	54.0	-23.5
H	14442.000	23.2	33	40.0	30.2	54.0	-23.8

Polarization	Frequency (MHz)	Reading (dBµV)	Pre-Amp Gain (dB)	Antenna Factor (dB)	Net at 3m - Peak (dBµV/m)	Peak Limit at 3m (dBµV/m)	Margin (dB)
H	2390.000	68.4	33	29.4	64.8	74.0	-9.2
H	2407.000	100.4	33	29.4	96.8	114.0	-17.2
V	4814.000	48.7	33	34.9	50.6	74.0	-23.4
H	7221.000	44.6	33	37.9	49.5	74.0	-24.5
H	9628.000	31.0	33	40.4	38.4	74.0	-35.6
H	12035.000	31.3	33	40.5	38.8	74.0	-35.2
H	14442.000	31.2	33	40.0	38.2	74.0	-35.8

- NOTES:
1. Peak Detector Data unless otherwise stated.
 2. Average detector is applied according to ANSI C63.10.
 3. All measurements were made at 3 meters.
 4. Negative sign in the column shows value below limit.
 5. Horn antenna is used for the emission over 1000MHz.
 6. Emission within the restricted band meets the requirement of FCC Part 15 Section 15.205.
 7. Measurement Uncertainty is ±5.3dB at a level of confidence of 95%.

TEST REPORT

Model: RTX7310
Date of Test: November 30, 2021
Worst-Case Operating Mode: Transmitting

Table 2
Pursuant to FCC Part 15 Section 15.249 Requirement

Middle Channel

Polarization	Frequency (MHz)	Reading (dBµV)	Pre-Amp Gain (dB)	Antenna Factor (dB)	Net at 3m - (Average) (dBµV/m)	Average Limit at 3m (dBµV/m)	Margin (dB)
H	2443.000	68.1	33	29.4	64.5	94.0	-29.5
V	4886.000	31.7	33	34.9	33.6	54.0	-20.4
H	7329.000	29.5	33	37.9	34.4	54.0	-19.6
H	9772.000	23.1	33	40.4	30.5	54.0	-23.5
H	12215.000	23.3	33	40.5	30.8	54.0	-23.2
H	14658.000	25.1	33	38.4	30.5	54.0	-23.5

Polarization	Frequency (MHz)	Reading (dBµV)	Pre-Amp Gain (dB)	Antenna Factor (dB)	Net at 3m - Peak (dBµV/m)	Peak Limit at 3m (dBµV/m)	Margin (dB)
H	2443.000	102.0	33	29.4	98.4	114.0	-15.6
V	4886.000	51.6	33	34.9	53.5	74.0	-20.5
H	7329.000	46.9	33	37.9	51.8	74.0	-22.2
H	9772.000	30.8	33	40.4	38.2	74.0	-35.8
H	12215.000	30.9	33	40.5	38.4	74.0	-35.6
H	14658.000	32.8	33	38.4	38.2	74.0	-35.8

- NOTES:
1. Peak Detector Data unless otherwise stated.
 2. Average detector is applied according to ANSI C63.10.
 3. All measurements were made at 3 meters.
 4. Negative sign in the column shows value below limit.
 5. Horn antenna is used for the emission over 1000MHz.
 6. Emission within the restricted band meets the requirement of FCC Part 15 Section 15.205.
 7. Measurement Uncertainty is ±5.3dB at a level of confidence of 95%.

TEST REPORT

Model: RTX7310

Date of Test: November 30, 2021

Worst-Case Operating Mode: Transmitting

**Table 3
Pursuant to FCC Part 15 Section 15.249 Requirement**

Highest Channel

Polarization	Frequency (MHz)	Reading (dBµV)	Pre-Amp Gain (dB)	Antenna Factor (dB)	Net at 3m - (Average) (dBµV/m)	Average Limit at 3m (dBµV/m)	Margin (dB)
H	2477.000	68.4	33	29.4	64.8	94.0	-29.2
H	2483.500	41.2	33	29.4	37.6	54.0	-16.4
V	4954.000	30.5	33	34.9	32.4	54.0	-21.6
H	7431.000	29.9	33	37.9	34.8	54.0	-19.2
H	9908.000	22.8	33	40.4	30.2	54.0	-23.8
H	12385.000	22.3	33	40.5	29.8	54.0	-24.2
H	14862.000	24.6	33	38.4	30.0	54.0	-24.0

Polarization	Frequency (MHz)	Reading (dBµV)	Pre-Amp Gain (dB)	Antenna Factor (dB)	Net at 3m - Peak (dBµV/m)	Peak Limit at 3m (dBµV/m)	Margin (dB)
H	2477.000	102.4	33	29.4	98.8	114.0	-15.2
H	2483.500	71.4	33	29.4	67.8	74.0	-6.2
V	4954.000	49.6	33	34.9	51.5	74.0	-22.5
H	7431.000	49.7	33	37.9	54.6	74.0	-19.4
H	9908.000	30.8	33	40.4	38.2	74.0	-35.8
H	12385.000	31.0	33	40.5	38.5	74.0	-35.5
H	14862.000	33.0	33	38.4	38.4	74.0	-35.6

- NOTES:
1. Peak Detector Data unless otherwise stated.
 2. Average detector is applied according to ANSI C63.10.
 3. All measurements were made at 3 meters.
 4. Negative sign in the column shows value below limit.
 5. Horn antenna is used for the emission over 1000MHz.
 6. Emission within the restricted band meets the requirement of FCC Part 15 Section 15.205.
 7. Measurement Uncertainty is ±5.3dB at a level of confidence of 95%.

TEST REPORT

Model: RTX7310

Date of Test: November 30, 2021

Worst-Case Operating Mode: Normal Operating

Table 4
Pursuant to FCC Part 15 Section 15.209 Requirement

Polarization	Frequency (MHz)	Reading (dBμV)	Pre-amp (dB)	Antenna Factor (dB)	Net at 3m (dBμV/m)	Limit at 3m (dBμV/m)	Margin (dB)
H	72.008	23.8	16	7.0	14.8	40.0	-25.2
V	112.750	21.8	16	14.0	19.8	43.5	-23.7
V	118.722	23.5	16	14.0	21.5	43.5	-22.0
V	131.518	22.8	16	14.0	20.8	43.5	-22.7
V	137.368	16.4	16	14.0	14.4	43.5	-29.1
V	150.412	22.6	16	14.0	20.6	43.5	-22.9
V	218.415	15.5	16	17.0	16.5	46.0	-29.5

- NOTES:
1. Quasi-Peak Detector Data unless otherwise stated.
 2. All measurements were made at 3 meters.
 3. Negative sign in the column shows value below limit.
 4. Horn antenna is used for the emission over 1000MHz.
 5. Emission within the restricted band meets the requirement of FCC Part 15 Section 15.205.
 6. Measurement Uncertainty is ±5.3dB at a level of confidence of 95%.

TEST REPORT

4.0 EQUIPMENT PHOTOGRAPHS

For electronic filing, the photographs are saved with filename: external photos.pdf and internal photos.pdf.

5.0 PRODUCT LABELLING

For electronics filing, the FCC ID label artwork and the label location are saved with filename: label.pdf.

6.0 TECHNICAL SPECIFICATIONS

For electronic filing, the block diagram and schematic of the tested EUT are saved with filename: block.pdf and circuit.pdf respectively.

7.0 INSTRUCTION MANUAL

For electronic filing, a preliminary copy of the Instruction Manual is saved with filename: manual.pdf.

This manual will be provided to the end-user with each unit sold/leased in the United States.

TEST REPORT

8.0 MISCELLANEOUS INFORMATION

The miscellaneous information includes details of the test procedure and measured bandwidth / calculation of factor such as pulse desensitization and averaging factor (calculation and timing diagram).

8.1 Radiated Emission on the Bandedge

From the following plots, they show that the fundamental emissions are confined in the specified band (2400MHz to 2483.5MHz). In case of the fundamental emissions are within two standard bandwidths from the bandedge, the delta measurement technique is used for determining bandedge compliance. Standard bandwidth is the bandwidth specified by ANSI C63.10 (2013) for frequency being measured.

Emissions radiated outside of the specified frequency bands, except harmonics, are attenuated by 50dB below the level of the fundamental or to the general radiated emissions limits in Section 15.209, whichever is the lesser attenuation, which meet the requirement of part 15.249(d).

TEST REPORT

PEAK MEASUREMENT

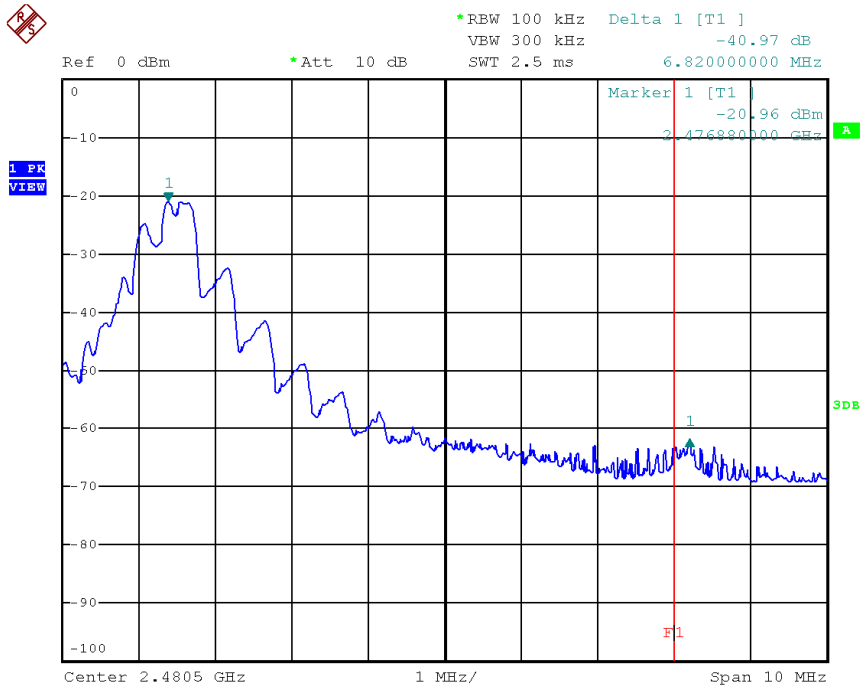
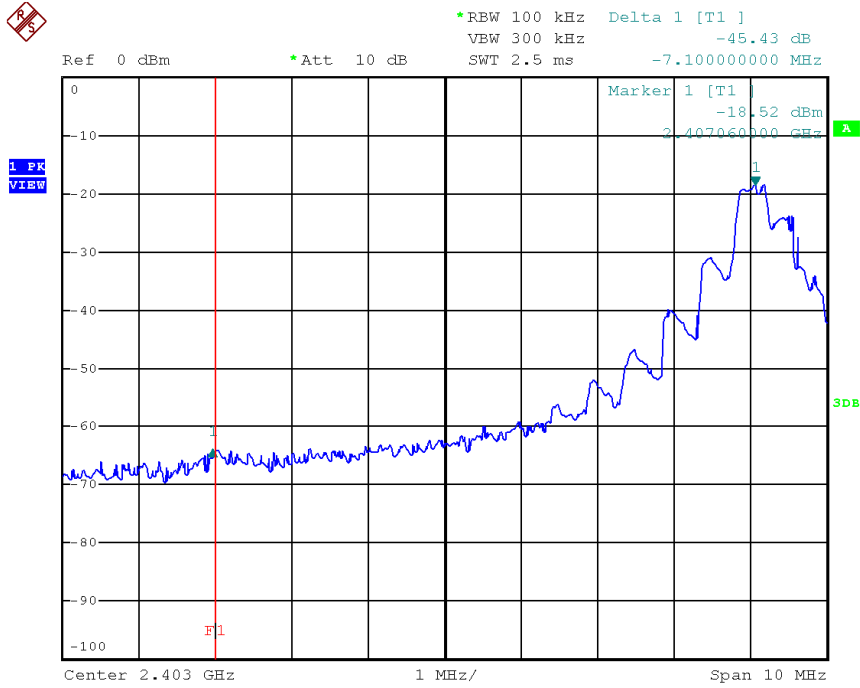

TEST REPORT

PEAK MEASUREMENT

Bandedge compliance is determined by applying marker-delta method, i.e. (Bandedge Plot).

Lower bandedge

Peak Resultant field strength = Fundamental emissions (peak value) – delta from the plot

=96.8 dB μ V/m – 45.4 dB

=51.4 dB μ V/m

Average Resultant field strength = Fundamental emissions (average value) – delta from the plot

=62.5 dB μ V/m – 45.4 dB

=17.1 dB μ V/m

Upper bandedge

Peak Resultant field strength = Fundamental emissions (peak value) – delta from the plot

=98.8 dB μ V/m – 41.0 dB

=57.8 dB μ V/m

Average Resultant field strength = Fundamental emissions (average value) – delta from the plot

=64.8 dB μ V/m – 41.0 dB

=23.8 dB μ V/m

The resultant field strength meets the general radiated emission limit in Section 15.209, which does not exceed 74 dB μ V/m (Peak Limit) and 54 dB μ V/m (Average Limit).

TEST REPORT

8.2 Discussion of Pulse Desensitization

Pulse desensitivity is not applicable for this device. The effective period (T_{eff}) is approximately $625\mu s$ for a digital "1" bit which illustrated on technical specification, with a resolution bandwidth (3dB) of 3MHz, so the pulse desensitivity factor is 0dB.

8.3 Calculation of Average Factor

N/A

TEST REPORT

8.4 Emissions Test Procedures

The following is a description of the test procedure used by Intertek Testing Services Hong Kong Ltd. in the measurements of transmitter operating under the Part 15, Subpart C rules.

The transmitting equipment under test (EUT) is placed on a wooden turntable which is four feet in diameter and approximately 0.8m in height above the ground plane for emission measurement at or below 1GHz and 1.5m in height above the ground plane for emission measurement above 1GHz. During the radiated emissions test, the turntable is rotated and any cables leaving the EUT are manipulated to find the configuration resulting in maximum emissions. The EUT is adjusted through all three orthogonal axis to obtain maximum emission levels. The antenna height and polarization are also varied during the testing to search for maximum signal levels. The height of the antenna is varied from one to four meters.

Detector function for radiated emissions is in peak mode. Average readings, when required, are taken by measuring the duty cycle of the equipment under test and subtracting the corresponding amount in dB from the measured peak readings. A detailed description for the calculation of the average factor can be found in Exhibit 8.3.

The frequency range scanned is from the lowest radio frequency signal generated in the device which is greater than 9 kHz to the tenth harmonic of the highest fundamental frequency or 40 GHz, whichever is lower. For line conducted emissions, the range scanned is 150 kHz to 30 MHz.

TEST REPORT

8.4 Emissions Test Procedures (cont'd)

The EUT is warmed up for 15 minutes prior to the test.

AC power to the unit is varied from 85% to 115% nominal and variation in the fundamental emission field strength is recorded. If battery powered, a new, fully charged battery is used.

Conducted measurements were made as described in ANSI C63.10 (2013).

The IF bandwidth used for measurement of radiated signal strength was 100 kHz or greater when frequency is below 1000 MHz. Where pulsed transmissions of short enough pulse duration warrant, a greater bandwidth is selected according to the recommendations of Hewlett Packard Application Note 150-2. A discussion of whether pulse desensitivity is applicable to this unit is included in this report (See Exhibit 8.1). Above 1000 MHz, a resolution bandwidth of 3 MHz is used.

Transmitter measurements are normally conducted at a measurement distance of three meters. However, to assure low enough noise floor in the forbidden bands and above 1 GHz, signals are acquired at a distance of one meter or less. All measurements are extrapolated to three meters using inverse scaling, unless otherwise reported. Measurements taken at a closer distance are so marked.

TEST REPORT

8.4.1 Radiated Emission Test Setup

The figure below shows the test setup, which is utilized to make these measurements.

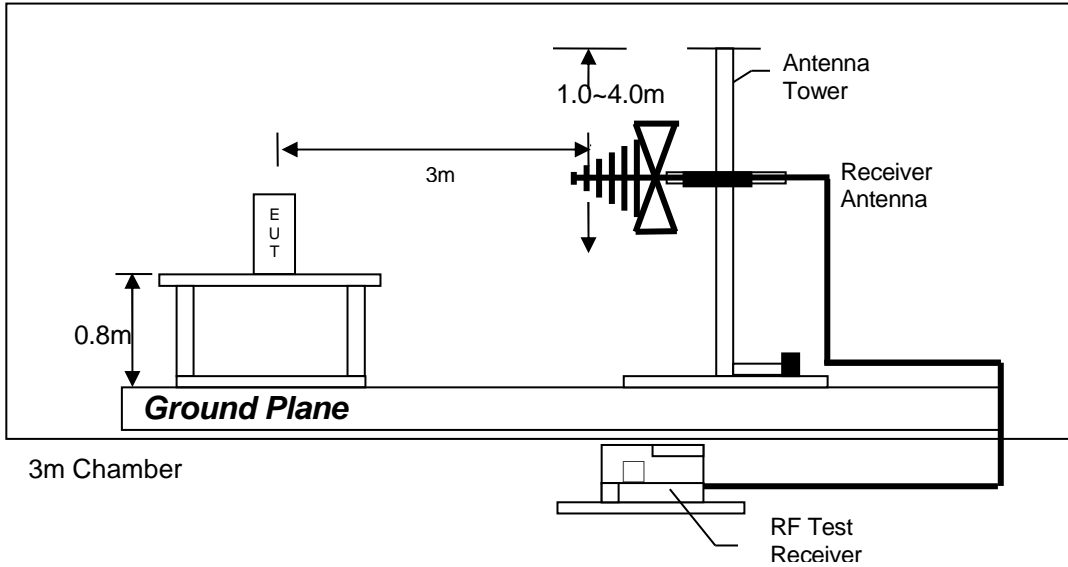

Test setup of radiated emissions up to 1GHz

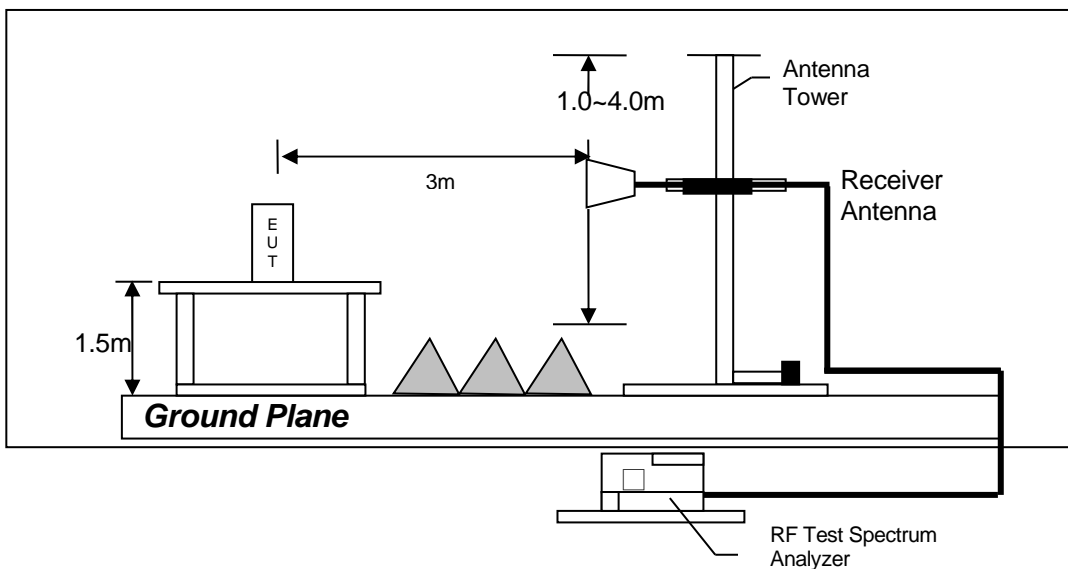

Test setup of radiated emissions above 1GHz

TEST REPORT

8.4.2 Conducted Emission Test Procedures

For tabletop equipment, the EUT along with its peripherals were placed on a 1.0m(W)×1.5m(L) and 0.8m in height wooden table. For floor-standing equipment, the EUT and all cables were insulated, if required, from the ground plane by up to 12 mm of insulating material. The EUT was adjusted to maintain a 0.4 meter space from a vertical reference plane. The EUT was connected to power mains through a line impedance stabilization network (LISN), which provided 50 ohm coupling impedance for measuring instrument and the chassis ground was bounded to the horizontal ground plane of shielded room. The excess power cable between the EUT and the LISN was bundled.

All connecting cables of EUT and peripherals were moved to find the maximum emission.

8.4.3 Conducted Emission Test Setup

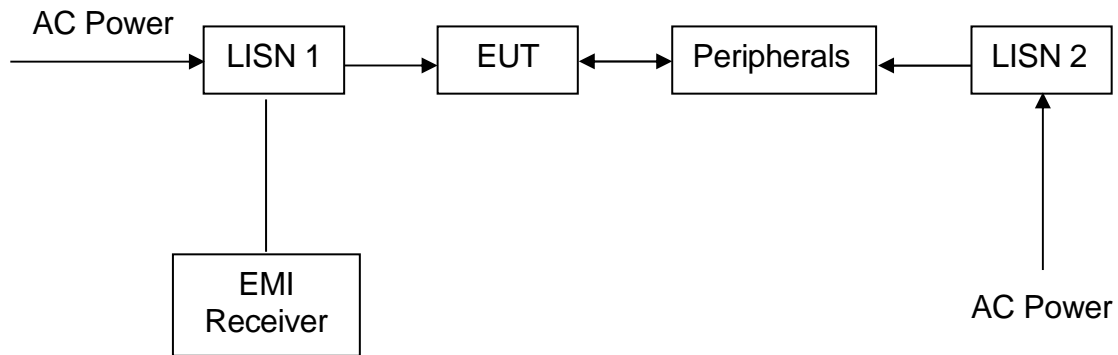

TEST REPORT

9.0 CONFIDENTIALITY REQUEST

For electronic filing, a preliminary copy of the confidentiality request is saved with filename: request.pdf.

10.0 EQUIPMENT LIST

1) Radiated Emissions Test

Equipment	EMI Test Receiver	Spectrum Analyzer	Biconical Antenna (20MHz to 200MHz)
Registration No.	EW-3156	EW-2466	EW-2512
Manufacturer	ROHDESCHWARZ	ROHDESCHWARZ	EMCO
Model No.	ESR26	FSP30	3104C
Calibration Date	January 25, 2021	November 18, 2019	June 03, 2020
Calibration Due Date	January 25, 2022	August 18, 2022	December 03, 2021

Equipment	Log Periodic Antenna	Double Ridged Guide Antenna	Active Loop H-field (9kHz to 30MHz)
Registration No.	EW-3243	EW-1133	EW-2313
Manufacturer	EMCO	EMCO	ELECTROMETRI
Model No.	3148B	3115	EM-6876
Calibration Date	June 30, 2021	June 03, 2021	December 17, 2019
Calibration Due Date	December 30, 2022	June 03, 2022	December 17, 2021

Equipment	RF Preamplifier (9kHz to 6000MHz)	2.4GHz Notch Filter	14m Double Shield RF Cable (20MHz to 6GHz)
Registration No.	EW-3006b	EW-3435	EW-2074
Manufacturer	SCHWARZBECK	MICROWAVE	RADIALL
Model No.	BBV9718	N0324413	N(m)-RG142-BNC(m) L=14M
Calibration Date	November 25, 2019	November 16, 2019	November 14, 2019
Calibration Due Date	June 25, 2022	June 16, 2022	August 14, 2022

Equipment	Pyramidal Horn Antenna
Registration No.	EW-0905
Manufacturer	EMCO
Model No.	3160-09
Calibration Date	July 20, 2021
Calibration Due Date	January 20, 2023

TEST REPORT

2) Conducted Emissions Test

Equipment	RF Cable 240cm (RG142) (9kHz to 30MHz)	Artificial Mains Network	EMI Test Receiver
Registration No.	EW-2454	EW-2501	EW-2500
Manufacturer	RADIALL	ROHDESCHWARZ	ROHDESCHWARZ
Model No.	Bnc m st / 142 / bnc mra 240cm	ENV-216	ESCI
Calibration Date	November 10, 2020	September 11, 2020	March 29, 2021
Calibration Due Date	December 10, 2021	December 11, 2021	March 29, 2022

3) Bandedge Measurement

Equipment	Spectrum Analyzer	5m RF Cable (40GHz)
Registration No.	EW-2466	EW-2701
Manufacturer	ROHDESCHWARZ	RADIALL
Model No.	FSP30	Sma m-m 5m 40G
Calibration Date	November 18, 2019	November 24, 2020
Calibration Due Date	August 18, 2022	February 24, 2022

END OF TEST REPORT