

DKL1608-S User Manual

FCC ID: SQ9DKL1608 IC: 5768A-DKL1608

1 CONTROL STATES

1.1 POWER-ON RESET

When power is applied to VDD and is over 1.9V threshold, DKL1608-S will run power-on reset. Once power-on reset is completed, the device will be in power-down mode.

1.2 POWER-DOWN MODE

In power-down mode, DKL1608-S is in deep-sleep and only the SPI interface is active. DKL1608-S is in power-down mode when PWR_ON is set to 0.

The device enters power-down mode whenever PWR_ON is set to zero.

1.3 STANDBY MODE

Setting PWR_ON bit to “1” will activate device to standby mode (while CE remains 0). In standby mode, the crystal oscillator is active, and the device is ready to quickly enter TX or RX mode.

1.4 TX MODE

DKL1608-S transmits packets in TX mode. To operate in TX mode, the device needs to be set up as a PTX (RX_ON=0), standby mode (PWR_ON=1), and a payload(s) in FIFO. There are two modes of TX: pulsed (single packet mode) and continuous mode. A CE high pulse of at least 10 us triggers a single packet to be sent. Keeping CE high will set the device to continuous TX mode, which will send out all packets in FIFO. After FIFO is emptied, the device will power-off radio and digital baseband to save current, but the device will commence transmission as soon as a new payload enters FIFO.

When auto-ACK feature is enabled, a PRX device automatically enters TX mode to send back an ACK packet after a valid packet is received from a PTX.

1.5 RX MODE

DKL1608-S receives packets in RX mode. The device needs to be set up as a PRX (RX_ON=1) and in standby mode (PWR_ON=1). Pulling CE pin high sets the device to RX mode and will continue listening for packets as long as CE is held high. Payloads of valid packets will be placed into the RX FIFO.

When auto-ACK feature is enabled, a PTX device automatically enters RX mode after transmission to listen for an ACK packet from the PRX.

1.6 RADIO SETUP

DKL1608-S supports 250kbps, 1Mbps, and 2 Mbps air bit rate. The choice of which bit rate to use depends on range, current consumption, and data rate needed. Lower bit rate has longer range, while higher bit rate has lower current consumption and reduced probability of in-air collision. Air rate is set by the SETUP_RF register.

The channel may be set in 1 MHz increment from 2400 MHz to 2483 MHz. Although it is possible

to set the channel frequency higher than 2483 MHz, it is not recommended for this may violate regional regulations. For 250kbps and 1Mbps operation, the channel may be set in 1 MHz increment; for 2Mbps operation, the channel spacing should be 2 MHz or more. Channel selection is set by the RF_CH register.

In addition to the device address, the bit rate and channel frequency need to be set the same for the radios to communicate with each other.

1.7 RSSI RECORDER

DKL1608-S features an advanced RSSI block and control, allowing the receiver host to collect detailed information of the current RX channel. There are two decision thresholds that can be individually set. An RSSI recorder generates a log of the channel traffic. With two decision thresholds, the host can separate the receiving signal into three ranges: low, medium, and high. The RSSI recorder consists of two 8-bit shift registers corresponding to the two thresholds, and it keeps track of the RSSI readings for the past 8 time slots. A single time slot is 128 us. The most recent RSSI record is placed at the MSB of the shift register, and the bits are shifted toward LSB as time progresses. This recording RSSI scheme can be useful in detecting complex channel behaviors such as fading, interference, and may assist MCU in channel selection.

The RSSI enable setting and RSSI readout are in the RSSI register setting. The RSSI threshold and recorder are in address 0x18. Figure 6 shows the basic concept of the RSSI recorder scheme. At read point 1, [RSSI1, RSSI2] readout will be [0, 0], RSSIREC1 readout will be 0x1F and RSSIREC2 readout will be 0x06; at read point 2, [RSSI1, RSSI2] will read [0, 1], RSSIREC1 will read 0xF0 and RSSIREC2 will read 0x10.

DKL1608-S also has a unique identifier encoded in [RSSIREC2, RSSIREC1] and can be read right after POR. The 16-bit unique ID for DKL1608-S is 0x7241.

To save current, the RSSI is set to be off by default. To turn on the RSSI, enable bit 4 of the RSSI register. The two decision thresholds are also indicated at bit 0 and bit 1 of the RSSI register.

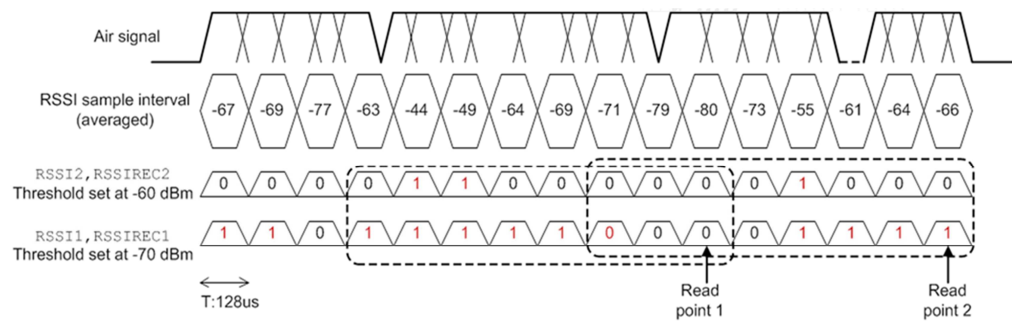

RSSI recorder scheme

2 PACKET INFORMATION

2.1 PACKET FORMAT

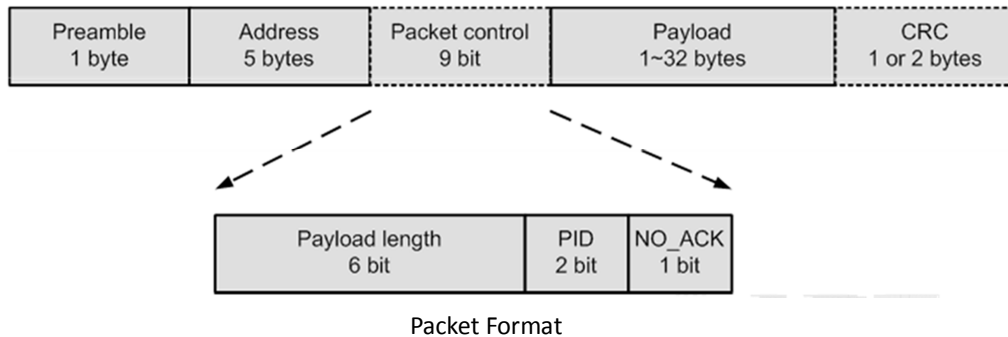

The packet consists of 5 portions: preamble, address, packet control, payload, and CRC. The preamble, address, and payload are required fields; packet control and CRC are optional fields, depending on settings.

2.2 PREAMBLE

The preamble is a one-byte alternating sequence of 01010101 or 10101010, depending on the first bit in the address. If the first address bit is 1 the preamble will be set to 10101010; if the first address bit is 0, the preamble is set to 01010101.

2.3 ADDRESS

This field holds the address of the receiver.

Addresses with only one or two transitions (e.g. 0x000005FFFF or 0x00FF000000) or as a continuation of the preamble (010101.) are not recommended for they may increase the packet error rate.

2.4 PACKET CONTROL

The packet control field consists of 9 bits, containing a 6-bit payload length field, a 2-bit packet identity (PID) field, and a one-bit NO_ACK flag.

The payload length is used when dynamic payload length feature is enabled. It specifies payload length in bytes, which can range from 1 to 32. Values higher than 32 are ignored.

The PID field is used to detect whether the packet is new or retransmitted. This field prevents the PRX from delivering the same payload more than once to the RX host MCU. The PID is incremented at the TX side for each new packet received through the SPI. The PID and CRC fields are used together by the PRX to determine whether the received packet is retransmitted or new.

The NO_ACK flag is used when the auto-ACK feature is enabled. Setting the flag high tells the receiver that this packet does not need to be auto acknowledged. This flag is set on the PTX by using the command W_TX_PLOAD_NOACK, instead of W_TX_PLOAD, to write the TX payload. To use this function requires enabling the EN_DYN_ACK bit in the FEATURE register. When this option is used to transmit, the PTX goes directly to standby mode after transmitting the packet, and the PRX will not transmit an ACK packet after the packet is received.

2.5 PAYLOAD

The payload can be 1 to 32 bytes wide. The payload can be set either static or dynamic in length, defined by the packet control field. The default setup is static payload length. The static payload length is set by the RX_PW_Px register on the receiver side. Payload length on the transmitter side is set by the number of bytes placed in the TX_FIFO and must be equal to the value set in the RX_PW_Px register on the receiver side.

Dynamic payload length enables the transmitter to send packets of variable length to the receiver. The receiver can decode the payload length automatically from the control field value. The MCU can read the received payload length by using R_RX_PL_WID command.

To enable dynamic payload, set the EN_DPL bit in the FEATURE register to 1. In RX mode, the DYNPD register must be set. A PTX that transmits to a PRX with dynamic payload enabled must have the DPL_P0 bit in DYNPD set.

2.6 CYCLIC REDUNDANCY CHECK (CRC)

The CRC is an error detection mechanism in the packet. It can be set to 1 or 2 bytes and is calculated over the address, packet control field, and payload.

The polynomial for 1-byte CRC is $X^8 + X^2 + X + 1$, with an initial value of 0xFF.

The polynomial for 2-byte CRC is $X^8 + X^2 + X + 1$, with an initial value of 0xFFFF.

The CRCC bit in the CFG_TOP register sets the CRC length, and EN_CRC controls whether CRC is used. The CRC is a mandatory field for packets with auto-ACK or dynamic payload length enabled, and will override the EN_CRC bit setting. If CRC is enabled, packets will be dropped if CRC fails.

2.7 PACKET HANDLING

In TX mode, the PHY engine fetches a payload from TX FIFO, assembles the payload into a packet and transmits the packet in a short burst. After transmission, if the PTX packet has the NO_ACK flag set, the device sets TX_DS to 1 and gives an active low interrupt IRQ to MCU. If the PTX packet is an auto-ACK one, the PTX needs to receive an ACK from the PRX and then asserts the TX_DS IRQ.

The receiver continuously listens to the air channel for radio signal, and once it is synchronized to a likely signal, the PHY engine will validate the address and CRC of the possible packet. If a valid packet is detected and is a new one, the PHY engine writes the payload to RX FIFO, sets RX_DR to 1 and gives an active low interrupt IRQ to MCU.

When auto-acknowledge is enabled (EN_AA=1), the PTX will enter RX mode after transmission to wait for an ACK packet. If an ACK is not received within delay set by ARD[3:0], the PTX re-transmits the original packet and enters RX mode to wait for ACK. The above action is repeated until an ACK packet is received or the number of re-transmission exceeds a threshold set by ARC[3:0]. If the latter threshold is met, the PTX will set MAX_RT to 1 and give an active low interrupt IRQ to MCU. Two packet loss counters (ARC_CNT and PLOS_CNT) are incremented each time a packet is lost. The ARC_CNT counts the number of retransmissions for the current transaction. The PLOS_CNT counts the total number of retransmissions since the last channel change. Initiating a new transmission resets the ARC_CNT. Writing to the RF_CH register resets the PLOS_CNT. The ARC_CNT and the PLOS_CNT are in the OBSERVE_TX register. They may be

used as an indicator of overall channel quality.

The PTX device will retransmit if its RX FIFO is full but receives an ACK packet with payload. As an alternative for the PTX to auto retransmit, it is possible to manually set the device to retransmit a packet a number of times. This is done by the REUSE_TX_PL command.

When auto-ACK is enabled, it is possible for the PRX to send a payload along with the ACK packet. To use this feature, the EN_ACK_PAY bit in the FEATURE register needs to be set. In addition, the dynamic payload function also needs to be set. The MCU at the PRX needs to upload the payload to the PRX's TX FIFO by using the W_ACK_PAYLOAD command. Payloads pending in the TX FIFO (of the PRX) will be sent after a new packet is received from PTX. Up to three payloads may be pending in the TX FIFO (of the PRX) at the same time.

3 DATA AND CONTROL INTERFACE

3.1 TX AND RX FIFO

DKL1608-S has three levels of FIFO for the transmitter, and three levels of FIFO for receiver. Each FIFO level is 32 bytes in length. The TX FIFO is used to store payloads that are to be transmitted, and the RX FIFO is used to store the received payloads that have not been downloaded by the host MCU. Up to three payloads may be stored in a TX FIFO, and up to three payloads may be stored in an RX FIFO. The RX FIFO will also record which data pipe the payload comes from. Data pipe information is in the STATUS register and is read out from SDO during every SPI command. Successful transmission of a payload will clear a slot in the TX FIFO, and a reading from RX FIFO will clear an RX payload slot. Both FIFOs are accessed through the SPI using dedicated commands. Data access to the two FIFOs, as the name suggests, follows the first-in first-out principle.

In a PRX device, the TX FIFO can store payloads of ACK packets for up to three different PTX devices. The TX FIFO in a PRX may be filled up and blocked if all pending payloads are addressed to the pipe where the link to the PTX is lost. In this case, the MCU should flush the TX FIFO by using the FLUSH_TX command.

The TX FIFO may be accessed using three different commands: W_TX_PLOAD, W_ACK_PLOAD, and W_TX_PLOAD_NOACK. All three commands access the same TX FIFO. The description of the commands is detailed in the SPI Command section. The RX FIFO is accessed by the command R_RX_PLOAD, and it may be accessed in both PTX and PRX mode. The payload width of the top slot in RX FIFO is read by the command R_RX_PL_WID.

The statuses of the TX FIFO and RX FIFO are in the STATUS_FIFO register. The device may also be configured to read out the STATUS_FIFO register during every command by adjusting the STAT_SETUP setting in FEATURE register.

The device may retransmit its last transmitted payload by the command REUSE_TX_PL and pulsing the CE pin to trigger transmission. Payload reuse will remain active until W_TX_PLOAD or FLUSH_TX command is executed.

3.2 INTERRUPT

DKL1608-S's pin 6 is an active-low interrupt pin, used to inform host MCU of various events.

Interrupt is activated when the TX_DS, RX_DR, or MAX_RT in the STATUS register is set high. The IRQ pin is reset when the host writes “1” to the IRQ source bit in the STATUS register. In the CONFIG register, there are three mask bits, which may be used to set which event triggers the IRQ pin. By default all IRQ sources are enabled.

Please note that the 3-bit pipe information in the STATUS register is updated during the IRQ pin transition. The pipe information is unreliable if the STATUS register is read during the IRQ pin high-to-low transition.

3.3 STAR CONNECTION

DKL1608-S may be configured as a PRX receiving from up to 6 PTX devices, forming a star network. Once configured, the connections are presented as different data pipes to the PRX host.

The following settings are common to all data pipes:

- CRC on/off (always enabled when using auto-ACK or dynamic payload)
- CRC setting (1 or 2 bytes)
- RX address width
- Frequency channel
- Air data rate

Data pipes are enabled with the EN_RXADDR register. By default data pipe 0 and 1 are enabled. Data pipe addresses are configured in the RX_ADDR_PX register, where “X” is from 0 to 5. Each data pipe should have a unique address. Data pipe 0 has a unique address.

Addresses of data pipes 1 to 5 differ only by the LSByte.

During a star connection, since the PRX device will be transmitting ACK packets to different PTX devices, to identify the correct destination, the PRX device uses the RX address of the particular pipe as the packet address when sending ACK packets. Therefore for the PTX devices, their RX address needs to be set the same as their TX address. Furthermore, since all data pipes operate at the same channel frequency, only one data pipe should be active at any time. When multiple PTXs are transmitting to a PRX, the ARD may be set at different values so that collisions happen only once.

3.4 SPI COMMAND

DKL1608-S is controlled by a standard SPI interface. All commands must be initiated by a high to low transition on pin CSN.

The status of the chip is shifted out on the SDO pin simultaneously as the SPI command word is serially fed into the SDI pin. Typically the status output is the STATUS register bits, but it can be configured to report RX status or FIFO status. The output of the SDO pin is set by the STAT_SETUP in the FEATURE register.

The SPI command format consists of an 8-bit command word (from MSB to LSB) followed by the data in bytes. Data bytes are fed from LSByte to MSByte, and start with the MSBit in each byte first.

The R_REG and W_REG commands operate on single or multi-byte registers. When accessing multi-byte registers, writing of bytes may be terminated before all bytes are written, leaving

unwritten MSByte(s) unchanged.

Note: The 3 bit pipe information in the STATUS register is updated when IRQ pin changes from high to low. Therefore, the pipe information is unreliable if the STATUS register is read during an IRQ transition.

Table 1: SPI Commands

Command name	Command word (binary)	Number of data bytes	Description
R_REG	000X XXXX	1 to 5	Read registers. XXXXX is the 5-bit register address
W_REG	001Y YYYY	1 to 5	Write to registers. YYYYY is the 5-bit register address. Executable in power-down or standby mode only
R_RX_PLOAD	0110 0001	1 to 32	Read RX payload. Read operation always starts at byte 0. Payload is deleted from FIFO after it is read. Used in RX mode.
W_TX_PLOAD	1010 0000	1 to 32	Write TX payload. Write operation always starts at byte
FLUSH_TX	1110 0001	0	Flush TX FIFO, used in TX mode
FLUSH_RX	1110 0010	0	Flush RX FIFO, used in RX mode If used during transmission of acknowledgement, acknowledgement packet will not be completed.
REUSE_TX_PL	1110 0011	0	Used for a PTX device. Reuse last transmitted payload. TX payload reuse is active until W_TX_PLOAD or FLUSH_TX is executed. TX payload reuse must not be activated or deactivated during packet transmission.

R_RX_PL_WID	0110 0000	1	Read RX payload width of the top R_RX_PLOAD in the RX FIFO. * If read value is larger than 32 bytes, then FLUSH_RX.
W_ACK_PLOAD	1010 1ZZZ	1 to 32	Used in RX mode. Write payload to be transmitted w/ ACK packet on pipe ZZZ. (ZZZ is from 000 to 101) Maximum of three ACK
W_TX_PLOAD_NOACK	1011 0000	1 to 32	Used in TX mode. Disable auto- ACK for this specific packet
NOP	1111 1111	0	No operation. May be used to read status register without giving specific command

SPI Timing

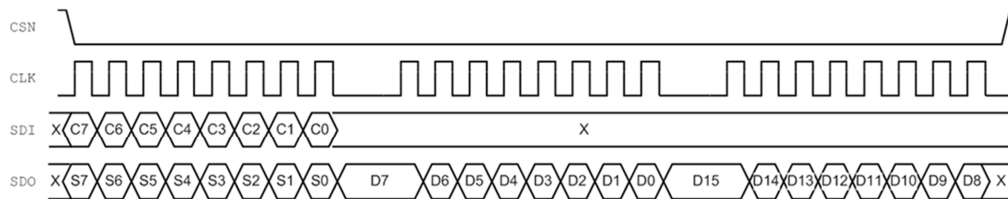

SPI Read Command

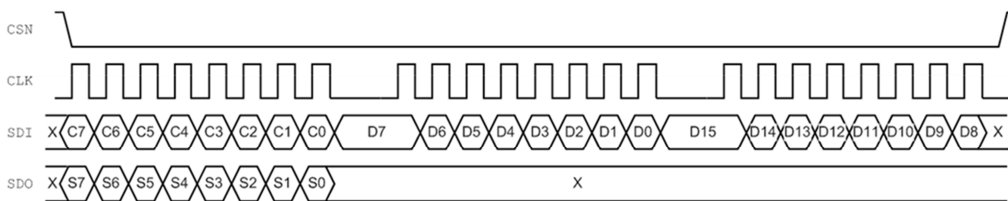

SPI Write Command

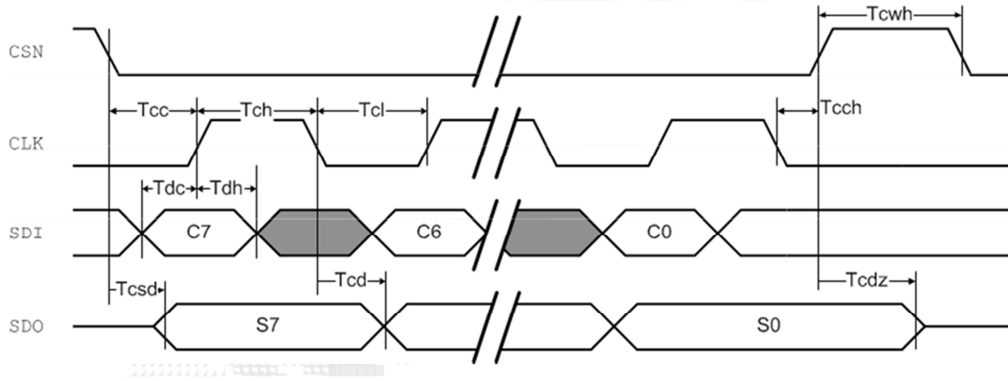

SPI NOP Command

Table2: SPI Timing

Symbol	Parameters	Minimum	Maximum	Units
Tdc	Data to CLK setup	3		n
Tdh	CLK to data hold	3		n
Tcsd	CSN to data valid		38	n
Tcd	CLK to data valid		55	n
Tcl	CLK low time	40		n
Tch	CLK high time	40		n
FCLK	CLK frequency	0	10	MH
Tr/Tf	CLK rise & fall time		100	n
Tcc	CSN to CLK setup	3		n
Tcch	CLK to CSN hold	3		n
Tcwh	CSN inactive time	50		n
Tcdz	CSN to output high Z		38	n

3.5 SDO STATUS READOUT

By default the SDO will readout the STATUS register during every SPI command input. A feature of DKL1608-S is that the SDO readout may be set to “RX” focused readout or “FIFO” readout. The SDO readout is set by STAT_SETUP in the FEATURE register. When the register is set to RX readout mode, the positions of MAX_RT and TX_FULL are replaced by RSSI2 and RSSI1. In FIFO readout mode, SDO will read out STATUS_FIFO instead of the STATUS register.

4 REGISTER MAP TABLE

Addresses 0x19, 0x1A, 0x1B, and 0x1F are reserved for test purposes and performance tuning. Altering them to values other than their POR values may result in chip malfunction.

Reserved bits that are labeled “Unused” do not have any function. Reserved bits that are labeled “Only ‘0’ allowed” are not to be changed. Modifications to such reserved bits may result in chip malfunction.

Address (hex)	Name	Bit	Reset value	Type	Description
---------------	------	-----	-------------	------	-------------

00	CFG_TOP				Top-level configuration
	Reserved	7	0	R/W	Must be 0 for normal operation
	MASK_RX_DR	6	0	R/W	Mask interrupt caused by RX_DR; 1: interrupt not reflected on IRQ pin; 0: reflect RX_DR as active low interrupt on
	MASK_TX_DS	5	0	R/W	Mask interrupt caused by TX_DS; 1: interrupt not reflected on IRQ pin; 0: reflect TX_DS as active low interrupt on IRQ pin
	MASK_MAX_RT	4	0	R/W	Mask interrupt caused by MAX_RT; 1: interrupt not reflected on IRQ pin; 0: reflect MAX_RT as active low interrupt on IRQ pin
	EN_CRC	3	1	R/W	Enable CRC. Forced high if any of the bits in EN_AA is high
	CRCC	2	0	R/W	CRC scheme 0: 1 byte, 1: 2 bytes
	PWR_ON	1	0	R/W	1: power-up, 0, power-down
	RX_ON	0	0	R/W	1: PRX, 0: PTX
01	EN_AA				Auto-acknowledgement settings
	Reserved	7:6	0	R/W	Unused
	ENAA_P5	5	1	R/W	Enable AA on data pipe 5
	ENAA_P4	4	1	R/W	Enable AA on data pipe 4
	ENAA_P3	3	1	R/W	Enable AA on data pipe 3
	ENAA_P2	2	1	R/W	Enable AA on data pipe 2
	ENAA_P1	1	1	R/W	Enable AA on data pipe 1
	ENAA_P0	0	1	R/W	Enable AA on data pipe 0
02	EN_RXADDR				Enable RX addresses
	Reserved	7:6	0	R/W	Unused

	ENRX_P5	5	0	R/W	Enable data pipe 5
	ENRX_P4	4	0	R/W	Enable data pipe 4
	ENRX_P3	3	0	R/W	Enable data pipe 3
	ENRX_P2	2	0	R/W	Enable data pipe 2
	ENRX_P1	1	1	R/W	Enable data pipe 1
	ENRX_P0	0	1	R/W	Enable data pipe 0
03	SETUP_AW				Address width & timing setup
	Reserved	7:4	0	R/W	Unused
	Reserved	3:2	11	R/W	Reserved setting, must be set to 11
	Reserved	1:0	11	R/W	Reserved setting, must be set to 11
04	SETUP_RETR				Automatic retransmission setup
	ARD[3:0]	7:4	0000	R/W	Automatic retransmission delay 0000: wait 250uS 0001: wait 500uS
	ARC[3:0]	3:0	0011	R/W	Auto retransmit count 0000: disabled 0001: up to 1 re-transmit on fail of
05	RF_CH				RF channel
	Reserved	7	0	R/W	Unused
	RF_CH[6:0]	6:0	0x02	R/W	Set frequency channel in 1 MHz increment, 0x00 is 2400 MHz
06	SETUP_RF				RF settings
	EN_CW	7	0	R/W	Enable continuous carrier when set high Confirm during chip verification
	EN_PRBS	6	0	R/W	Enable PRBS bit stream when set high; EN_CW also needs to be enabled
	RF_DR_LOW	5	0	R/W	See RF_DR_HIGH

	TX_ATTEN	4	0	R/W	TX low-power mode Confirm actual attenuation level
	RF_DR_HIGH	3	0	R/W	[RF_DR_LOW, RF_DR_HIGH] 00: 1Mbps 01: 2Mbps
	RF_PWR[1:0]	2:1	01	R/W	Set RF output power in TX mode 00: -18 dBm 01: -12 dBm
	Reserved	0	0	R/W	Unused
07	STATUS				Status (read-out from SDO pin during SPI command word input); SDO output may be adjusted
	Reserved	7	0	R/W	Unused
	RX_DR	6	0	R/W	Data ready RX FIFO interrupt. Asserted when new data arrives at RX FIFO. Write 1 to clear bit
	TX_DS	5	0	R/W	Data sent TX FIFO interrupt. Asserted when packet transmitted. If auto-ACK is activated, this bit is set high
	MAX_RT	4	0	R/W	Maximum number of TX retransmit interrupt. Write 1 to clear bit. If MAX_RT is asserted it must be cleared to enable
	RX_P_NO[2:0]	3:1	111	R	Data pipe number for the payload available for reading from RX_FIFO 000~101: data pipe number (0~5)
	TX_FULL	0	0	R	0: TX FIFO available 1: TX FIFO full
08	OBSERVE_TX				Transmission observation
	PLOS_CNT[3:0]	7:4	0000	R	Count lost packets. Overflow protected to 15, and stops at maximum value until reset. Counter reset by writing to RF_CH
	ARC_CNT[3:0]	3:0	0000	R	Count retransmitted packets. Counter resets when transmission of a new packet starts
09	RSSI				TSSI and RSSI indicator/control
	Reserved	7	0	R/W	Must be 0 for normal operation
	Reserved	6	0	R/W	Must be 0 for normal operation
	Reserved	5	0	R/W	Must be 0 for normal operation

	EN_RSSI	4	0	R/W	Enable RSSI
	Reserved	3	0	R	Reserved register readout
	Reserved	2	0	R	Reserved register readout
	RSSI2	1	0	R	RSSI indicator at threshold 2
	RSSI1	0	0	R	RSSI indicator at threshold 1
0A	RX_ADDR_P0	39:0	0xE7 E7E7 E7E7	R/W	RX address data pipe 0. 5 bytes maximum. LSB byte written first. Number of bytes used set by SETUP_AW.
0B	RX_ADDR_P1	39:0	0xC2 C2C2 C2C2	R/W	RX address data pipe 1. 5 bytes maximum. LSB byte written first. Number of bytes used set by SETUP_AW.
0C	RX_ADDR_P2	7:0	0xc3	R/W	RX address data pipe 2. Only LSB are set, MSB bytes use RX_ADDR_P1[39:8]
0D	RX_ADDR_P3	7:0	0xc4	R/W	RX address data pipe 3. Only LSB are set, MSB bytes use RX_ADDR_P1[39:8]
0E	RX_ADDR_P4	7:0	0xc5	R/W	RX address data pipe 4. Only LSB are set, MSB bytes use RX_ADDR_P1[39:8]
0F	RX_ADDR_P5	7:0	0xc6	R/W	RX address data pipe 5. Only LSB are set, MSB bytes use RX_ADDR_P1[39:8]
10	TX_ADDR	39:0	0xE7 E7E7 E7E7	R/W	TX address. Used for PTX only. Set RX_ADDR_P0 equal to this address to handle auto acknowledgement
11	RX_PW_P0				
	Reserved	7:6	00	R/W	Unused
	RX_PW_P0	5:0	0	R/W	Number of bytes in RX payload in data pipe 0 (1 to 32). 0: pipe not used
12	RX_PW_P1				
	Reserved	7:6	00	R/W	Unused
	RX_PW_P1	5:0	0	R/W	Number of bytes in RX payload in data pipe 1 (1 to 32). 0: pipe not used
13	RX_PW_P2				
	Reserved	7:6	00	R/W	Unused
	RX_PW_P2	5:0	0	R/W	Number of bytes in RX payload in data pipe 2 (1 to 32). 0: pipe not used
14	RX_PW_P3				

	Reserved	7:6	00	R/W	Unused
	RX_PW_P3	5:0	0	R/W	Number of bytes in RX payload in data pipe 3 (1 to 32). 0: pipe not used
15	RX_PW_P4				
	Reserved	7:6	00	R/W	Unused
	RX_PW_P4	5:0	0	R/W	Number of bytes in RX payload in data pipe 4 (1 to 32). 0: pipe not used
16	RX_PW_P5				
	Reserved	7:6	00	R/W	Unused
	RX_PW_P5	5:0	0	R/W	Number of bytes in RX payload in data pipe 5 (1 to 32). 0: pipe not used
17	STATUS_FIFO				FIFO status
	Reserved	7	0	R/W	Unused
	TX_REUSE	6	0	R	Used for a PTX device Pulse the rfce high for at least 10µs to Reuse last
	TX_FULL	5	0	R	1: TX FIFO full 0: available slots in TX FIFO
	TX_EMPTY	4	1	R	1: TX FIFO empty 0: data in TX FIFO
	Reserved	3:2	0	R	Reserved register readout
	RX_FULL	1	0	R	1: RX FIFO full 0: available slots in RX FIFO
	RX_EMPTY	0	1	R	1: RX FIFO empty 0: RX FIFO full
18	RSSIREC				RSSI recorder feature
	Reserved	31:26	111	W	Reserved
	Reserved	25:22	0110	R	Reserved
	RSSI2_VREF_SEL[2:0]	21:19	000	W	RX RSSI VREF2 setting 000: -59 dBm, +4dB/step 111: out of range
	RSSI1X_VREF_SEL[2:0]	18:16	000	W	RX RSSI VREF1 setting 000:-69 dBm, +4dB/step

	RSSIREC2[7:0]	15:8	01110010	R	RSSI2 recorder, MSB is most recent recording, any write command on this register will flush RSSI setting; when
	RSSIREC1[7:0]	7:0	01000001	R	RSSI1 recorder, MSB is most recent recording, any write command on this register will flush RSSI setting; when
1C	DYNPD				Dynamic payload length
	Reserved	7:6	00	R/W	Unused
	DPL_P5	5	0	R/W	Set 1 to enable dynamic payload length data pipe 5 (requires EN_DPL & ENAA_P5)
	DPL_P4	4	0	R/W	Set 1 to enable dynamic payload length data pipe 4 (requires EN_DPL & ENAA_P4)
	DPL_P3	3	0	R/W	Set 1 to enable dynamic payload length data pipe 3 (requires EN_DPL & ENAA_P3)
	DPL_P2	2	0	R/W	Set 1 to enable dynamic payload length data pipe 2 (requires EN_DPL & ENAA_P2)
	DPL_P1	1	0	R/W	Set 1 to enable dynamic payload length data pipe 1 (requires EN_DPL & ENAA_P1)
	DPL_P0	0	0	R/W	Set 1 to enable dynamic payload length data pipe 0 (requires EN_DPL & ENAA_P0)
1D	FEATURE				Features
	STAT_SETUP[1:0]	7:6	00	R/W	Adjust the output of SDO during command input
					00: default, SDO output is STATUS 01: RX readout mode, the SDO output MAX_RT and TX_FULL bit is replaced by
	Reserved	5:3	000	R/W	Unused
	EN_DPL	2	0	R/W	Set 1 enables dynamic payload length
	EN_ACK_PAY	1	0	R/W	Set 1 enables payload on ACK
	EN_DYN_ACK	0	0	R/W	Set 1 enables the W_TX_PAYLOAD_NOACK command
1F	RESERVED				Reserved register
	Reserved	7:0	0	R/W	8'h00: default settings