



# FCC TEST REPORT

**REPORT NO. :** RF931123L11B

**MODEL NO. :** IT7000

**OEM MODEL NO. :** DLI7000; CX1100

**RECEIVED :** NA

**TESTED :** Dec. 08 ~ Dec. 24, 2004

**ISSUED :** Jan. 07, 2005

**APPLICANT :** BITATEK CO., LTD.

**ADDRESS :** 6F-1, 190, Ta-Tung Road, Sec. 3, Hsichih 221,  
Taipei County, Taiwan, R.O.C.

**ISSUED BY :** Advance Data Technology Corporation

**LAB ADDRESS :** No. 47, 14th Ling, Chia Pau Tsuen, Lin Kou Hsiang  
244, Taipei Hsien, Taiwan, R.O.C.

**TEST LOCATION :** No. 19, Hwa Ya 2nd Rd., Wen Hwa Tsuen, Kwei  
Shan Hsiang, Taoyuan Hsien 333, Taiwan, R.O.C.

This test report consists of 71 pages in total. It may be duplicated completely for legal use with the approval of the applicant. It should not be reproduced except in full, without the written approval of our laboratory. The client should not use it to claim product endorsement by CNLA, A2LA or any government agencies. The test results in the report only apply to the tested sample. The test results in this report are traceable to the national or international standards.



No. 2177-01



0528  
ILAC MRA



## Table of Contents

1	CERTIFICATION.....	5
2	SUMMARY OF TEST RESULTS .....	6
2.1	MEASUREMENT UNCERTAINTY .....	6
3	GENERAL INFORMATION .....	7
3.1	GENERAL DESCRIPTION OF EUT .....	7
3.2	DESCRIPTION OF TEST MODES .....	8
3.3	DESCRIPTION OF APPLIED STANDARDS.....	9
3.4	DESCRIPTION OF SUPPORT UNITS .....	10
3.5	CONFIGURATION OF SYSTEM UNDER TEST .....	10
4	TEST TYPES AND RESULTS .....	12
4.1	CONDUCTED EMISSION MEASUREMENT.....	12
4.1.1	LIMITS OF CONDUCTED EMISSION MEASUREMENT .....	12
4.1.2	TEST INSTRUMENTS.....	12
4.1.3	TEST PROCEDURES .....	13
4.1.4	DEVIATION FROM TEST STANDARD.....	13
4.1.5	TEST SETUP.....	14
4.1.6	EUT OPERATING CONDITIONS .....	14
4.1.7	TEST RESULTS (A).....	15
4.1.8	TEST RESULTS (B).....	21
4.2	RADIATED EMISSION MEASUREMENT.....	27
4.2.1	LIMITS OF RADIATED EMISSION MEASUREMENT .....	27
4.2.2	TEST INSTRUMENTS.....	28
4.2.3	TEST PROCEDURE.....	29
4.2.4	DEVIATION FROM TEST STANDARD.....	29
4.2.5	TEST SETUP.....	30
4.2.6	EUT OPERATING CONDITIONS .....	30
4.2.7	TEST RESULTS (A).....	31
4.2.8	TEST RESULTS (B).....	33
4.2.9	TEST RESULTS (C) .....	35
4.2.10	TEST RESULTS .....	37
4.3	NUMBER OF HOPPING FREQUENCY USED .....	40
4.3.1	LIMITS OF HOPPING FREQUENCY USED .....	40
4.3.2	TEST INSTRUMENTS.....	40
4.3.3	TEST PROCEDURE.....	40



4.3.4	DEVIATION FROM TEST STANDARD.....	40
4.3.5	TEST SETUP.....	41
4.3.6	TEST RESULTS .....	41
4.4	DWELL TIME ON EACH CHANNEL.....	43
4.4.1	LIMITS OF DWELL TIME USED.....	43
4.4.2	TEST INSTRUMENTS.....	43
4.4.3	TEST PROCEDURE.....	43
4.4.4	DEVIATION FROM TEST STANDARD.....	44
4.4.5	TEST SETUP.....	44
4.4.6	TEST RESULTS .....	44
4.5	CHANNEL BANDWIDTH.....	48
4.5.1	LIMITS OF CHANNEL BANDWIDTH.....	48
4.5.2	TEST INSTRUMENTS.....	48
4.5.3	TEST PROCEDURE.....	48
4.5.4	DEVIATION FROM TEST STANDARD.....	48
4.5.5	TEST SETUP.....	49
4.5.6	EUT OPERATING CONDITION.....	49
4.5.7	TEST RESULTS .....	50
4.6	HOPPING CHANNEL SEPARATION.....	53
4.6.1	LIMITS OF HOPPING CHANNEL SEPARATION .....	53
4.6.2	TEST INSTRUMENTS.....	53
4.6.3	TEST PROCEDURE.....	53
4.6.4	DEVIATION FROM TEST STANDARD.....	53
4.6.5	TEST SETUP.....	54
4.6.6	TEST RESULTS .....	54
4.7	MAXIMUM PEAK OUTPUT POWER.....	57
4.7.1	LIMITS OF MAXIMUM PEAK OUTPUT POWER MEASUREMENT .....	57
4.7.2	TEST INSTRUMENTS.....	57
4.7.3	TEST PROCEDURE.....	57
4.7.4	DEVIATION FROM TEST STANDARD.....	57
4.7.5	TEST SETUP.....	58
4.7.6	TEST RESULTS .....	58
4.8	BAND EDGES MEASUREMENT .....	61
4.8.1	LIMITS OF BAND EDGES MEASUREMENT .....	61
4.8.2	TEST INSTRUMENTS.....	61
4.8.3	TEST PROCEDURE.....	61
4.8.4	DEVIATION FROM TEST STANDARD.....	61



4.8.5	EUT OPERATING CONDITION.....	61
4.8.6	TEST RESULTS .....	62
5	PHOTOGRAPHS OF THE TEST CONFIGURATION .....	66
6	INFORMATION ON THE TESTING LABORATORIES.....	71



## 1 CERTIFICATION

**PRODUCT:** PDT ( Portable Data Terminal )  
**BRAND NAME:** Bitatek  
**OEM BRAND NAME:** TXCOM; Data Ltd; C2E FZ LLC  
**MODEL NO:** IT7000  
**OEM MODEL NO.:** DLI7000; CX1100  
**TEST SAMPLE:** ENGINEERING SAMPLE  
**APPLICANT:** BITATEK CO., LTD.  
**STANDARDS:** FCC Part 15, Subpart C (Section 15.247)  
ANSI C63.4:2003

The above equipment (Model: IT7000) has been tested by **Advance Data Technology Corporation**, and found compliance with the requirement of the above standards. The test record, data evaluation & Equipment Under Test (EUT) configurations represented herein are true and accurate accounts of the measurements of the sample's EMC characteristics under the conditions specified in this report.

**PREPARED BY :** Andrea Hsia , **DATE:** Jan. 07, 2005  
(Andrea Hsia)

**TECHNICAL**  
**ACCEPTANCE :** Gary Chang , **DATE:** Jan. 07, 2005  
Responsible for RF (Gary Chang)

**APPROVED BY :** Cody Chang , **DATE:** Jan. 07, 2005  
(Cody Chang, Deputy Manager)

## 2 SUMMARY OF TEST RESULTS

The EUT has been tested according to the following specifications:

APPLIED STANDARD: FCC Part 15, Subpart C			
Standard Section	Test Type and Limit	Result	Remark
15.207	AC Power Conducted Emission	PASS	Meet the requirement of limit Minimum passing margin is -16.46dB at 0.166MHz
15.247 (a) (1) (iii)	Number of Hopping Frequency Used Spec.: At least 15 channels	PASS	Meet the requirement of limit
15.247 (a) (1) (iii)	Dwell Time on Each Channel Spec.: Max. 0.4 second within 31.6 second	PASS	Meet the requirement of limit
15.247 (a) (1)	Hopping Channel Separation Spec. : Min. 25 kHz or 20 dB bandwidth, which ever is greater	PASS	Meet the requirement of limit
15.247 (a) (1)	Spectrum Bandwidth of a Frequency Hopping Sequence Spread Spectrum System	NA	NA
15.247 (b)	Maximum Peak Output Power Spec.: max. 30dBm	PASS	Meet the requirement of limit
15.247 (d)	Transmitter Radiated Emissions Spec.: Table 15.209	PASS	Meet the requirement of limit Minimum passing margin is -5.96dB at 908.64MHz
15.247 (d)	Band Edge Measurement	PASS	Meet the requirement of limit

### 2.1 MEASUREMENT UNCERTAINTY

Where relevant, the following measurement uncertainty levels have been estimated for tests performed on the EUT as specified in CISPR 16-4:

Measurement	Frequency	Uncertainty
Conducted emissions	9kHz~30MHz	2.44 dB
	30MHz ~ 200MHz	3.63 dB
Radiated emissions	200MHz ~1000MHz	3.65 dB
	1GHz ~ 18GHz	2.20 dB
	18GHz ~ 40GHz	1.88 dB



### 3 GENERAL INFORMATION

#### 3.1 GENERAL DESCRIPTION OF EUT

<b>PRODUCT</b>	PDT ( Portable Data Terminal )
<b>MODEL NO.</b>	IT7000
<b>OEM MODEL NO.</b>	DLI7000; CX1100
<b>POWER SUPPLY</b>	7.4Vdc from rechargeable lithium battery 9Vdc from power adapter
<b>MODULATION TYPE</b>	GFSK for FHSS
<b>TRANSFER RATE</b>	723Kbps
<b>FREQUENCY RANGE</b>	2402MHz ~ 2480MHz
<b>NUMBER OF CHANNEL</b>	79
<b>OUTPUT POWER</b>	0.661mW
<b>ANTENNA TYPE</b>	Chip antenna with -5.2dBi gain
<b>DATA CABLE</b>	1.6m USB shielded cable with 1 core
<b>I/O PORTS</b>	IrDA, USB, serial

**NOTE:**

- The following models are identical to each other except for their model and brand due to marketing requirement.

Brand	Model
Bitatek	IT7000
TXCOM	IT7000
Data Ltd	DLI7000
C2E FZ LLC	CX1100

- The EUT is powered by the following adapter.

<b>Brand</b>	ENG
<b>Model</b>	3A-211DN09
<b>Input Rating</b>	100-240Vac, 50Hz-60Hz, 0.6A
<b>Output Rating</b>	9Vdc, 2.2A
<b>Power Line</b>	DC 1.8m non-shielded cable with 1 core AC 1.8m non-shielded cable without core (3 pin)

- The above EUT information was declared by the manufacturer and for more detailed features description, please refer to the manufacturer's specifications or User's Manual.



### 3.2 DESCRIPTION OF TEST MODES

Since the EUT is considered a portable unit, it was pre-tested on the positioned of each 3 axis. The worst case was found when positioned on Z-plane. Therefore only the test data of this Z-plane was used for radiated test.

There are 3 test results presented in the report as below.

Test Result	Test Condition
A	The EUT was powered by the adapter
B	The EUT connected to the notebook to communicate data and was powered by the adapter
C	The EUT was powered by the battery

79 channels are provided to the EUT for FHSS modulation type.

Channel	Freq. (MHz)	Channel	Freq. (MHz)	Channel	Freq. (MHz)	Channel	Freq. (MHz)
0	2402	20	2422	40	2442	60	2462
1	2403	21	2423	41	2443	61	2463
2	2404	22	2424	42	2444	62	2464
3	2405	23	2425	43	2445	63	2465
4	2406	24	2426	44	2446	64	2466
5	2407	25	2427	45	2447	65	2467
6	2408	26	2428	46	2448	66	2468
7	2409	27	2429	47	2449	67	2469
8	2410	28	2430	48	2450	68	2470
9	2411	29	2431	49	2451	69	2471
10	2412	30	2432	50	2452	70	2472
11	2413	31	2433	51	2453	71	2473
12	2414	32	2434	52	2454	72	2474
13	2415	33	2435	53	2455	73	2475
14	2416	34	2436	54	2456	74	2476
15	2417	35	2437	55	2457	75	2477
16	2418	36	2438	56	2458	76	2478
17	2419	37	2439	57	2459	77	2479
18	2420	38	2440	58	2460	78	2480
19	2421	39	2441	59	2461		

**NOTE:**

1. Below 1 GHz, the channel 0, 39, and 78 were pre-tested in chamber. The channel 0, worst case one, was chosen for final test.
2. Above 1 GHz, the channel 0, 39, and 78 were tested individually.
3. The worst-case data rate on the dwell time on each channel is DH5.





### **3.3 DESCRIPTION OF APPLIED STANDARDS**

The EUT is a PDT ( Portable Data Terminal ) according to the specifications of the manufacturers, it must comply with the requirements of the following standards:

**FCC Part 15, Subpart C (15.247)**

**ANSI C63.4:2003**

All tests have been performed and recorded as per the above standards.

**NOTE:** The EUT is also considered as a kind of computer peripheral, because the connection to computer is necessary for typical use. It has been verified to comply with the requirements of FCC Part 15, Subpart B, Class B. The test report has been issued separately.



### 3.4 DESCRIPTION OF SUPPORT UNITS

The EUT has been tested as an independent unit together with other necessary accessories or support units. The following support units or accessories were used to form a representative test configuration during the tests.

NO.	PRODUCT	BRAND	MODEL NO.	SERIAL NO.	FCC ID
1	NOTEBOOK COMPUTER	DELL	PP05L	12130898320	E2K24CLNS
2	PRINTER	EPSON	LQ-300+	DCGY054147	FCC DoC Approved
3	MODEM	ACEEX	1414V/3	0401008269	IFAXDM1414

NO.	SIGNAL CABLE DESCRIPTION OF THE ABOVE SUPPORT UNITS
1	NA
2	1.2m shielded cable
3	1.2m shielded cable

**NOTE:** All power cords of the above support units are non-shielded (1.8m).

### 3.5 CONFIGURATION OF SYSTEM UNDER TEST

Test mode A

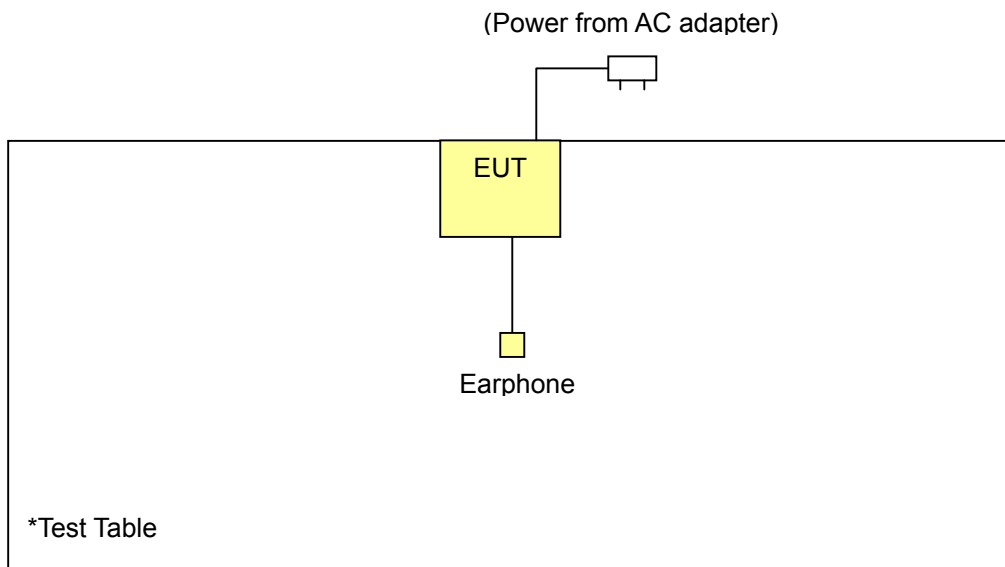



### Test mode B

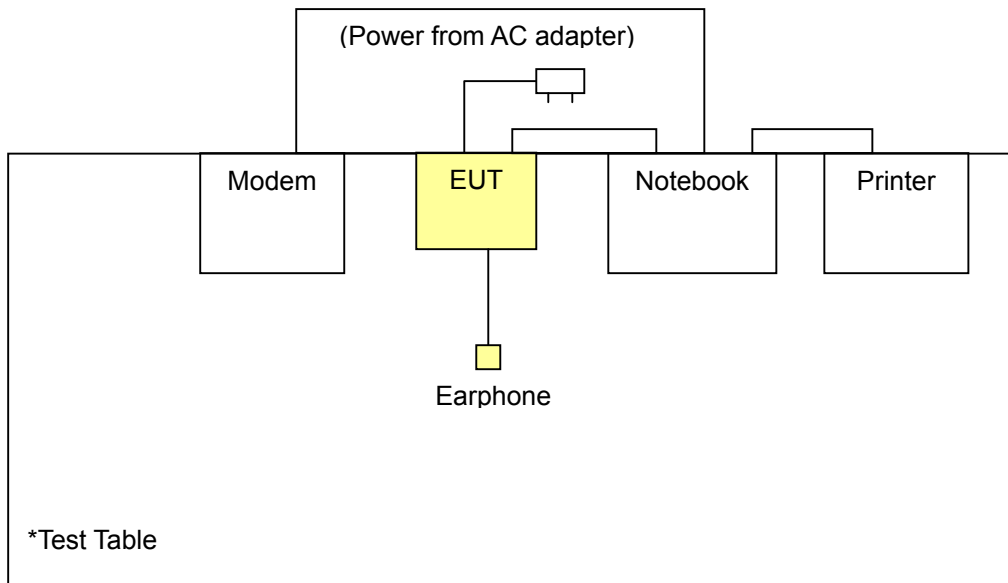

### Test mode C

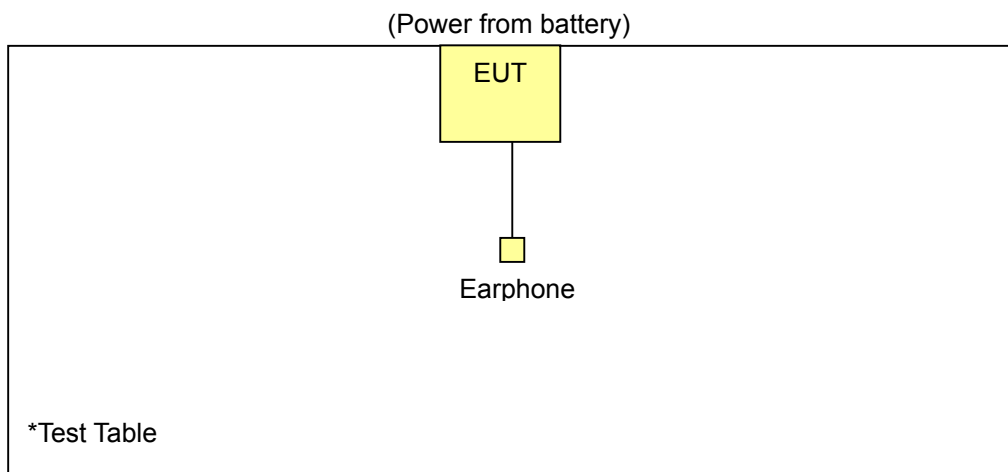



## 4 TEST TYPES AND RESULTS

### 4.1 CONDUCTED EMISSION MEASUREMENT

#### 4.1.1 LIMITS OF CONDUCTED EMISSION MEASUREMENT

FREQUENCY OF EMISSION (MHz)	CONDUCTED LIMIT (dB $\mu$ V)	
	Quasi-peak	Average
0.15-0.5	66 to 56	56 to 46
0.5-5	56	46
5-30	60	50

- NOTE:**
1. The lower limit shall apply at the transition frequencies.
  2. The limit decreases in line with the logarithm of the frequency in the range of 0.15 to 0.50 MHz.
  3. All emanations from a class A/B digital device or system, including any network of conductors and apparatus connected thereto, shall not exceed the level of field strengths specified above.

#### 4.1.2 TEST INSTRUMENTS

DESCRIPTION & MANUFACTURER	MODEL NO.	SERIAL NO.	CALIBRATED UNTIL
Test Receiver ROHDE & SCHWARZ	ESCS30	100288	Nov. 06, 2005
RF signal cable Woken	5D-FB	Cable-HyC02-01	Mar. 07, 2005
LISN ROHDE & SCHWARZ	ESH2-Z5	100100	Mar. 10, 2005
LISN ROHDE & SCHWARZ	ESH3-Z5	100311	Mar. 04, 2005
Software ADT	ADT_Cond_V3	NA	NA

- NOTE:**
1. The calibration interval of the above test instruments is 12 months and the calibrations are traceable to NML/ROC and NIST/USA.
  2. The test was performed in HwaYa Shielded Room 2.
  3. The VCCI Site Registration No. is C-2047.



#### **4.1.3 TEST PROCEDURES**

- a. The EUT was placed 0.4 meters from the conducting wall of the shielded room with EUT being connected to the power mains through a line impedance stabilization network (LISN). Other support units were connected to the power mains through another LISN. The two LISNs provide 50 ohm/ 50uH of coupling impedance for the measuring instrument.
- b. Both lines of the power mains connected to the EUT were checked for maximum conducted interference.
- c. The frequency range from 150 kHz to 30 MHz was searched. Emission levels (Limit -20dB) was not recorded.

#### **4.1.4 DEVIATION FROM TEST STANDARD**

No deviation.

#### 4.1.5 TEST SETUP

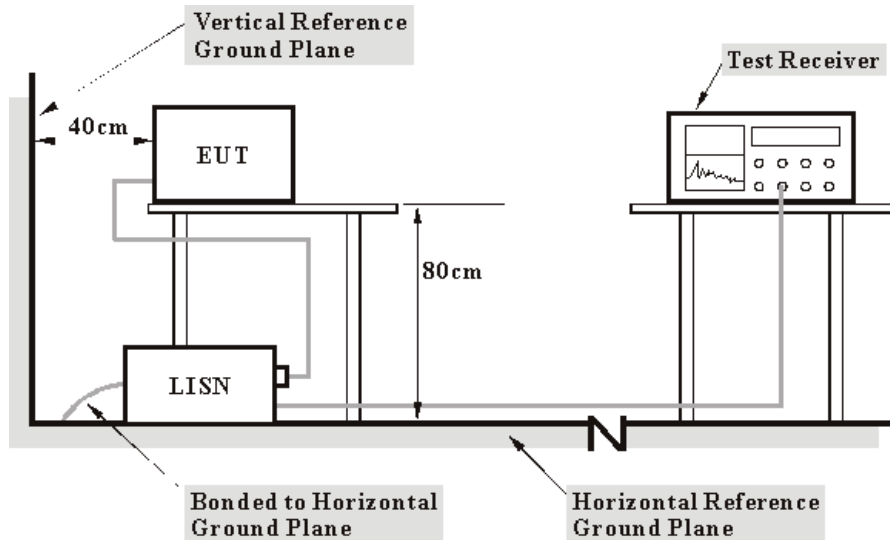

- Note: 1. Support units were connected to second LISN.  
 2. Both of LISNs (AMN) 80 cm from EUT and at the least 80 cm from other units and other metal planes support units.

For the actual test configuration, please refer to the related item – Photographs of the Test Configuration.

#### 4.1.6 EUT OPERATING CONDITIONS

Test mode A (Charger function)

- a. The EUT was powered by the power adapter.

Test mode B (Charger function)

- a. The EUT was powered by the power adapter. (Link mode)
- b. The EUT connected to the notebook.
- c. The EUT communicated data with the notebook.
- d. The notebook sent "H" messages to the modem.
- e. The notebook sent "H" messages to the printer and the printer printed them out.
- f. Step e~f were repeated.



**4.1.7 TEST RESULTS (A)**

<b>EUT</b>	PDT ( Portable Data Terminal )	<b>MODEL</b>	IT7000
<b>CHANNEL</b>	0	<b>6dB BANDWIDTH</b>	9 kHz
<b>INPUT POWER (SYSTEM)</b>	120 Vac, 60 Hz	<b>PHASE</b>	Line (L)
<b>ENVIRONMENTAL CONDITIONS</b>	25 deg. C, 65% RH, 991 hPa	<b>TESTED BY</b>	Rush Kao

No	Freq. [MHz]	Corr. Factor (dB)	Reading Value		Emission Level		Limit		Margin	
			[dB (uV)]		[dB (uV)]		[dB (uV)]		(dB)	
			Q.P.	AV.	Q.P.	AV.	Q.P.	AV.	Q.P.	AV.
1	0.166	0.10	48.26	-	48.36	-	65.18	55.18	-16.81	-
2	0.224	0.10	37.93	-	38.03	-	62.66	52.66	-24.63	-
3	0.279	0.11	35.66	-	35.77	-	60.85	50.85	-25.08	-
4	0.552	0.15	32.45	-	32.60	-	56.00	46.00	-23.40	-
5	0.720	0.18	32.65	-	32.83	-	56.00	46.00	-23.17	-
6	3.047	0.29	32.78	-	33.07	-	56.00	46.00	-22.93	-

- REMARKS:**
1. Q.P. and AV. are abbreviations of quasi-peak and average individually.
  2. "-": The Quasi-peak reading value also meets average limit and measurement with the average detector is unnecessary.
  3. The emission levels of other frequencies were very low against the limit.
  4. Margin value = Emission level - Limit value
  5. Correction factor = Insertion loss + Cable loss
  6. Emission Level = Correction Factor + Reading Value.

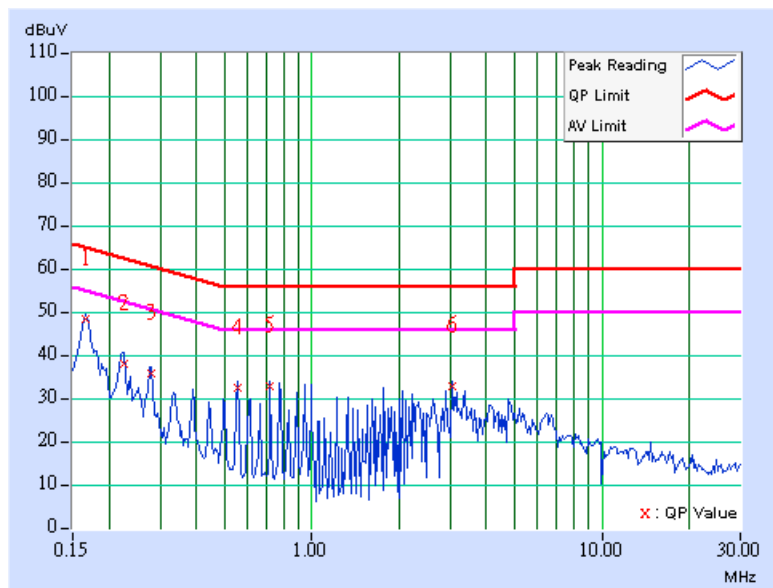



<b>EUT</b>	PDT ( Portable Data Terminal )	<b>MODEL</b>	IT7000
<b>CHANNEL</b>	0	<b>6dB BANDWIDTH</b>	9 kHz
<b>INPUT POWER (SYSTEM)</b>	120 Vac, 60 Hz	<b>PHASE</b>	Neutral (N)
<b>ENVIRONMENTAL CONDITIONS</b>	25 deg. C, 65% RH, 991 hPa	<b>TESTED BY</b>	Rush Kao

No	Freq. [MHz]	Corr. Factor (dB)	Reading Value		Emission Level		Limit		Margin	
			[dB (uV)]		[dB (uV)]		[dB (uV)]		(dB)	
			Q.P.	AV.	Q.P.	AV.	Q.P.	AV.	Q.P.	AV.
1	0.166	0.10	48.62	-	48.72	-	65.18	55.18	-16.46	-
2	0.224	0.10	38.08	-	38.18	-	62.66	52.66	-24.48	-
3	0.275	0.11	35.54	-	35.65	-	60.97	50.97	-25.32	-
4	0.720	0.17	31.92	-	32.09	-	56.00	46.00	-23.91	-
5	1.383	0.24	31.17	-	31.41	-	56.00	46.00	-24.59	-
6	3.270	0.28	32.18	-	32.46	-	56.00	46.00	-23.54	-

- REMARKS:**
1. Q.P. and AV. are abbreviations of quasi-peak and average individually.
  2. "-": The Quasi-peak reading value also meets average limit and measurement with the average detector is unnecessary.
  3. The emission levels of other frequencies were very low against the limit.
  4. Margin value = Emission level - Limit value
  5. Correction factor = Insertion loss + Cable loss
  6. Emission Level = Correction Factor + Reading Value.

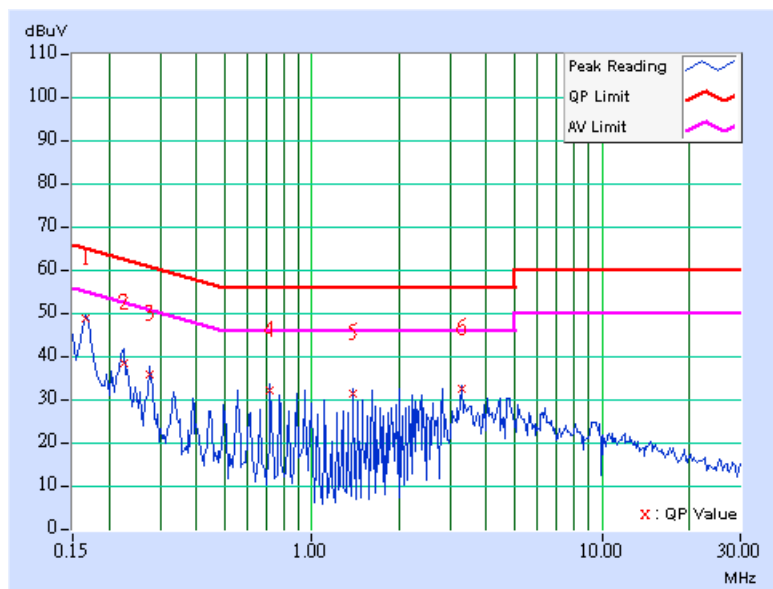





<b>EUT</b>	PDT ( Portable Data Terminal )	<b>MODEL</b>	IT7000
<b>CHANNEL</b>	39	<b>6dB BANDWIDTH</b>	9 kHz
<b>INPUT POWER (SYSTEM)</b>	120 Vac, 60 Hz	<b>PHASE</b>	Line (L)
<b>ENVIRONMENTAL CONDITIONS</b>	25 deg. C, 65% RH, 991 hPa	<b>TESTED BY</b>	Rush Kao

No	Freq. [MHz]	Corr. Factor (dB)	Reading Value [dB (uV)]		Emission Level [dB (uV)]		Limit [dB (uV)]		Margin (dB)	
			Q.P.	AV.	Q.P.	AV.	Q.P.	AV.	Q.P.	AV.
			1	0.166	0.10	47.98	-	48.08	-	65.18
2	0.220	0.10	38.48	-	38.58	-	62.81	52.81	-24.23	-
3	0.275	0.11	35.01	-	35.12	-	60.97	50.97	-25.85	-
4	0.552	0.15	32.06	-	32.21	-	56.00	46.00	-23.79	-
5	0.720	0.18	32.39	-	32.57	-	56.00	46.00	-23.43	-
6	1.164	0.25	32.78	-	33.03	-	56.00	46.00	-22.97	-

- REMARKS:**
1. Q.P. and AV. are abbreviations of quasi-peak and average individually.
  2. "-": The Quasi-peak reading value also meets average limit and measurement with the average detector is unnecessary.
  3. The emission levels of other frequencies were very low against the limit.
  4. Margin value = Emission level - Limit value
  5. Correction factor = Insertion loss + Cable loss
  6. Emission Level = Correction Factor + Reading Value.

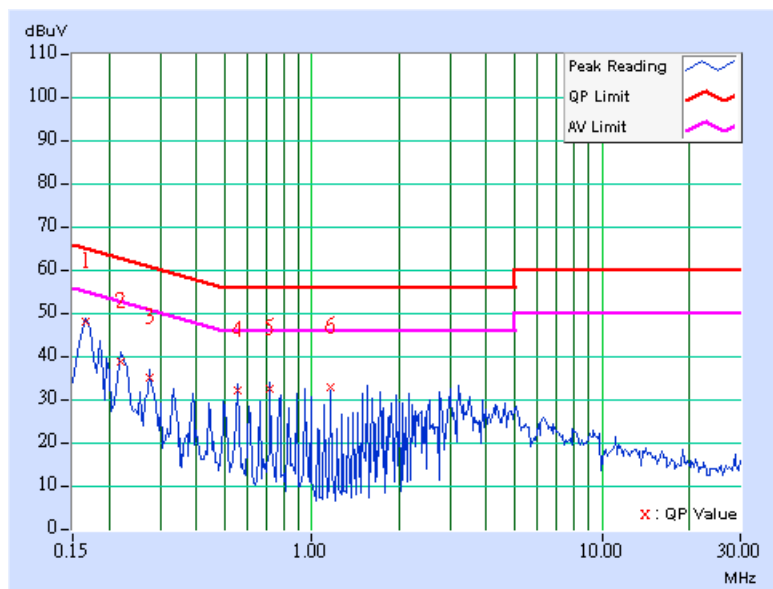



<b>EUT</b>	PDT ( Portable Data Terminal )	<b>MODEL</b>	IT7000
<b>CHANNEL</b>	39	<b>6dB BANDWIDTH</b>	9 kHz
<b>INPUT POWER (SYSTEM)</b>	120 Vac, 60 Hz	<b>PHASE</b>	Neutral (N)
<b>ENVIRONMENTAL CONDITIONS</b>	25 deg. C, 65% RH, 991 hPa	<b>TESTED BY</b>	Rush Kao

No	Freq. [MHz]	Corr. Factor (dB)	Reading Value [dB (uV)]		Emission Level [dB (uV)]		Limit [dB (uV)]		Margin (dB)	
			Q.P.	AV.	Q.P.	AV.	Q.P.	AV.	Q.P.	AV.
			1	0.166	0.10	48.58	-	48.68	-	65.18
2	0.220	0.10	39.01	-	39.11	-	62.81	52.81	-23.70	-
3	0.275	0.11	35.50	-	35.61	-	60.97	50.97	-25.36	-
4	0.552	0.15	31.59	-	31.74	-	56.00	46.00	-24.26	-
5	0.720	0.17	31.90	-	32.07	-	56.00	46.00	-23.93	-
6	1.551	0.25	32.25	-	32.50	-	56.00	46.00	-23.50	-

- REMARKS:**
1. Q.P. and AV. are abbreviations of quasi-peak and average individually.
  2. "-": The Quasi-peak reading value also meets average limit and measurement with the average detector is unnecessary.
  3. The emission levels of other frequencies were very low against the limit.
  4. Margin value = Emission level - Limit value
  5. Correction factor = Insertion loss + Cable loss
  6. Emission Level = Correction Factor + Reading Value.

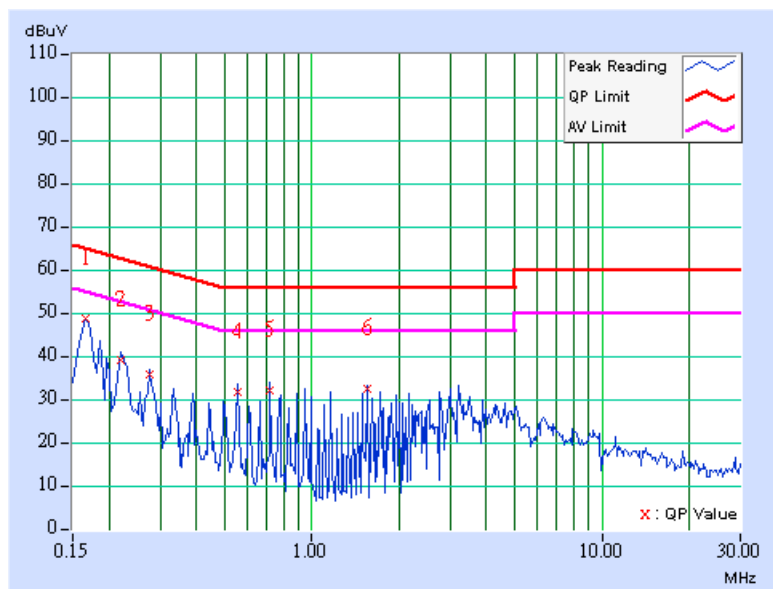



<b>EUT</b>	PDT ( Portable Data Terminal )	<b>MODEL</b>	IT7000
<b>CHANNEL</b>	78	<b>6dB BANDWIDTH</b>	9 kHz
<b>INPUT POWER (SYSTEM)</b>	120 Vac, 60 Hz	<b>PHASE</b>	Line (L)
<b>ENVIRONMENTAL CONDITIONS</b>	25 deg. C, 65% RH, 991 hPa	<b>TESTED BY</b>	Rush Kao

No	Freq. [MHz]	Corr. Factor (dB)	Reading Value		Emission Level		Limit		Margin	
			[dB (uV)]		[dB (uV)]		[dB (uV)]		(dB)	
			Q.P.	AV.	Q.P.	AV.	Q.P.	AV.	Q.P.	AV.
1	0.166	0.10	47.98	-	48.08	-	65.18	55.18	-17.09	-
2	0.224	0.10	37.51	-	37.61	-	62.66	52.66	-25.05	-
3	0.275	0.11	34.97	-	35.08	-	60.97	50.97	-25.89	-
4	0.720	0.18	32.41	-	32.59	-	56.00	46.00	-23.41	-
5	1.605	0.26	32.55	-	32.81	-	56.00	46.00	-23.19	-
6	2.824	0.28	30.82	-	31.10	-	56.00	46.00	-24.90	-

- REMARKS:**
1. Q.P. and AV. are abbreviations of quasi-peak and average individually.
  2. "-": The Quasi-peak reading value also meets average limit and measurement with the average detector is unnecessary.
  3. The emission levels of other frequencies were very low against the limit.
  4. Margin value = Emission level - Limit value
  5. Correction factor = Insertion loss + Cable loss
  6. Emission Level = Correction Factor + Reading Value.

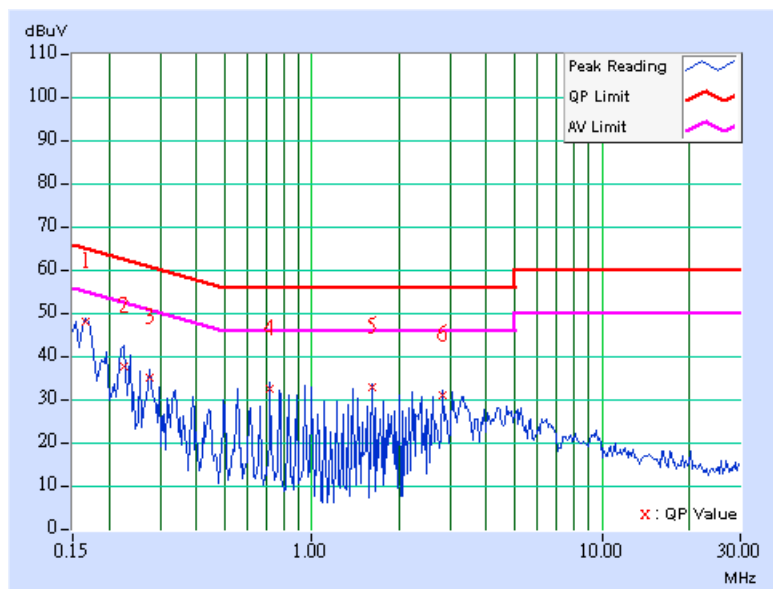



<b>EUT</b>	PDT ( Portable Data Terminal )	<b>MODEL</b>	IT7000
<b>CHANNEL</b>	78	<b>6dB BANDWIDTH</b>	9 kHz
<b>INPUT POWER (SYSTEM)</b>	120 Vac, 60 Hz	<b>PHASE</b>	Netural (N)
<b>ENVIRONMENTAL CONDITIONS</b>	25 deg. C, 65% RH, 991 hPa	<b>TESTED BY</b>	Rush Kao

No	Freq. [MHz]	Corr. Factor (dB)	Reading Value		Emission Level		Limit		Margin	
			[dB (uV)]		[dB (uV)]		[dB (uV)]		(dB)	
			Q.P.	AV.	Q.P.	AV.	Q.P.	AV.	Q.P.	AV.
1	0.166	0.10	48.44	-	48.54	-	65.18	55.18	-16.64	-
2	0.224	0.10	37.97	-	38.07	-	62.66	52.66	-24.59	-
3	0.279	0.11	35.72	-	35.83	-	60.85	50.85	-25.02	-
4	0.552	0.15	31.80	-	31.95	-	56.00	46.00	-24.05	-
5	0.720	0.17	31.88	-	32.05	-	56.00	46.00	-23.95	-
6	1.551	0.25	32.27	-	32.52	-	56.00	46.00	-23.48	-

- REMARKS:**
1. Q.P. and AV. are abbreviations of quasi-peak and average individually.
  2. "-": The Quasi-peak reading value also meets average limit and measurement with the average detector is unnecessary.
  3. The emission levels of other frequencies were very low against the limit.
  4. Margin value = Emission level - Limit value
  5. Correction factor = Insertion loss + Cable loss
  6. Emission Level = Correction Factor + Reading Value.

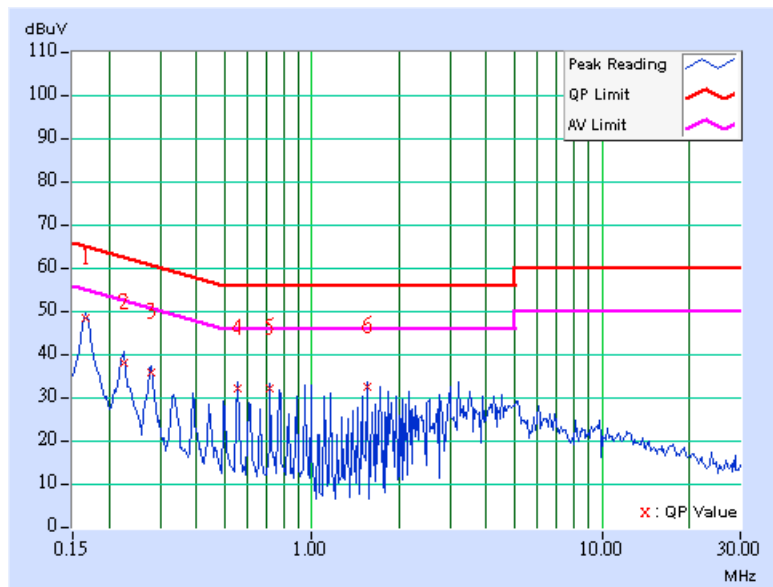



**4.1.8 TEST RESULTS (B)**

<b>EUT</b>	PDT ( Portable Data Terminal )	<b>MODEL</b>	IT7000
<b>CHANNEL</b>	0	<b>6dB BANDWIDTH</b>	9 kHz
<b>INPUT POWER (SYSTEM)</b>	120 Vac, 60 Hz	<b>PHASE</b>	Line (L)
<b>ENVIRONMENTAL CONDITIONS</b>	25 deg. C, 65% RH, 991 hPa	<b>TESTED BY</b>	Rush Kao

No	Freq. [MHz]	Corr. Factor (dB)	Reading Value [dB (uV)]		Emission Level [dB (uV)]		Limit [dB (uV)]		Margin (dB)	
			Q.P.	AV.	Q.P.	AV.	Q.P.	AV.	Q.P.	AV.
			1	0.166	0.10	46.63	-	46.73	-	65.18
2	0.220	0.10	37.49	-	37.59	-	62.81	52.81	-25.22	-
3	0.279	0.11	34.03	-	34.14	-	60.85	50.85	-26.71	-
4	0.552	0.15	32.83	-	32.98	-	56.00	46.00	-23.02	-
5	0.775	0.20	32.22	-	32.42	-	56.00	46.00	-23.58	-
6	1.164	0.25	32.90	-	33.15	-	56.00	46.00	-22.85	-

- REMARKS:**
1. Q.P. and AV. are abbreviations of quasi-peak and average individually.
  2. "-": The Quasi-peak reading value also meets average limit and measurement with the average detector is unnecessary.
  3. The emission levels of other frequencies were very low against the limit.
  4. Margin value = Emission level - Limit value
  5. Correction factor = Insertion loss + Cable loss
  6. Emission Level = Correction Factor + Reading Value.

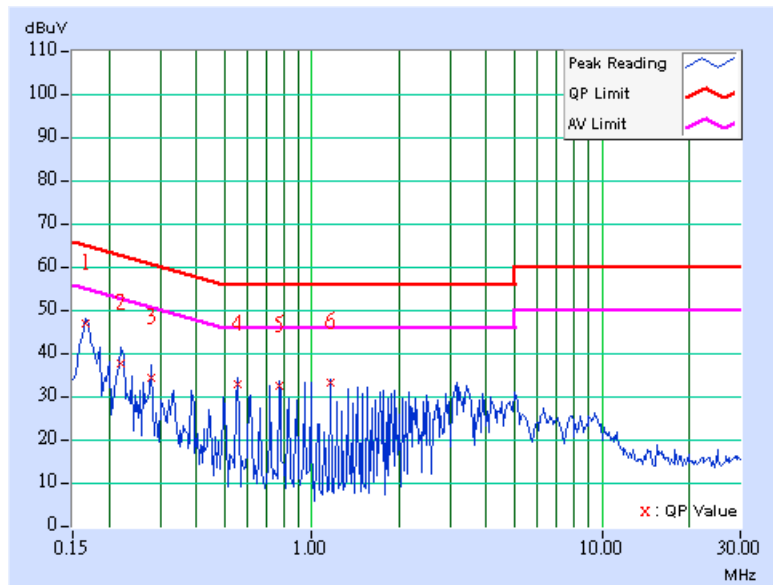



<b>EUT</b>	PDT ( Portable Data Terminal )	<b>MODEL</b>	IT7000
<b>CHANNEL</b>	0	<b>6dB BANDWIDTH</b>	9 kHz
<b>INPUT POWER (SYSTEM)</b>	120 Vac, 60 Hz	<b>PHASE</b>	Neutral (N)
<b>ENVIRONMENTAL CONDITIONS</b>	25 deg. C, 65% RH, 991 hPa	<b>TESTED BY</b>	Rush Kao

No	Freq. [MHz]	Corr. Factor (dB)	Reading Value		Emission Level		Limit		Margin	
			[dB (uV)]		[dB (uV)]		[dB (uV)]		(dB)	
			Q.P.	AV.	Q.P.	AV.	Q.P.	AV.	Q.P.	AV.
1	0.166	0.10	47.25	-	47.35	-	65.18	55.18	-17.83	-
2	0.232	0.10	23.98	-	24.08	-	62.38	52.38	-38.29	-
3	0.552	0.15	32.15	-	32.30	-	56.00	46.00	-23.70	-
4	0.775	0.19	31.66	-	31.85	-	56.00	46.00	-24.15	-
5	1.164	0.24	32.52	-	32.76	-	56.00	46.00	-23.24	-
6	1.328	0.24	31.57	-	31.81	-	56.00	46.00	-24.19	-

- REMARKS:**
1. Q.P. and AV. are abbreviations of quasi-peak and average individually.
  2. "-": The Quasi-peak reading value also meets average limit and measurement with the average detector is unnecessary.
  3. The emission levels of other frequencies were very low against the limit.
  4. Margin value = Emission level - Limit value
  5. Correction factor = Insertion loss + Cable loss
  6. Emission Level = Correction Factor + Reading Value.

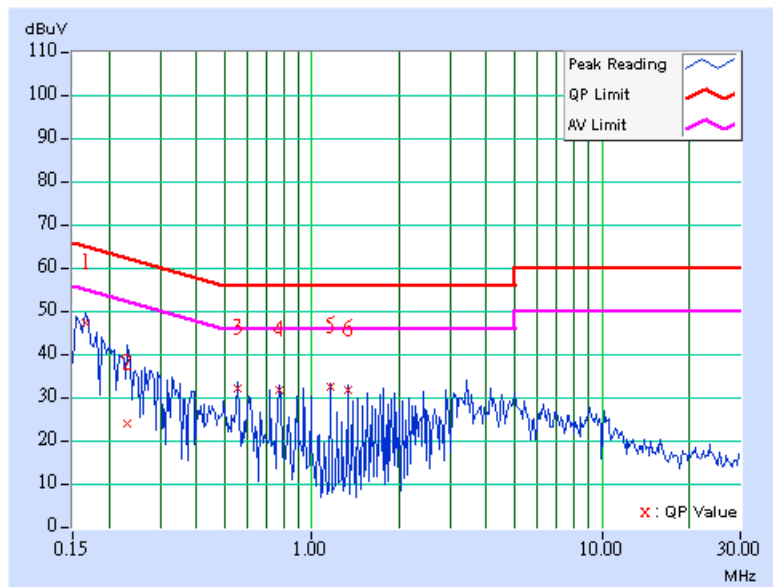



<b>EUT</b>	PDT ( Portable Data Terminal )	<b>MODEL</b>	IT7000
<b>CHANNEL</b>	39	<b>6dB BANDWIDTH</b>	9 kHz
<b>INPUT POWER (SYSTEM)</b>	120 Vac, 60 Hz	<b>PHASE</b>	Line (L)
<b>ENVIRONMENTAL CONDITIONS</b>	25 deg. C, 65% RH, 991 hPa	<b>TESTED BY</b>	Rush Kao

No	Freq. [MHz]	Corr. Factor (dB)	Reading Value		Emission Level		Limit		Margin	
			[dB (uV)]		[dB (uV)]		[dB (uV)]		(dB)	
			Q.P.	AV.	Q.P.	AV.	Q.P.	AV.	Q.P.	AV.
1	0.166	0.10	46.93	-	47.03	-	65.18	55.18	-18.14	-
2	0.220	0.10	37.67	-	37.77	-	62.81	52.81	-25.04	-
3	0.279	0.11	34.34	-	34.45	-	60.85	50.85	-26.40	-
4	0.775	0.20	32.02	-	32.22	-	56.00	46.00	-23.78	-
5	1.551	0.26	32.42	-	32.68	-	56.00	46.00	-23.32	-
6	3.211	0.29	33.08	-	33.37	-	56.00	46.00	-22.63	-

- REMARKS:**
1. Q.P. and AV. are abbreviations of quasi-peak and average individually.
  2. "-": The Quasi-peak reading value also meets average limit and measurement with the average detector is unnecessary.
  3. The emission levels of other frequencies were very low against the limit.
  4. Margin value = Emission level - Limit value
  5. Correction factor = Insertion loss + Cable loss
  6. Emission Level = Correction Factor + Reading Value.

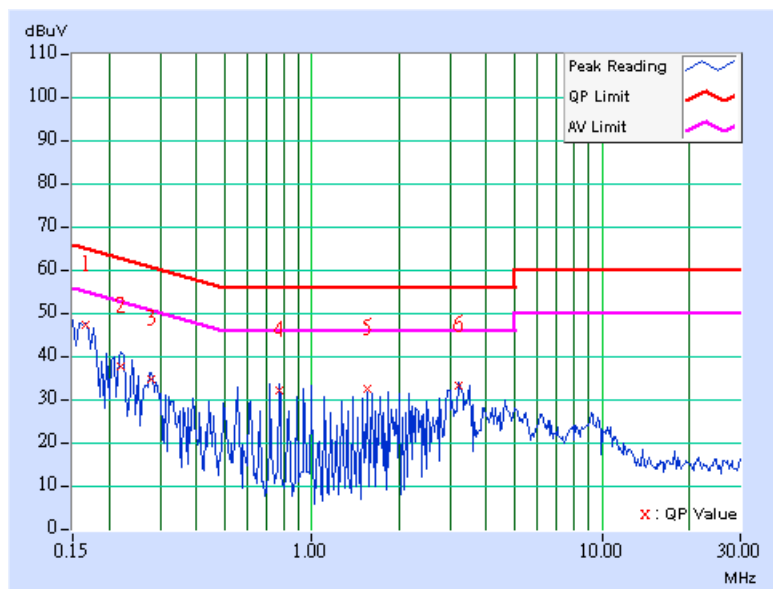



<b>EUT</b>	PDT ( Portable Data Terminal )	<b>MODEL</b>	IT7000
<b>CHANNEL</b>	39	<b>6dB BANDWIDTH</b>	9 kHz
<b>INPUT POWER (SYSTEM)</b>	120 Vac, 60 Hz	<b>PHASE</b>	Neutral (N)
<b>ENVIRONMENTAL CONDITIONS</b>	25 deg. C, 65% RH, 991 hPa	<b>TESTED BY</b>	Rush Kao

No	Freq. [MHz]	Corr. Factor (dB)	Reading Value [dB (uV)]		Emission Level [dB (uV)]		Limit [dB (uV)]		Margin (dB)	
			Q.P.	AV.	Q.P.	AV.	Q.P.	AV.	Q.P.	AV.
			1	0.166	0.10	47.41	-	47.51	-	65.18
2	0.224	0.10	36.86	-	36.96	-	62.66	52.66	-25.70	-
3	0.275	0.11	34.66	-	34.77	-	60.97	50.97	-26.20	-
4	0.552	0.15	32.22	-	32.37	-	56.00	46.00	-23.63	-
5	0.720	0.17	31.65	-	31.82	-	56.00	46.00	-24.18	-
6	1.383	0.24	32.89	-	33.13	-	56.00	46.00	-22.87	-

- REMARKS:**
1. Q.P. and AV. are abbreviations of quasi-peak and average individually.
  2. "-": The Quasi-peak reading value also meets average limit and measurement with the average detector is unnecessary.
  3. The emission levels of other frequencies were very low against the limit.
  4. Margin value = Emission level - Limit value
  5. Correction factor = Insertion loss + Cable loss
  6. Emission Level = Correction Factor + Reading Value.

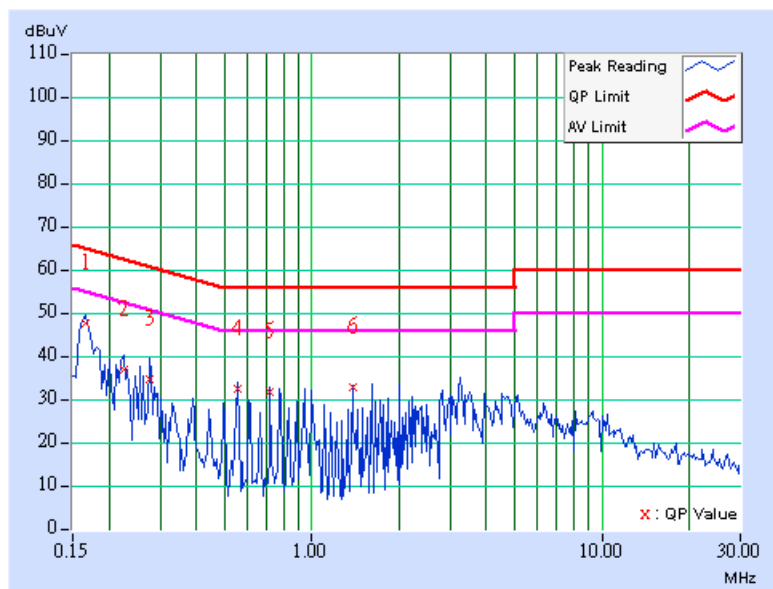





<b>EUT</b>	PDT ( Portable Data Terminal )	<b>MODEL</b>	IT7000
<b>CHANNEL</b>	78	<b>6dB BANDWIDTH</b>	9 kHz
<b>INPUT POWER (SYSTEM)</b>	120 Vac, 60 Hz	<b>PHASE</b>	Line (L)
<b>ENVIRONMENTAL CONDITIONS</b>	25 deg. C, 65% RH, 991 hPa	<b>TESTED BY</b>	Rush Kao

No	Freq. [MHz]	Corr. Factor (dB)	Reading Value		Emission Level		Limit		Margin	
			[dB (uV)]		[dB (uV)]		[dB (uV)]		(dB)	
			Q.P.	AV.	Q.P.	AV.	Q.P.	AV.	Q.P.	AV.
1	0.166	0.10	47.09	-	47.19	-	65.18	55.18	-17.98	-
2	0.275	0.11	34.34	-	34.45	-	60.97	50.97	-26.52	-
3	0.556	0.15	31.55	-	31.70	-	56.00	46.00	-24.30	-
4	0.775	0.20	31.88	-	32.08	-	56.00	46.00	-23.92	-
5	1.551	0.26	32.42	-	32.68	-	56.00	46.00	-23.32	-
6	3.215	0.29	32.28	-	32.57	-	56.00	46.00	-23.43	-

- REMARKS:**
1. Q.P. and AV. are abbreviations of quasi-peak and average individually.
  2. "-": The Quasi-peak reading value also meets average limit and measurement with the average detector is unnecessary.
  3. The emission levels of other frequencies were very low against the limit.
  4. Margin value = Emission level - Limit value
  5. Correction factor = Insertion loss + Cable loss
  6. Emission Level = Correction Factor + Reading Value.

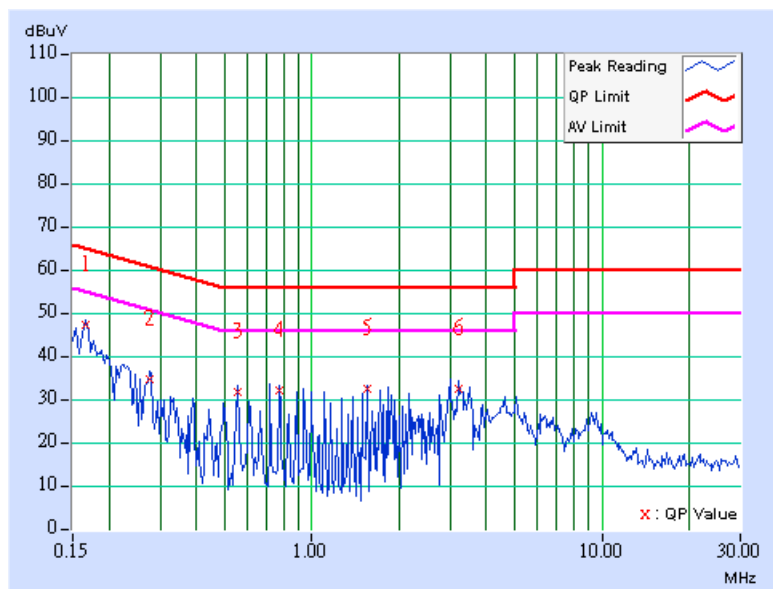



<b>EUT</b>	PDT ( Portable Data Terminal )	<b>MODEL</b>	IT7000
<b>CHANNEL</b>	78	<b>6dB BANDWIDTH</b>	9 kHz
<b>INPUT POWER (SYSTEM)</b>	120 Vac, 60 Hz	<b>PHASE</b>	Netural (N)
<b>ENVIRONMENTAL CONDITIONS</b>	25 deg. C, 65% RH, 991 hPa	<b>TESTED BY</b>	Rush Kao

No	Freq. [MHz]	Corr. Factor (dB)	Reading Value		Emission Level		Limit		Margin	
			[dB (uV)]		[dB (uV)]		[dB (uV)]		(dB)	
			Q.P.	AV.	Q.P.	AV.	Q.P.	AV.	Q.P.	AV.
1	0.166	0.10	47.84	-	47.94	-	65.18	55.18	-17.24	-
2	0.220	0.10	38.42	-	38.52	-	62.81	52.81	-24.29	-
3	0.279	0.11	35.17	-	35.28	-	60.85	50.85	-25.57	-
4	0.552	0.15	31.98	-	32.13	-	56.00	46.00	-23.87	-
5	3.211	0.28	33.10	-	33.38	-	56.00	46.00	-22.62	-
6	4.984	0.35	30.09	-	30.44	-	56.00	46.00	-25.56	-

- REMARKS:**
1. Q.P. and AV. are abbreviations of quasi-peak and average individually.
  2. "-": The Quasi-peak reading value also meets average limit and measurement with the average detector is unnecessary.
  3. The emission levels of other frequencies were very low against the limit.
  4. Margin value = Emission level - Limit value
  5. Correction factor = Insertion loss + Cable loss
  6. Emission Level = Correction Factor + Reading Value.

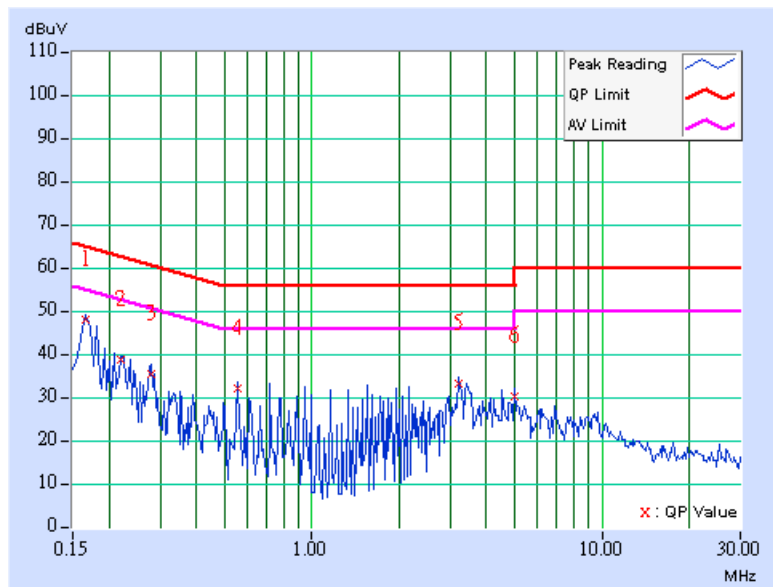



## 4.2 RADIATED EMISSION MEASUREMENT

### 4.2.1 LIMITS OF RADIATED EMISSION MEASUREMENT

Emissions radiated outside of the specified bands, shall be according to the general radiated limits in 15.209 as the following:

Frequencies (MHz)	Field strength (microvolts/meter)	Measurement distance (meters)
0.009-0.490	2400/F(kHz)	300
0.490-1.705	24000/F(kHz)	30
1.705-30.0	30	30
30-88	100	3
88-216	150	3
216-960	200	3
Above 960	500	3

As shown in 15.35(b), for frequencies above 1000MHz, the field strength limits are based on average detector, however, the peak field strength of any emission shall not exceed the maximum permitted average limits, specified above by more than 20dB under any condition of modulation.



#### 4.2.2 TEST INSTRUMENTS

DESCRIPTION & MANUFACTURER	MODEL NO.	SERIAL NO.	CALIBRATED UNTIL
Test Receiver ROHDE & SCHWARZ	ESI7	838496/016	Feb. 09, 2005
Spectrum Analyzer ROHDE & SCHWARZ	FSP40	100041	Nov. 29, 2005
BILOG Antenna SCHWARZBECK	VULB9168	9168-155	Feb. 03, 2005
HORN Antenna SCHWARZBECK	BBHA 9120D	9120D-404	Feb. 03, 2005
HORN Antenna SCHWARZBECK	BBHA 9170	BBHA 9170242	Feb. 23, 2005
Preamplifier Agilent	8447D	2944A10631	Nov. 17, 2005
Preamplifier Agilent	8449B	3008A01960	Nov. 14, 2005
RF signal cable HUBER+SUHNNER	SUCOFLEX 104	219272/4	Mar. 04, 2005
RF signal cable HUBER+SUHNNER	SUCOFLEX 104	219275/4	Mar. 04, 2005
Software ADT.	ADT_Radiated_V5.14	NA	NA
Antenna Tower inn-co GmbH	MA 4000	010303	NA
Antenna Tower Controller inn-co GmbH	CO2000	019303	NA
Turn Table ADT.	TT100.	TT93021704	NA
Turn Table Controller ADT.	SC100.	SC93021704	NA

- NOTE:**
1. The calibration interval of the above test instruments is 12 months and the calibrations are traceable to NML/ROC and NIST/USA.
  2. The test was performed in HwaYa Chamber 3.
  3. The horn antenna and HP preamplifier (model: 8449B) are used only for the measurement of emission frequency above 1GHz if tested.
  4. The IC Site Registration No. is IC4924-4.



#### 4.2.3 TEST PROCEDURE

- a. The EUT was placed on the top of a rotating table 0.8 meters above the ground at a 3 meters semi-anechoic chamber. The table was rotated 360 degrees to determine the position of the highest radiation.
- b. The EUT was set 3 meters away from the interference-receiving antenna, which was mounted on the top of a variable-height antenna tower.
- c. The antenna is a broadband antenna, and its height is varied from one meter to four meters above the ground to determine the maximum value of the field strength. Both horizontal and vertical polarizations of the antenna are set to make the measurement.
- d. For each suspected emission, the EUT was arranged to its worst case and then the antenna was tuned to heights from 1 meter to 4 meters and the rotatable table was turned from 0 degrees to 360 degrees to find the maximum reading.
- e. The test-receiver system was set to Peak Detect Function and Specified Bandwidth with Maximum Hold Mode.
- f. If the emission level of the EUT in peak mode was 10 dB lower than the limit specified, then testing could be stopped and the peak values of the EUT would be reported. Otherwise the emissions that did not have 10 dB margin would be re-tested one by one using peak, quasi-peak or average method as specified and then reported in a data sheet.

#### NOTE:

1. The resolution bandwidth and video bandwidth of test receiver/spectrum analyzer is 120kHz for Quasi-peak detection (QP) at frequency below 1GHz.
2. The resolution bandwidth and video bandwidth of test receiver/spectrum analyzer is 1 MHz for Peak detection at frequency above 1GHz.

#### 4.2.4 DEVIATION FROM TEST STANDARD

No deviation.

#### 4.2.5 TEST SETUP

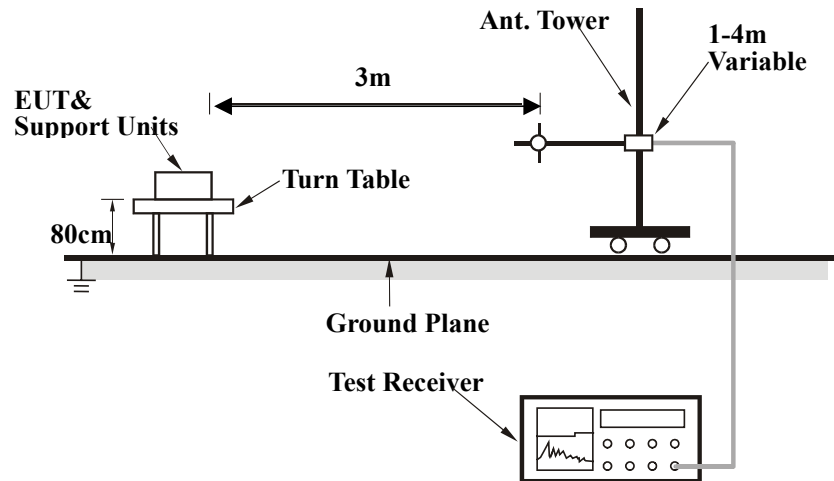

For the actual test configuration, please refer to the related Item – Photographs of the Test Configuration.

#### 4.2.6 EUT OPERATING CONDITIONS

##### Test mode A

- a. The EUT was powered by the power adapter.
- b. The EUT was set under transmitting continuously condition.

##### Test mode B

- a. The EUT was powered by the power adapter.
- b. The EUT connected to the notebook.
- c. The EUT communicated data with the notebook.
- d. The EUT was set under transmitting continuously condition.
- e. The notebook sent “H” messages to the modem.
- f. The notebook sent “H” messages to the printer and the printer printed them out.
- g. Step e~f were repeated.

##### Test mode C

- a. The EUT was powered by the battery.
- b. The EUT was set under transmitting continuously condition.



#### 4.2.7 TEST RESULTS (A)

<b>EUT</b>	PDT ( Portable Data Terminal )	<b>MODEL</b>	IT7000
<b>CHANNEL</b>	0	<b>FREQUENCY RANGE</b>	Below 1000MHz
<b>INPUT POWER (SYSTEM)</b>	120 Vac, 60 Hz	<b>DETECTOR FUNCTION</b>	Quasi-Peak
<b>ENVIRONMENTAL CONDITIONS</b>	21 deg. C, 61% RH, 991 hPa	<b>TESTED BY</b>	Brad Wu

#### ANTENNA POLARITY & TEST DISTANCE: HORIZONTAL AT 3 M

No.	Freq. (MHz)	Emission Level (dBuV/m)	Limit (dBuV/m)	Margin (dB)	Antenna Height (m)	Table Angle (Degree)	Raw Value (dBuV)	Correction Factor (dB/m)
1	307.98	34.66 QP	46.00	-11.34	1.00 H	169	19.69	14.98
2	352.69	31.41 QP	46.00	-14.59	1.00 H	139	15.49	15.92
3	572.34	38.47 QP	46.00	-7.53	1.00 H	79	18.02	20.45
4	659.82	33.74 QP	46.00	-12.26	1.00 H	283	11.69	22.05
5	704.53	34.85 QP	46.00	-11.15	1.50 H	61	12.24	22.62
6	924.19	30.19 QP	46.00	-15.81	1.00 H	280	4.66	25.52

- REMARKS:**
1. Emission level(dBuV/m)=Raw Value(dBuV) + Correction Factor(dB/m)
  2. Correction Factor(dB/m) = Antenna Factor (dB/m) + Cable Factor (dB)
  3. The other emission levels were very low against the limit.
  4. Margin value = Emission level – Limit value.



<b>EUT</b>	PDT ( Portable Data Terminal )	<b>MODEL</b>	IT7000
<b>CHANNEL</b>	0	<b>FREQUENCY RANGE</b>	Below 1000MHz
<b>INPUT POWER (SYSTEM)</b>	120 Vac, 60 Hz	<b>DETECTOR FUNCTION</b>	Quasi-Peak
<b>ENVIRONMENTAL CONDITIONS</b>	21 deg. C, 61% RH, 991 hPa	<b>TESTED BY</b>	Brad Wu

**ANTENNA POLARITY & TEST DISTANCE: VERTICAL AT 3 M**

No.	Freq. (MHz)	Emission Level (dBuV/m)	Limit (dBuV/m)	Margin (dB)	Antenna Height (m)	Table Angle (Degree)	Raw Value (dBuV)	Correction Factor (dB/m)
1	307.98	33.64 QP	46.00	-12.36	1.50 V	262	18.67	14.98
2	352.69	34.54 QP	46.00	-11.46	1.50 V	277	18.63	15.92
3	572.34	33.41 QP	46.00	-12.59	1.50 V	175	12.96	20.45
4	659.82	29.35 QP	46.00	-16.65	1.50 V	232	7.30	22.05
5	704.53	33.42 QP	46.00	-12.58	1.00 V	145	10.80	22.62
6	924.19	34.48 QP	46.00	-11.52	1.00 V	172	8.96	25.52

- REMARKS:**
1. Emission level(dBuV/m)=Raw Value(dBuV) + Correction Factor(dB/m)
  2. Correction Factor(dB/m) = Antenna Factor (dB/m) + Cable Factor (dB)
  3. The other emission levels were very low against the limit.
  4. Margin value = Emission level – Limit value.





#### 4.2.8 TEST RESULTS (B)

<b>EUT</b>	PDT ( Portable Data Terminal )	<b>MODEL</b>	IT7000
<b>CHANNEL</b>	0	<b>FREQUENCY RANGE</b>	Below 1000MHz
<b>INPUT POWER (SYSTEM)</b>	120 Vac, 60 Hz	<b>DETECTOR FUNCTION</b>	Quasi-Peak
<b>ENVIRONMENTAL CONDITIONS</b>	21 deg. C, 61% RH, 991 hPa	<b>TESTED BY</b>	Brad Wu

#### ANTENNA POLARITY & TEST DISTANCE: HORIZONTAL AT 3 M

No.	Freq. (MHz)	Emission Level (dBuV/m)	Limit (dBuV/m)	Margin (dB)	Antenna Height (m)	Table Angle (Degree)	Raw Value (dBuV)	Correction Factor (dB/m)
1	199.12	28.25 QP	43.50	-15.25	1.00 H	148	16.72	11.53
2	307.98	33.50 QP	46.00	-12.50	1.00 H	142	18.52	14.98
3	352.69	32.97 QP	46.00	-13.03	1.00 H	121	17.05	15.92
4	572.34	36.87 QP	46.00	-9.13	1.00 H	52	16.42	20.45
5	659.82	35.37 QP	46.00	-10.63	1.00 H	214	13.32	22.05
6	704.53	35.49 QP	46.00	-10.51	1.00 H	220	12.88	22.62

- REMARKS:**
1. Emission level(dBuV/m)=Raw Value(dBuV) + Correction Factor(dB/m)
  2. Correction Factor(dB/m) = Antenna Factor (dB/m) + Cable Factor (dB)
  3. The other emission levels were very low against the limit.
  4. Margin value = Emission level – Limit value.



<b>EUT</b>	PDT ( Portable Data Terminal )	<b>MODEL</b>	IT7000
<b>CHANNEL</b>	0	<b>FREQUENCY RANGE</b>	Below 1000MHz
<b>INPUT POWER (SYSTEM)</b>	120 Vac, 60 Hz	<b>DETECTOR FUNCTION</b>	Quasi-Peak
<b>ENVIRONMENTAL CONDITIONS</b>	21 deg. C, 61% RH, 991 hPa	<b>TESTED BY</b>	Brad Wu

#### ANTENNA POLARITY & TEST DISTANCE: VERTICAL AT 3 M

No.	Freq. (MHz)	Emission Level (dBuV/m)	Limit (dBuV/m)	Margin (dB)	Antenna Height (m)	Table Angle (Degree)	Raw Value (dBuV)	Correction Factor (dB/m)
1	307.98	34.01 QP	46.00	-11.99	1.50 V	130	19.04	14.98
2	352.69	30.30 QP	46.00	-15.70	1.50 V	148	14.38	15.92
3	572.34	33.64 QP	46.00	-12.36	1.50 V	202	13.18	20.45
4	659.82	30.61 QP	46.00	-15.39	1.00 V	148	8.56	22.05
5	704.53	33.20 QP	46.00	-12.80	1.00 V	124	10.58	22.62
6	881.42	39.92 QP	46.00	-6.08	1.00 V	97	15.05	24.87

- REMARKS:**
1. Emission level(dBuV/m)=Raw Value(dBuV) + Correction Factor(dB/m)
  2. Correction Factor(dB/m) = Antenna Factor (dB/m) + Cable Factor (dB)
  3. The other emission levels were very low against the limit.
  4. Margin value = Emission level – Limit value.



#### 4.2.9 TEST RESULTS (C)

<b>EUT</b>	PDT ( Portable Data Terminal )	<b>MODEL</b>	IT7000
<b>CHANNEL</b>	0	<b>FREQUENCY RANGE</b>	Below 1000MHz
<b>INPUT POWER (SYSTEM)</b>	120 Vac, 60 Hz	<b>DETECTOR FUNCTION</b>	Quasi-Peak
<b>ENVIRONMENTAL CONDITIONS</b>	24 deg. C, 64% RH, 991 hPa	<b>TESTED BY</b>	Rush Kao

#### ANTENNA POLARITY & TEST DISTANCE: HORIZONTAL AT 3 M

No.	Freq. (MHz)	Emission Level (dBuV/m)	Limit (dBuV/m)	Margin (dB)	Antenna Height (m)	Table Angle (Degree)	Raw Value (dBuV)	Correction Factor (dB/m)
1	307.98	31.97 QP	46.00	-14.03	1.00 H	271	17.38	14.59
2	352.69	32.10 QP	46.00	-13.90	1.00 H	103	16.51	15.58
3	527.64	30.91 QP	46.00	-15.09	1.25 H	97	11.85	19.06
4	572.34	39.13 QP	46.00	-6.87	1.25 H	286	19.06	20.07
5	659.82	36.94 QP	46.00	-9.06	1.00 H	277	15.37	21.58
<b>6</b>	<b>908.64</b>	<b>40.04 QP</b>	<b>46.00</b>	<b>-5.96</b>	<b>1.00 H</b>	<b>64</b>	<b>15.14</b>	<b>24.90</b>

- REMARKS:**
1. Emission level(dBuV/m)=Raw Value(dBuV) + Correction Factor(dB/m)
  2. Correction Factor(dB/m) = Antenna Factor (dB/m) + Cable Factor (dB)
  3. The other emission levels were very low against the limit.
  4. Margin value = Emission level – Limit value.



<b>EUT</b>	PDT ( Portable Data Terminal )	<b>MODEL</b>	IT7000
<b>CHANNEL</b>	0	<b>FREQUENCY RANGE</b>	Below 1000MHz
<b>INPUT POWER (SYSTEM)</b>	120 Vac, 60 Hz	<b>DETECTOR FUNCTION</b>	Quasi-Peak
<b>ENVIRONMENTAL CONDITIONS</b>	24 deg. C, 64% RH, 991 hPa	<b>TESTED BY</b>	Rush Kao

<b>ANTENNA POLARITY &amp; TEST DISTANCE: VERTICAL AT 3 M</b>								
No.	Freq. (MHz)	Emission Level (dBuV/m)	Limit (dBuV/m)	Margin (dB)	Antenna Height (m)	Table Angle (Degree)	Raw Value (dBuV)	Correction Factor (dB/m)
1	156.35	26.80 QP	43.50	-16.70	1.00 V	28	11.95	14.85
2	352.69	29.96 QP	46.00	-16.04	1.25 V	289	14.38	15.58
3	572.34	36.18 QP	46.00	-9.82	1.50 V	187	16.11	20.07
4	659.82	34.95 QP	46.00	-11.05	1.25 V	184	13.38	21.58
5	704.53	30.49 QP	46.00	-15.51	1.25 V	202	8.37	22.12
6	924.19	34.16 QP	46.00	-11.84	1.00 V	187	9.10	25.06

- REMARKS:**
1. Emission level(dBuV/m)=Raw Value(dBuV) + Correction Factor(dB/m)
  2. Correction Factor(dB/m) = Antenna Factor (dB/m) + Cable Factor (dB)
  3. The other emission levels were very low against the limit.
  4. Margin value = Emission level – Limit value.



**4.2.10 TEST RESULTS**

<b>EUT</b>	PDT ( Portable Data Terminal )	<b>MODEL</b>	IT7000
<b>CHANNEL</b>	0	<b>FREQUENCY RANGE</b>	1 ~25GHz
<b>INPUT POWER (SYSTEM)</b>	120 Vac, 60 Hz	<b>DETECTOR FUNCTION</b>	Peak (PK) Average (AV)
<b>ENVIRONMENTAL CONDITIONS</b>	25 deg. C, 59% RH, 991 hPa	<b>TESTED BY</b>	Rush Kao

<b>ANTENNA POLARITY &amp; TEST DISTANCE: HORIZONTAL AT 3 M</b>								
No.	Freq. (MHz)	Emission Level (dBuV/m)	Limit (dBuV/m)	Margin (dB)	Antenna Height (m)	Table Angle (Degree)	Raw Value (dBuV)	Correction Factor (dB/m)
1	*2402.00	90.53 PK			1.11 H	302	59.37	31.16
1	*2402.00	60.53 AV			1.11 H	302	29.37	31.16
2	4804.00	49.99 PK	74.00	-24.01	1.05 H	70	12.16	37.83
2	4804.00	19.99 AV	54.00	-34.01	1.05 H	70	-17.84	37.83

<b>ANTENNA POLARITY &amp; TEST DISTANCE: VERTICAL AT 3 M</b>								
No.	Freq. (MHz)	Emission Level (dBuV/m)	Limit (dBuV/m)	Margin (dB)	Antenna Height (m)	Table Angle (Degree)	Raw Value (dBuV)	Correction Factor (dB/m)
1	*2402.00	91.46 PK			1.39 V	226	60.30	31.16
1	*2402.00	61.46 AV			1.39 V	226	30.30	31.16
2	4804.00	50.54 PK	74.00	-23.46	1.18 V	190	12.71	37.83
2	4804.00	20.54 AV	54.00	-33.46	1.18 V	190	-17.29	37.83

- REMARKS:**
1. Emission level(dBuV/m)=Raw Value(dBuV) + Correction Factor(dB/m)
  2. Correction Factor(dB/m) = Antenna Factor (dB/m) + Cable Factor (dB)
  3. The other emission levels were very low against the limit.
  4. Margin value = Emission level – Limit value.
  5. “ \* ” : Fundamental frequency
  6. The DH5 packet was the worse case duty cycle for a transmit dwell time on a channel, based upon bluetooth theory the transmitter is on 0.625\*5 per 247 ms per channel. Therefore, the duty cycle be equal to:  $20\log(3.125/100) = -30\text{dB}$
  7. Average value = peak reading  $-20\log(\text{duty cycle})$



<b>EUT</b>	PDT ( Portable Data Terminal )	<b>MODEL</b>	IT7000
<b>CHANNEL</b>	39	<b>FREQUENCY RANGE</b>	1 ~25GHz
<b>INPUT POWER (SYSTEM)</b>	120 Vac, 60 Hz	<b>DETECTOR FUNCTION</b>	Peak (PK) Average (AV)
<b>ENVIRONMENTAL CONDITIONS</b>	25 deg. C, 59% RH, 991 hPa	<b>TESTED BY</b>	Rush Kao

<b>ANTENNA POLARITY &amp; TEST DISTANCE: HORIZONTAL AT 3 M</b>								
No.	Freq. (MHz)	Emission Level (dBuV/m)	Limit (dBuV/m)	Margin (dB)	Antenna Height (m)	Table Angle (Degree)	Raw Value (dBuV)	Correction Factor (dB/m)
1	*2441.00	86.79 PK			1.08 H	308	55.44	31.36
1	*2441.00	56.79 AV			1.08 H	308	25.43	31.36
2	4882.00	50.01 PK	74.00	-23.99	1.07 H	42	12.00	38.01
2	4882.00	20.01 AV	54.00	-33.99	1.07 H	42	-18.00	38.01

<b>ANTENNA POLARITY &amp; TEST DISTANCE: VERTICAL AT 3 M</b>								
No.	Freq. (MHz)	Emission Level (dBuV/m)	Limit (dBuV/m)	Margin (dB)	Antenna Height (m)	Table Angle (Degree)	Raw Value (dBuV)	Correction Factor (dB/m)
1	*2441.00	86.31 PK			1.14 V	192	54.95	31.36
1	*2441.00	56.31 AV			1.14 V	192	24.95	31.36
2	4882.00	49.84 PK	74.00	-24.16	1.23 V	224	11.83	38.01
2	4882.00	19.84 AV	54.00	-34.16	1.23 V	224	-18.17	38.01

- REMARKS:**
1. Emission level(dBuV/m)=Raw Value(dBuV) + Correction Factor(dB/m)
  2. Correction Factor(dB/m) = Antenna Factor (dB/m) + Cable Factor (dB)
  3. The other emission levels were very low against the limit.
  4. Margin value = Emission level – Limit value.
  5. “ \* “ : Fundamental frequency
  6. The DH5 packet was the worse case duty cycle for a transmit dwell time on a channel, based upon bluetooth theory the transmitter is on 0.625\*5 per 247 ms per channel. Therefore, the duty cycle be equal to:  $20\log(3.125/100) = -30\text{dB}$
  7. Average value = peak reading  $-20\log(\text{duty cycle})$



<b>EUT</b>	PDT ( Portable Data Terminal )	<b>MODEL</b>	IT7000
<b>CHANNEL</b>	78	<b>FREQUENCY RANGE</b>	1 ~25GHz
<b>INPUT POWER (SYSTEM)</b>	120 Vac, 60 Hz	<b>DETECTOR FUNCTION</b>	Peak (PK) Average (AV)
<b>ENVIRONMENTAL CONDITIONS</b>	25 deg. C, 59% RH, 991 hPa	<b>TESTED BY</b>	Rush Kao

<b>ANTENNA POLARITY &amp; TEST DISTANCE: HORIZONTAL AT 3 M</b>								
No.	Freq. (MHz)	Emission Level (dBuV/m)	Limit (dBuV/m)	Margin (dB)	Antenna Height (m)	Table Angle (Degree)	Raw Value (dBuV)	Correction Factor (dB/m)
1	*2480.00	81.65 PK			1.25 H	22	50.10	31.55
1	*2480.00	51.65 AV			1.25 H	22	20.10	31.55
2	4960.00	50.50 PK	74.00	-23.50	1.27 H	24	12.30	38.20
2	4960.00	20.50 AV	54.00	-33.50	1.27 H	24	-17.70	38.20

<b>ANTENNA POLARITY &amp; TEST DISTANCE: VERTICAL AT 3 M</b>								
No.	Freq. (MHz)	Emission Level (dBuV/m)	Limit (dBuV/m)	Margin (dB)	Antenna Height (m)	Table Angle (Degree)	Raw Value (dBuV)	Correction Factor (dB/m)
1	*2480.00	85.27 PK			1.32 V	229	53.72	31.55
1	*2480.00	55.27 AV			1.32 V	229	23.72	31.55
2	4960.00	50.63 PK	74.00	-23.37	1.25 V	172	12.43	38.20
2	4960.00	20.63 AV	54.00	-33.37	1.25 V	172	-17.57	38.20

- REMARKS:**
1. Emission level(dBuV/m)=Raw Value(dBuV) + Correction Factor(dB/m)
  2. Correction Factor(dB/m) = Antenna Factor (dB/m) + Cable Factor (dB)
  3. The other emission levels were very low against the limit.
  4. Margin value = Emission level – Limit value.
  5. “ \* “ : Fundamental frequency
  6. The DH5 packet was the worse case duty cycle for a transmit dwell time on a channel, based upon bluetooth theory the transmitter is on 0.625\*5 per 247 ms per channel. Therefore, the duty cycle be equal to:  $20\log(3.125/100) = -30\text{dB}$
  7. Average value = peak reading  $-20\log(\text{duty cycle})$



### 4.3 NUMBER OF HOPPING FREQUENCY USED

#### 4.3.1 LIMITS OF HOPPING FREQUENCY USED

At least 15 hopping frequencies, and should be equally spaced.

#### 4.3.2 TEST INSTRUMENTS

Description & Manufacturer	Model No.	Serial No.	Calibrated Until
SPECTRUM ANALYZER	FSP 40	100035	Apr. 19, 2005

**NOTE:** The calibration interval of the above test instruments is 12 months and the calibrations are traceable to NML/ROC and NIST/USA.

#### 4.3.3 TEST PROCEDURE

1. Check the calibration of the measuring instrument (SA) using either an internal calibrator or a known signal from an external generator.
2. Turn on the EUT and connect its antenna terminal to measurement via a low loss cable. Then set it to any one measured frequency within its operating range and make sure the instrument is operated in its linear range.
3. Set the SA on MaxHold Mode, and then keep the EUT in hopping mode. Record all the signals from each channel until each one has been recorded.
4. Set the SA on View mode and then plot the result on SA screen.
5. Repeat above procedures until all frequencies measured were complete.

#### 4.3.4 DEVIATION FROM TEST STANDARD

No deviation.



#### 4.3.5 TEST SETUP



For the actual test configuration, please refer to the related Item – Photographs of the Test Configuration.

#### 4.3.6 TEST RESULTS

There are 79 hopping frequencies in the hopping mode. Please refer to next two pages for the test result. On the plots, it shows that hopping frequencies are equally spaced.

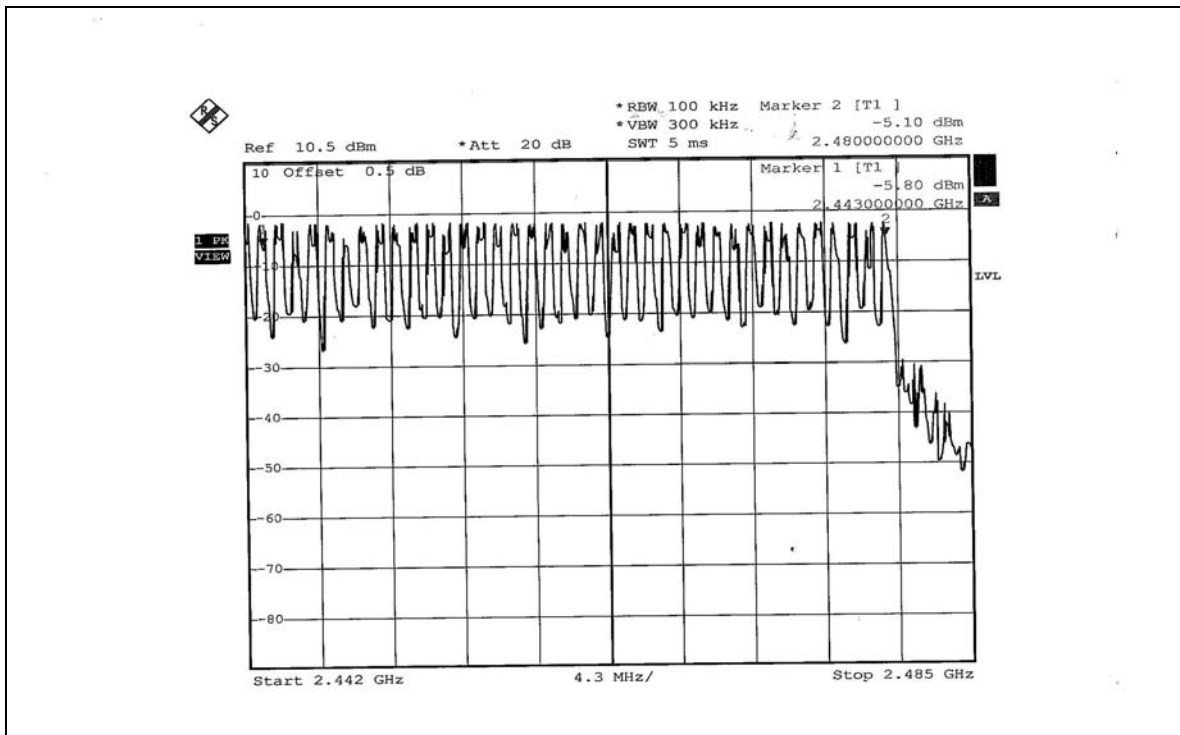
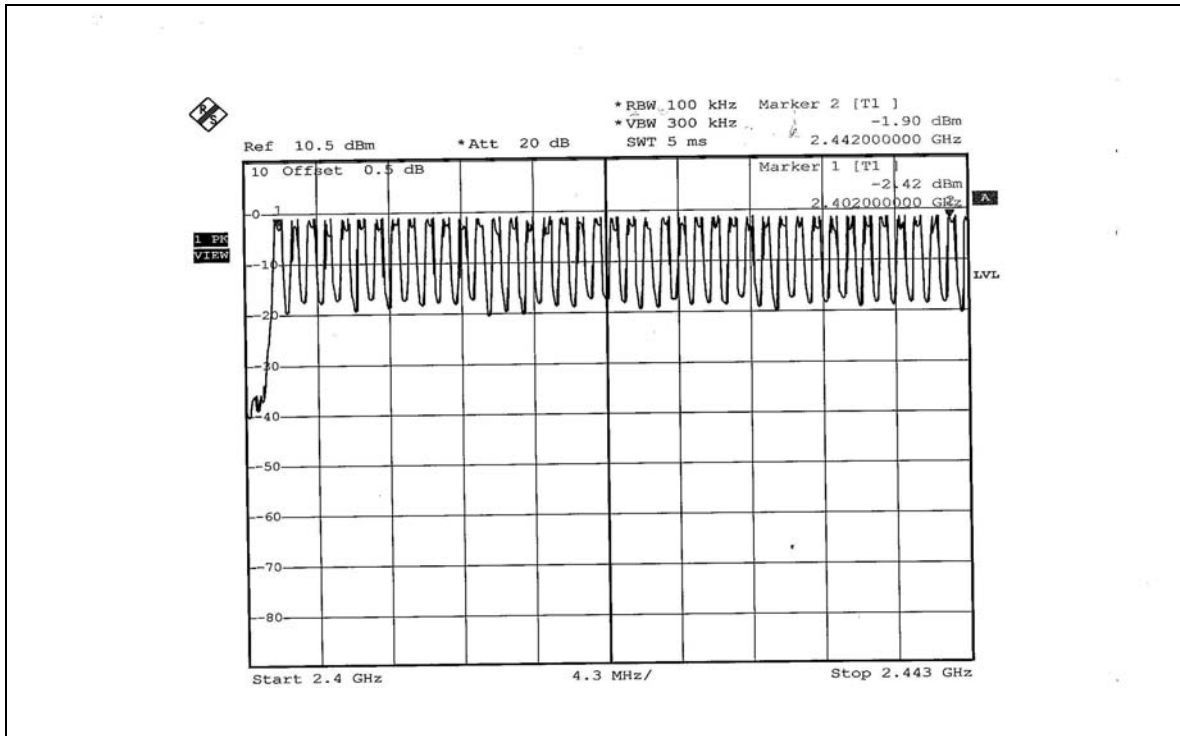



## 4.4 DWELL TIME ON EACH CHANNEL

### 4.4.1 LIMITS OF DWELL TIME USED

For FHSS, the average time of occupancy on any frequency shall not be greater than 0.4 seconds within a 31.6 second period. For hybrid systems, the average time of occupancy on any frequency should not exceed 0.4 seconds within a time period in seconds equal to the number of hopping frequencies employed multiplied by 0.4

### 4.4.2 TEST INSTRUMENTS

Description & Manufacturer	Model No.	Serial No.	Calibrated Until
SPECTRUM ANALYZER	FSP 40	100035	Apr. 19, 2005

**NOTE:** The calibration interval of the above test instruments is 12 months and the calibrations are traceable to NML/ROC and NIST/USA.

### 4.4.3 TEST PROCEDURE

1. Check the calibration of the measuring instrument (SA) using either an internal calibrator or a known signal from an external generator.
2. Turn on the EUT and connect its antenna terminal to measurement via a low loss cable. Then set it to any one measured frequency within its operating range and make sure the instrument is operated in its linear range.
3. Adjust the center frequency of SA on any frequency be measured and set SA to zero span mode. And then, set RBW and VBW of spectrum analyzer to proper value.
4. Measure the time duration of one transmission on the measured frequency. And then plot the result with time difference of this time duration.
5. Repeat above procedures until all frequencies measured were complete.



**4.4.4 DEVIATION FROM TEST STANDARD**

No deviation.

**4.4.5 TEST SETUP**

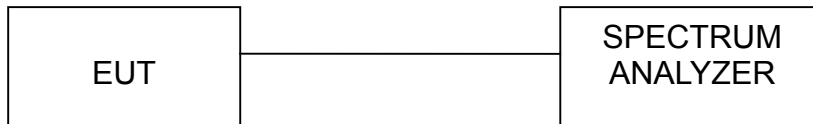

For the actual test configuration, please refer to the related Item – Photographs of the Test Configuration.

**4.4.6 TEST RESULTS**

Mode	Number of transmission in a 31.6 (79Hopping*0.4)	Length of transmission time (msec)	Result (msec)	Limit (msec)
DH1	51 (times / 5 sec) *6.32= 322.32 times	0.461	148.59	400
DH3	26 (times / 5 sec) *6.32= 164.32 times	1.703	279.94	400
DH5	17 (times / 5 sec) *6.32= 107.44 times	2.936	315.44	400

Test plots of the transmitting time slot are shown on next six pages.



DH1

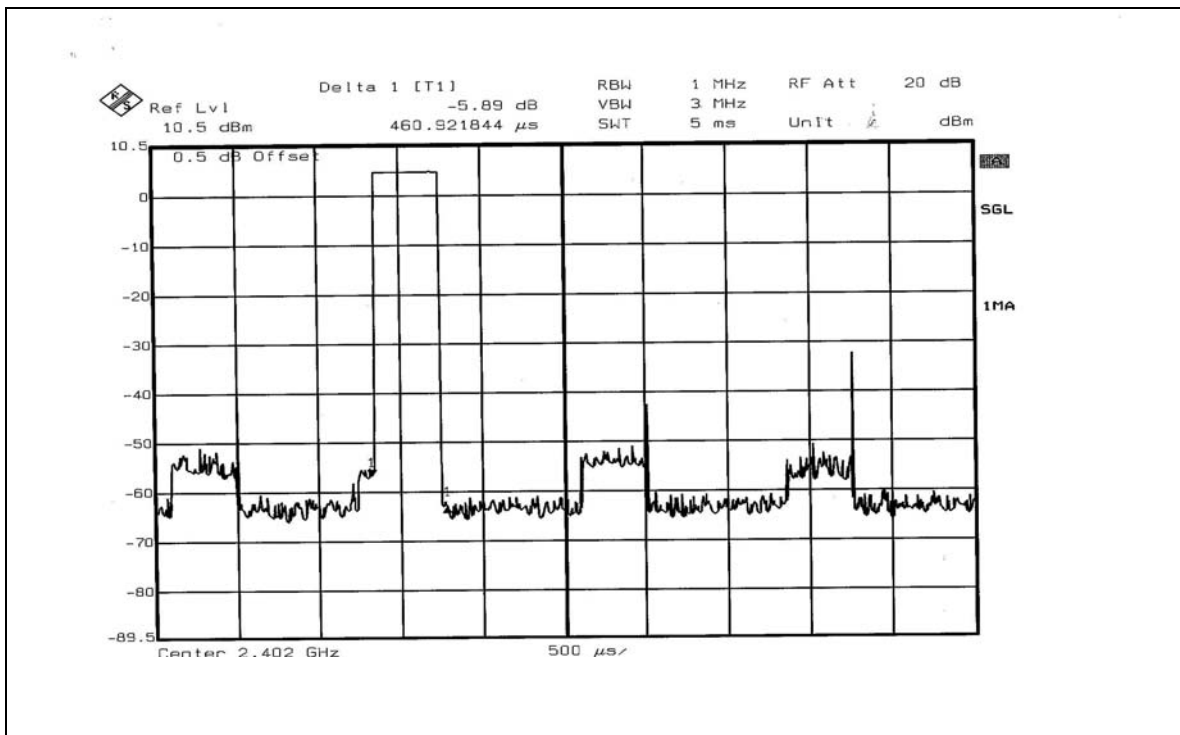
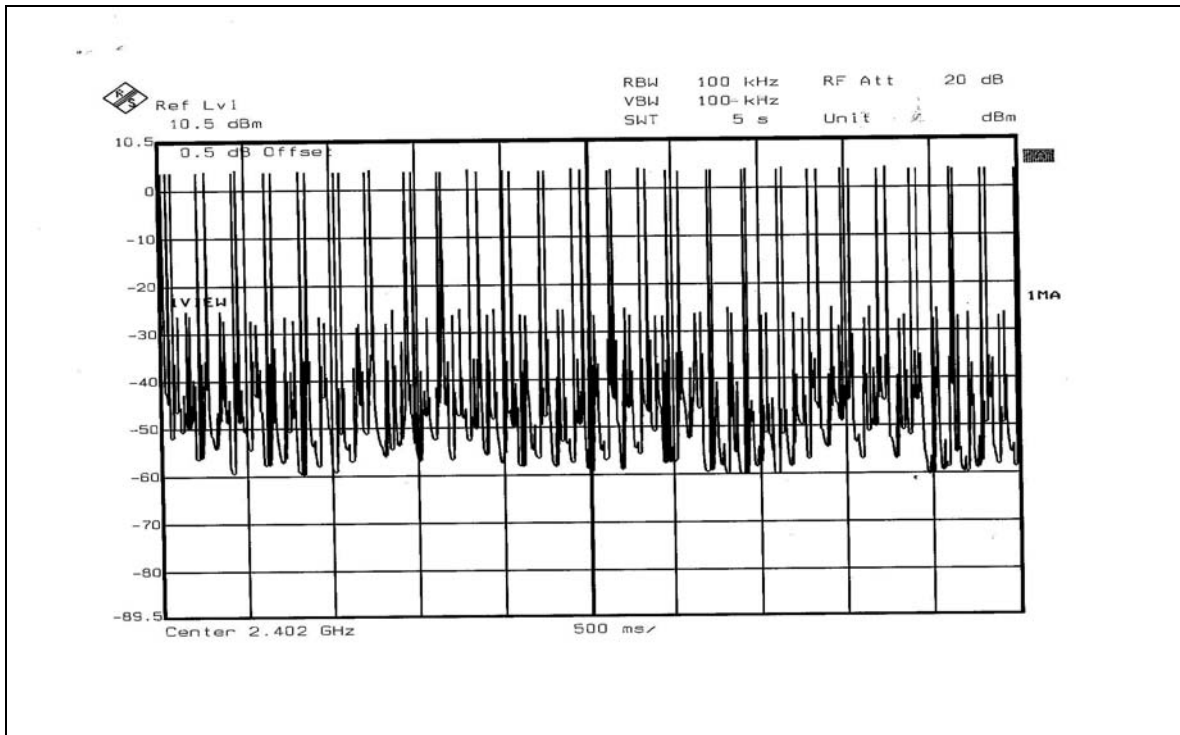



DH3

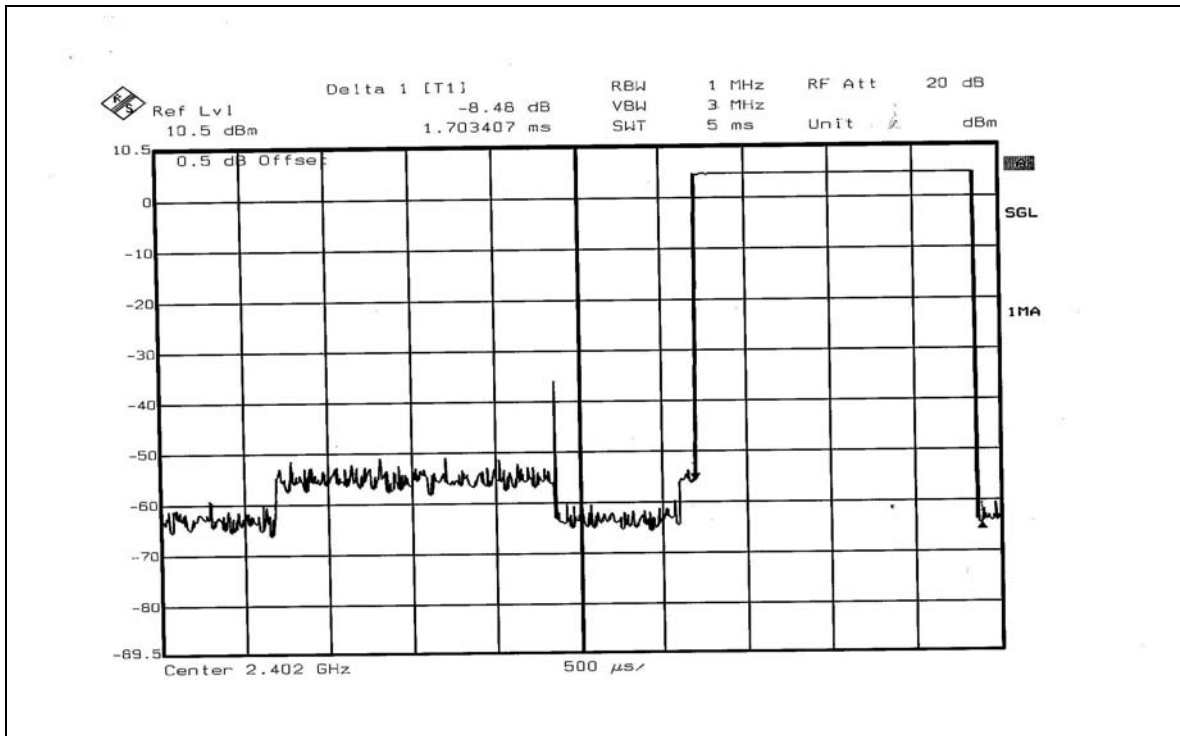
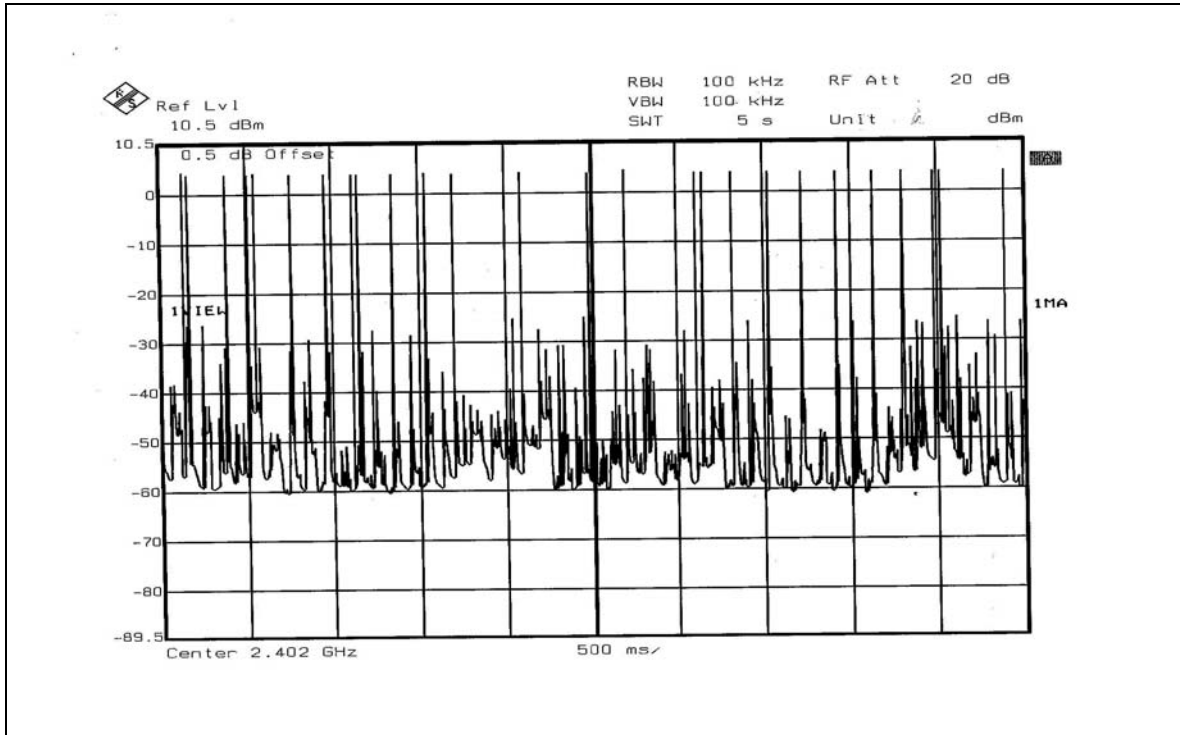



DH5

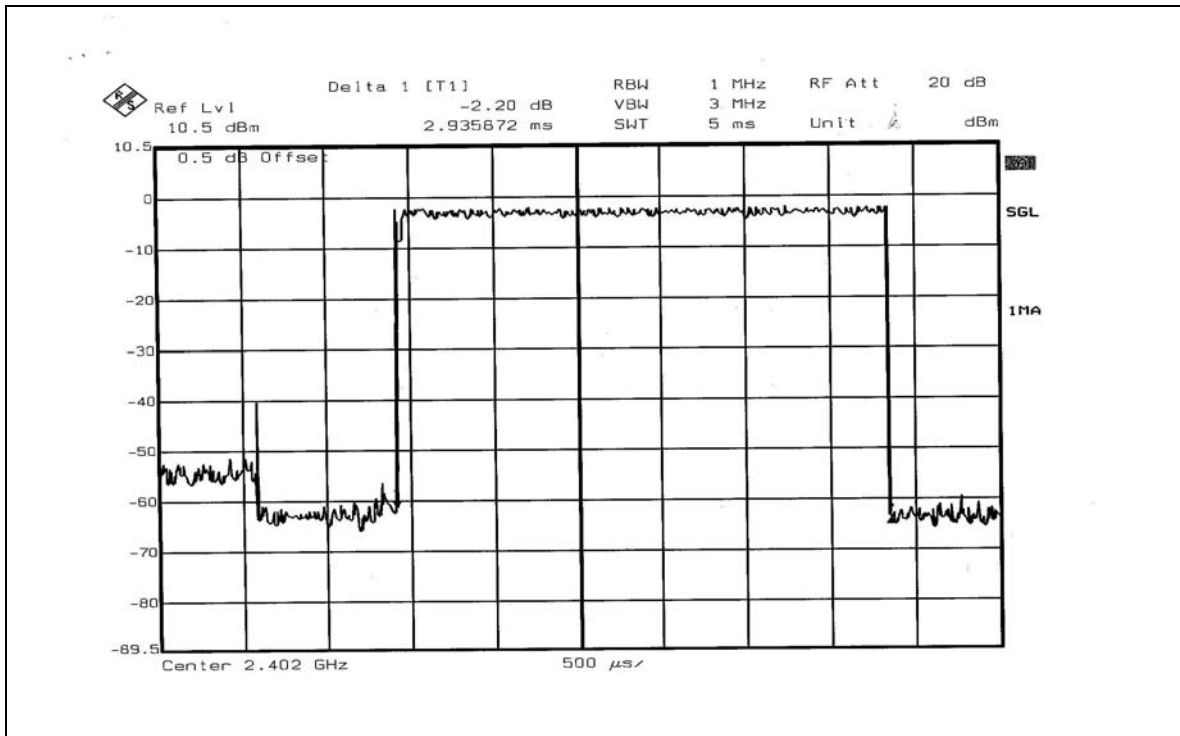
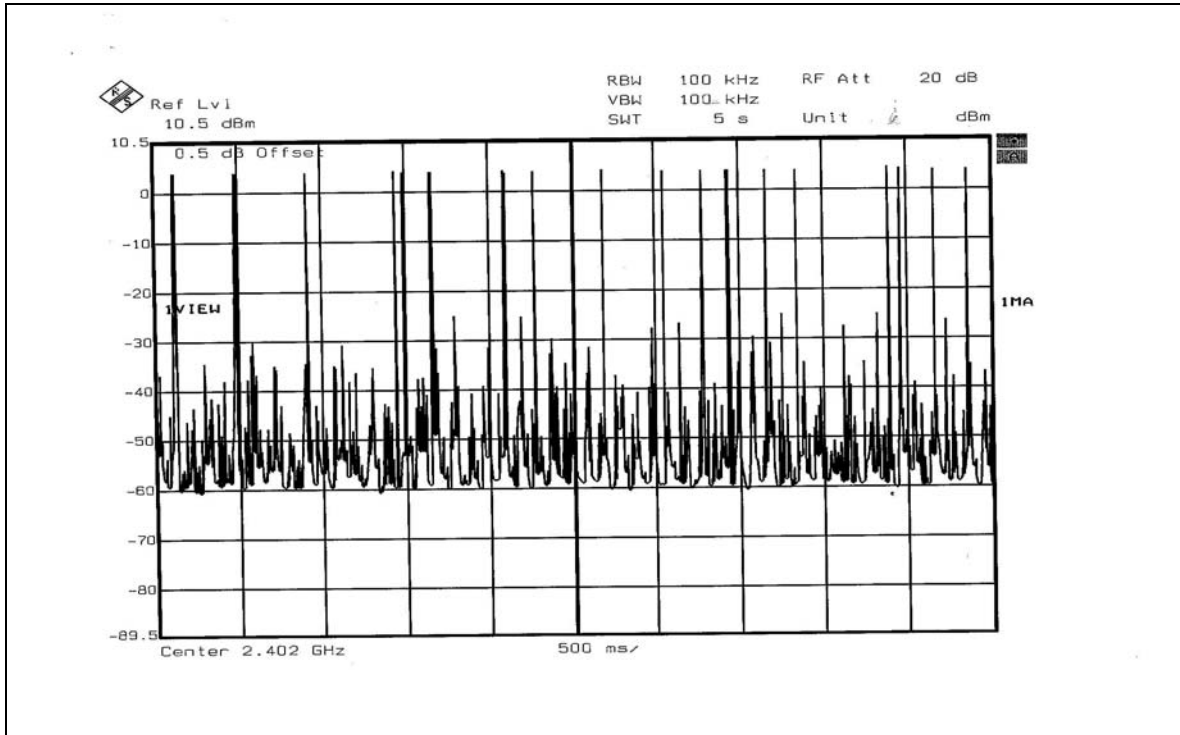



## 4.5 CHANNEL BANDWIDTH

### 4.5.1 LIMITS OF CHANNEL BANDWIDTH

For frequency hopping system operating in the 2400-2483.5MHz, If the 20dB bandwidth of hopping channel is greater than 25kHz, the 20dB bandwidth of hopping channel shall be a minimum limit for the hopping channel separation.

### 4.5.2 TEST INSTRUMENTS

Description & Manufacturer	Model No.	Serial No.	Calibrated Until
SPECTRUM ANALYZER	FSP 40	100035	Apr. 19, 2005

**NOTE:** The calibration interval of the above test instruments is 12 months and the calibrations are traceable to NML/ROC and NIST/USA.

### 4.5.3 TEST PROCEDURE

1. Check the calibration of the measuring instrument using either an internal calibrator or a known signal from an external generator.
2. Turn on the EUT and connect it to measurement instrument. Then set it to any one convenient frequency within its operating range. Set a reference level on the measuring instrument equal to the highest peak value.
3. Measure the frequency difference of two frequencies that were attenuated 20dB from the reference level. Record the frequency difference as the emission bandwidth.
4. Repeat above procedures until all frequencies measured were complete.

### 4.5.4 DEVIATION FROM TEST STANDARD

No deviation.





#### 4.5.5 TEST SETUP

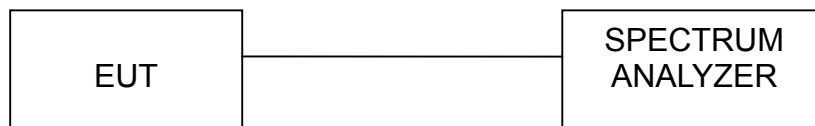

#### 4.5.6 EUT OPERATING CONDITION

The software provided by client enabled the EUT to transmit and receive data at lowest, middle and highest channel frequencies individually.



#### 4.5.7 TEST RESULTS

<b>EUT</b>	PDT ( Portable Data Terminal )	<b>MODEL</b>	IT7000
<b>ENVIRONMENTAL CONDITIONS</b>	23 deg. C, 69% RH, 991 hPa	<b>INPUT POWER (SYSTEM)</b>	120Vac, 60Hz
<b>TESTED BY</b>	Leo Hung		

Channel	Channel Frequency (MHz)	20dB Bandwidth (kHz)	More Than 25kHz
0	2402	675	Yes
39	2441	684	Yes
78	2480	681	Yes



CH0

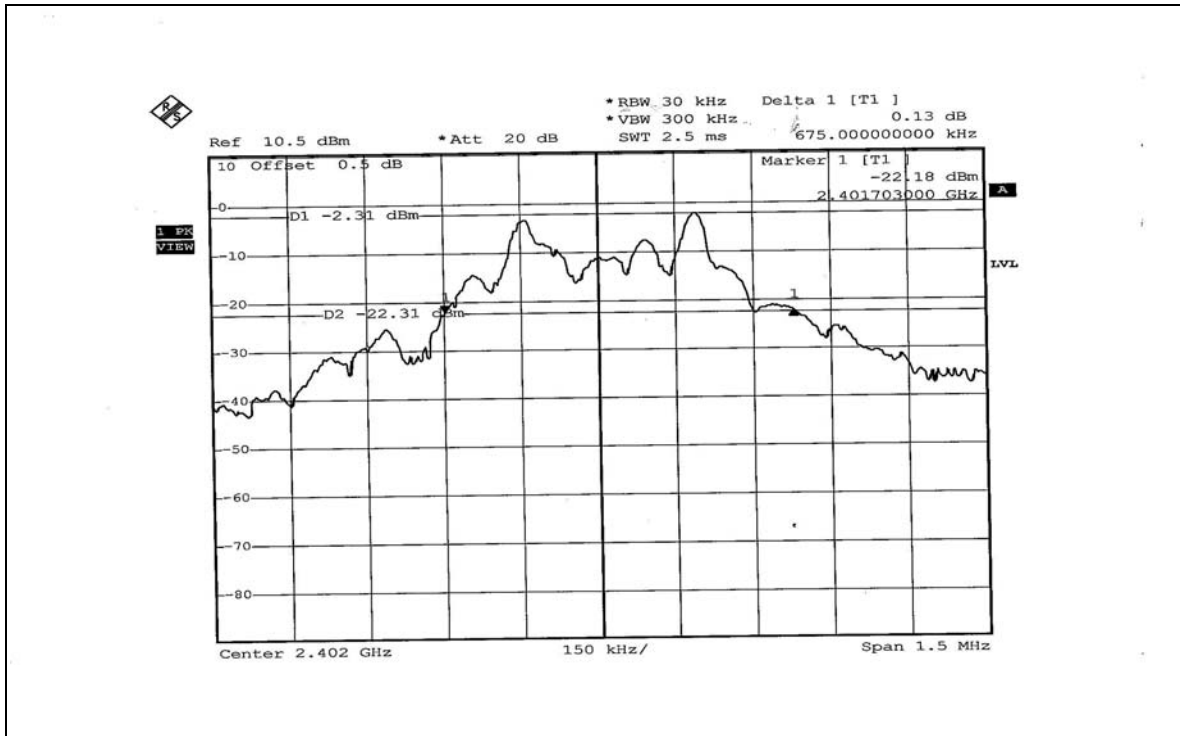

CH39

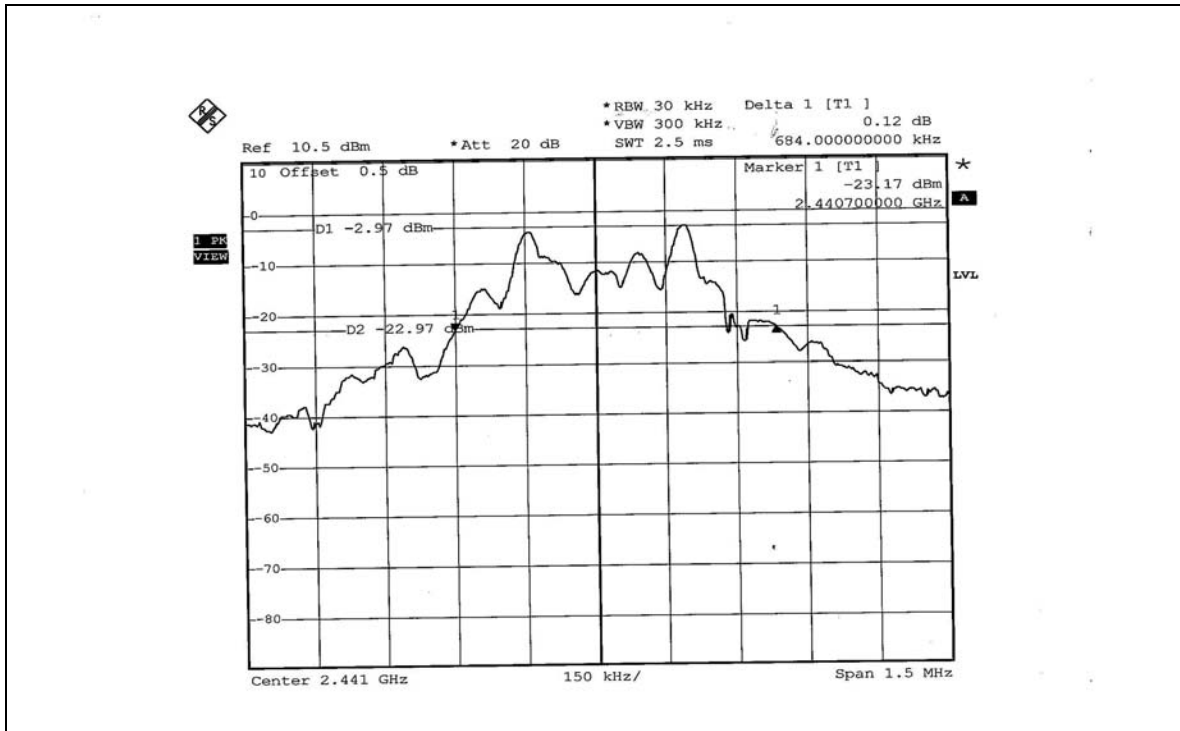



CH78

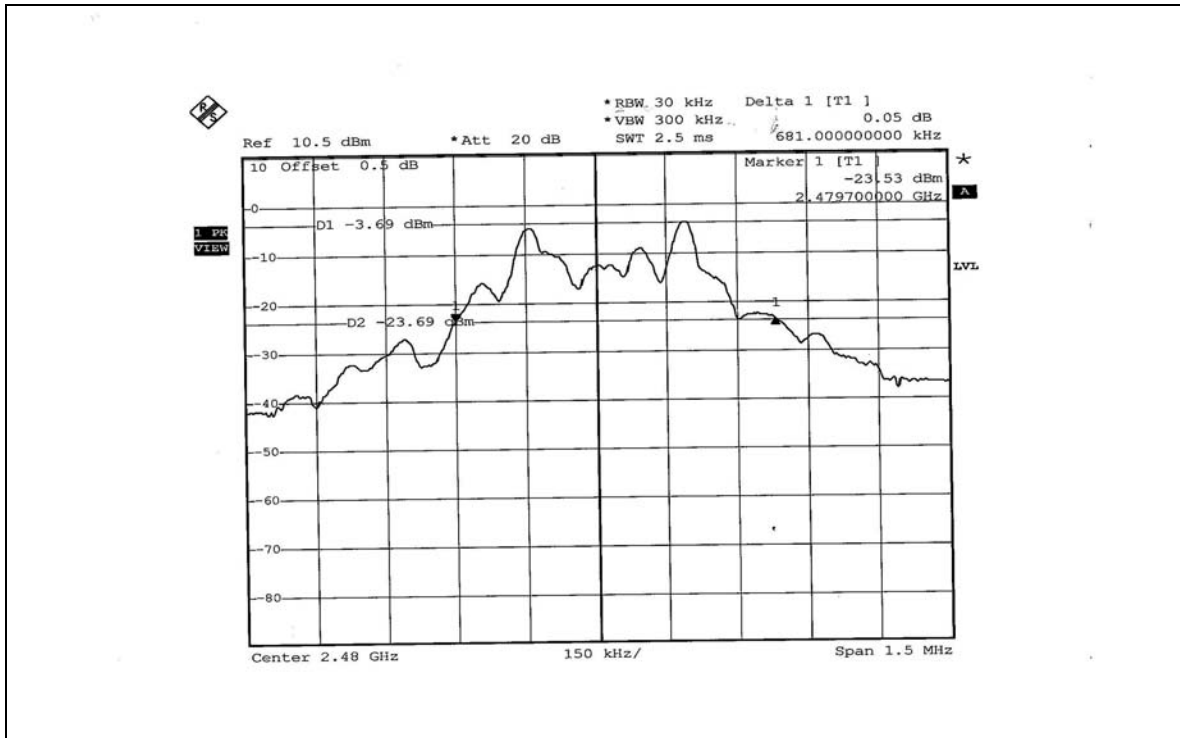



## 4.6 HOPPING CHANNEL SEPARATION

### 4.6.1 LIMITS OF HOPPING CHANNEL SEPARATION

At least 25kHz or 20dB bandwidth (whichever is greater).

### 4.6.2 TEST INSTRUMENTS

Description & Manufacturer	Model No.	Serial No.	Calibrated Until
SPECTRUM ANALYZER	FSP 40	100035	Apr. 19, 2005

**NOTE:** The calibration interval of the above test instruments is 12 months and the calibrations are traceable to NML/ROC and NIST/USA.

### 4.6.3 TEST PROCEDURE

1. Check the calibration of the measuring instrument using either an internal calibrator or a known signal from an external generator.
2. Turn on the EUT and connect it to measurement instrument. Then set it to any one convenient frequency within its operating range.
3. By using the MaxHold function record the separation of two adjacent channels.
4. Measure the frequency difference of these two adjacent channels by SA MARK function. And then plot the result on SA screen.
5. Repeat above procedures until all frequencies measured were complete.

### 4.6.4 DEVIATION FROM TEST STANDARD

No deviation.



**4.6.5 TEST SETUP**



For the actual test configuration, please refer to the related Item – Photographs of the Test Configuration.

**4.6.6 TEST RESULTS**

<b>EUT</b>	PDT ( Portable Data Terminal )	<b>MODEL</b>	IT7000
<b>ENVIRONMENTAL CONDITIONS</b>	23 deg. C, 69%RH, 991 hPa	<b>INPUT POWER (SYSTEM)</b>	120Vac, 60 Hz
<b>TESTED BY</b>	Leo Hung		

<b>CHANNEL</b>	<b>FREQUENCY (MHz)</b>	<b>ADJACENT CHANNEL SEPARATION</b>	<b>MINIMUM LIMIT (kHz)</b>	<b>PASS/FAIL</b>
0	2402	1.010MHz	675	PASS
39	2441	1.035MHz	684	PASS
78	2480	1.012MHz	681	PASS

The minimum limit is 20dB bandwidth. Test results please refer to next three pages.



CH0

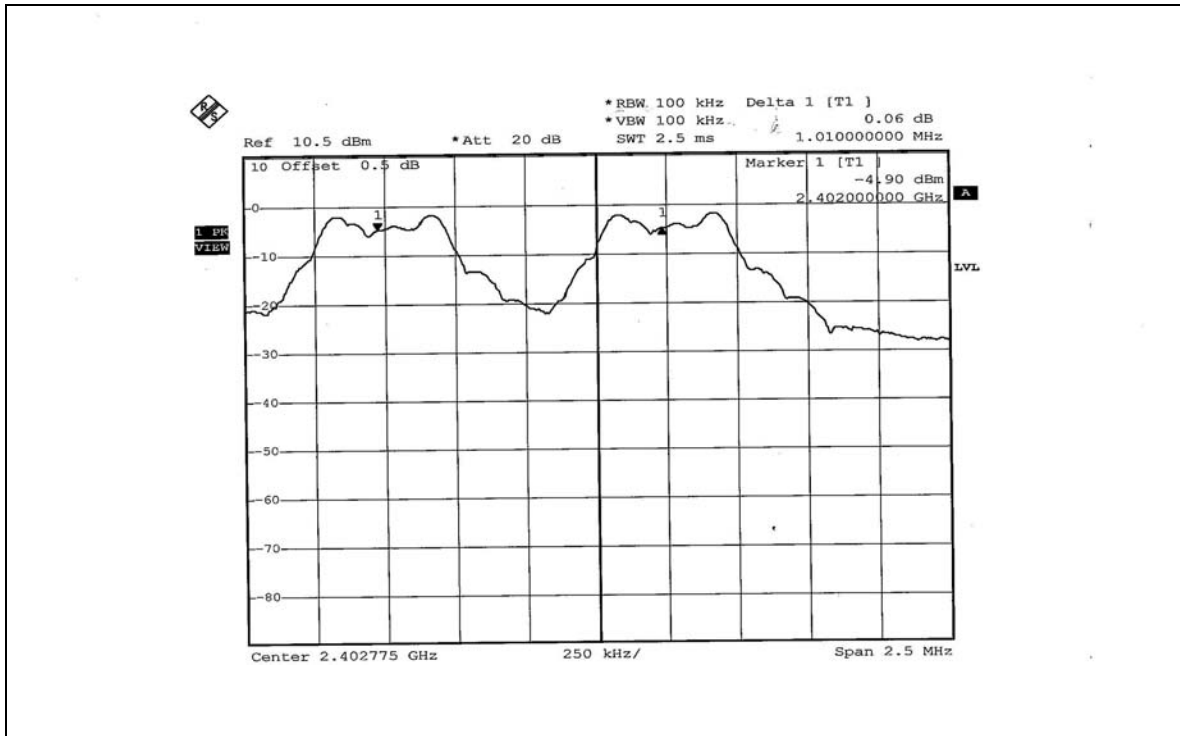

CH39

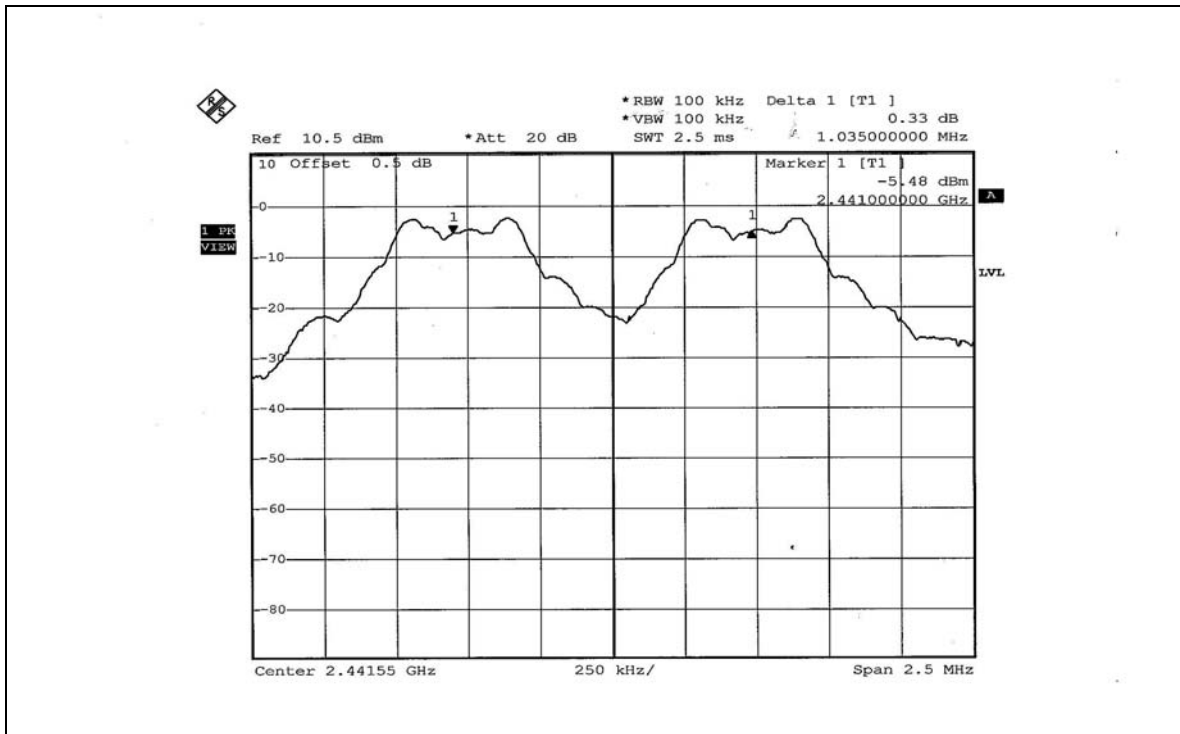



CH78

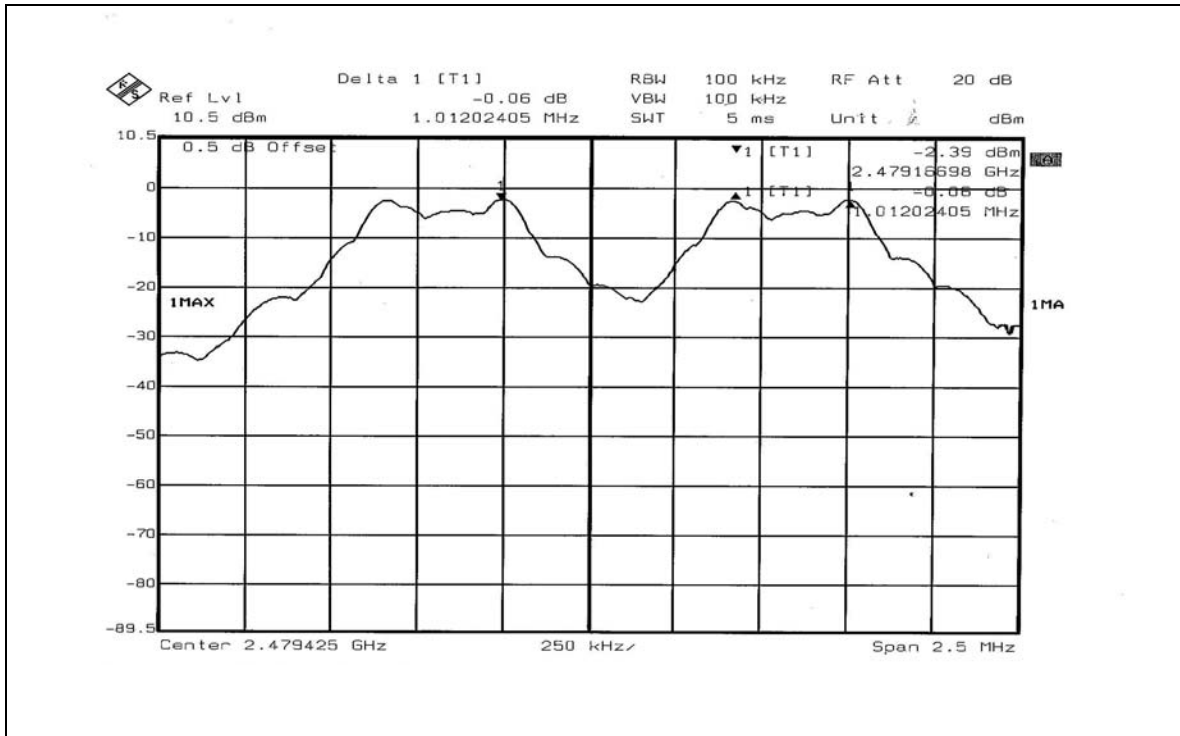





## 4.7 MAXIMUM PEAK OUTPUT POWER

### 4.7.1 LIMITS OF MAXIMUM PEAK OUTPUT POWER MEASUREMENT

The limit of Maximum Peak Output Power Measurement is 30dBm.

### 4.7.2 TEST INSTRUMENTS

Description & Manufacturer	Model No.	Serial No.	Calibrated Until
SPECTRUM ANALYZER	FSP 40	100035	Apr. 19, 2005

**NOTE:** The calibration interval of the above test instruments is 12 months and the calibrations are traceable to NML/ROC and NIST/USA.

### 4.7.3 TEST PROCEDURE

1. Check the calibration of the measuring instrument (SA) using either an internal calibrator or a known signal from an external generator.
2. Turn on the EUT and connect it to measurement instrument. Then set it to any one convenient frequency within its operating range. Set a reference level on the measuring instrument equal to the highest peak value.
3. The center frequency of the spectrum analyzer is set to the fundamental frequency and using 1 MHz RBW and 3 MHz VBW.
4. Measure the frequency difference of two frequencies that were attenuated 20dB from the reference level. Record the frequency difference as the emission bandwidth.
5. Repeat above procedures until all frequencies measured were complete.

### 4.7.4 DEVIATION FROM TEST STANDARD

No deviation.



**4.7.5 TEST SETUP**



For the actual test configuration, please refer to the related Item – Photographs of the Test Configuration.

**4.7.6 TEST RESULTS**

<b>EUT</b>	PDT ( Portable Data Terminal )	<b>MODEL</b>	IT7000
<b>ENVIRONMENTAL CONDITIONS</b>	23 deg. C, 69% RH, 991 hPa	<b>INPUT POWER (SYSTEM)</b>	120Vac, 60 Hz
<b>TESTED BY</b>	Leo Hung		

CHANNEL	CHANNEL FREQUENCY (MHz)	PEAK POWER OUTPUT (mW)	PEAK POWER OUTPUT (dBm)	PEAK POWER LIMIT (dBm)	PASS/FAIL
0	2402	0.661	-1.80	30	PASS
39	2441	0.573	-2.42	30	PASS
78	2480	0.478	-3.21	30	PASS



CH0

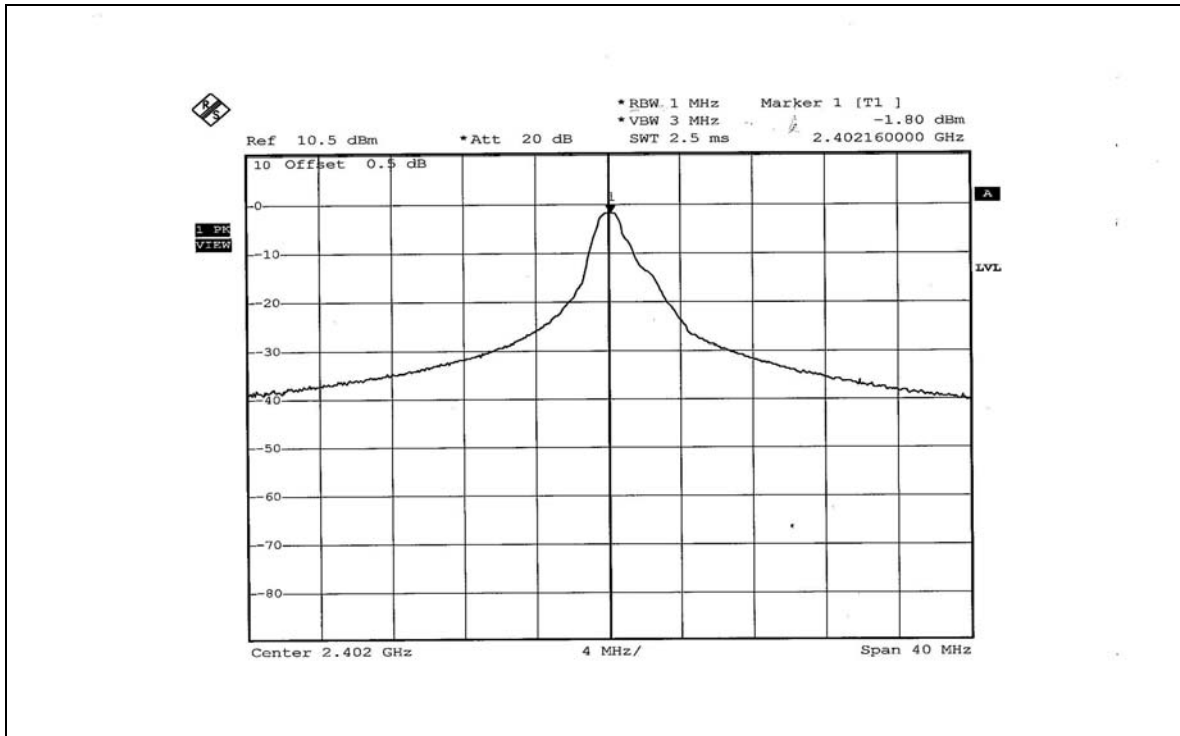

CH39

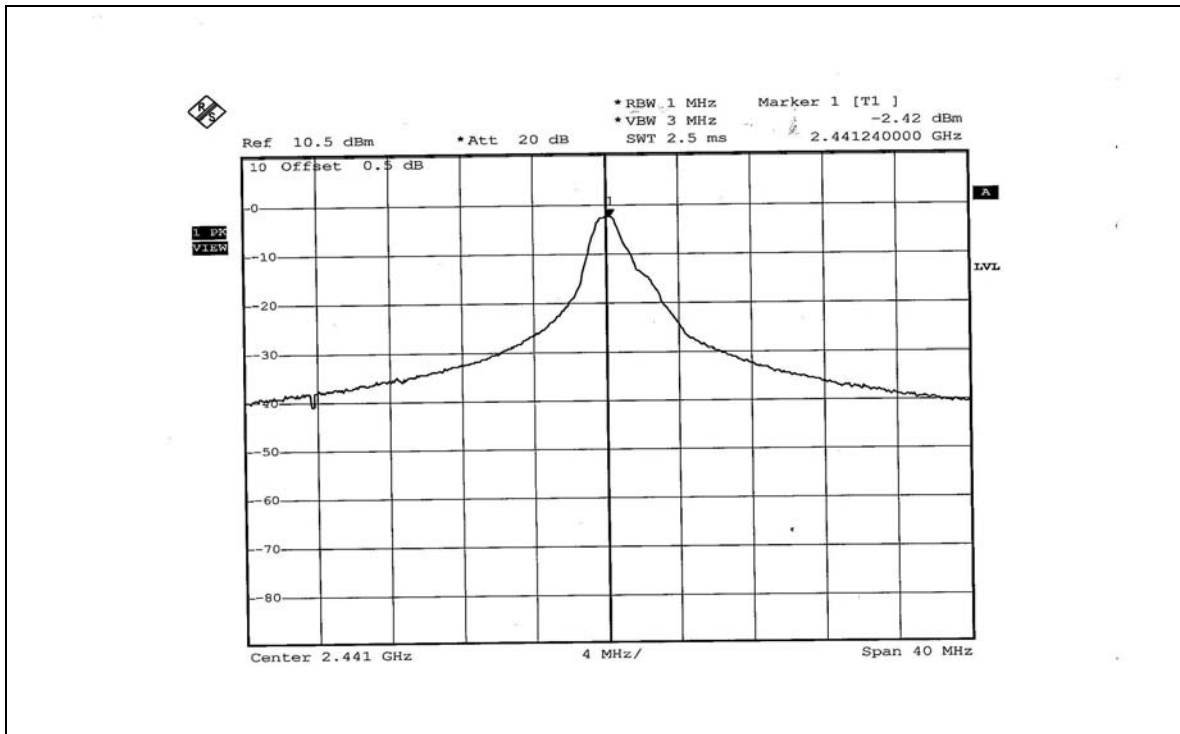



CH78

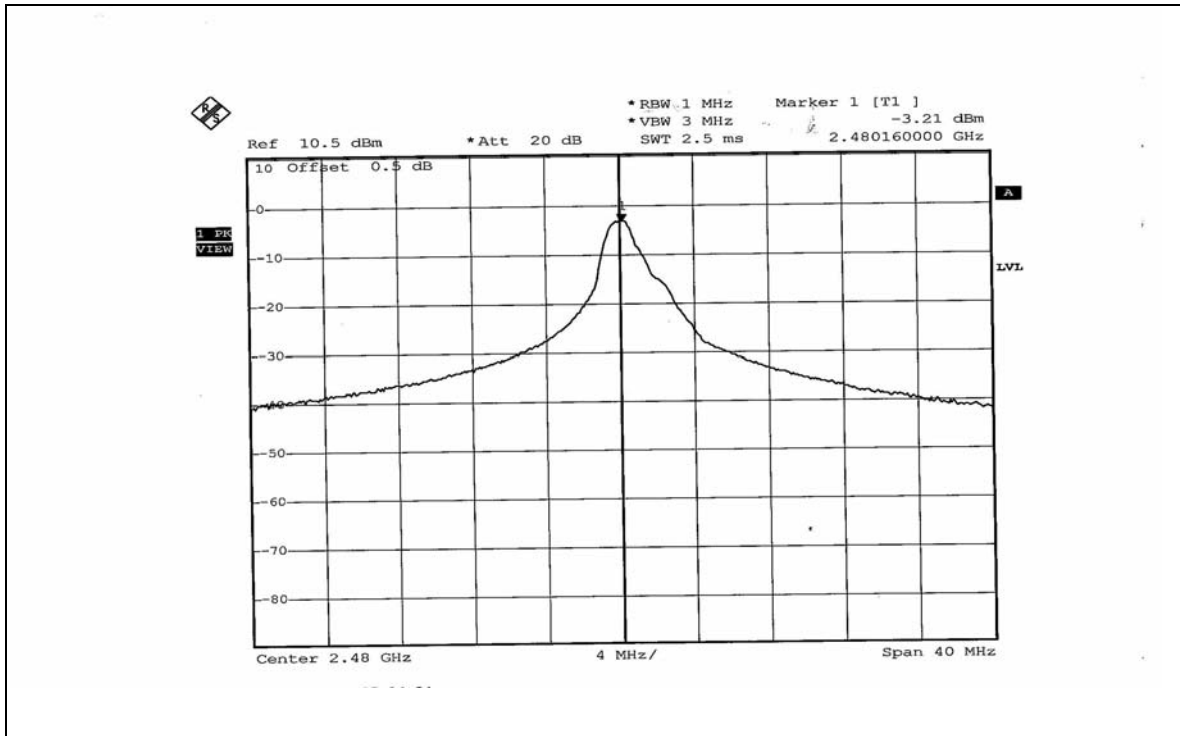



## 4.8 BAND EDGES MEASUREMENT

### 4.8.1 LIMITS OF BAND EDGES MEASUREMENT

Below –20dB of the highest emission level of operating band (in 100kHz Resolution Bandwidth).

### 4.8.2 TEST INSTRUMENTS

Description & Manufacturer	Model No.	Serial No.	Calibrated Until
SPECTRUM ANALYZER	FSP 40	100035	Apr. 19, 2005

**NOTE:** The calibration interval of the above test instruments is 12 months and the calibrations are traceable to NML/ROC and NIST/USA.

### 4.8.3 TEST PROCEDURE

The transmitter output was connected to the spectrum analyzer via a low lose cable. Set both RBW and VBW of spectrum analyzer to 100kHz with suitable frequency span including 100MHz bandwidth from band edge. The band edges was measured and recorded.

### 4.8.4 DEVIATION FROM TEST STANDARD

No deviation.

### 4.8.5 EUT OPERATING CONDITION

The software provided by client enabled the EUT to transmit and receive data at lowest, middle and highest channel frequencies individually.



#### 4.8.6 TEST RESULTS

The spectrum plots are attached on the following 6 pages. D2 line indicates the highest level, D1 line indicates the 20dB offset below D2. It shows compliance with the requirement in part 15.247(d).

##### NOTE 1:

The band edge emission plot of FHSS technique on page 63 shows 51.89dB between carrier maximum power and local maximum emission in restrict band (2.3816GHz).

The emission of carrier strength list in the test result of channel 0 at the item 4.2.10 is 91.46dBuV/m (Peak), so the maximum field strength in restrict band is  $91.46 - 51.89 = 39.57$ dBuV/m which is under 74dBuV/m limit.

The band edge emission plot of FHSS technique on page 63 shows 51.89dB between carrier maximum power and local maximum emission in restrict band (2.3816GHz).

The emission of carrier strength list in the test result of channel 0 at the item 4.2.10 is 61.46dBuV/m (Average), so the maximum field strength in restrict band is  $61.46 - 51.89 = 9.57$ dBuV/m which is under 54dBuV/m limit.

##### NOTE 2:

The band edge emission plot of FHSS technique on page 64 shows 39.27dB between carrier maximum power and local maximum emission in restrict band (2.4839GHz).

The emission of carrier strength list in the test result of channel 78 at the item 4.2.10 is 85.27dBuV/m (Peak), so the maximum field strength in restrict band is  $85.27 - 39.27 = 46.00$ dBuV/m which is under 74dBuV/m limit.

The band edge emission plot of FHSS technique on page 64 shows 39.27dB between carrier maximum power and local maximum emission in restrict band (2.4839GHz).

The emission of carrier strength list in the test result of channel 78 at the item 4.2.10 is 55.27dBuV/m (Average), so the maximum field strength in restrict band is  $55.27 - 39.27 = 16.00$ dBuV/m which is under 54dBuV/m limit.

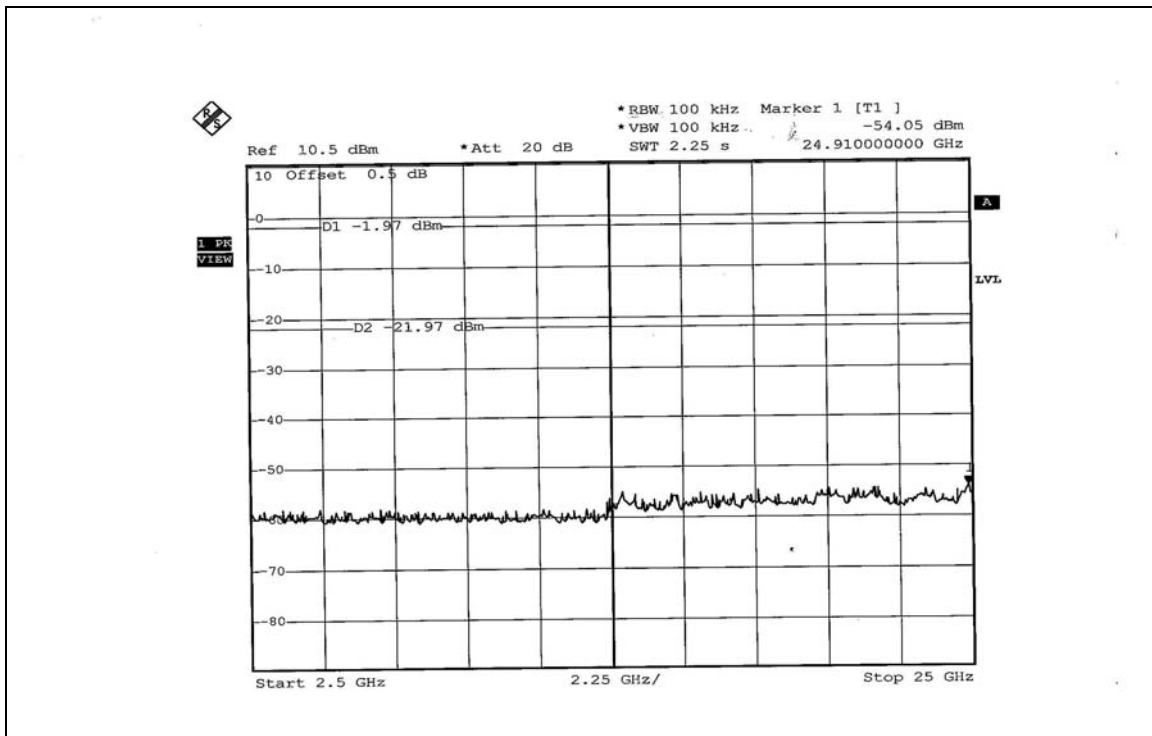
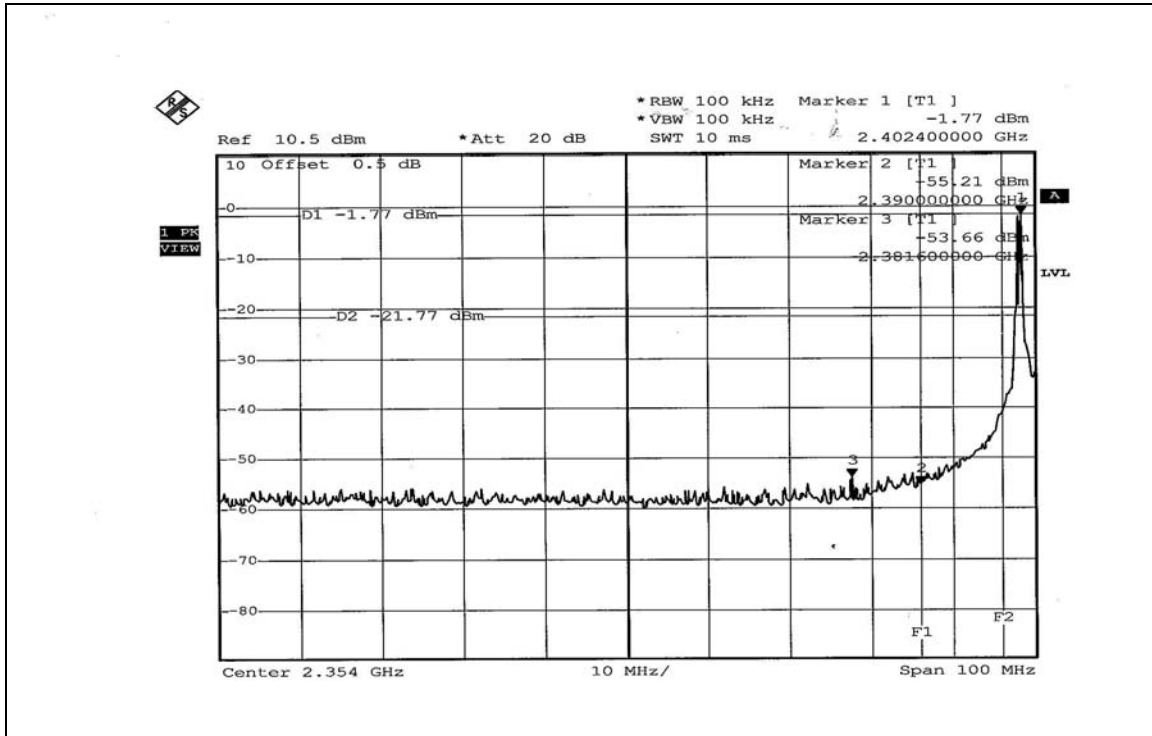

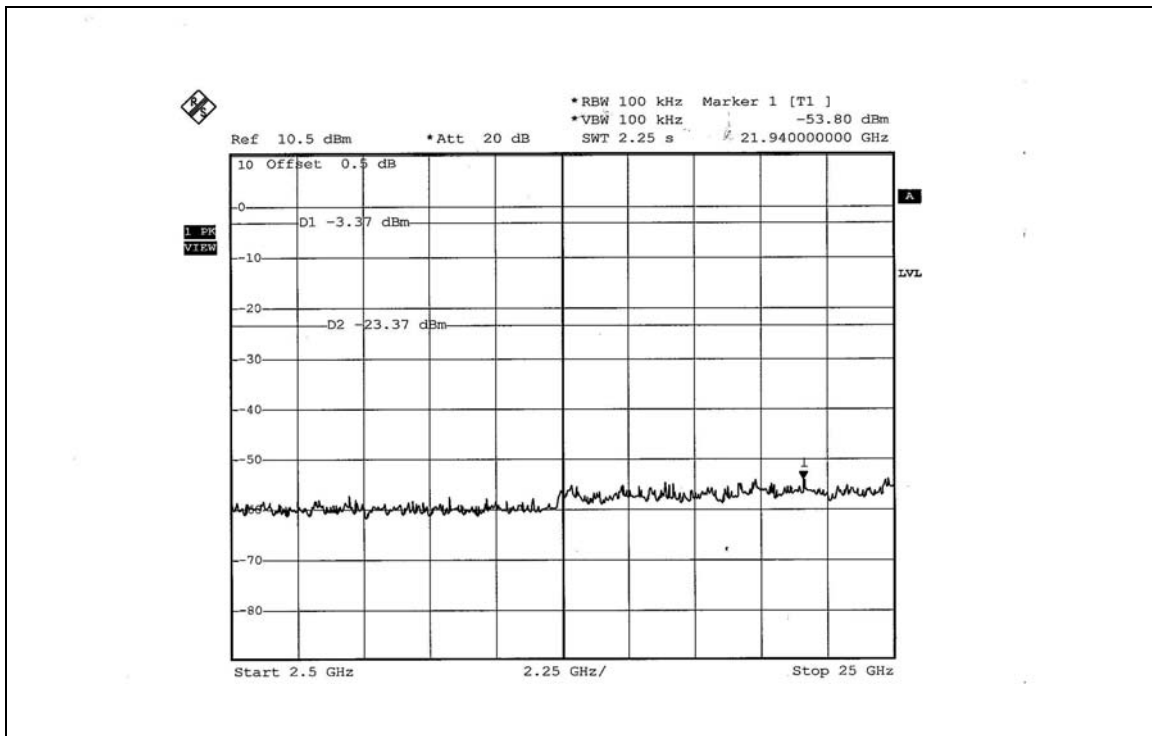
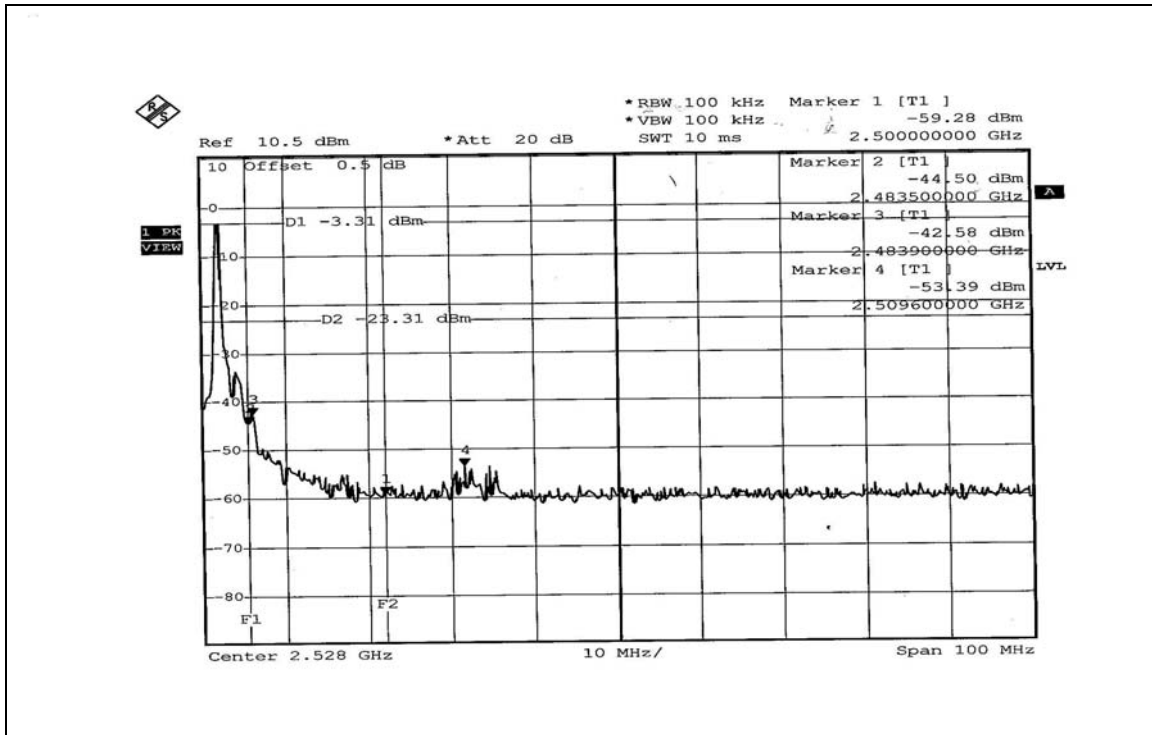





## **4.9 ANTENNA REQUIREMENT**

### **4.9.1 STANDARD APPLICABLE**

For intentional device, according to FCC 47 CFR Section 15.203, an intentional radiator shall be designed to ensure that no antenna other than that furnished by the responsible party shall be used with the device.

And according to FCC 47 CFR Section 15.247 (b), if transmitting antennas of directional gain greater than 6dBi are used, the power shall be reduced by the amount in dB that the directional gain of the antenna exceeds 6dBi.

### **4.9.2 ANTENNA CONNECTED CONSTRUCTION**

The antenna type used in this product is Chip antenna without antenna connector. The maximum gain of this antenna is  $-5.2\text{dBi}$ .

## 5 PHOTOGRAPHS OF THE TEST CONFIGURATION

### CONDUCTED EMISSION TEST (Test mode A)



### CONDUCTED EMISSION TEST (Test mode B)



### RADIATED EMISSION TEST (Test mode A)

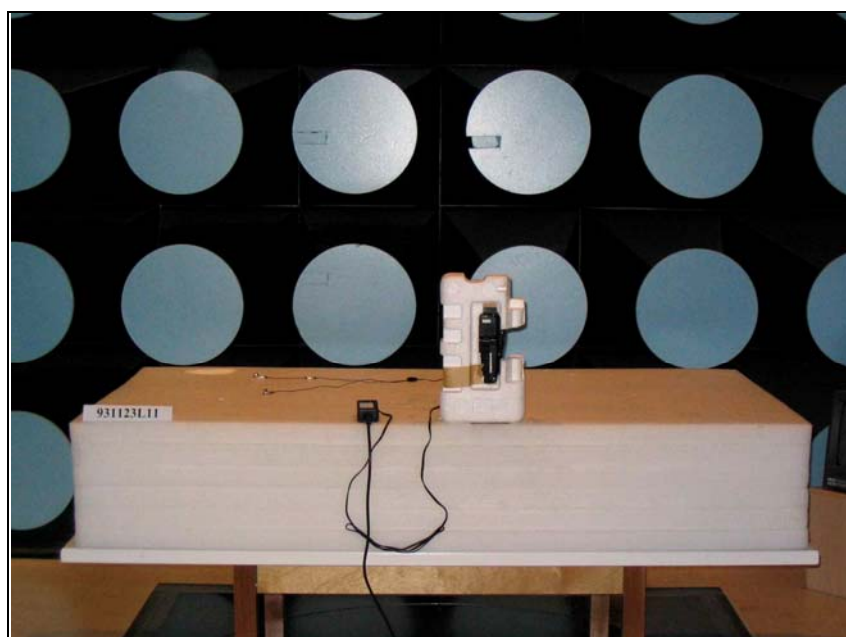
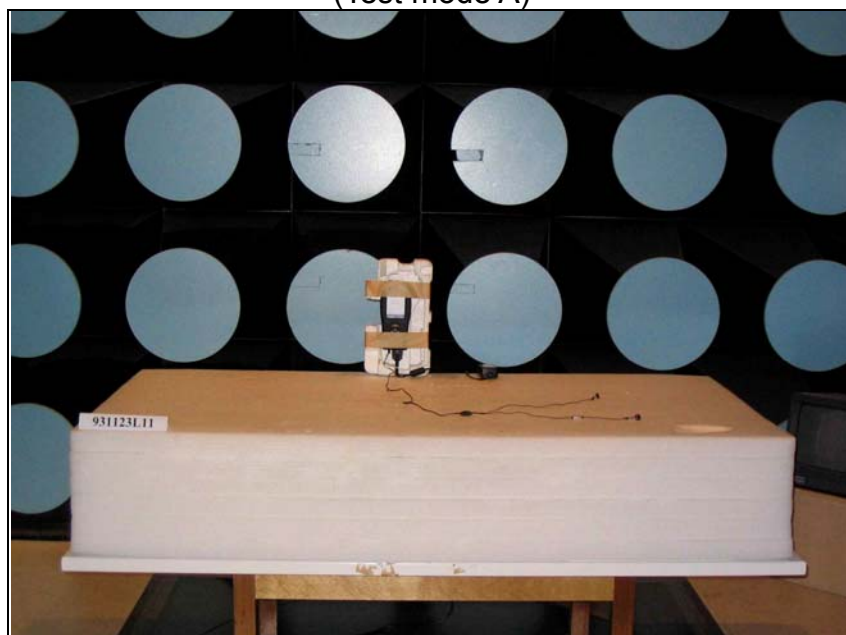

### RADIATED EMISSION TEST (Test mode B)

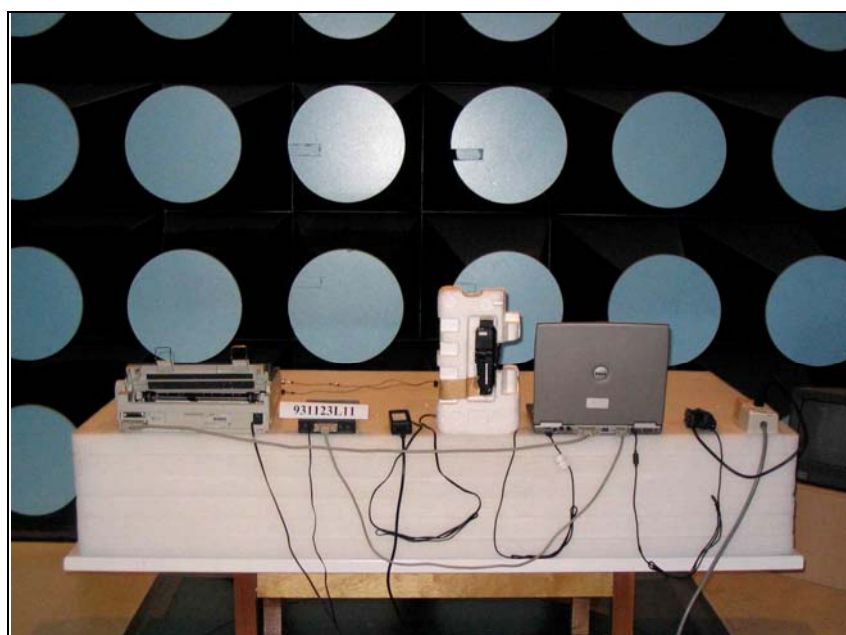
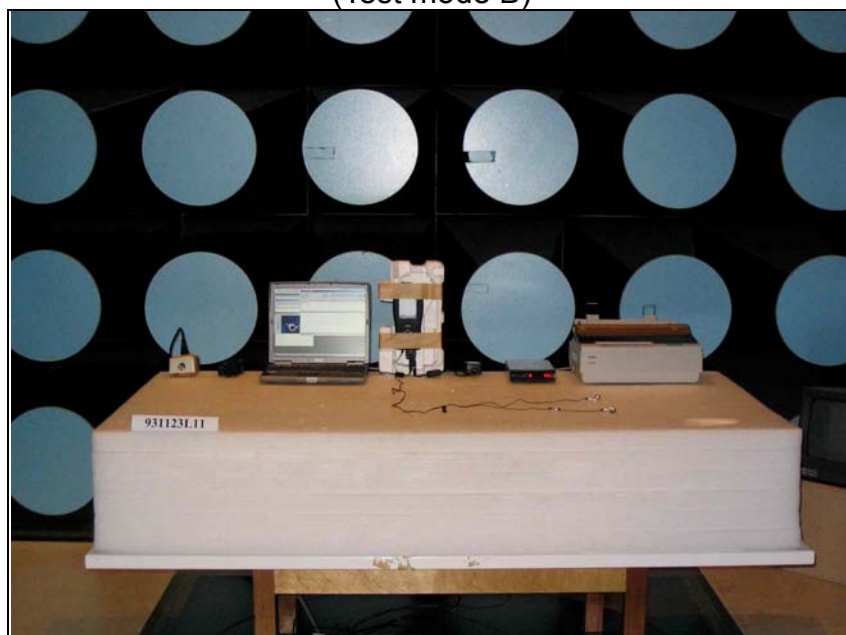

RADIATED EMISSION TEST  
(Test mode C)

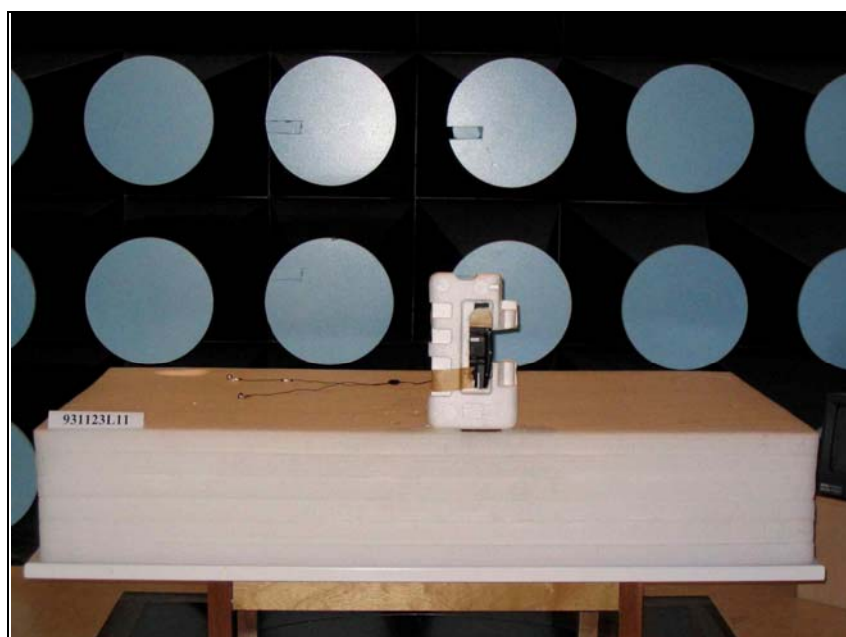
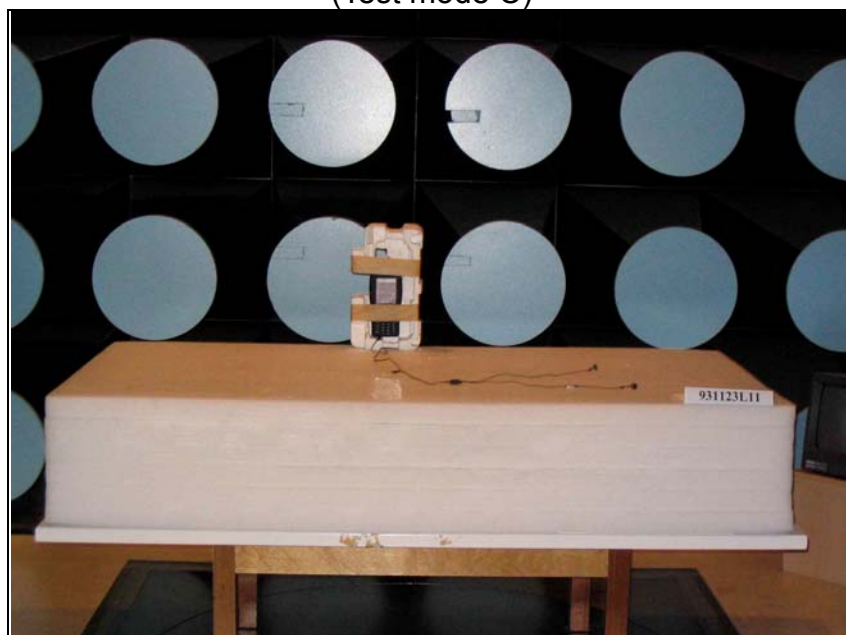



## 6 INFORMATION ON THE TESTING LABORATORIES

We, ADT Corp., were founded in 1988 to provide our best service in EMC, Radio, Telecom and Safety consultation. Our laboratories are accredited and approved by the following approval agencies according to ISO/IEC 17025:

<b>USA</b>	FCC, NVLAP, UL, A2LA
<b>Germany</b>	TUV Rheinland
<b>Japan</b>	VCCI
<b>Norway</b>	NEMKO
<b>Canada</b>	INDUSTRY CANADA , CSA
<b>R.O.C.</b>	CNLA, BSMI, DGT
<b>Netherlands</b>	Telefication
<b>Singapore</b>	PSB , GOST-ASIA(MOU)
<b>Russia</b>	CERTIS(MOU)

Copies of accreditation certificates of our laboratories obtained from approval agencies can be downloaded from our web site: [www.adt.com.tw/index.5/phtml](http://www.adt.com.tw/index.5/phtml).

If you have any comments, please feel free to contact us at the following:

**Linko EMC/RF Lab:**

Tel: 886-2-26052180

Fax: 886-2-26052943

**Hsin Chu EMC/RF Lab:**

Tel: 886-3-5935343

Fax: 886-3-5935342

**Hwa Ya EMC/RF/Safety/Telecom Lab:**

Tel: 886-3-3183232

Fax: 886-3-3185050

**Linko RF Lab.**

Tel: 886-3-3270910

Fax: 886-3-3270892

**Web Site:** [www.adt.com.tw](http://www.adt.com.tw)

The address and road map of all our labs can be found in our web site also.