



FCC TEST REPORT

REPORT NO.: RF970220L15

MODEL NO.: HWDN1 (refer to item 3.1 for more details)

RECEIVED: Feb. 20, 2008

TESTED: Feb. 21 ~ Mar. 07, 2008

ISSUED: Mar. 10, 2008

APPLICANT: Hawking Technologies, Inc.

ADDRESS: 15281A Barranca Pkwy, Irvine, CA 92618,
U.S.A.

ISSUED BY: Advance Data Technology Corporation

LAB ADDRESS: 47 14th Lin, Chiapau Tsun, Linko, Taipei, Taiwan,
R.O.C.

TEST LOCATION: No. 19, Hwa Ya 2nd Rd., Kueishan, Taoyuan,
Taiwan, R.O.C.

This test report consists of 94 pages in total. It may be duplicated completely for legal use with the approval of the applicant. It should not be reproduced except in full, without the written approval of our laboratory. The client should not use it to claim product endorsement by TAF, A2LA or any government agencies. The test results in the report only apply to the tested sample.





TABLE OF CONTENTS

1.	CERTIFICATION	4
2.	SUMMARY OF TEST RESULTS	5
2.1	MEASUREMENT UNCERTAINTY	5
3.	GENERAL INFORMATION	6
3.1	GENERAL DESCRIPTION OF EUT	6
3.2	DESCRIPTION OF TEST MODES	7
3.2.1	CONFIGURATION OF SYSTEM UNDER TEST	7
3.2.2	TEST MODE APPLICABILITY AND TESTED CHANNEL DETAIL	8
3.3	GENERAL DESCRIPTION OF APPLIED STANDARDS	10
3.4	DESCRIPTION OF SUPPORT UNITS	10
4.	TEST TYPES AND RESULTS	11
4.1	RADIATED EMISSION MEASUREMENT	11
4.1.1	LIMITS OF RADIATED EMISSION MEASUREMENT	11
4.1.2	TEST INSTRUMENTS	12
4.1.3	TEST PROCEDURES	13
4.1.4	DEVIATION FROM TEST STANDARD	13
4.1.5	TEST SETUP	14
4.1.6	EUT OPERATING CONDITIONS	14
4.1.7	TEST RESULTS	15
4.2	CONDUCTED EMISSION MEASUREMENT	32
4.2.1	LIMITS OF CONDUCTED EMISSION MEASUREMENT	32
4.2.2	TEST INSTRUMENTS	32
4.2.3	TEST PROCEDURES	33
4.2.4	DEVIATION FROM TEST STANDARD	33
4.2.5	TEST SETUP	34
4.2.6	EUT OPERATING CONDITIONS	34
4.2.7	TEST RESULTS	35
4.3	6dB BANDWIDTH MEASUREMENT	37
4.3.1	LIMITS OF 6dB BANDWIDTH MEASUREMENT	37
4.3.2	TEST INSTRUMENTS	37
4.3.3	TEST PROCEDURE	37
4.3.4	DEVIATION FROM TEST STANDARD	37
4.3.5	TEST SETUP	38
4.3.6	EUT OPERATING CONDITIONS	38
4.3.7	TEST RESULTS	39
4.4	MAXIMUM PEAK OUTPUT POWER	53
4.4.1	LIMITS OF MAXIMUM PEAK OUTPUT POWER MEASUREMENT	53
4.4.2	INSTRUMENTS	53
4.4.3	TEST PROCEDURES	53
4.4.4	DEVIATION FROM TEST STANDARD	53
4.4.5	TEST SETUP	54
4.4.6	EUT OPERATING CONDITIONS	54



4.4.7	TEST RESULTS	55
4.5	POWER SPECTRAL DENSITY MEASUREMENT	57
4.5.1	LIMITS OF POWER SPECTRAL DENSITY MEASUREMENT	57
4.5.2	TEST INSTRUMENTS	57
4.5.3	TEST PROCEDURE	57
4.5.4	DEVIATION FROM TEST STANDARD	57
4.5.5	TEST SETUP	58
4.5.6	EUT OPERATING CONDITION	58
4.5.7	TEST RESULTS	59
4.6	BAND EDGES MEASUREMENT	73
4.6.1	LIMITS OF BAND EDGES MEASUREMENT	73
4.6.2	TEST INSTRUMENTS	73
4.6.3	TEST PROCEDURE	74
4.6.4	DEVIATION FROM TEST STANDARD	74
4.6.5	EUT OPERATING CONDITION	75
4.6.6	TEST RESULTS	75
4.7	ANTENNA REQUIREMENT	91
4.7.1	STANDARD APPLICABLE	91
4.7.2	ANTENNA CONNECTED CONSTRUCTION.....	91
5.	PHOTOGRAPHS OF THE TEST CONFIGURATION	92
6.	INFORMATION ON THE TESTING LABORATORIES.....	93
7.	APPENDIX A - MODIFICATIONS RECORDERS FOR ENGINEERING CHANGES TO THE EUT BY THE LAB.....	94



1. CERTIFICATION

PRODUCT: Wireless -N USB 2.0 Adapter

MODEL: HWDN1 (refer to item 3.1 for more details)

BRAND: Hawking

APPLICANT: Hawking Technologies, Inc.

TESTED: Feb. 21 ~ Mar. 07, 2008

TEST SAMPLE: ENGINEERING SAMPLE

STANDARDS: FCC Part 15, Subpart C (Section 15.247)
ANSI C63.4-2003

The above equipment (model: HWDN1) has been tested by **Advance Data Technology Corporation**, and found compliance with the requirement of the above standards. The test record, data evaluation & Equipment Under Test (EUT) configurations represented herein are true and accurate accounts of the measurements of the sample's EMC characteristics under the conditions specified in this report.

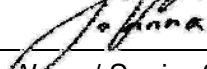
PREPARED BY :  , **DATE:** Mar. 10, 2008
Joanna Wang / Senior Specialist

TECHNICAL ACCEPTANCE :  , **DATE:** Mar. 10, 2008
Responsible for RF Long Chen / Senior Engineer

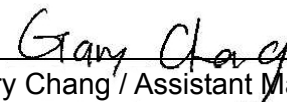
APPROVED BY :  , **DATE:** Mar. 10, 2008
Gary Chang / Assistant Manager

2. SUMMARY OF TEST RESULTS

The EUT has been tested according to the following specifications:

APPLIED STANDARD: FCC Part 15, Subpart C			
Standard Section	Test Type and Limit	Result	Remark
15.207	AC Power Conducted Emission	PASS	Meet the requirement of limit. Minimum passing margin is -13.51dB at 0.173MHz.
15.247(a)(2)	Spectrum Bandwidth of a Direct Sequence Spread Spectrum System Limit: min. 500kHz	PASS	Meet the requirement of limit.
15.247(b)	Maximum Peak Output Power Limit: max. 30dBm	PASS	Meet the requirement of limit.
15.247(d)	Radiated Emissions Limit: Table 15.209	PASS	Meet the requirement of limit. Minimum passing margin is -1.04dB at 4824.000MHz.
15.247(e)	Power Spectral Density Limit: max. 8dBm	PASS	Meet the requirement of limit.
15.247(d)	Band Edge Measurement Limit: 20dB less than the peak value of fundamental frequency	PASS	Meet the requirement of limit.

2.1 MEASUREMENT UNCERTAINTY

Where relevant, the following measurement uncertainty levels have been estimated for tests performed on the EUT as specified in CISPR 16-4-2:

MEASUREMENT	FREQUENCY	UNCERTAINTY
Conducted emissions	9kHz ~ 30MHz	2.44 dB
Radiated emissions	30MHz ~ 200MHz	3.34 dB
	200MHz ~ 1000MHz	3.35 dB
	1GHz ~ 18GHz	2.26 dB
	18GHz ~ 40GHz	1.94 dB

This uncertainty represents an expanded uncertainty expressed at approximately the 95% confidence level using a coverage factor of k=2.

3. GENERAL INFORMATION

3.1 GENERAL DESCRIPTION OF EUT

PRODUCT	Wireless -N USB 2.0 Adapter
MODEL NO.	HWDN1 (refer to NOTE for more details)
FCC ID	SOY-HWDN1
POWER SUPPLY	5Vdc from host equipment
MODULATION TYPE	CCK, DQPSK, DBPSK for DSSS 64QAM, 16QAM, QPSK, BPSK for OFDM
MODULATION TECHNOLOGY	DSSS, OFDM
TRANSFER RATE	802.11b: 11.0/ 5.5/ 2.0/ 1.0Mbps 802.11g: 54.0/ 48.0/ 36.0/ 24.0/ 18.0/ 12.0/ 9.0/ 6.0Mbps Draft 802.11n: up to 300.0Mbps
FREQUENCY RANGE	2412MHz ~ 2462MHz
NUMBER OF CHANNEL	11 for 802.11b, 802.11g, draft 802.11n (20MHz) 7 for draft 802.11n (40MHz)
MAXIMUM OUTPUT POWER	64.868mW
ANTENNA TYPE	Dish antenna with 5dBi gain
DATA CABLE	1.6m shielded USB cable without core
I/O PORTS	USB
ACCESSORY DEVICES	NA

NOTE:

1. The models as identified below are identical to each other except of the following options:

BRAND	MODEL	DESCRIPTION
Hawking	HWDN1 / A	With Mac driver
Hawking	HWDN1	With Windows driver

2. The EUT incorporates a MIMO function. Physically, the EUT provides two completed transmitters and two receivers.

	1TX	2TX
802.11b	√	-
802.11g	-	√
Draft 802.11n (20MHz)	-	√
Draft 802.11n (40MHz)	-	√

3. The above EUT information was declared by manufacturer and for more detailed features description, please refer to the manufacturer's specifications or user's manual.

3.2 DESCRIPTION OF TEST MODES

Eleven channels are provided for 802.11b, 802.11g and draft 802.11n (20MHz):

CHANNEL	FREQUENCY	CHANNEL	FREQUENCY
1	2412MHz	7	2442MHz
2	2417MHz	8	2447MHz
3	2422MHz	9	2452MHz
4	2427MHz	10	2457MHz
5	2432MHz	11	2462MHz
6	2437MHz		

Seven channels are provided for draft 802.11n (40MHz):

CHANNEL	FREQUENCY	CHANNEL	FREQUENCY
1	2422MHz	5	2442MHz
2	2427MHz	6	2447MHz
3	2432MHz	7	2452MHz
4	2437MHz		

3.2.1 CONFIGURATION OF SYSTEM UNDER TEST

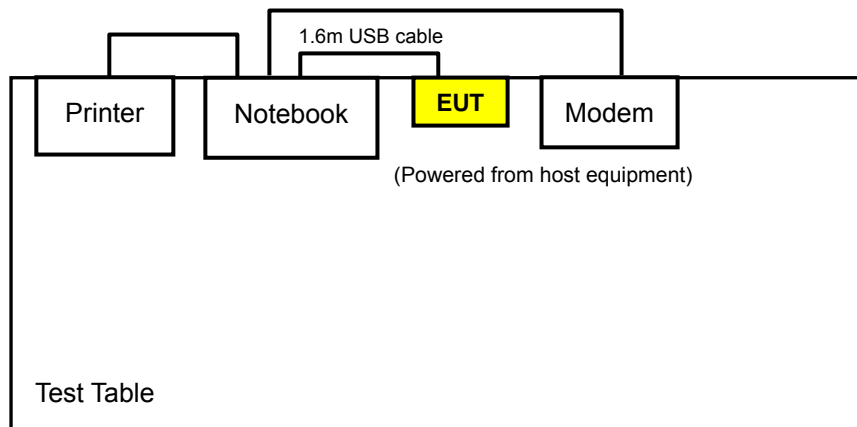

3.2.2 TEST MODE APPLICABILITY AND TESTED CHANNEL DETAIL

EUT Configure Mode	Applicable to				Description
	RE \geq 1G	RE<1G	PLC	APCM	
-	√	√	√	√	-

Where **PLC**: Power Line Conducted Emission **RE<1G**: Radiated Emission below 1GHz
RE \geq 1G: Radiated Emission above 1GHz **APCM**: Antenna Port Conducted Measurement

RADIATED EMISSION TEST (ABOVE 1 GHz):

- Pre-Scan has been conducted to determine the worst-case mode from all possible combinations between available modulations, data rates, and antenna ports (if EUT with antenna diversity architecture).
- Following channel(s) was (were) selected for the final test as listed below.

Mode	Available Channel	Tested Channel	Modulation Technology	Modulation Type	Data Rate (Mbps)
802.11b	1 to 11	1, 6, 11	DSSS	DBPSK	1
802.11g	1 to 11	1, 6, 11	OFDM	BPSK	6
Draft 802.11n (20MHz)	1 to 11	1, 6, 11	OFDM	BPSK	7.2
Draft 802.11n (40MHz)	1 to 7	1, 4, 7	OFDM	BPSK	15

RADIATED EMISSION TEST (BELOW 1 GHz):

- Pre-Scan has been conducted to determine the worst-case mode from all possible combinations between available modulations, data rates, and antenna ports (if EUT with antenna diversity architecture).
- Following channel(s) was (were) selected for the final test as listed below.

Mode	Available Channel	Tested Channel	Modulation Technology	Modulation Type	Data Rate (Mbps)
Draft 802.11n (20MHz)	1 to 11	1	OFDM	BPSK	7.2

POWER LINE CONDUCTED EMISSION TEST:

- Pre-Scan has been conducted to determine the worst-case mode from all possible combinations between available modulations, data rates, and antenna ports (if EUT with antenna diversity architecture).
- Following channel(s) was (were) selected for the final test as listed below.

Mode	Available Channel	Tested Channel	Modulation Technology	Modulation Type	Data Rate (Mbps)
Draft 802.11n (20MHz)	1 to 11	1	OFDM	BPSK	7.2

BANDEDGE MEASUREMENT:

- Pre-Scan has been conducted to determine the worst-case mode from all possible combinations between available modulations, data rates, and antenna ports (if EUT with antenna diversity architecture).
- Following channel(s) was (were) selected for the final test as listed below.

Mode	Available Channel	Tested Channel	Modulation Technology	Modulation Type	Data Rate (Mbps)
802.11b	1 to 11	1, 11	DSSS	DBPSK	1
802.11g	1 to 11	1, 11	OFDM	BPSK	6
Draft 802.11n (20MHz)	1 to 11	1, 11	OFDM	BPSK	7.2
Draft 802.11n (40MHz)	1 to 7	1, 7	OFDM	BPSK	15

ANTENNA PORT CONDUCTED MEASUREMENT:

- Pre-Scan has been conducted to determine the worst-case mode from all possible combinations between available modulations, data rates, and antenna ports (if EUT with antenna diversity architecture).
- Following channel(s) was (were) selected for the final test as listed below.

Mode	Available Channel	Tested Channel	Modulation Technology	Modulation Type	Data Rate (Mbps)
802.11b	1 to 11	1, 6, 11	DSSS	DBPSK	1
802.11g	1 to 11	1, 6, 11	OFDM	BPSK	6
Draft 802.11n (20MHz)	1 to 11	1, 6, 11	OFDM	BPSK	7.2
Draft 802.11n (40MHz)	1 to 7	1, 4, 7	OFDM	BPSK	15



3.3 GENERAL DESCRIPTION OF APPLIED STANDARDS

The EUT is a RF product. According to the specifications of the manufacturer, it must comply with the requirements of the following standards:

FCC Part 15, Subpart C (15.247)

ANSI C63.4-2003

All test items have been performed and recorded as per the above standards.

NOTE: The EUT is also considered as a kind of computer peripheral, because the connection to computer is necessary for typical use. It has been verified to comply with the requirements of FCC Part 15, Subpart B, Class B (DoC). The test report has been issued separately.

3.4 DESCRIPTION OF SUPPORT UNITS

The EUT has been tested as an independent unit together with other necessary accessories or support units. The following support units or accessories were used to form a representative test configuration during the tests.

NO.	PRODUCT	BRAND	MODEL NO.	SERIAL NO.	FCC ID
1	NOTEBOOK COMPUTER	DELL	PP05L	9954115984	E2K24CLNS
2	PRINTER	EPSON	LQ-300+	DCGY047265	FCC DoC Approved
3	MODEM	ACEEX	1414V/3	0401008269	IFAXDM1414

NO.	SIGNAL CABLE DESCRIPTION OF THE ABOVE SUPPORT UNITS
1	NA
2	1.8m braid shielded wire, DB25 connector, w/o core.
3	1.2m braid shielded wire, DB25 & DB9 connector, w/o core.

NOTE: All power cords of the above support units are non shielded (1.8m).

4. TEST TYPES AND RESULTS

4.1 RADIATED EMISSION MEASUREMENT

4.1.1 LIMITS OF RADIATED EMISSION MEASUREMENT

Emissions radiated outside of the specified bands, shall be according to the general radiated limits in 15.209 as following:

FREQUENCIES (MHz)	FIELD STRENGTH (microvolts/meter)	MEASUREMENT DISTANCE (meters)
0.009 ~ 0.490	2400 / F(kHz)	300
0.490 ~ 1.705	24000 / F(kHz)	30
1.705 ~ 30.0	30	30
30 ~ 88	100	3
88 ~ 216	150	3
216 ~ 960	200	3
Above 960	500	3

NOTE:

1. The lower limit shall apply at the transition frequencies.
2. Emission level (dBuV/m) = 20 log Emission level (uV/m).
3. As shown in 15.35(b), for frequencies above 1000MHz, the field strength limits are based on average detector, however, the peak field strength of any emission shall not exceed the maximum permitted average limits, specified above by more than 20dB under any condition of modulation.



4.1.2 TEST INSTRUMENTS

DESCRIPTION & MANUFACTURER	MODEL NO.	SERIAL NO.	CALIBRATED UNTIL
Test Receiver ROHDE & SCHWARZ	ESCI	100424	Jul. 27, 2008
Spectrum Analyzer ROHDE & SCHWARZ	FSP40	100041	Feb. 26, 2009
BILOG Antenna SCHWARZBECK	VULB9168	9168-160	May 31, 2008
HORN Antenna SCHWARZBECK	9120D	9120D-209	Jun. 28, 2008
HORN Antenna SCHWARZBECK	BBHA 9170	BBHA9170243	Dec. 24, 2008
Preamplifier Agilent	8447D	2944A10633	Oct. 28, 2008
Preamplifier Agilent	8449B	3008A01964	Oct. 23, 2008
RF signal cable HUBER+SUHNNER	SUCOFLEX 104	283402/4	Dec. 06, 2008
RF signal cable HUBER+SUHNNER	SUCOFLEX 104	251644/4	Dec. 06, 2008
Software ADT.	ADT_Radiated_V7.6	NA	NA
Antenna Tower inn-co GmbH	MA 4000	013303	NA
Antenna Tower Controller inn-co GmbH	CO2000	017303	NA
Turn Table ADT.	TT100.	TT93021703	NA
Turn Table Controller ADT.	SC100.	SC93021703	NA

- NOTE:**
1. The calibration interval of the above test instruments is 12 months and the calibrations are traceable to NML/ROC and NIST/USA.
 2. The test was performed in HwaYa Chamber 3.
 3. The horn antenna and HP preamplifier (model: 8449B) are used only for the measurement of emission frequency above 1GHz if tested.
 4. The VCCI Site Registration No. is R-237.
 5. The IC Site Registration No. is IC3789B-3.

4.1.3 TEST PROCEDURES

- a. The EUT was placed on the top of a rotating table 0.8 meters above the ground at a 3 meters semi-anechoic chamber. The table was rotated 360 degrees to determine the position of the highest radiation.
- b. The EUT was set 3 meters away from the interference-receiving antenna, which was mounted on the top of a variable-height antenna tower.
- c. The antenna is a broadband antenna, and its height is varied from one meter to four meters above the ground to determine the maximum value of the field strength. Both horizontal and vertical polarizations of the antenna are set to make the measurement.
- d. For each suspected emission, the EUT was arranged to its worst case and then the antenna was tuned to heights from 1 meter to 4 meters and the rotatable table was turned from 0 degrees to 360 degrees to find the maximum reading.
- e. The test-receiver system was set to Peak Detect Function and Specified Bandwidth with Maximum Hold Mode.
- f. If the emission level of the EUT in peak mode was lower than the limit specified, then testing could be stopped and the peak values of the EUT would be reported. Otherwise the emissions would be re-tested one by one using peak, quasi-peak or average method as specified and then reported in a data sheet.

NOTE:

1. The resolution bandwidth and video bandwidth of test receiver/spectrum analyzer is 120kHz for Peak detection (PK) and Quasi-peak detection (QP) at frequency below 1GHz.
2. The resolution bandwidth of test receiver/spectrum analyzer is 1 MHz and video bandwidth is 3MHz for Peak detection at frequency above 1GHz.
3. The resolution bandwidth of test receiver/spectrum analyzer is 1MHz and the video bandwidth is 10Hz for Average detection (AV) at frequency above 1GHz.
4. All modes of operation were investigated and the worst-case emissions are reported.

4.1.4 DEVIATION FROM TEST STANDARD

No deviation.

4.1.5 TEST SETUP

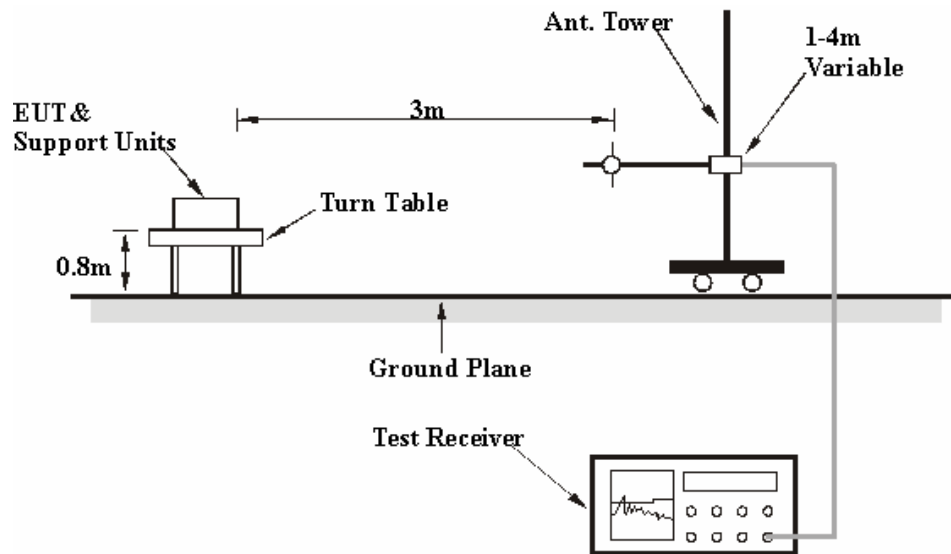

For the actual test configuration, please refer to the attached file (Test Setup Photo)

4.1.6 EUT OPERATING CONDITIONS

- a. Connected the EUT to notebook (via USB cable) and placed on a testing table.
- b. The notebook ran a test program (provided by manufacturer) to enable EUT under transmission condition continuously at specific channel frequency.
- c. The necessary accessories enable the system in full functions.

4.1.7 TEST RESULTS

802.11b DSSS MODULATION

EUT TEST CONDITION		MEASUREMENT DETAIL	
CHANNEL	Channel 1	FREQUENCY RANGE	1 ~ 25GHz
INPUT POWER (SYSTEM)	120Vac, 60 Hz	DETECTOR FUNCTION	Peak (PK) Average (AV)
ENVIRONMENTAL CONDITIONS	23deg. C, 70%RH 1016hPa	TESTED BY	Lori Chiu

ANTENNA POLARITY & TEST DISTANCE: HORIZONTAL AT 3 M								
NO.	FREQ. (MHz)	EMISSION LEVEL (dBuV/m)	LIMIT (dBuV/m)	MARGIN (dB)	ANTENNA HEIGHT (m)	TABLE ANGLE (Degree)	RAW VALUE (dBuV)	CORRECTION FACTOR (dB/m)
1	2386.00	63.07 PK	74.00	-10.93	1.00 H	173	30.75	32.32
2	2386.00	52.90 AV	54.00	-1.10	1.00 H	173	20.58	32.32
3	*2412.00	104.51 PK			1.00 H	100	72.19	32.32
4	*2412.00	100.08 AV			1.00 H	100	67.76	32.32
5	3216.00	48.10 PK	84.51	-36.41	1.00 H	127	14.53	33.57
6	3216.00	42.15 AV	80.08	-37.93	1.00 H	127	8.58	33.57
7	4824.00	53.05 PK	74.00	-20.95	1.00 H	202	15.05	38.00
8	4824.00	49.13 AV	54.00	-4.87	1.00 H	202	11.13	38.00
ANTENNA POLARITY & TEST DISTANCE: VERTICAL AT 3 M								
NO.	FREQ. (MHz)	EMISSION LEVEL (dBuV/m)	LIMIT (dBuV/m)	MARGIN (dB)	ANTENNA HEIGHT (m)	TABLE ANGLE (Degree)	RAW VALUE (dBuV)	CORRECTION FACTOR (dB/m)
1	2386.00	57.41 PK	74.00	-16.59	1.54 V	156	25.09	32.32
2	2386.00	46.94 AV	54.00	-7.06	1.54 V	156	14.62	32.32
3	*2412.00	95.00 PK			1.54 V	156	62.68	32.32
4	*2412.00	90.48 AV			1.54 V	156	58.16	32.32
5	3216.00	49.81 PK	75.00	-25.19	1.00 V	255	16.24	33.57
6	3216.00	45.89 AV	70.48	-24.59	1.00 V	255	12.32	33.57
7	4824.00	55.42 PK	74.00	-18.58	1.00 V	1	17.42	38.00
8	4824.00	52.96 AV	54.00	-1.04	1.00 V	1	14.96	38.00

- REMARKS:**
1. Emission level (dBuV/m) = Raw Value (dBuV) + Correction Factor (dB/m).
 2. Correction Factor (dB/m) = Antenna Factor (dB/m) + Cable Factor (dB).
 3. The other emission levels were very low against the limit.
 4. Margin value = Emission level – Limit value.
 5. “ * “: Fundamental frequency.



EUT TEST CONDITION		MEASUREMENT DETAIL	
CHANNEL	Channel 6	FREQUENCY RANGE	1 ~ 25GHz
INPUT POWER (SYSTEM)	120Vac, 60 Hz	DETECTOR FUNCTION	Peak (PK) Average (AV)
ENVIRONMENTAL CONDITIONS	23deg. C, 70%RH 1016hPa	TESTED BY	Lori Chiu

ANTENNA POLARITY & TEST DISTANCE: HORIZONTAL AT 3 M								
NO.	FREQ. (MHz)	EMISSION LEVEL (dBuV/m)	LIMIT (dBuV/m)	MARGIN (dB)	ANTENNA HEIGHT (m)	TABLE ANGLE (Degree)	RAW VALUE (dBuV)	CORRECTION FACTOR (dB/m)
1	*2437.00	106.21 PK			1.00 H	187	73.87	32.34
2	*2437.00	101.88 AV			1.00 H	187	69.54	32.34
3	4874.00	52.13 PK	74.00	-21.87	1.00 H	336	14.01	38.12
4	4874.00	47.97 AV	54.00	-6.03	1.00 H	336	9.85	38.12
ANTENNA POLARITY & TEST DISTANCE: VERTICAL AT 3 M								
NO.	FREQ. (MHz)	EMISSION LEVEL (dBuV/m)	LIMIT (dBuV/m)	MARGIN (dB)	ANTENNA HEIGHT (m)	TABLE ANGLE (Degree)	RAW VALUE (dBuV)	CORRECTION FACTOR (dB/m)
1	*2437.00	97.17 PK			1.05 V	228	64.83	32.34
2	*2437.00	92.87 AV			1.05 V	228	60.53	32.34
3	3249.00	47.76 PK	77.17	-29.41	1.55 V	273	14.31	33.45
4	3249.00	42.59 AV	72.87	-30.28	1.55 V	273	9.14	33.45
5	4874.00	55.67 PK	74.00	-18.33	1.08 V	10	17.55	38.12
6	4874.00	52.64 AV	54.00	-1.36	1.08 V	10	14.52	38.12

- REMARKS:**
1. Emission level (dBuV/m) = Raw Value (dBuV) + Correction Factor (dB/m).
 2. Correction Factor (dB/m) = Antenna Factor (dB/m) + Cable Factor (dB).
 3. The other emission levels were very low against the limit.
 4. Margin value = Emission level – Limit value.
 5. “ * “: Fundamental frequency.

EUT TEST CONDITION		MEASUREMENT DETAIL	
CHANNEL	Channel 11	FREQUENCY RANGE	1 ~ 25GHz
INPUT POWER (SYSTEM)	120Vac, 60 Hz	DETECTOR FUNCTION	Peak (PK) Average (AV)
ENVIRONMENTAL CONDITIONS	23deg. C, 70%RH 1016hPa	TESTED BY	Lori Chiu

ANTENNA POLARITY & TEST DISTANCE: HORIZONTAL AT 3 M								
NO.	FREQ. (MHz)	EMISSION LEVEL (dBuV/m)	LIMIT (dBuV/m)	MARGIN (dB)	ANTENNA HEIGHT (m)	TABLE ANGLE (Degree)	RAW VALUE (dBuV)	CORRECTION FACTOR (dB/m)
1	*2462.00	106.34 PK			1.00 H	175	73.97	32.37
2	*2462.00	101.88 AV			1.00 H	175	69.51	32.37
3	2487.00	60.71 PK	74.00	-13.29	1.00 H	188	28.32	32.39
4	2487.00	49.84 AV	54.00	-4.16	1.00 H	188	17.45	32.39
5	4924.00	50.33 PK	74.00	-23.67	1.00 H	210	12.10	38.23
6	4924.00	44.01 AV	54.00	-9.99	1.00 H	210	5.78	38.23
ANTENNA POLARITY & TEST DISTANCE: VERTICAL AT 3 M								
NO.	FREQ. (MHz)	EMISSION LEVEL (dBuV/m)	LIMIT (dBuV/m)	MARGIN (dB)	ANTENNA HEIGHT (m)	TABLE ANGLE (Degree)	RAW VALUE (dBuV)	CORRECTION FACTOR (dB/m)
1	*2462.00	98.48 PK			1.05 V	237	66.11	32.37
2	*2462.00	93.99 AV			1.05 V	237	61.62	32.37
3	2487.00	58.16 PK	74.00	-15.84	1.05 V	237	25.77	32.39
4	2487.00	47.48 AV	54.00	-6.52	1.05 V	237	15.09	32.39
5	3282.00	47.12 PK	78.48	-31.36	1.09 V	270	13.78	33.34
6	3282.00	40.43 AV	73.99	-33.56	1.09 V	270	7.09	33.34
7	4924.00	52.98 PK	74.00	-21.02	1.06 V	19	14.75	38.23
8	4924.00	49.19 AV	54.00	-4.81	1.06 V	19	10.96	38.23

- REMARKS:**
1. Emission level (dBuV/m) = Raw Value (dBuV) + Correction Factor (dB/m).
 2. Correction Factor (dB/m) = Antenna Factor (dB/m) + Cable Factor (dB).
 3. The other emission levels were very low against the limit.
 4. Margin value = Emission level – Limit value.
 5. “ * “: Fundamental frequency.



802.11g OFDM MODULATION

EUT TEST CONDITION		MEASUREMENT DETAIL	
CHANNEL	Channel 1	FREQUENCY RANGE	1 ~ 25GHz
INPUT POWER (SYSTEM)	120Vac, 60 Hz	DETECTOR FUNCTION	Peak (PK) Average (AV)
ENVIRONMENTAL CONDITIONS	23deg. C, 70%RH 1016hPa	TESTED BY	Lori Chiu

ANTENNA POLARITY & TEST DISTANCE: HORIZONTAL AT 3 M								
NO.	FREQ. (MHz)	EMISSION LEVEL (dBuV/m)	LIMIT (dBuV/m)	MARGIN (dB)	ANTENNA HEIGHT (m)	TABLE ANGLE (Degree)	RAW VALUE (dBuV)	CORRECTION FACTOR (dB/m)
1	2390.00	35.17 PK	74.00	-38.83	1.00 H	203	2.85	32.32
2	2390.00	48.16 AV	54.00	-5.84	1.00 H	203	15.84	32.32
3	*2412.00	104.51 PK			1.00 H	203	72.19	32.32
4	*2412.00	94.45 AV			1.00 H	203	62.13	32.32
5	4824.00	53.96 PK	74.00	-20.04	1.24 H	345	15.96	38.00
6	4824.00	40.17 AV	54.00	-13.83	1.24 H	345	2.17	38.00
ANTENNA POLARITY & TEST DISTANCE: VERTICAL AT 3 M								
NO.	FREQ. (MHz)	EMISSION LEVEL (dBuV/m)	LIMIT (dBuV/m)	MARGIN (dB)	ANTENNA HEIGHT (m)	TABLE ANGLE (Degree)	RAW VALUE (dBuV)	CORRECTION FACTOR (dB/m)
1	2390.00	65.02 PK	74.00	-8.98	1.12 V	202	32.70	32.32
2	2390.00	50.33 AV	54.00	-3.67	1.12 V	202	18.01	32.32
3	*2412.00	105.52 PK			1.12 V	205	73.20	32.32
4	*2412.00	95.66 AV			1.12 V	205	63.34	32.32
5	3216.00	48.49 PK	85.52	-37.03	1.29 V	26	14.92	33.57
6	3216.00	43.13 AV	75.66	-32.53	1.29 V	26	9.56	33.57
7	4824.00	58.44 PK	74.00	-15.56	1.08 V	50	20.44	38.00
8	4824.00	45.54 AV	54.00	-8.46	1.08 V	50	7.54	38.00

- REMARKS:**
1. Emission level (dBuV/m) = Raw Value (dBuV) + Correction Factor (dB/m).
 2. Correction Factor (dB/m) = Antenna Factor (dB/m) + Cable Factor (dB).
 3. The other emission levels were very low against the limit.
 4. Margin value = Emission level – Limit value.
 5. “ * “: Fundamental frequency.



EUT TEST CONDITION		MEASUREMENT DETAIL	
CHANNEL	Channel 6	FREQUENCY RANGE	1 ~ 25GHz
INPUT POWER (SYSTEM)	120Vac, 60 Hz	DETECTOR FUNCTION	Peak (PK) Average (AV)
ENVIRONMENTAL CONDITIONS	23deg. C, 70%RH 1016hPa	TESTED BY	Lori Chiu

ANTENNA POLARITY & TEST DISTANCE: HORIZONTAL AT 3 M								
NO.	FREQ. (MHz)	EMISSION LEVEL (dBuV/m)	LIMIT (dBuV/m)	MARGIN (dB)	ANTENNA HEIGHT (m)	TABLE ANGLE (Degree)	RAW VALUE (dBuV)	CORRECTION FACTOR (dB/m)
1	*2437.00	103.95 PK			1.00 H	204	71.61	32.34
2	*2437.00	93.12 AV			1.00 H	204	60.78	32.34
3	4874.00	56.57 PK	74.00	-17.43	1.00 H	246	18.45	38.12
4	4874.00	43.08 AV	54.00	-10.92	1.00 H	246	4.96	38.12
ANTENNA POLARITY & TEST DISTANCE: VERTICAL AT 3 M								
NO.	FREQ. (MHz)	EMISSION LEVEL (dBuV/m)	LIMIT (dBuV/m)	MARGIN (dB)	ANTENNA HEIGHT (m)	TABLE ANGLE (Degree)	RAW VALUE (dBuV)	CORRECTION FACTOR (dB/m)
1	*2437.00	105.02 PK			1.08 V	219	72.68	32.34
2	*2437.00	95.16 AV			1.08 V	219	62.82	32.34
3	3249.00	47.58 PK	85.02	-37.44	1.00 V	155	14.13	33.45
4	3249.00	42.08 AV	75.16	-33.08	1.00 V	155	8.63	33.45
5	4874.00	58.24 PK	74.00	-15.76	1.00 V	137	20.12	38.12
6	4874.00	45.38 AV	54.00	-8.62	1.00 V	137	7.26	38.12

- REMARKS:**
1. Emission level (dBuV/m) = Raw Value (dBuV) + Correction Factor (dB/m).
 2. Correction Factor (dB/m) = Antenna Factor (dB/m) + Cable Factor (dB).
 3. The other emission levels were very low against the limit.
 4. Margin value = Emission level – Limit value.
 5. “ * “: Fundamental frequency.

EUT TEST CONDITION		MEASUREMENT DETAIL	
CHANNEL	Channel 11	FREQUENCY RANGE	1 ~ 25GHz
INPUT POWER (SYSTEM)	120Vac, 60 Hz	DETECTOR FUNCTION	Peak (PK) Average (AV)
ENVIRONMENTAL CONDITIONS	23deg. C, 70%RH 1016hPa	TESTED BY	Lori Chiu

ANTENNA POLARITY & TEST DISTANCE: HORIZONTAL AT 3 M								
NO.	FREQ. (MHz)	EMISSION LEVEL (dBuV/m)	LIMIT (dBuV/m)	MARGIN (dB)	ANTENNA HEIGHT (m)	TABLE ANGLE (Degree)	RAW VALUE (dBuV)	CORRECTION FACTOR (dB/m)
1	*2462.00	103.54 PK			1.00 H	200	71.17	32.37
2	*2462.00	93.38 AV			1.00 H	200	61.01	32.37
3	2483.50	63.43 PK	74.00	-10.57	1.00 H	176	31.04	32.39
4	2483.50	49.31 AV	54.00	-4.69	1.00 H	176	16.92	32.39
5	4924.00	53.94 PK	74.00	-20.06	1.00 H	216	15.71	38.23
6	4924.00	39.90 AV	54.00	-14.10	1.00 H	216	1.67	38.23
ANTENNA POLARITY & TEST DISTANCE: VERTICAL AT 3 M								
NO.	FREQ. (MHz)	EMISSION LEVEL (dBuV/m)	LIMIT (dBuV/m)	MARGIN (dB)	ANTENNA HEIGHT (m)	TABLE ANGLE (Degree)	RAW VALUE (dBuV)	CORRECTION FACTOR (dB/m)
1	*2462.00	105.42 PK			1.07 V	220	73.05	32.37
2	*2462.00	95.36 AV			1.07 V	220	62.99	32.37
3	2483.50	64.69 PK	74.00	-9.31	1.06 V	227	32.30	32.39
4	2483.50	49.37 AV	54.00	-4.63	1.06 V	227	16.98	32.39
5	3282.00	48.92 PK	85.42	-36.50	1.00 V	131	15.58	33.34
6	3282.00	44.38 AV	75.36	-30.98	1.00 V	131	11.04	33.34
7	4924.00	54.00 PK	74.00	-20.00	1.08 V	360	15.77	38.23
8	4924.00	40.65 AV	54.00	-13.35	1.08 V	360	2.42	38.23

- REMARKS:**
1. Emission level (dBuV/m) = Raw Value (dBuV) + Correction Factor (dB/m).
 2. Correction Factor (dB/m) = Antenna Factor (dB/m) + Cable Factor (dB).
 3. The other emission levels were very low against the limit.
 4. Margin value = Emission level – Limit value.
 5. “ * “: Fundamental frequency.

DRAFT 802.11n (20MHz) OFDM MODULATION

EUT TEST CONDITION		MEASUREMENT DETAIL	
CHANNEL	Channel 1	FREQUENCY RANGE	1 ~ 25GHz
INPUT POWER (SYSTEM)	120Vac, 60 Hz	DETECTOR FUNCTION	Peak (PK) Average (AV)
ENVIRONMENTAL CONDITIONS	25deg. C, 66%RH 1016hPa	TESTED BY	Dean Wang

ANTENNA POLARITY & TEST DISTANCE: HORIZONTAL AT 3 M								
NO.	FREQ. (MHz)	EMISSION LEVEL (dBuV/m)	LIMIT (dBuV/m)	MARGIN (dB)	ANTENNA HEIGHT (m)	TABLE ANGLE (Degree)	RAW VALUE (dBuV)	CORRECTION FACTOR (dB/m)
1	2390.00	61.34 PK	74.00	-12.66	1.10 H	355	29.10	32.24
2	2390.00	50.89 AV	54.00	-3.11	1.10 H	355	18.65	32.24
3	*2412.00	104.46 PK			1.10 H	355	72.14	32.32
4	*2412.00	94.16 AV			1.10 H	355	61.84	32.32
5	3216.00	51.82 PK	84.46	-32.64	1.03 H	348	17.34	34.49
6	3216.00	47.04 AV	74.16	-27.12	1.03 H	348	12.56	34.49
7	4824.00	52.79 PK	74.00	-21.21	1.03 H	8	14.66	38.13
8	4824.00	38.29 AV	54.00	-15.71	1.03 H	8	0.16	38.13
9	6432.00	58.77 PK	84.46	-25.69	1.00 H	40	17.24	41.53
10	6432.00	55.99 AV	74.16	-18.17	1.00 H	40	14.46	41.53

- REMARKS:**
1. Emission level (dBuV/m) = Raw Value (dBuV) + Correction Factor (dB/m).
 2. Correction Factor (dB/m) = Antenna Factor (dB/m) + Cable Factor (dB).
 3. The other emission levels were very low against the limit.
 4. Margin value = Emission level – Limit value.
 5. “ * “: Fundamental frequency.



EUT TEST CONDITION		MEASUREMENT DETAIL	
CHANNEL	Channel 1	FREQUENCY RANGE	1 ~ 25GHz
INPUT POWER (SYSTEM)	120Vac, 60 Hz	DETECTOR FUNCTION	Peak (PK) Average (AV)
ENVIRONMENTAL CONDITIONS	25deg. C, 66%RH 1016hPa	TESTED BY	Dean Wang

ANTENNA POLARITY & TEST DISTANCE: VERTICAL AT 3 M								
NO.	FREQ. (MHz)	EMISSION LEVEL (dBuV/m)	LIMIT (dBuV/m)	MARGIN (dB)	ANTENNA HEIGHT (m)	TABLE ANGLE (Degree)	RAW VALUE (dBuV)	CORRECTION FACTOR (dB/m)
1	2390.00	63.89 PK	74.00	-10.11	1.00 V	9	31.65	32.24
2	2390.00	48.07 AV	54.00	-5.93	1.00 V	9	15.83	32.24
3	*2412.00	102.13 PK			1.00 V	9	69.81	32.32
4	*2412.00	92.11 AV			1.00 V	9	59.79	32.32
5	3216.00	50.47 PK	82.13	-31.66	1.02 V	11	15.99	34.49
6	3216.00	43.14 AV	72.11	-28.97	1.02 V	11	8.66	34.49
7	4824.00	55.12 PK	74.00	-18.88	1.00 V	42	16.99	38.13
8	4824.00	40.15 AV	54.00	-13.85	1.00 V	42	2.02	38.13
9	6432.00	57.27 PK	82.13	-24.86	1.00 V	33	15.74	41.53
10	6432.00	53.85 AV	72.11	-18.26	1.00 V	33	12.32	41.53

- REMARKS:**
1. Emission level (dBuV/m) = Raw Value (dBuV) + Correction Factor (dB/m).
 2. Correction Factor (dB/m) = Antenna Factor (dB/m) + Cable Factor (dB).
 3. The other emission levels were very low against the limit.
 4. Margin value = Emission level – Limit value.
 5. “ * “: Fundamental frequency.



EUT TEST CONDITION		MEASUREMENT DETAIL	
CHANNEL	Channel 6	FREQUENCY RANGE	1 ~ 25GHz
INPUT POWER (SYSTEM)	120Vac, 60 Hz	DETECTOR FUNCTION	Peak (PK) Average (AV)
ENVIRONMENTAL CONDITIONS	25deg. C, 66%RH 1016hPa	TESTED BY	Dean Wang

ANTENNA POLARITY & TEST DISTANCE: HORIZONTAL AT 3 M								
NO.	FREQ. (MHz)	EMISSION LEVEL (dBuV/m)	LIMIT (dBuV/m)	MARGIN (dB)	ANTENNA HEIGHT (m)	TABLE ANGLE (Degree)	RAW VALUE (dBuV)	CORRECTION FACTOR (dB/m)
1	*2437.00	104.48 PK			1.07 H	3	72.08	32.40
2	*2437.00	94.12 AV			1.07 H	3	61.72	32.40
3	3250.00	50.73 PK	84.48	-33.75	1.00 H	8	16.22	34.51
4	3250.00	45.54 AV	74.12	-28.58	1.00 H	8	11.03	34.51
5	4874.00	53.73 PK	74.00	-20.27	1.03 H	17	15.41	38.32
6	4874.00	39.29 AV	54.00	-14.71	1.03 H	17	0.97	38.32
7	6498.00	56.75 PK	84.48	-27.73	1.03 H	32	15.05	41.70
8	6498.00	52.98 AV	74.12	-21.14	1.03 H	32	11.28	41.70

ANTENNA POLARITY & TEST DISTANCE: VERTICAL AT 3 M								
NO.	FREQ. (MHz)	EMISSION LEVEL (dBuV/m)	LIMIT (dBuV/m)	MARGIN (dB)	ANTENNA HEIGHT (m)	TABLE ANGLE (Degree)	RAW VALUE (dBuV)	CORRECTION FACTOR (dB/m)
1	*2437.00	102.05 PK			1.00 V	10	69.65	32.40
2	*2437.00	92.04 AV			1.00 V	10	59.64	32.40
3	3250.00	49.61 PK	82.05	-32.44	1.02 V	13	15.10	34.51
4	3250.00	42.48 AV	72.04	-29.56	1.02 V	13	7.97	34.51
5	4874.00	55.96 PK	74.00	-18.04	1.00 V	36	17.64	38.32
6	4874.00	41.45 AV	54.00	-12.55	1.00 V	36	3.13	38.32
7	6498.00	55.58 PK	82.05	-26.47	1.00 V	61	13.88	41.70
8	6498.00	51.82 AV	72.04	-20.22	1.00 V	61	10.12	41.70

- REMARKS:**
1. Emission level (dBuV/m) = Raw Value (dBuV) + Correction Factor (dB/m).
 2. Correction Factor (dB/m) = Antenna Factor (dB/m) + Cable Factor (dB).
 3. The other emission levels were very low against the limit.
 4. Margin value = Emission level – Limit value.
 5. “ * “: Fundamental frequency.



EUT TEST CONDITION		MEASUREMENT DETAIL	
CHANNEL	Channel 11	FREQUENCY RANGE	1 ~ 25GHz
INPUT POWER (SYSTEM)	120Vac, 60 Hz	DETECTOR FUNCTION	Peak (PK) Average (AV)
ENVIRONMENTAL CONDITIONS	25deg. C, 66%RH 1016hPa	TESTED BY	Dean Wang

ANTENNA POLARITY & TEST DISTANCE: HORIZONTAL AT 3 M								
NO.	FREQ. (MHz)	EMISSION LEVEL (dBuV/m)	LIMIT (dBuV/m)	MARGIN (dB)	ANTENNA HEIGHT (m)	TABLE ANGLE (Degree)	RAW VALUE (dBuV)	CORRECTION FACTOR (dB/m)
1	*2462.00	105.06 PK			1.06 H	2	72.58	32.48
2	*2462.00	94.94 AV			1.06 H	2	62.46	32.48
3	2483.50	67.83 PK	74.00	-6.17	1.06 H	2	35.27	32.56
4	2483.50	50.04 AV	54.00	-3.96	1.06 H	2	17.48	32.56
5	3282.00	50.01 PK	85.06	-35.05	1.00 H	8	15.49	34.52
6	3282.00	44.14 AV	74.94	-30.80	1.00 H	8	9.62	34.52
7	4924.00	53.39 PK	74.00	-20.61	1.03 H	11	14.93	38.46
8	4924.00	38.73 AV	54.00	-15.27	1.03 H	11	0.27	38.46
9	6565.00	56.90 PK	85.06	-28.16	1.06 H	36	14.88	42.02
10	6565.00	51.69 AV	74.94	-23.25	1.06 H	36	9.67	42.02

- REMARKS:**
1. Emission level (dBuV/m) = Raw Value (dBuV) + Correction Factor (dB/m).
 2. Correction Factor (dB/m) = Antenna Factor (dB/m) + Cable Factor (dB).
 3. The other emission levels were very low against the limit.
 4. Margin value = Emission level – Limit value.
 5. “ * “: Fundamental frequency.



EUT TEST CONDITION		MEASUREMENT DETAIL	
CHANNEL	Channel 11	FREQUENCY RANGE	1 ~ 25GHz
INPUT POWER (SYSTEM)	120Vac, 60 Hz	DETECTOR FUNCTION	Peak (PK) Average (AV)
ENVIRONMENTAL CONDITIONS	25deg. C, 66%RH 1016hPa	TESTED BY	Dean Wang

ANTENNA POLARITY & TEST DISTANCE: VERTICAL AT 3 M								
NO.	FREQ. (MHz)	EMISSION LEVEL (dBuV/m)	LIMIT (dBuV/m)	MARGIN (dB)	ANTENNA HEIGHT (m)	TABLE ANGLE (Degree)	RAW VALUE (dBuV)	CORRECTION FACTOR (dB/m)
1	*2462.00	102.82 PK			1.00 V	11	70.34	32.48
2	*2462.00	92.76 AV			1.00 V	11	60.28	32.48
3	2483.50	65.76 PK	74.00	-8.24	1.00 V	11	33.20	32.56
4	2483.50	47.95 AV	54.00	-6.05	1.00 V	11	15.39	32.56
5	3282.00	48.76 PK	82.82	-34.06	1.03 V	15	14.24	34.52
6	3282.00	41.05 AV	72.76	-31.71	1.03 V	15	6.53	34.52
7	4924.00	56.58 PK	74.00	-17.42	1.00 V	34	18.12	38.46
8	4924.00	41.92 AV	54.00	-12.08	1.00 V	34	3.46	38.46
9	6565.00	55.72 PK	82.82	-27.10	1.00 V	26	13.70	42.02
10	6565.00	50.38 AV	72.76	-22.38	1.00 V	26	8.36	42.02

- REMARKS:**
1. Emission level (dBuV/m) = Raw Value (dBuV) + Correction Factor (dB/m).
 2. Correction Factor (dB/m) = Antenna Factor (dB/m) + Cable Factor (dB).
 3. The other emission levels were very low against the limit.
 4. Margin value = Emission level – Limit value.
 5. “ * “: Fundamental frequency.



DRAFT 802.11n (40MHz) OFDM MODULATION

EUT TEST CONDITION		MEASUREMENT DETAIL	
CHANNEL	Channel 1	FREQUENCY RANGE	1 ~ 25GHz
INPUT POWER (SYSTEM)	120Vac, 60 Hz	DETECTOR FUNCTION	Peak (PK) Average (AV)
ENVIRONMENTAL CONDITIONS	25deg. C, 66%RH 1016hPa	TESTED BY	Dean Wang

ANTENNA POLARITY & TEST DISTANCE: HORIZONTAL AT 3 M								
NO.	FREQ. (MHz)	EMISSION LEVEL (dBuV/m)	LIMIT (dBuV/m)	MARGIN (dB)	ANTENNA HEIGHT (m)	TABLE ANGLE (Degree)	RAW VALUE (dBuV)	CORRECTION FACTOR (dB/m)
1	2390.00	66.25 PK	74.00	-7.75	1.12 H	325	34.01	32.24
2	2390.00	52.87 AV	54.00	-1.13	1.12 H	325	20.63	32.24
3	*2422.00	102.72 PK			1.06 H	0	70.37	32.35
4	*2422.00	92.24 AV			1.06 H	0	59.89	32.35
5	3230.00	51.40 PK	82.72	-31.32	1.00 H	4	16.90	34.49
6	3230.00	46.29 AV	72.24	-25.95	1.00 H	4	11.79	34.49
7	4844.00	51.57 PK	74.00	-22.43	1.04 H	17	13.37	38.21
8	4844.00	39.19 AV	54.00	-14.81	1.04 H	17	0.99	38.21
9	6458.00	59.29 PK	82.72	-23.43	1.00 H	38	17.69	41.60
10	6458.00	56.27 AV	72.24	-15.97	1.00 H	38	14.67	41.60

- REMARKS:**
1. Emission level (dBuV/m) = Raw Value (dBuV) + Correction Factor (dB/m).
 2. Correction Factor (dB/m) = Antenna Factor (dB/m) + Cable Factor (dB).
 3. The other emission levels were very low against the limit.
 4. Margin value = Emission level – Limit value.
 5. “ * “: Fundamental frequency.



EUT TEST CONDITION		MEASUREMENT DETAIL	
CHANNEL	Channel 1	FREQUENCY RANGE	1 ~ 25GHz
INPUT POWER (SYSTEM)	120Vac, 60 Hz	DETECTOR FUNCTION	Peak (PK) Average (AV)
ENVIRONMENTAL CONDITIONS	25deg. C, 66%RH 1016hPa	TESTED BY	Dean Wang

ANTENNA POLARITY & TEST DISTANCE: VERTICAL AT 3 M								
NO.	FREQ. (MHz)	EMISSION LEVEL (dBuV/m)	LIMIT (dBuV/m)	MARGIN (dB)	ANTENNA HEIGHT (m)	TABLE ANGLE (Degree)	RAW VALUE (dBuV)	CORRECTION FACTOR (dB/m)
1	2386.00	64.08 PK	74.00	-9.92	1.00 V	11	31.85	32.23
2	2386.00	49.85 AV	54.00	-4.15	1.00 V	11	17.62	32.23
3	*2422.00	100.34 PK			1.00 V	11	67.99	32.35
4	*2422.00	90.28 AV			1.00 V	11	57.93	32.35
5	3230.00	49.25 PK	80.34	-31.09	1.03 V	6	14.75	34.49
6	3230.00	42.22 AV	70.28	-28.06	1.03 V	6	7.72	34.49
7	4844.00	53.66 PK	74.00	-20.34	1.00 V	45	15.46	38.21
8	4844.00	41.32 AV	54.00	-12.68	1.00 V	45	3.12	38.21
9	6458.00	58.32 PK	80.34	-22.02	1.00 V	38	16.72	41.60
10	6458.00	54.41 AV	70.28	-15.87	1.00 V	38	12.81	41.60

- REMARKS:**
1. Emission level (dBuV/m) = Raw Value (dBuV) + Correction Factor (dB/m).
 2. Correction Factor (dB/m) = Antenna Factor (dB/m) + Cable Factor (dB).
 3. The other emission levels were very low against the limit.
 4. Margin value = Emission level – Limit value.
 5. “ * “: Fundamental frequency.

EUT TEST CONDITION		MEASUREMENT DETAIL	
CHANNEL	Channel 4	FREQUENCY RANGE	1 ~ 25GHz
INPUT POWER (SYSTEM)	120Vac, 60 Hz	DETECTOR FUNCTION	Peak (PK) Average (AV)
ENVIRONMENTAL CONDITIONS	25deg. C, 66%RH 1016hPa	TESTED BY	Dean Wang

ANTENNA POLARITY & TEST DISTANCE: HORIZONTAL AT 3 M								
NO.	FREQ. (MHz)	EMISSION LEVEL (dBuV/m)	LIMIT (dBuV/m)	MARGIN (dB)	ANTENNA HEIGHT (m)	TABLE ANGLE (Degree)	RAW VALUE (dBuV)	CORRECTION FACTOR (dB/m)
1	*2437.00	102.68 PK			1.08 H	349	70.28	32.40
2	*2437.00	91.98 AV			1.08 H	349	59.58	32.40
3	3249.00	50.81 PK	82.68	-31.87	1.00 H	7	16.31	34.50
4	3249.00	45.03 AV	71.98	-26.95	1.00 H	7	10.53	34.50
5	4874.00	50.52 PK	74.00	-23.48	1.02 H	18	12.20	38.32
6	4874.00	38.11 AV	54.00	-15.89	1.02 H	18	-0.21	38.32
7	6498.00	57.25 PK	82.68	-25.43	1.00 H	41	15.55	41.70
8	6498.00	53.06 AV	71.98	-18.92	1.00 H	41	11.36	41.70
ANTENNA POLARITY & TEST DISTANCE: VERTICAL AT 3 M								
NO.	FREQ. (MHz)	EMISSION LEVEL (dBuV/m)	LIMIT (dBuV/m)	MARGIN (dB)	ANTENNA HEIGHT (m)	TABLE ANGLE (Degree)	RAW VALUE (dBuV)	CORRECTION FACTOR (dB/m)
1	*2437.00	100.26 PK			1.00 V	13	67.86	32.40
2	*2437.00	90.11 AV			1.00 V	13	57.71	32.40
3	3249.00	48.76 PK	80.26	-31.50	1.05 V	9	14.26	34.50
4	3249.00	41.96 AV	70.11	-28.15	1.05 V	9	7.46	34.50
5	4874.00	52.71 PK	74.00	-21.29	1.00 V	58	14.39	38.32
6	4874.00	40.36 AV	54.00	-13.64	1.00 V	58	2.04	38.32
7	6498.00	55.87 PK	80.26	-24.39	1.00 V	41	14.17	41.70
8	6498.00	51.79 AV	70.11	-18.32	1.00 V	41	10.09	41.70

- REMARKS:**
1. Emission level (dBuV/m) = Raw Value (dBuV) + Correction Factor (dB/m).
 2. Correction Factor (dB/m) = Antenna Factor (dB/m) + Cable Factor (dB).
 3. The other emission levels were very low against the limit.
 4. Margin value = Emission level – Limit value.
 5. “ * “: Fundamental frequency.



EUT TEST CONDITION		MEASUREMENT DETAIL	
CHANNEL	Channel 7	FREQUENCY RANGE	1 ~ 25GHz
INPUT POWER (SYSTEM)	120Vac, 60 Hz	DETECTOR FUNCTION	Peak (PK) Average (AV)
ENVIRONMENTAL CONDITIONS	25deg. C, 66%RH 1016hPa	TESTED BY	Dean Wang

ANTENNA POLARITY & TEST DISTANCE: HORIZONTAL AT 3 M								
NO.	FREQ. (MHz)	EMISSION LEVEL (dBuV/m)	LIMIT (dBuV/m)	MARGIN (dB)	ANTENNA HEIGHT (m)	TABLE ANGLE (Degree)	RAW VALUE (dBuV)	CORRECTION FACTOR (dB/m)
1	*2452.00	102.81 PK			1.06 H	358	70.36	32.45
2	*2452.00	92.30 AV			1.06 H	358	59.85	32.45
3	2483.50	67.05 PK	74.00	-6.95	1.06 H	358	34.49	32.56
4	2483.50	52.90 AV	54.00	-1.10	1.06 H	358	20.34	32.56
5	3269.00	50.57 PK	82.81	-32.24	1.00 H	19	16.06	34.51
6	3269.00	44.19 AV	72.30	-28.11	1.00 H	19	9.68	34.51
7	4904.00	50.45 PK	74.00	-23.55	1.02 H	9	12.02	38.43
8	4904.00	37.44 AV	54.00	-16.56	1.02 H	9	-0.99	38.43
9	6538.00	56.03 PK	82.81	-26.78	1.03 H	33	14.14	41.89
10	6538.00	51.79 AV	72.30	-20.51	1.03 H	33	9.90	41.89

- REMARKS:**
1. Emission level (dBuV/m) = Raw Value (dBuV) + Correction Factor (dB/m).
 2. Correction Factor (dB/m) = Antenna Factor (dB/m) + Cable Factor (dB).
 3. The other emission levels were very low against the limit.
 4. Margin value = Emission level – Limit value.
 5. “ * “: Fundamental frequency.



EUT TEST CONDITION		MEASUREMENT DETAIL	
CHANNEL	Channel 7	FREQUENCY RANGE	1 ~ 25GHz
INPUT POWER (SYSTEM)	120Vac, 60 Hz	DETECTOR FUNCTION	Peak (PK) Average (AV)
ENVIRONMENTAL CONDITIONS	25deg. C, 66%RH 1016hPa	TESTED BY	Dean Wang

ANTENNA POLARITY & TEST DISTANCE: VERTICAL AT 3 M								
NO.	FREQ. (MHz)	EMISSION LEVEL (dBuV/m)	LIMIT (dBuV/m)	MARGIN (dB)	ANTENNA HEIGHT (m)	TABLE ANGLE (Degree)	RAW VALUE (dBuV)	CORRECTION FACTOR (dB/m)
1	*2452.00	101.31 PK			1.00 V	28	68.86	32.45
2	*2452.00	90.98 AV			1.00 V	28	58.53	32.45
3	2490.00	64.53 PK	74.00	-9.47	1.00 V	28	31.95	32.58
4	2490.00	50.26 AV	54.00	-3.74	1.00 V	28	17.68	32.58
5	3269.00	48.67 PK	81.31	-32.64	1.00 V	253	14.16	34.51
6	3269.00	41.06 AV	70.98	-29.92	1.00 V	253	6.55	34.51
7	4904.00	52.68 PK	74.00	-21.32	1.00 V	53	14.25	38.43
8	4904.00	39.71 AV	54.00	-14.29	1.00 V	53	1.28	38.43
9	6458.00	54.84 PK	81.31	-26.47	1.00 V	310	13.24	41.60
10	6458.00	49.87 AV	70.98	-21.11	1.00 V	310	8.27	41.60

- REMARKS:**
1. Emission level (dBuV/m) = Raw Value (dBuV) + Correction Factor (dB/m).
 2. Correction Factor (dB/m) = Antenna Factor (dB/m) + Cable Factor (dB).
 3. The other emission levels were very low against the limit.
 4. Margin value = Emission level – Limit value.
 5. “ * “: Fundamental frequency.



BELOW 1GHz WORST-CASE DATA : DRAFT 802.11n (20MHz) OFDM MODULATION

EUT TEST CONDITION		MEASUREMENT DETAIL	
CHANNEL	Channel 1	FREQUENCY RANGE	Below 1000MHz
INPUT POWER (SYSTEM)	120Vac, 60 Hz	DETECTOR FUNCTION	Quasi-Peak
ENVIRONMENTAL CONDITIONS	24deg. C, 63%RH 1016hPa	TESTED BY	Dean Wang

ANTENNA POLARITY & TEST DISTANCE: HORIZONTAL AT 3 M								
NO.	FREQ. (MHz)	EMISSION LEVEL (dBuV/m)	LIMIT (dBuV/m)	MARGIN (dB)	ANTENNA HEIGHT (m)	TABLE ANGLE (Degree)	RAW VALUE (dBuV)	CORRECTION FACTOR (dB/m)
1	119.34	28.88 QP	43.50	-14.62	1.50 H	55	16.32	12.56
2	360.43	36.06 QP	46.00	-9.94	1.00 H	73	19.35	16.71
3	449.87	29.92 QP	46.00	-16.08	1.25 H	97	10.53	19.40
4	599.58	32.27 QP	46.00	-13.73	2.50 H	28	9.82	22.45
5	840.67	41.84 QP	46.00	-4.16	1.00 H	43	15.08	26.76
6	865.94	34.32 QP	46.00	-11.68	1.50 H	118	7.15	27.16
7	930.11	34.05 QP	46.00	-11.95	1.50 H	25	6.02	28.03
ANTENNA POLARITY & TEST DISTANCE: VERTICAL AT 3 M								
NO.	FREQ. (MHz)	EMISSION LEVEL (dBuV/m)	LIMIT (dBuV/m)	MARGIN (dB)	ANTENNA HEIGHT (m)	TABLE ANGLE (Degree)	RAW VALUE (dBuV)	CORRECTION FACTOR (dB/m)
1	119.34	31.85 QP	43.50	-11.65	1.25 V	352	19.29	12.56
2	173.78	31.17 QP	43.50	-12.33	1.00 V	202	17.70	13.47
3	360.43	30.29 QP	46.00	-15.71	2.50 V	118	13.58	16.71
4	731.79	32.04 QP	46.00	-13.96	1.50 V	76	6.92	25.12
5	840.67	36.29 QP	46.00	-9.71	2.00 V	343	9.53	26.76
6	865.94	35.27 QP	46.00	-10.73	1.25 V	178	8.10	27.16
7	932.05	34.20 QP	46.00	-11.80	1.00 V	88	6.14	28.06

- REMARKS:**
1. Emission level (dBuV/m) = Raw Value (dBuV) + Correction Factor (dB/m).
 2. Correction Factor (dB/m) = Antenna Factor (dB/m) + Cable Factor (dB).
 3. The other emission levels were very low against the limit.
 4. Margin value = Emission level – Limit value.

4.2 CONDUCTED EMISSION MEASUREMENT

4.2.1 LIMITS OF CONDUCTED EMISSION MEASUREMENT

FREQUENCY OF EMISSION (MHz)	CONDUCTED LIMIT (dB μ V)	
	Quasi-peak	Average
0.15-0.5	66 to 56	56 to 46
0.5-5	56	46
5-30	60	50

- NOTE:**
1. The lower limit shall apply at the transition frequencies.
 2. The limit decreases in line with the logarithm of the frequency in the range of 0.15 to 0.50 MHz.
 3. All emanations from a class A/B digital device or system, including any network of conductors and apparatus connected thereto, shall not exceed the level of field strengths specified above.

4.2.2 TEST INSTRUMENTS

DESCRIPTION & MANUFACTURER	MODEL NO.	SERIAL NO.	CALIBRATED UNTIL
Test Receiver ROHDE & SCHWARZ	ESCS30	100288	Sep. 21, 2008
RF signal cable Woken	5D-FB	Cable-HYCO3-01	Jan. 06, 2009
LISN ROHDE & SCHWARZ	ESH2-Z5	100100	Jan. 09, 2009
LISN SCHWARZBECK	NNBL 8226-2	8226-142	May 07, 2008
Software ADT	ADT_Cond_V3	NA	NA

- NOTE:**
1. The calibration interval of the above test instruments is 12 months and the calibrations are traceable to NML/ROC and NIST/USA.
 2. The test was performed in HwaYa Shielded Room 2.
 3. The VCCI Site Registration No. is C-2047.

4.2.3 TEST PROCEDURES

- a. The EUT was placed 0.4 meters from the conducting wall of the shielded room with EUT being connected to the power mains through a line impedance stabilization network (LISN). Other support units were connected to the power mains through another LISN. The two LISNs provide 50 ohm/ 50uH of coupling impedance for the measuring instrument.
- b. Both lines of the power mains connected to the EUT were checked for maximum conducted interference.
- c. The frequency range from 150kHz to 30MHz was searched. Emission levels under (Limit - 20dB) was not recorded.

NOTE: All modes of operation were investigated and the worst-case emissions are reported.

4.2.4 DEVIATION FROM TEST STANDARD

No deviation.

4.2.5 TEST SETUP

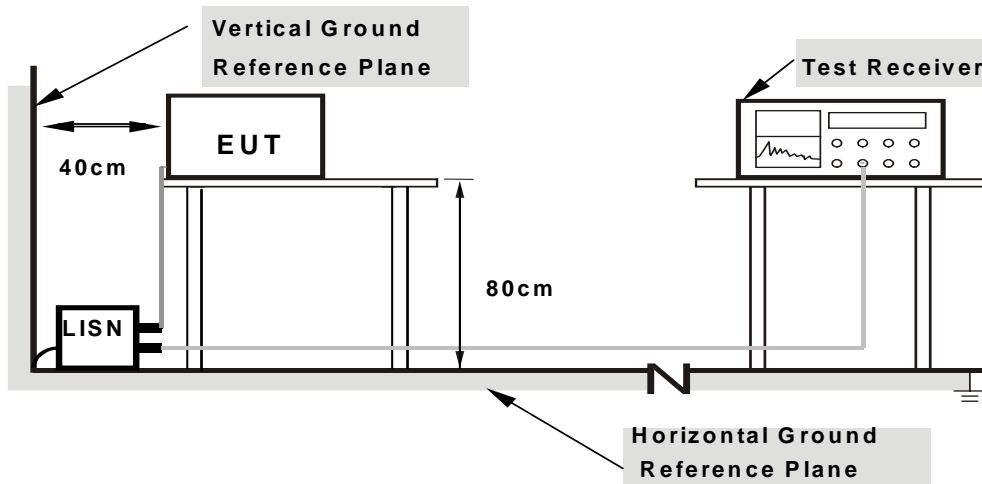

- Note:**
1. Support units were connected to second LISN.
 2. Both of LISNs (AMN) are 80 cm from EUT and at least 80 cm from other units and other metal planes

For the actual test configuration, please refer to the attached file (Test Setup Photo).

4.2.6 EUT OPERATING CONDITIONS

Same as 4.1.6.

4.2.7 TEST RESULTS

CONDUCTED WORST-CASE DATA: 802.11n (20MHz) OFDM MODULATION

EUT TEST CONDITION		MEASUREMENT DETAIL	
CHANNEL	Channel 1	PHASE	Line 1
MODULATION TYPE	BPSK	6dB BANDWIDTH	9 kHz
INPUT POWER (SYSTEM)	120Vac, 60 Hz	ENVIRONMENTAL CONDITIONS	20deg. C, 60%RH, 1016hPa
TESTED BY	Match Tsui		

No	Freq. [MHz]	Corr. Factor (dB)	Reading Value [dB (uV)]		Emission Level [dB (uV)]		Limit [dB (uV)]		Margin (dB)	
			Q.P.	AV.	Q.P.	AV.	Q.P.	AV.	Q.P.	AV.
1	0.173	0.10	51.18	-	51.28	-	64.79	54.79	-13.51	-
2	0.233	0.10	43.21	-	43.31	-	62.33	52.33	-19.02	-
3	0.406	0.10	32.03	-	32.13	-	57.72	47.72	-25.59	-
4	1.918	0.21	30.60	-	30.81	-	56.00	46.00	-25.19	-
5	3.836	0.28	39.50	-	39.78	-	56.00	46.00	-16.22	-
6	22.328	0.69	25.36	-	26.05	-	60.00	50.00	-33.95	-

- REMARKS:**
1. Q.P. and AV. are abbreviations of quasi-peak and average individually.
 2. "-": The Quasi-peak reading value also meets average limit and measurement with the average detector is unnecessary.
 3. The emission levels of other frequencies were very low against the limit.
 4. Margin value = Emission level - Limit value
 5. Correction factor = Insertion loss + Cable loss
 6. Emission Level = Correction Factor + Reading Value.

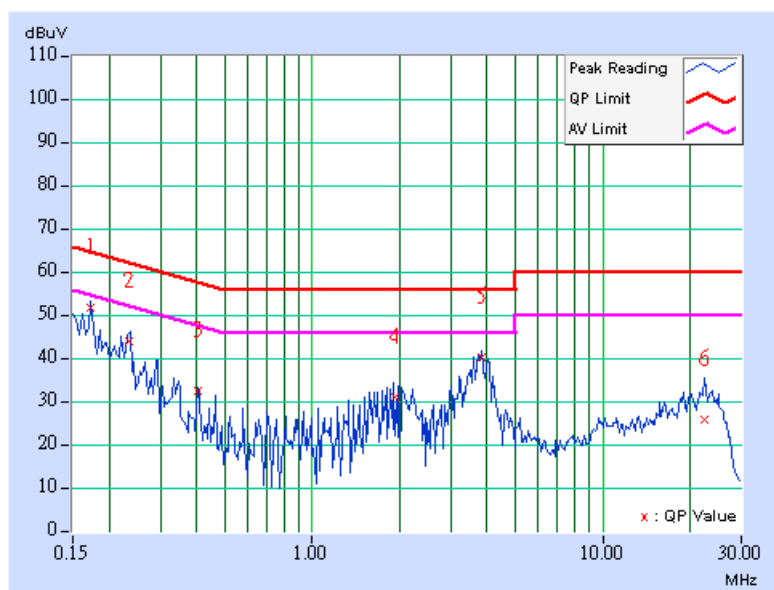

EUT TEST CONDITION		MEASUREMENT DETAIL	
CHANNEL	Channel 1	PHASE	Line 2
MODULATION TYPE	BPSK	6dB BANDWIDTH	9 kHz
INPUT POWER (SYSTEM)	120Vac, 60 Hz	ENVIRONMENTAL CONDITIONS	20deg. C, 60%RH, 1016hPa
TESTED BY	Match Tsui		

No	Freq. [MHz]	Corr. Factor (dB)	Reading Value [dB (uV)]		Emission Level [dB (uV)]		Limit [dB (uV)]		Margin (dB)	
			Q.P.	AV.	Q.P.	AV.	Q.P.	AV.	Q.P.	AV.
			1	0.173	0.10	47.98	-	48.08	-	64.79
2	0.232	0.10	39.18	-	39.28	-	62.37	52.37	-23.09	-
3	0.408	0.10	27.40	-	27.50	-	57.69	47.69	-30.19	-
4	2.094	0.22	30.64	-	30.86	-	56.00	46.00	-25.14	-
5	3.836	0.28	39.91	-	40.19	-	56.00	46.00	-15.81	-
6	24.457	0.70	21.28	-	21.98	-	60.00	50.00	-38.02	-

- REMARKS:**
1. Q.P. and AV. are abbreviations of quasi-peak and average individually.
 2. "-": The Quasi-peak reading value also meets average limit and measurement with the average detector is unnecessary.
 3. The emission levels of other frequencies were very low against the limit.
 4. Margin value = Emission level - Limit value
 5. Correction factor = Insertion loss + Cable loss
 6. Emission Level = Correction Factor + Reading Value.

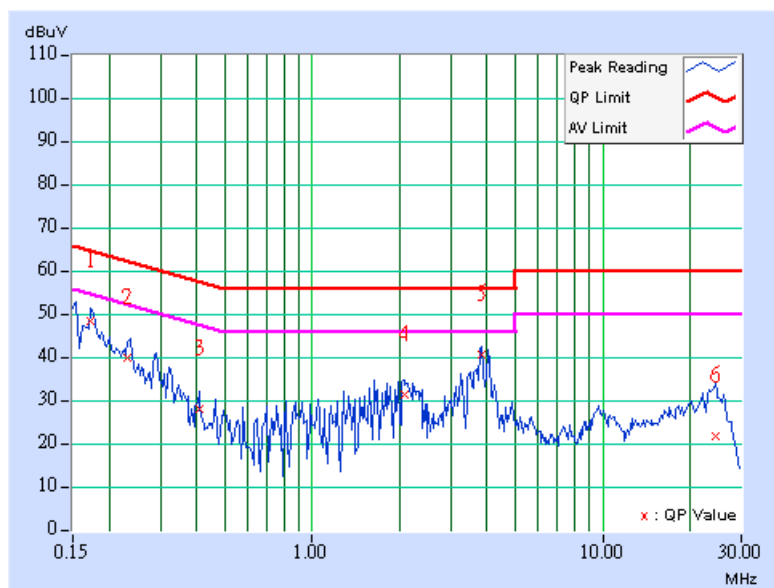



4.3 6dB BANDWIDTH MEASUREMENT

4.3.1 LIMITS OF 6dB BANDWIDTH MEASUREMENT

The minimum of 6dB Bandwidth Measurement is 0.5 MHz.

4.3.2 TEST INSTRUMENTS

DESCRIPTION & MANUFACTURER	MODEL NO.	SERIAL NO.	CALIBRATED UNTIL
SPECTRUM ANALYZER	FSP 40	100040	Jun. 28, 2008

NOTE: The calibration interval of the above test instruments is 12 months and the calibrations are traceable to NML/ROC and NIST/USA.

4.3.3 TEST PROCEDURE

The transmitter output was connected to the spectrum analyzer through an attenuator. The bandwidth of the fundamental frequency was measured by spectrum analyzer with 100kHz RBW and 100kHz VBW. The 6dB bandwidth is defined as the total spectrum the power of which is higher than peak power minus 6dB.

4.3.4 DEVIATION FROM TEST STANDARD

No deviation.

4.3.5 TEST SETUP

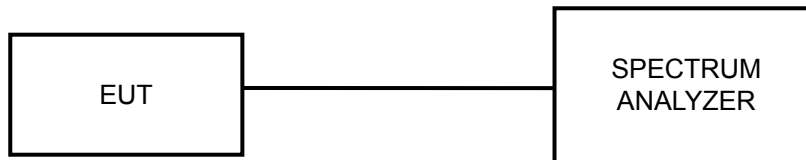

4.3.6 EUT OPERATING CONDITIONS

The software provided by client to enable the EUT under transmission condition continuously at lowest, middle and highest channel frequencies individually.

4.3.7 TEST RESULTS

802.11b DSSS MODULATION

MODULATION TYPE	DBPSK	TRANSFER RATE	1.0Mbps
INPUT POWER (SYSTEM)	120Vac, 60 Hz	ENVIRONMENTAL CONDITIONS	25deg.C, 65%RH, 991hPa
TESTED BY	Brad Wu		

CHANNEL	CHANNEL FREQUENCY (MHz)	6dB BANDWIDTH (MHz)	MINIMUM LIMIT (MHz)	PASS / FAIL
1	2412	12.16	0.5	PASS
6	2437	12.18	0.5	PASS
11	2462	12.15	0.5	PASS

CH 1

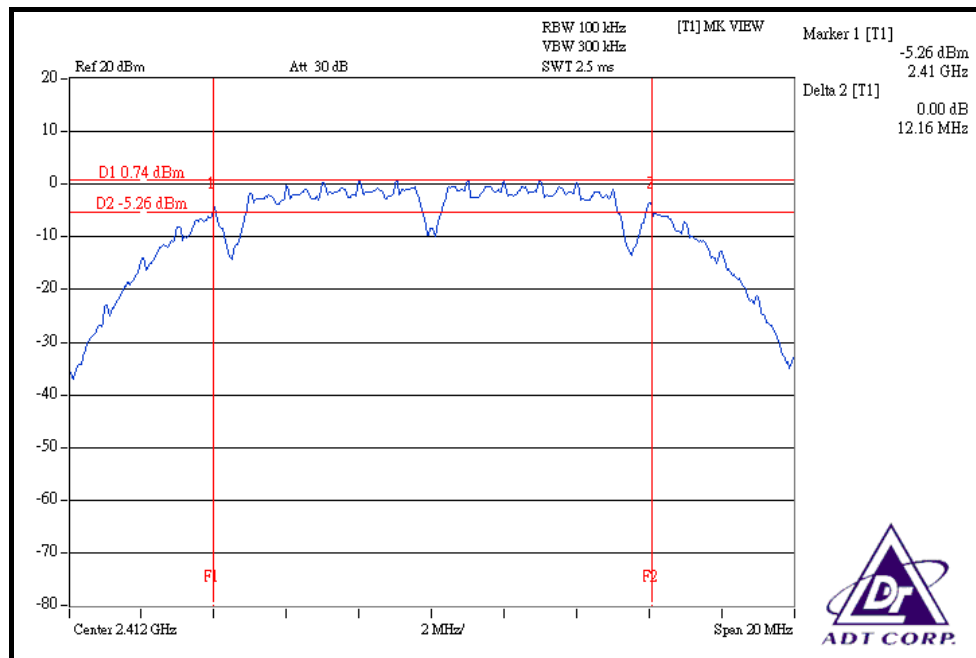

CH 6

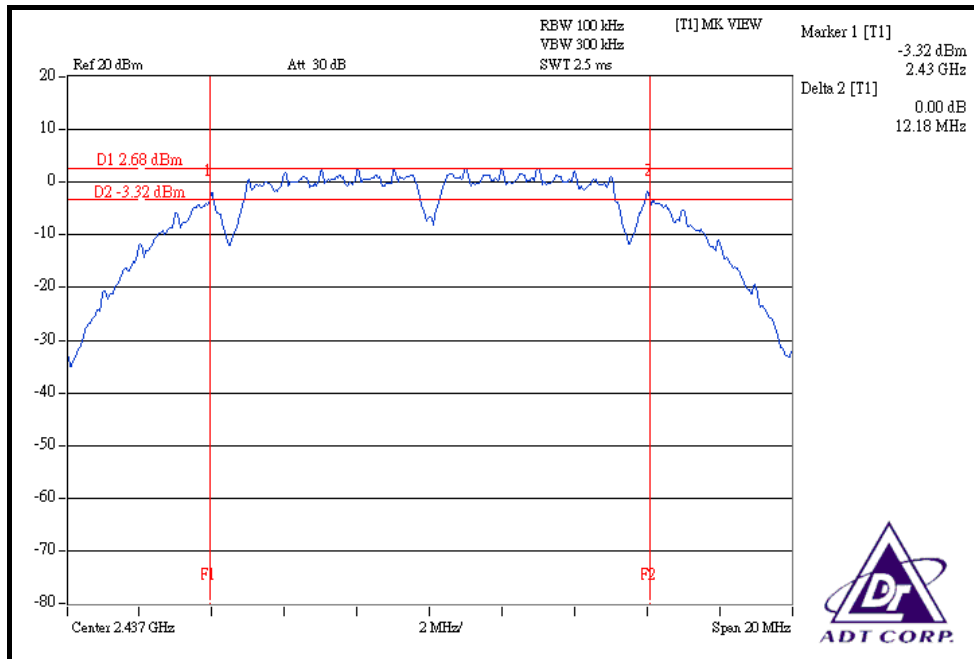

CH 11

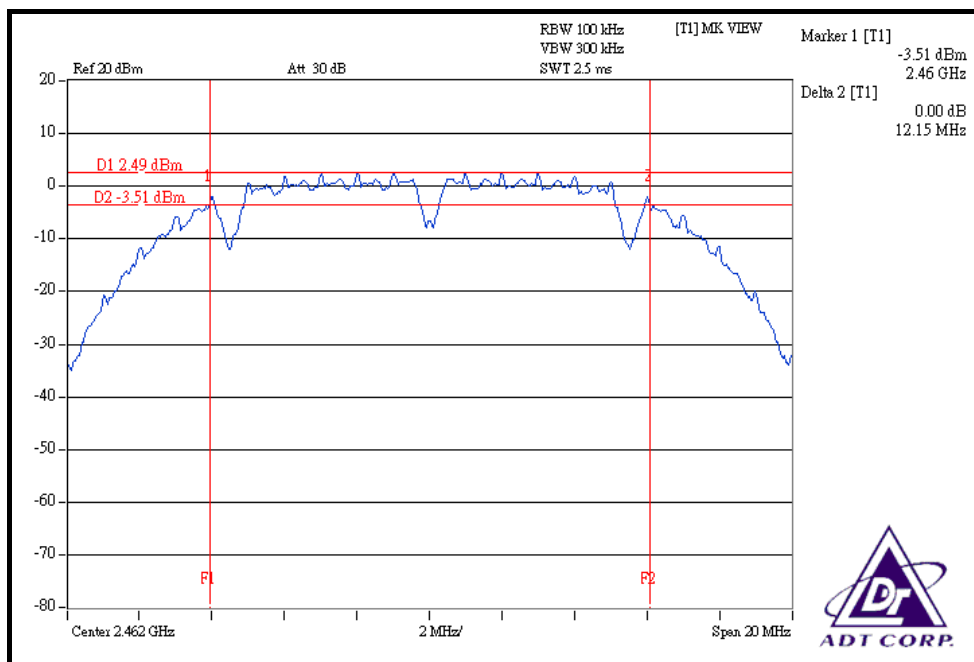



802.11g OFDM MODULATION

MODULATION TYPE	BPSK	TRANSFER RATE	6.0Mbps
INPUT POWER (SYSTEM)	120Vac, 60 Hz	ENVIRONMENTAL CONDITIONS	25deg.C, 65%RH, 991hPa
TESTED BY	Brad Wu		

CHANNEL	CHANNEL FREQUENCY (MHz)	6dB BANDWIDTH (MHz)		MINIMUM LIMIT (MHz)	PASS / FAIL
		CHAIN 0	CHAIN 1		
1	2412	16.61	16.63	0.5	PASS
6	2437	16.61	16.59	0.5	PASS
11	2462	16.63	16.61	0.5	PASS

FOR CHAIN 0: CH 1

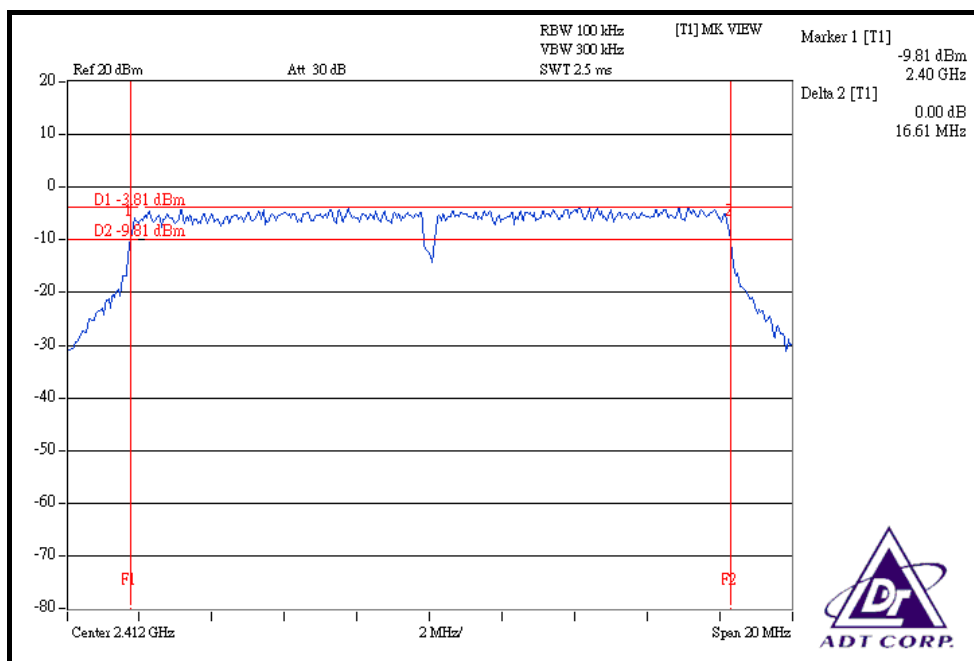

CH 6

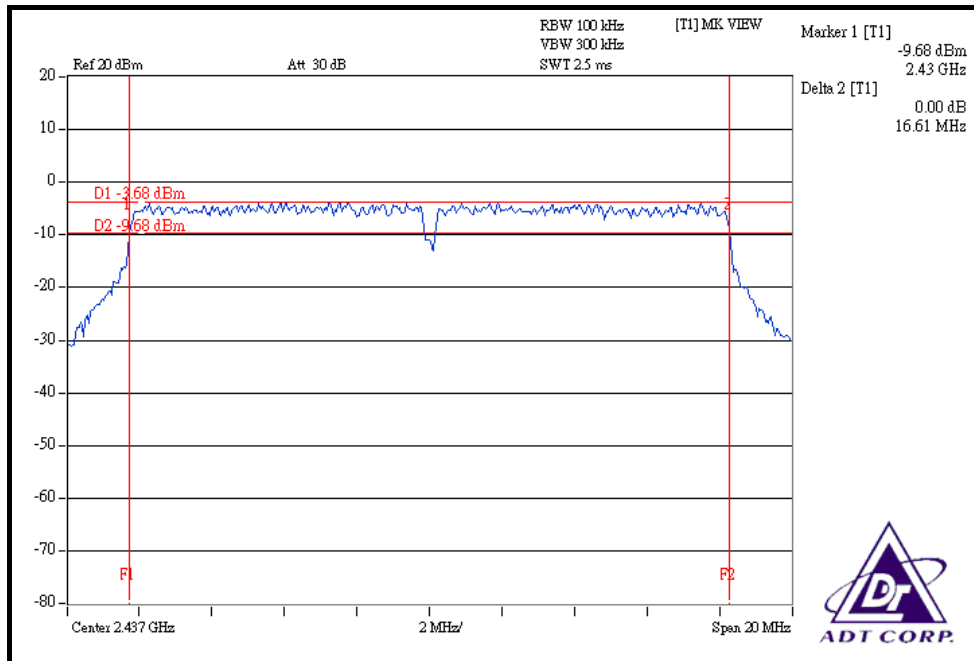

CH 11

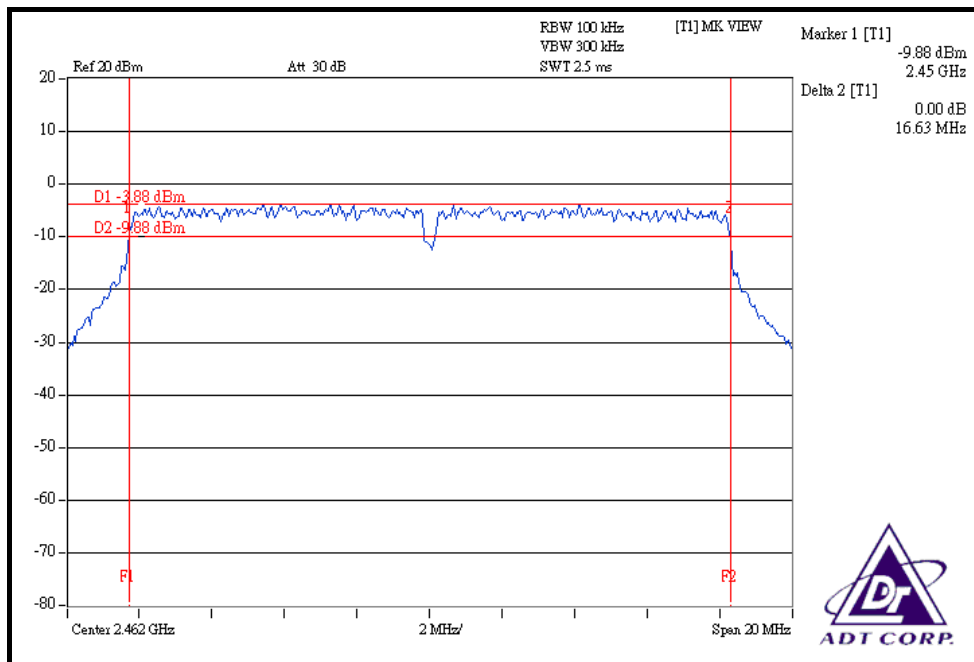

FOR CHAIN 1: CH 1

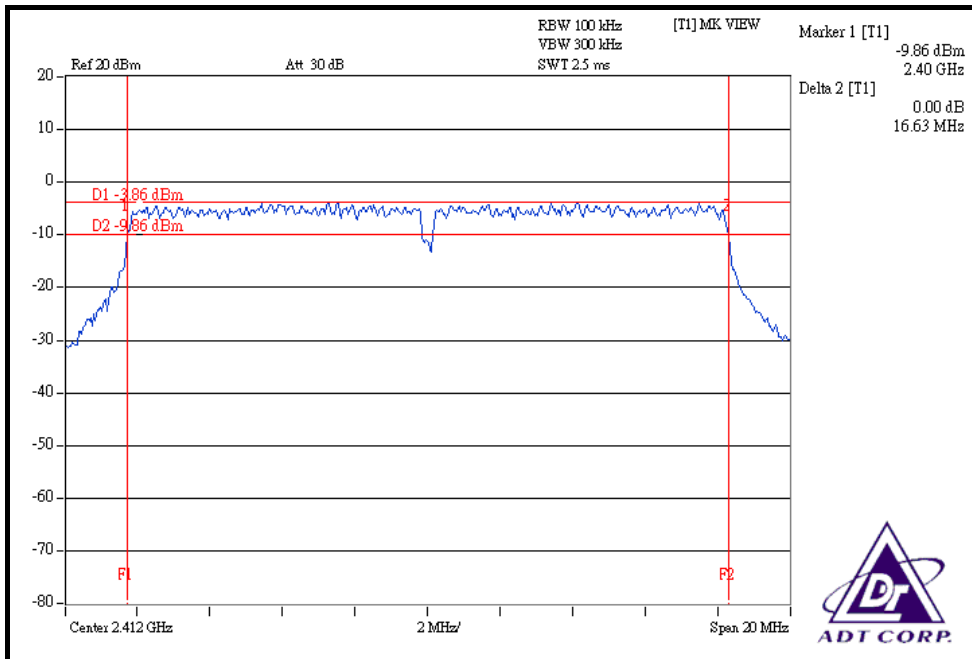

CH 6

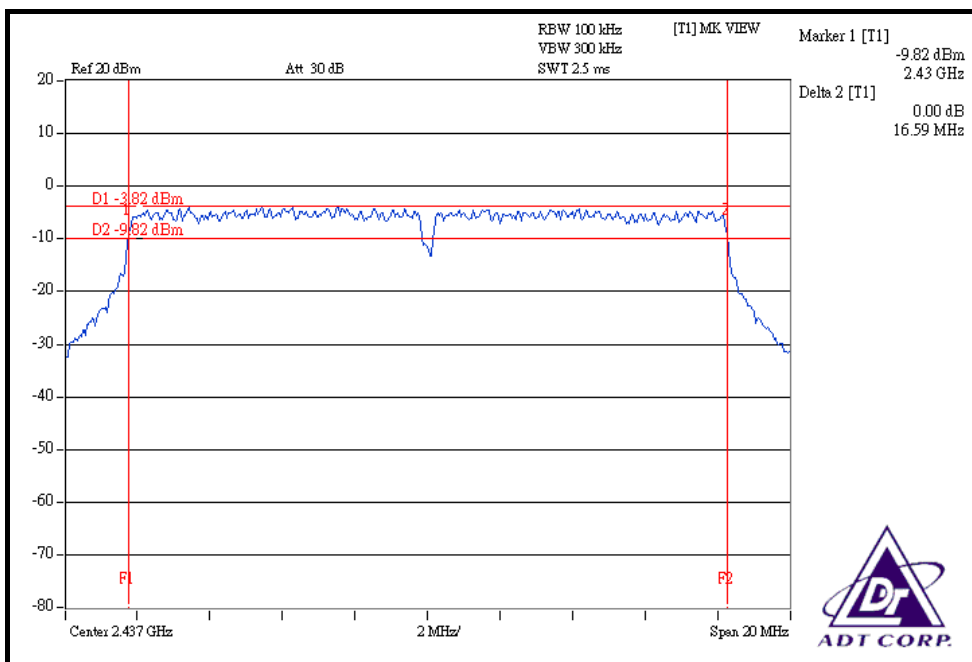

CH 11

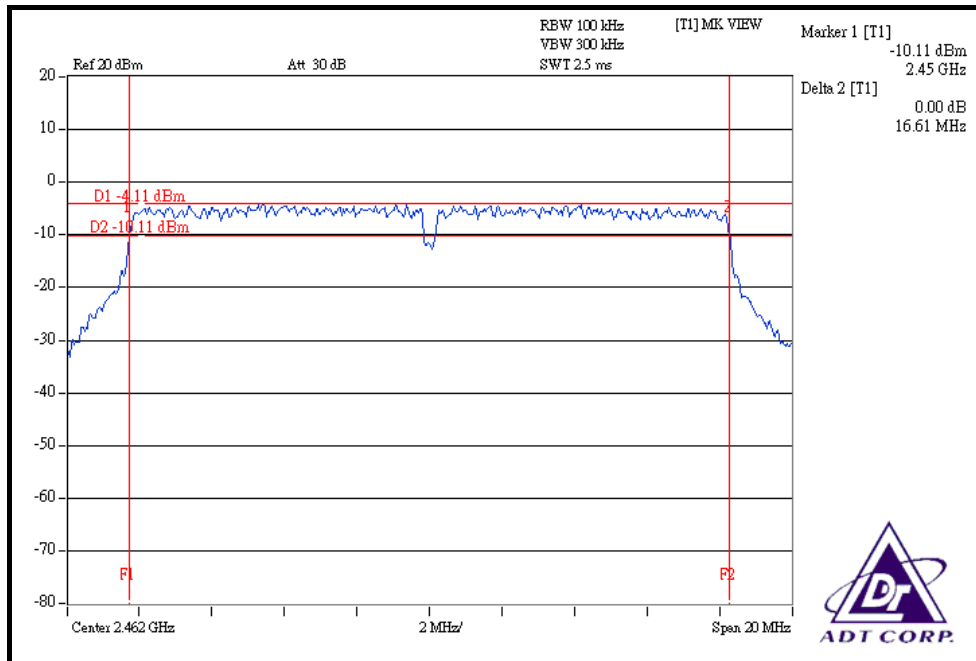



DRAFT 802.11n (20MHz) OFDM MODULATION

MODULATION TYPE	BPSK	TRANSFER RATE	7.2Mbps
INPUT POWER (SYSTEM)	120Vac, 60 Hz	ENVIRONMENTAL CONDITIONS	25deg.C, 65%RH, 991hPa
TESTED BY	Brad Wu		

CHANNEL	CHANNEL FREQUENCY (MHz)	6dB BANDWIDTH (MHz)		MINIMUM LIMIT (MHz)	PASS / FAIL
		CHAIN 0	CHAIN 1		
1	2412	17.72	17.75	0.5	PASS
6	2437	17.68	17.75	0.5	PASS
11	2462	17.73	17.75	0.5	PASS

FOR CHAIN 0: CH 1

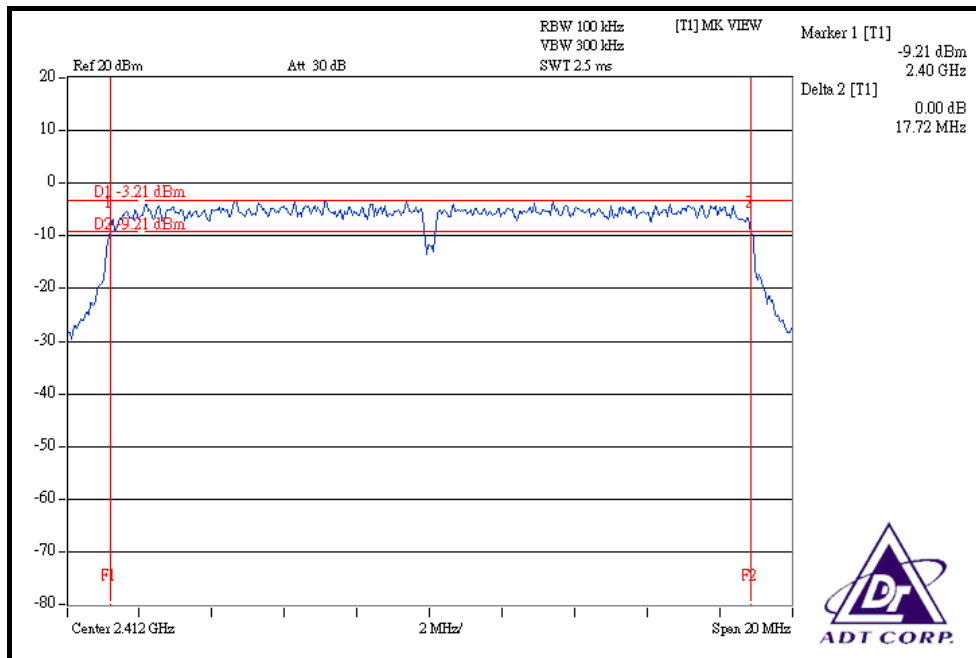

CH 6

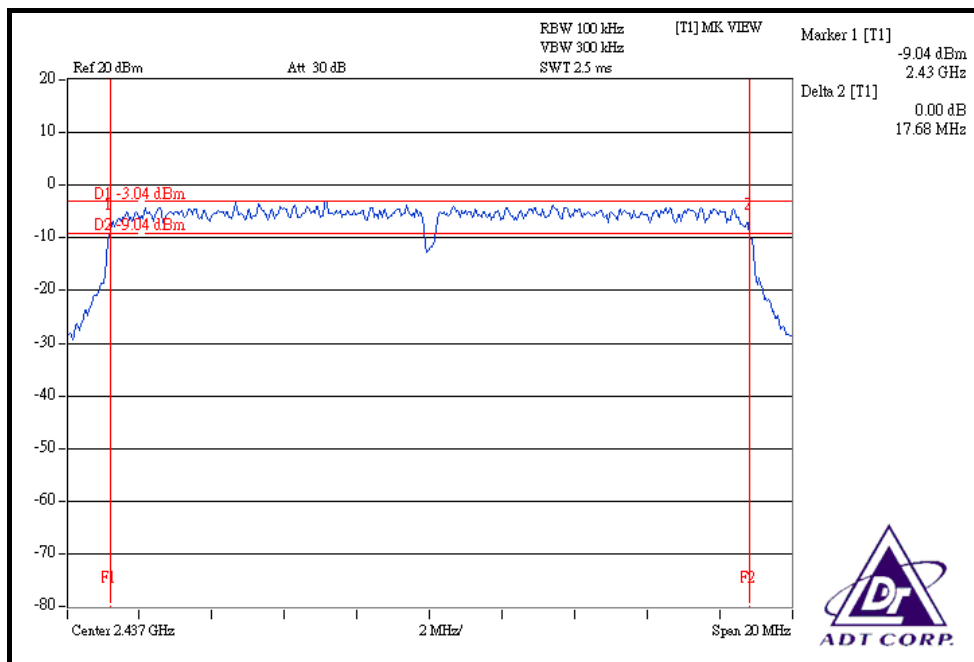

CH 11

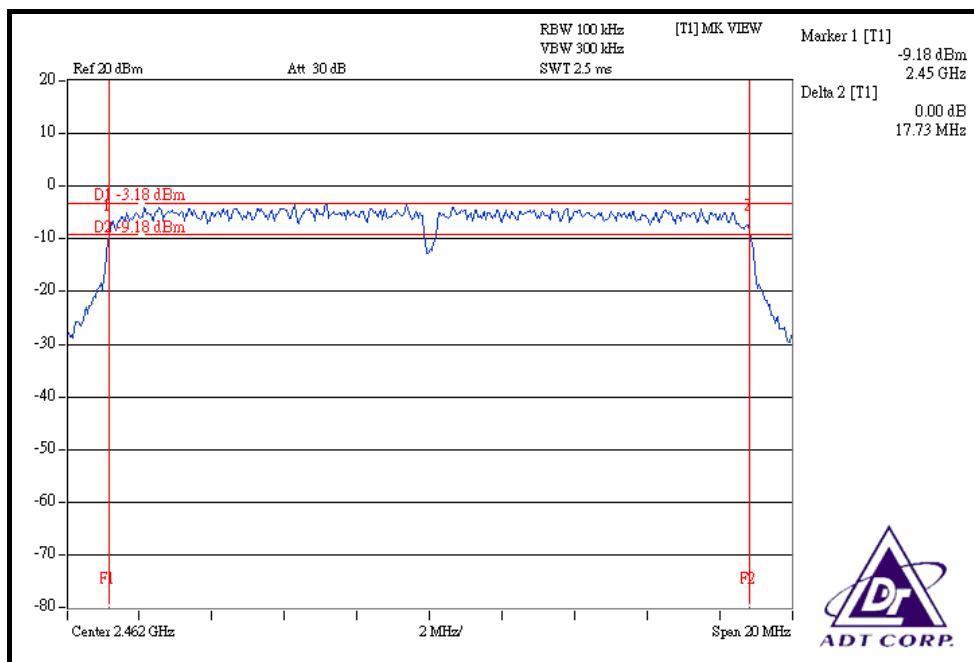

FOR CHAIN 1: CH 1

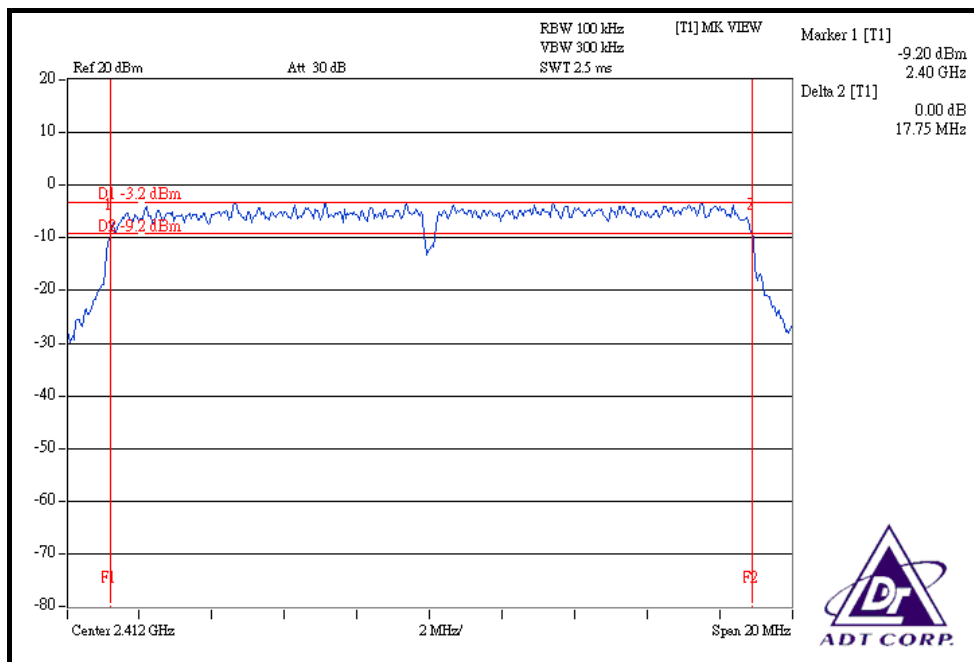

CH 6

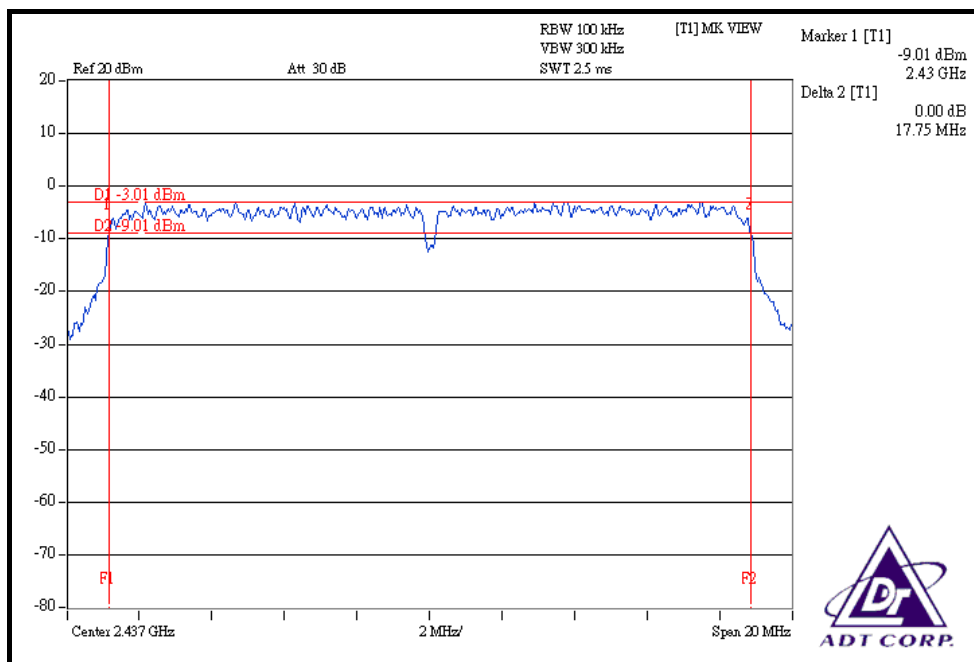

CH 11

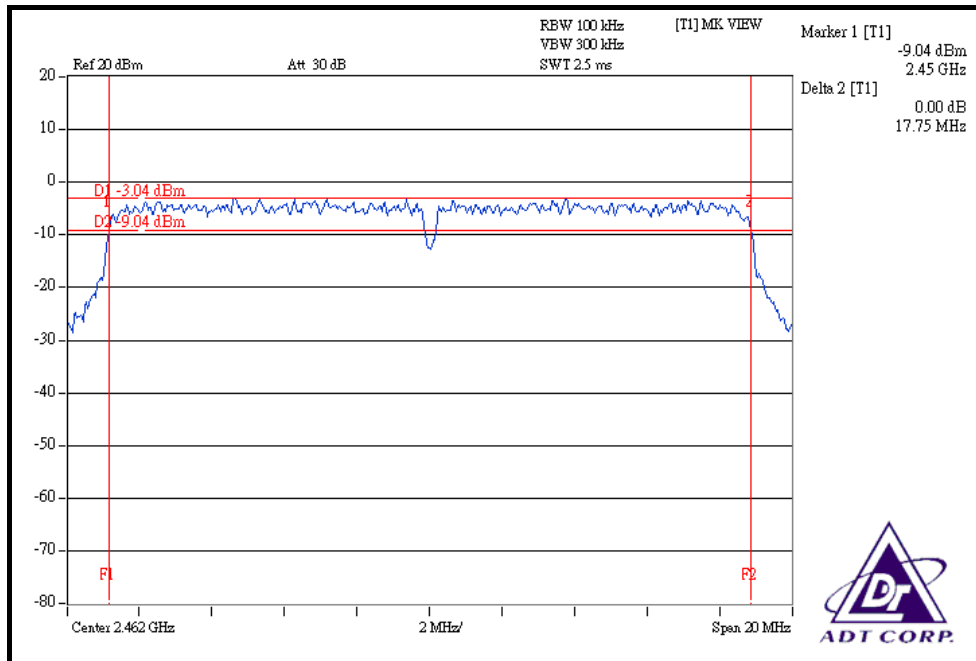



DRAFT 802.11n (40MHz) OFDM MODULATION

MODULATION TYPE	BPSK	TRANSFER RATE	15.0Mbps
INPUT POWER (SYSTEM)	120Vac, 60 Hz	ENVIRONMENTAL CONDITIONS	25deg.C, 65%RH, 991hPa
TESTED BY	Brad Wu		

CHANNEL	CHANNEL FREQUENCY (MHz)	6dB BANDWIDTH (MHz)		MINIMUM LIMIT (MHz)	PASS / FAIL
		CHAIN 0	CHAIN 1		
1	2422	36.46	36.45	0.5	PASS
4	2437	36.50	36.49	0.5	PASS
7	2452	36.53	36.54	0.5	PASS

FOR CHAIN 0: CH 1

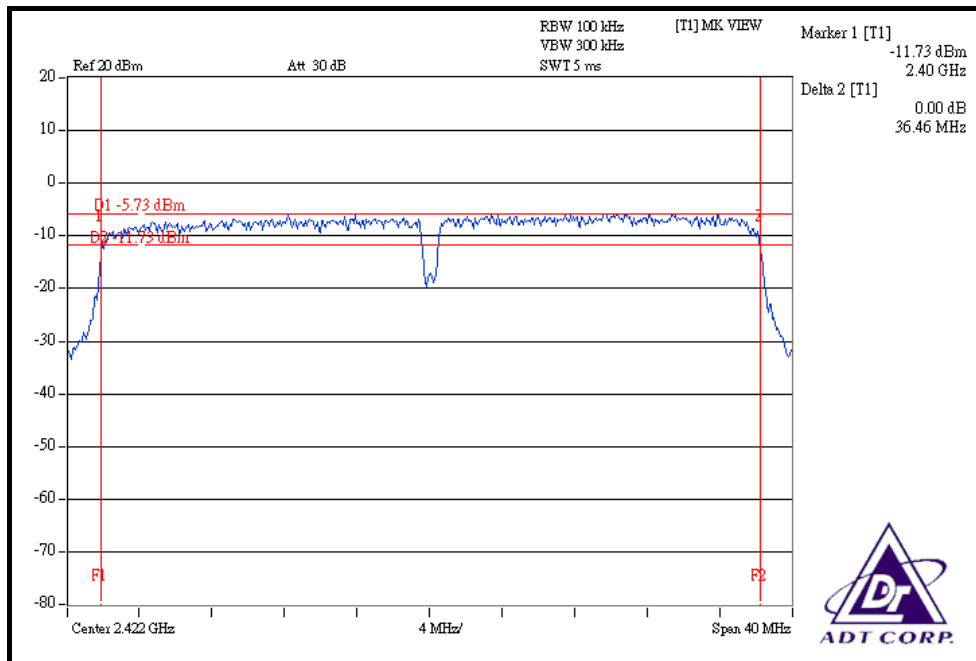

CH 4

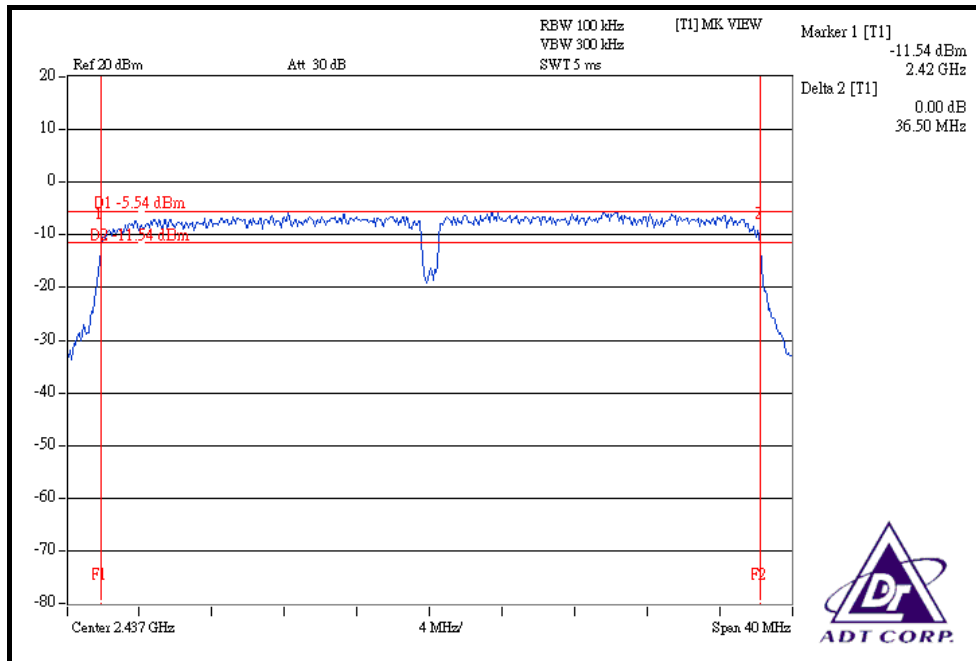

CH 7

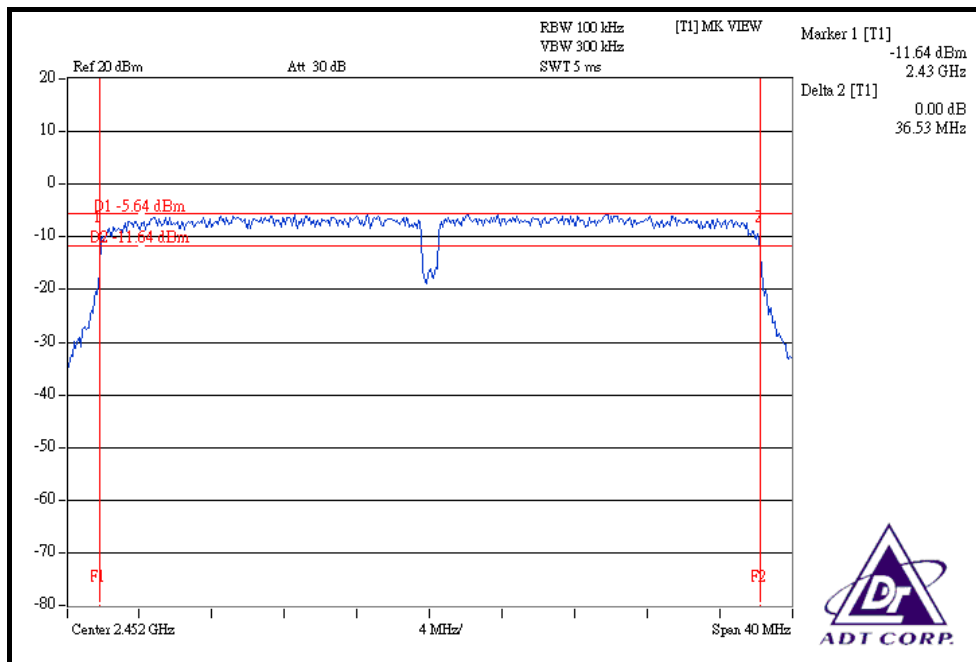

FOR CHAIN 1: CH 1

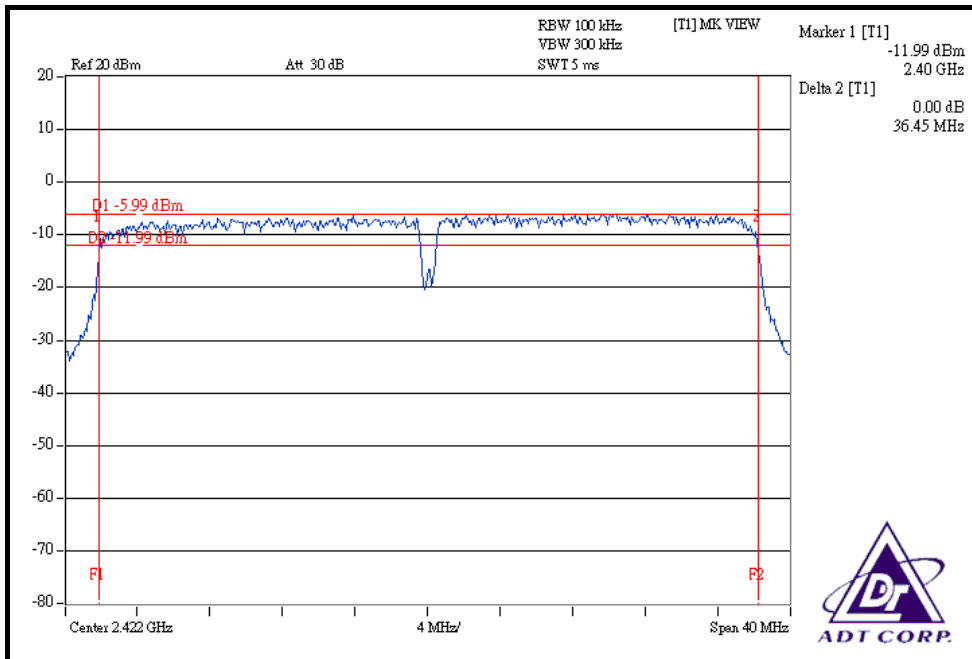

CH 4

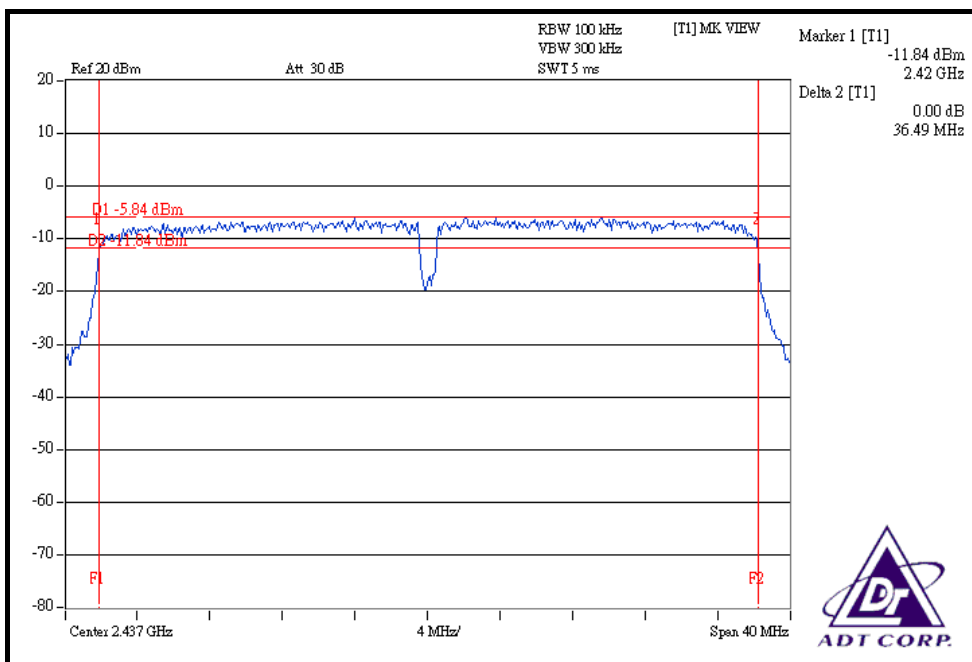

CH 7

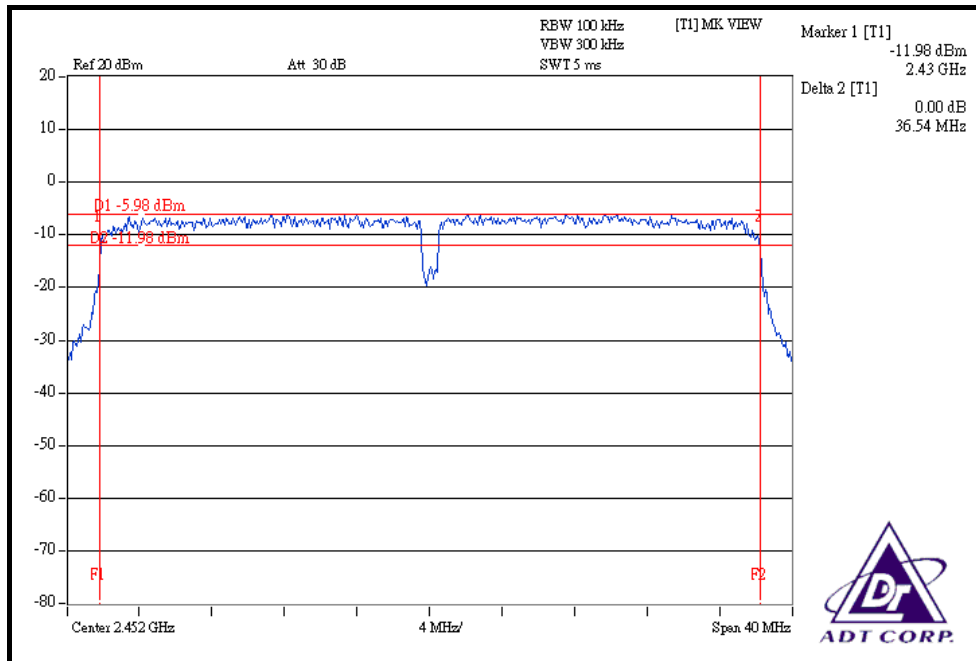



4.4 MAXIMUM PEAK OUTPUT POWER

4.4.1 LIMITS OF MAXIMUM PEAK OUTPUT POWER MEASUREMENT

The Maximum Peak Output Power Measurement is 30dBm.

4.4.2 INSTRUMENTS

DESCRIPTION & MANUFACTURER	MODEL NO.	SERIAL NO.	CALIBRATED UNTIL
SPECTRUM ANALYZER	FSP40	100040	Jun. 28, 2008
AGILENT SYNTHESIZED SIGNAL GENERATOR	E8257C	MY43320668	Dec. 25, 2008
DIGITAL RT OSCILLOSCOPE	TDS1012	C037299	Nov. 21, 2008
NARDA DETECTOR	4503A	FSCM99899	NA

NOTE: The calibration interval of the above test instruments is 12 months and the calibrations are traceable to NML/ROC and NIST/USA.

4.4.3 TEST PROCEDURES

- a. A detector was used on the output port of the EUT. An oscilloscope was used to read the response of the detector.
- b. Replaced the EUT by the signal generator. The center frequency of the S.G was adjusted to the center frequency of the measured channel.
- c. Adjusted the power to have the same reading on oscilloscope. Record the power level.

4.4.4 DEVIATION FROM TEST STANDARD

No deviation.

4.4.5 TEST SETUP



4.4.6 EUT OPERATING CONDITIONS

Same as Item 4.3.6.



4.4.7 TEST RESULTS

802.11b DSSS MODULATION

MODULATION TYPE	DBPSK	TRANSFER RATE	1.0Mbps
INPUT POWER (SYSTEM)	120Vac, 60 Hz	ENVIRONMENTAL CONDITIONS	25deg.C, 65%RH, 991hPa
TESTED BY	Brad Wu		

CHAN	CHANNEL FREQUENCY (MHz)	PEAK POWER OUTPUT (mW)	PEAK POWER OUTPUT (dBm)	PEAK POWER LIMIT (dBm)	PASS/FAIL
1	2412	35.892	15.55	30	PASS
6	2437	56.624	17.53	30	PASS
11	2462	56.494	17.52	30	PASS

802.11g OFDM MODULATION

MODULATION TYPE	BPSK	TRANSFER RATE	6.0Mbps
INPUT POWER (SYSTEM)	120Vac, 60 Hz	ENVIRONMENTAL CONDITIONS	25deg.C, 65%RH, 991hPa
TESTED BY	Brad Wu		

CHANNEL	CHANNEL FREQUENCY (MHz)	PEAK POWER OUTPUT (dBm)		TOTAL PEAK POWER (mW)	TOTAL PEAK POWER (dBm)	PEAK POWER LIMIT (dBm)	PASS / FAIL
		CHAIN 0	CHAIN 1				
1	2412	15.03	15.00	63.465	18.03	30	PASS
6	2437	15.00	15.07	63.759	18.05	30	PASS
11	2462	15.05	15.00	63.612	18.04	30	PASS



DRAFT 802.11n (20MHz) OFDM MODULATION

MODULATION TYPE	BPSK	TRANSFER RATE	7.2Mbps
INPUT POWER (SYSTEM)	120Vac, 60 Hz	ENVIRONMENTAL CONDITIONS	25deg.C, 65%RH, 991hPa
TESTED BY	Brad Wu		

CHANNEL	CHANNEL FREQUENCY (MHz)	PEAK POWER OUTPUT (dBm)		TOTAL PEAK POWER (mW)	TOTAL PEAK POWER (dBm)	PEAK POWER LIMIT (dBm)	PASS / FAIL
		CHAIN 0	CHAIN 1				
1	2412	15.12	15.06	64.571	18.10	30	PASS
6	2437	15.09	15.00	63.908	18.06	30	PASS
11	2462	15.04	15.06	63.978	18.06	30	PASS

DRAFT 802.11n (40MHz) OFDM MODULATION

MODULATION TYPE	BPSK	TRANSFER RATE	15.0Mbps
INPUT POWER (SYSTEM)	120Vac, 60 Hz	ENVIRONMENTAL CONDITIONS	25deg.C, 65%RH, 991hPa
TESTED BY	Brad Wu		

CHANNEL	CHANNEL FREQUENCY (MHz)	PEAK POWER OUTPUT (dBm)		TOTAL PEAK POWER (mW)	TOTAL PEAK POWER (dBm)	PEAK POWER LIMIT (dBm)	PASS / FAIL
		CHAIN 0	CHAIN 1				
1	2422	15.04	15.10	64.275	18.08	30	PASS
4	2437	15.01	15.04	63.611	18.04	30	PASS
7	2452	15.11	15.11	64.868	18.12	30	PASS



4.5 POWER SPECTRAL DENSITY MEASUREMENT

4.5.1 LIMITS OF POWER SPECTRAL DENSITY MEASUREMENT

The Maximum of Power Spectral Density Measurement is 8dBm.

4.5.2 TEST INSTRUMENTS

DESCRIPTION & MANUFACTURER	MODEL NO.	SERIAL NO.	CALIBRATED UNTIL
R&S SPECTRUM ANALYZER	FSP 40	100040	Jun. 28, 2008

NOTE: The calibration interval of the above test instruments is 12 months and the calibrations are traceable to NML/ROC and NIST/USA.

4.5.3 TEST PROCEDURE

The transmitter output was connected to the spectrum analyzer through an attenuator, the bandwidth of the fundamental frequency was measured with the spectrum analyzer using 3kHz RBW and 30kHz VBW, set sweep time = span/3kHz. The power spectral density was measured and recorded.

The sweep time is allowed to be longer than span/3kHz for a full response of the mixer in the spectrum analyzer.

4.5.4 DEVIATION FROM TEST STANDARD

No deviation.

4.5.5 TEST SETUP

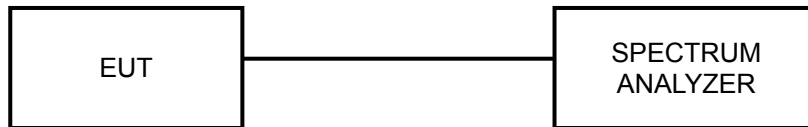

4.5.6 EUT OPERATING CONDITION

Same as Item 4.3.6.



4.5.7 TEST RESULTS

802.11b DSSS MODULATION

MODULATION TYPE	DBPSK	TRANSFER RATE	1.0Mbps
INPUT POWER (SYSTEM)	120Vac, 60 Hz	ENVIRONMENTAL CONDITIONS	25deg.C, 65%RH, 991hPa
TESTED BY	Brad Wu		

CHANNEL	CHANNEL FREQUENCY (MHz)	RF POWER LEVEL IN 3 kHz BW (dBm)	MAXIMUM LIMIT (dBm)	PASS/FAIL
1	2412	-17.55	8	PASS
6	2437	-15.61	8	PASS
11	2462	-15.73	8	PASS

CH 1

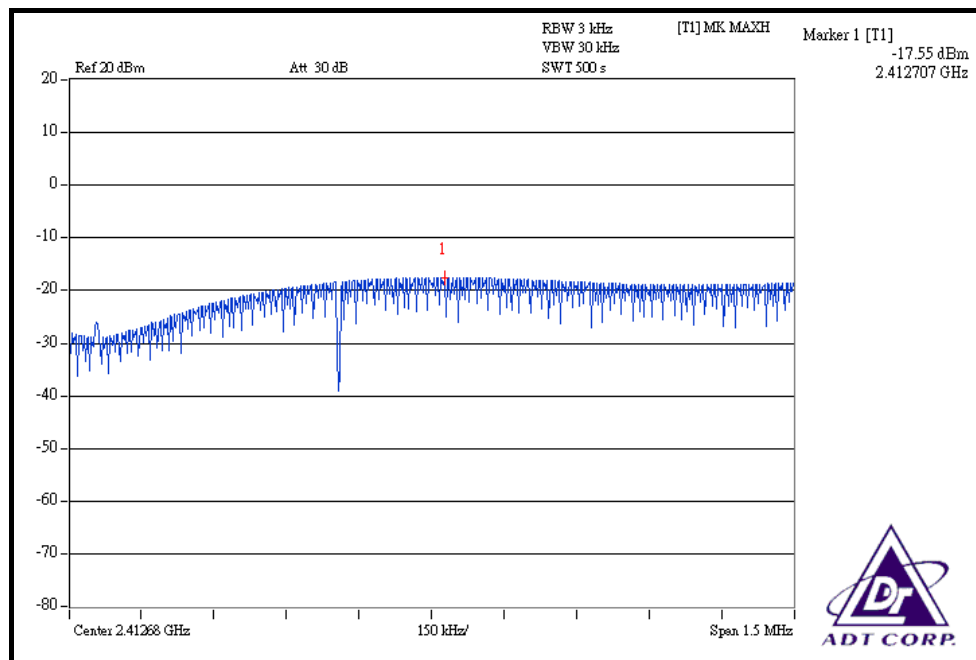

CH 6

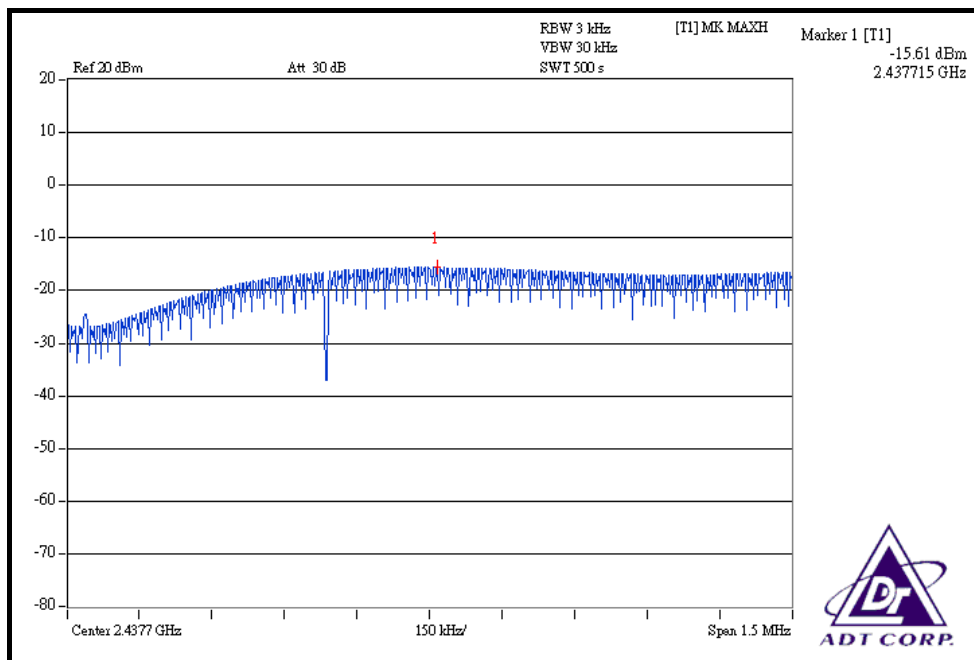

CH 11

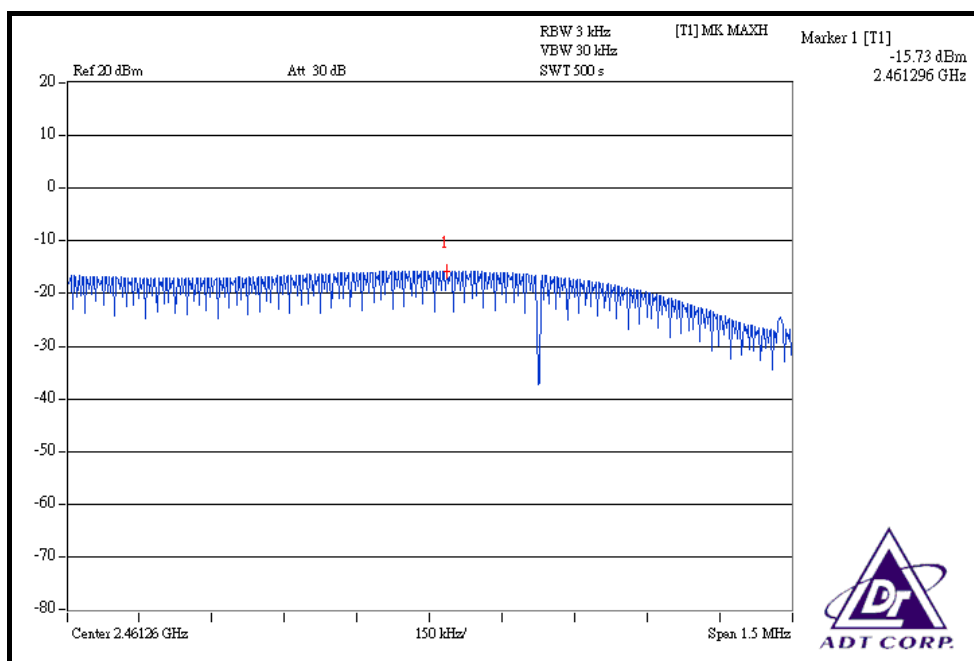

FOR CHAIN 1: CH 1

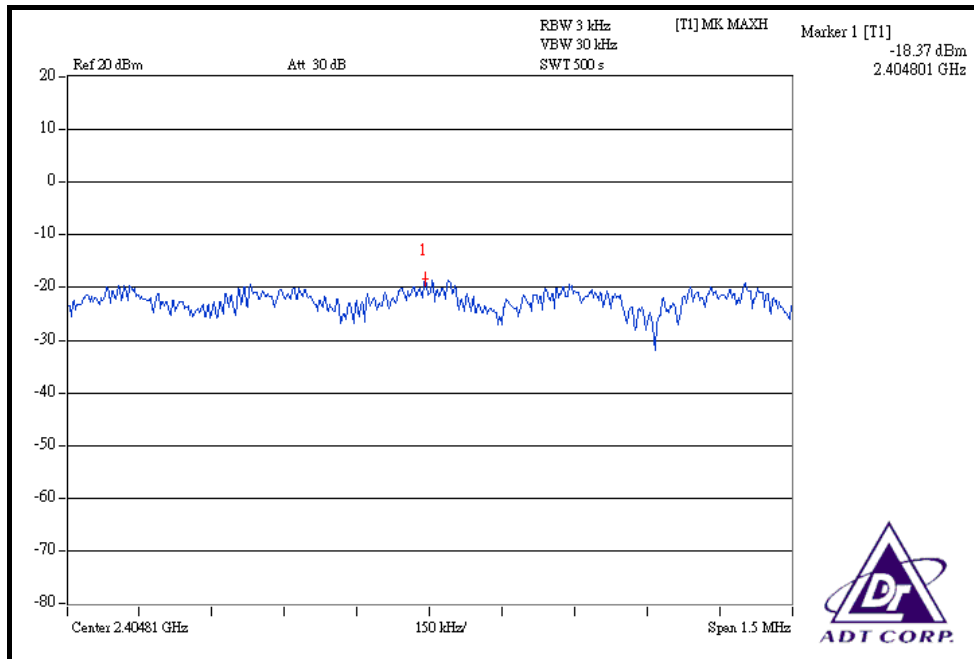

CH 6

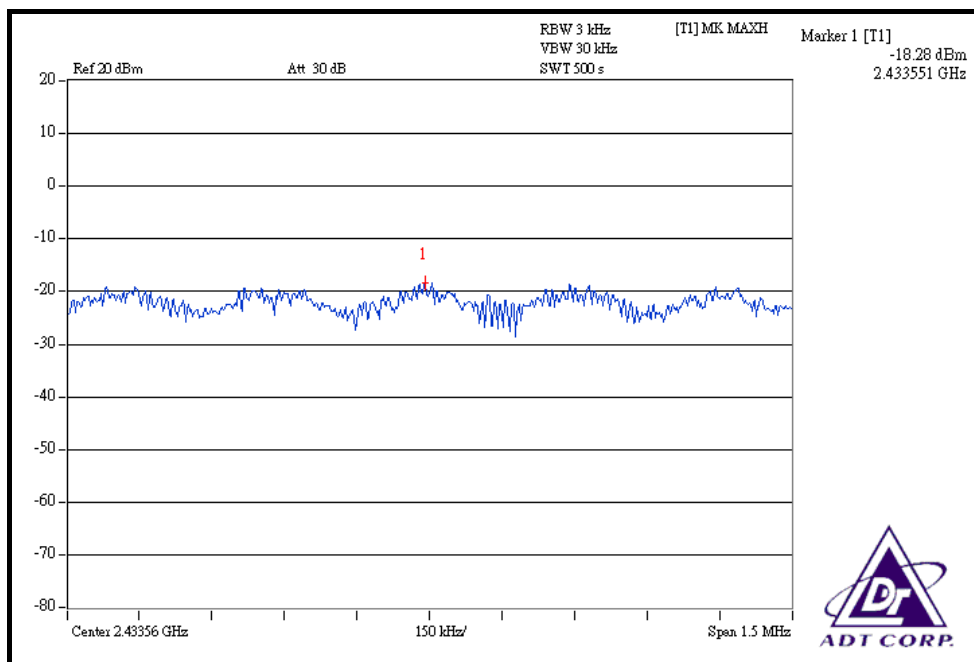

CH 11

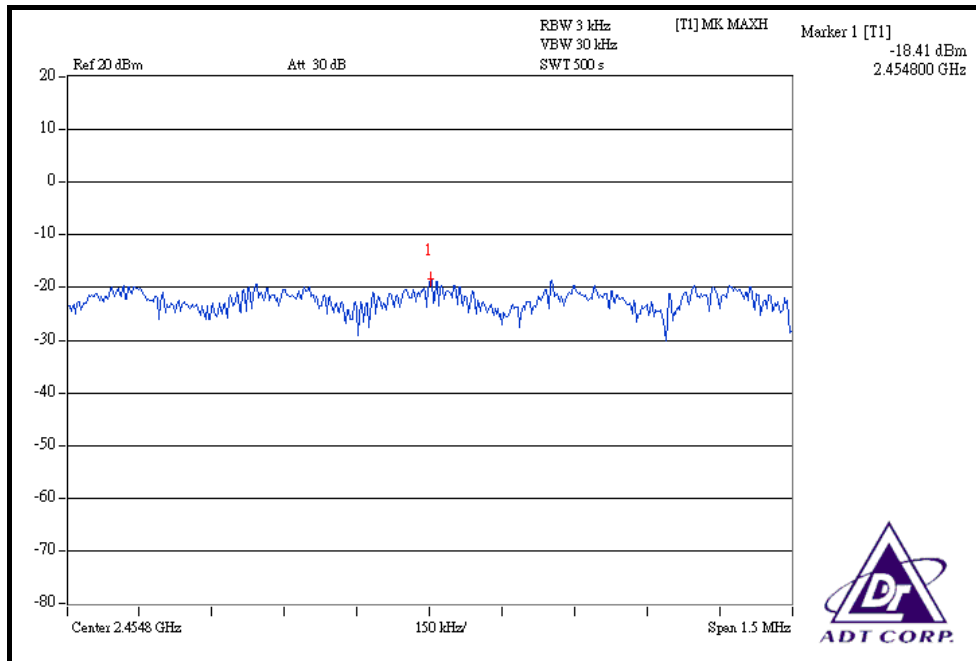



DRAFT 802.11n (20MHz) OFDM MODULATION

MODULATION TYPE	BPSK	TRANSFER RATE	7.2Mbps
INPUT POWER (SYSTEM)	120Vac, 60 Hz	ENVIRONMENTAL CONDITIONS	25deg.C, 65%RH, 991hPa
TESTED BY	Brad Wu		

CHANNEL	CHANNEL FREQUENCY (MHz)	RF POWER LEVEL IN 3kHz BW (dBm)		TOTAL POWER DENSITY (mW)	TOTAL POWER DENSITY (dBm)	MAX. LIMIT (dBm)	PASS / FAIL
		CHAIN 0	CHAIN 1				
1	2412	-16.78	-16.17	0.045	-13.45	8	PASS
6	2437	-16.92	-16.31	0.044	-13.59	8	PASS
11	2462	-16.83	-15.97	0.046	-13.37	8	PASS

FOR CHAIN 0: CH 1

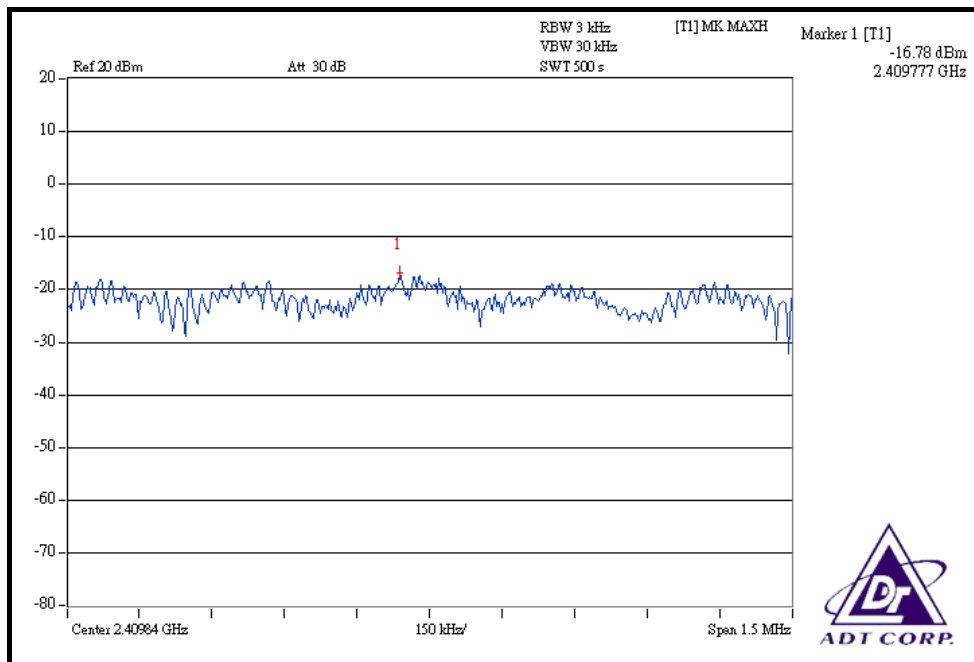

CH 6

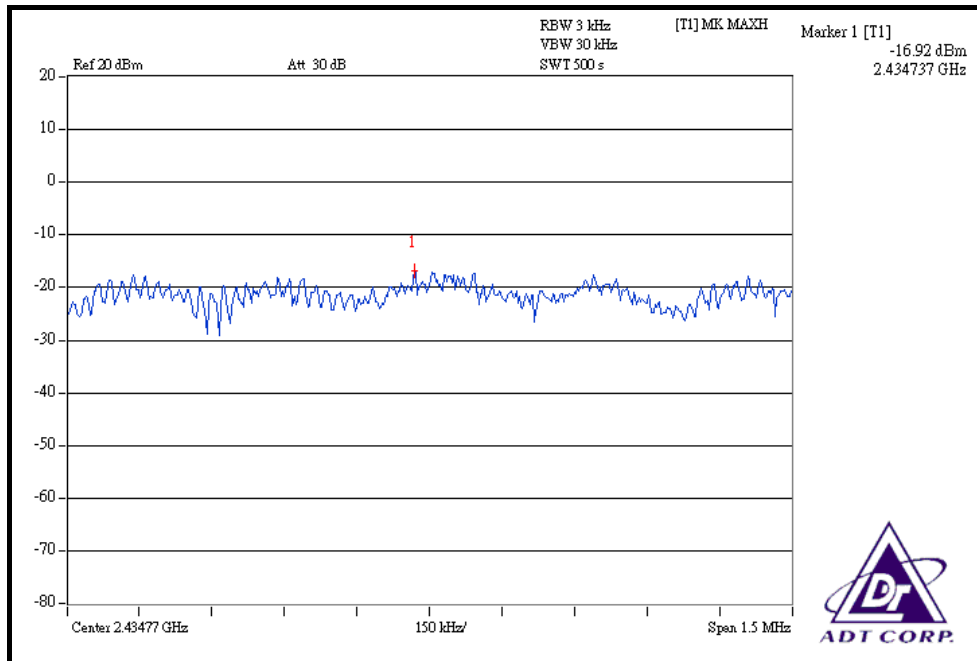

CH 11

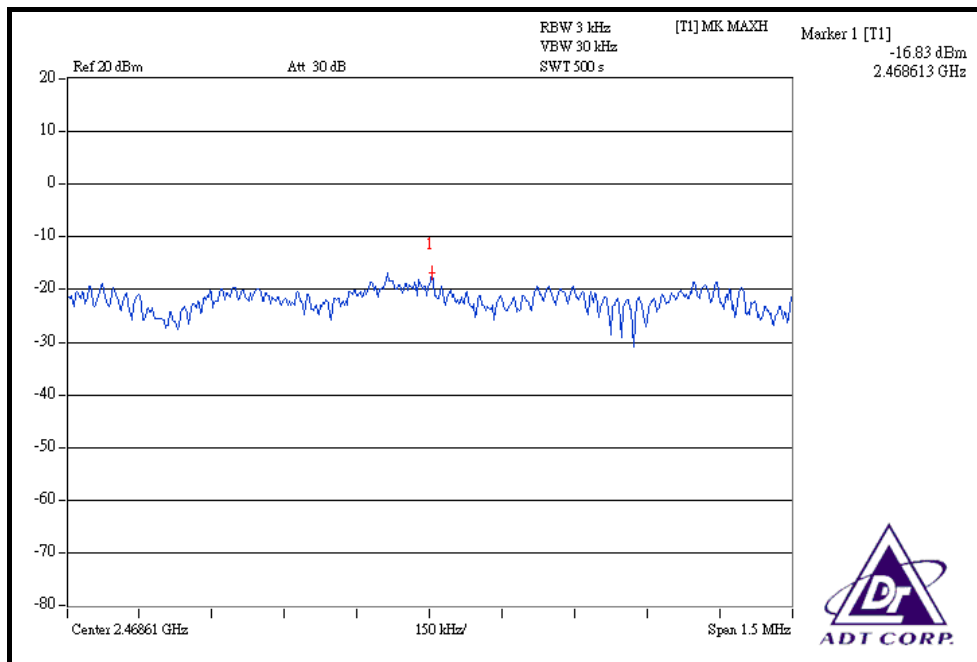

CH 11

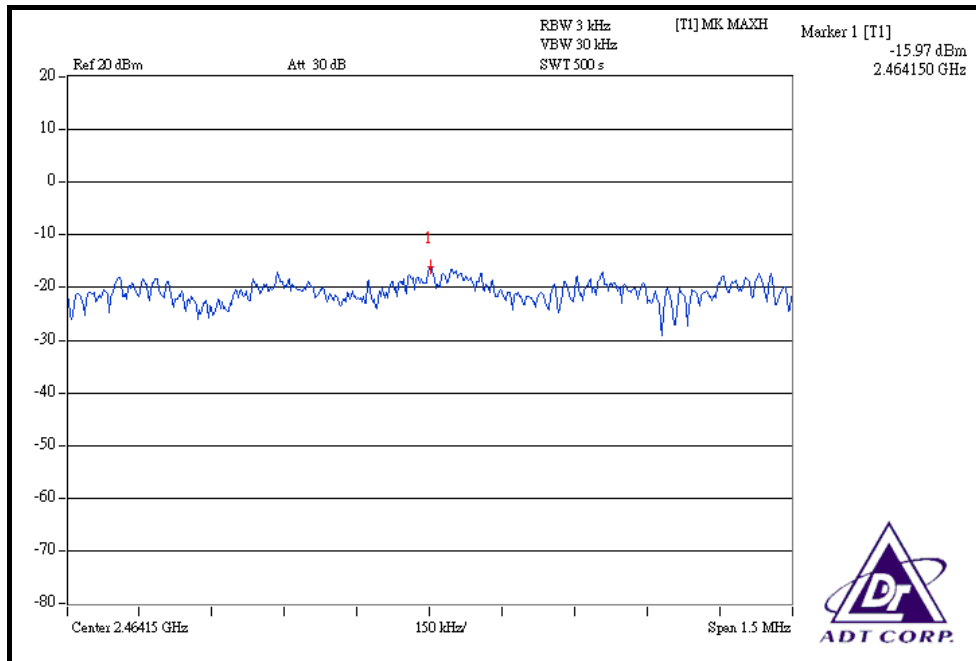



DRAFT 802.11n (40MHz) OFDM MODULATION

MODULATION TYPE	BPSK	TRANSFER RATE	15Mbps
INPUT POWER (SYSTEM)	120Vac, 60 Hz	ENVIRONMENTAL CONDITIONS	25deg.C, 65%RH, 991hPa
TESTED BY	Brad Wu		

CHANNEL	CHANNEL FREQUENCY (MHz)	RF POWER LEVEL IN 3kHz BW (dBm)		TOTAL POWER DENSITY (mW)	TOTAL POWER DENSITY (dBm)	MAX. LIMIT (dBm)	PASS / FAIL
		CHAIN 0	CHAIN 1				
1	2422	-17.60	-17.83	0.034	-14.70	8	PASS
4	2437	-17.63	-17.68	0.034	-14.64	8	PASS
7	2452	-17.46	-17.76	0.035	-14.60	8	PASS

FOR CHAIN 0: CH 1

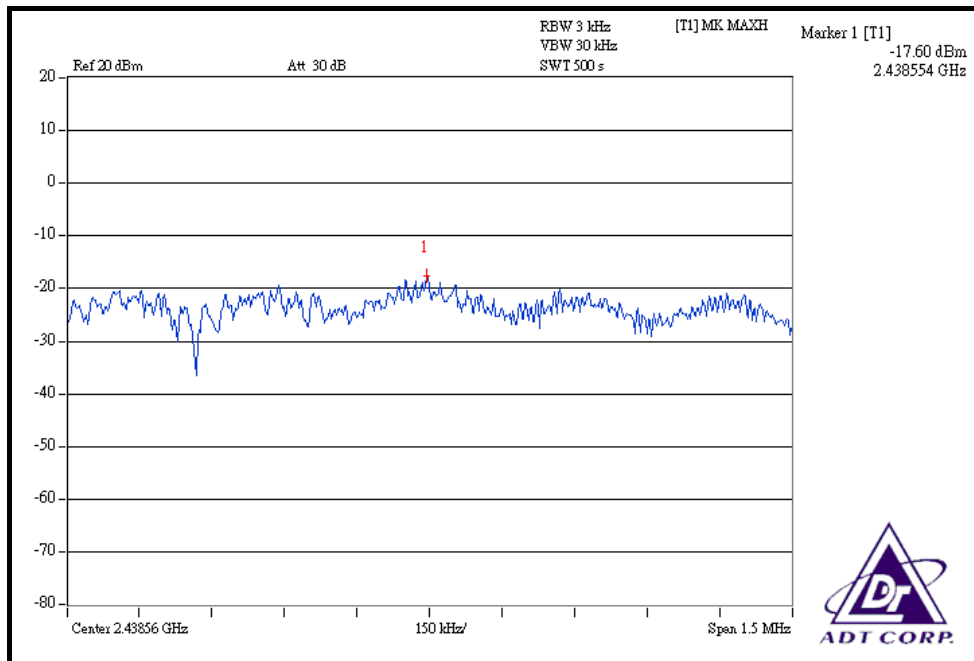

CH 4

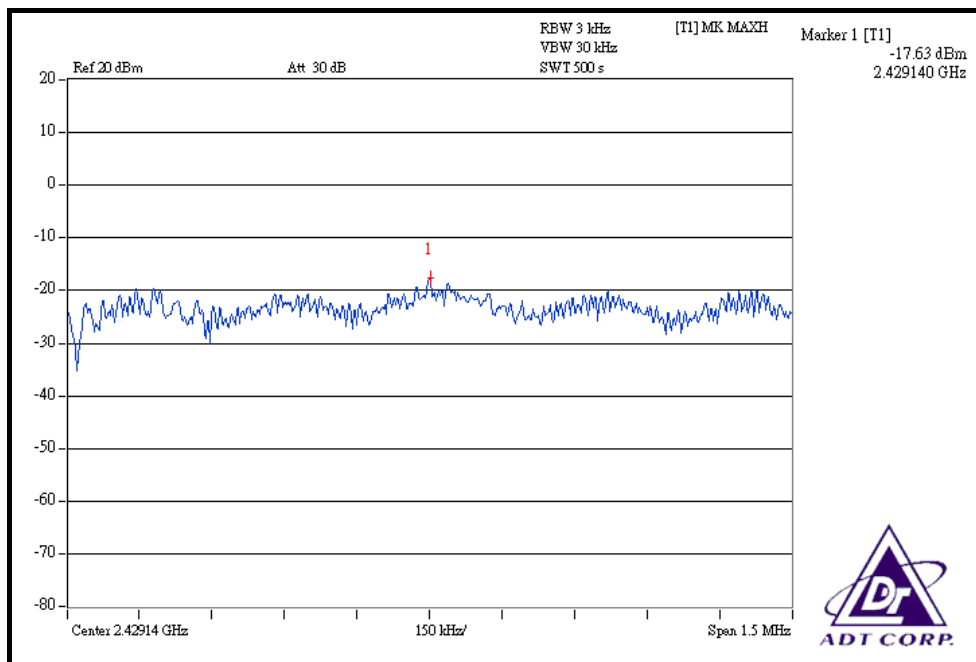

CH 7

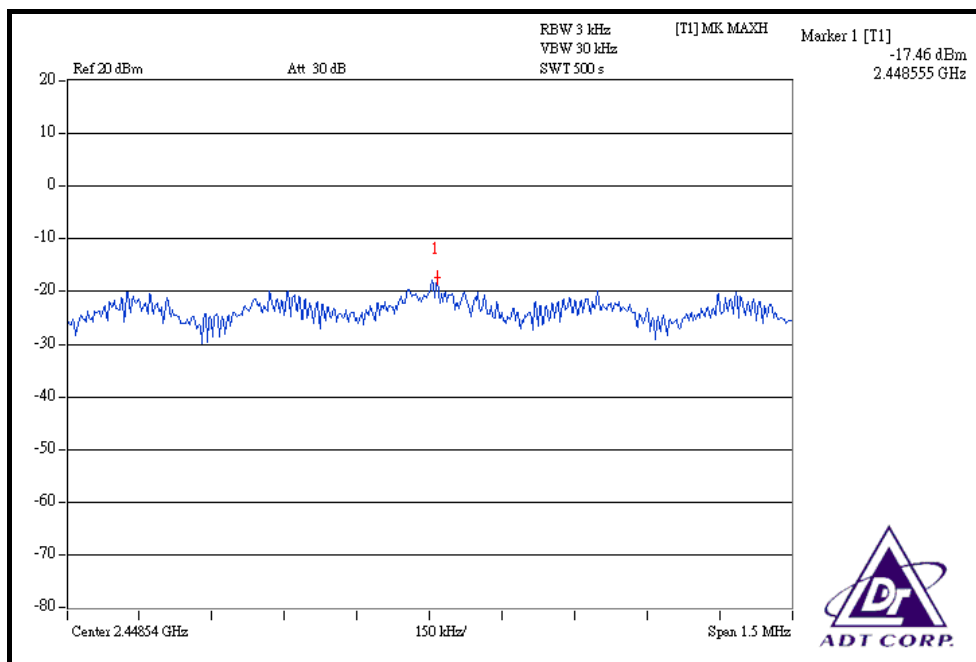

FOR CHAIN 1: CH 1

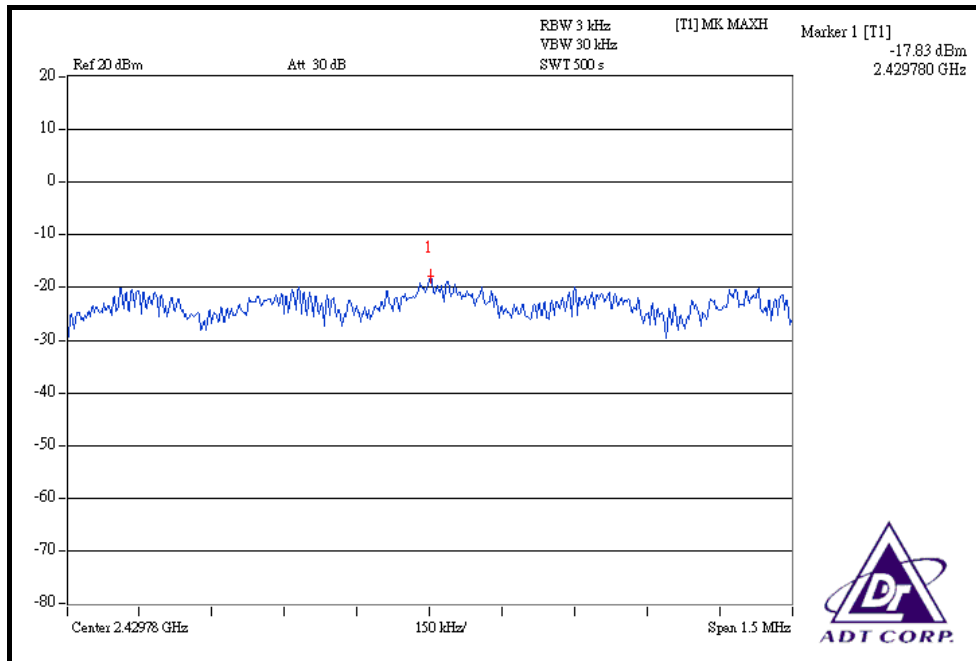

CH 4

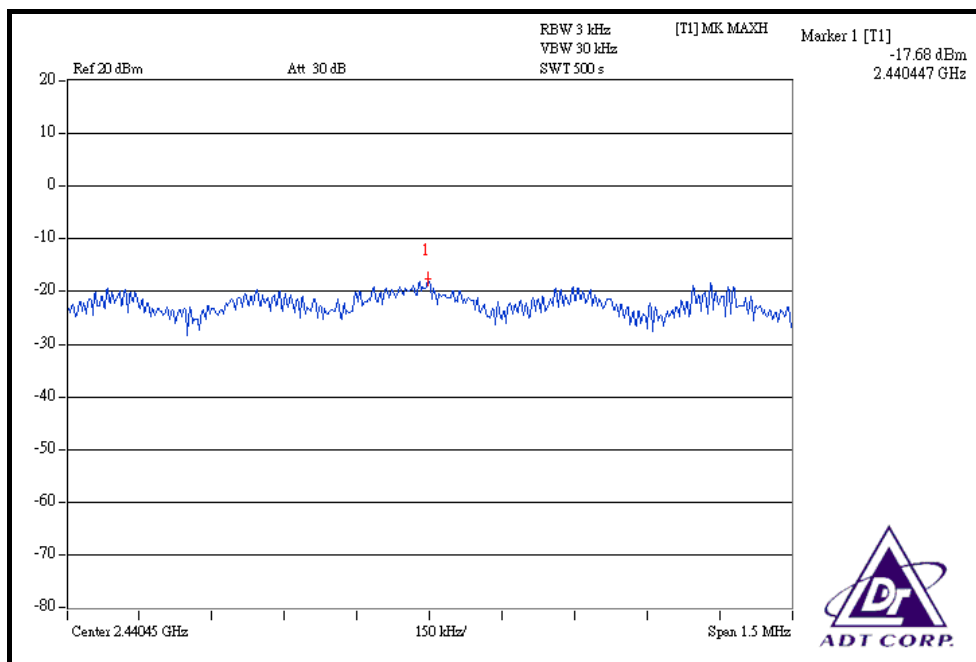

CH 7

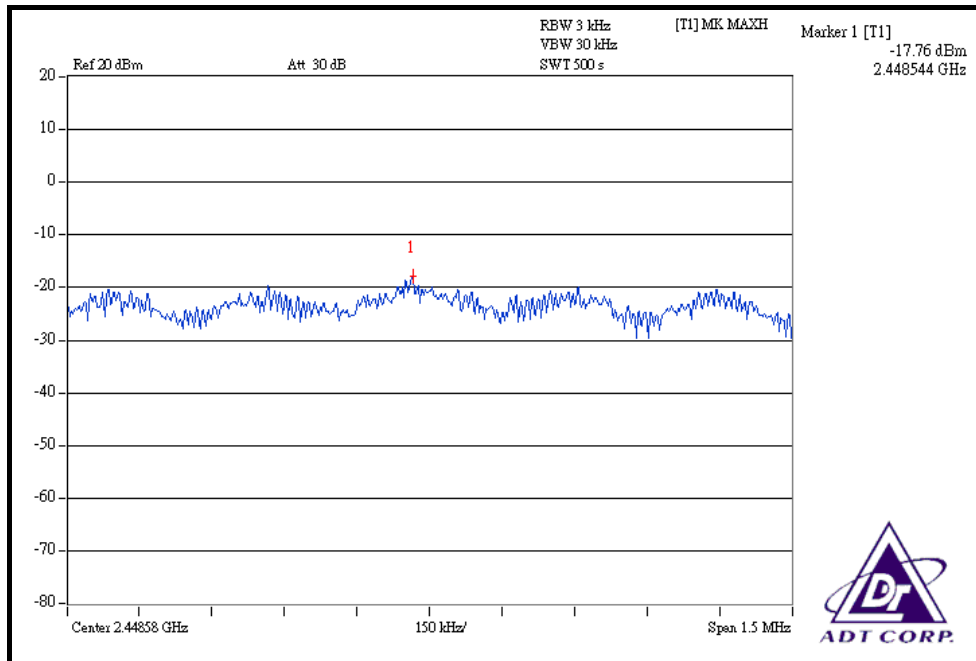



4.6 BAND EDGES MEASUREMENT

4.6.1 LIMITS OF BAND EDGES MEASUREMENT

Below –20dB of the highest emission level of operating band (in 100kHz Resolution Bandwidth).

4.6.2 TEST INSTRUMENTS

DESCRIPTION & MANUFACTURER	MODEL NO.	SERIAL NO.	CALIBRATED UNTIL
FOR CONDUCTED MEASUREMENT			
R&S SPECTRUM ANALYZER	FSP40	100040	Jun. 28, 2008
FOR RADIATED MEASUREMENT			
Test Receiver ROHDE & SCHWARZ	ESI7	838496/016	Dec. 25, 2008
Spectrum Analyzer ROHDE & SCHWARZ	FSP40	100039	Dec. 02, 2008
BILOG Antenna SCHWARZBECK	VULB9168	9168-155	Jan. 03, 2009
HORN Antenna SCHWARZBECK	BBHA 9120D	9120D-405	Dec. 17, 2008
HORN Antenna SCHWARZBECK	BBHA 9170	BBHA9170242	Jan. 06, 2009
Preamplifier Agilent	8449B	3008A01910	Sep. 19, 2008
Preamplifier Agilent	8447D	2944A10634	Dec. 12, 2008
RF signal cable HUBER+SUHNNER	SUCOFLEX 104	274397/4	Nov. 07, 2008
RF signal cable HUBER+SUHNNER	SUCOFLEX 104	283401/4	Nov. 07, 2008
Software ADT.	ADT_Radiated_V7.6	NA	NA
Antenna Tower inn-co GmbH	MA 4000	010303	NA
Antenna Tower Controller inn-co GmbH	CO2000	019303	NA
Turn Table ADT.	TT100.	TT93021704	NA
Turn Table Controller ADT.	SC100.	SC93021704	NA

NOTE: The calibration interval of the above test instruments is 12 months and the calibrations are traceable to NML/ROC and NIST/USA.

4.6.3 TEST PROCEDURE

FOR CONDUCTED MEASUREMENT

The transmitter output was connected to the spectrum analyzer via a low lose cable. Set both RBW and VBW of spectrum analyzer to 100kHz and 300kHz with suitable frequency span including 100MHz bandwidth from band edge. The band edges was measured and recorded.

The spectrum plots (Peak RBW = 100kHz, VBW = 300kHz; Average RBW = 1MHz, VBW = 10Hz) are attached on the following pages.

FOR RADIATED MEASUREMENT

- a. The EUT was placed on the top of a rotating table 0.8 meters above the ground at a 3 meter semi-anechoic chamber. The table was rotated 360 degrees to determine the position of the highest radiation.
- b. The EUT was set 3 meters away from the interference-receiving antenna, which was mounted on the top of a variable-height antenna tower.
- c. The antenna is a broadband antenna, and its height is varied from one meter to four meters above the ground to determine the maximum value of the field strength. Both horizontal and vertical polarizations of the antenna are set to make the measurement.
- d. For each suspected emission, the EUT was arranged to its worst case and then the antenna was tuned to heights from 1 meter to 4 meters and the rotatable table was turned from 0 degrees to 360 degrees to find the maximum reading.
- e. Set both RBW and VBW of spectrum analyzer to 100kHz with suitable frequency span including 100MHz bandwidth from band edge. The band edges was measured and recorded.

The spectrum plots (Peak RBW = 100kHz, VBW = 300kHz; Average RBW = 1MHz, VBW = 10Hz)

4.6.4 DEVIATION FROM TEST STANDARD

No deviation.

4.6.5 EUT OPERATING CONDITION

Same as Item 4.3.6.

4.6.6 TEST RESULTS

The spectrum plots are attached on the following 24 images. D1 line indicates the highest level, and D2 line indicates the 20dB offset below D1. It shows compliance with the requirement in part 15.247(d).

802.11b DSSS MODULATION

NOTE 1: The band edge emission plot on the next page shows 48.28dBc between carrier maximum power and local maximum emission in restrict band (2.38660GHz). The emission of carrier strength list in the test result of channel 1 at the item 4.2.7 is 104.51dBuV/m (Peak), so the maximum field strength in restrict band is $104.51 - 48.28 = 56.23$ dBuV/m which is under 74dBuV/m limit.

The band edge emission plot on the next page shows 53.90dBc between carrier maximum power and local maximum emission in restrict band (2.38640GHz). The emission of carrier strength list in the test result of channel 1 at the item 4.2.7 is 100.08dBuV/m (Peak), so the maximum field strength in restrict band is $100.08 - 53.90 = 46.18$ dBuV/m which is under 54dBuV/m limit.

NOTE 2: The band edge emission plot on the next second page shows 48.98dBc between carrier maximum power and local maximum emission in restrict band (2.48780GHz). The emission of carrier strength list in the test result of channel 11 at the item 4.2.7 is 106.34dBuV/m (Peak), so the maximum field strength in restrict band is $106.34 - 48.98 = 57.36$ dBuV/m which is under 74dBuV/m limit.

The band edge emission plot on the next third page shows 53.99dBc between carrier maximum power and local maximum emission in restrict band (2.48780GHz). The emission of carrier strength list in the test result of channel 11 at the item 4.2.7 is 101.88dBuV/m (Peak), so the maximum field strength in restrict band is $101.88 - 53.99 = 47.89$ dBuV/m which is under 54dBuV/m limit.

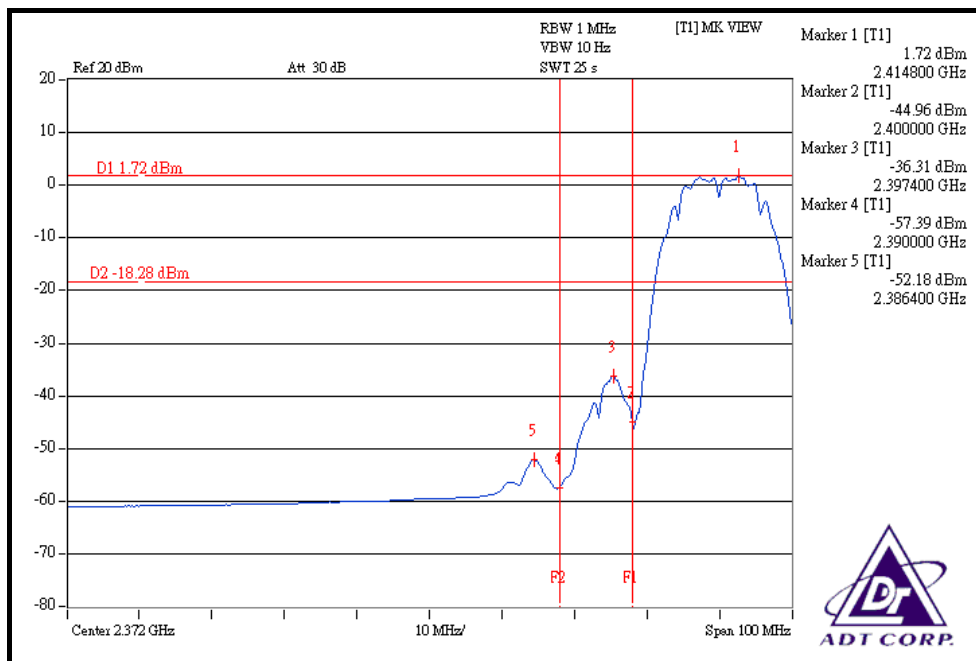
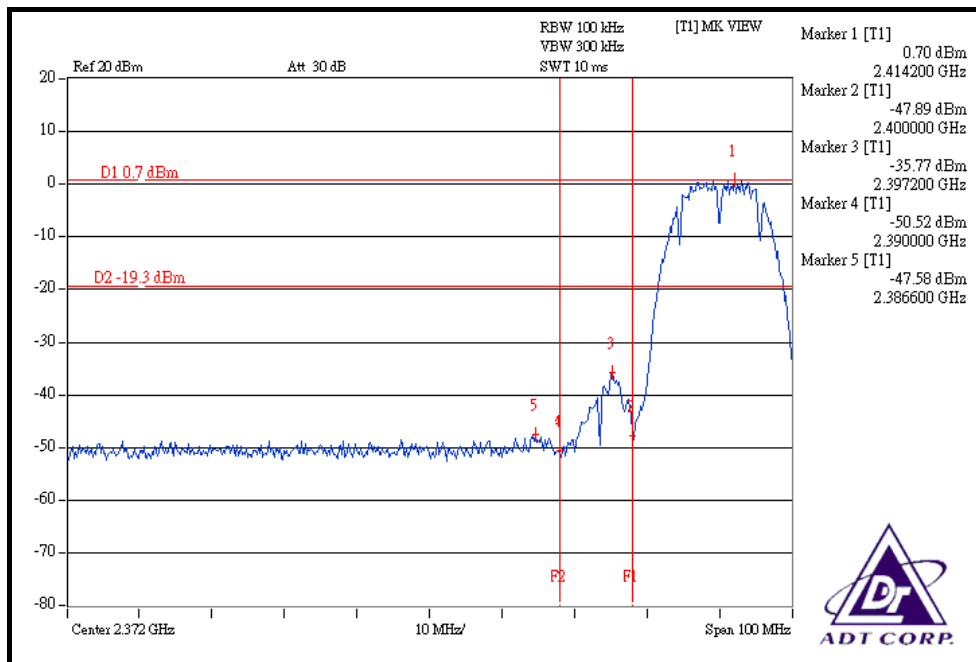

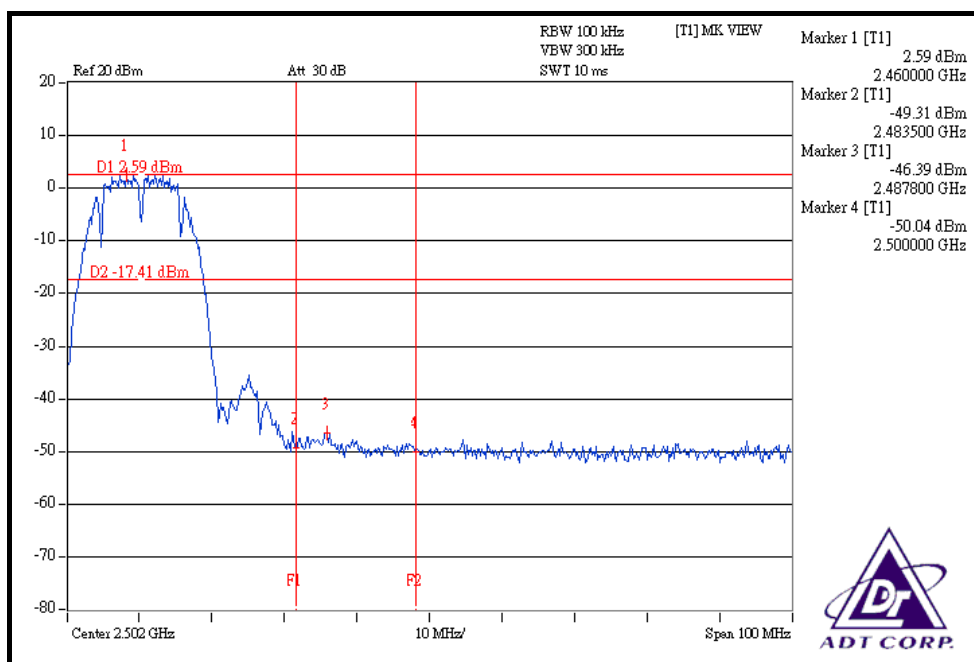
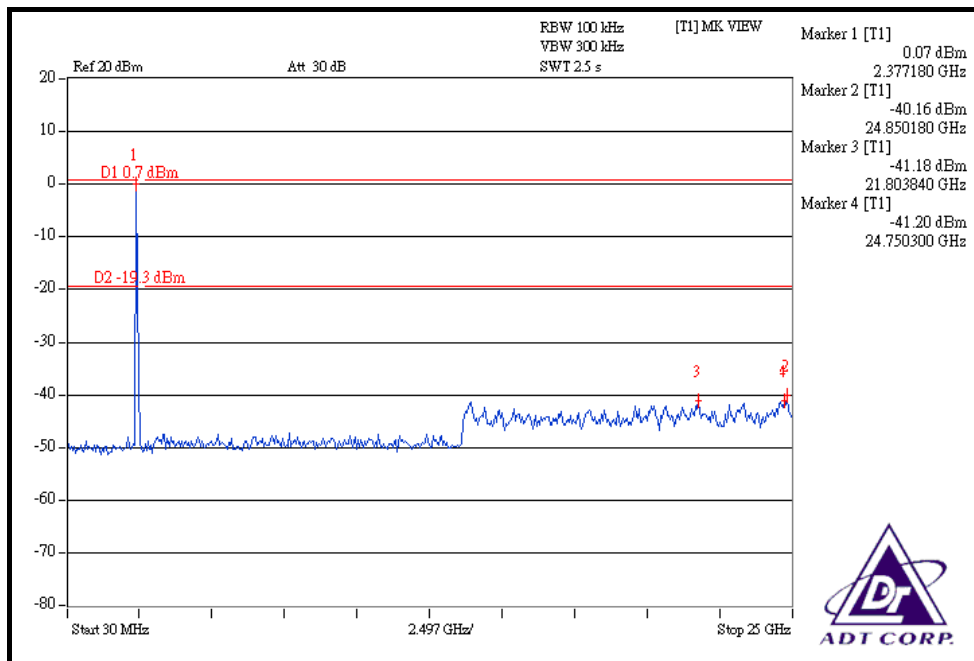

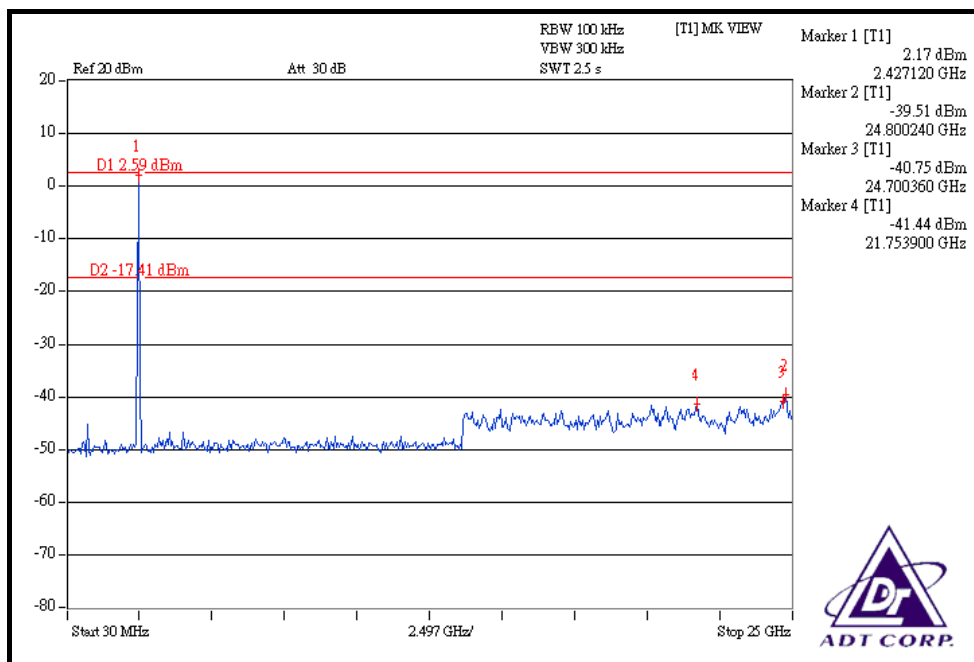
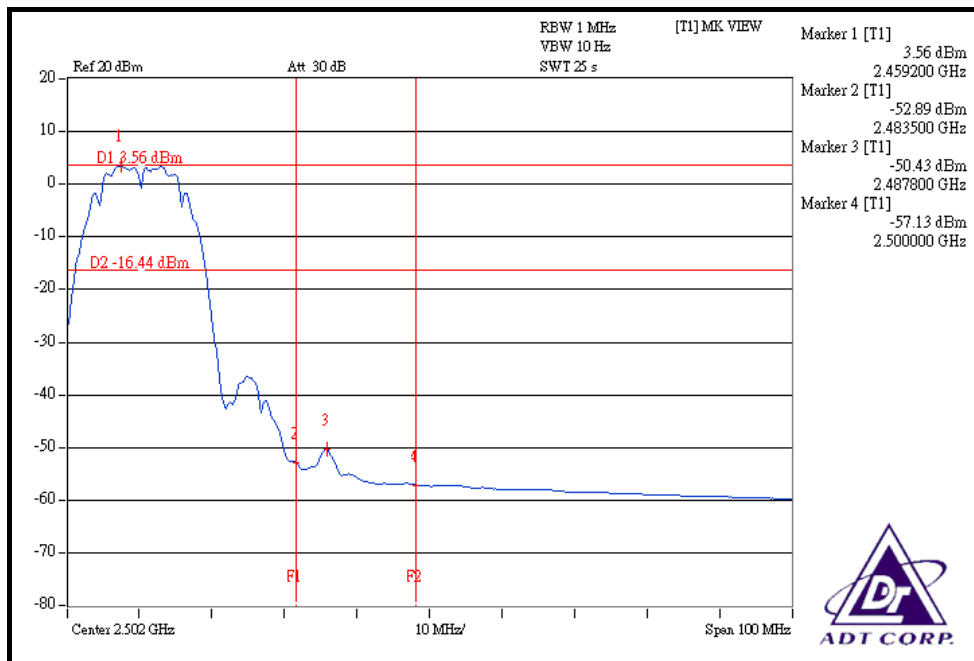

802.11g OFDM MODULATION

NOTE 1: The band edge emission plot on the next page shows 41.94dBc between carrier maximum power and local maximum emission in restrict band (2.38940GHz). The emission of carrier strength list in the test result of channel 1 at the item 4.2.7 is 105.52dBuV/m (Peak), so the maximum field strength in restrict band is $105.52 - 41.94 = 63.58$ dBuV/m which is under 74dBuV/m limit.

The band edge emission plot on the next page shows 49.52dBc between carrier maximum power and local maximum emission in restrict band (2.39000GHz). The emission of carrier strength list in the test result of channel 1 at the item 4.2.7 is 95.66dBuV/m (Peak), so the maximum field strength in restrict band is $95.66 - 49.52 = 46.14$ dBuV/m which is under 54dBuV/m limit.

NOTE 2: The band edge emission plot on the next second page shows 45.50dBc between carrier maximum power and local maximum emission in restrict band (2.48480GHz). The emission of carrier strength list in the test result of channel 11 at the item 4.2.7 is 105.42dBuV/m (Peak), so the maximum field strength in restrict band is $105.42 - 45.50 = 59.92$ dBuV/m which is under 74dBuV/m limit.

The band edge emission plot on the next third page shows 50.44dBc between carrier maximum power and local maximum emission in restrict band (2.48350GHz). The emission of carrier strength list in the test result of channel 11 at the item 4.2.7 is 95.36dBuV/m (Peak), so the maximum field strength in restrict band is $96.36 - 50.44 = 44.92$ dBuV/m which is under 54dBuV/m limit.

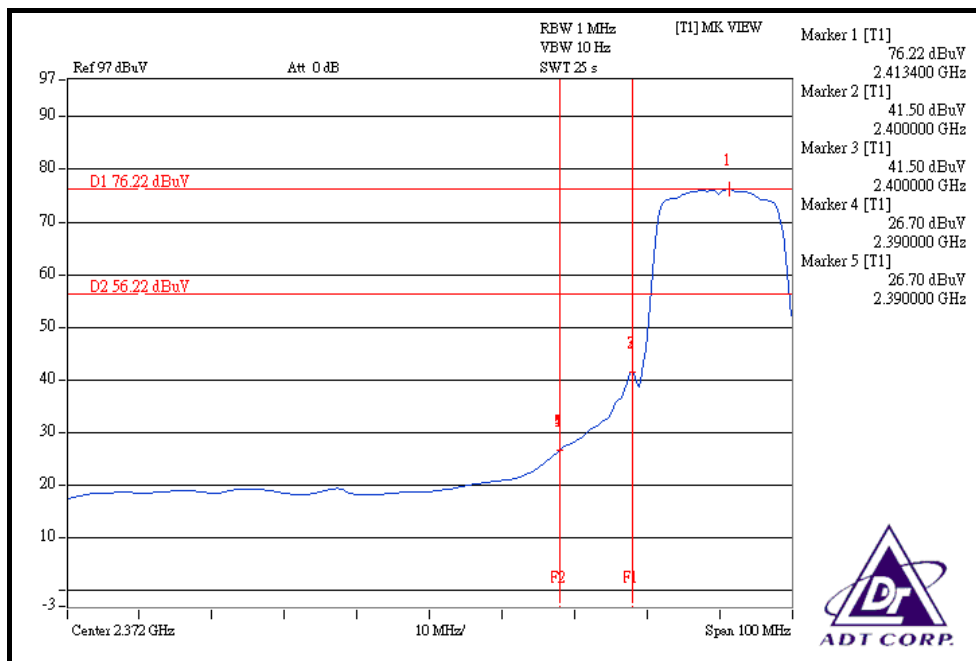
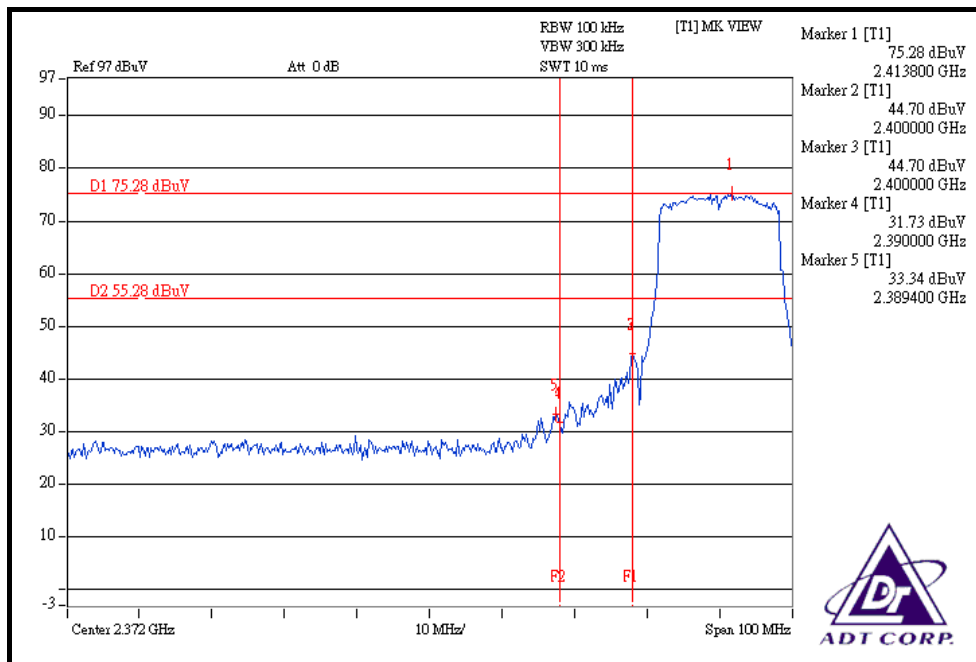

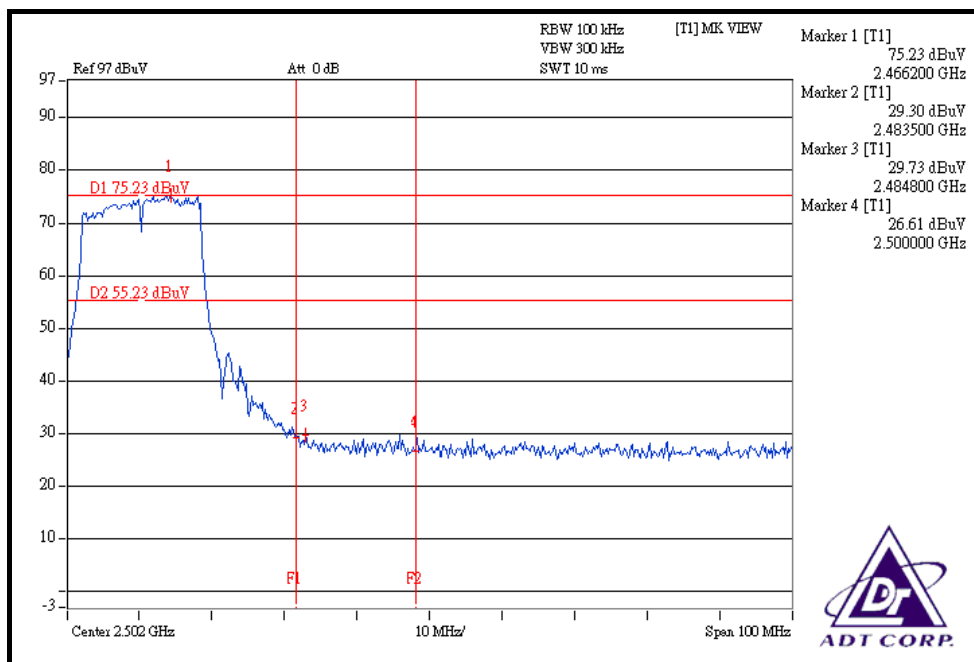
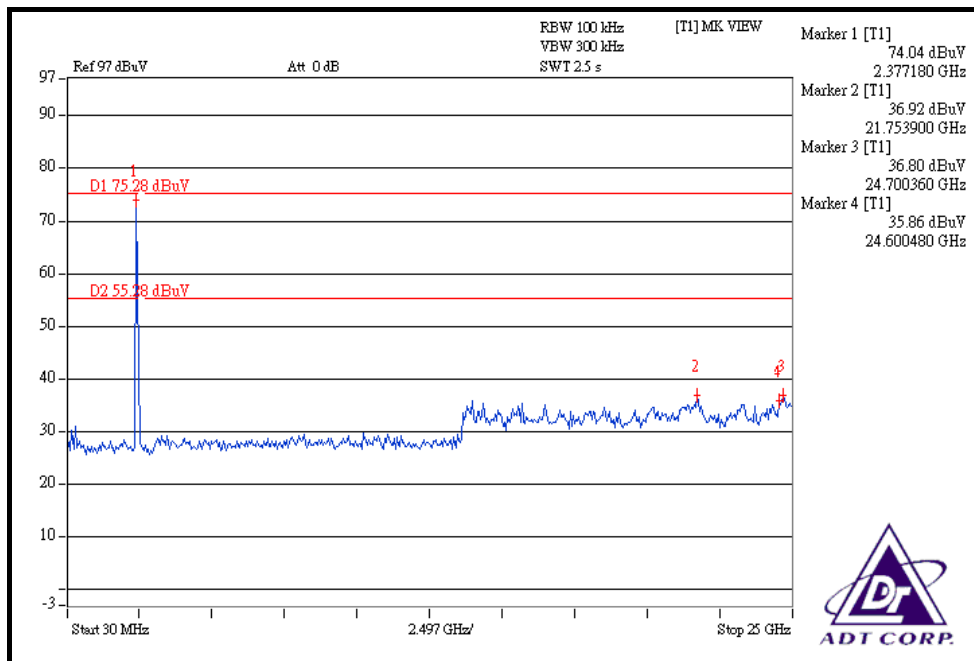

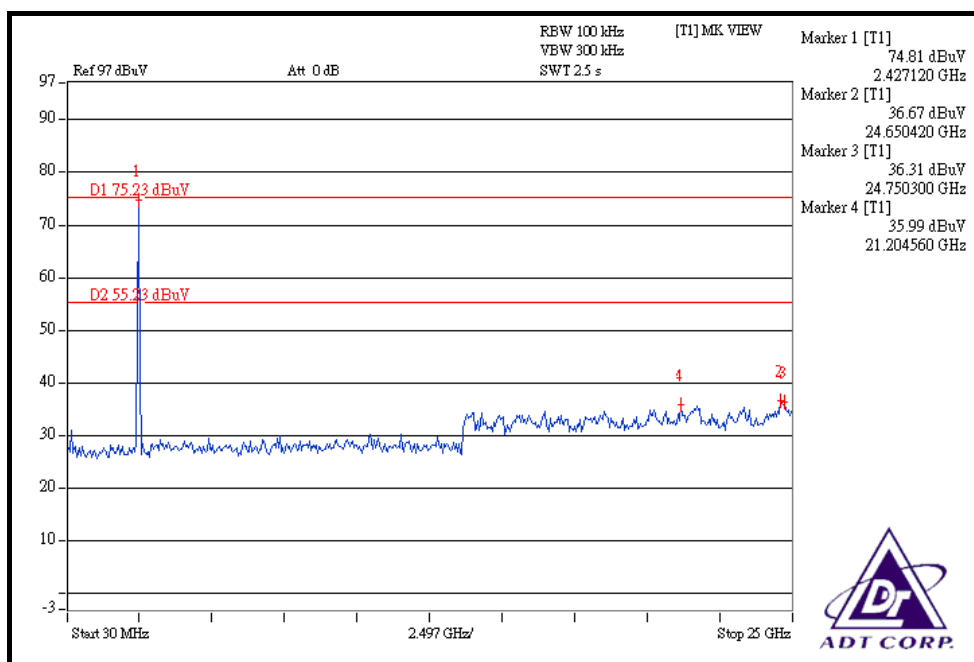
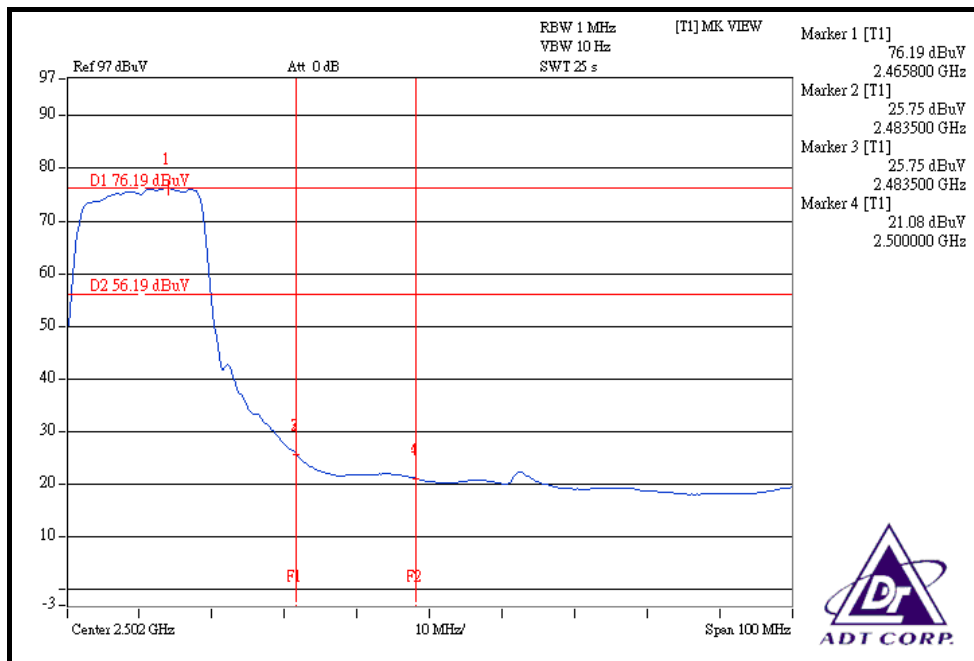

DRAFT 802.11n (20MHz) OFDM MODULATION

NOTE 1: The band edge emission plot on the next page shows 41.50dBc between carrier maximum power and local maximum emission in restrict band (2.38960GHz). The emission of carrier strength list in the test result of channel 1 at the item 4.2.7 is 104.46dBuV/m (Peak), so the maximum field strength in restrict band is $104.46 - 41.50 = 62.96$ dBuV/m which is under 74dBuV/m limit.

The band edge emission plot on the next page shows 46.47dBc between carrier maximum power and local maximum emission in restrict band (2.39000GHz). The emission of carrier strength list in the test result of channel 1 at the item 4.2.7 is 94.16dBuV/m (Peak), so the maximum field strength in restrict band is $94.16 - 46.47 = 47.69$ dBuV/m which is under 54dBuV/m limit.

NOTE 2: The band edge emission plot on the next second page shows 38.75dBc between carrier maximum power and local maximum emission in restrict band (2.48540GHz). The emission of carrier strength list in the test result of channel 11 at the item 4.2.7 is 105.06dBuV/m (Peak), so the maximum field strength in restrict band is $105.06 - 38.75 = 66.31$ dBuV/m which is under 74dBuV/m limit.

The band edge emission plot on the next third page shows 45.75dBc between carrier maximum power and local maximum emission in restrict band (2.48350GHz). The emission of carrier strength list in the test result of channel 11 at the item 4.2.7 is 94.94dBuV/m (Peak), so the maximum field strength in restrict band is $94.94 - 45.75 = 49.19$ dBuV/m which is under 54dBuV/m limit.

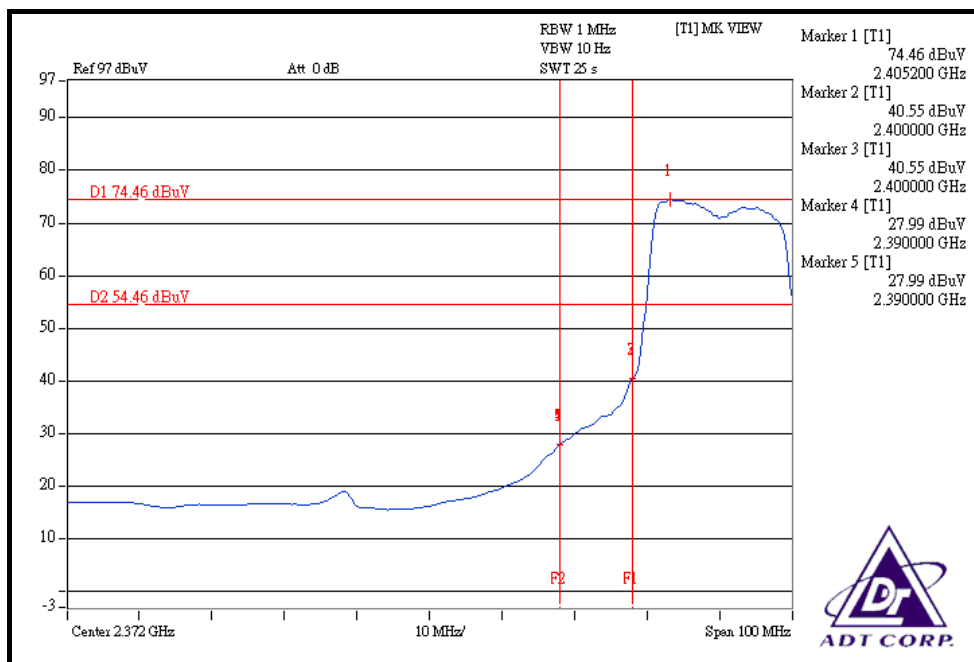
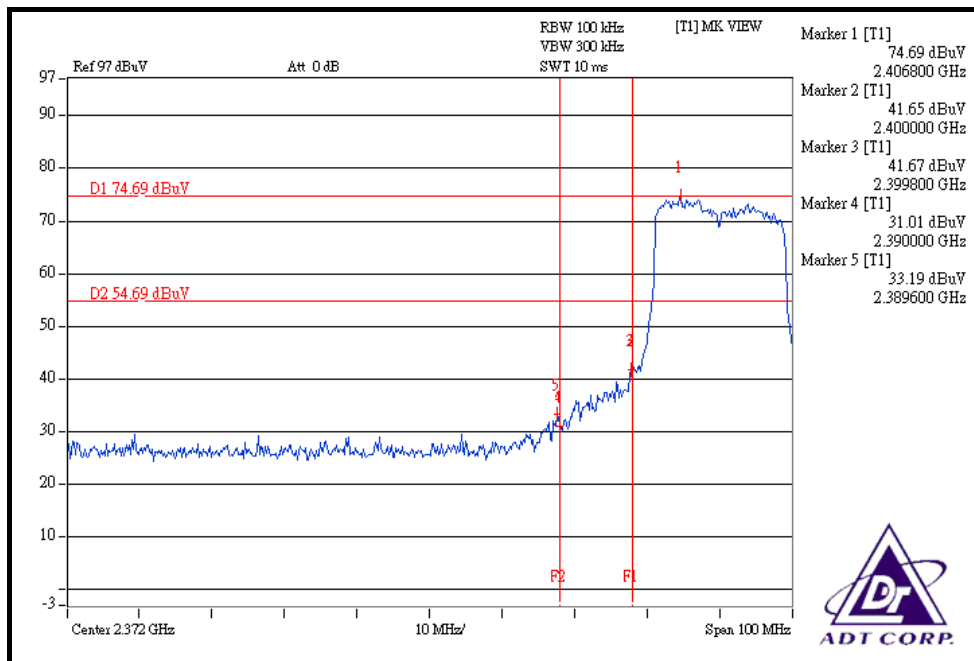

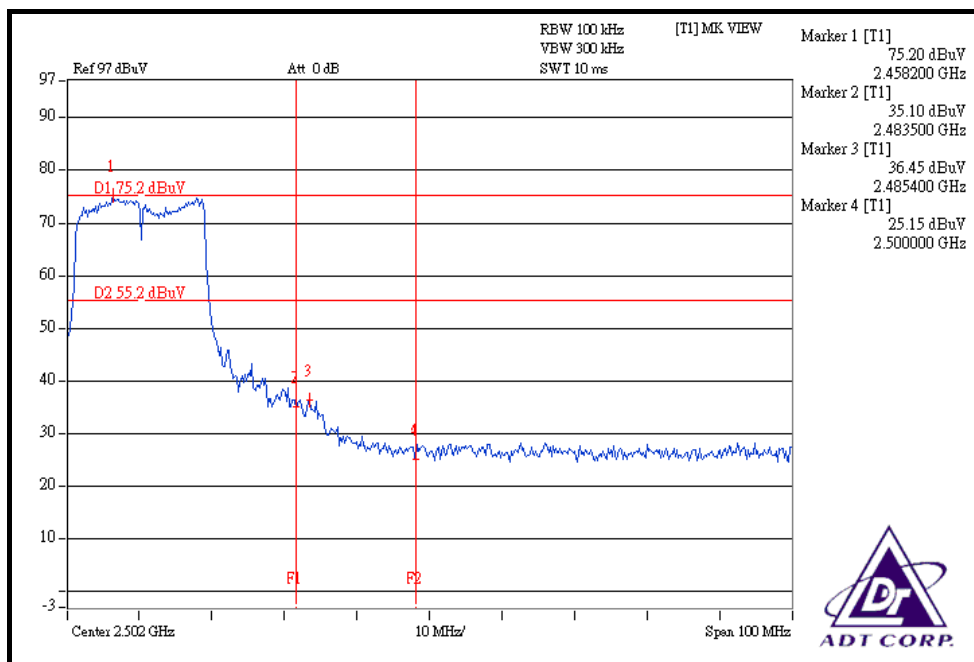
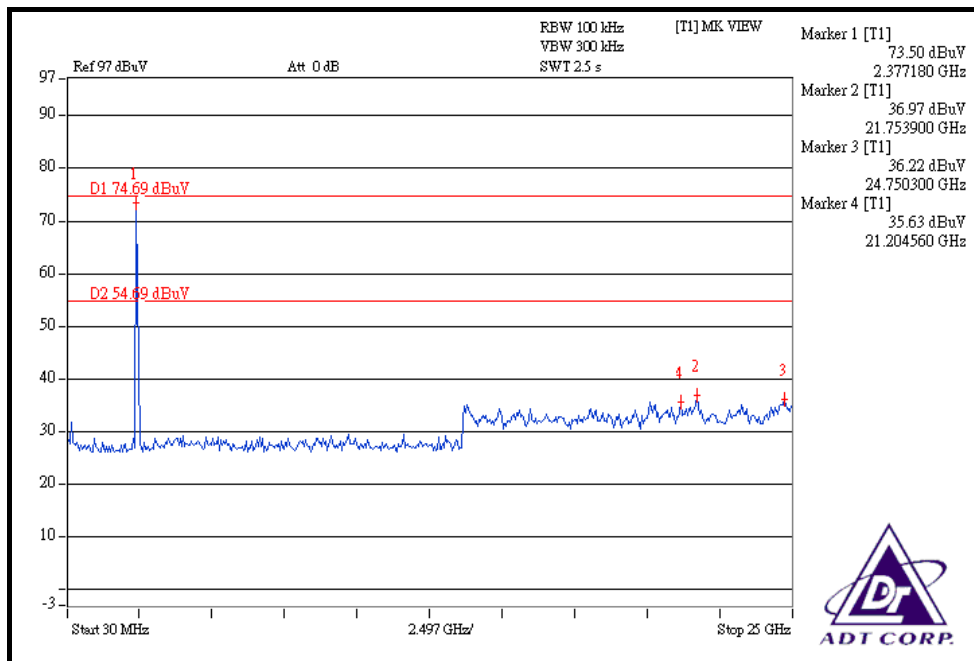

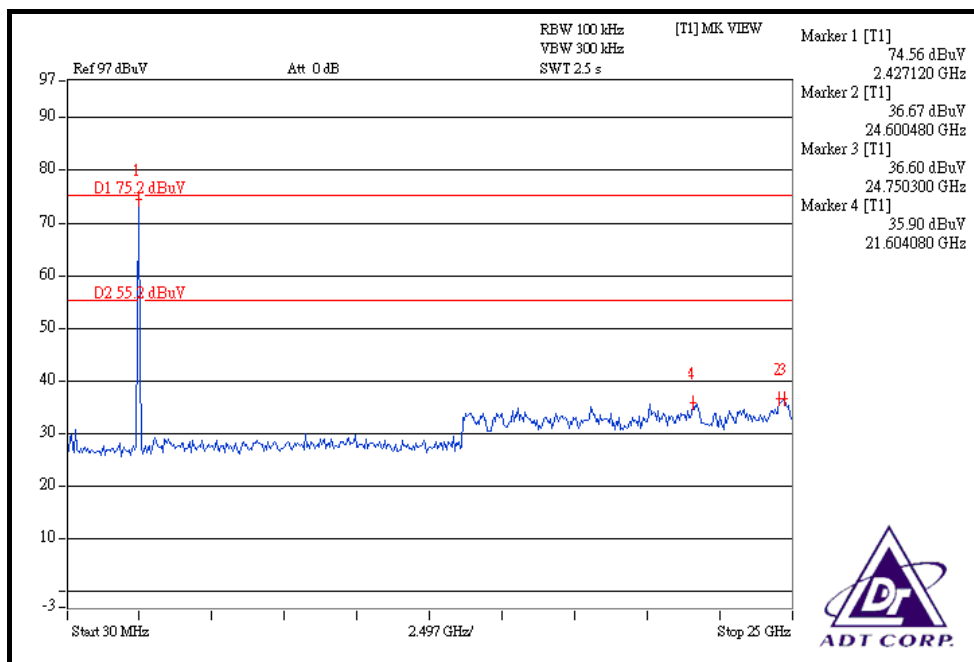
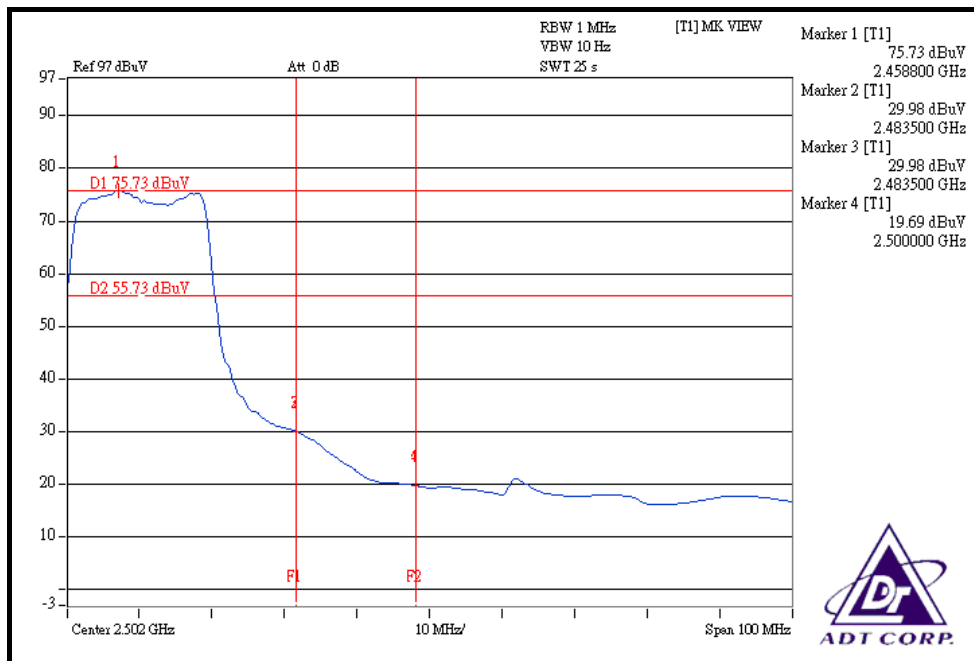

DRAFT 802.11n (40MHz) OFDM MODULATION

NOTE 1: The band edge emission plot on the next page shows 38.47dBc between carrier maximum power and local maximum emission in restrict band (2.38960GHz). The emission of carrier strength list in the test result of channel 1 at the item 4.2.7 is 102.72dBuV/m (Peak), so the maximum field strength in restrict band is $102.72 - 38.47 = 64.25$ dBuV/m which is under 74dBuV/m limit.

The band edge emission plot on the next page shows 43.28dBc between carrier maximum power and local maximum emission in restrict band (2.39000GHz). The emission of carrier strength list in the test result of channel 1 at the item 4.2.7 is 92.24dBuV/m (Peak), so the maximum field strength in restrict band is $92.24 - 43.28 = 48.96$ dBuV/m which is under 54dBuV/m limit.

NOTE 2: The band edge emission plot on the next second page shows 35.10dBc between carrier maximum power and local maximum emission in restrict band (2.48800GHz). The emission of carrier strength list in the test result of channel 11 at the item 4.2.7 is 102.81dBuV/m (Peak), so the maximum field strength in restrict band is $102.81 - 35.10 = 67.71$ dBuV/m which is under 74dBuV/m limit.

The band edge emission plot on the next third page shows 41.96dBc between carrier maximum power and local maximum emission in restrict band (2.48400GHz). The emission of carrier strength list in the test result of channel 11 at the item 4.2.7 is 92.30dBuV/m (Peak), so the maximum field strength in restrict band is $92.30 - 41.96 = 50.34$ dBuV/m which is under 54dBuV/m limit.

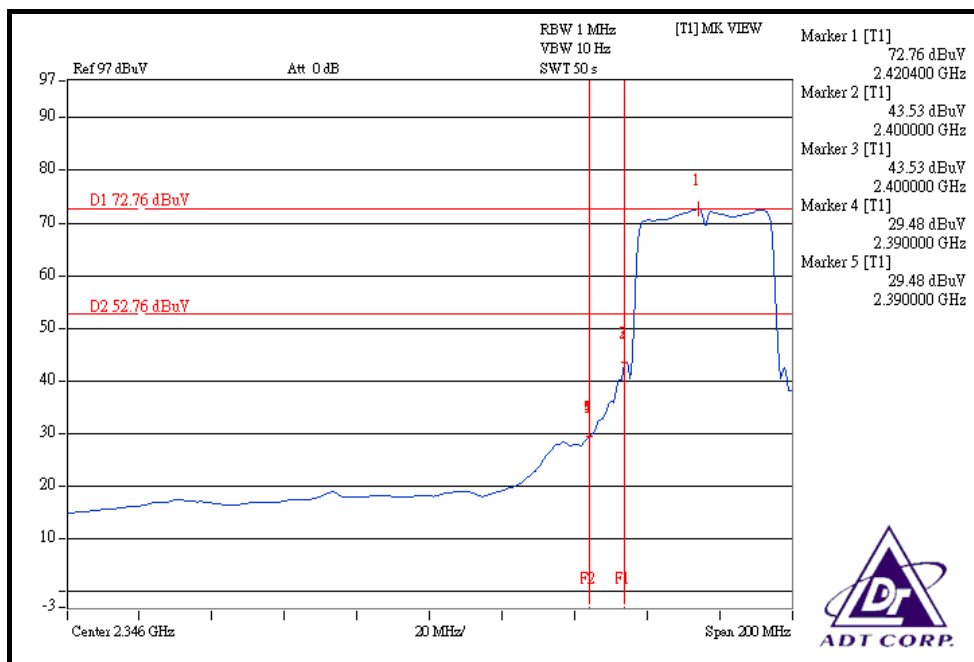
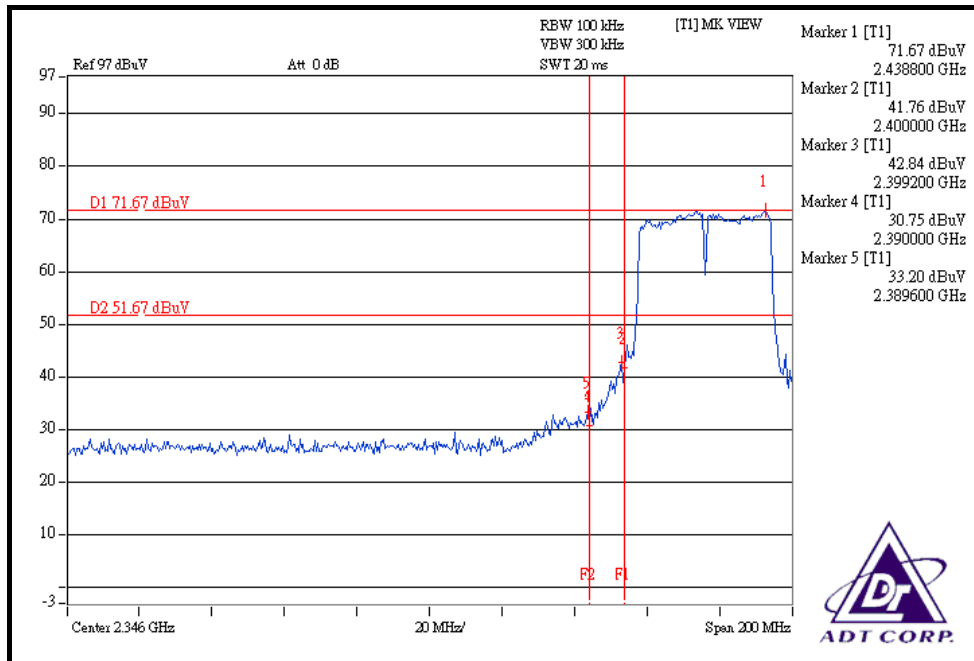

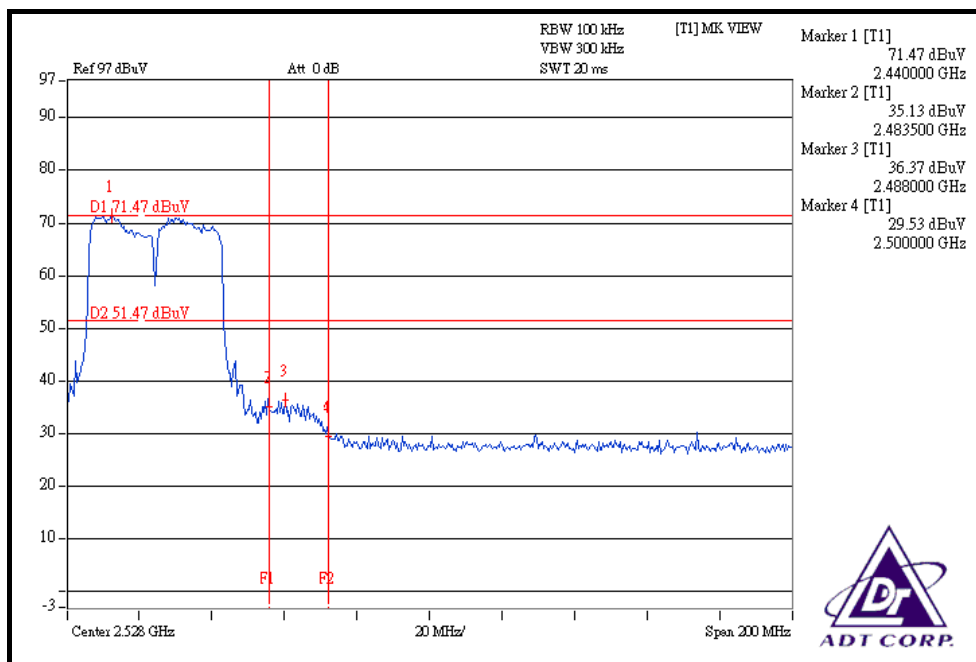
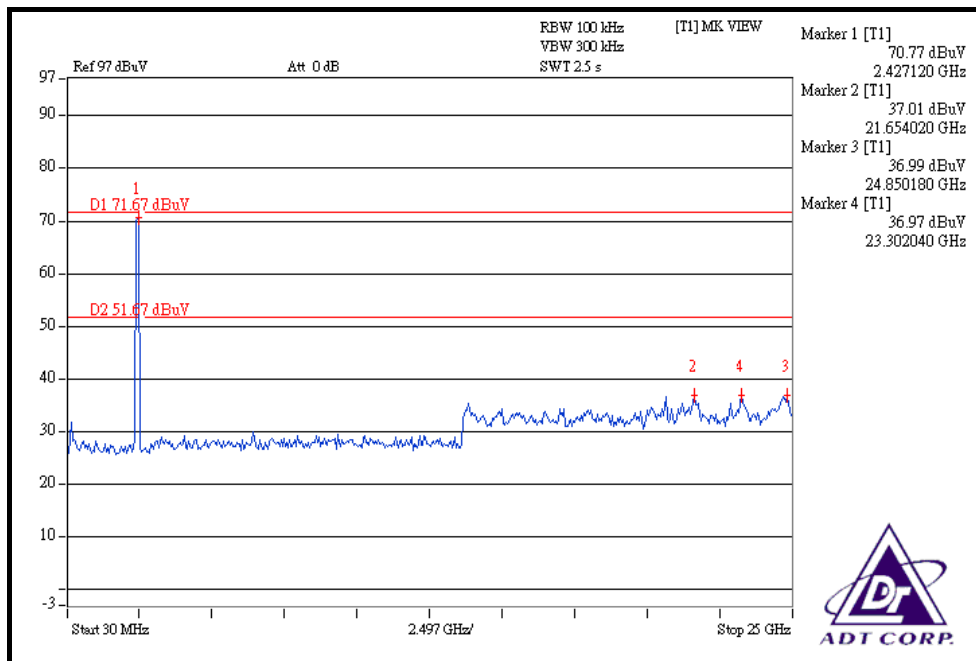

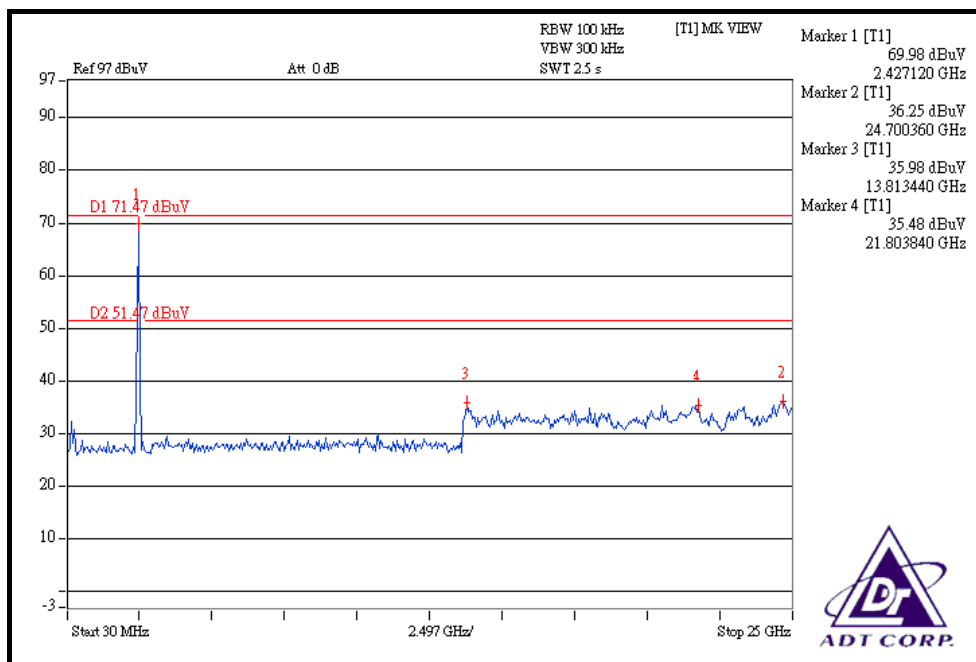
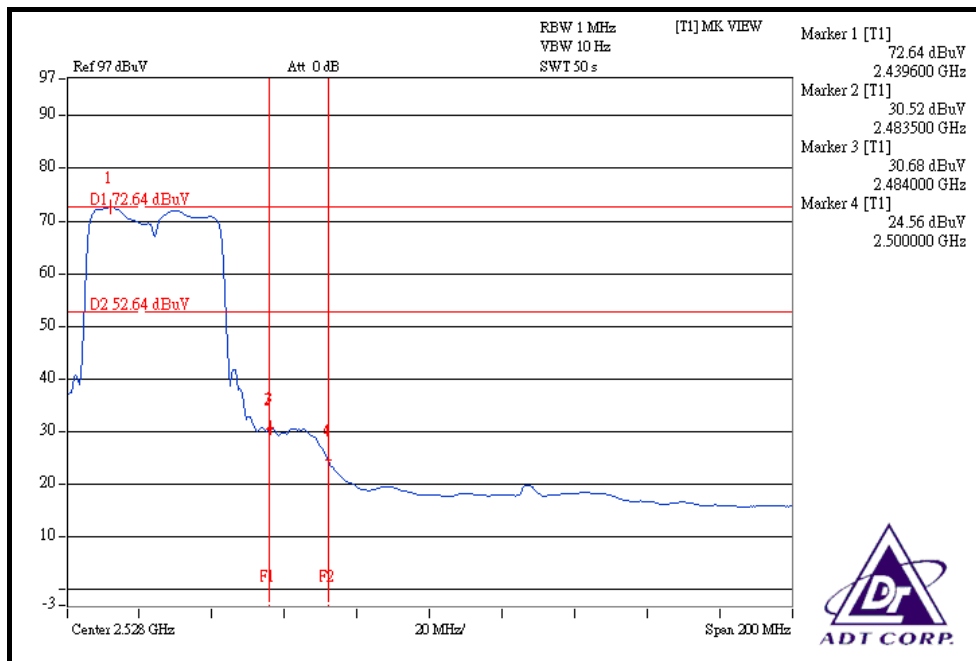



4.7 ANTENNA REQUIREMENT

4.7.1 STANDARD APPLICABLE

For intentional device, according to FCC 47 CFR Section 15.203, an intentional radiator shall be designed to ensure that no antenna other than that furnished by the responsible party shall be used with the device. And according to FCC 47 CFR Section 15.247 (b), if transmitting antennas of directional gain greater than 6dBi are used, the power shall be reduced by the amount in dB that the directional gain of the antenna exceeds 6dBi.

4.7.2 ANTENNA CONNECTED CONSTRUCTION

The antenna used in this product is Dish antenna without antenna connector. The maximum Gain of the antenna is 5dBi.



5. PHOTOGRAPHS OF THE TEST CONFIGURATION

Please refer to the attached file (Test Setup Photo).



6. INFORMATION ON THE TESTING LABORATORIES

We, ADT Corp., were founded in 1988 to provide our best service in EMC, Radio, Telecom and Safety consultation. Our laboratories are accredited and approved by the following approval agencies according to ISO/IEC 17025.

USA	FCC, UL, A2LA
Germany	TUV Rheinland
Japan	VCCI
Norway	NEMKO
Canada	INDUSTRY CANADA , CSA
R.O.C.	TAF, BSMI, NCC
Netherlands	Telefication
Singapore	GOST-ASIA(MOU)
Russia	CERTIS(MOU)

Copies of accreditation certificates of our laboratories obtained from approval agencies can be downloaded from our web site:

www.adt.com.tw/index.5/phtml. If you have any comments, please feel free to contact us at the following:

Linko EMC/RF Lab:

Tel: 886-2-26052180

Fax: 886-2-26051924

Hsin Chu EMC/RF Lab:

Tel: 886-3-5935343

Fax: 886-3-5935342

Hwa Ya EMC/RF/Safety Telecom Lab:

Tel: 886-3-3183232

Fax: 886-3-3185050

Web Site: www.adt.com.tw

The address and road map of all our labs can be found in our web site also.



7. APPENDIX A - MODIFICATIONS RECORDERS FOR ENGINEERING CHANGES TO THE EUT BY THE LAB

No any modifications are made to the EUT by the lab during the test.