

SJ 2.4GHz Transceiver Module TM01 & TM02

Integrators Installations Manual

1.Introduction

TM01 and TM02 Module consist of a 2.4GHz transceiver, Power Amplifier for 100mW output and a Low noise Amplifier for improved receiver sensitivity.

2.Specification

1)Operating Voltage

TM01: DC 3.3V

TM02: DC 3.3V

2)Operating Current

TX Mode: 160mA

RX Mode: 35mA

3)Frequency: 2400~2483.5MHz

4)RF output Power: Max 18.53dBm

5)Dimension

TM01: 32mm x 70mm x 5.7mm

TM02: 32.8mm x 60.05mm x 4.2mm

3.Antenna Spec

Appropriate FCC/CE/KC standards specified below 1.2dBi antenna is used.

-KMAP2440S2522T1: 2.4GHz Patch Antenna, 0dBi

-KMAP2440S2525T1: 2.4GHz Patch Antenna, 0.5dBi

-WPC.25A.07.0150C: 2.4GHz Patch Antenna, 0.5dBi

-C329-RF-001: 2.4GHz Dipole Antenna, 1.2dBi

-AT000067: 2.4GHz Dipole Antenna, 1.2dBi

4. Block Diagram

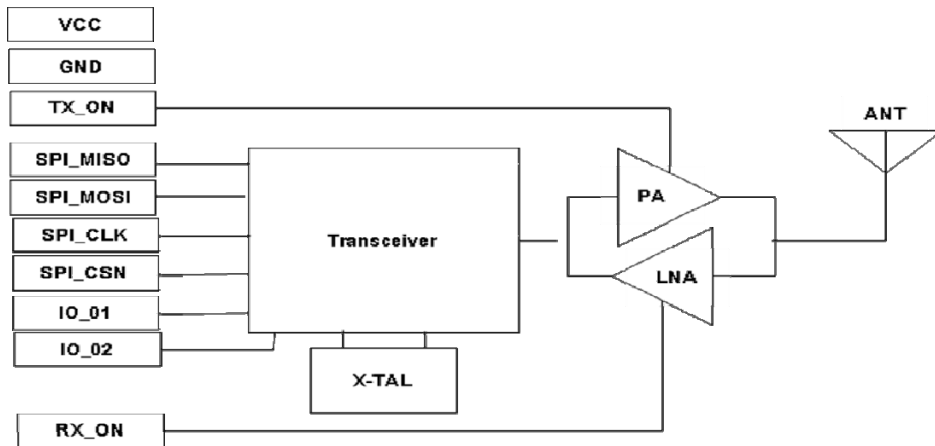

5. Application Schematic

TM02 is controlled by J1 or J2 and J3.

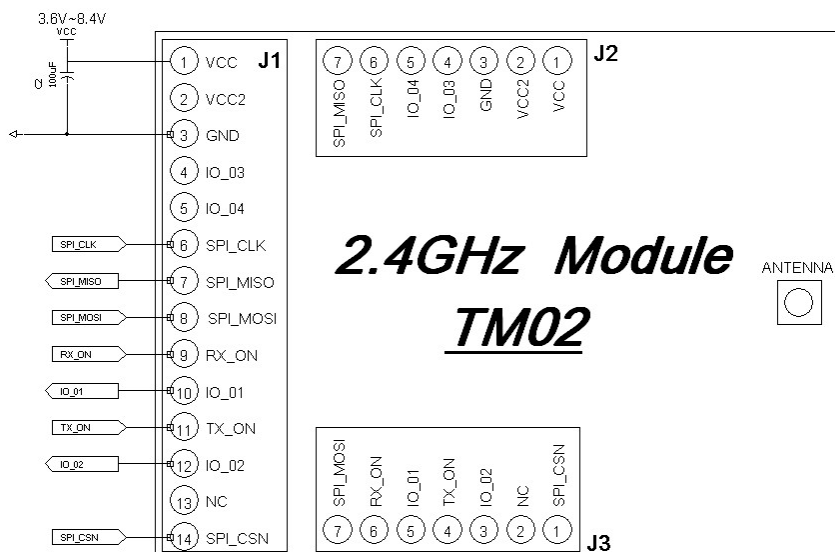
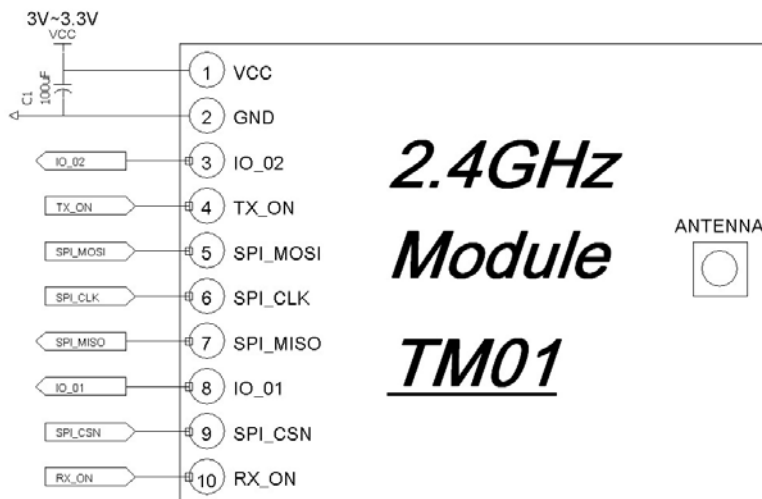

6.SPI Interface and Packet format

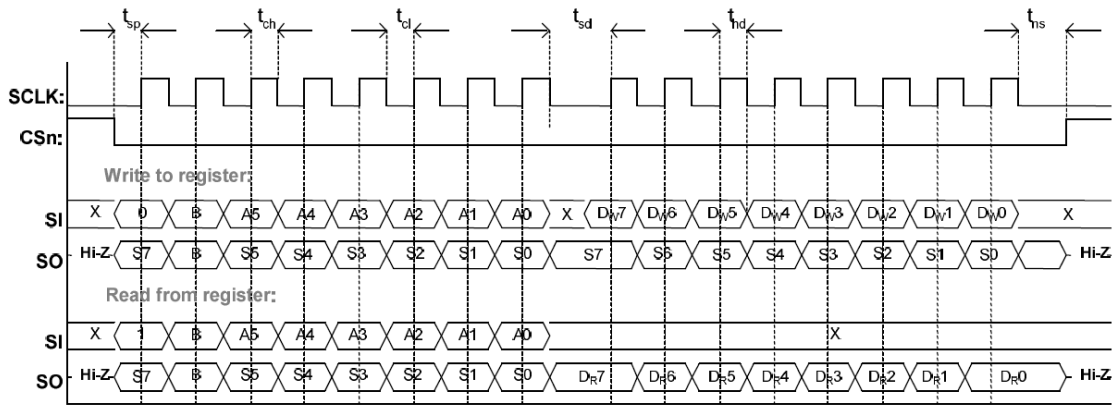

[Configuration Register Write and Read Operations]

Parameter	Description	Min	Max	Units	
f_{SCLK}	SCLK frequency 100 ns delay inserted between address byte and data byte (single access), or between address and data, and between each data byte (burst access).	-	10	MHz	
	SCLK frequency, single access No delay between address and data byte		9	MHz	
	SCLK frequency, burst access No delay between address and data byte, or between data bytes		6.5	MHz	
$t_{sp,pd}$	CSn low to positive edge on SCLK, in power-down mode	150		μs	
t_{sp}	CSn low to positive edge on SCLK, in active mode	20	-	ns	
t_{ch}	Clock high	50	-	ns	
t_{cl}	Clock low	50	-	ns	
t_{rise}	Clock rise time	-	5	ns	
t_{fall}	Clock fall time	-	5	ns	
t_{sd}	Setup data (negative SCLK edge) to positive edge on SCLK (t_{sd} applies between address and data bytes, and between data bytes)	Single access	55	-	ns
		Burst access	76	-	ns
t_{nd}	Hold data after positive edge on SCLK	20	-	ns	
t_{ns}	Negative edge on SCLK to CSn high	20	-	ns	

[SPI Interface Timing Requirements]

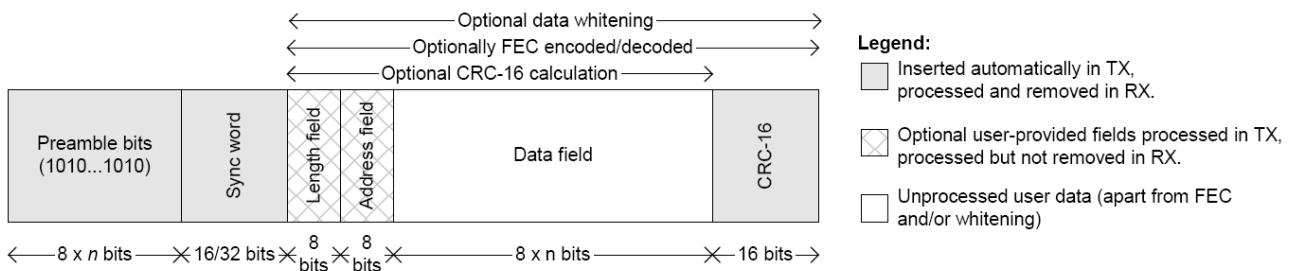

[Packet Format]

FCC Information to User

This equipment has been tested and found to comply with the limits for a Class B digital device, pursuant to Part 15 of the FCC Rules. These limits are designed to provide reasonable protection against harmful interference in a residential installation. This equipment generates, uses and can radiate radio frequency energy and, if not installed and used in accordance with the instructions, may cause harmful interference to radio communications. However, there is no guarantee that interference will not occur in a particular installation. If this equipment does cause harmful interference to radio or television reception, which can be determined by turning the equipment off and on, the user is encouraged to try to correct the interference by one of the following measures:

- Reorient or relocate the receiving antenna.
- Increase the separation between the equipment and receiver.
- Connect the equipment into an outlet on a circuit different from that to which the receiver is connected.
- Consult the dealer or an experienced radio/TV technician for help.

Caution

Modifications not expressly approved by the party responsible for compliance could void the user's authority to operate the equipment.

FCC Compliance Information : This device complies with Part 15 of the FCC Rules. Operation is subject to the following two conditions:

- (1) This device may not cause harmful interference, and
- (2) this device must accept any interference received, including interference that may cause undesired operation

IMPORTANT NOTE:

FCC RF Radiation Exposure Statement:

This equipment complies with FCC RF radiation exposure limits set forth for an uncontrolled environment. This equipment should be installed and operated with a minimum distance of 20 centimeters between the radiator and your body. This transmitter must not be co-located or operating in conjunction with any other antenna or transmitter.

This device is intended only for OEM integrators under the following conditions:

- 1) The antenna must be installed such that 20 cm is maintained between the antenna and users, and
- 2) The transmitter module may not be co-located with any other transmitter or antenna,
- 3) OEM shall not supply any tool or info to the end-user regarding to Regulatory Domain change.

As long as 3 conditions above are met, further transmitter test will not be required. However, the OEM integrator is still responsible for testing their end-product for any additional compliance requirements required with this module installed (for example, digital device emissions, PC peripheral requirements, etc.).

IMPORTANT NOTE: In the event that these conditions can not be met (for example certain laptop configurations or co-location with another transmitter), then the FCC authorization is no longer considered valid and the FCC ID can not be used on the final product. In these circumstances, the OEM integrator will be responsible for re-evaluating the end product (including the transmitter) and obtaining a separate FCC authorization.

Maximum antenna gain allowed for use with this device is 1.6dBi

End Product Labeling

This transmitter module is authorized only for use in device where the antenna may be installed such that 20 cm may be maintained between the antenna and users. The final end product must be labeled in a visible area with the following: "Contains FCC ID: **UP5H1 G1 GFE**"

Manual Information To the End User

The OEM integrator has to be aware not to provide information to the end user regarding how to install or remove this RF module in the user's manual of the end product which integrates this module. The end user manual shall include all required regulatory information/warning as show in this manual.

GUIDANCE REQUIREMENT / RESPONSIBILITY: Pursuant to the Transmitter Module Equipment Authorization Guide (KDB 996369 D01), the party responsible for the module grant shall provide guidance to the host manufacturer for compliance with the Part 15B requirements. Please acknowledge and document this responsibility.