

# X-4S MANUAL

## Contents

Before use-----	
• Support and Service-----	
- Customer Support-----	
- Internet sales site -----	
- A/S support & Warranty information -----	
- <b>OPENHOBBY A/S SUPPORT AND SERVICE CENTER</b> -----	
• Box Contents-----	
• Safety Warning Notes-----	
• System Features-----	
• Specification-----	
• Product Description-----	
• HoTT	
• <b>Operation</b>	
• Receiver installation	
• Steering & Trigger tension adjustment	
• Steering wheel position adjustment	
• Trigger Angle Adjustment	
• Installation for left-handed users	
• Binding and Range test	
• Control Switch Functions-----	P7
• Fail Safe mode Configuration -----	
• Trigger and Steering Calibration -----	
• LED and Buzzer Indication-----	
• Receiver port Description	
• Smart Box (Configuration by Telemetry)	
• Safety	

## BEFORE USE

Thank you for purchasing Graupner/SJ X-4S HoTT 2.4GHz Radio System. This system is extremely versatile and may be used by beginners and pros alike. In order for you to make the best use of your system, please read this manual carefully. If you have any difficulties while using your system, please consult the manual, our online Frequently Asked Questions (on the web pages referenced below), your hobby dealer, or the Graupner/SJ Service Center. Due to unforeseen changes in production procedures, the information contained in this manual is subject to change without notice.

## SUPPORT AND SERVICE

### • Customer support

We are happy to assist you with any question by e-mail or phone, Customer service hours are 9 AM to 5 PM (Pacific Standard Time) during the workweek, Monday through Friday. E-mailed questions will be answered as soon as possible.

### • Internet sales site

Please visit us at [www.openhobby.com](http://www.openhobby.com), for more information

### • A/S support

During the warranty period, we can repair this product at no cost for products that have become faulty under normal operating conditions. For non-functional products that are past the expiration date of the warranty or have been improperly used, we would be happy to repair this product for an appropriate amount of cost to the consumer

### • Warranty information

Refer the WARRANTY CARD in the Package

## **OPENHOBBY A/S SUPPORT AND SERVICE CENTER**

기존 사용내용 기재

### **BOX CONTENTS**

X-4S HoTT Transmitter  
Warranty Card  
GR-4 Receiver  
Temperature / Voltage Sensor (S8362)  
Battery Holder  
Alkaline 4 cells  
Manual

### **SAFETY WARNING NOTES**

- Never operate your car or truck in a crowded street with traffic. Especially, do not drive in a place near railway, chemical substance, gas to prevent any damage.
- This product is not intended for use by inexperienced or disabled person without direct supervision of a responsible, knowledgeable adult. This is not suitable for children under 18 years.
- This warranty does cover damaged products arising as a result of production process. It is not allowed to use to those who are the disabled or do not have enough knowledge.
- The radio system is affected by signal environment and the electronic jamming signals can cause disorientation and loss of control of your aircraft.
- Please read the manual to make the best use of the product
- Make sure to check all operations of channels before use.
- For the safe use, please operate the Range Check Mode before use.
- Be careful not to turn your transmitter off while in use.
- Do not touch or grab antenna during the use.
- Do not operate your model in the rain or run through standing water
- Fail Safe should be set before use to prevent uncontrollable situation occurred by any interruption. It is recommended to set throttle channel to Neutral condition or brake condition.
- Always operate your program setup mode after stopping motor's power or engine and disconnecting drive battery.
- Make sure whenever you start operating your transmitter, turn your transmitter before switching your receiver switch. Whenever you stop your transmitter, turn your receiver off before your transmitter is switched off.
- Always use new battery pack or charge your battery fully to avoid possible hazard causing by low battery capacity.
- Always be sure to check your battery capacity for your transmitter and receiver.
- As for boat model, we recommend installing your antenna vertically to the exterior boat and operating Range Check Mode for the best use of your model.

## System Features

### 1. HOPPING TELEMETRY TRANSMISSION (HoTT)

The use of up to 35 hopping channels provides advanced reliable operation while keeping from any external interference.

2. Designed for beginners, X-4S HoTT Transmitter is the best choice for those who enjoy car, boat, and tank models. When optional Graupner/SJ Telemetry sensor or temperature sensor is used, you may check the real-time information such as model voltage, user programmable warnings. It is easy to check from your transmitter.

3. Unlike other binding systems which are widely used, X-4S HoTT Transmitter supports the fast binding system which is operated by pressing a button.

## Specifications

### (1) X-4S Transmitter

Channel	<b>2CH</b>	
Operating Voltage	<b>4.8 ~ 6.0V</b>	
Battery Type	<b>Alkaline, Nixx 4 Cell</b>	
Operating Current	<b>app. 65mA</b>	
Operating Output Power	<b>App. 60 mW</b>	
Frequency	<b>2.4000 ~ 2.4835 GHz</b>	
Modulation	<b>FHSS</b>	
Operating Temperature	<b>app. -10 ~ +55° C</b>	<b>( app. -50 ~ +131°F )</b>
Antenna	<b>Dipole Antenna</b>	
Display	<b>LED Indicator</b>	
Low voltage warning alarm	<b>available (LED, Buzzer)</b>	
High temp warning alarm	<b>available (LED, Buzzer)</b>	
Battery Charging	<b>DC Jack</b>	
Extra Function	<b>available (Futaba 3p connector)</b>	
Size	<b>171.1 x 292.0 x 139.8 mm</b>	<b>( 6.74 x 11.49 x 5.50 in.)</b>
Weight	<b>365.7g</b>	<b>( 12.89 oz )</b>

## (2) GR-4 Receiver

Channel	2 CH
Frequency	2400~2483.5 MHz
Modulation	FHSS
Operating Voltage	3.6~8.4V
Operating Output Power	60mW
Operating Current	35.0mA
Display	One LED (red)
Extra Function	available (Port3)
Fail Safe	Free/Fail safe
Temperature Sensor Warning	(T/V Connector) Port4 (50~150°C)
Low voltage warning alarm	(T/V Connector) Port4 (1.0~25.5V)
Telemetry Sensor	(B/T Connector) Port3
Size	30x21x14.3 mm ( 1.18x0.82x0.56 in. )
Weight	app. 5.5 g (0.19 oz)

### Product description (Mechanical Parts)

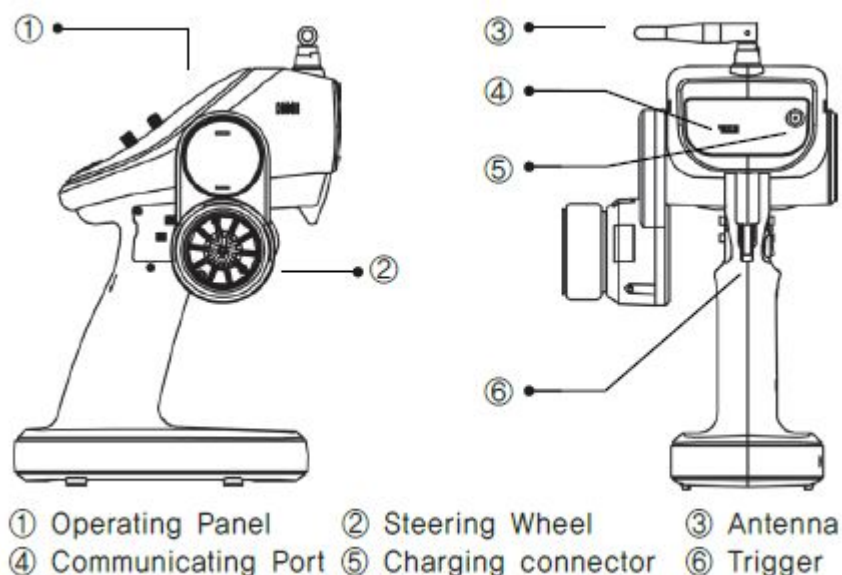

### HoTT (Hopping Telemetry Transmission)

The use of up to 35 hopping channels provides advanced reliable operation while keeping from any external interference. This HoTT radio system gives user real-time information on various useful data such as user model's RPM, voltage, temperature, user programmable warning, and so on. X-4S HoTT Transmitter comes with GR-4 2Ch receiver.

## Operation

### Battery Connection

- Only use optional manganese dry battery or NiCd /NiMH 1.2volt, individual AA size rechargeable battery. (LiPo battery must not be used.)
- Remove the cover and install your battery to battery socket. Then, replace the cover making sure it is closed securely.
- When low voltage warning alarm is activated, please use new battery or recharge the used battery. Please make sure the correct polarity when installing your battery.

### Low-voltage warning for transmitter battery

Please charge Alkaline 4 cell or Nixx 4 cell battery before use. When it will beep continuously due to low voltage warning, please stop an operation, then recharge your battery or replace it. (Do not use Lixx battery and please only use Alkaline or Nixx battery.)

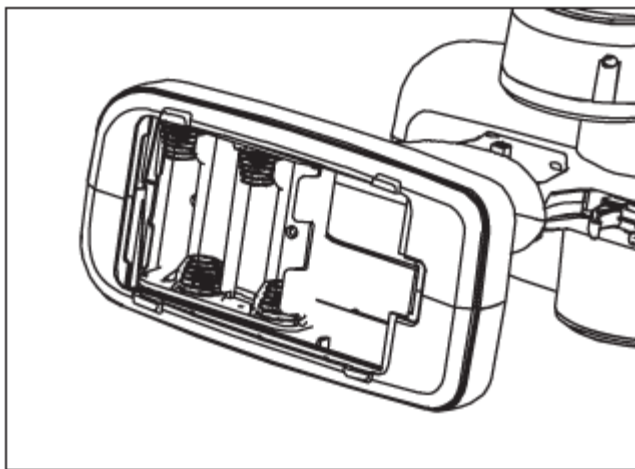

### Battery Charging

If rechargeable battery is in use, you can charge it up to 150mA with optional charging adapter. We may notice that little heating will be occurred during use, which means it is working properly. Now that this product features 4 cell battery packs, it is allowed to use within its specification. Otherwise, it may cause damage to your model.

### Cautions

The improper use will cause fire. So please keep the safety rules.

### Reference picture (Correct polarity)

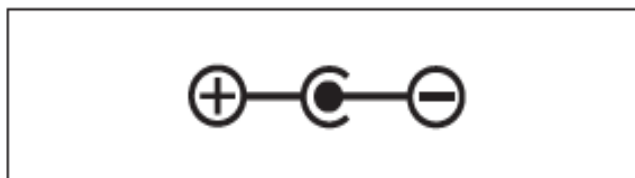

## Receiver installation

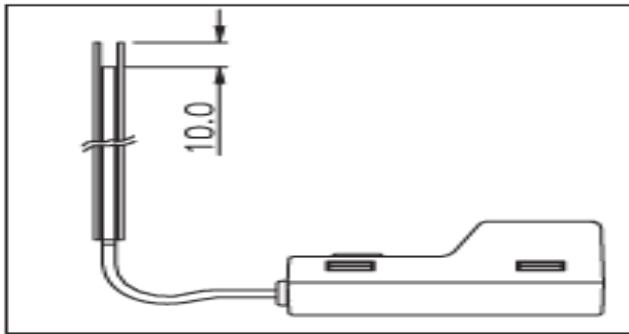

1. Install your receiver on the flat surface to avoid any oscillation.
2. Be aware you should keep your antenna at least 10mm away from any power wires to prevent interference.
3. Be sure not to cut off any antenna wire, as it will shorten your operating range.

## Steering and trigger tension adjustment

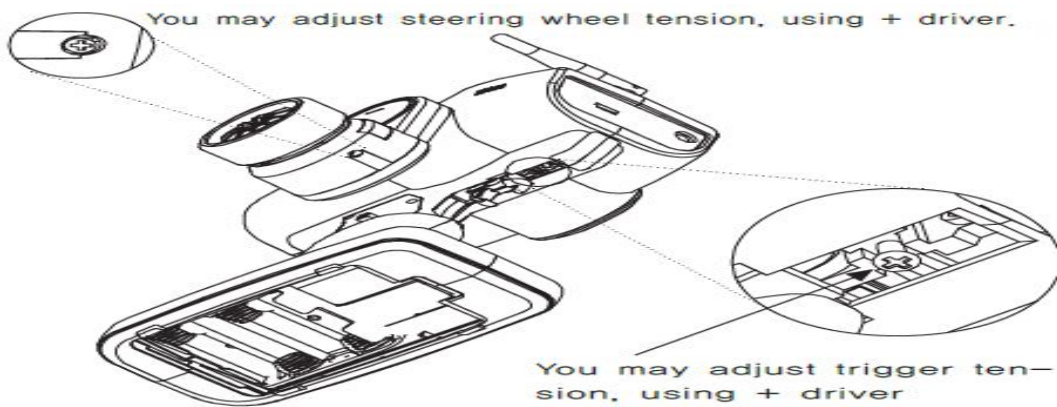

## Steering wheel position adjustment

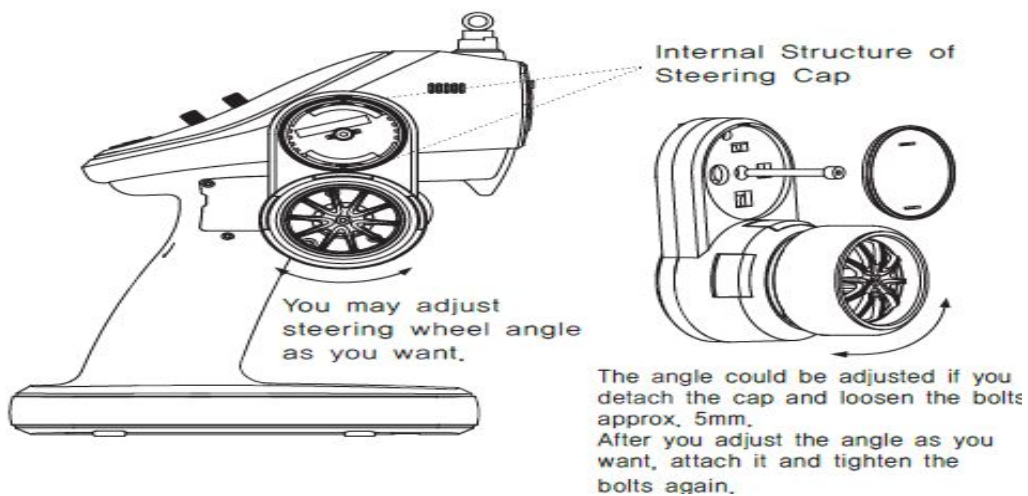

## Throttle Trigger Adjustment

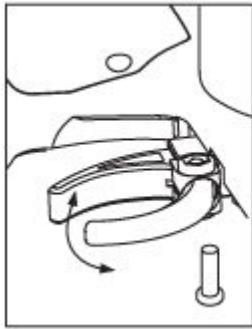

Loosen the bolts a little and adjust the throttle trigger as you want.

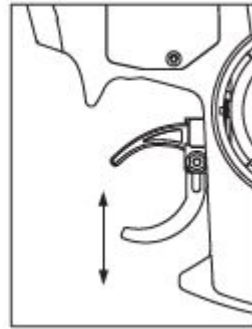

## Installation for Left-handed users

Disconnect your bolts and coverage.

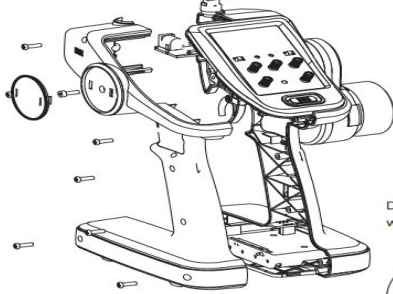

Disconnect steering wheel part.

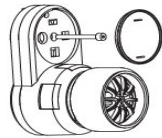

Disconnect transmitter connector.

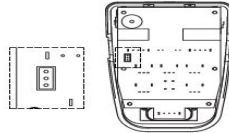

Install your steering wheel part on your left side. Then, install the connector again then, coverage and bolts. Now, your transmitter can be used for left-handed users.

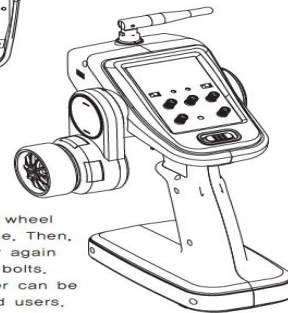

1. Disconnect your bolts and coverage.
2. Disconnect steering wheel part.
3. Disconnect transmitter connector.
4. Install your steering wheel part on your left side. Then, install the connector again then, coverage and bolts. Now, your transmitter can be used for left-handed users.

## Binding & RF Range Test

### BIND

Press and hold Bind button for 3 sec while your receiver is powered on and then LED indicator is off. Now press Bind button of your transmitter and then receiver's LED indicator is off.

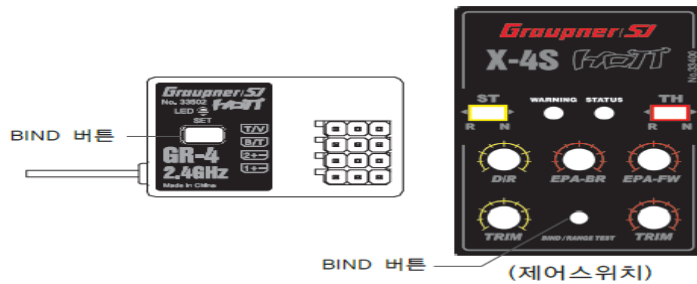

### RF RANGE TEST

When BIND button is touched after the connection between transmitter and receiver, RF RANGE TEST is now activated. RF RANGE TEST is continued during 90 seconds and it is automatically deactivated. RF RANGE TEST is deactivated by touching BIND button during RF RANGE TEST mode. Please note that your model is not controllable if your model is far away from you during Test mode due to the short transmit distance.

### Control Switch Functions

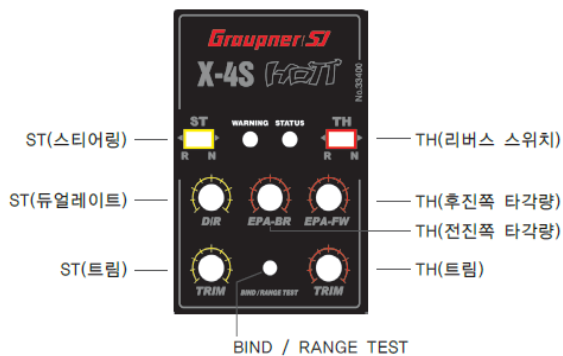

#### 1. REV (Reverse Switch)

This is used to change the direction of the servo travel for proper control when activated. If you steer right and the wheels go left, change the "ST" switch from "Nor" to "Rev" or "Rev" to "Nor" if needed. The same applies to the throttle.

#### 2. ST D/R (Steering Dual Rate)

It is used to adjust the overall travel of the steering servo. (Adjustable from 0 % to 150%)

#### 3. TH EPA-FW, EPA-BR (TH EPA-FW, EPA-BR)

This is used for throttle end point adjustment and for brake and reverse amount. (Adjustable from 0% to 150%)



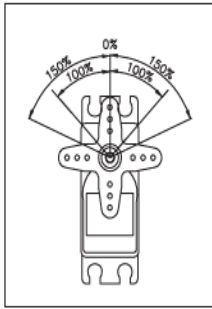

#### 4. TRIM

The trims are used to fine-tune the point where the servo returns to center.

(Adjustable from -37.5% to +37.5%)

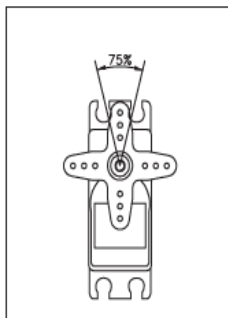

**ST:** Use the ST-TRIM so your vehicle will go perfectly straight when the steering wheel is centered.

(Adjustable from -37.5% to +37.5%)

**TH:** Use the THR-TRIM to adjust the amount of brake that occurs when your engine's idle is too low or high and your ESC is not perfectly at neutral.

(Adjustable from -37.5% to +37.5%)

#### Fail Safe Mode Configuration

It should be programmed after binding process. The default value is "Free" mode.

Fail Safe is set to throttle channel (CH2)

Move your throttle to the position on which you act fail safe mode. Now touch and hold BIND button for 3 sec until fail safe mode is set. (Buzzer beeps 3 times)

Press BIND button for 3 sec again and fail safe is deactivated. Now return to "Free" mode. (Buzzer beeps twice) After returning to Free mode, turn your transmitter off so that Fail safe mode is acting properly.



(Control Switch)

BIND Button

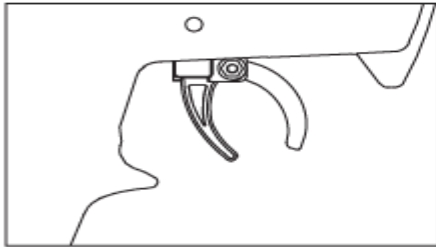

전동모델 페일세이프 위치 (중립)

Electric model's Fail safe position (Neutral)

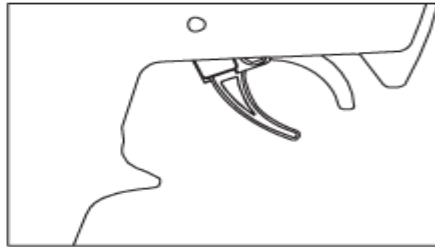

엔진모델 페일세이프 위치 (브레이크)

Engine model's Fail safe position (Brake):

### Trigger and Steering Calibration

While pressing BIND button, turn your transmitter on.

Press BIND button for 5 sec until your transmitter beeps twice and it is returned to Calibration Model.

Move steering and throttle to back and forward, left and right, then move to neutral position again.

Now your transmitter beeps twice, indicating Calibration Setup is now set.



(Control Switch)

BIND Button

<Steering wheel operation>

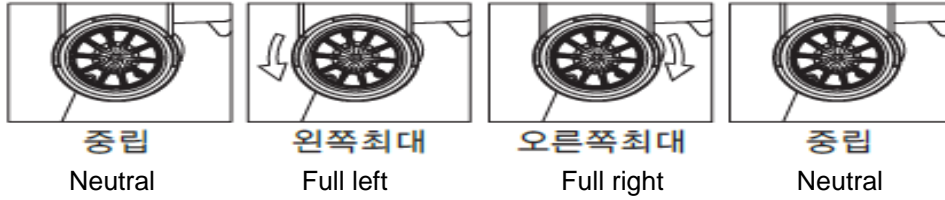

<Steering wheel operation>



**LED and Buzzer indication**

	Bind Switch	RED	GREEN	Buzzer
RX BIND ON	Push	-	ON	-
RX BIND OFF	-	-	Slow flash	-
Range TEST	Push (Bind on status)	-	Slow flash	Low 2Time(90sec)
Fail Safe Setup/Cancel	Push 3sec	-		Low 3Time
Free	(Bind on status)	-		Low 2Time
Warning Status				
Tx Receive Rate Low	-	1cycle	-	1cycle
Sensor Warning	-	2cycle	-	2cycle
Rx Ex Temp High	-	3cycle	-	3cycle
Rx Ex Volt Low	-	4cycle	-	4cycle
Rx Voltage Low	-	5cycle	-	5cycle
Tx Low Battery	-	6cycle	-	6cycle

**Receiver Port Description**

Descriptions

	Function	
Port1	Ch1 Signal output	
Port2	Ch2 Signal output	
Port3	Telemetry / Batt	(HoTT-v1 only)
Port4	Temp / Voltage	

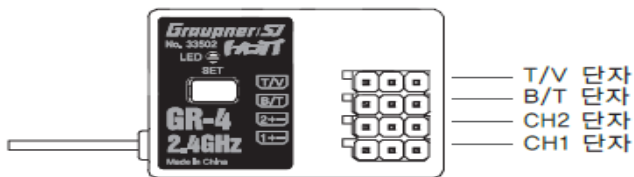

T/V CONNECTOR  
B/T CONNECTOR  
CH2 CONNECTOR

## CH1 CONNECTOR

- 1) Port 1, 2 should be connected with the servo or ESC.
- 2) Port 3 supports low voltage warning alarm with beep and LED indicator.  
In addition, it is available to use with telemetry sensor.

When using receiver battery (Nixx 4~5 cell, LiPo 2 cell), it needs to be connected to Port3.  
As for low voltage warning alarm, the default value is 3.7V.

**Caution:** When using LiPo 2 cell for receiver battery, you may protect your battery from any damage by using optional smart box, which ensures voltage adjustment and warning alarm function.

- 3) Port 4 (T/V connector) is designed that it will activate the beep and LED indicator when your engine gets hot.

Warning alarm would be activated if the batter is discharged down to 70% from fully charged within voltage range (1.0V~25.5V). If you connect the used battery which has already discharged capacity instead of fully charged battery, the warning alarm will be activated when the capacity of the used battery reaches down to 70% from its voltage capacity.

**Caution:** It is not allowed to connect your battery to T/V Connector directly. Please make sure to connect with Voltage/Temperature sensor cable (S8362). This port is only for measurement for the voltage of power battery. Please note that it is not for input power.

### <Voltage/Temperature Sensor Configuration> - Item/Order No. S8362

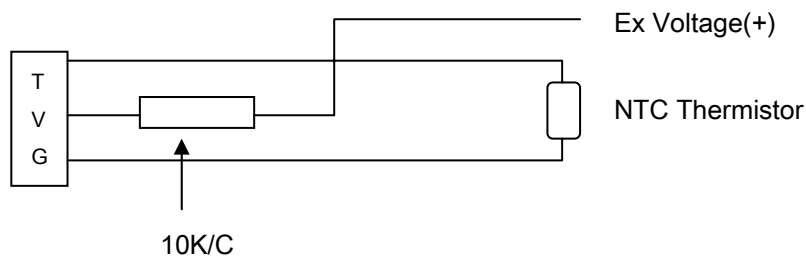

Ex Voltage (+): Connect ESC power connector (+)  
NTC Thermal: Connect Engine head

Connect sensor to Port 4(T/V Connector) as above. Temp sensor should be installed on engine head and Volt sensor should be installed on ESC power connector(+).

Caution: Warning alarm may not be activated, depending on weather condition or mounting location. If it is not activated, change mounting location or adjust temperature value with optional smart box (Telemetry box). (Default value: 100°C)

Caution: For your safe use, we recommend fully charging your battery before use. Warning alarm function is automatically activated when your battery capacity is lower than 70%, regardless of power battery's charging status.

#### 4) Receiver Indicator LED's

LED OFF: Very good signal condition  
LED blinks: Not good signal condition  
LED ON: No signal

## Electric & Engine model configuration

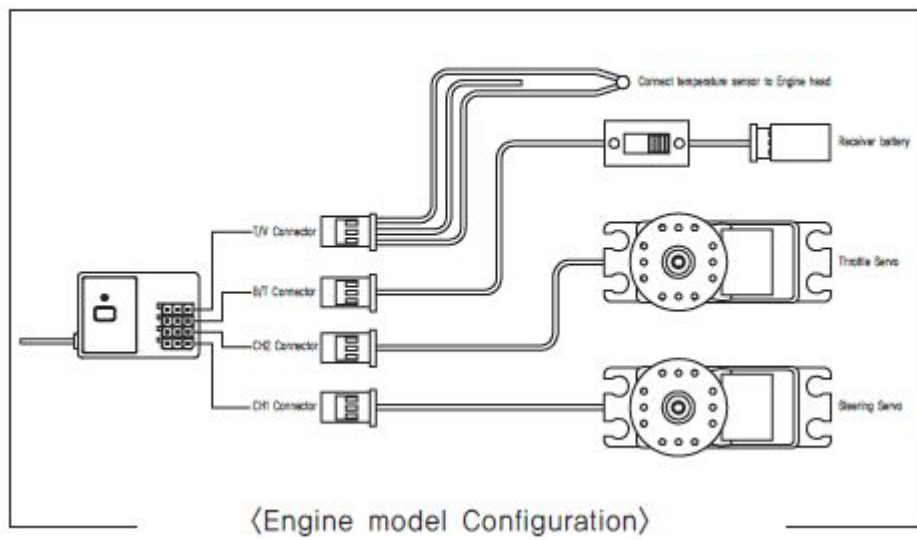
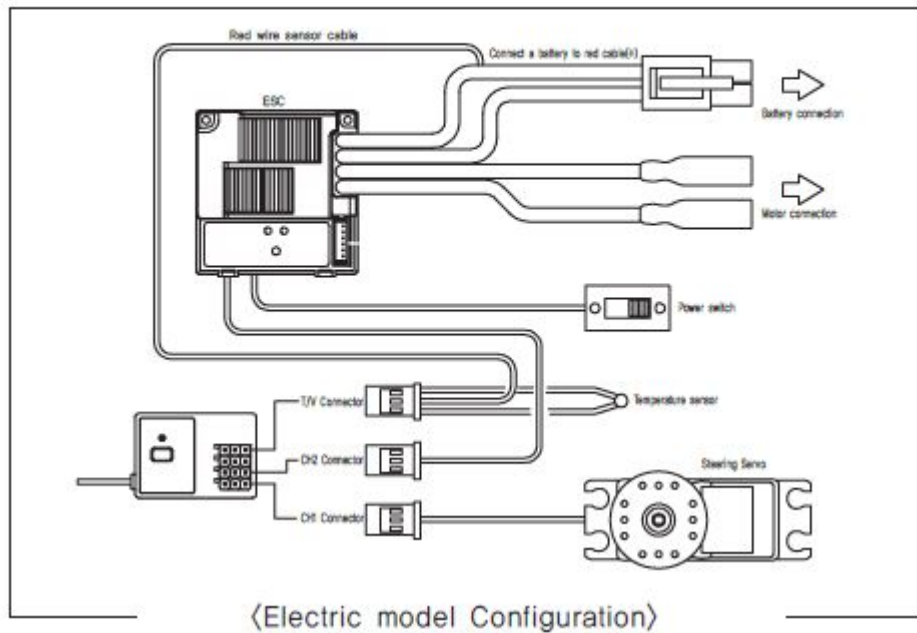

## Smart Box (Configuration by Telemetry)



The use of optional smart box supports easy configuration.  
When operating in SETTING & DATA VIEW mode in telemetry box, the screen appears as follows.

```
RECEIVER 0.01 >
>AL RX-V(5.1V) : 3.7V
AL RX-T(+33`C): 65`C
PERIOD       : 10ms
AL EX-V( 7.4V): AUTO
AL EX-T( 27`C): 100`C
```

### Smart Box (#33700)

#### 1. ALARM VOLT

It is used for low battery warning program. (Adjustable from 3.5V to 8.0V)  
The default value is 3.7V.

#### 2. ALARM TEMP

It is used for receiver's warning program (Adjustable from 30°C to 80°C)  
The default value is 65°C

#### 3. PERIOD

It is used to set the speed of receiver's output signal. (Selectable 10msec or 20msec)

#### 4. ALARM EX-VOLT

Selectable auto, 2.0V~24.0V (Default value: Auto)  
Detectable from 1.0V to 25.5V (LiPo 4 cell=max 25.2V)

In "Auto" selection, Low voltage warning alarm is activated at 70% of detected voltage when power is on.

#### 5. ALARM EX-TEMP

Connect Temperature Sensor to Port 4 (T/V Connector).  
Adjustable from 50°C to 150°C (Default value: 100°C)

※ If you have a transmitter that does not have the feature setup for temperature, the temperature is fixed at a specific value.

## © The Guide for the related Countries' Certifications

### (1) KC Information



- Graupner/SJ X-4S Transmitter  
KCC인증번호: MSIP-CRM-sjr-16005900
  - Graupner/SJ GR-4 Receiver  
KCC인증번호: MSIP-CRM-sjr-16005600
- 방송통신위원회고시 제2013-01호  
- 방송통신위원회고시 제2012-102호 "신고하지  
아니하고 개설했을 수 있는 무선기기"

### (2) Conformance Europeenne



- Product(s): Graupner/SJ X-4S Transmitter,  
Graupner/SJ GR-4 Receiver  
Item Number(s): No. 33400 , No 33502

**CE 0678**

- EN 62479:2010
- EN 60950-1:2006/A11:2009/A1:2010/A12:2011
- EN 301 489-1 V1.9.2
- EN 301-489-17 V2.2.1
- EN 300 328 V1.7.1

### (3) FCC Information

- Graupner/SJ X-4S Transmitter  
FCC ID: SNL-16005900
- Graupner/SJ GR-4 Receiver  
FCC ID: SNL-16005600

#### • FCC Statement

1. This device complies with Part 15 of the FCC Rules. Operation is subject to the following two conditions:

- (1) This device may not cause harmful interference.
- (2) This device must accept any interference received, including interference that may cause undesired operation.

2. Changes or modifications not expressly approved by the party responsible for compliance could void the user's authority to operate the equipment.



- NOTE

This equipment has been tested and found to comply with the limits for a Class B digital device, pursuant to Part 15 of the FCC Rules. These limits are designed to provide reasonable protection against harmful interference in a residential installation. This equipment generates uses and can radiate radio frequency energy and, if not installed and used in accordance with the instructions, may cause harmful interference to radio communications. However, there is no guarantee that interference will not occur in a particular installation. If this equipment does cause harmful interference to radio or television reception, which can be determined by turning the equipment off and on, the user is encouraged to try to correct the interference by one or more of the following measures:

- Reorient or relocate the receiving antenna.
- Increase the separation between the equipment and receiver.
- Connect the equipment into an outlet on a circuit different from that to which the receiver is connected.
- Consult the dealer or an experienced radio/TV technician for help.

- FCC radiation exposure statement

This equipment complies with FCC radiation exposure limits set forth for an uncontrolled environment. This equipment should be installed and operated with minimum distance of 20 cm between the radiator and your body.



## © ENVIRONMENTAL PROTECTION NOTES

This product must not be disposed of with other waste. Instead, it is the user's responsibility to their waste equipment by handing it over to a designated collection point for the recycling of waste electrical and electronic equipment. The separate collection and recycling of your waste equipment at the time of disposal will help to conserve natural resources and ensure that it is recycled in a manner that protects human health and the environment. For more information about where you can drop off your waste equipment for recycling, please contact your local city office, your household waste disposal service or where you purchased the produce

