

# Test Report of FCC CFR 47 Part 15 Subpart C

On Behalf of

**Graupner CO.,Ltd**

**FCC ID:** SNL-16005900  
**Product Description:** 2.4GHz Radio Control Computer System  
**Model No.:** X-4S  
**Supplementary Model:** N/A

**Prepared for:** **Graupner CO.,Ltd**  
202Dong 8<sup>th</sup> F,18, Bucheon-ro 198beon-gil, Wonmi-gu, Bucheon-si, Gyeonggi-do, Korea

**Prepared by:** **Bontek Compliance Testing Laboratory Co., Ltd**  
1/F, Block East H-3, OCT Eastern Ind. Zone, Qiaocheng East Road, Nanshan, Shenzhen, China  
Tel: 86-755-86337020  
Fax: 86-755-86337028

**Report No.:** BCT14CR052E  
**Issue Date:** April 1, 2014  
**Test Date:** March 12~ April 1, 2014

**Tested by:**

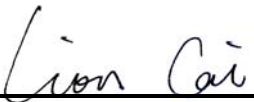
  
\_\_\_\_\_  
Lion Cai

**Reviewed by:**

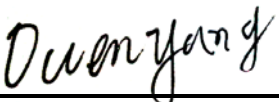
  
\_\_\_\_\_  
Owen Yang

**Approved by:**

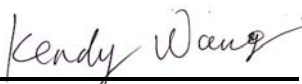
  
\_\_\_\_\_  
Kendy Wang

**TABLE OF CONTENTS**

**1. GENERAL INFORMATION .....4**  
1.1 PRODUCT DESCRIPTION FOR EQUIPMENT UNDER TEST (EUT) .....4  
1.2 RELATED SUBMITTAL(S) / GRANT (S) AND TEST METHODOLOGY .....5  
1.3 TEST FACILITY .....5

**2. SYSTEM TEST CONFIGURATION .....6**  
2.1 EUT CONFIGURATION .....6  
2.2 EUT EXERCISE .....6  
2.3 GENERAL TEST PROCEDURES .....6  
2.4 MEASUREMENT UNCERTAINTY .....6  
2.5 TEST EQUIPMENT LIST AND DETAILS .....7

**3. SUMMARY OF TEST RESULTS .....7**

**4. TEST OF AC POWER LINE CONDUCTED EMISSION.....8**  
4.1 APPLICABLE STANDARD .....8  
4.2 TEST SETUP DIAGRAM .....8  
4.3 TEST RESULT .....8

**5. TEST OF HOPPING CHANNEL BANDWIDTH .....9**  
5.1 APPLICABLE STANDARD .....9  
5.2 EUT SETUP .....9  
5.3 TEST EQUIPMENT LIST AND DETAILS .....9  
5.4 TEST PROCEDURE .....9  
5.5 TEST RESULT .....9

**6. TEST OF HOPPING CHANNEL SEPARATION.....12**  
6.1 APPLICABLE STANDARD .....12  
6.2 EUT SETUP .....12  
6.3 TEST EQUIPMENT LIST AND DETAILS .....12  
6.4 TEST PROCEDURE .....12  
6.5 TEST RESULT .....12

**7. TEST OF NUMBER OF HOPPING FREQUENCY .....15**  
7.1 APPLICABLE STANDARD .....15  
7.2 EUT SETUP .....15  
7.3 TEST EQUIPMENT LIST AND DETAILS .....15  
7.4 TEST PROCEDURE .....15  
7.5 TEST RESULT .....15

**8. TEST OF DWELL TIME OF EACH FREQUENCY .....17**  
8.1 APPLICABLE STANDARD .....17  
8.2 EUT SETUP .....17  
8.3 TEST EQUIPMENT LIST AND DETAILS .....17  
8.4 TEST PROCEDURE .....17  
8.5 TEST RESULT .....17

**9. TEST OF MAXIMUM PEAK OUTPUT POWER .....21**  
9.1 APPLICABLE STANDARD .....21  
9.2 EUT SETUP .....21  
9.3 TEST EQUIPMENT LIST AND DETAILS .....21  
9.4 TEST PROCEDURE .....21  
9.5 TEST RESULT .....21

**10. TEST OF BAND EDGES EMISSION .....24**  
10.1 APPLICABLE STANDARD .....24  
10.2 EUT SETUP .....24  
10.3 TEST EQUIPMENT LIST AND DETAILS .....24  
10.4 TEST PROCEDURE .....24  
10.5 TEST RESULT .....25

**11. TEST OF SPURIOUS RADIATED EMISSION .....27**

11.1 APPLICABLE STANDARD .....27  
11.2 EUT SETUP .....27  
11.3 TEST EQUIPMENT LIST AND DETAILS.....28  
11.4 TEST PROCEDURE .....28  
11.5 TEST RESULT .....29  
**12. ANTENNA REQUIREMENT .....42**  
12.1 STANDARD APPLICABLE .....42  
12.2 ANTENNA CONNECTED CONSTRUCTION .....42

# 1. GENERAL INFORMATION

## 1.1 Product Description for Equipment Under Test (EUT)

### Client Information

Applicant:	<b>Graupner CO.,Ltd</b>
Address of applicant:	202Dong 8 <sup>th</sup> F,18, Bucheon-ro 198beon-gil, Wonmi-gu, Bucheon-si, Gyeonggi-do, Korea
Manufacturer 1:	<b>SJ Technology(Shenzhen)Co.,Ltd</b>
Address of manufacturer:	F6, 1 Bldg, A Area, Yintianxifa Industrial Area, Xixiang Town, Baoan District Shenzhen, Guangdong Province, China
Manufacturer 2:	<b>Graupner CO.,Ltd</b>
Address of manufacturer:	202Dong 8 <sup>th</sup> F,18, Bucheon-ro 198beon-gil, Wonmi-gu, Bucheon-si, Gyeonggi-do, Korea

### General Description of E.U.T

Items	Description
EUT Description:	<b>2.4GHz Radio Control Computer System</b>
Model No.:	<b>X-4S</b>
Trade Name:	<b>HoTT</b>
Supplementary Model:	<b>N/A</b>
Frequency Band:	<b>2404.056~2474.025MHz</b>
Channel Spacing:	<b>1 MHz</b>
Number of Channels:	<b>70</b>
Type of Modulation:	<b>FHSS</b>
Antenna Gain	<b>1.2dBi</b>
Antenna Type:	<b>Integral Antenna</b>
Rated Voltage:	<b>Input: DC 3.4V~6V</b>

Remark: \* The test data gathered are from the production sample provided by the manufacturer.

## **1.2 Related Submittal(s) / Grant (s) and Test Methodology**

The tests were performed based on the Electromagnetic Interference (EMI) tests performed on the EUT. Both conducted and radiated testing were performed according to the procedures in ANSI C63.4 - 2003 Radiated testing was performed at an antenna to EUT distance 3 meters.

The tests were performed in order to determine compliance with FCC Part 15, Subpart C, and section 15.203, 15.207, 15.209 and 15.247 rules. Test was carried out according to the above mentioned FCC rules and the FCC publication notice DA 00-705: Filing and Measurement Guidelines for Frequency Hopping Spread Spectrum Systems

### **1.3 Test Facility**

All measurement required was performed at laboratory of Shenzhen CTL Testing Technology Co., Ltd. at Floor 1-A, Baisha Technology Park, No.3011, Shaheji Road, Nanshan District, Shenzhen, China 518055.

The test facility is recognized, certified, or accredited by the following organizations:

#### **FCC – Registration No.: 970318**

Shenzhen CTL Testing Technology Co., Ltd. EMC Laboratory has been registered and fully described in a report filed with the (FCC) Federal Communications Commission. The acceptance letter from the FCC is maintained in our files. Registration 970318, December, 2013.

## 2. SYSTEM TEST CONFIGURATION

### 2.1 EUT Configuration

The EUT configuration for testing is installed on RF field strength measurement to meet the Commissions requirement and operating in a manner that intends to maximize its emission characteristics in a continuous normal application.

### 2.2 EUT Exercise

The calibrated antennas used to sample the radiated field strength are mounted on a non-conductive, motorized antenna mast 3 or 10 meters from the leading edge of the turntable.

### 2.3 General Test Procedures

**Conducted Emissions:** The EUT is placed on the turntable, which is 0.8 m above ground plane. According to the requirements in Section 7.1 of ANSI C63.4-2003 Conducted emissions from the EUT measured in the frequency range between 0.15 MHz and 30MHz using CISPR Quasi-Peak detector mode.

**Radiated Emissions:** The EUT is a placed on as turntable, which is 0.8 m above ground plane. The turntable shall rotate 360 degrees to determine the position of maximum emission level. EUT is set 3m away from the receiving antenna, which varied from 1m to 4m to find out the highest emission. And also, each emission was to be maximized by changing the polarization of receiving antenna both horizontal and vertical. In order to find out the maximum emissions, exploratory radiated emission measurements were made according to the requirements in Section 13.1.4.1 of ANSI C63.4-2003.

### 2.4 Measurement Uncertainty

Where relevant, the following measurement uncertainty levels have been estimated for tests performed on the apparatus:

Parameter	Uncertainty
Power Line Conducted Emission	+/- 2.3 dB
Radiated Emission	+/- 3.4 dB

Uncertainty figures are valid to a confidence level of 95%.

## 2.5 Test Equipment List and Details

Test equipments list of Shenzhen CTL Testing Technology Co., Ltd.

Test Equipment	Manufacturer	Model No.	Serial No.	Calibration Date	Calibration Due Date
Bilog Antenna	Sunol Sciences Corp.	JB1	A061713	2013/07/12	2014/07/11
EMI Test Receiver	R&S	ESCI3	103710	2013/07/10	2014/07/09
EMI Test Receiver	R&S	ESPI	1164.6407.07	2013/07/10	2014/07/09
Spectrum Analyzer	Agilent	E4407B	MY45108355	2013/07/06	2014/07/05
Controller	EM Electronics	Controller EM 1000	N/A	2013/07/06	2014/07/05
Horn Antenna	Sunol Sciences Corp.	DRH-118	A062013	2013/07/12	2014/07/11
Horn Antenna	SCHWARZBECK	BBHA9170	1562	2013/07/12	2014/07/11
Active Loop Antenna	SCHWARZBECK	FMZB1519	1519-037	2013/07/12	2014/07/11
LISN	R&S	ENV216	101316	2013/07/10	2014/07/09
LISN	SCHWARZBECK	NSLK8127	8127687	2013/07/10	2014/07/09
Microwave Preamplifier	HP	8349B	3155A00882	2013/07/10	2014/07/09
Amplifier	HP	8447D	3113A07663	2013/07/10	2014/07/09
Transient Limiter	Com-Power	LIT-153	532226	2013/07/10	2014/07/09

## 3. SUMMARY OF TEST RESULTS

FCC Rules	Description of Test	Result
FCC §15.207	AC Power Line Conducted Emission	Pass
FCC §15.247(a)(1)	Hopping Channel Bandwidth	Pass
FCC §15.247(a)(1)	Hopping Channel Separation	Pass
FCC §15.247(a)(1)	Number of Hopping Frequency Used	Pass
FCC §15.247(a)(1)(iii)	Dwell Time of Each Frequency	Pass
FCC §15.247(b)(1)	Maximum Peak Output Power	Pass
FCC §15.247(d)	Band Edges Emission	Pass
FCC §15.247(d)	Spurious Radiated Emission	Pass
FCC §15.203/15.247(b)/(c)	Antenna Requirement	Pass

## 4. TEST OF AC POWER LINE CONDUCTED EMISSION

### 4.1 Applicable Standard

Refer to FCC §15.207.

For a Low-power Radio-frequency Device is designed to be connected to the AC power line, the radio frequency voltage that is conducted back onto the AC power line on any frequency or frequencies within the band 150 kHz to 30 MHz shall not exceed below limits table.

Frequency Range (MHz)	Limits ( dBuV)	
	Quasi-Peak	Average
0.150~0.500	66~56	56~46
0.500~5.000	56	46
5.000~30.00	60	50

### 4.2 Test Setup Diagram

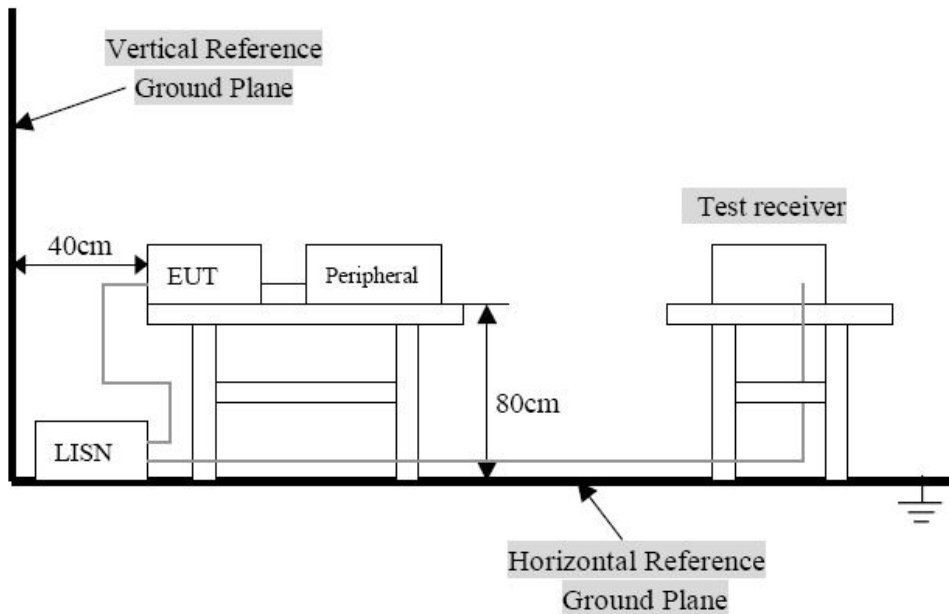

Remark: The EUT was connected to a 120VAC/ 60Hz power source.

### 4.3 Test Result

Notes: The EUT is powered by battery without AC mains(with battery),this test is not applicable.



## 5. Test of Hopping Channel Bandwidth

### 5.1 Applicable Standard

Section 15.247(a)(1): Frequency hopping systems shall have hopping channel carrier frequencies separated by a minimum of 25 kHz or the 20 dB bandwidth of the hopping channel, whichever is greater.

### 5.2 EUT Setup

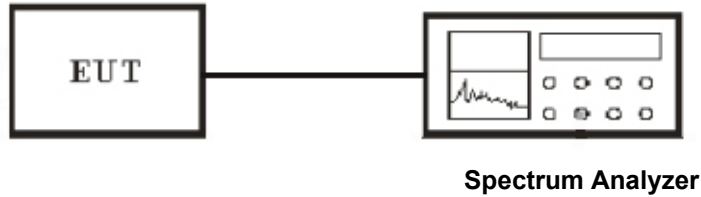

### 5.3 Test Equipment List and Details

See section 2.5.

### 5.4 Test Procedure

1. The transmitter output was connected to the spectrum analyzer through an attenuator.
2. Use the following spectrum analyzer settings:  
 Span = approximately 2 to 3 times the 20 dB bandwidth, centered on a hopping channel  
 RBW  $\geq$  1% of the 20 dB bandwidth, VBW  $\geq$  RBW  
 Sweep = auto  
 Detector function = peak  
 Trace = max hold
3. The spectrum width with level higher than 20dB below the peak level.
4. Repeat above 1~3 points for the middle and highest channel of the EUT.

### 5.5 Test Result

Temperature ( °C ) : 22~23	EUT: 2.4GHz Radio Control Computer System
Humidity (%RH) : 50~54	M/N: X-4S
Barometric Pressure ( mbar ) : 950~1000	Operation Condition: Tx Mode

Modulation Type	Channel No.	Frequency (MHz)	20dB Bandwidth (kHz)	Min. Limit (kHz)
FHSS	Low	2404.056	776	>25
FHSS	Middle	2438.553	792	>25
FHSS	High	2474.025	794	>25

Channel Low:



Channel Middle:

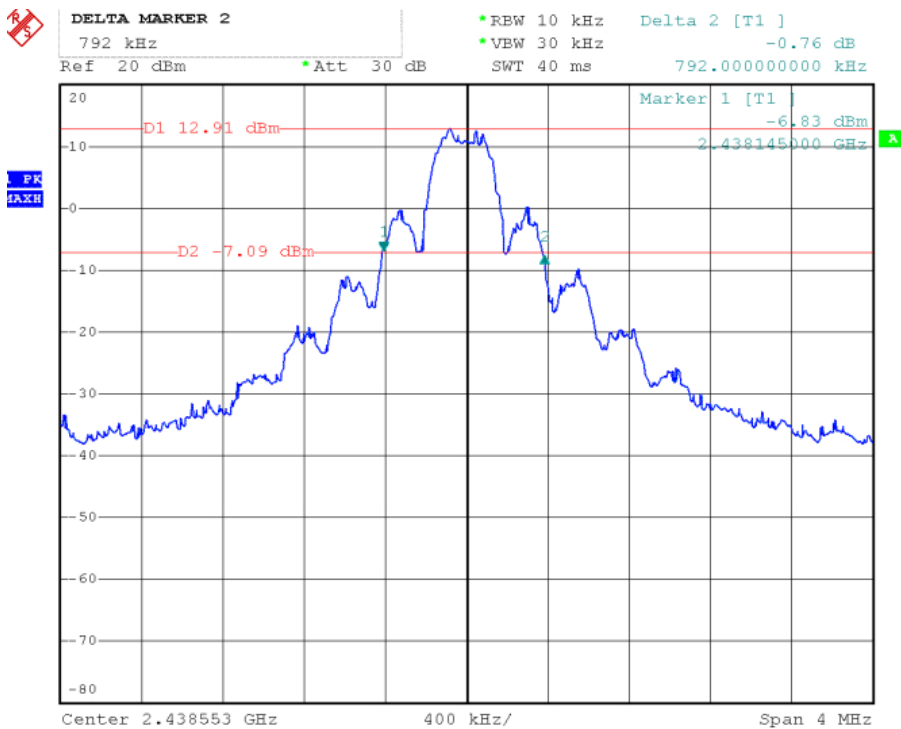

Channel High:

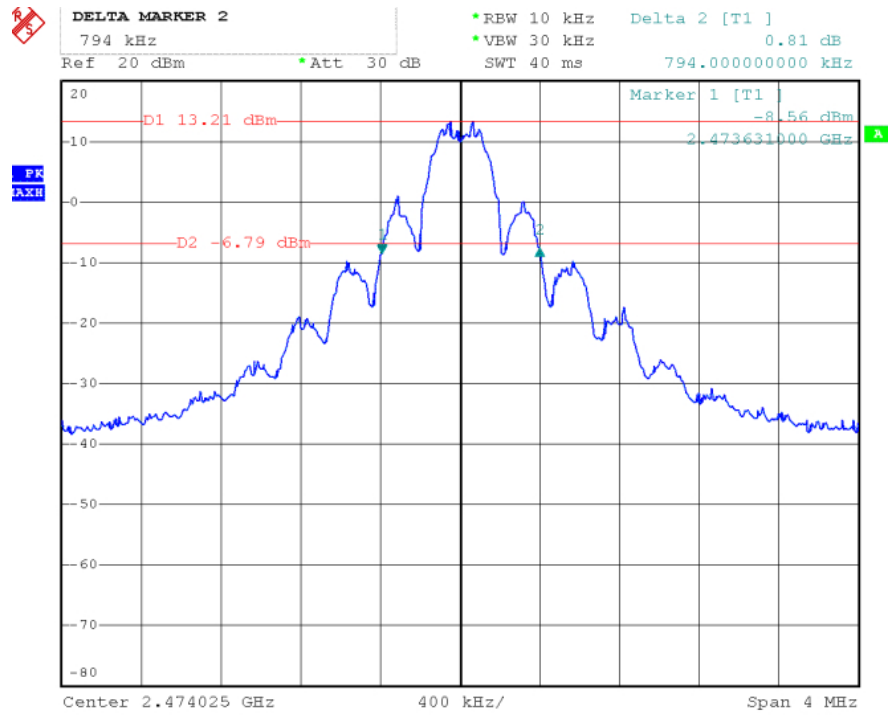

## 6. Test of Hopping Channel Separation

### 6.1 Applicable Standard

Section 15.247(a)(1): Frequency hopping systems shall have hopping channel carrier frequencies separated by a minimum of 25 kHz or the 20 dB bandwidth of the hopping channel, whichever is greater.

### 6.2 EUT Setup

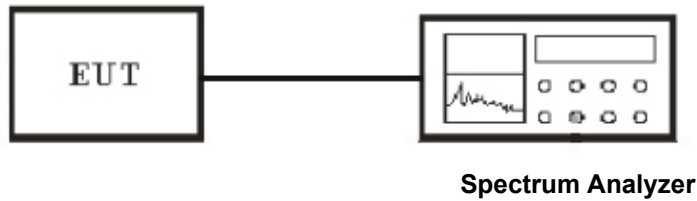

### 6.3 Test Equipment List and Details

See section 2.5.

### 6.4 Test Procedure

1. The transmitter output was connected to the spectrum analyzer through an attenuator.
2. Set RBW of spectrum analyzer to 100KHz and VBW to 100KHz.
3. Set Detector to Peak, Trace to Max Hold and Sweep Time is Auto.
4. The Hopping Channel Separation is defined as the separation between 2 neighboring hopping frequencies.
5. Repeat above 1~3 points for the middle and highest channel of the EUT.

### 6.5 Test Result

Temperature ( °C ) : 22~23	EUT: 2.4GHz Radio Control Computer System
Humidity (%RH) : 50~54	M/N: X-4S
Barometric Pressure ( mbar ) : 950~1000	Operation Condition: Tx Mode

Modulation Type	Frequency (MHz)	Channel Separation (MHz)	Min. Limit (kHz)
FHSS	2404.056~2405.056	1.040	>25
FHSS	2438.553~2439.553	1.028	>25
FHSS	2473.025~2474.025	1.012	>25

Channel Low:

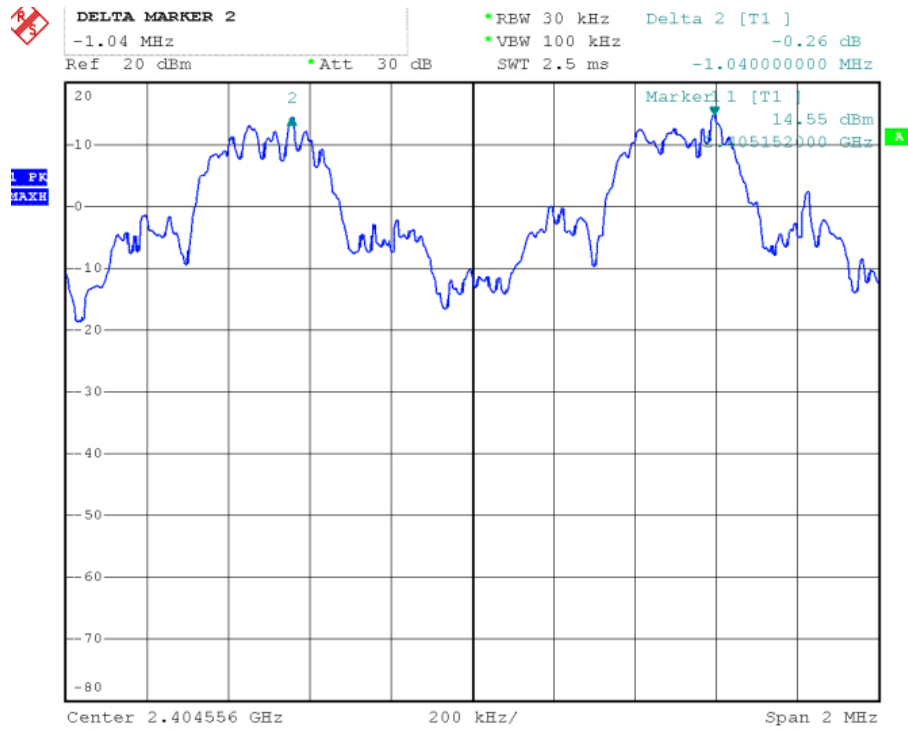

Channel Middle:

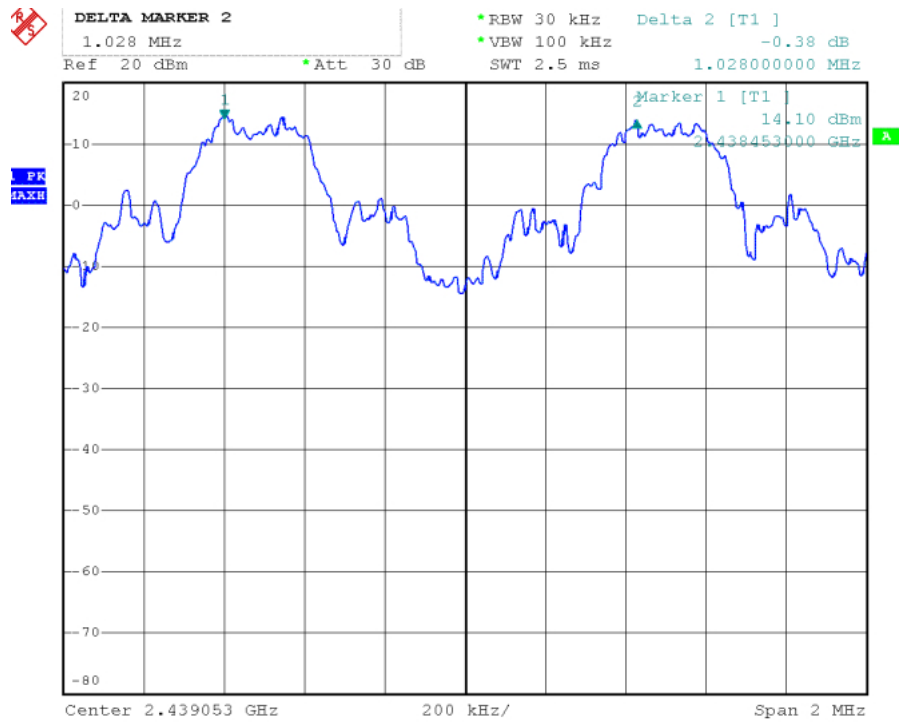

Channel High:

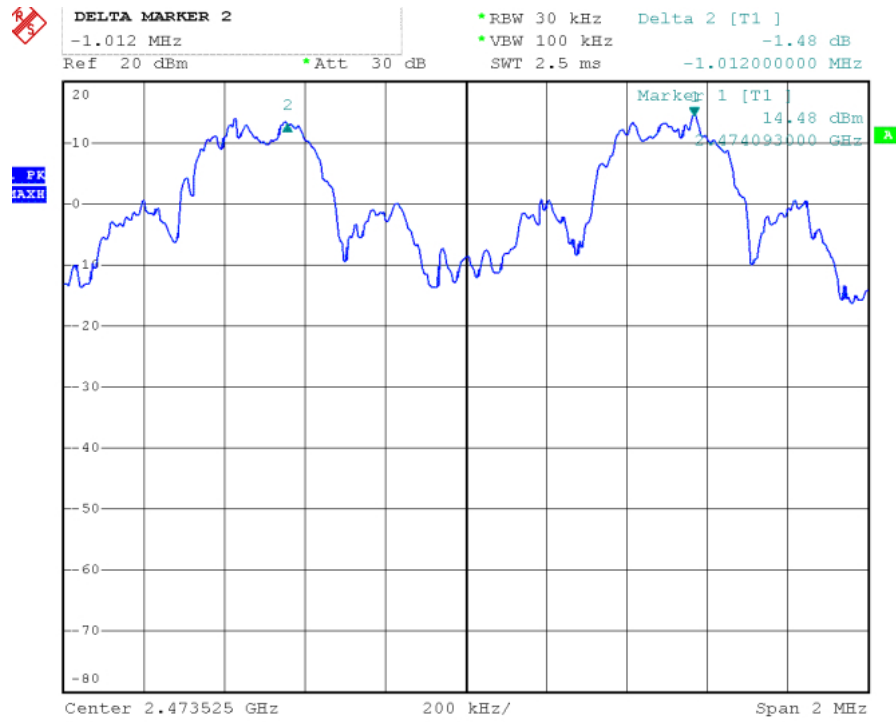

## 7. Test of Number of Hopping Frequency

### 7.1 Applicable Standard

Section 15.247(a)(1)(iii): For frequency hopping systems operating in the 2400-2483.5 MHz band employing at least 15 non-overlapping hopping channels. Frequency hopping system which use fewer than 75 hopping frequencies may employ intelligent hopping techniques to avoid interference to other transmissions. Frequency hopping system may avoid or suppress transmissions on a particular hopping frequency provided that a minimum of 15 non-overlapping channels are used.

### 7.2 EUT Setup

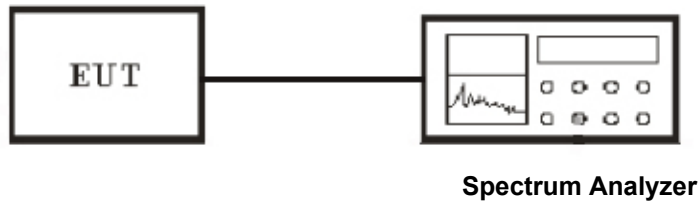

### 7.3 Test Equipment List and Details

See section 2.5.

### 7.4 Test Procedure

1. The transmitter output was connected to the spectrum analyzer through an attenuator.
2. Set RBW of spectrum analyzer to 100KHz and VBW to 100KHz.
3. Set Detector to Peak, Trace to Max Hold and Sweep Time is Auto.
4. Observe frequency hopping in 2400MHz~2483.5MHz, there are at least 32 non-overlapping channels.
5. Repeat above 1~3 points for the middle and highest channel of the EUT.

### 7.5 Test Result

Temperature ( °C ) : 22~23	EUT: 2.4GHz Radio Control Computer System
Humidity (%RH) : 50~54	M/N: X-4S
Barometric Pressure ( mbar ) : 950~1000	Operation Condition: Tx Mode

Modulation Type	Frequency (MHz)	Number of Hopping Channels	Min. Limit
FHSS	2404.056~2474.025	70	≥ 15

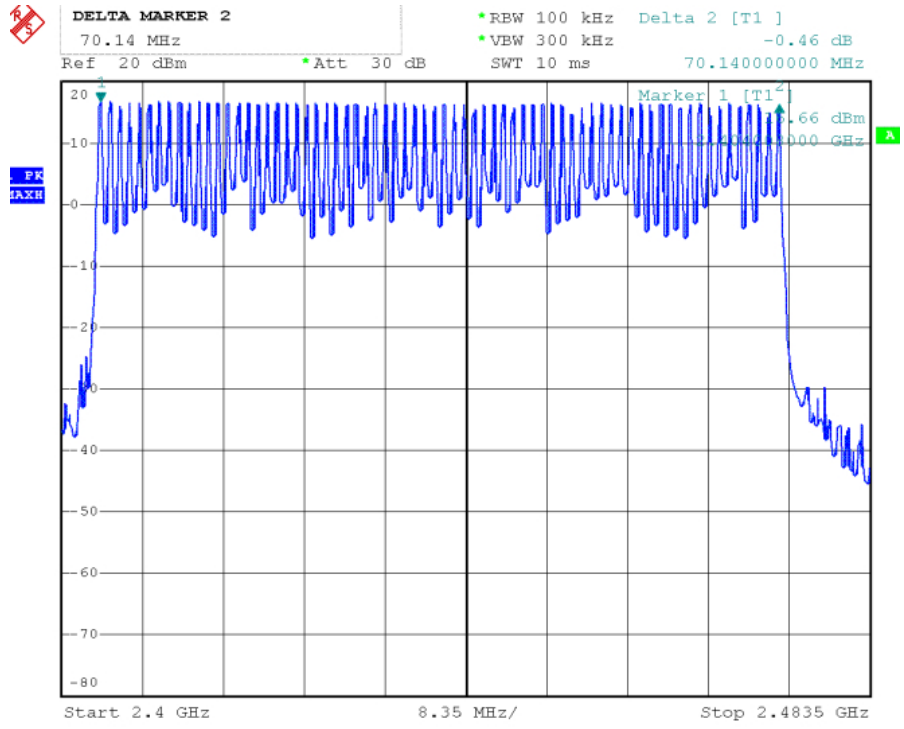



## 8. Test of Dwell Time of Each Frequency

### 8.1 Applicable Standard

Section 15.247(a)(1)(iii): For frequency hopping systems operating in the 2400-2483.5 MHz band The average time of occupancy on any channel shall not be greater than 0.4 seconds within a period of 0.4seconds multiplied by the number of hopping channels employed.

### 8.2 EUT Setup

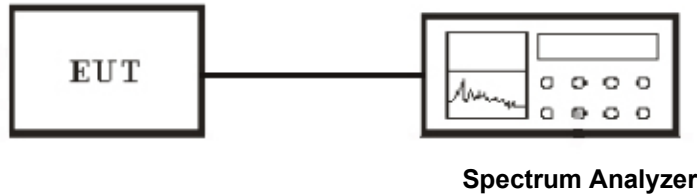

### 8.3 Test Equipment List and Details

See section 2.5.

### 8.4 Test Procedure

1. The transmitter output was connected to the spectrum analyzer through an attenuator.
2. Set RBW of spectrum analyzer to 1000kHz and VBW to 1000kHz.
3. Set Detector to Peak, Trace to Max Hold and Sweep Time is more than once pulse time.
4. Set the center frequency on any frequency would be measure and set the frequency span to zero span.
5. Measure the maximum time duration of one single pulse.

### 8.5 Test Result

Temperature ( °C ) : 22~23	EUT: 2.4GHz Radio Control Computer System
Humidity (%RH) : 50~54	M/N: X-4S
Barometric Pressure ( mbar ) : 950~1000	Operation Condition: Tx Mode

Modulation Type	Channel No.	Frequency (MHz)	Dwell Time (ms)	Limit (ms)
FHSS	Low	2404.056	141.512	400
FHSS	Middle	2438.553	141.512	400
FHSS	High	2474.025	141.512	400

A period time = 0.4 (ms) \* 70 = 28 (s)  
N=38  
CH Low:  
Time slot = 3.724(ms)  
Dwell time=N\*T= 38\*3.724=141.512(ms)

CH Mid:  
Time slot = 3.724(ms)  
Dwell time=N\*T= 38\*3.724=141.512(ms)

CH High:  
Time slot = 3.724(ms)  
Dwell time=N\*T= 38\*3.724=141.512(ms)

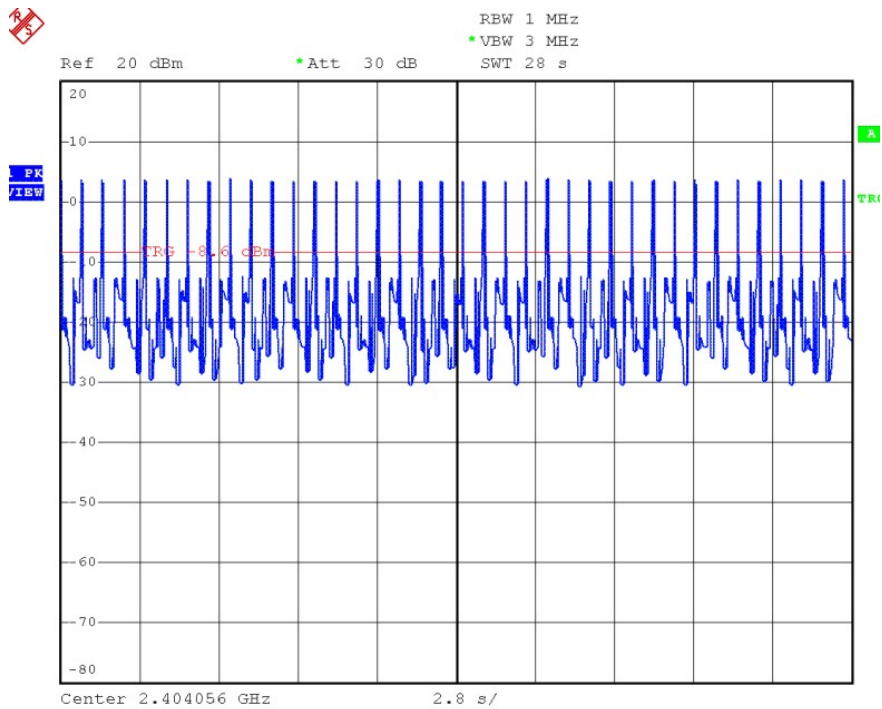

Channel Low:

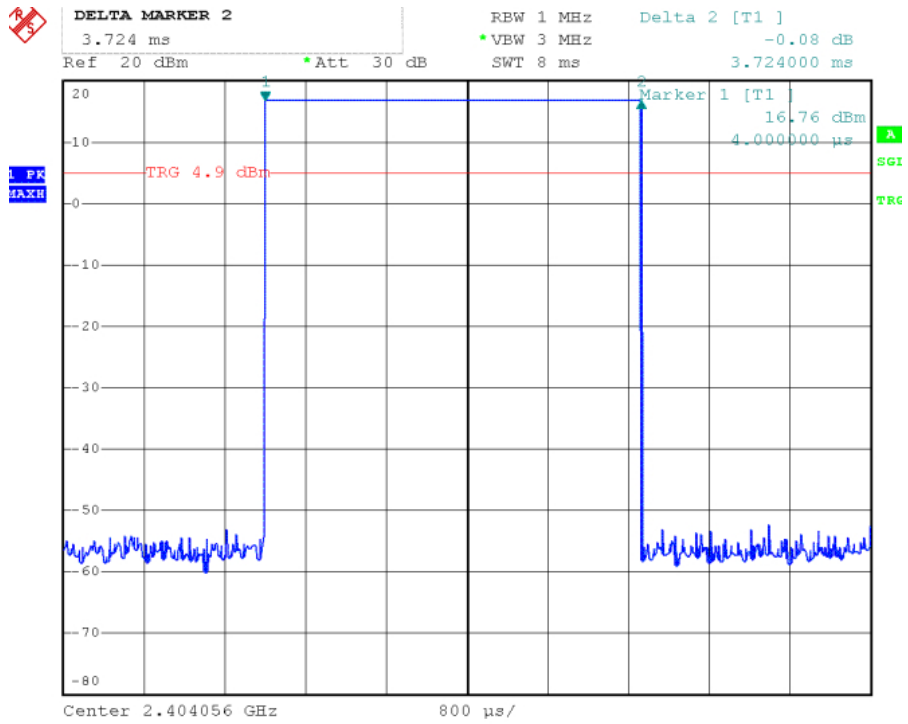

Channel Middle:

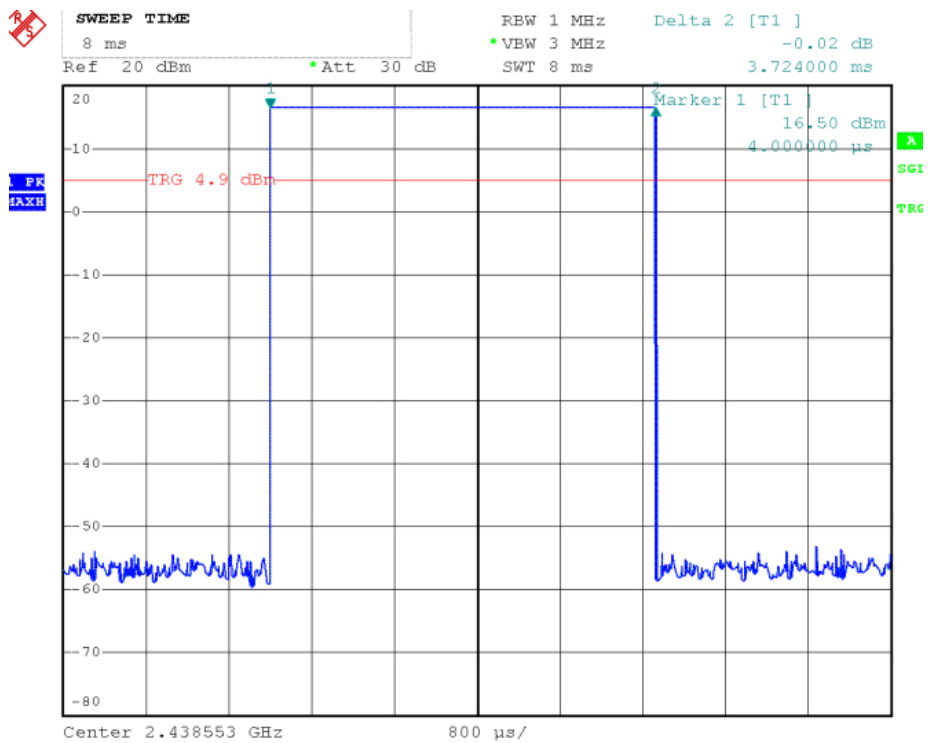

Channel High:

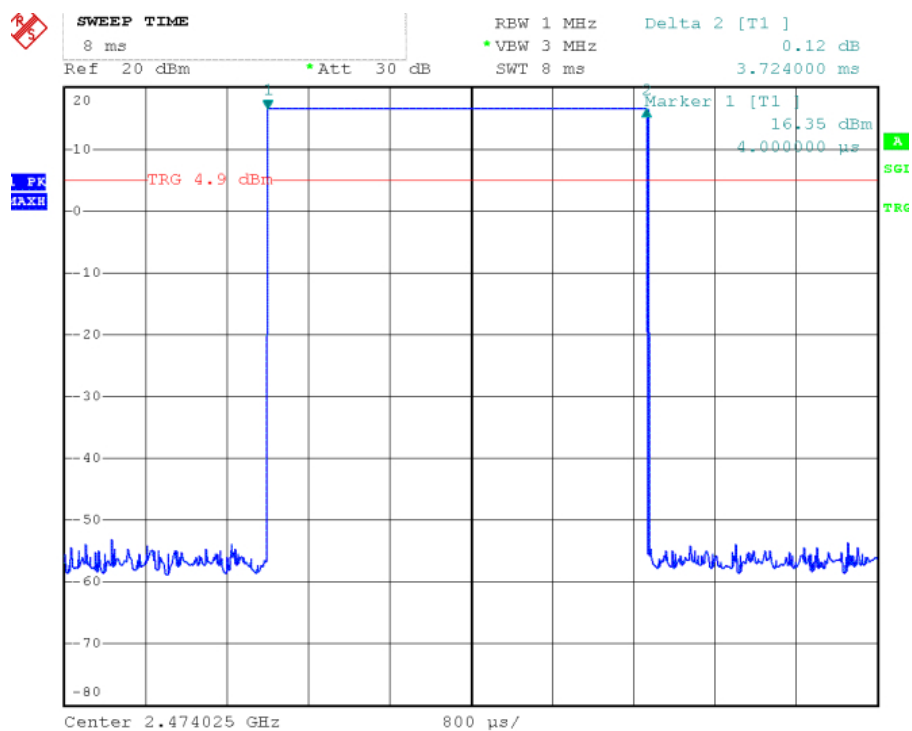

## 9. Test of Maximum Peak Output Power

### 9.1 Applicable Standard

Section 15.247(b)(1): For frequency hopping systems operating in the 2400-2483.5 MHz band employing at least 75 non-overlapping hopping channels and The maximum peak output power shall not exceed 1 watt. For all other frequency hopping systems in this frequency band, The maximum peak output power shall not exceed 0.125 watt.

### 9.2 EUT Setup

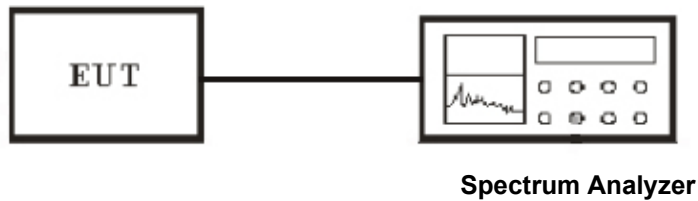

### 9.3 Test Equipment List and Details

See section 2.5.

### 9.4 Test Procedure

1. The transmitter output was connected to the peak power meter and recorded the peak value.
2. Peak power meter parameter set to auto attenuator and filter is the same as.
3. Repeated the 1 for the middle and highest channel of the EUT.

### 9.5 Test Result

Temperature ( °C ) : 22~23	EUT: 2.4GHz Radio Control Computer System
Humidity (%RH) : 50~54	M/N: X-4S
Barometric Pressure ( mbar ) : 950~1000	Operation Condition: Tx Mode

Modulation Type	Channel No.	Frequency (MHz)	Output Power (dBm)
FHSS	Low	2404.056	16.88
FHSS	Middle	2438.553	16.45
FHSS	High	2474.025	16.51

Channel Low:

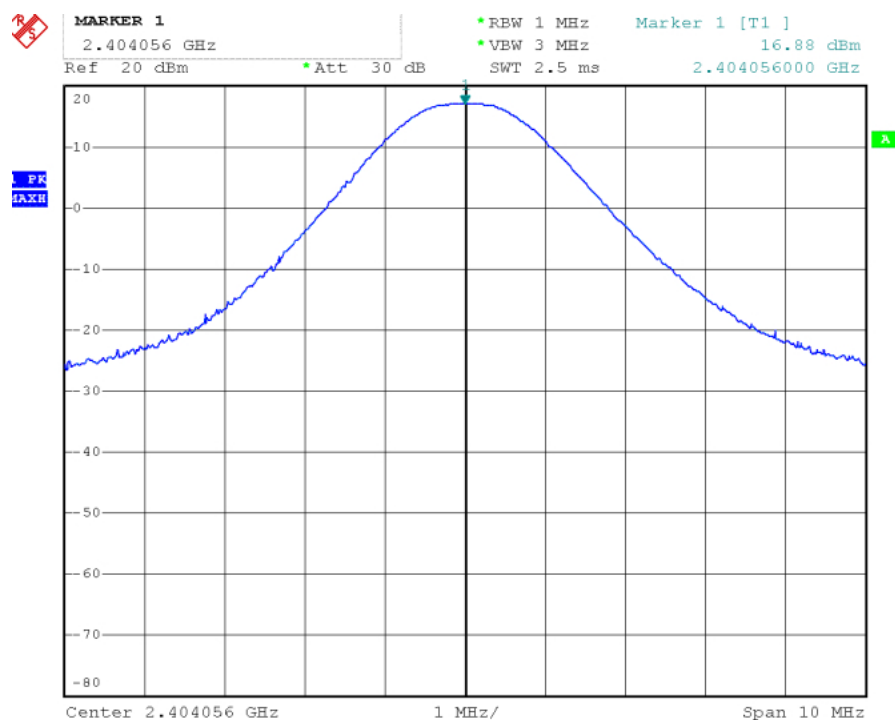

Channel Middle:

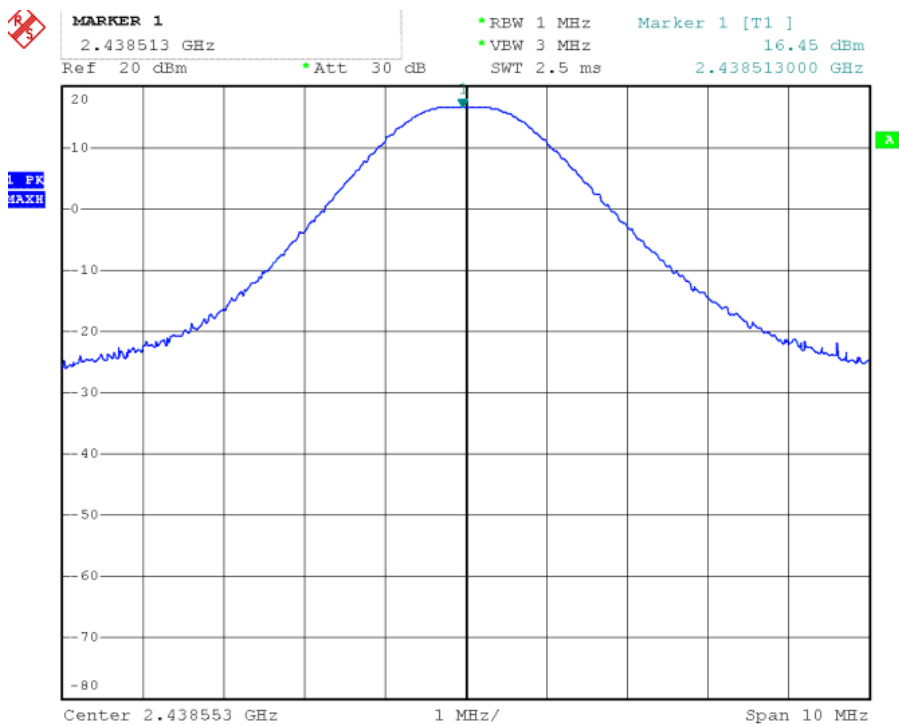

Channel High:

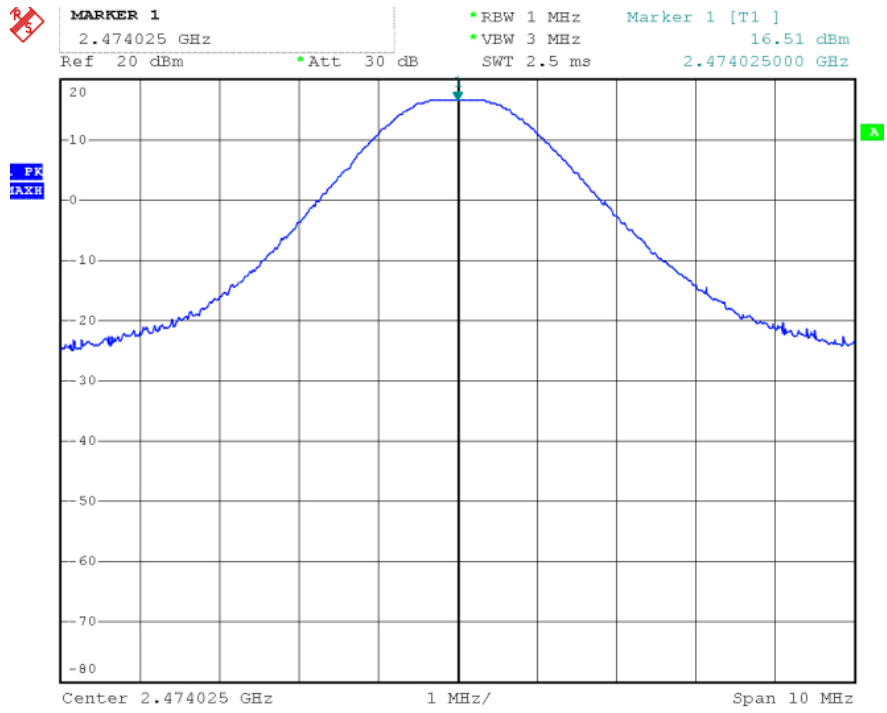

## 10. Test of Band Edges Emission

### 10.1 Applicable Standard

Section 15.247(d): In any 100 kHz bandwidth outside the frequency band in which the spread spectrum or digitally modulated intentional radiator is operating, the radio frequency power that is produced by the intentional radiator shall be at least 20 dB below that in the 100 kHz bandwidth within the band that contains the highest level of the desired power, based on either an RF conducted or a radiated measurement. In addition, radiated emissions that fall in the restricted bands, as defined in Section 15.205, must also comply with the radiated emission limits specified in Section 15.209.

### 10.2 EUT Setup

Radiated Measurement Setup

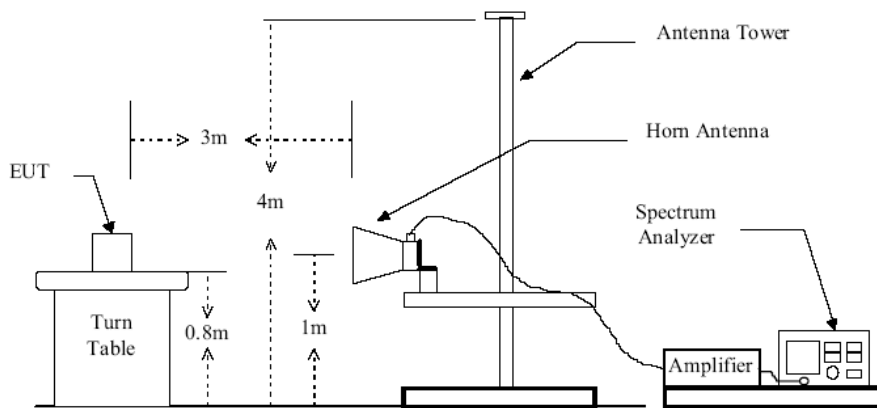
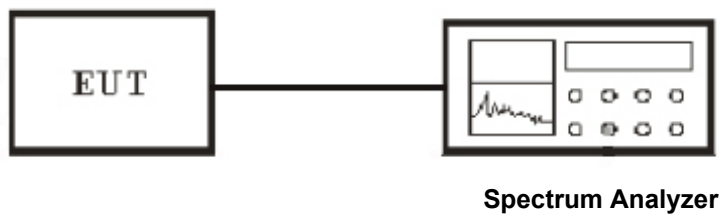

Figure 2 : Frequencies measured above 1 GHz configuration

Conducted Measurement Setup



### 10.3 Test Equipment List and Details

See section 2.5.

### 10.4 Test Procedure

Conducted Measurement

1. The transmitter is set to the lowest channel.
2. The transmitter output was connected to the spectrum analyzer via a cable and cable loss is used as the offset of the spectrum analyzer.



3. Set both RBW and VBW of spectrum analyzer to 100KHz with convenient frequency span including 100MHz bandwidth from lower band edge. Then detector set to peak and max hold this trace.
4. The lowest band edges emission was measured and recorded.
5. The transmitter set to the highest channel and repeated 2~4.

**Radiated Measurement**

1. Configure the EUT according to ANSI C63.4-2003
2. The turntable was rotated by 360 degrees to determine the position of the highest radiation.
3. The height of the broadband receiving antenna was varied between one meter and four meters above ground to find the maximum emission field strength of both horizontal and vertical polarization.
4. For band edge emission, the antenna tower was scan (from 1 M to 4 M) and then the turn table was rotated (from 0 degree to 360 degrees) to find the maximum reading.
5. For band edge emission, use 1MHz VBW and 1MHz RBW for reading under AV and use 1MHz VBW and 1MHz RBW for reading under PK.

**10.5 Test Result**

Temperature ( °C ) : 22~23	EUT: 2.4GHz Radio Control Computer System
Humidity (%RH) : 50~54	M/N: X-4S
Barometric Pressure ( mbar ) : 950~1000	Operation Condition: Tx Mode

**Radiated Test Result**

Frequency (MHz)	Antenna Polarization	Emission Read Value (dBµV/m)	Limits (dBµV/m)
2389.55	H	40.38	54
2389.55	V	43.22	54
2487.73	H	44.54	54
2487.73	V	42.88	54

Conducted Test Result  
Low Channel

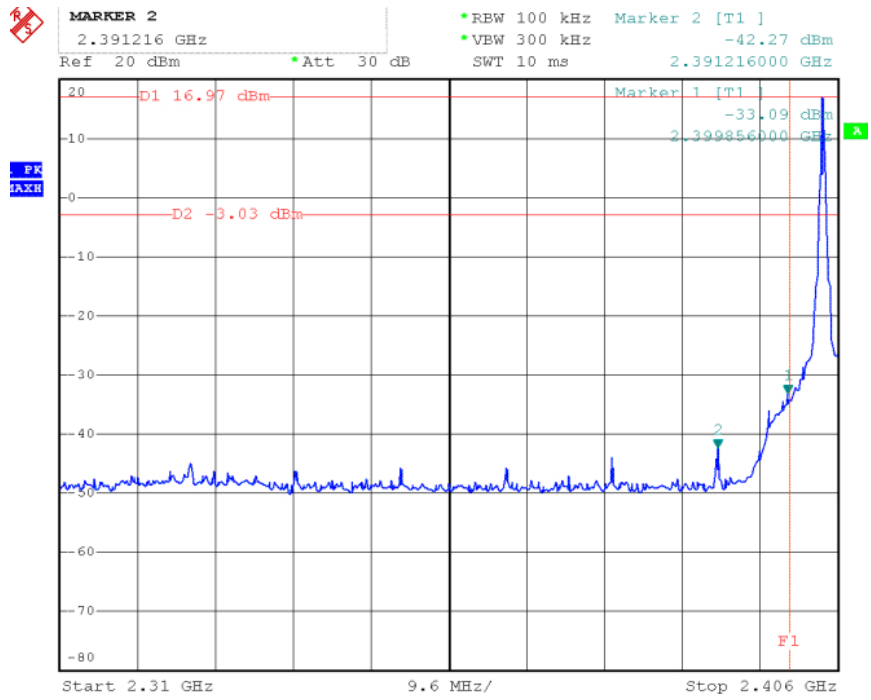

High Channel

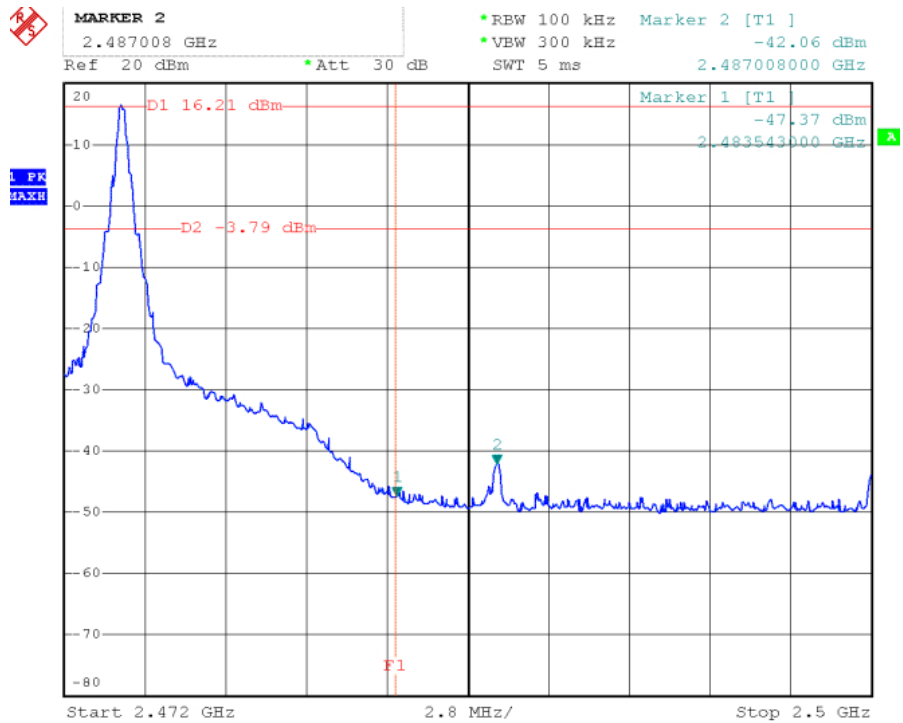

# 11. Test of Spurious Radiated Emission

## 11.1 Applicable Standard

Section 15.247(d): In any 100 kHz bandwidth outside the frequency band in which the spread spectrum or digitally modulated intentional radiator is operating, the radio frequency power that is produced by the intentional radiator shall be at least 20 dB below that in the 100 kHz bandwidth within the band that contains the highest level of the desired power, based on either an RF conducted or a radiated measurement. In addition, radiated emissions that fall in the restricted bands, as defined in Section 15.205, must also comply with the radiated emission limits specified in Section 15.209.

## 11.2 EUT Setup

### Conducted Measurement Setup

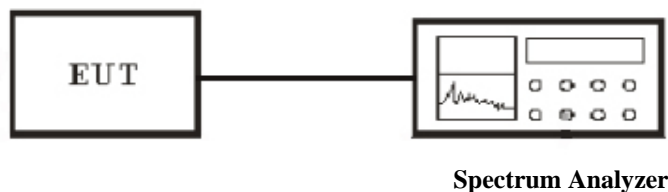

### Radiated Measurement Setup

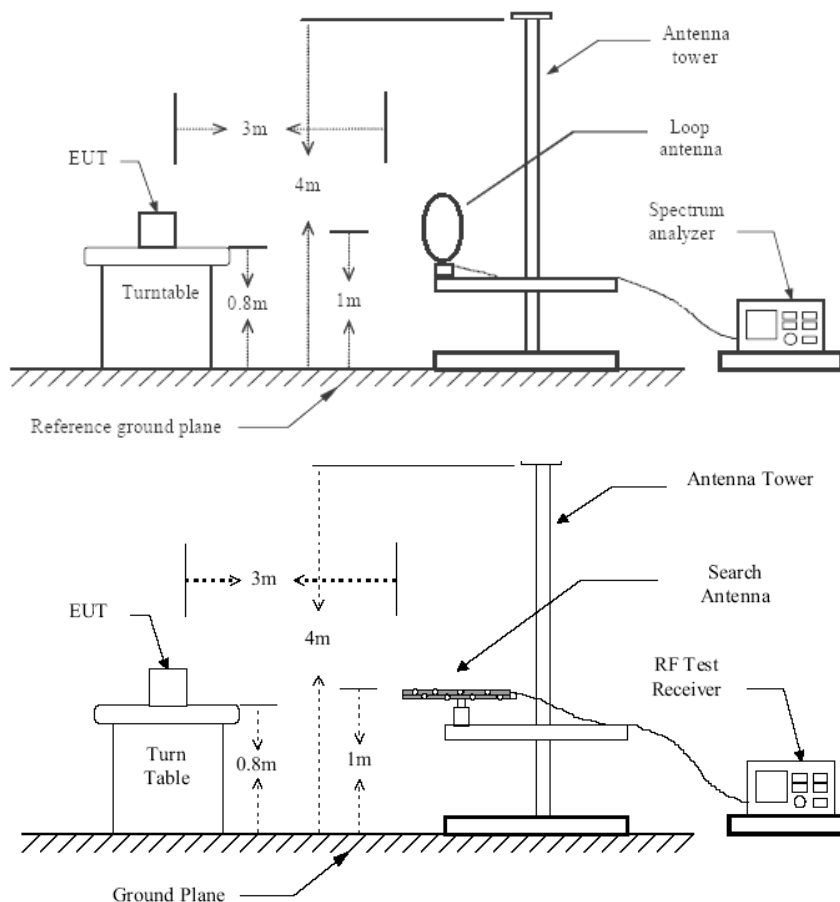

Figure 1 : Frequencies measured below 1 GHz configuration

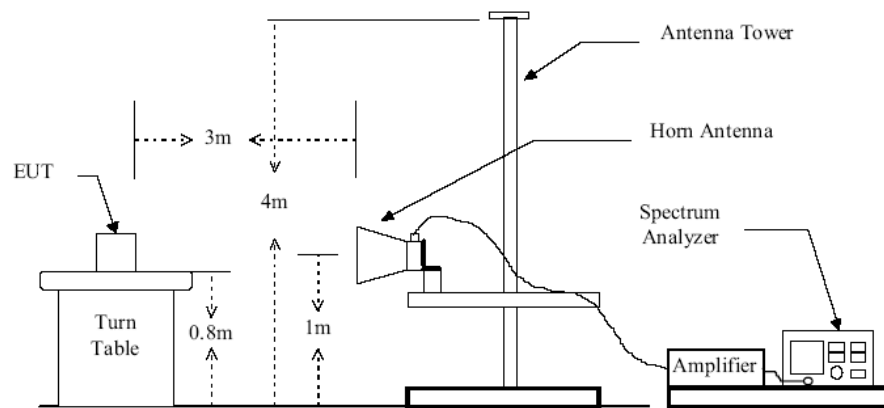

Figure 2 : Frequencies measured above 1 GHz configuration

### 11.3 Test Equipment List and Details

See section 2.5.

### 11.4 Test Procedure

#### Conducted Measurement

1. For emission above 1GHz to 26G,conducted measurement method is used.
2. The transmitter is set to the lowest channel.
3. The transmitter output was connected to the spectrum analyzer via a cable and cable loss is used as the offset of the spectrum analyzer.
4. Set RBW to 1 MHz and VBW to 3 MHz, Then detector set to peak and max hold this trace.
5. The lowest band edges emission was measured and recorded.
6. The transmitter set to the highest channel and repeated 2~4.

#### Radiated Measurement

1. Configure the EUT according to ANSI C63.4-2003
2. The EUT was placed on the top of the turntable 0.8 meter above ground.
3. Receiving antenna mounted on the top of a height-variable antenna tower was placed 3 meters far away from the turntable. When the frequency spectrum measured started from 9 kHz to 30 MHz, a loop antenna is used. When the frequency spectrum measured started from 30 MHz to 1000 MHz and above 1000 MHz, a broadband receiving antenna and the horn antenna are used.
4. Power on the EUT and all the supporting units.
5. The turntable was rotated by 360 degrees to determine the position of the highest radiation.
6. The height of the broadband receiving antenna was varied between one meter and four meters above ground to find the maximum emission field strength of both horizontal and vertical polarization.
7. For each suspected emission, the antenna tower was scanned (from 1 M to 4 M) and then the turntable was rotated (from 0 degree to 360 degrees) to find the maximum reading.

8. According to the characteristic of the EUT crystals, the range of frequencies was investigated from 9KHz to 30MHz, 30MHz to 1GHz and 1GHz to 26GHz.

9. For emission below 1GHz, Set the test-receiver system to Peak or CISPR quasi-peak Detect Function with specified bandwidth under Maximum Hold Mode.

10. For emission above 1GHz, Set the RBW=1MHz,VBW=3MHz for Peak Detector while the RBW=1MHz, VBW=10Hz for Average Detector, Readings are both peak and average values.

11. The pre-test have done for the EUT in three axes and found the worst emission at position shown in test setup photos. The worst case data is recorded in the report. All emission not reported are much lower than the prescribed limits.

### 11.5 Test Result

Temperature ( °C ) : 22~23	EUT: 2.4GHz Radio Control Computer System
Humidity (%RH) : 50~54	M/N: X-4S
Barometric Pressure ( mbar ) : 950~1000	Operation Condition: TX Mode

Radiated Spurious Emission Data Below 1GHz Channel Low:

EUT: 2.4GHz Radio Control Computer System  
M/N: X-4S  
Operating Condition: TX Mode  
Test Site: 3m CHAMBER  
Operator: Chen  
Test Specification: DC 6V from battery  
Comment: Polarization: Horizontal

**SWEEP TABLE: "test (30M-1G)"**

Short Description:		Field Strength			
Start	Stop	Detector	Meas. Time	IF Bandw.	Transducer
Frequency	Frequency				
30.0 MHz	1.0 GHz	MaxPeak	Coupled	100 kHz	VULB9163 NEW

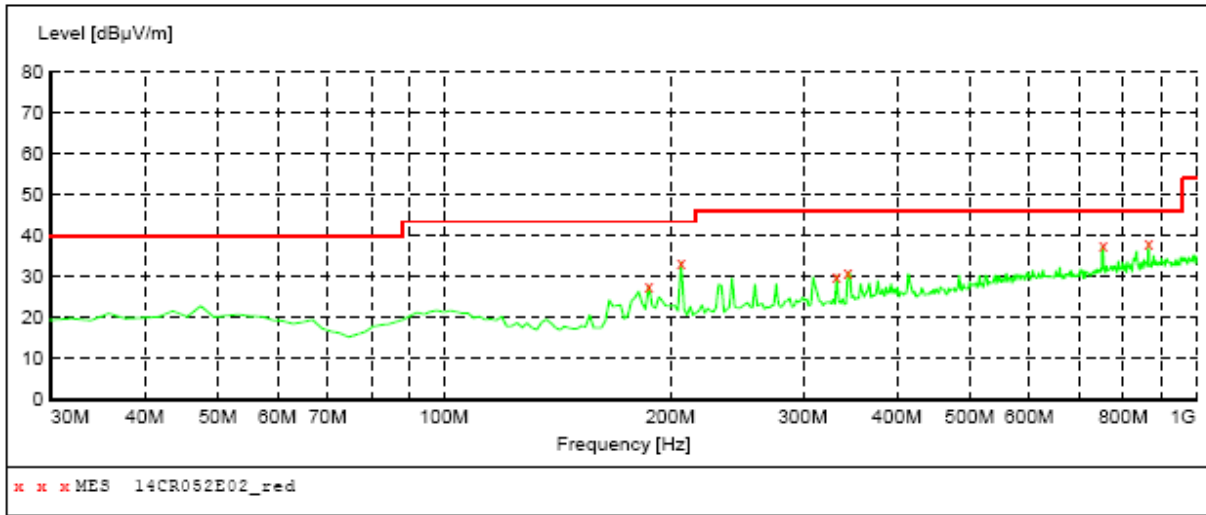

**MEASUREMENT RESULT: "14CR052E02\_red"**

3/28/2014 09:49

Frequency MHz	Level dBuV/m	Transd dB	Limit dBuV/m	Margin dB	Det.	Height cm	Azimuth deg	Polarization
187.140000	27.90	14.5	43.5	15.6	QP	100.0	0.00	HORIZONTAL
206.540000	33.60	15.0	43.5	9.9	QP	100.0	0.00	HORIZONTAL
332.640000	30.30	19.8	46.0	15.7	QP	100.0	0.00	HORIZONTAL
344.280000	31.30	20.3	46.0	14.7	QP	100.0	0.00	HORIZONTAL
751.680000	37.60	27.3	46.0	8.4	QP	100.0	0.00	HORIZONTAL
864.200000	38.40	28.8	46.0	7.6	QP	100.0	0.00	HORIZONTAL

Radiated Spurious Emission Data Below 1GHz Channel Low:

EUT: 2.4GHz Radio Control Computer System  
M/N: X-4S  
Operating Condition: TX Mode  
Test Site: 3m CHAMBER  
Operator: Chen  
Test Specification: DC 6V from battery  
Comment: Polarization: Vertical

**SWEEP TABLE: "test (30M-1G)"**

Short Description:		Field Strength				Transducer
Start	Stop	Detector	Meas. Time	IF Bandw.		
30.0 MHz	1.0 GHz	MaxPeak	Coupled	100 kHz	VULB9163 NEW	

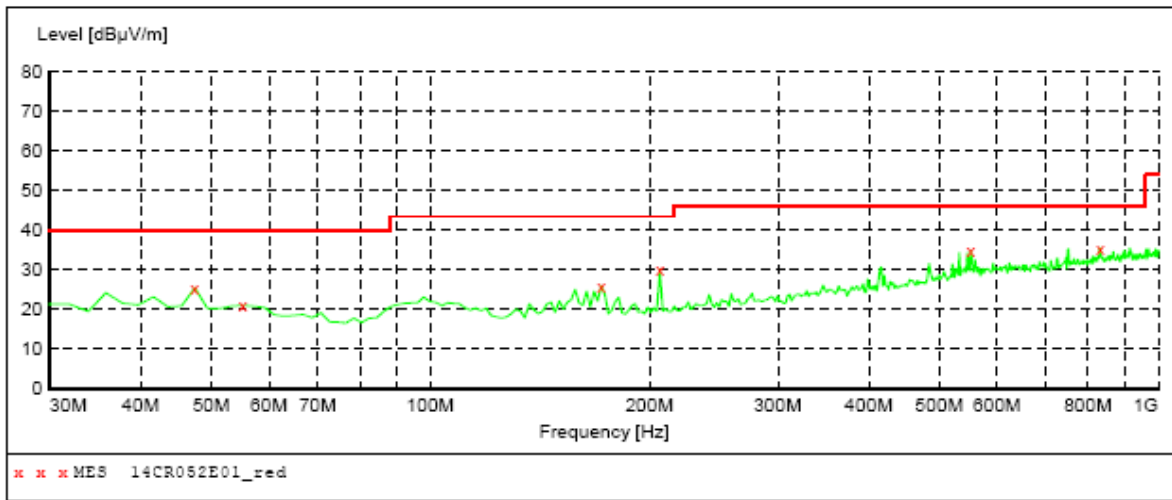

**MEASUREMENT RESULT: "14CR052E01\_red"**

3/28/2014 09:48

Frequency MHz	Level dBuV/m	Transd dB	Limit dBuV/m	Margin dB	Det.	Height cm	Azimuth deg	Polarization
47.460000	25.50	15.8	40.0	14.5	QP	100.0	0.00	VERTICAL
55.220000	21.00	15.6	40.0	19.0	QP	100.0	0.00	VERTICAL
171.620000	26.00	13.2	43.5	17.5	QP	100.0	0.00	VERTICAL
206.540000	29.90	15.0	43.5	13.6	QP	100.0	0.00	VERTICAL
551.860000	35.00	25.0	46.0	11.0	QP	100.0	0.00	VERTICAL
831.220000	35.50	28.4	46.0	10.5	QP	100.0	0.00	VERTICAL

Radiated Spurious Emission Data Below 1GHz Channel Middle:

EUT: 2.4GHz Radio Control Computer System  
M/N: X-4S  
Operating Condition: TX Mode  
Test Site: 3m CHAMBER  
Operator: Chen  
Test Specification: DC 6V from battery  
Comment: Polarization: Horizontal

**SWEEP TABLE: "test (30M-1G)"**

Short Description:		Field Strength			
Start	Stop	Detector	Meas.	IF	Transducer
Frequency	Frequency		Time	Bandw.	
30.0 MHz	1.0 GHz	MaxPeak	Coupled	100 kHz	VULB9163 NEW

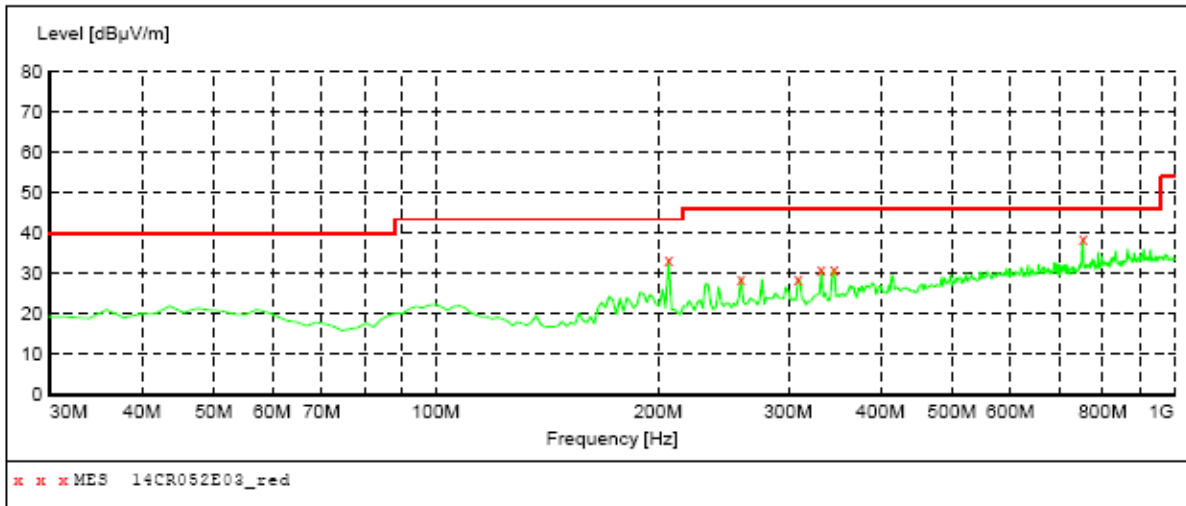

**MEASUREMENT RESULT: "14CR052E03\_red"**

3/28/2014 09:45

Frequency MHz	Level dBµV/m	Transd dB	Limit dBµV/m	Margin dB	Det.	Height cm	Azimuth deg	Polarization
206.540000	33.50	15.0	43.5	10.0	QP	100.0	0.00	HORIZONTAL
258.920000	28.90	17.3	46.0	17.1	QP	100.0	0.00	HORIZONTAL
309.360000	28.90	18.9	46.0	17.1	QP	100.0	0.00	HORIZONTAL
332.640000	31.00	19.8	46.0	15.0	QP	100.0	0.00	HORIZONTAL
346.220000	31.20	20.3	46.0	14.8	QP	100.0	0.00	HORIZONTAL
751.680000	38.50	27.3	46.0	7.5	QP	100.0	0.00	HORIZONTAL



Radiated Spurious Emission Data Below 1GHz Channel Middle:

EUT: 2.4GHz Radio Control Computer System  
M/N: X-4S  
Operating Condition: TX Mode  
Test Site: 3m CHAMBER  
Operator: Chen  
Test Specification: DC 6V from battery  
Comment: Polarization: Vertical

**SWEEP TABLE: "test (30M-1G)"**

Short Description:		Field Strength			
Start	Stop	Detector	Meas. Time	IF Bandw.	Transducer
Frequency	Frequency	MaxPeak	Coupled	100 kHz	VULB9163 NEW
30.0 MHz	1.0 GHz				

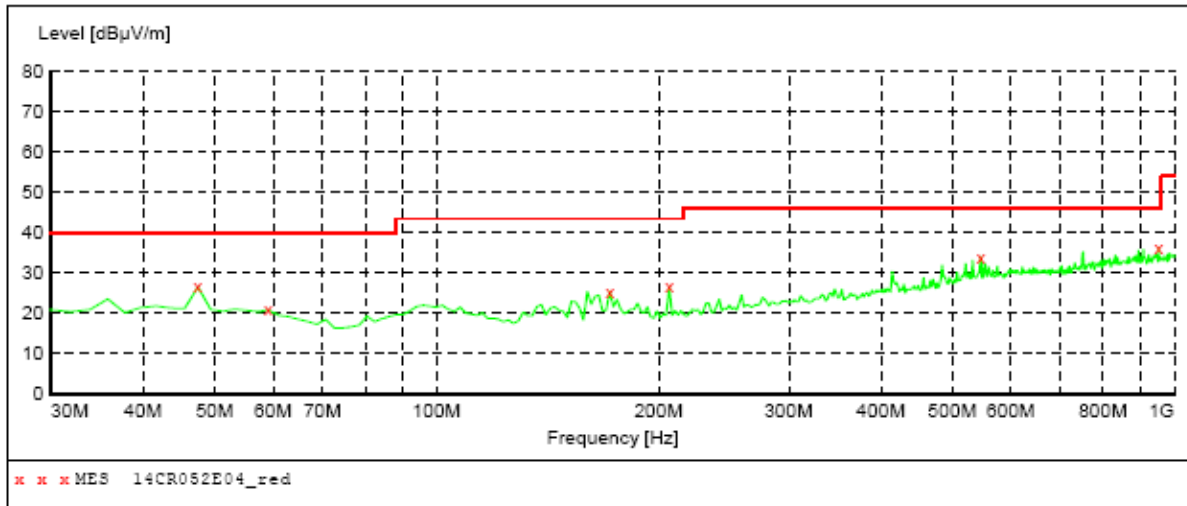

**MEASUREMENT RESULT: "14CR052E04\_red"**

3/28/2014 09:47

Frequency MHz	Level dBµV/m	Transd dB	Limit dBµV/m	Margin dB	Det.	Height cm	Azimuth deg	Polarization
47.460000	26.60	15.8	40.0	13.4	QP	100.0	0.00	VERTICAL
59.100000	20.90	14.6	40.0	19.1	QP	100.0	0.00	VERTICAL
171.620000	25.50	13.2	43.5	18.0	QP	100.0	0.00	VERTICAL
206.540000	26.60	15.0	43.5	16.9	QP	100.0	0.00	VERTICAL
546.040000	34.10	24.9	46.0	11.9	QP	100.0	0.00	VERTICAL
951.500000	36.30	29.6	46.0	9.7	QP	100.0	0.00	VERTICAL

Radiated Spurious Emission Data Below 1GHz Channel High:

EUT: 2.4GHz Radio Control Computer System  
M/N: X-4S  
Operating Condition: TX Mode  
Test Site: 3m CHAMBER  
Operator: Chen  
Test Specification: DC 6V from battery  
Comment: Polarization: Horizontal

**SWEEP TABLE: "test (30M-1G)"**

Short Description:		Field Strength			
Start	Stop	Detector	Meas. Time	IF Bandw.	Transducer
Frequency	Frequency				
30.0 MHz	1.0 GHz	MaxPeak	Coupled	100 kHz	VULB9163 NEW

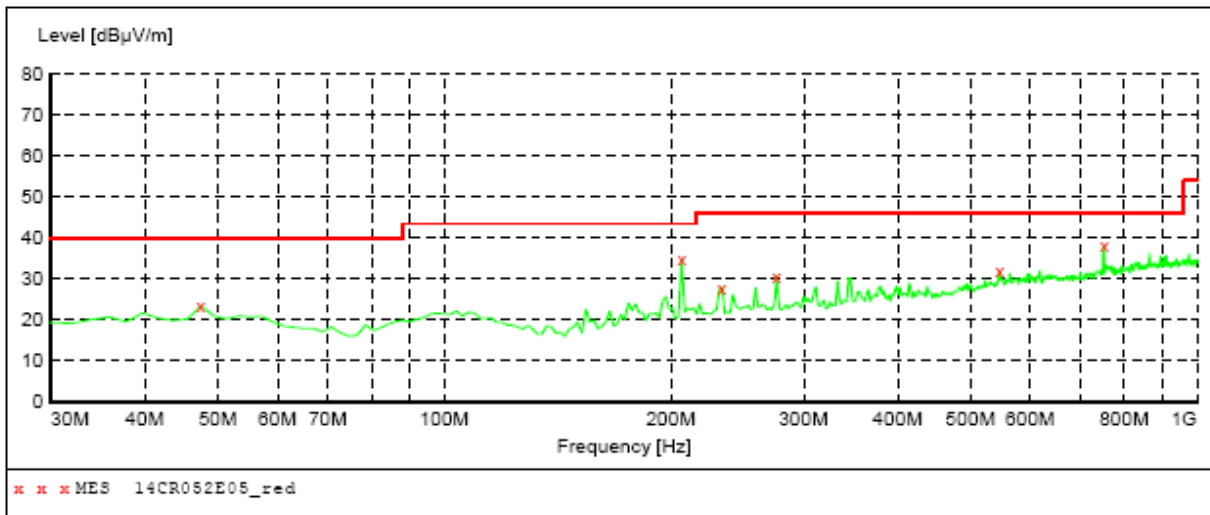

**MEASUREMENT RESULT: "14CR052E05\_red"**

3/28/2014 09:51

Frequency MHz	Level dBuV/m	Transd dB	Limit dBuV/m	Margin dB	Det.	Height cm	Azimuth deg	Polarization
47.460000	23.40	15.8	40.0	16.6	QP	100.0	0.00	HORIZONTAL
206.540000	34.80	15.0	43.5	8.7	QP	100.0	0.00	HORIZONTAL
233.700000	28.00	16.4	46.0	18.0	QP	100.0	0.00	HORIZONTAL
276.380000	30.80	18.0	46.0	15.2	QP	100.0	0.00	HORIZONTAL
546.040000	31.80	24.9	46.0	14.2	QP	100.0	0.00	HORIZONTAL
751.680000	38.10	27.3	46.0	7.9	QP	100.0	0.00	HORIZONTAL

Radiated Spurious Emission Data Below 1GHz Channel High:

EUT: 2.4GHz Radio Control Computer System  
M/N: X-4S  
Operating Condition: TX Mode  
Test Site: 3m CHAMBER  
Operator: Chen  
Test Specification: DC 6V from battery  
Comment: Polarization: Vertical

**SWEEP TABLE: "test (30M-1G)"**

Short Description:		Field Strength			
Start	Stop	Detector	Meas. Time	IF Bandw.	Transducer
Frequency	Frequency				
30.0 MHz	1.0 GHz	MaxPeak	Coupled	100 kHz	VULB9163 NEW

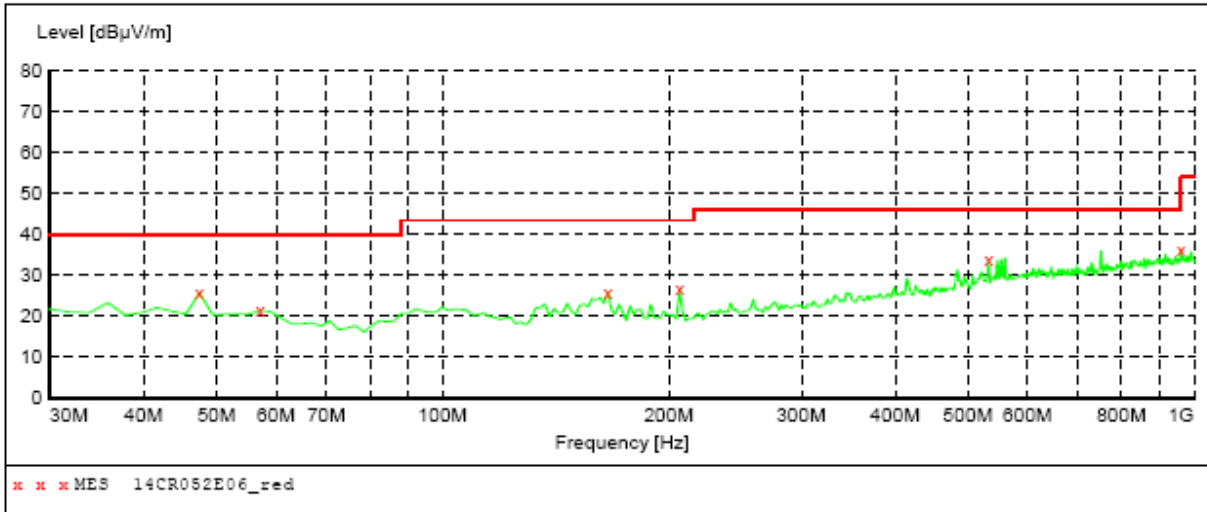

**MEASUREMENT RESULT: "14CR052E06\_red"**

3/28/2014 09:52

Frequency MHz	Level dBµV/m	Transd dB	Limit dBµV/m	Margin dB	Det.	Height cm	Azimuth deg	Polarization
47.460000	25.80	15.8	40.0	14.2	QP	100.0	0.00	VERTICAL
57.160000	21.40	15.1	40.0	18.6	QP	100.0	0.00	VERTICAL
165.800000	26.00	13.0	43.5	17.5	QP	100.0	0.00	VERTICAL
206.540000	26.60	15.0	43.5	16.9	QP	100.0	0.00	VERTICAL
532.460000	33.90	24.6	46.0	12.1	QP	100.0	0.00	VERTICAL
959.260000	36.50	29.6	46.0	9.5	QP	100.0	0.00	VERTICAL

Radiated Spurious Emission Test Data Above 1GHz

Channel Low

Channel Low (2404.056MHz)								
Maximum Frequency (MHz)	Polarity and Level					Limit (dBµV/m)	Margin (dBµV/m)	Mark (P/Q/A)
	Polarity	Height (m)	Reading dBµV	Transd	Result dBµV/m			
2404.056	H	1	111.02	-7.15	103.87	N/A	N/A	P
			102.42	-7.15	95.27	N/A	N/A	A
2404.056	V	1	113.45	-7.15	106.3	N/A	N/A	P
			102.56	-7.15	95.41	N/A	N/A	A
4808.112	H	1	40.06	1.07	41.13	74	-32.87	P
			29.92	1.07	30.99	54	-23.01	A
4808.112	V	1	41.41	1.07	42.48	74	-31.52	P
			30.56	1.07	31.63	54	-22.37	A
7205	H	1	40.19	7.38	47.57	74	-26.43	P
			30.36	7.38	37.74	54	-16.26	A
7205	V	1	42.05	7.38	49.43	74	-24.57	P
			31.43	7.38	38.81	54	-15.19	A
9613.33	H	1	40.12	10.29	50.41	74	-23.59	P
			30.9	10.29	41.19	54	-12.81	A
9613.33	V	1	42.61	7.38	49.99	74	-24.01	P
			31.28	7.38	38.66	54	-15.34	A
12021.67	H	1	40.26	14.01	54.27	74	-19.73	P
			31.45	14.01	45.46	54	-8.54	A
12021.67	V	1	41.25	14.01	55.26	74	-18.74	P
			31.36	14.01	45.37	54	-8.63	A
25380.37	----	----	----	----	----	----	----	----

Remark: 1. Transd.=Antenna Factor+Cable Loss-Pre-amplifier  
 Margin = Level-Limit  
 Mark: P means Peak Value, Q means Quasi Peak Value, A means Average Value  
 2. Data of measurement within this frequency range shown “-” in the table above means the reading of emissions are attenuated more than 20dB below the permissible limits or the field strength is too small to be measured.  
 3. Spectrum analyzer setting P(Peak): RBW=1MHz, VBW=1MHz, A(Average): RBW=1MHz, VBW=10Hz.  
 4. The test limit distance is 3m limit

Channel Mid

Channel Low (2440.561MHz)								
Maximum Frequency (MHz)	Polarity and Level					Limit (dBµV/m)	Margin (dBµV/m)	Mark (P/Q/A)
	Polarity	Height (m)	Reading dBµV	Transd	Result dBµV/m			
2438.553	H	1	109.01	-6.37	102.64	N/A	N/A	P
			100.25	-6.37	93.88	N/A	N/A	A
2438.553	V	1	112.36	-6.37	105.99	N/A	N/A	P
			102.13	-6.37	95.76	N/A	N/A	A
4877.106	H	1	39.92	1.07	40.99	74	-33.01	P
			30.05	1.07	31.12	54	-22.88	A
4877.106	V	1	41.26	1.07	42.33	74	-31.67	P
			30.52	1.07	31.59	54	-22.41	A
7315.659	H	1	39.75	7.49	47.24	74	-26.76	P
			30.41	7.49	37.9	54	-16.1	A
7315.659	V	1	41.19	7.49	48.68	74	-25.32	P
			31.03	7.49	38.52	54	-15.48	A
9754.212	H	1	40.42	10.47	50.89	74	-23.11	P
			31.05	10.47	41.52	54	-12.48	A
9754.212	V	1	40.76	10.47	51.23	74	-22.77	P
			31.19	10.47	41.66	54	-12.34	A
12192.85	H	1	41.05	14.1	55.15	74	-18.85	P
			30.73	14.1	44.83	54	-9.17	A
12192.85	V	1	41.26	14.1	55.36	74	-18.64	P
			31.41	14.1	45.51	54	-8.49	A
25380.37	----	----	----	----	----	----	----	----

Remark: 1. Transd.=Antenna Factor+Cable Loss-Pre-amplifier  
 Margin = Level-Limit  
 Mark: P means Peak Value, Q means Quasi Peak Value, A means Average Value  
 2. Data of measurement within this frequency range shown “-” in the table above means the reading of emissions are attenuated more than 20dB below the permissible limits or the field strength is too small to be measured.  
 3. Spectrum analyzer setting P(Peak): RBW=1MHz, VBW=1MHz, A(Average): RBW=1MHz, VBW=10Hz.  
 4. The test limit distance is 3m limit

Channel High

Channel Low (2479.095MHz)								
Maximum Frequency (MHz)	Polarity and Level					Limit (dBµV/m)	Margin (dBµV/m)	Mark (P/Q/A)
	Polarity	Height (m)	Reading dBµV	Transd	Result dBµV/m			
2474.025	H	1	112.21	-6.05	106.16	N/A	N/A	P
			103.34	-6.05	97.29	N/A	N/A	A
2474.025	V	1	113.92	-6.05	107.87	N/A	N/A	P
			103.56	-6.05	97.51	N/A	N/A	A
4948.05	H	1	40.52	1.07	41.59	74	-32.41	P
			30.41	1.07	31.48	54	-22.52	A
4948.05	V	1	41.36	1.07	42.43	74	-31.57	P
			30.5	1.07	31.57	54	-22.43	A
7422.075	H	1	41.36	7.61	48.97	74	-25.03	P
			30.19	7.61	37.8	54	-16.2	A
7422.075	V	1	40.7	7.61	48.31	74	-25.69	P
			31.41	7.61	39.02	54	-14.98	A
9896.1	H	1	40.36	10.65	51.01	74	-22.99	P
			31.19	10.65	41.84	54	-12.16	A
9896.1	V	1	40.84	10.65	51.49	74	-22.51	P
			31.05	10.65	41.7	54	-12.3	A
12351.54	H	1	40.36	14.19	54.55	74	-19.45	P
			31.19	14.19	45.38	54	-8.62	A
12351.54	V	1	40.79	14.19	54.98	74	-19.02	P
			31.56	14.19	45.75	54	-8.25	A
25381.35	----	----	----	----	----	----	----	----

Remark: 1. Transd.=Antenna Factor+Cable Loss-Pre-amplifier  
 Margin = Level-Limit  
 Mark: P means Peak Value, Q means Quasi Peak Value, A means Average Value  
 2. Data of measurement within this frequency range shown “-” in the table above means the reading of emissions are attenuated more than 20dB below the permissible limits or the field strength is too small to be measured.  
 3. Spectrum analyzer setting P(Peak): RBW=1MHz, VBW=1MHz, A(Average): RBW=1MHz, VBW=10Hz.  
 4. The test limit distance is 3m limit

Radiated Emission Below 30 MHz

Frequency (MHz)	Read Level (dBuV)	Antenna Factor (dB/m)	Cable Loss (dB)	Emission Levels (dBuV/m)	Limit (dBμV/m)	Margin (dB)	Detector Mode
0.788	24.91	8.22	-1.01	32.12	67	-34.88	QP
18.74	25.07	8.17	-1.2	32.04	49.5	-17.46	QP
23.96	23.25	8.03	-1.05	30.23	49.5	-19.27	QP
24.61	24.61	7.48	-1.69	30.4	49.5	-19.1	QP

Note:

1. The pre-test have done for the EUT in three axes and found the worst emission at position shown in test setup photos. The worst case data is recorded in the report.
2. Emission level (dBuV/m) =Raw Value (dBuV) + Correction Factor (dB/m)
3. Correction Factor (dB/m) = Antenna Factor (dB/m) + Cable Factor (dB)
4. The other emission levels were very low against the limit.
5. Margin value = Emission level.- Limit value

Conducted Spurious Emission Test Data 30MHz-26.5GHz  
Channel Low

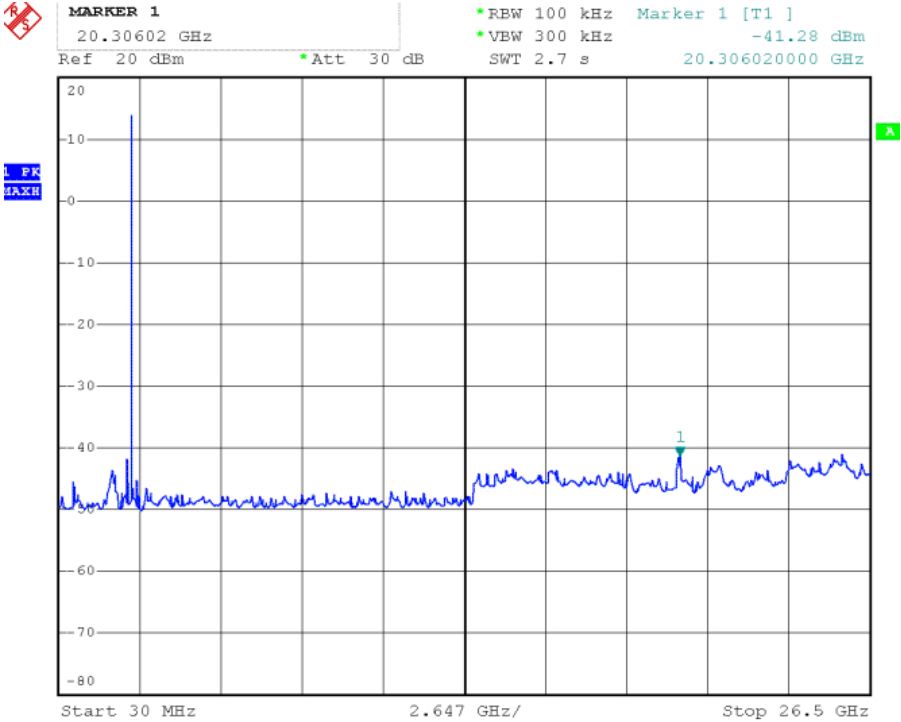

Channel Mid

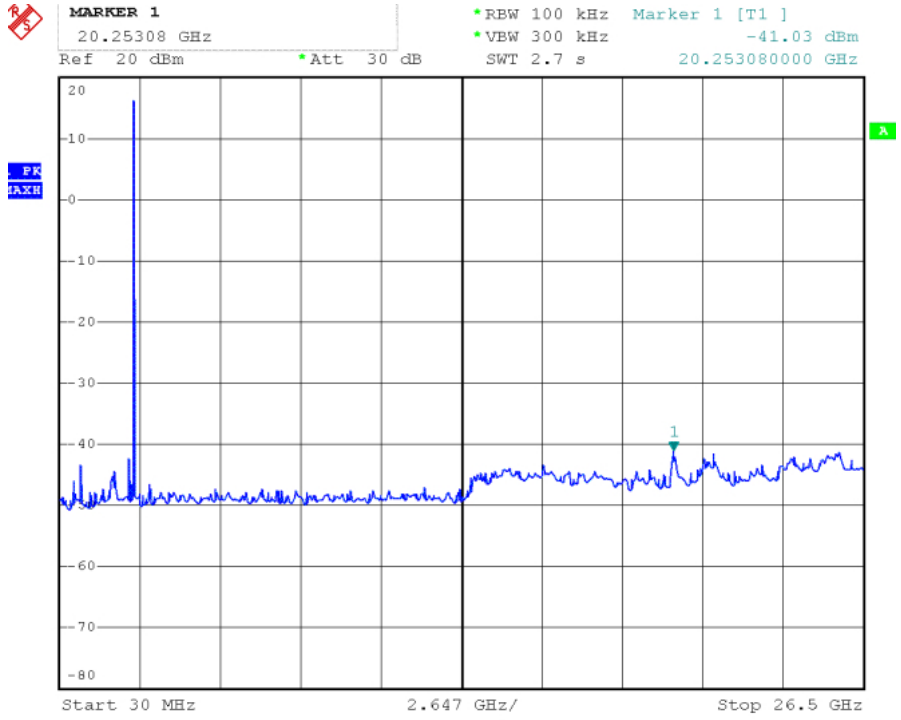



# Channel High

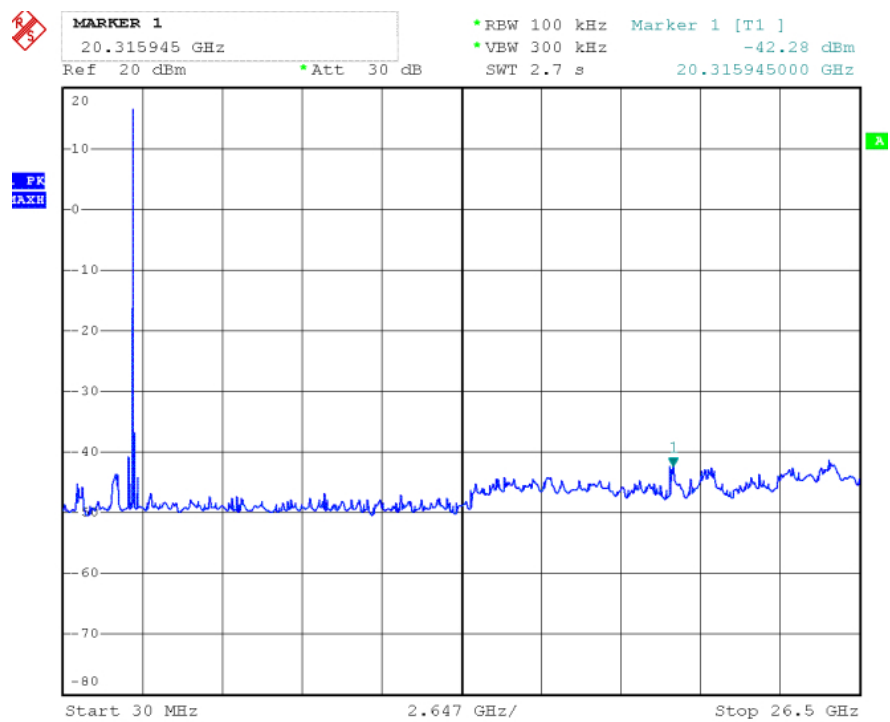

## **12. ANTENNA REQUIREMENT**

### **12.1 Standard Applicable**

Section 15.203:

An intentional radiator shall be designed to ensure that no antenna other than that furnished by the responsible party shall be used with the device. The use of a permanently attached antenna or of an antenna that uses a unique coupling to the intentional radiator shall be considered sufficient to comply with the provisions of this Section. The manufacturer may design the unit so that a broken antenna can be replaced by the user, but the use of a standard antenna jack or electrical connector is prohibited.

Section 15.247(b)/(c):

If transmitting antennas of directional gain greater than 6 dBi are used, the peak output power from the intentional radiator shall be reduced by the amount in dB that the directional gain of the antenna exceeds 6 dBi.

If the intentional radiator is used exclusively for fixed, point-to-point operations may employ transmitting antennas with directional gain greater than 6 dBi provided the maximum peak output power of the intentional radiator is reduced by 1 dB for every 3 dB that the directional gain of the antenna exceeds 6 dBi.

### **12.2 Antenna Connected Construction**

The antenna connector is designed with permanent attachment and no consideration of replacement. The antenna used in this product is complied with Standard. The maximum Gain of the antenna lower than 6.0dBi and have the definite antenna Specification.