



Prüfbericht-Nr.: <i>Test report no.:</i>	CN20H36H(P15C-BLE) 001	Auftrags-Nr.: <i>Order no.:</i>	238491014	Seite 1 von 24 Page 1 of 24	
Kunden-Referenz-Nr.: <i>Client reference no.:</i>	N/A	Auftragsdatum: <i>Order date:</i>	2020-09-02		
Auftraggeber: <i>Client:</i>	Eve Systems LLC 100 Pine St., Suite 1250, San Francisco CA 94111 USA				
Prüfgegenstand: <i>Test item:</i>	Eve Weather				
Bezeichnung / Typ-Nr.: <i>Identification / Type no.:</i>	20EBS9901				
Auftrags-Inhalt: <i>Order content:</i>	FCC Part 15C Test report (BLE)				
Prüfgrundlage: <i>Test specification:</i>	FCC 47CFR Part 15: Subpart C Section 15.247				
Wareneingangsdatum: <i>Date of sample receipt:</i>	2020-11-06				
Prüfmuster-Nr.: <i>Test sample no.:</i>	A002944173-010 A002944173-016				
Prüfzeitraum: <i>Testing period:</i>	2020-11-10 - 2020-11-16				
Ort der Prüfung: <i>Place of testing:</i>	EMC/RF Taipei Testing Site				
Prüflaboratorium: <i>Testing laboratory:</i>	Taipei Testing Laboratories				
Prüfergebnis*: <i>Test result*:</i>	Pass				
überprüft von: <i>reviewed by:</i>	 Mars Lin		genehmigt von: <i>authorized by:</i>	 Brenda Chen	
Datum: <i>Date:</i>	2020-11-26		Ausstellungsdatum: <i>Issue date:</i>	2020-11-26	
Stellung / Position:	Senior Project Engineer		Stellung / Position:	Senior Project Manager	
Sonstiges / Other:					
Zustand des Prüfgegenstandes bei Anlieferung: <i>Condition of the test item at delivery:</i>		Prüfmuster vollständig und unbeschädigt <i>Test item complete and undamaged</i>			
* Legende:	1 = sehr gut P(ass) = entspricht o.g. Prüfgrundlage(n)	2 = gut F(ail) = entspricht nicht o.g. Prüfgrundlage(n)	3 = befriedigend F(ail) = entspricht nicht o.g. Prüfgrundlage(n)	4 = ausreichend N/A = nicht anwendbar	5 = mangelhaft N/T = nicht getestet
* Legend:	1 = very good P(ass) = passed a.m. test specification(s)	2 = good F(ail) = failed a.m. test specification(s)	3 = satisfactory F(ail) = failed a.m. test specification(s)	4 = sufficient N/A = not applicable	5 = poor N/T = not tested
Dieser Prüfbericht bezieht sich nur auf das o.g. Prüfmuster und darf ohne Genehmigung der Prüfstelle nicht auszugsweise vervielfältigt werden. Dieser Bericht berechtigt nicht zur Verwendung eines Prüfzeichens. <i>This test report only relates to the a. m. test sample. Without permission of the test center this test report is not permitted to be duplicated in extracts. This test report does not entitle to carry any test mark.</i>					

TEST SUMMARY

Report Section	FCC Clause	Test Item	Result
5.1.1	15.247(b) & 15.203	Antenna Requirement	Pass
5.1.2	15.247(b)(3)	Peak Output Power	Pass
5.1.3	15.247(a)(2)	6 dB Bandwidth	Pass
5.1.3	2.1049	99% Occupied Bandwidth	Pass
5.1.4	15.247(e)	Power Spectral Density	Pass
5.1.5	15.247(d)	Conducted Spurious Emissions and Band Edges	Pass
5.1.6	15.247(d) & 15.205 & 15.209	Radiated Spurious Emissions and Band Edges	Pass
-	15.207	Mains Conducted Emission	Not Applicable
-	FCC KDB 447498 D01 v06	RF Exposure Compliance	Refer to report no. CN20H36H(RFEXPOSURE) 001

Note: Determining compliance based on the results of the compliance measurement, not taking into account measurement instrumentation uncertainty.

Contents

HISTORY OF THIS TEST REPORT	5
1. GENERAL REMARKS	6
1.1 COMPLEMENTARY MATERIALS.....	6
1.2 DECISION RULE OF CONFORMITY	6
2. TEST SITES	7
2.1 TEST LABORATORY	7
2.2 TEST FACILITY.....	7
2.3 TRACEABILITY	8
2.4 CALIBRATION	8
2.5 MEASUREMENT UNCERTAINTY	8
3. GENERAL PRODUCT INFORMATION.....	9
3.1 PRODUCT FUNCTION AND INTENDED USE	9
3.2 SYSTEM DETAILS AND RATINGS.....	9
3.3 NOISE GENERATING AND NOISE SUPPRESSING PARTS	10
3.4 SUBMITTED DOCUMENTS.....	10
4. TEST SET-UP AND OPERATION MODES.....	11
4.1 PRINCIPLE OF CONFIGURATION SELECTION	11
4.2 CARRIER FREQUENCY AND CHANNEL.....	11
4.3 TEST OPERATION AND TEST SOFTWARE.....	12
4.4 SPECIAL ACCESSORIES AND AUXILIARY EQUIPMENT	13
4.5 TEST SETUP DIAGRAM	13
5. TEST RESULTS	14
5.1 TRANSMITTER REQUIREMENT & TEST SUITES	14
5.1.1 <i>Antenna Requirement</i>	<i>14</i>
5.1.2 <i>Peak Output Power</i>	<i>15</i>
5.1.3 <i>6 dB Bandwidth and 99% Occupied Bandwidth.....</i>	<i>17</i>
5.1.4 <i>Power Spectral Density.....</i>	<i>18</i>
5.1.5 <i>Conducted Spurious Emissions and Frequency Band Edges Measured in 100kHz Bandwidth.....</i>	<i>19</i>
5.1.6 <i>Radiated Spurious Emissions and Band Edges</i>	<i>20</i>

Prüfbericht - Nr.: CN20H36H(P15C-BLE) 001
Test Report No.

Seite 4 von 24
Page 4 of 24

APPENDIX A - TEST RESULT OF CONDUCTED

APPENDIX B - TEST RESULT OF RADIATED EMISSIONS & MAINS CONDUCTED EMISSION

APPENDIX SP - PHOTOGRAPHS OF TEST SETUP

APPENDIX EP - PHOTOGRAPHS OF EUT

Prüfbericht - Nr.: CN20H36H(P15C-BLE) 001
Test Report No.

Seite 5 von 24
Page 5 of 24

HISTORY OF THIS TEST REPORT

Report No.	Description	Date Issued
CN20H36H(P15C-BLE) 001	Original Release	2020-11-26

1. General Remarks

1.1 Complementary Materials

All attachments are integral parts of this test report. This applies especially to the following appendix:

Appendix A - Test Result of Conducted

Appendix B - Test Result of Radiated Emissions & Mains Conducted Emission

Appendix SP - Photographs of Test Setup

Appendix EP - Photographs of EUT

Applied Standard and Test Levels

Radio
FCC 47CFR Part 15: Subpart C Section 15.247
FCC 47CFR Part 2: Subpart J Section 2.1049
ANSI C63.10:2013
KDB 558074 D01 15.247 Meas Guidance v05r02
KDB 447498 D01 General RF Exposure Guidance v06

1.2 Decision Rule of Conformity

The decision rule of conformity of this test report is following the requirements of the requested standard in the quotation, and agreed among testing laboratory and manufacturer (applicant) to exclude the consideration of Measurement Uncertainty, unless it is required by the specific standard.

2. Test Sites

2.1 Test Laboratory

Taipei Testing Laboratories

11F. No.758, Sec. 4, Bade Rd., Songshan Dist.
Taipei City 105
Taiwan (R.O.C.)

2.2 Test Facility

Taipei Testing Laboratories

No.458-18, Sec. 2, Fenliao Rd., Linkou Dist.,
New Taipei City 244
Taiwan (R.O.C.)
FCC Registration No.: 226631
ISED Registration No.: 25563

2.3 Traceability

All measurement equipment calibrations are traceable to NML(Taiwan)/NIST(USA) or where calibration is performed outside Taiwan, to equivalent nationally recognized standards organizations.

2.4 Calibration

Equipment requiring calibration is calibrated periodically in a suitably accredited Calibration Lab. Additionally all equipment is verified for proper performance on a regular basis using in house standards or comparisons.

2.5 Measurement Uncertainty

All measurement uncertainty values are shown with a coverage factor of $k=2$ to indicate a 95% level of confidence.

Emission Measurement Uncertainty

Parameter	Uncertainty
Radiated Emission (9 kHz ~ 30 MHz)	± 1.15 dB
Radiated Emission (30 MHz ~ 200 MHz)	± 1.30 dB
Radiated Emission (200 MHz ~ 1 GHz)	± 1.30 dB
Radiated Emission (1 GHz ~ 18 GHz)	± 1.54 dB
Radiated Emission (18 GHz ~ 40 GHz)	± 2.52 dB
Mains Conducted Emission	± 1.65 dB

3. General Product Information

3.1 Product Function and Intended Use

The EUT is a Eve Weather. It contains a Bluetooth compatible module enabling the user to communicate data through a Wireless interface.

For details refer to the User Guide, Data Sheet and Circuit Diagram.

3.2 System Details and Ratings

Basic Information of EUT

Item	EUT information
Kind of Equipment/Test Item	Eve Weather
Type Identification	20EBS9901
FCC ID	SNE-WEATH-002

Technical Specification of EUT

Item	EUT information
Operating Frequency	2402 MHz ~ 2480 MHz
Channel Spacing	2 MHz
Channel number	40
Data Rate	1Mbps, 2Mbps
Operation Voltage	3Vdc from Battery
Modulation	GFSK
Maximum Output Power (mW)	4.86
Antenna Information	Refer to 5.1.1
Accessory Device	Refer to 4.4

3.3 Noise Generating and Noise Suppressing Parts

Refer to the Circuit Diagram.

3.4 Submitted Documents

- Circuit Diagram
- Instruction Manual
- Rating Label
- Technical Description

4. Test Set-up and Operation Modes

4.1 Principle of Configuration Selection

The test modes were adapted accordingly in reference to the instructions for use.

During testing, Channel and Power Controlling Software provided by the customer was used to control the operating channel as well as the output power level. The RF output power selection is for the setting of RF output expected by the customer and is going to be fixed on the firmware of the final end product.

Table for Parameters of Test Software Setting

Frequency (MHz)	Power Setting	
	BLE 1M	BLE 2M
2402	8	8
2440	6	7
2480	7	7

4.2 Carrier Frequency and Channel

Channel	Freq. (MHz)	Channel	Freq. (MHz)	Channel	Freq. (MHz)	Channel	Freq. (MHz)
0	2402	10	2422	20	2442	30	2462
1	2404	11	2424	21	2444	31	2464
2	2406	12	2426	22	2446	32	2466
3	2408	13	2428	23	2448	33	2468
4	2410	14	2430	24	2450	34	2470
5	2412	15	2432	25	2452	35	2472
6	2414	16	2434	26	2454	36	2474
7	2416	17	2436	27	2456	37	2476
8	2418	18	2438	28	2458	38	2478
9	2420	19	2440	29	2460	39	2480

4.3 Test Operation and Test Software

Setup for testing: Test samples are provided with a USB interface which makes it possible to control them through a test software installed on a notebook computer.

This software was running on the laptop computer connected to the EUT. It was used to enable the operation modes listed as below.

Test Software	nRF_DTM.exe
---------------	-------------

The samples were used as follows:

A002944173-010 for radiated

A002944173-016 for conducted

Full test was applied on all test modes, but only worst case was shown.

EUT Configure Mode	Applicable To			Mains Conducted Emission	Description
	Antenna Port Conducted Measurement	Radiated Spurious Emissions above 1 GHz	Radiated Spurious Emissions below 1 GHz		
-	√	√	√	-	-

Note:

1. The EUT had been pre-tested on the positioned of each 3 axis. The worst case was found when position on Z-plane.
2. "-" means no effect.

Antenna Port Conducted Measurement

Pre-Scan full test was applied on all test modes, but only worst case was shown.

Following channel(s) was (were) selected for the final test as listed below.

EUT Configure Mode	Available Frequency (MHz)	Tested Frequency (MHz)	Date Rate (Mbps)
-	2402 to 2480	2402, 2440, 2480	1
-	2402 to 2480	2402, 2440, 2480	2

Radiated Spurious Emissions (Above 1 GHz)

Pre-Scan full test was applied on all test modes, but only worst case was shown.

Following channel(s) was (were) selected for the final test as listed below.

EUT Configure Mode	Available Frequency (MHz)	Tested Frequency (MHz)	Date Rate (Mbps)
-	2402 to 2480	2402, 2440, 2480	1
-	2402 to 2480	2402, 2440, 2480	2

Radiated Spurious Emissions (Below 1 GHz)

Pre-Scan full test was applied on all test modes, but only worst case was shown.

Following channel(s) was (were) selected for the final test as listed below.

EUT Configure Mode	Available Frequency (MHz)	Tested Frequency (MHz)	Date Rate (Mbps)
-	2402 to 2480	2440	2

Test Condition

Test Item	Ambient Temperature	Relative Humidity	Tested by
Conducted Measurement	24.5 °C	57.9 %	Aslen Chiu
Radiated Spurious Emissions above 1 GHz	22.8~23.8 °C	58.5~59.7 %	Simom Tsai
Radiated Spurious Emissions below 1 GHz	22.8~23.8 °C	58.5~59.7 %	Simom Tsai

4.4 Special Accessories and Auxiliary Equipment

The product has been tested together with the following additional accessories:

Accessory of EUT

None.

Support Unit

No.	Description	Brand	Model	S/N	Remark
1	UART	N/A	CP2102	-	Radiated Test
2	Nootebook	HP	15s-du0007TX	CND93662VF	
3	Adapter	HP	TPN-CA16	-	
-	Notebook	HP	TPN-139	CND93662WT	Conducted Test

4.5 Test Setup Diagram

<Radiated Spurious Emissions mode>

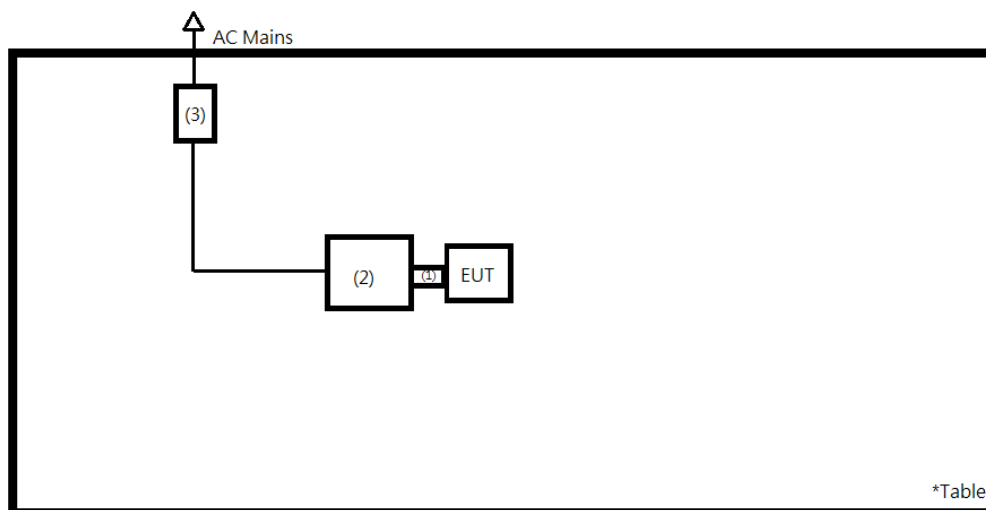

5. Test Results

5.1 Transmitter Requirement & Test Suites

5.1.1 Antenna Requirement

Requirement Use of approved antennas only

According to the manufacturer declaration, the EUT has an antenna with a directional gain of 1.6dBi dBi. The antenna is a printed PCB trace with no possibility of replacement with a non-approved antenna by the end-user. Therefore, the EUT is considered to comply with this provision.
Refer to EUT photo for details.

5.1.2 Peak Output Power

Limit 1 watt (30 dBm)

Kind of Test Site Shielded room

Test Setup



Test Instruments

Kind of Equipment	Manufacturer	Type	S/N	Calibration Date	Calibration Due Date	Test Date	
						From	Until
Power Meter	Anritsu	ML2495A	1901008	2020/4/6	2021/4/5	2020/11/13	2020/11/13
Power Sensor	Anritsu	MA2411B	1725269	2020/4/7	2021/4/6		

Test Procedures

A peak power sensor was used on the output port of the EUT. A power meter was used to read the response of the peak power sensor. Record the power level.

Average power sensor was used to perform output power measurement, trigger and gating function of wide band power meter is enabled to measure max output power of TX on burst. Duty factor is not added to measured value.

Test Result
Peak Output Power
<1Mbps>

Channel	Channel Frequency	Peak Output Power		Limit (dBm)
	(MHz)	(dBm)	(mW)	
Low Channel	2402	6.87	4.86	30
Middle Channel	2440	5.55	3.59	30
High Channel	2480	5.84	3.84	30

<2Mbps>

Channel	Channel Frequency	Peak Output Power		Limit (dBm)
	(MHz)	(dBm)	(mW)	
Low Channel	2402	6.85	4.84	30
Middle Channel	2440	5.88	3.87	30
High Channel	2480	5.49	3.54	30

Average Power
<1Mbps>

Channel	Channel Frequency	Average Power	
	(MHz)	(dBm)	(mW)
Low Channel	2402	6.85	4.84
Middle Channel	2440	5.42	3.48
High Channel	2480	5.72	3.73

<2Mbps>

Channel	Channel Frequency	Average Power	
	(MHz)	(dBm)	(mW)
Low Channel	2402	6.83	4.82
Middle Channel	2440	5.77	3.78
High Channel	2480	5.38	3.45

5.1.3 6 dB Bandwidth

Limit The minimum 6 dB bandwidth shall be at least 500 kHz.

Kind of Test Site Shielded room

Test Setup

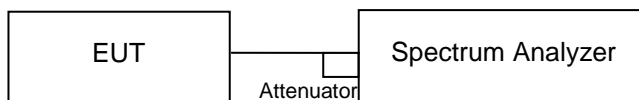

Test Instruments

Kind of Equipment	Manufacturer	Type	S/N	Calibration Date	Calibration Due Date	Test Date	
						From	Until
Spectrum Analyzer	Agilent	N9010A	MY53470241	2020/6/2	2021/6/1	2020/11/10	2020/11/13

Test Procedure

- Set resolution bandwidth (RBW) = 100 kHz
- Set the video bandwidth (VBW) $\geq 3 \times$ RBW, Detector = Peak.
- Trace mode = max hold.
- Sweep = auto couple.
- Measure the maximum width of the emission that is constrained by the frequencies associated with the two amplitude points (upper and lower) that are attenuated by 6 dB relative to the maximum level measured in the fundamental emission.

Test Results

Please refer to Appendix A.

5.1.4 Power Spectral Density

Limit

The power spectral density shall not be greater than 8 dBm in any 3 kHz band.

Kind of Test Site Shielded room

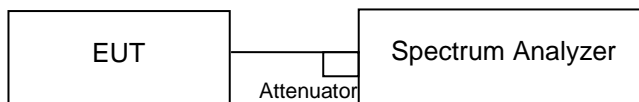
Test Setup

Test Instruments

Kind of Equipment	Manufacturer	Type	S/N	Calibration Date	Calibration Due Date	Test Date	
						From	Until
Spectrum Analyzer	Agilent	N9010A	MY53470241	2020/6/2	2021/6/1	2020/11/10	2020/11/13

Test Procedure

- a. Set analyzer center frequency to DTS channel center frequency.
- b. Set the span to 1.5 times the DTS bandwidth.
- c. Set the RBW to: $3 \text{ kHz} \leq \text{RBW} \leq 100 \text{ kHz}$.
- d. Set the VBW $\geq 3 \times \text{RBW}$.
- e. Detector = peak.
- f. Sweep time = auto couple.
- g. Trace mode = max hold.
- h. Allow trace to fully stabilize.
- i. Use the peak marker function to determine the maximum amplitude level within the RBW.

Test Results

Please refer to Appendix A.

5.1.5 Conducted Spurious Emissions and Frequency Band Edges Measured in 100kHz Bandwidth

Limit

20dB (below that in the 100 kHz bandwidth within the band that contains the highest level of the desired power.)

Kind of Test Site Shielded room

Test Setup

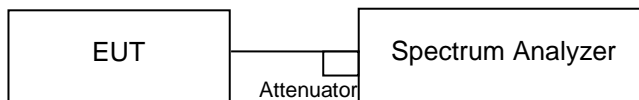

Test Instruments

Kind of Equipment	Manufacturer	Type	S/N	Calibration Date	Calibration Due Date	Test Date	
						From	Until
Spectrum Analyzer	Agilent	N9010A	MY53470241	2020/6/2	2021/6/1	2020/11/10	2020/11/13

Test Procedure

Measurement procedure REF

1. Set the RBW = 100 kHz.
2. Set the VBW \geq 300 kHz.
3. Detector = peak.
4. Sweep time = auto couple.
5. Trace mode = max hold.
6. Allow trace to fully stabilize.
7. Use the peak marker function to determine the maximum power level in any 100 kHz band segment within the fundamental EBW.

Measurement procedure OOBE

1. Set RBW = 100 kHz.
2. Set VBW \geq 300 kHz.
3. Detector = peak.
4. Sweep = auto couple.
5. Trace Mode = max hold.
6. Allow trace to fully stabilize.
7. Use the peak marker function to determine the maximum amplitude level.

Test Results

Please refer to Appendix A.

5.1.6 Radiated Spurious Emissions and Band Edges

Limit

Radiated emissions which fall in the restricted bands, as defined in §15.205(a), must comply with the radiated emission limits specified in §15.209(a).

Emissions radiated outside the restricted and authorized frequency bands must either comply with the radiated emission limits specified for the restricted bands or in §15.247(d).

Kind of Test Site 3m Semi-Anechoic Chamber

Test Setup

<Radiated Emissions below 30 MHz>

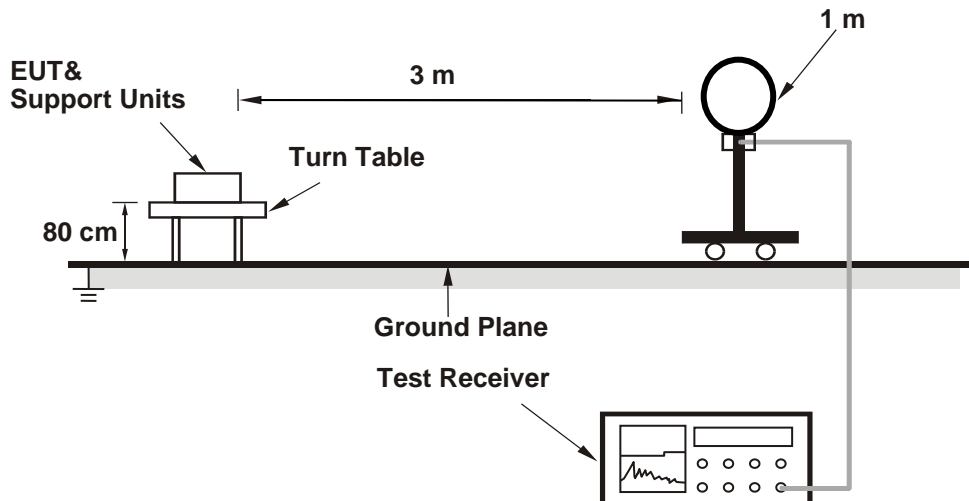

<Radiated Emissions 30 MHz to 1 GHz>

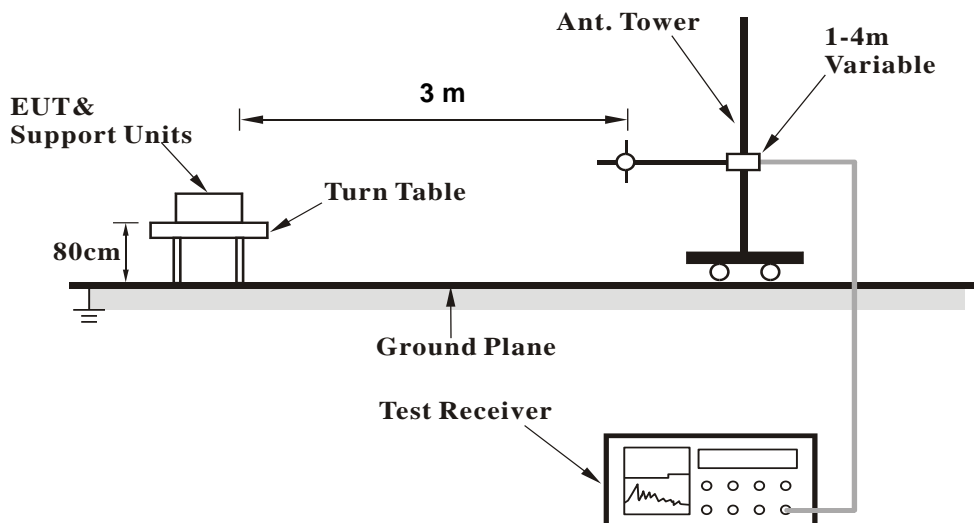

<Radiated Emissions above 1 GHz>

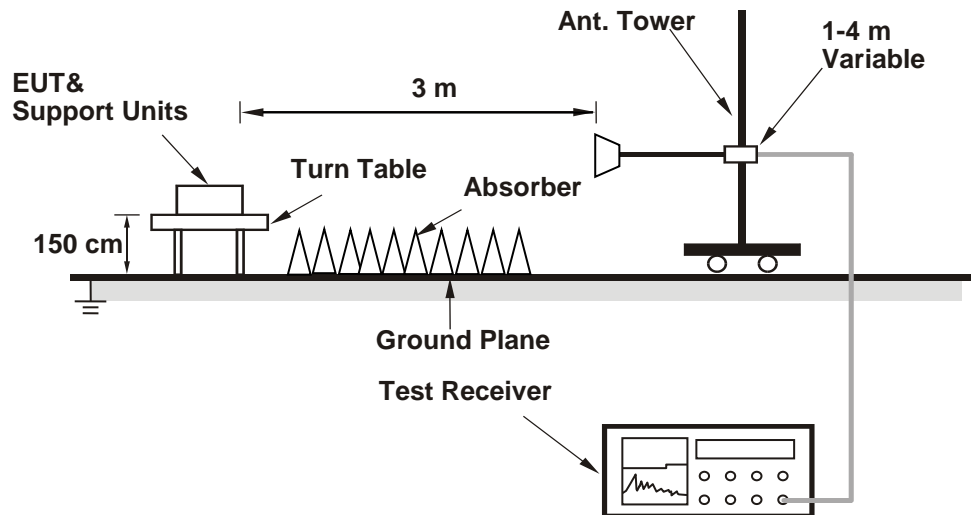

For the actual test configuration, please refer to the attached file (Test Setup Photo).

Test Instruments

Kind of Equipment	Manufacturer	Type	S/N	Calibration Date	Calibration Due Date
Signal Analyzer	R&S	FSV40	101508	2020/3/16	2021/3/15
Receiver	R&S	ESR7	102108	2020/4/22	2021/4/21
Bilog Antenna	SCHWARZBECK	VULB-9168	00951	2020/2/14	2021/2/12
Horn Antenna	ETS-Lindgren	3117	00218930	2019/12/6	2020/12/4
LF-AMP	Agilent	8447D	2944A10772	2020/2/11	2021/2/9
HF-AMP + AC source	EMCI	EMC051845SE	980633	2020/2/17	2021/2/15
HF-AMP + AC source	EMCI	EMC184045SE	980657	2020/2/17	2021/2/15
Horn Antenna	SCHWARZBECK	BBHA 9170	00887	2020/4/10	2021/4/9
Microwave Cable	HUBER+SUHNER	SUCOFLEX 104EA	800056/4EA	2020/3/25	2021/3/24
Microwave Cable	HUBER+SUHNER	SUCOFLEX 104	804680/4	2020/3/25	2021/3/24
Microwave Cable	HUBER+SUHNER	SUCOFLEX 104	MY37202/4	2020/3/25	2021/3/24
Microwave Cable	HUBER+SUHNER	SUCOFLEX 102EA	800898/2EA	2020/4/22	2021/4/21
Microwave Cable	HUBER+SUHNER	SUCOFLEX 102EA	800901/2EA	2020/4/22	2021/4/21
Microwave Cable	HUBER+SUHNER	SUCOFLEX 102EA	801027/2EA	2020/4/22	2021/4/21
Loop Antenna	Chance Most	EMCILPA600 +calibration	287	2020/1/9	2021/1/7

Test Procedures**For Radiated Emissions below 30 MHz**

- a. The EUT was placed on the top of a rotating table 0.8 meters above the ground at a 3 meter chamber room. The table was rotated 360 degrees to determine the position of the highest radiation.
- b. The EUT was set 3 meters away from the interference-receiving antenna, which was mounted on the top of a variable-height antenna tower.
- c. Parallel (OPEN), perpendicular (CLOSE), and ground-parallel (GROUND) orientations of the antenna are set to make the measurement.
- d. For each suspected emission, the EUT was arranged to its worst case and the rotatable table was turned from 0 degrees to 360 degrees to find the maximum reading.
- e. The test-receiver system was set to Quasi-Peak Detect Function and Specified Bandwidth with Maximum Hold Mode.

Note:

1. The resolution bandwidth and video bandwidth of test receiver/spectrum analyzer is 9 kHz at frequency below 30 MHz.
2. All modes of operation were investigated and the worst-case emissions are reported.

For Radiated Emissions above 30 MHz

- a. The EUT was placed on the top of a rotating table 0.8 meters (for 30 MHz ~ 1 GHz) / 1.5 meters (for above 1 GHz) above the ground at 3 meter chamber room for test. The table was rotated 360 degrees to determine the position of the highest radiation.
- b. The EUT was set 3 meters away from the interference-receiving antenna, which was mounted on the top of a variable-height antenna tower.
- c. The height of antenna is varied from one meter to four meters above the ground to determine the maximum value of the field strength. Both horizontal and vertical polarizations of the antenna are set to make the measurement.
- d. For each suspected emission, the EUT was arranged to its worst case and then the antenna was tuned to heights from 1 meter to 4 meters and the rotatable table was turned from 0 degrees to 360 degrees to find the maximum reading.
- e. The test-receiver system was set to quasi-peak detect function and specified bandwidth with maximum hold mode when the test frequency is below 1 GHz.
- f. The test-receiver system was set to peak and average detected function and specified bandwidth with maximum hold mode when the test frequency is above 1 GHz. If the peak reading value also meets average limit, measurement with the average detector is unnecessary.

Note:

1. The resolution bandwidth and video bandwidth of test receiver/spectrum analyzer is 120 kHz for Quasi-peak detection (QP) or Peak detection (PK) at frequency below 1 GHz.
2. The resolution bandwidth of test receiver/spectrum analyzer is 1 MHz and the video bandwidth is 3 MHz for Peak detection (PK) at frequency above 1 GHz.
3. The resolution bandwidth of test receiver/spectrum analyzer is 1 MHz and the video bandwidth is $\geq 1/T$ (Duty cycle < 98 %) or 10 Hz (Duty cycle ≥ 98 %) for Average detection (AV) at frequency above 1 GHz.
4. All modes of operation were investigated and the worst-case emissions are reported.
5. The Radiated Emissions testing was performed in the X, Y and Z axis orientation. The worst-case Axis orientation is recorded in this test report.

Prüfbericht - Nr.: **CN20H36H(P15C-BLE) 001**
Test Report No.

Seite 24 von 24
Page 24 of 24

Test Results

Factor (dB/m) = Antenna Factor (dB/m) + Cable Loss (dB)
Level (dBuV/m) = Reading (dBuV) + Factor (dB/m)

Please refer to Appendix B.

Appendix A: Test Results of Conducted Test

Test Result of 6 dB Bandwidth

BLE_1M

Channel	Channel Frequency (MHz)	6 dB Bandwidth (kHz)	Limit (kHz)	Result
Low Channel	2402	710.29	> 500	Pass
Middle Channel	2440	710.29	> 500	Pass
High Channel	2480	707.29	> 500	Pass

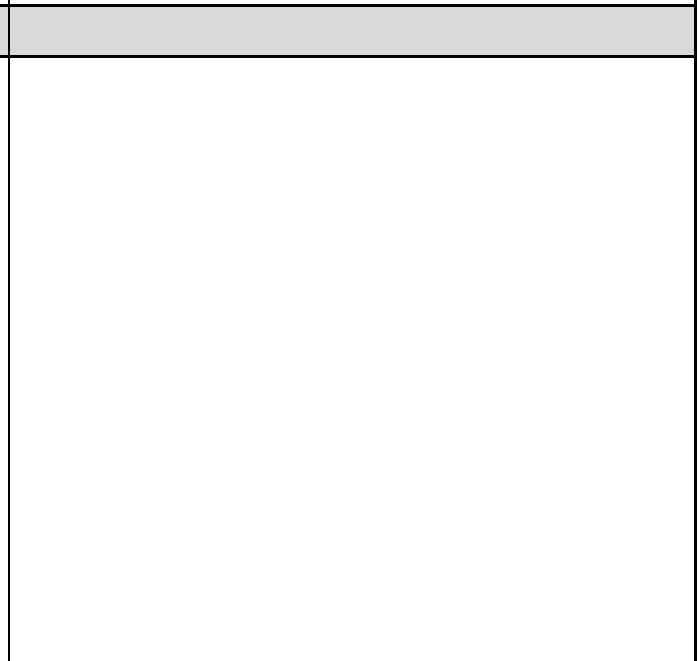
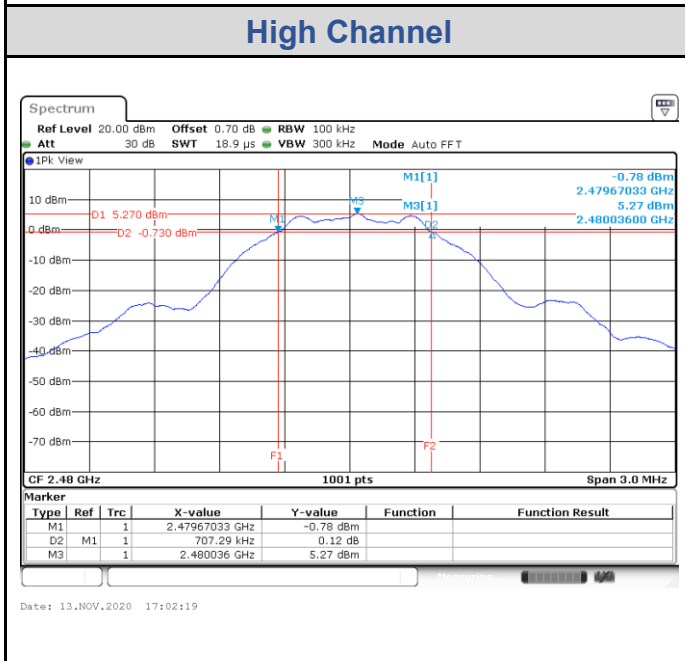
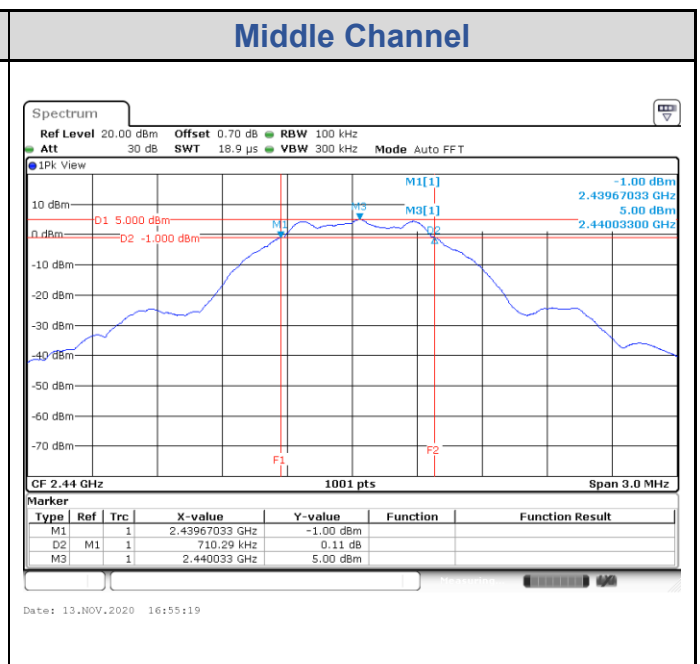
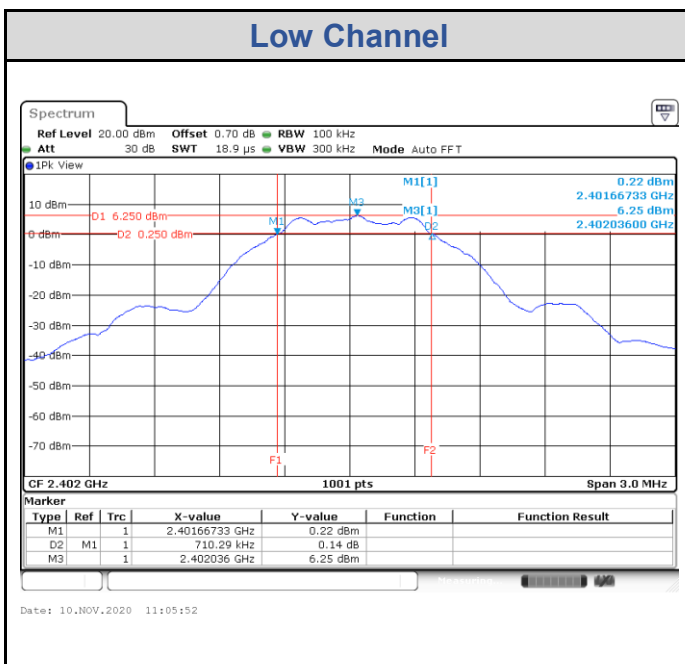

BLE_2M

Channel	Channel Frequency (MHz)	6 dB Bandwidth (kHz)	Limit (kHz)	Result
Low Channel	2402	1128.87	> 500	Pass
Middle Channel	2440	1128.87	> 500	Pass
High Channel	2480	1128.87	> 500	Pass

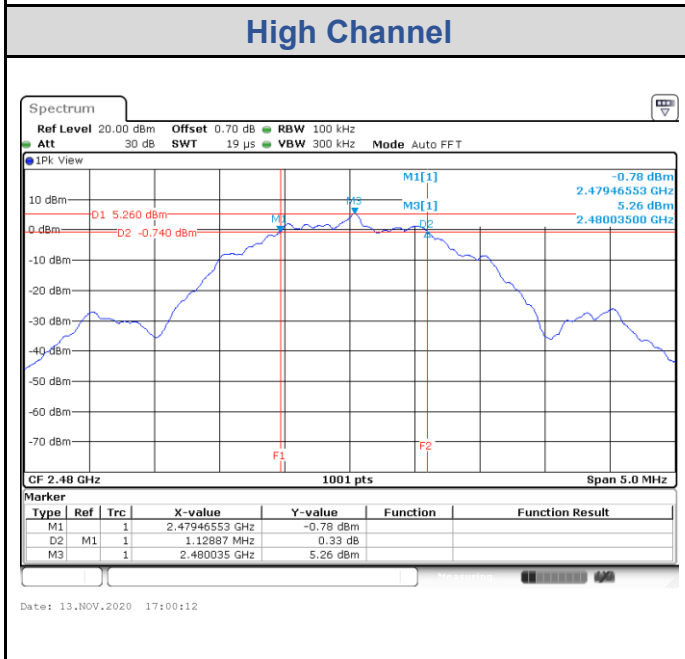
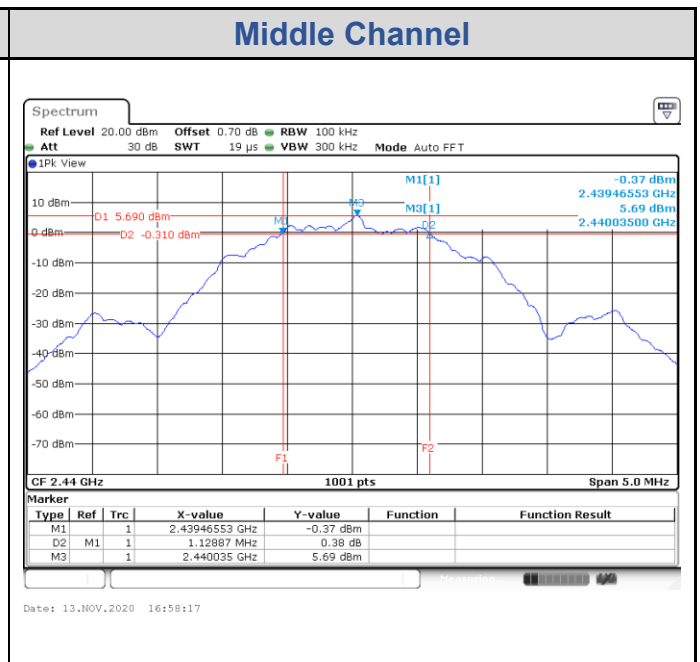
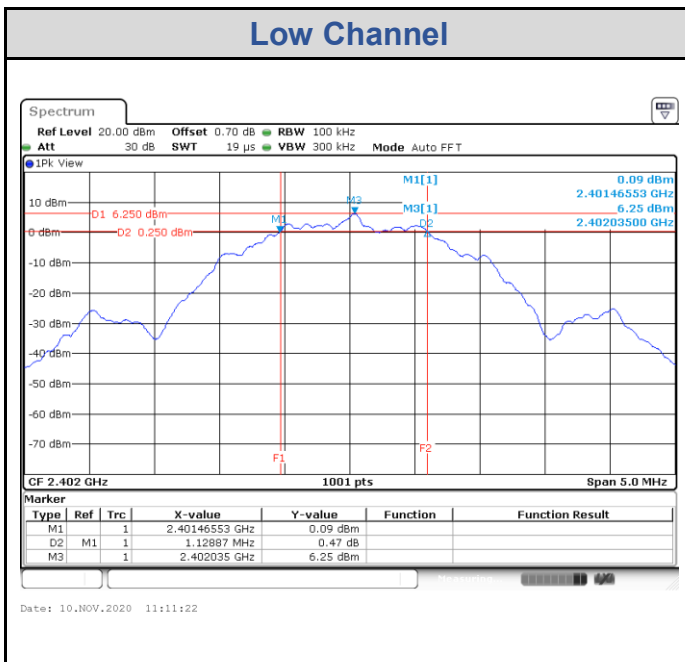

Test Result of Power Spectral Density

BLE_1M

Channel	Channel Frequency (MHz)	Power Density (dBm/3kHz)	Limit (dBm/3kHz)	Result
Low Channel	2402	-9.32	8	Pass
Middle Channel	2440	-10.48	8	Pass
High Channel	2480	-10.21	8	Pass

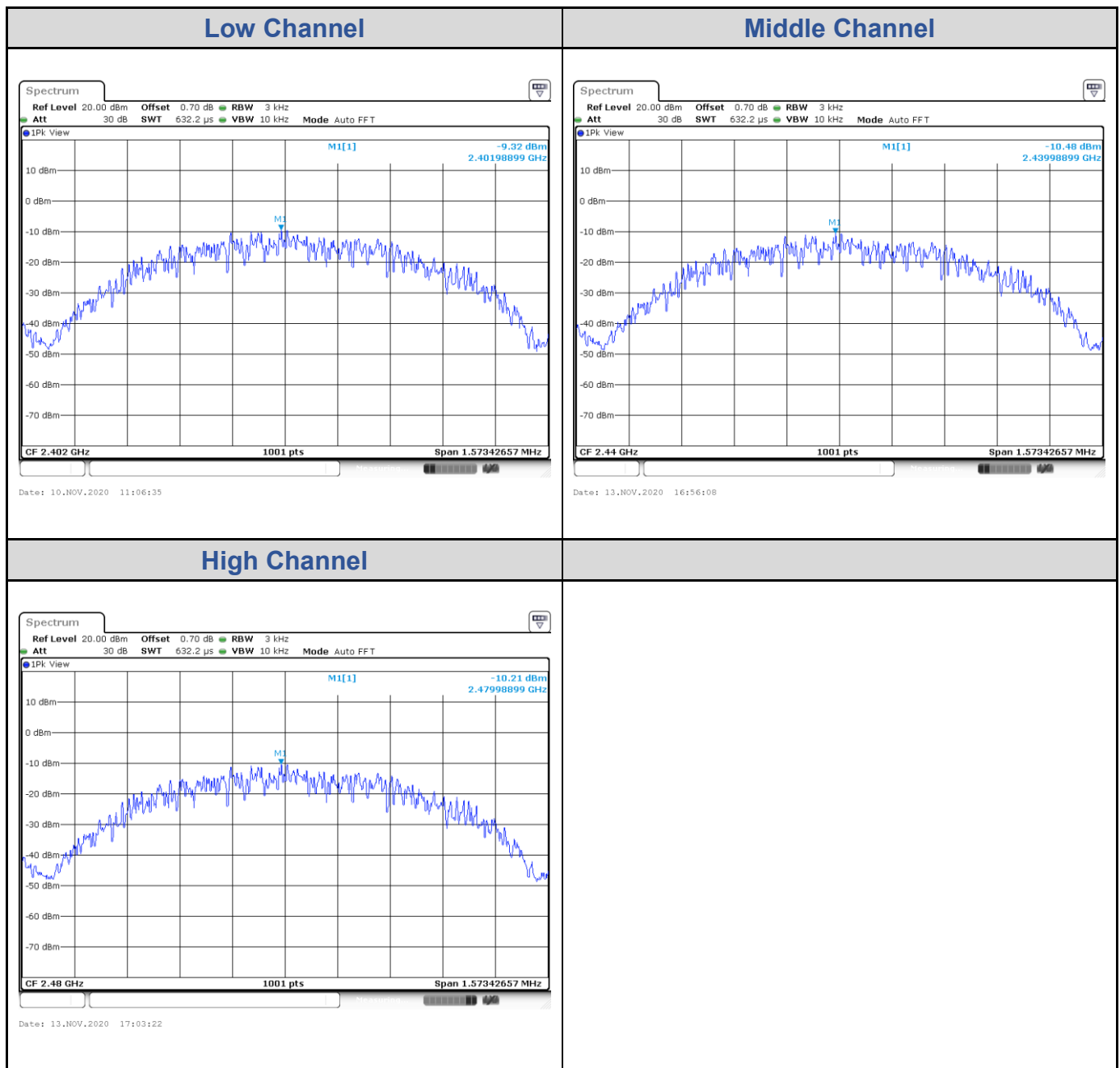

BLE_2M

Channel	Channel Frequency (MHz)	Power Density (dBm/3kHz)	Limit (dBm/3kHz)	Result
Low Channel	2402	-11.77	8	Pass
Middle Channel	2440	-12.19	8	Pass
High Channel	2480	-12.71	8	Pass

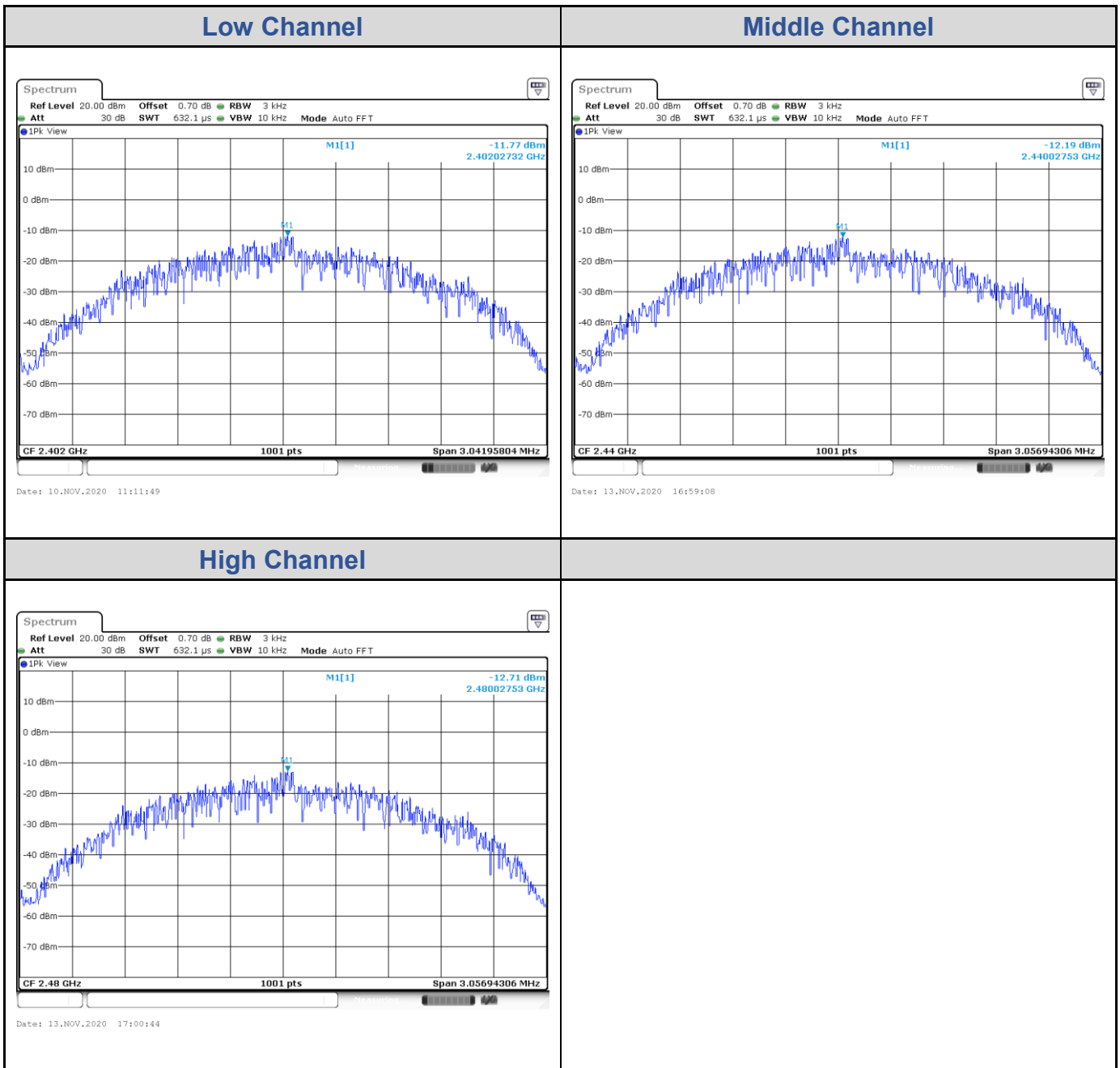

Test Result of Conducted Spurious Emissions, Tx Mode

BLE_1M

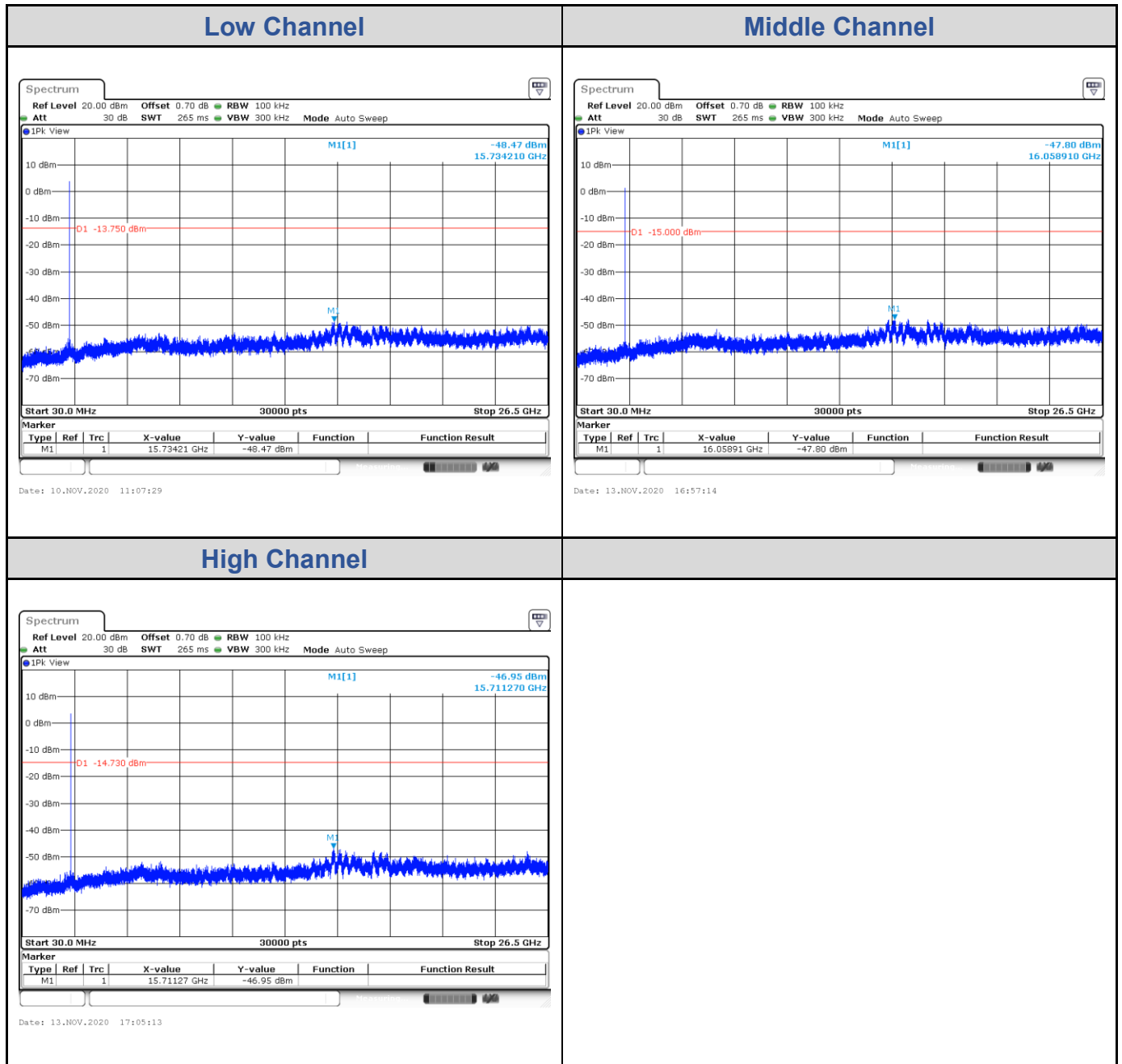

BLE_2M

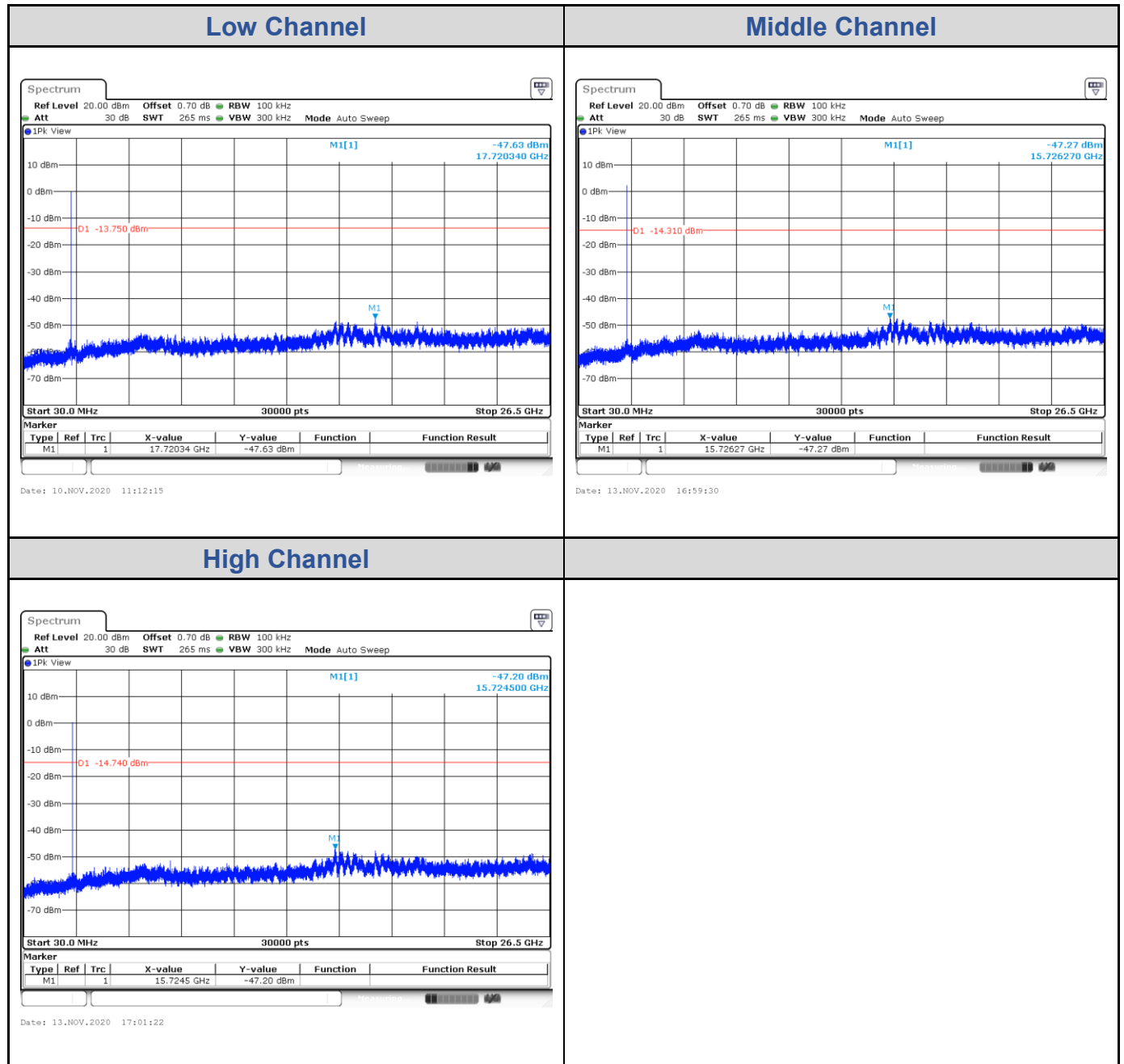

Test Result of Conducted Band Edge, Tx Mode
BLE_1M

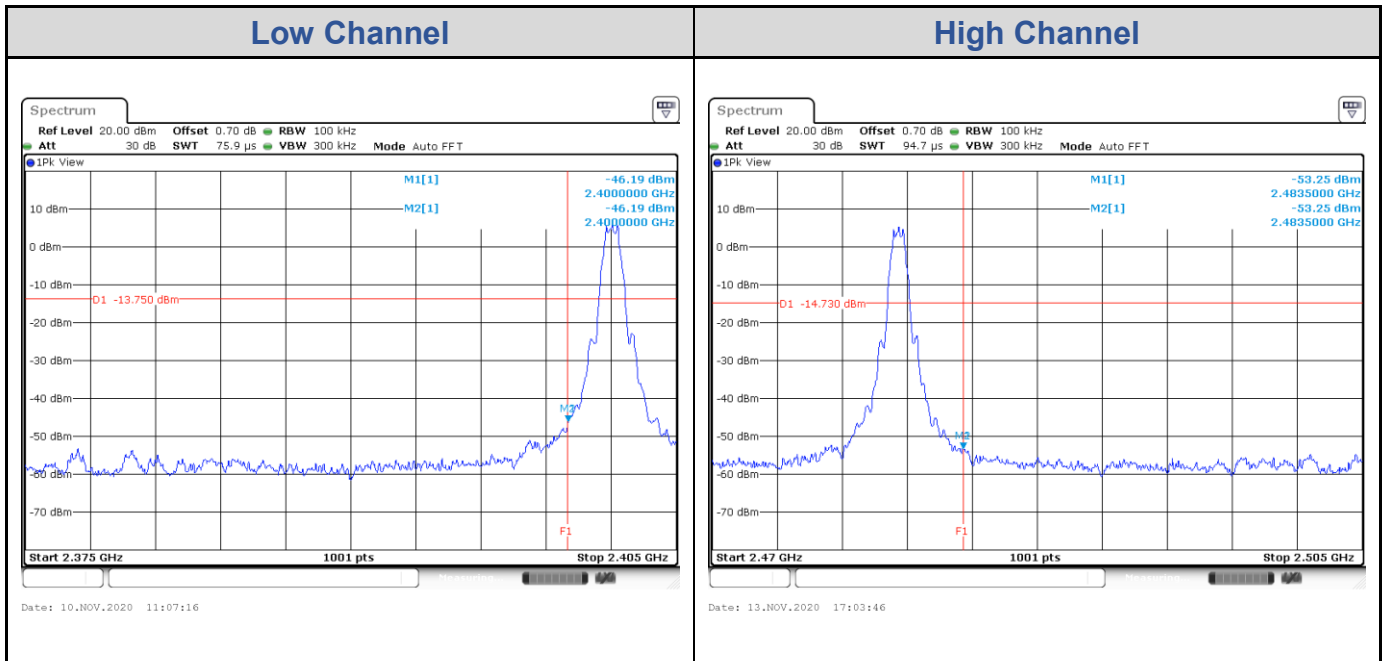

BLE_2M

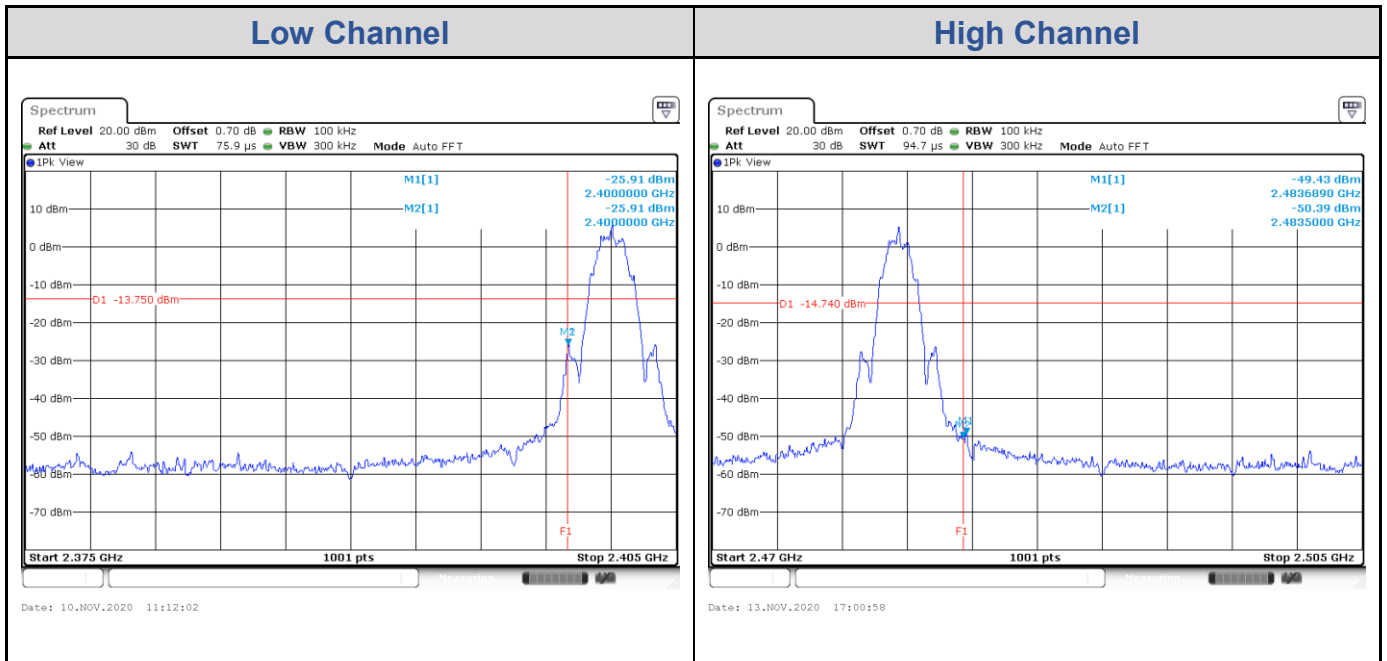

Appendix B: Test Results of Radiated Emissions

Band Edges, 2.31GHz ~ 2.9GHz

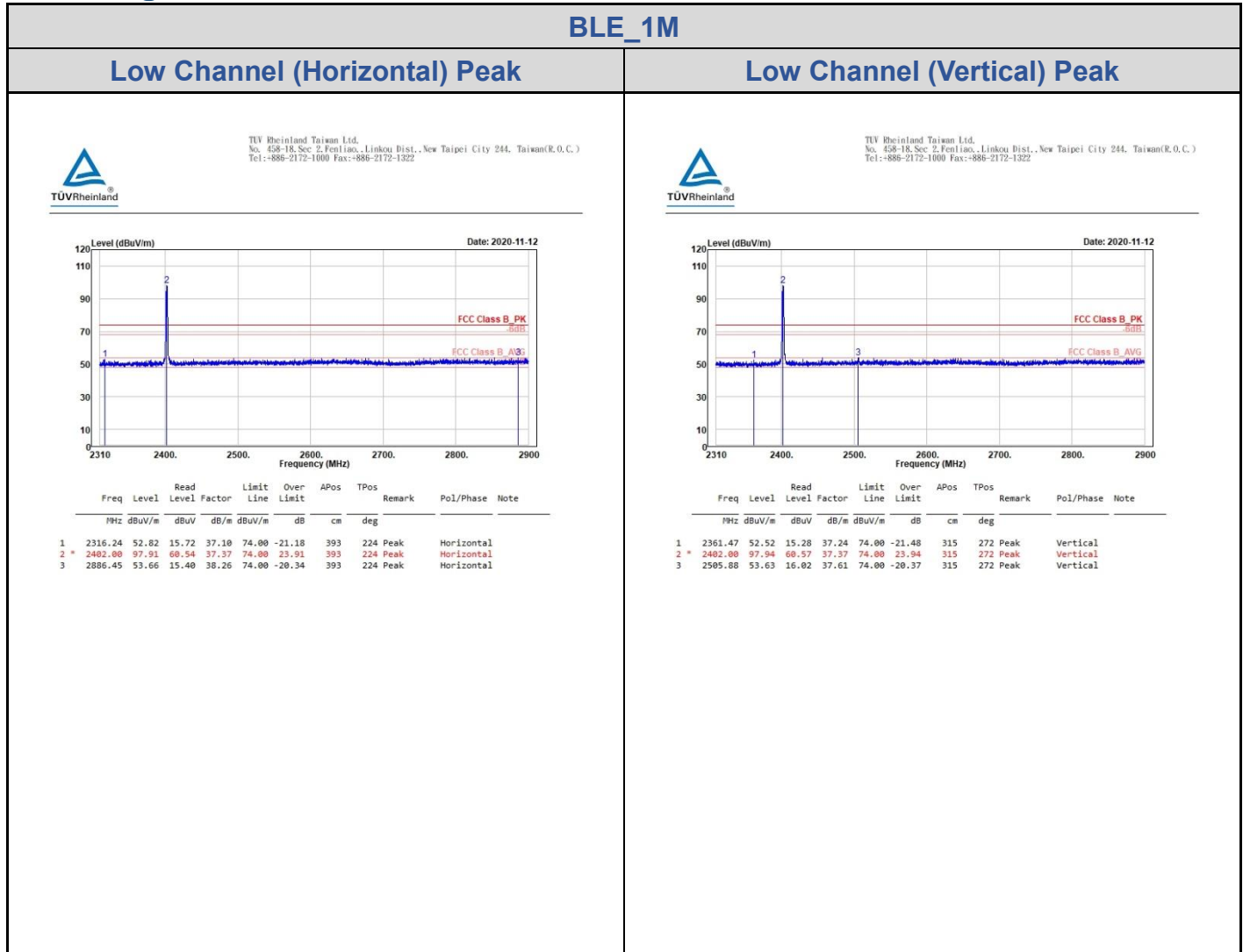

BLE_1M
Low Channel (Horizontal) Average
Low Channel (Vertical) Average

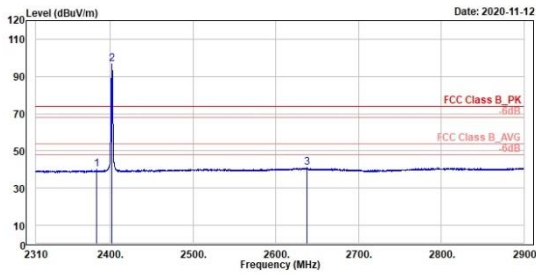

TÜV Rheinland Taiwan Ltd.
 No. 458-18, Sec. 2, Fenhiao, Linkou Dist., New Taipei City 244, Taiwan(R.O.C.)
 Tel: +886-2172-1000 Fax: +886-2172-1322



Freq	Level	Read Level	Factor	Limit Line	Over Limit	APos	TPos	Remark	Pol/Phase	Note
MHz	dBuV/m	dBuV	dB/m	dBuV/m	dB	cm	deg			
1	2383.58	39.99	2.68	37.31	54.00	-14.01	393	224 Average	Horizontal	
2 *	2482.00	96.84	59.47	37.37	54.00	42.84	393	224 Average	Horizontal	
3	2637.80	40.90	3.02	37.88	54.00	-13.10	393	224 Average	Horizontal	

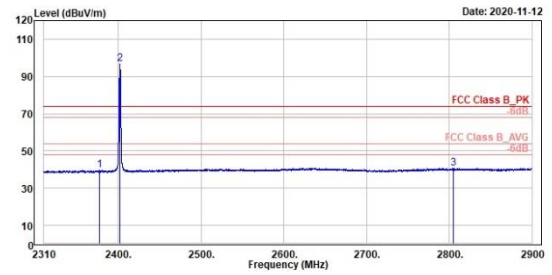

TÜV Rheinland Taiwan Ltd.
 No. 458-18, Sec. 2, Fenhiao, Linkou Dist., New Taipei City 244, Taiwan(R.O.C.)
 Tel: +886-2172-1000 Fax: +886-2172-1322



Freq	Level	Read Level	Factor	Limit Line	Over Limit	APos	TPos	Remark	Pol/Phase	Note
MHz	dBuV/m	dBuV	dB/m	dBuV/m	dB	cm	deg			
1	2377.49	39.72	2.43	37.29	54.00	-14.28	315	272 Average	Vertical	
2 *	2482.00	96.89	59.52	37.37	54.00	42.89	315	272 Average	Vertical	
3	2804.71	40.64	2.71	37.93	54.00	-13.36	315	272 Average	Vertical	

BLE_1M
High Channel (Horizontal) Peak
High Channel (Vertical) Peak

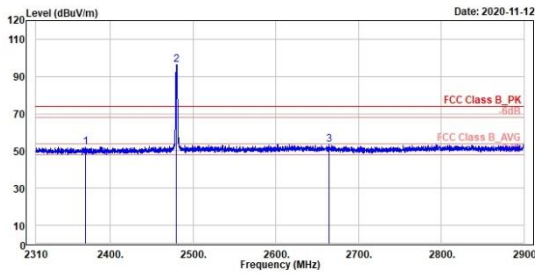

TÜV Rheinland Taiwan Ltd.
 No. 458-18, Sec. 2, Fenhiao, Linkou Dist., New Taipei City 244, Taiwan(R.O.C.)
 Tel:+886-2172-1000 Fax:+886-2172-1322



Peak	Freq	Level	Read Level	Factor	Limit Line	Over Limit	APos	TPos	Remark	Pol/Phase	Note
	MHz	dBuV/m	dBuV	dB/m	dBuV/m	dB	cm	deg			
1	2369.95	52.16	14.89	37.27	74.00	-21.84	306	353	Peak	Horizontal	
2 *	2480.00	96.43	58.87	37.56	74.00	22.43	306	353	Peak	Horizontal	
3	2665.01	53.48	15.65	37.83	74.00	-20.52	306	353	Peak	Horizontal	

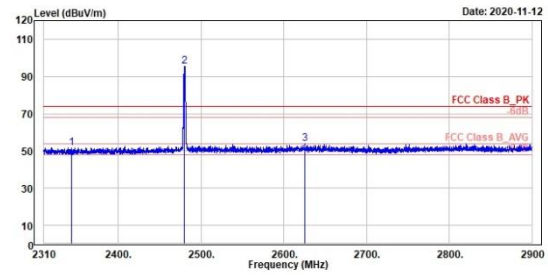

TÜV Rheinland Taiwan Ltd.
 No. 458-18, Sec. 2, Fenhiao, Linkou Dist., New Taipei City 244, Taiwan(R.O.C.)
 Tel:+886-2172-1000 Fax:+886-2172-1322



Peak	Freq	Level	Read Level	Factor	Limit Line	Over Limit	APos	TPos	Remark	Pol/Phase	Note
	MHz	dBuV/m	dBuV	dB/m	dBuV/m	dB	cm	deg			
1	2343.10	51.65	14.46	37.19	74.00	-22.35	332	263	Peak	Vertical	
2 *	2480.00	95.48	57.92	37.56	74.00	21.48	332	263	Peak	Vertical	
3	2625.44	53.72	15.80	37.92	74.00	-20.28	332	263	Peak	Vertical	

BLE_1M

High Channel (Horizontal) Average

High Channel (Vertical) Average



TÜV Rheinland Taiwan Ltd.
No. 458-18, Sec. 2, Fenhiao, Linkou Dist., New Taipei City 244, Taiwan(R.O.C.)
Tel: +886-2172-1000 Fax: +886-2172-1322

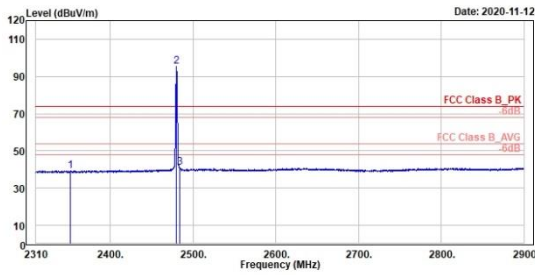

Read	Level	Factor	Limit	Over	APos	TPos	Remark	Pol/Phase	Note
MHz	dBuV/m	dBuV	dB/m	dBuV/m	dB	cm	deg		
1	2352.05	39.35	2.14	37.21	54.00	-14.65	306	353 Average	Horizontal
2 *	2480.00	95.37	57.81	37.56	54.00	41.37	306	353 average	Horizontal
3	2483.74	41.19	3.63	37.56	54.00	-12.81	306	353 Average	Horizontal



TÜV Rheinland Taiwan Ltd.
No. 458-18, Sec. 2, Fenhiao, Linkou Dist., New Taipei City 244, Taiwan(R.O.C.)
Tel: +886-2172-1000 Fax: +886-2172-1322

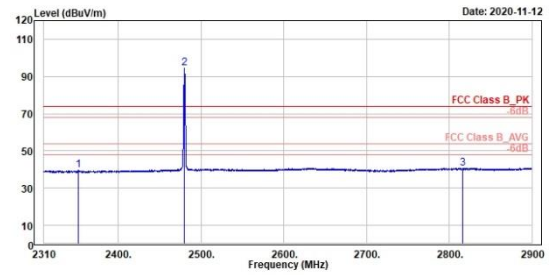

Read	Level	Factor	Limit	Over	APos	TPos	Remark	Pol/Phase	Note
MHz	dBuV/m	dBuV	dB/m	dBuV/m	dB	cm	deg		
1	2352.05	39.53	2.32	37.21	54.00	-14.47	332	263 Average	Vertical
2 *	2480.00	94.44	56.88	37.56	54.00	40.44	332	263 Average	Vertical
3	2816.49	40.70	2.74	37.96	54.00	-13.30	332	263 Average	Vertical

BLE_2M
Low Channel (Horizontal) Peak
Low Channel (Vertical) Peak

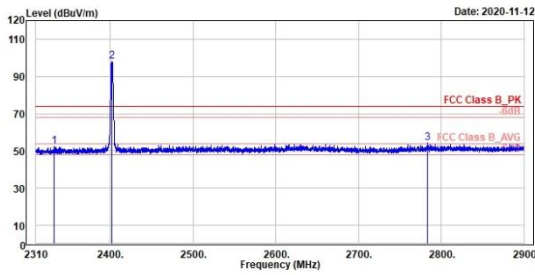

TUV Rheinland Taiwan Ltd.
 No. 458-18, Sec. 2, Fenhiao, Linkou Dist., New Taipei City 244, Taiwan(R.O.C.)
 Tel: +886-2172-1000 Fax: +886-2172-1322



Peak	Freq (MHz)	Level (dBuV/m)	Read Level (dBuV)	Level Factor (dB/m)	Limit Line (dBuV/m)	Over Limit (dB)	APos (cm)	TPos (deg)	Remark	Pol/Phase	Note
1	2331.67	52.35	15.21	37.14	74.00	-21.65	400	221	Peak	Horizontal	
2 *	2402.00	98.02	60.65	37.37	74.00	24.02	400	221	Peak	Horizontal	
3	2783.74	54.17	16.28	37.89	74.00	-19.83	400	221	Peak	Horizontal	

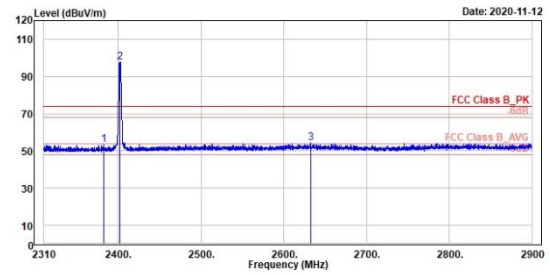

TUV Rheinland Taiwan Ltd.
 No. 458-18, Sec. 2, Fenhiao, Linkou Dist., New Taipei City 244, Taiwan(R.O.C.)
 Tel: +886-2172-1000 Fax: +886-2172-1322



Peak	Freq (MHz)	Level (dBuV/m)	Read Level (dBuV)	Level Factor (dB/m)	Limit Line (dBuV/m)	Over Limit (dB)	APos (cm)	TPos (deg)	Remark	Pol/Phase	Note
1	2381.97	53.20	15.90	37.30	74.00	-20.80	316	270	Peak	Vertical	
2 *	2402.00	97.04	60.47	37.37	74.00	23.04	316	270	Peak	Vertical	
3	2632.74	54.17	16.27	37.90	74.00	-19.83	316	270	Peak	Vertical	

BLE_2M
Low Channel (Horizontal) Average
Low Channel (Vertical) Average

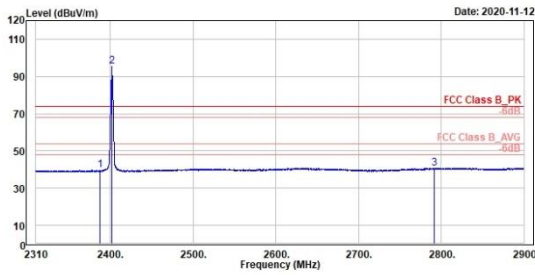

TÜV Rheinland Taiwan Ltd.
 No. 458-18, Sec. 2, Fenhiao, Linkou Dist., New Taipei City 244, Taiwan(R.O.C.)
 Tel: +886-2172-1000 Fax: +886-2172-1322



Freq	Level	Read	Level	Factor	Limit	Over	APos	TPos	Remark	Pol/Phase	Note
MHz	dBuV/m	dBuV	dB/m	dBuV/m	dB	cm	cm	deg			
1	2387.15	39.66	2.34	37.32	54.00	-14.34	400	221	Average	Horizontal	
2 *	2482.00	95.23	57.86	37.37	54.00	41.23	400	221	Average	Horizontal	
3	2791.99	40.81	2.91	37.90	54.00	-13.19	400	221	Average	Horizontal	

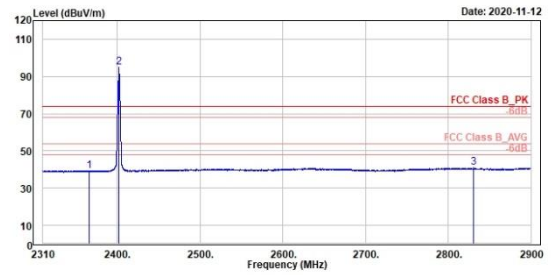

TÜV Rheinland Taiwan Ltd.
 No. 458-18, Sec. 2, Fenhiao, Linkou Dist., New Taipei City 244, Taiwan(R.O.C.)
 Tel: +886-2172-1000 Fax: +886-2172-1322

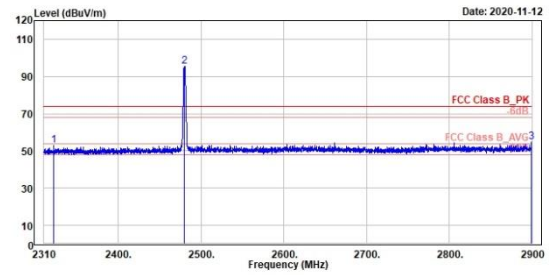
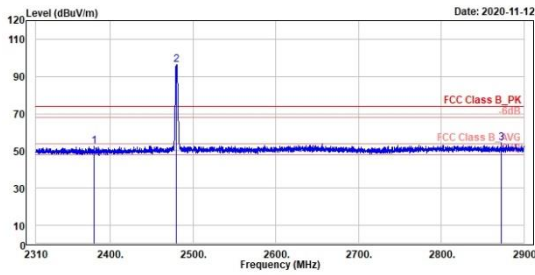

Freq	Level	Read	Level	Factor	Limit	Over	APos	TPos	Remark	Pol/Phase	Note
MHz	dBuV/m	dBuV	dB/m	dBuV/m	dB	cm	cm	deg			
1	2366.42	39.46	2.20	37.26	54.00	-14.54	316	270	Average	Vertical	
2 *	2482.00	94.88	57.51	37.37	54.00	40.88	316	270	Average	Vertical	
3	2831.09	40.85	2.85	38.00	54.00	-13.15	316	270	Average	Vertical	

BLE_2M
High Channel (Horizontal) Peak
High Channel (Vertical) Peak

Freq	Level	Read	Level	Factor	Limit	Over	APos	TPos	Remark	Pol/Phase	Note
MHz	dBuV/m	dBuV	dB/m	dB/m	dBuV/m	dB	cm	deg			
1	2380.20	52.52	15.22	37.30	74.00	-21.48	306	353	Peak	Horizontal	
2 *	2480.00	96.45	58.89	37.56	74.00	22.45	306	353	Peak	Horizontal	
3	2872.67	54.22	16.04	38.18	74.00	-19.78	306	353	Peak	Horizontal	

Freq	Level	Read	Level	Factor	Limit	Over	APos	TPos	Remark	Pol/Phase	Note
MHz	dBuV/m	dBuV	dB/m	dB/m	dBuV/m	dB	cm	deg			
1	2321.54	52.81	15.70	37.11	74.00	-21.19	332	263	Peak	Vertical	
2 *	2480.00	95.52	57.96	37.56	74.00	21.52	332	263	Peak	Vertical	
3	2899.76	54.60	16.28	38.32	74.00	-19.40	332	263	Peak	Vertical	

BLE_2M
High Channel (Horizontal) Average
High Channel (Vertical) Average

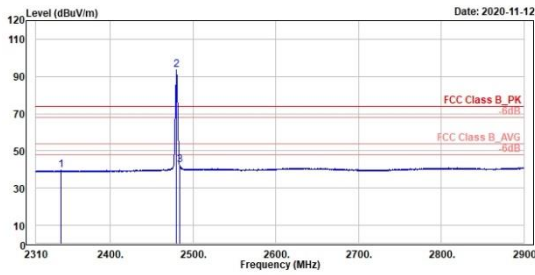

TÜV Rheinland Taiwan Ltd.
 No. 458-18, Sec. 2, Fenhiao, Linkou Dist., New Taipei City 244, Taiwan(R.O.C.)
 Tel: +886-2172-1000 Fax: +886-2172-1322



1	2	3	Read Level	Level Factor	Limit Line	Over Limit	APos	TPos	Remark	Pol/Phase	Note
MHz	dBuV/m	dBuV	dB/m	dBuV/m	dB	cm	deg				
2348.04	39.56	2.39	37.17	54.00	-14.44	306	353	Average	Horizontal		
2480.00	93.37	55.81	37.56	54.00	39.37	306	353	average	Horizontal		
2483.50	42.34	4.78	37.56	54.00	-11.66	306	353	Average	Horizontal		

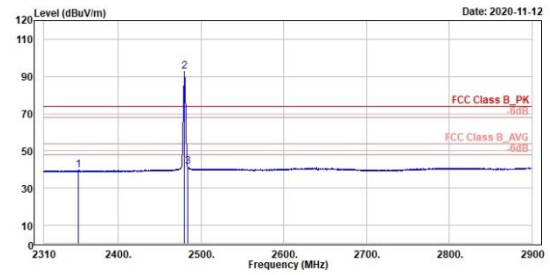

TÜV Rheinland Taiwan Ltd.
 No. 458-18, Sec. 2, Fenhiao, Linkou Dist., New Taipei City 244, Taiwan(R.O.C.)
 Tel: +886-2172-1000 Fax: +886-2172-1322



1	2	3	Read Level	Level Factor	Limit Line	Over Limit	APos	TPos	Remark	Pol/Phase	Note
MHz	dBuV/m	dBuV	dB/m	dBuV/m	dB	cm	deg				
2351.50	39.54	2.33	37.21	54.00	-14.46	332	263	Average	Vertical		
2480.00	92.72	55.16	37.56	54.00	38.72	332	263	Average	Vertical		
2483.50	41.56	4.00	37.56	54.00	-12.44	332	263	Average	Vertical		

Spurious Emissions, Tx Mode, 9kHz ~ 30MHz

BLE_2M

Middle Channel (Open) 9kHz~150kHz

Middle Channel (Open) 150kHz~30MHz



TUV Rheinland Taiwan Ltd.
No. 458-18, Sec. 2, Fenhiao, Linkou Dist., New Taipei City 244, Taiwan(R.O.C.)
Tel: +886-2172-1000 Fax: +886-2172-1322

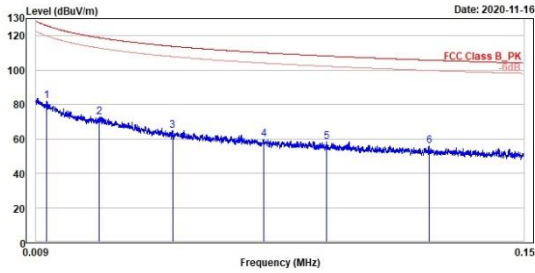

Freq	Level	Read	Level	Factor	Limit	Over	Apos	TPos	Remark	Pol/Phase	Note
MHz	dBuV/m	dBuV	dB/m	dBuV/m	dB	cm	deg				
1	0.01	82.12	4.60	77.52	125.93	-43.81	100	266	QP	Open	
2	0.03	72.82	1.60	71.22	118.86	-46.04	100	19	QP	Open	
3	0.05	64.63	-0.80	65.43	113.88	-49.25	100	348	QP	Open	
4	0.07	59.74	-2.08	61.82	110.12	-50.38	100	250	QP	Open	
5	0.09	58.45	-1.64	60.09	108.23	-49.78	100	275	QP	Open	
6	0.12	55.73	-2.21	57.94	105.83	-50.10	100	214	QP	Open	



TUV Rheinland Taiwan Ltd.
No. 458-18, Sec. 2, Fenhiao, Linkou Dist., New Taipei City 244, Taiwan(R.O.C.)
Tel: +886-2172-1000 Fax: +886-2172-1322

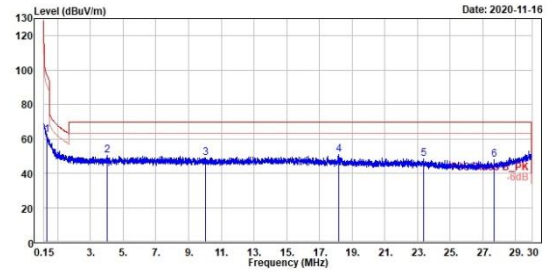

Freq	Level	Read	Level	Factor	Limit	Over	Apos	TPos	Remark	Pol/Phase	Note
MHz	dBuV/m	dBuV	dB/m	dBuV/m	dB	cm	deg				
1	0.34	62.46	12.74	49.72	97.10	-34.64	100	262	QP	Open	
2	4.03	50.58	12.25	38.33	69.50	-18.92	100	3	QP	Open	
3	10.02	49.15	11.57	37.58	69.50	-20.35	100	0	QP	Open	
4	18.17	50.71	13.93	36.78	69.50	-18.79	100	337	QP	Open	
5	23.38	48.33	13.01	35.32	69.50	-21.17	100	344	QP	Open	
6	27.71	47.74	12.86	34.88	69.50	-21.76	100	149	QP	Open	

BLE_2M

Middle Channel (Close) 9kHz~150kHz

Middle Channel (Close) 150kHz~30MHz



TUV Rheinland Taiwan Ltd.
No. 458-18, Sec. 2, Fenhiao, Linkou Dist., New Taipei City 244, Taiwan(R.O.C.)
Tel: +886-2172-1000 Fax: +886-2172-1322

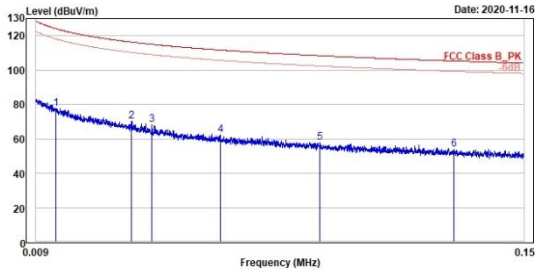

Freq	Level	Read	Limit	Over	APos	TPos	Remark	Pol/Phase	Note
MHz	dBuV/m	dBuV	dB/m	dBuV/m	dB	cm	deg		
1	0.01	77.78	1.99	75.79	124.16	-46.38	100	342 QP	Close
2	0.04	70.01	1.41	68.60	116.39	-46.29	100	260 QP	Close
3	0.04	68.15	1.23	66.92	115.02	-46.87	100	246 QP	Close
4	0.06	62.16	-1.20	63.36	111.71	-49.55	100	318 QP	Close
5	0.09	57.86	-2.46	60.32	108.41	-50.55	100	307 QP	Close
6	0.13	54.01	-3.52	57.53	105.34	-51.33	100	70 QP	Close



TUV Rheinland Taiwan Ltd.
No. 458-18, Sec. 2, Fenhiao, Linkou Dist., New Taipei City 244, Taiwan(R.O.C.)
Tel: +886-2172-1000 Fax: +886-2172-1322

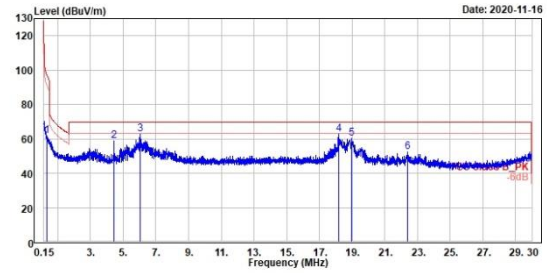

Freq	Level	Read	Limit	Over	APos	TPos	Remark	Pol/Phase	Note
MHz	dBuV/m	dBuV	dB/m	dBuV/m	dB	cm	deg		
1	0.34	61.85	12.31	49.54	96.87	-35.02	100	360 QP	Close
2	4.43	58.62	29.29	38.33	69.50	-10.88	100	25 QP	Close
3	6.05	62.67	24.52	38.35	69.50	-6.63	100	198 QP	Close
4	18.19	62.62	25.85	36.77	69.50	-6.88	100	89 QP	Close
5	18.98	60.08	23.62	36.46	69.50	-9.42	100	250 QP	Close
6	22.30	52.56	16.00	35.76	69.50	-16.94	100	185 QP	Close

Spurious Emissions, Tx Mode, 30MHz ~ 1GHz
BLE_2M
Middle Channel (Horizontal)
Middle Channel (Vertical)

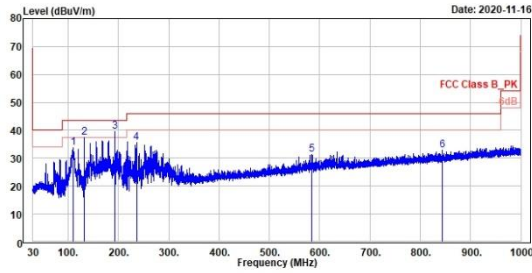

TÜV Rheinland Taiwan Ltd.
 No. 458-18, Sec. 2, Fenliao, Linkou Dist., New Taipei City 244, Taiwan(R.O.C.)
 Tel: +886-2172-1000 Fax: +886-2172-1322



Freq	Level	Read	Limit	Over	APos	TPos	Remark	Pol/Phase	Note
MHz	dBuV/m	dBuV	dB/m	dBuV/m	dB	cm	deg		
1	110.22	33.05	44.93	-11.08	43.50	-9.65	300	100 QP	Horizontal
2	132.24	37.34	46.16	-8.82	43.50	-6.16	100	193 QP	Horizontal
3	192.28	39.65	49.48	-9.83	43.50	-3.85	200	358 QP	Horizontal
4	235.83	35.50	43.99	-8.49	46.00	-10.50	100	159 QP	Horizontal
5	583.97	31.30	33.00	-1.70	46.00	-14.70	300	207 QP	Horizontal
6	843.93	32.93	30.59	2.34	46.00	-13.07	400	129 QP	Horizontal

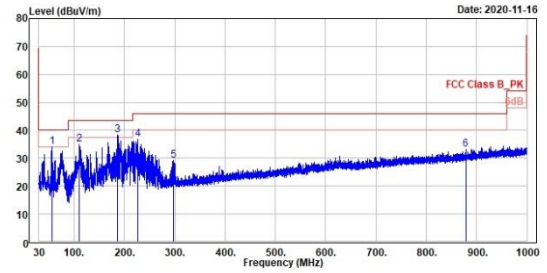

TÜV Rheinland Taiwan Ltd.
 No. 458-18, Sec. 2, Fenliao, Linkou Dist., New Taipei City 244, Taiwan(R.O.C.)
 Tel: +886-2172-1000 Fax: +886-2172-1322



Freq	Level	Read	Limit	Over	APos	TPos	Remark	Pol/Phase	Note
MHz	dBuV/m	dBuV	dB/m	dBuV/m	dB	cm	deg		
1	55.90	33.98	41.72	-7.74	40.00	-6.02	100	243 QP	Vertical
2	110.90	34.83	45.83	-11.00	43.50	-8.67	104	360 QP	Vertical
3	185.78	38.40	47.68	-9.28	43.50	-5.10	104	360 QP	Vertical
4	226.33	36.78	46.07	-9.29	46.00	-9.22	100	243 QP	Vertical
5	297.62	29.19	35.69	-6.50	46.00	-16.81	200	0 QP	Vertical
6	878.56	33.05	30.23	2.82	46.00	-12.95	147	360 QP	Vertical

Spurious Emissions, Tx Mode, 1GHz ~ 26.5GHz
BLE_1M
Low Channel (Horizontal)
Low Channel (Vertical)

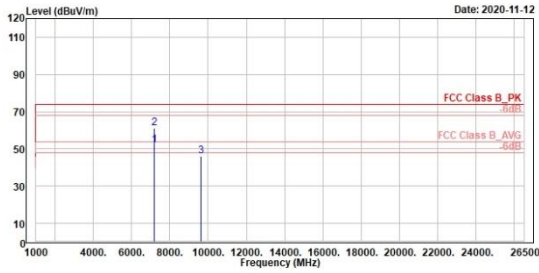

TÜV Rheinland Taiwan Ltd.
 No. 458-18, Sec. 2, Fenhiao, Linkou Dist., New Taipei City 244, Taiwan(R.O.C.)
 Tel: +886-2172-1000 Fax: +886-2172-1322



1	2	3
7286.00	7286.00	9608.00
51.96	61.15	46.24
59.61	68.80	51.53
-7.65	-7.65	-5.29
76.84	74.00	74.00
-24.88	-12.85	-27.76
378	378	100
256	256	127
Average	Peak	Peak
Horizontal	Horizontal	Horizontal
Non-RB		

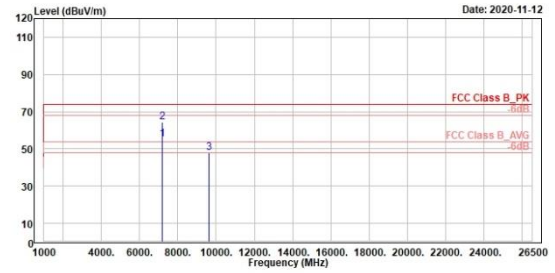

TÜV Rheinland Taiwan Ltd.
 No. 458-18, Sec. 2, Fenhiao, Linkou Dist., New Taipei City 244, Taiwan(R.O.C.)
 Tel: +886-2172-1000 Fax: +886-2172-1322



1	2	3
7286.00	7286.00	9608.00
55.32	64.27	47.86
62.97	71.92	53.15
-7.65	-7.65	-5.29
76.89	74.00	74.00
-21.57	-9.73	-26.14
181	181	400
273	273	324
Average	Peak	Peak
Vertical	Vertical	Vertical
Non-RB		

BLE_1M

Middle Channel (Horizontal)

Middle Channel (Vertical)



TUV Rheinland Taiwan Ltd.
No. 458-18, Sec. 2, Fenhiao, Linkou Dist., New Taipei City 244, Taiwan(R.O.C.)
Tel: +886-2172-1000 Fax: +886-2172-1322

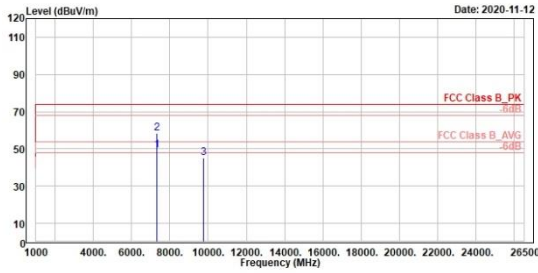

Freq	Level	Read Level	Factor	Limit Line	Over Limit	APos	TPos	Remark	Pol/Phase	Note
MHz	dBuV/m	dBuV	dB/m	dBuV/m	dB	cm	deg			
1 7320.00	49.06	56.84	-7.78	54.00	-4.94	392	237	Average	Horizontal	
2 7320.00	58.59	66.37	-7.78	74.00	-15.41	392	237	Peak	Horizontal	
3 9760.00	45.24	50.20	-4.96	74.00	-28.76	100	126	Peak	Horizontal	



TUV Rheinland Taiwan Ltd.
No. 458-18, Sec. 2, Fenhiao, Linkou Dist., New Taipei City 244, Taiwan(R.O.C.)
Tel: +886-2172-1000 Fax: +886-2172-1322

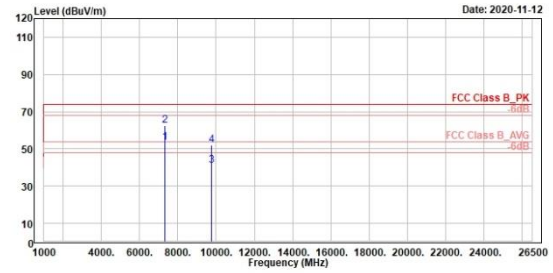

Freq	Level	Read Level	Factor	Limit Line	Over Limit	APos	TPos	Remark	Pol/Phase	Note
MHz	dBuV/m	dBuV	dB/m	dBuV/m	dB	cm	deg			
1 7320.00	53.49	61.27	-7.78	54.00	-0.51	100	268	Average	Vertical	
2 7320.00	62.36	70.14	-7.78	74.00	-11.64	100	268	Peak	Vertical	
3 9760.00	40.93	45.89	-4.96	54.00	-13.07	100	266	Average	Vertical	
4 9760.00	51.98	56.94	-4.96	74.00	-22.02	100	266	Peak	Vertical	

BLE_1M

High Channel (Horizontal)

High Channel (Vertical)



TUV Rheinland Taiwan Ltd.
No. 458-18, Sec. 2, Fenhiao, Linkou Dist., New Taipei City 244, Taiwan(R.O.C.)
Tel: +886-2172-1000 Fax: +886-2172-1322



TUV Rheinland Taiwan Ltd.
No. 458-18, Sec. 2, Fenhiao, Linkou Dist., New Taipei City 244, Taiwan(R.O.C.)
Tel: +886-2172-1000 Fax: +886-2172-1322

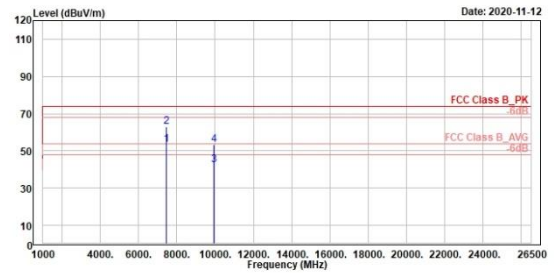
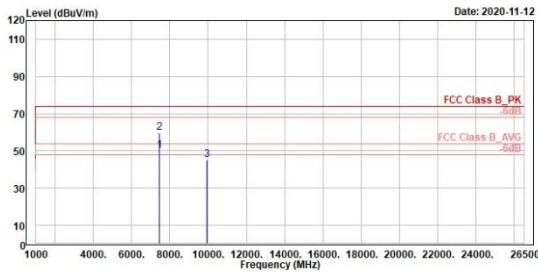

1	2	3	4	5	6	7	8	9	10	11	12	13	14	15	16	17	18	19	20
1	Level	Read	Level	Factor	Limit	Over	Apos	TPos	Remark	Pol/Phase	Note								
1	Freq	Level	Level	Factor	Line	Limit	cm	deg											
1	MHz	dBuV/m	dBuV	dB/m	dBuV/m	dB	cm	deg											
1	7440.00	50.39	58.11	-7.72	54.00	-3.61	355	254	Average	Horizontal									
2	7440.00	59.72	67.44	-7.72	74.00	-14.28	355	254	Peak	Horizontal									
3	9920.00	45.26	49.94	-4.68	74.00	-28.74	100	121	Peak	Horizontal									

1	2	3	4	5	6	7	8	9	10	11	12	13	14	15	16	17	18	19	20
1	Level	Read	Level	Factor	Limit	Over	Apos	TPos	Remark	Pol/Phase	Note								
1	Freq	Level	Level	Factor	Line	Limit	cm	deg											
1	MHz	dBuV/m	dBuV	dB/m	dBuV/m	dB	cm	deg											
1	7440.00	53.55	61.27	-7.72	54.00	-0.45	100	267	Average	Vertical									
2	7440.00	63.17	70.89	-7.72	74.00	-10.83	100	267	Peak	Vertical									
3	9920.00	42.59	47.27	-4.68	54.00	-11.41	104	266	Average	Vertical									
4	9920.00	53.57	58.25	-4.68	74.00	-20.43	104	266	Peak	Vertical									

BLE_2M

Low Channel (Horizontal)

Low Channel (Vertical)



TUV Rheinland Taiwan Ltd.
No. 458-18, Sec. 2, Fenhiao, Linkou Dist., New Taipei City 244, Taiwan(R.O.C.)
Tel: +886-2172-1000 Fax: +886-2172-1322

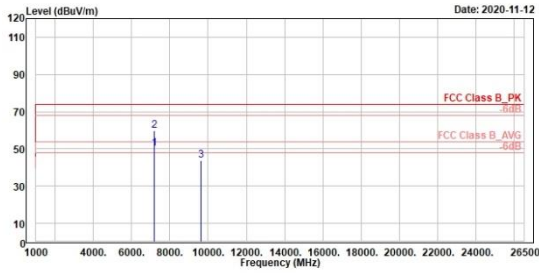

Line	Freq	Level	Read Level	Factor	Limit Line	Over Limit	APos	TPos	Remark	Pol/Phase	Note
	MHz	dBuV/m	dBuV	dB/m	dBuV/m	dB	cm	deg			
1	7286.00	50.16	57.81	-7.65	75.23	-25.07	310	237	Average	Horizontal	Non-RB
2	7286.00	59.78	67.43	-7.65	78.02	-18.24	310	237	Peak	Horizontal	Non-RB
3	9608.00	43.67	48.96	-5.29	74.00	-30.33	100	120	Peak	Horizontal	



TUV Rheinland Taiwan Ltd.
No. 458-18, Sec. 2, Fenhiao, Linkou Dist., New Taipei City 244, Taiwan(R.O.C.)
Tel: +886-2172-1000 Fax: +886-2172-1322

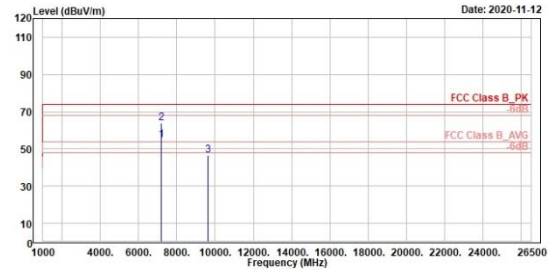

Line	Freq	Level	Read Level	Factor	Limit Line	Over Limit	APos	TPos	Remark	Pol/Phase	Note
	MHz	dBuV/m	dBuV	dB/m	dBuV/m	dB	cm	deg			
1	7286.00	54.53	62.18	-7.65	74.88	-20.35	100	272	Average	Vertical	Non-RB
2	7286.00	63.85	71.50	-7.65	77.84	-13.99	100	272	Peak	Vertical	Non-RB
3	9608.00	46.43	51.72	-5.29	74.00	-27.57	100	322	Peak	Vertical	

BLE_2M

Middle Channel (Horizontal)

Middle Channel (Vertical)



TUV Rheinland Taiwan Ltd.
No. 458-18, Sec. 2, Fenhiao, Linkou Dist., New Taipei City 244, Taiwan(R.O.C.)
Tel: +886-2172-1000 Fax: +886-2172-1322

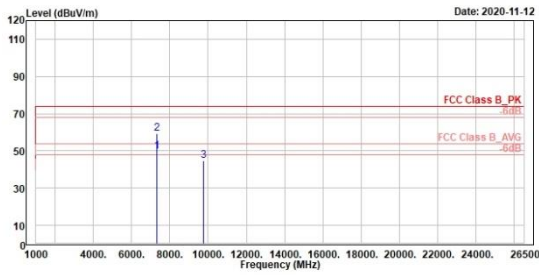

1	2	3
Level	Level	Level
Factor	Factor	Factor
Line	Line	Line
Limit	Limit	Limit
Over	Over	Over
Limit	Limit	Limit
Apos	Apos	Apos
TPos	TPos	TPos
Remark	Remark	Remark
Pol/Phase	Pol/Phase	Pol/Phase
Note	Note	Note
1 7320.00	49.71	57.49
2 7320.00	59.15	66.93
3 9760.00	44.94	49.90



TUV Rheinland Taiwan Ltd.
No. 458-18, Sec. 2, Fenhiao, Linkou Dist., New Taipei City 244, Taiwan(R.O.C.)
Tel: +886-2172-1000 Fax: +886-2172-1322

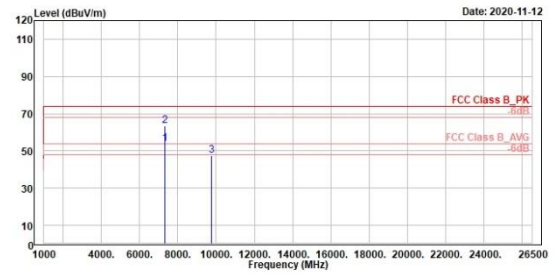

1	2	3
Level	Level	Level
Factor	Factor	Factor
Line	Line	Line
Limit	Limit	Limit
Over	Over	Over
Limit	Limit	Limit
Apos	Apos	Apos
TPos	TPos	TPos
Remark	Remark	Remark
Pol/Phase	Pol/Phase	Pol/Phase
Note	Note	Note
1 7320.00	53.67	61.45
2 7320.00	63.24	71.02
3 9760.00	47.42	52.38

BLE_2M
High Channel (Horizontal)
High Channel (Vertical)

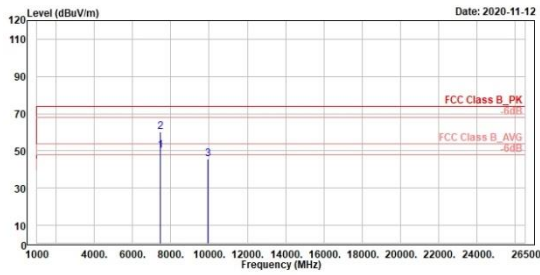

TÜV Rheinland Taiwan Ltd.
 No. 458-18, Sec. 2, Fenhiao, Linkou Dist., New Taipei City 244, Taiwan(R.O.C.)
 Tel: +886-2172-1000 Fax: +886-2172-1322



1	2	3								
Level	Level	Level								
Factor	Factor	Factor								
Limit	Limit	Limit								
Line	Line	Line								
Over	Over	Over								
Limit	Limit	Limit								
Apos	Apos	Apos								
TPos	TPos	TPos								
Remark	Remark	Remark								
Pol/Phase	Pol/Phase	Pol/Phase								
Note	Note	Note								
1 7440.00	58.24	57.96	-7.72	54.00	-3.76	374	249	Average	Horizontal	
2 7440.00	68.03	67.75	-7.72	74.00	-13.97	374	249	Peak	Horizontal	
3 9920.00	45.60	50.28	-4.68	74.00	-28.40	100	123	Peak	Horizontal	

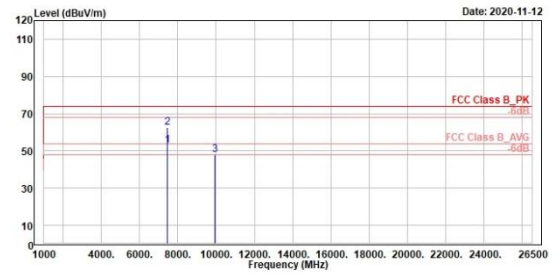

TÜV Rheinland Taiwan Ltd.
 No. 458-18, Sec. 2, Fenhiao, Linkou Dist., New Taipei City 244, Taiwan(R.O.C.)
 Tel: +886-2172-1000 Fax: +886-2172-1322



1	2	3								
Level	Level	Level								
Factor	Factor	Factor								
Limit	Limit	Limit								
Line	Line	Line								
Over	Over	Over								
Limit	Limit	Limit								
Apos	Apos	Apos								
TPos	TPos	TPos								
Remark	Remark	Remark								
Pol/Phase	Pol/Phase	Pol/Phase								
Note	Note	Note								
1 7440.00	53.09	68.81	-7.72	54.00	-0.91	100	267	Average	Vertical	
2 7440.00	62.68	78.40	-7.72	74.00	-11.32	100	267	Peak	Vertical	
3 9920.00	47.88	52.56	-4.68	74.00	-26.12	100	269	Peak	Vertical	