

| | | | | | |
|--|--|---|--|---|---|
| Prüfbericht-Nr.: <i>Test Report No.:</i> | 50110281 001 | Auftrags-Nr.: <i>Order No.:</i> | 114070033 | Seite 1 von 32 <i>Page 1 of 32</i> | |
| Kunden-Referenz-Nr.: <i>Client Reference No.:</i> | N/A | Auftragsdatum: <i>Order date:</i> | 11-Sep-2017 | | |
| Auftraggeber: <i>Client:</i> | Elgato Systems LLC 900 Kearny St., Suite 750, CA 94133, USA | | | | |
| Prüfgegenstand: <i>Test item:</i> | Eve Button | | | | |
| Bezeichnung / Typ-Nr.: <i>Identification / Type No.:</i> | 20EAU9901 | | | | |
| Auftrags-Inhalt: <i>Order content:</i> | FCC Part15C / IC RSS-247 Test report (BLE) | | | | |
| Prüfgrundlage: <i>Test specification:</i> | FCC 47 CFR Part 15: Subpart C Section 15.247 FCC 47 CFR Part 2: Subpart J Section 2.1091 RSS-247 (02-2017) | | | | |
| Wareneingangsdatum: <i>Date of receipt:</i> | 21-Oct-2017 | | | | |
| Prüfmuster-Nr.: <i>Test sample No.:</i> | A000632733-001 A000632733-002 | | | | |
| Prüfzeitraum: <i>Testing period:</i> | 23-Oct-2017 - 9-Nov-2017 | | | | |
| Ort der Prüfung: <i>Place of testing:</i> | EMC/RF Laboratory Taipei | | | | |
| Prüflaboratorium: <i>Testing laboratory:</i> | TUV Rheinland Taiwan Ltd. | | | | |
| Prüfergebnis*: <i>Test result*:</i> | Pass | | | | |
| Report Date / tested by: |  | | kontrolliert von / reviewed by: |  | |
| 2017-12-11 SamC.J. Kuo/Engineer | | | 2017-12-11 Arvin Ho/Vice General Manager | | |
| Datum <i>Date</i> | Name / Stellung <i>Name / Position</i> | Unterschrift <i>Signature</i> | Datum <i>Date</i> | Name / Stellung <i>Name / Position</i> | Unterschrift <i>Signature</i> |
| Sonstiges / Other: | | | | | |
| Zustand des Prüfgegenstandes bei Anlieferung: <i>Condition of the test item at delivery:</i> | | | Prüfmuster vollständig und unbeschädigt <i>Test item complete and undamaged</i> | | |
| * Legende: 1 = sehr gut 2 = gut 3 = befriedigend 4 = ausreichend 5 = mangelhaft P(ass) = entspricht o.g. Prüfgrundlage(n) F(ail) = entspricht nicht o.g. Prüfgrundlage(n) N/A = nicht anwendbar N/T = nicht getestet Legend: 1 = very good 2 = good 3 = satisfactory 4 = sufficient 5 = poor P(ass) = passed a.m. test specification(s) F(ail) = failed a.m. test specification(s) N/A = not applicable N/T = not tested | | | | | |
| Dieser Prüfbericht bezieht sich nur auf das o.g. Prüfmuster und darf ohne Genehmigung der Prüfstelle nicht auszugsweise vervielfältigt werden. Dieser Bericht berechtigt nicht zur Verwendung eines Prüfzeichens. <i>This test report only relates to the a. M. Test sample. Without permission of the test center this test report is not permitted to be duplicated in extracts. This test report does not entitle to carry any test mark.</i> | | | | | |

TEST SUMMARY

5.1.1 ANTENNA REQUIREMENT

RESULT: *Passed*

5.1.2 PEAK OUTPUT POWER

RESULT: *Passed*

5.1.3 6dB BANDWIDTH 99% BANDWIDTH

RESULT: *Passed*

5.1.4 POWER DENSITY

RESULT: *Passed*

5.1.5 CONDUCTED SPURIOUS EMISSIONS AND FREQUENCY BAND EDGE MEASURED IN 100KHZ BANDWIDTH

RESULT: *Passed*

5.1.6 SPURIOUS EMISSION

RESULT: *Passed*

6.1.1 ELECTROMAGNETIC FIELDS

RESULT: *Passed*

Contents

| | | |
|--------------|---|-----------|
| 1. | GENERAL REMARKS | 5 |
| 1.1 | COMPLEMENTARY MATERIALS..... | 5 |
| 2. | TEST SITES | 6 |
| 2.1 | TEST FACILITY..... | 6 |
| 2.2 | LIST OF TEST AND MEASUREMENT INSTRUMENTS..... | 7 |
| 2.3 | TRACEABILITY | 8 |
| 2.4 | CALIBRATION | 8 |
| 2.5 | MEASUREMENT UNCERTAINTY | 8 |
| 3. | GENERAL PRODUCT INFORMATION..... | 9 |
| 3.1 | PRODUCT FUNCTION AND INTENDED USE | 9 |
| 3.2 | SYSTEM DETAILS AND RATINGS..... | 9 |
| 3.3 | INDEPENDENT OPERATION MODES..... | 10 |
| 3.4 | NOISE GENERATING AND NOISE SUPPRESSING PARTS | 10 |
| 3.5 | SUBMITTED DOCUMENTS..... | 10 |
| 4. | TEST SET-UP AND OPERATION MODES..... | 11 |
| 4.1 | PRINCIPLE OF CONFIGURATION SELECTION | 11 |
| 4.2 | TEST OPERATION AND TEST SOFTWARE..... | 11 |
| 4.3 | SPECIAL ACCESSORIES AND AUXILIARY EQUIPMENT | 11 |
| 4.4 | COUNTERMEASURES TO ACHIEVE EMC COMPLIANCE..... | 12 |
| 4.5 | TEST SETUP DIAGRAM | 12 |
| 5. | TEST RESULTS | 15 |
| 5.1 | TRANSMITTER REQUIREMENT & TEST SUITES..... | 15 |
| 5.1.1 | <i>Antenna Requirement</i> | <i>15</i> |
| 5.1.2 | <i>Peak Output Power</i> | <i>16</i> |
| 5.1.3 | <i>6dB Bandwidth 99% Bandwidth</i> | <i>17</i> |
| 5.1.4 | <i>Power Density</i> | <i>20</i> |
| 5.1.5 | <i>Conducted spurious emissions and Frequency Band Edge measured in 100kHz Bandwidth.....</i> | <i>23</i> |
| 5.1.6 | <i>Spurious Emission</i> | <i>27</i> |
| 6. | SAFETY HUMAN EXPOSURE | 28 |
| 6.1 | RADIO FREQUENCY EXPOSURE COMPLIANCE | 28 |
| 6.1.1 | <i>Electromagnetic Fields.....</i> | <i>28</i> |
| 7. | PHOTOGRAPHS OF THE TEST SET-UP..... | 29 |

| | | |
|-----------|---------------------------------|-----------|
| 8. | LIST OF TABLES | 32 |
| 9. | LIST OF PHOTOGRAPHS..... | 32 |

1. General Remarks

1.1 Complementary Materials

These attachments are integral parts of this test report:

Appendix P: Photo Documentation internal view
(File Name: 50110281APPENDIXP)

Appendix D: Test Result of Radiated Emissions
(File Name: 50110281APPENDIXD)

Test Specifications

The following standards were applied.

Table 1: Applied Standard and Test Levels

| Radio |
|--|
| FCC 47 CFR Part 15: Subpart C Section 15.247 |
| FCC 47 CFR Part 2: Subpart J Section 2.1091 |
| RSS-247 Issue 2 (Feb 2017) |
| RSS-Gen, Issue 4, November 2014 |
| ANSI C63.10:2013 |
| KDB558074 D01 DTS Meas Guidance v03r05 |
| KDB447498 D01 General RF Exposure Guidance v06 |

2. Test Sites

2.1 Test Facility

TUV Rheinland Taiwan Ltd.
Taipei Office

11F. No.758, Sec. 4, Bade Rd., Songshan Dist.
Taipei City 105
Taiwan (R.O.C.)

FCC RegistrationNo.: 340738
IC Canada Registration No.: 9465A-1
TAF Accredited NCC Test Lab. No.:0759
TAF ISO17025 Certification effective periods: 2016-Jul-1st to 2019-Jun-30th



Testing Laboratory
0759

2.2 List of Test and Measurement Instruments

Table 2: List of Test and Measurement Equipment

| Kind of Equipment | Manu-facturer | Type | S/N | Last Calibration | Next Calibration |
|-------------------------------|----------------|-------------------|-------------|------------------|------------------|
| Test Software | Farad | EZ_EMC | Ver. TUV3A1 | N/A | N/A |
| EMI Test Receiver | R&S | ESCI 7 | 100797 | 2016/12/30 | 2017/12/30 |
| Spectrum Analyzer | R&S | FSV 40 | 100921 | 2017/05/02 | 2018/05/01 |
| Spectrum Analyzer | Agilent | N9010A | MY53470241 | 2017/05/23 | 2018/05/22 |
| Preamplifier (30MHz -1GHz) | HP | 8447D | 2944A06641 | 2016/12/28 | 2017/12/28 |
| Preamplifier (18 GHz -40 GHz) | COM-POWER | PAM-840 | 461257 | 2016/12/01 | 2017/12/01 |
| Pre-Amplifier (1GHz~18GHz) | EM Electronics | EM01G18G | 060558 | 2016/11/17 | 2017/11/17 |
| Bilog Antenna | TESEQ | CBL6111D | 29802 | 2017/07/12 | 2018/07/12 |
| Horn Antenna | ETS-Lindgren | 3117 | 138160 | 2017/05/25 | 2018/05/25 |
| Horn Antenna (18GHz~40GHz) | COM-POWER | AH-840 | 101031 | 2016/11/22 | 2017/11/22 |
| Loop Antenna | Schwarzbeck | FMZB 1513 | 1513-076 | 2017/06/14 | 2018/06/14 |
| EMI Test Receiver | R&S | ESCI7 | 100797 | 2016/12/30 | 2017/12/30 |
| Bluetooth Tester | R&S | CBT | 100866 | 2017/03/09 | 2018/03/08 |
| Temp. & Humid. Chamber | Giant Force | GCT-099-40-S | MAF0103-007 | 2017/03/09 | 2019/03/09 |
| Test Software | Audix | e3 | Ver. 9 | N/A | N/A |
| Test Software | Agilent | 300328 testsystem | V2.1.1 | N/A | N/A |
| Power sensor | Agilent | U2021XA | MY54020001 | 2017/03/08 | 2018/03/07 |

2.3 Traceability

All measurement equipment calibrations are traceable to NML(Taiwan)/NIST(USA) or where calibration is performed outside Taiwan, to equivalent nationally recognized standards organizations.

2.4 Calibration

Equipment requiring calibration is calibrated periodically in a suitably accredited Calibration Lab. Additionally all equipment is verified for proper performance on a regular schedule using in house standards or comparisons.

2.5 Measurement Uncertainty

The estimated combined standard uncertainty for radiated emissions and conducted emissions measurements.

Table 3: Emission Measurement Uncertainty

| Parameter | Uncertainty |
|-------------------------------|------------------------|
| Radio Frequency | $\pm 1 \times 10^{-7}$ |
| RF power, conducted | ± 1.5 dB |
| RF power density, conducted | ± 3 dB |
| spurious emissions, conducted | ± 3 dB |
| all emissions, radiated | ± 6 dB |
| Temperature | ± 1 °C |
| Humidity | ± 5 % |
| DC and low frequency voltages | ± 3 % |

3. General Product Information

3.1 Product Function and Intended Use

The EUT is a Eve Button. It contains a Bluetooth Low Energy compatible module enabling the user to communicate data through a Wireless interface.

For details refer to the User Guide, Data Sheet and Circuit Diagram.

3.2 System Details and Ratings

Table 4: Basic Information of EUT

| Item | EUT information |
|-------------------|-----------------|
| Kind of Equipment | Eve Button |
| Type Designation | 20EAU9901 |
| Brand Name | Elgato |
| FCC ID | SNE-TSW-001 |
| IC | 11192A-TSW001 |
| HVIN | 20EAU9901 |

Table 5: Technical Specification of EUT

| Technical Specification | Value |
|-------------------------|---------------|
| Operating Frequencies | 2402~2480 MHz |
| Channel Spacing | 2 MHz |
| Channel number | 40 |
| Operation Voltage | 3Vdc |
| Modulation | GFSK |
| Antenna gain | 2.01 dBi |

3.3 Independent Operation Modes

Basic operation modes are:

- A. Transmitting
 - 1. Low channel
 - 2. Middle channel
 - 3. High channel
- B. Receiving
- C. Standby
- D. Off

3.4 Noise Generating and Noise Suppressing Parts

Refer to the Circuit Diagram.

3.5 Submitted Documents

- Circuit Diagram
- Instruction Manual
- Rating Label
- Technical Description

4. Test Set-up and Operation Modes

4.1 Principle of Configuration Selection

The equipment under test (EUT) was configured to measure its maximum power level. The test modes were adapted accordingly in reference to the instructions for use.

4.2 Test Operation and Test Software

Setup for testing: Test samples are provided with a USB to SPI interface which makes it possible to control them through a test software installed on a notebook computer.

This software was running on the laptop computer connected to the EUT. It was used to enable the operation modes listed in section 3.3 as appropriate.

The samples were used as follows:

Conducted: **A000632733-001**

Radiation: **A000632733-002**

Full test was applied on all test modes, but only worst case was shown

4.3 Special Accessories and Auxiliary Equipment

The product has been tested together with the following additional accessories:

| Description | Manufacturer | Model No. | Serial No. |
|------------------|--------------|-----------|------------|
| Notebook(EMC-06) | Lenovo | TP00048A | PB-0F8B2 |

4.4 Countermeasures to achieve EMC Compliance

The test sample which has been tested contained the noise suppression parts as described in the Constructional Data Form or the Technical Construction File. No additional measures were employed to achieve compliance.

4.5 Test Setup Diagram

Diagram of Measurement Configuration for Radiation Test

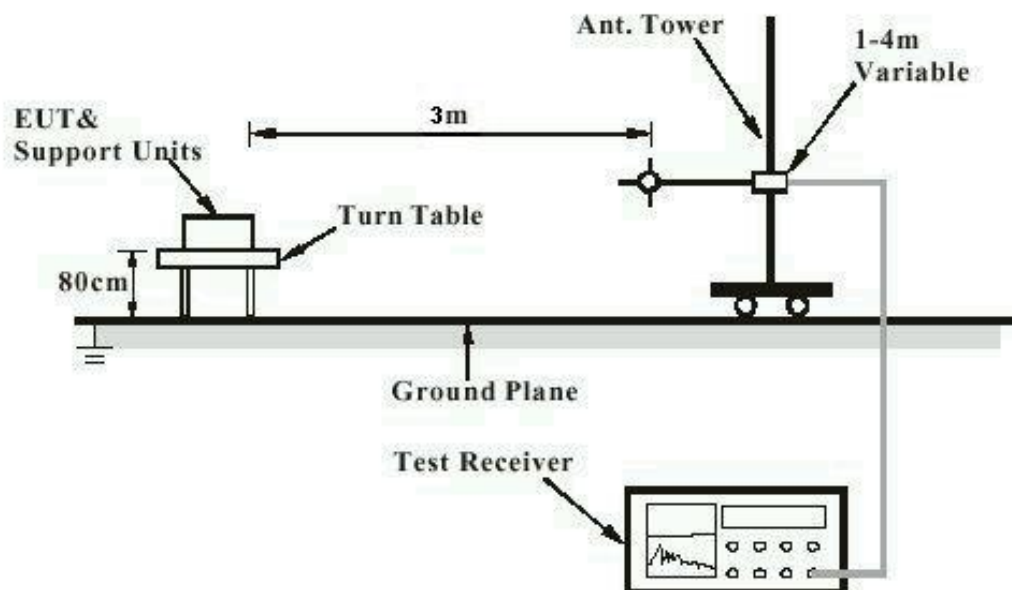

Note: Measurements above 1 GHz are done with a table height of 1.5m

Diagram of Measurement Equipment Configuration for Mains Conduction Measurement (if applicable)

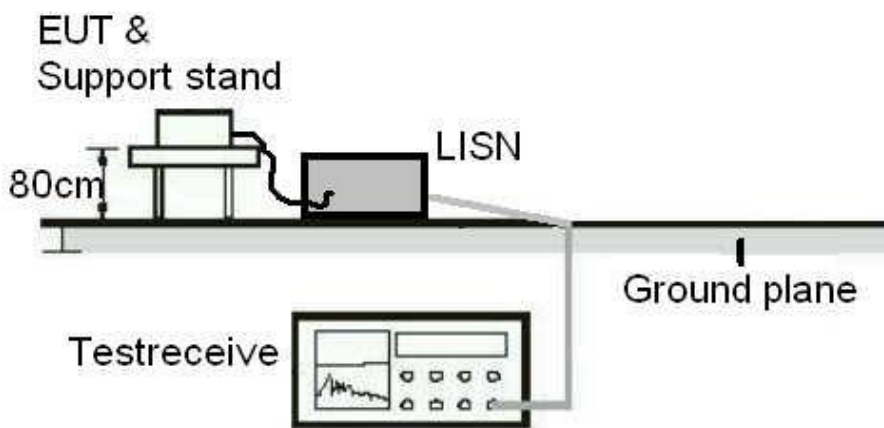

Diagram of Measurement Equipment Configuration for Conducted Transmitter Measurement

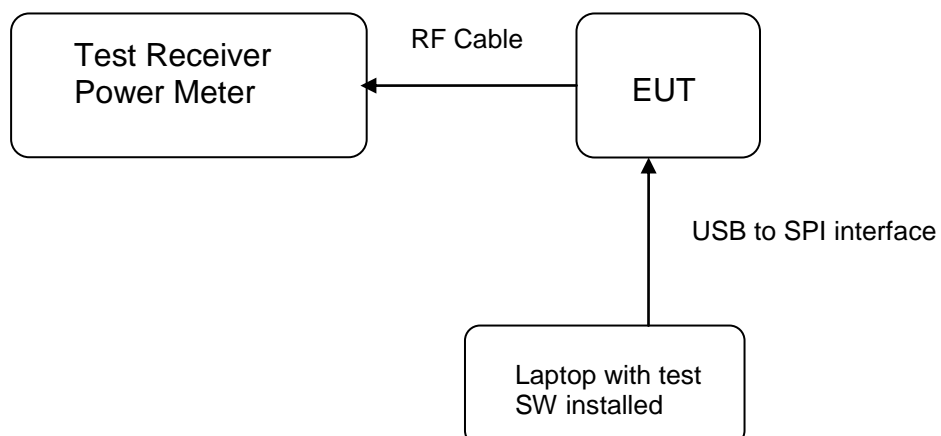
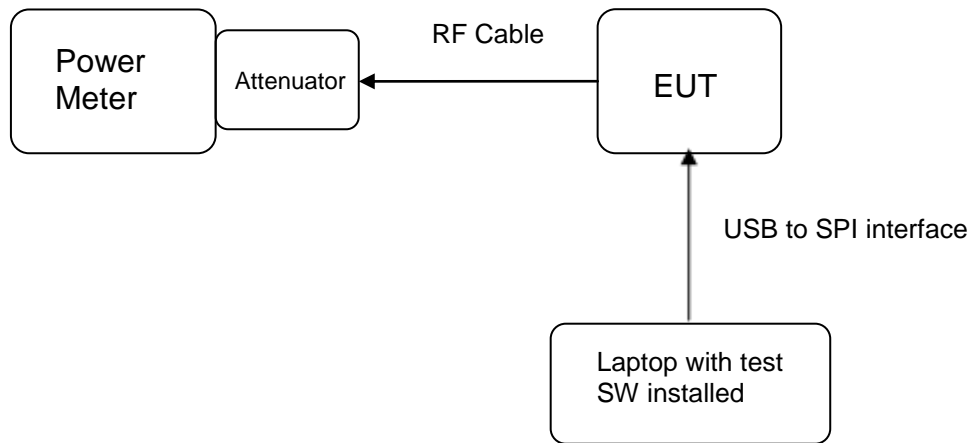

Diagram of Measurement Equipment Configuration for Conducted Transmitter Measurement (Power meter)



5. Test Results

5.1 Transmitter Requirement & Test Suites

5.1.1 Antenna Requirement

RESULT: **Passed**

| | | |
|---------------|---|---|
| Test standard | : | LP0002(2016): 2.2, 3.10.1,3 FCC Part 15.247(b)(4), Part 15.203 and RSS- Gen 8.3 |
| Requirement | : | use of approved antennas only with directional gains that do not exceed 6 dBi |

According to the manufacturer declaration, the EUT has an antenna with a directional gain of 2.01 dBi. The antenna is a Chip Antenna soldered to the PCB with no possibility of replacement with a non-approved antenna by the end-user. Therefore, the EUT is considered to comply with this provision.

Refer to EUT photo for details.

5.1.2 Peak Output Power

RESULT:
Passed

Test standard : LP0002(2016): 3.10.1.2
 FCC Part 15.247(b)(3), RSS-247 5.4(4)
 Basic standard : ANSI C63.10:2013, KDB558074
 Limit : 1 Watt
 Kind of test site : Shielded room

Test setup

Test Channel : Low/ Middle/ High
 Operation Mode : A
 Ambient temperature : 20-24°C
 Relative humidity : 50-65 %
 Atmospheric pressure : 100-103 kPa

Table 6: Test result of Peak Output Power

| Channel | Channel Frequency (MHz) | Output Power | | Limit |
|----------------|-------------------------|--------------|---------|-------|
| | | (dBm) | (W) | (W) |
| Low Channel | 2402 | -0.14 | 0.00097 | 1 |
| Middle Channel | 2440 | -0.55 | 0.00088 | 1 |
| High Channel | 2480 | -0.45 | 0.00090 | 1 |

Pmax: 0.97mW

5.1.3 6dB Bandwidth 99% Bandwidth

RESULT:
Passed

Test standard : LP0002(2016): 3.10.1.6 (2)(A)
 FCC Part 15.247(a)(2), RSS-247 5.2(1)
 Basic standard : ANSI C63.10:2013, KDB558074
 Kind of test site : Shielded room

Test setup

Test Channel : Low/ Middle/ High
 Operation Mode : A
 Ambient temperature : 20-24°C
 Relative humidity : 50-65 %
 Atmospheric pressure : 100-103 kPa

Table 7: Test result of 6dB Bandwidth

| Channel | Channel Frequency (MHz) | 6dB Bandwidth (kHz) | Limit (kHz) | Result |
|--------------|-------------------------|---------------------|-------------|--------|
| Low Channel | 2402 | 978.4 | >500 | Pass |
| Mid Channel | 2440 | 679.1 | >500 | Pass |
| High Channel | 2480 | 690 | >500 | Pass |

Table 8: Test result of 99% Bandwidth,

| Channel | Channel Frequency (MHz) | 99% Bandwidth (MHz) |
|-------------|-------------------------|---------------------|
| Mid Channel | 2440 | 1.0445 |

Test Plot of 6dB Bandwidth

Low Channel

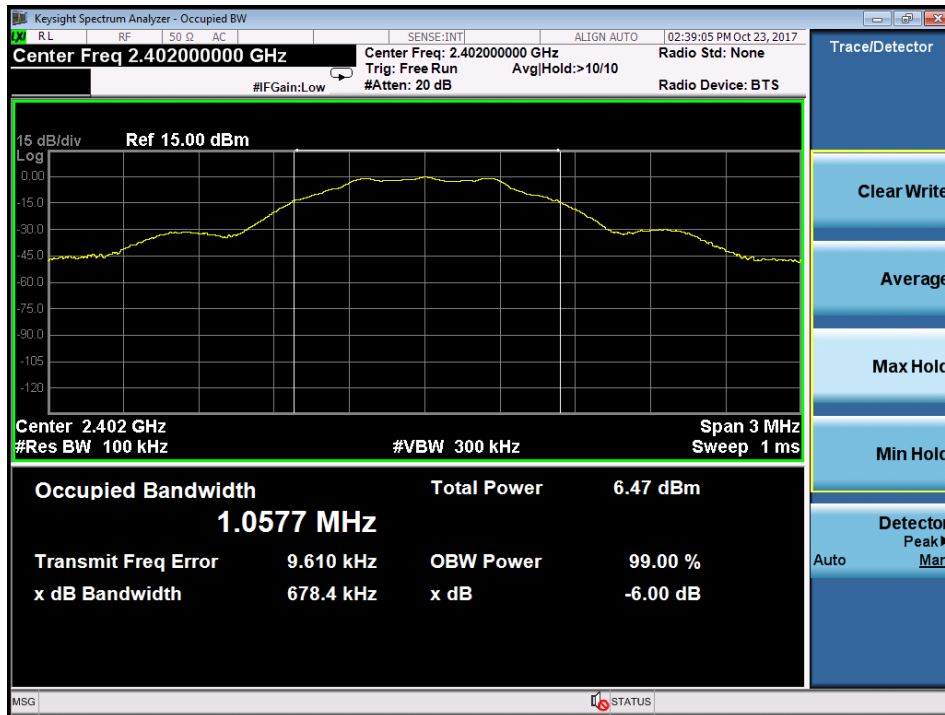

Middle Channel

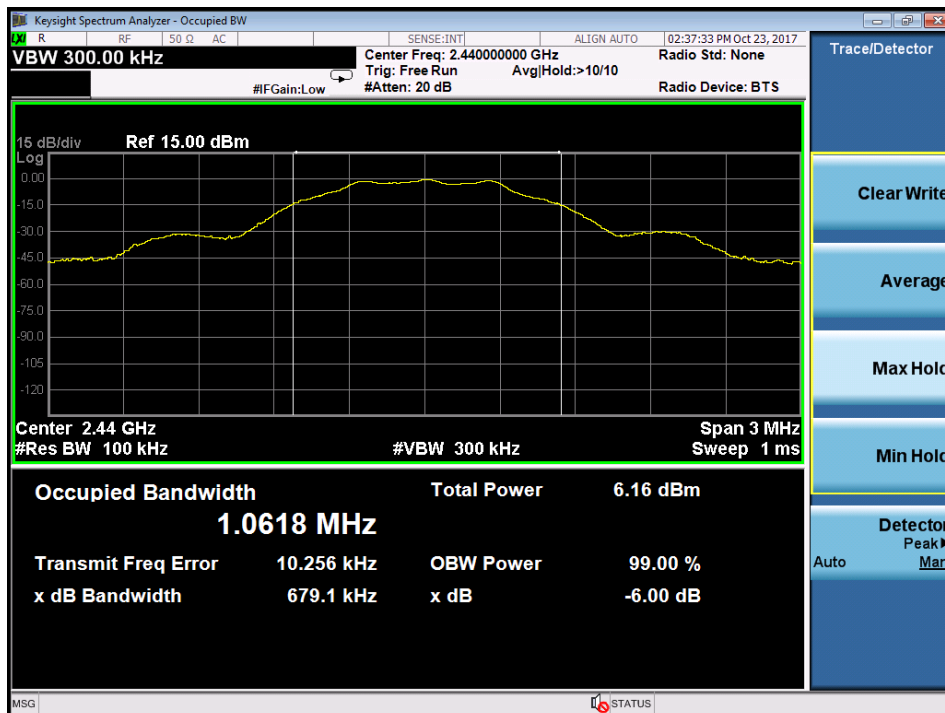

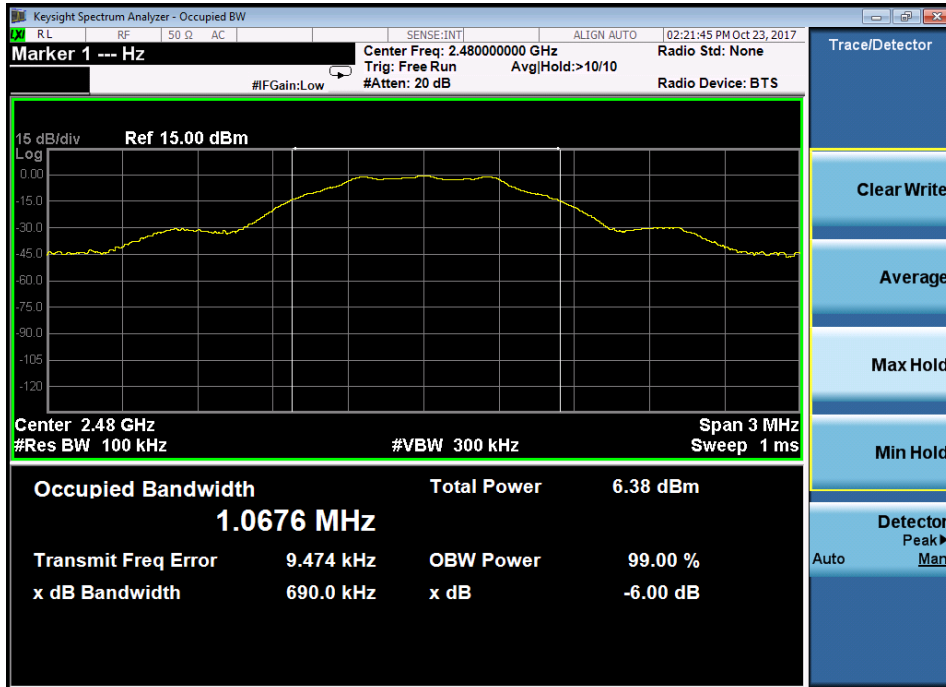
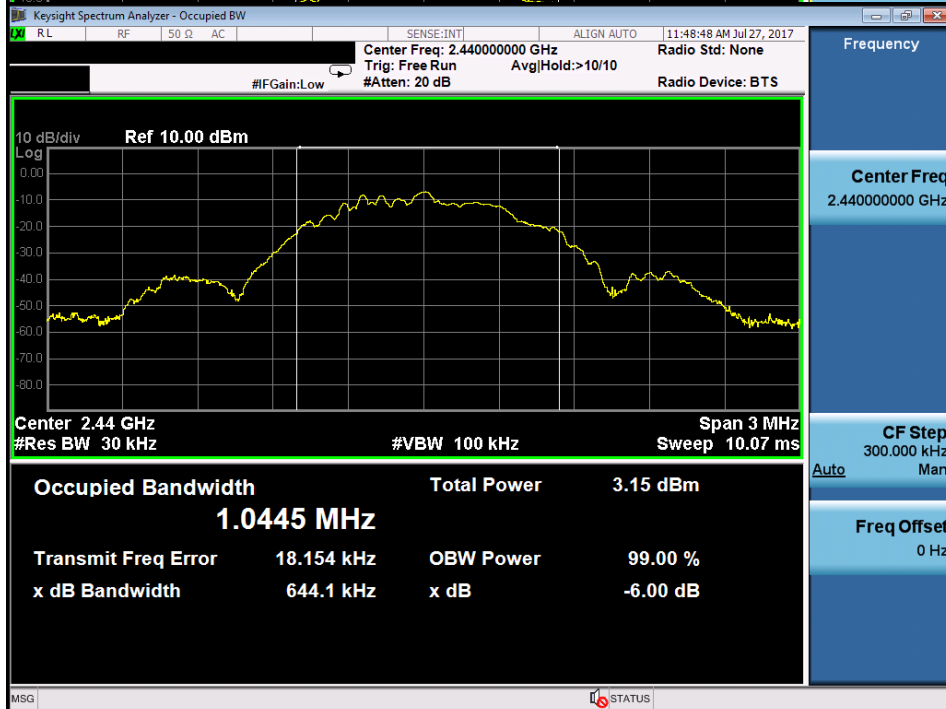
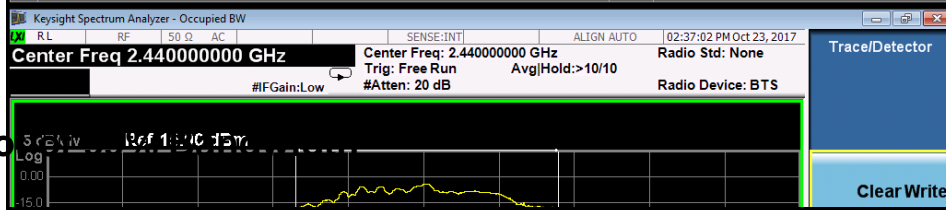
High Channel

Test Plot

5.1.4 Power Density

RESULT:
Passed

Test standard : LP0002(2016): 3.10.1,6 (2)(B)
 FCC Part 15.247(e) , RSS-247 5.2(2)
 Basic standard : ANSI C63.10:2013, KDB558074
 Kind of test site : Shielded room

Test setup

Test Channel : Low/ Middle/ High
 Operation Mode : A
 Ambient temperature : 20-24°C
 Relative humidity : 50-65 %
 Atmospheric pressure : 100-103 kPa

Table 9: Test result of Power Density

| Channel | Channel Frequency (MHz) | Power Density | Limit |
|----------------|-------------------------|---------------|-------|
| | | (dBm) | (dBm) |
| Low Channel | 2402 | -14.52 | 8 |
| Middle Channel | 2440 | -15.827 | 8 |
| High Channel | 2480 | -14.77 | 8 |

Test Plot of Power Density

Low Channel

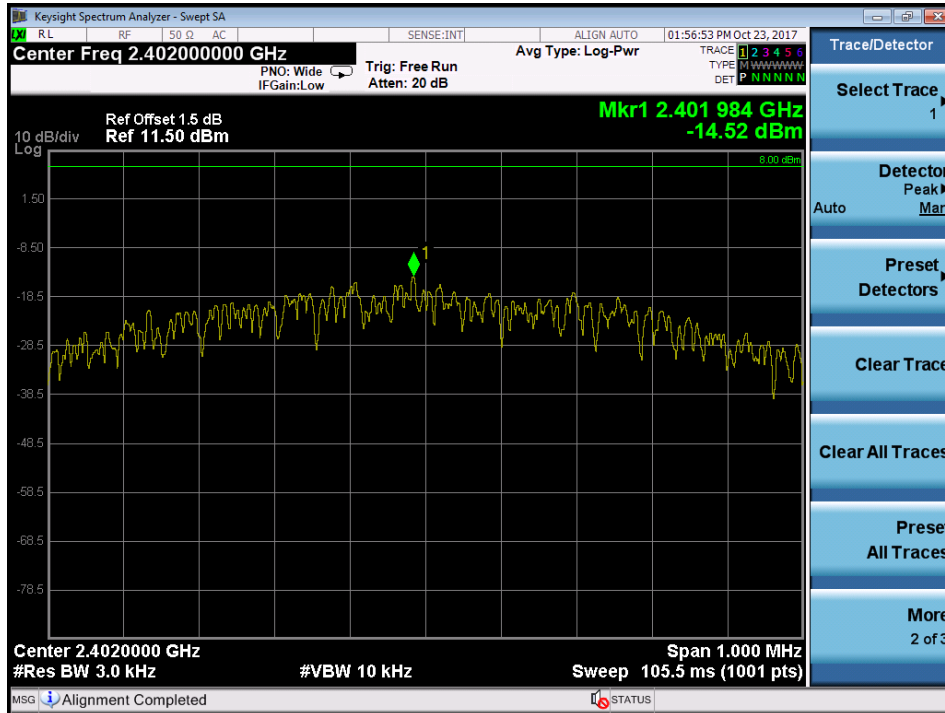

Middle Channel

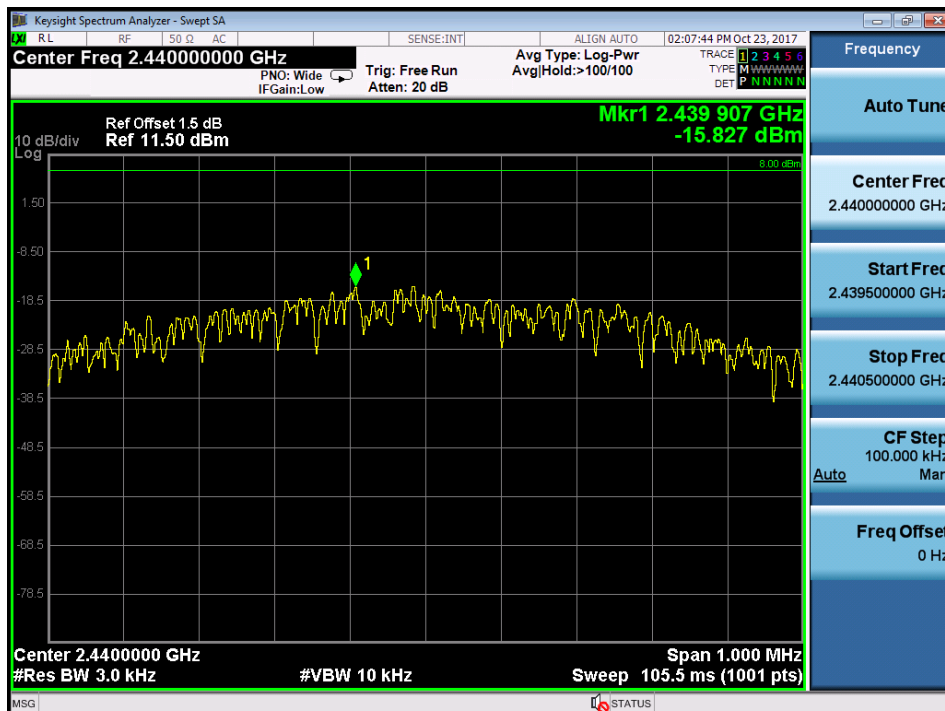

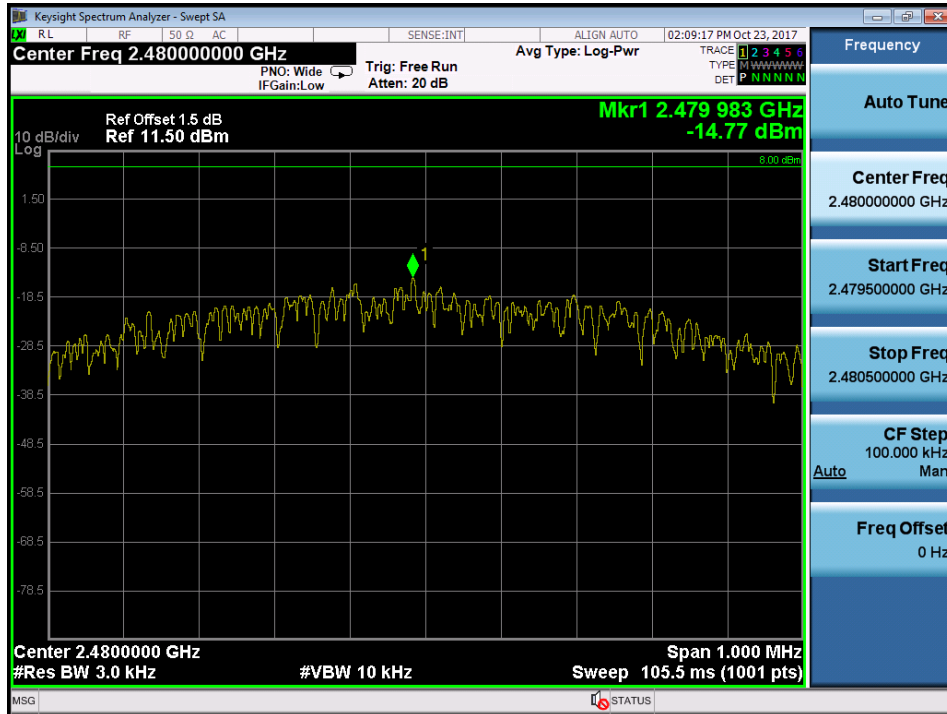
High Channel

5.1.5 Conducted spurious emissions and Frequency Band Edge measured in 100kHz Bandwidth

RESULT:**Passed**

| | | |
|-------------------|---|--|
| Test standard | : | LP0002(2016): 3.10.1.5 FCC part 15.247(d), RSS-247 5.5 |
| Basic standard | : | ANSI C63.10:2013, KDB558074 |
| Limit | : | 20dB (below that in the 100kHz bandwidth within the band that contains the highest level of the desired power) |
| Kind of test site | : | Shielded room |

Test setup

| | | |
|----------------------|---|-------------|
| Test Channel | : | Low/ High |
| Operation mode | : | A |
| Ambient temperature | : | 20-24°C |
| Relative humidity | : | 50-65 % |
| Atmospheric pressure | : | 100-103 kPa |

All emissions are more than 20dB below fundamental, details refer to following test plot, and compliance is achieved as well.

Due to the small size of the product and that there are no inductive components of significant size, 9kHz to 30MHz frequency range is not tested based on technical judgment.

Test Plot 100kHz Conducted Emissions

Low Channel



Middle Channel



High Channel

Test Plot 100kHz RBW of Band Edge

Low Channel

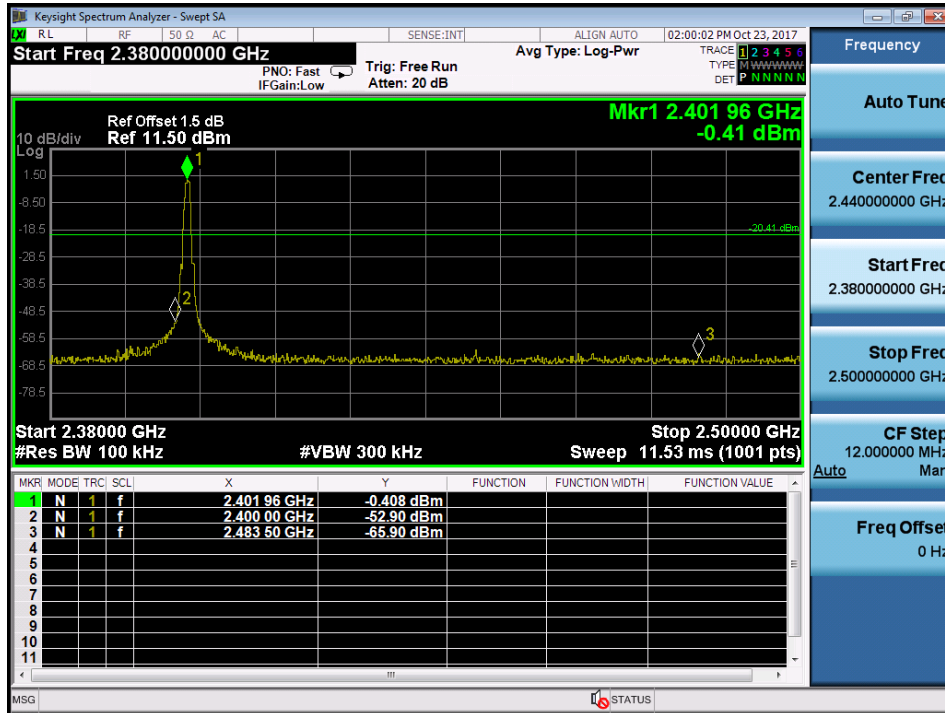

High Channel

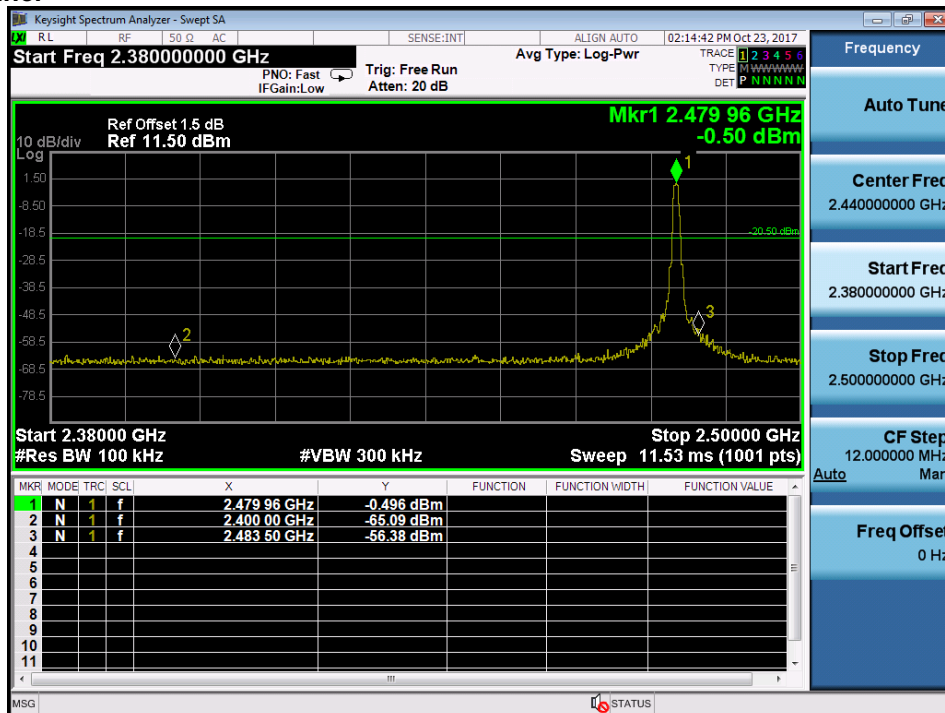

5.1.6 Spurious Emission

RESULT:**Passed**

| | | |
|-------------------|---|---|
| Test standard | : | FCC part 15.247(d), FCC 15.205, FCC 15.209, RSS-210 2.2, RSS-247 5.5 and RSS-Gen 8.9 LP0002(2016): 3.10.1.5 |
| Basic standard | : | ANSI C63.10: 2009 |
| Limits | : | Radiated emissions which fall in the restricted bands, as defined in FCC 15.205(a) and RSS-Gen i4, 8.9 (Table 6), must comply with the radiated emission limits specified in FCC 15.209(a) and RSS-Gen i4, 8.9 (Table 4 and 5). Radiated emissions which fall in the restricted bands, as defined in LP0002(2016): 2.7 , must comply with the radiated emission limits specified in LP0002(2016): 2.8 Emission radiated outside the specified frequency bands must comply with the radiated emission limits specified in FCC 15.209(a) and FCC 15.249(a), RSS-Gen i4, 8.9 (Table 4 and 5) and RSS-210 A2.9(a). Emission radiated outside the specified frequency bands must comply with the radiated emission limits specified in LP0002(2016): 2.8 |
| Kind of test site | : | 3m Semi-Anechoic Chamber |

Test setup

| | | |
|----------------|---|-------------------|
| Test Channel | : | Low/ Middle/ High |
| Operation mode | : | A, B |

Remark: Testing was carried out within frequency range 30MHz to the tenth harmonic.

For details refer to Appendix D.

Testing was carried out within frequency range 30MHz to the tenth harmonic. For details refer to Appendix D. The Radiated Emissions testing was performed in the X, Y and Z axis orientation. The worst-case Axis orientation is recorded in this test report.

6. Safety Human exposure

6.1 Radio Frequency Exposure Compliance

6.1.1 Electromagnetic Fields

RESULT:**Passed**Test standard : FCC KDB Publication 447498 D01 v06
RSS-102FCC:

Since maximum peak output power of the transmitter is 0.97mW < 10mW, hence the EUT is excluded from SAR evaluation according to FCC KDB publication 447498 D01 v05: Mobile Portable RF Exposure

Canada:

Maximum conducted peak power: 0.97 mW

Antenna Gain: 2.01 dbi -> x 1.58

Maximum EIRP available 1.4 mW

=====
Maximum Power available: 1.4 mW
(higher of EIRP or conducted)

Since maximum output power of the transmitter is 1.4mW < 4mW, hence the EUT is excluded from SAR evaluation according to Table 1 in RSS-102

7. Photographs of the Test Set-Up

Photograph 1: Set-up for Spurious Emissions (Front View)



Photograph 2: Set-up for Spurious Emissions (Back View 1)

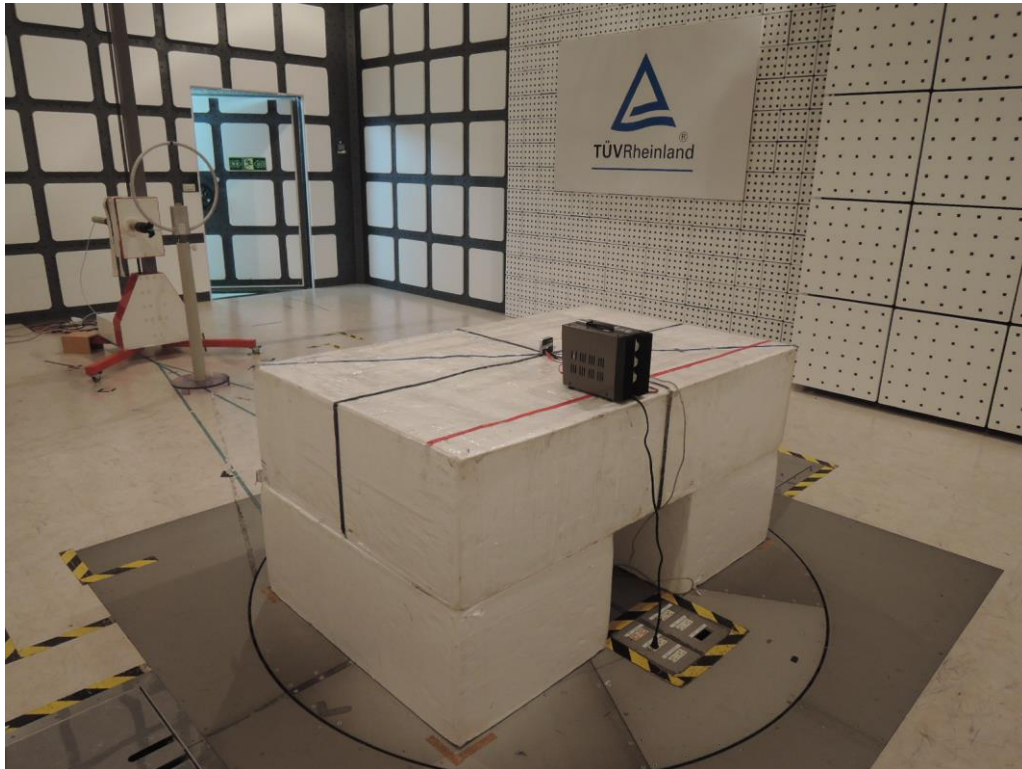

Photograph 3: Set-up for Spurious Emissions (Back View 2)

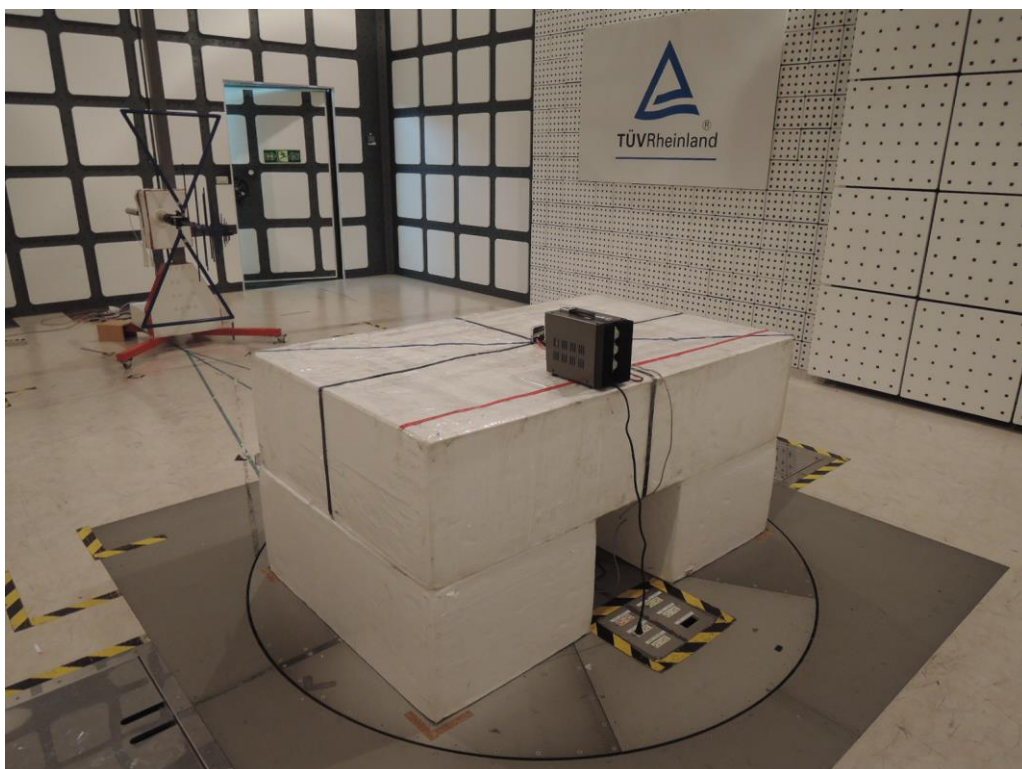

Photograph 4: Set-up for Spurious Emissions (Back View 3)

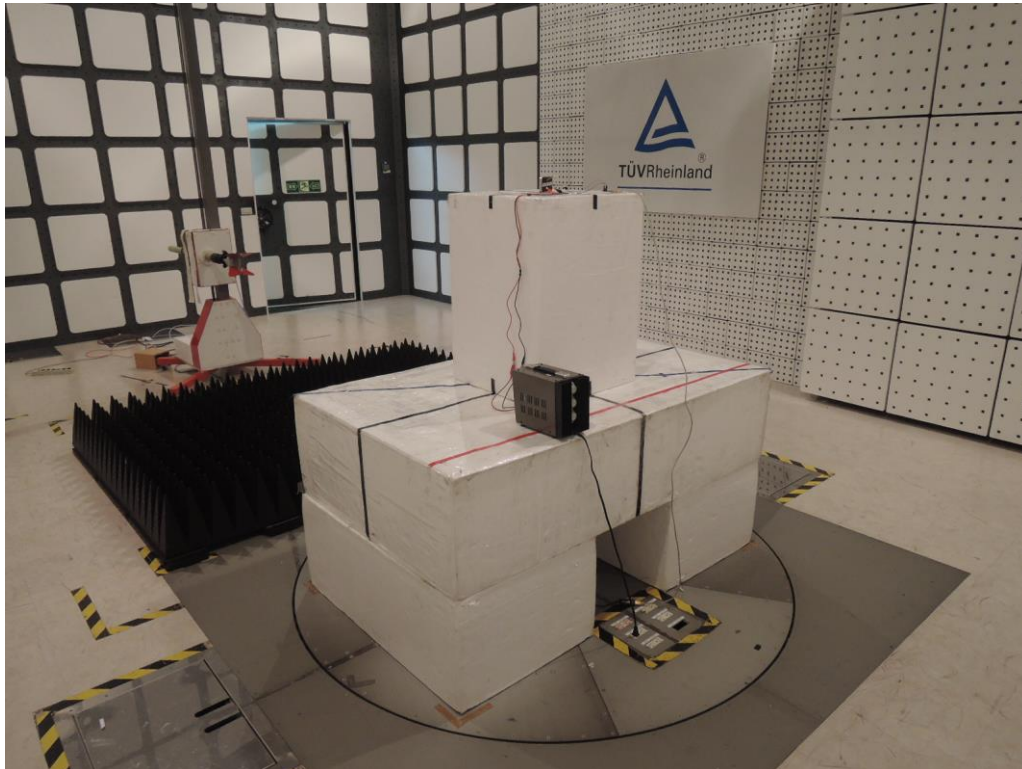

Photograph 5: Set-up for Conducted testing

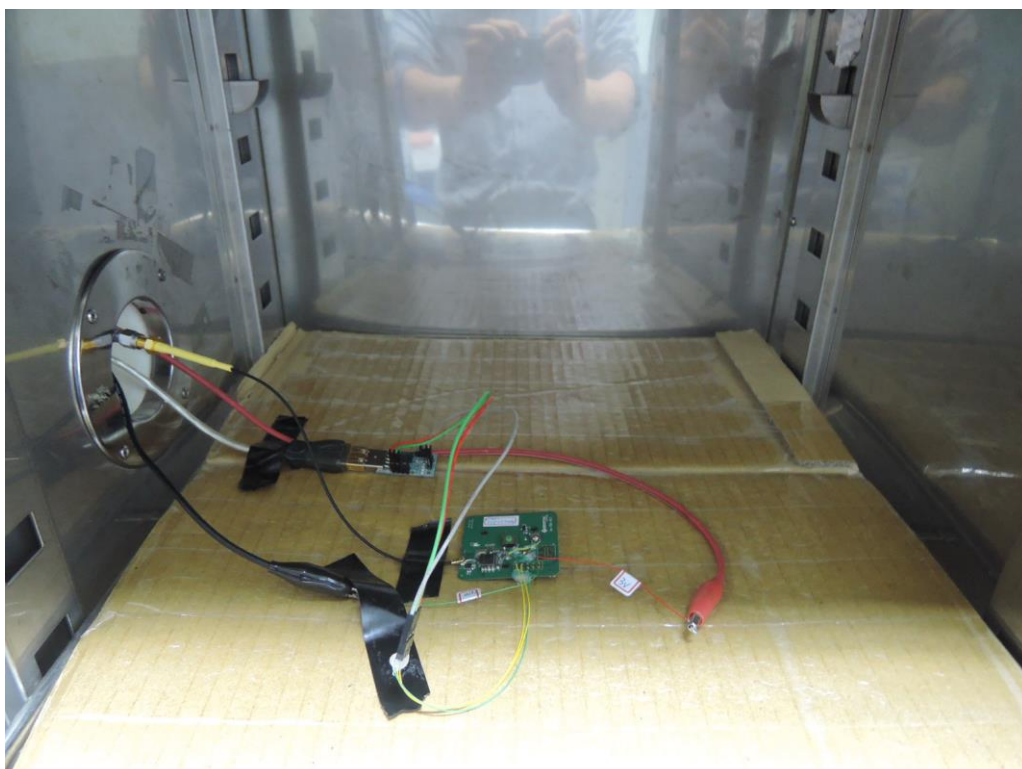

8. List of Tables

| | |
|---|----|
| Table 1: Applied Standard and Test Levels | 5 |
| Table 2: List of Test and Measurement Equipment | 7 |
| Table 3: Emission Measurement Uncertainty..... | 8 |
| Table 4: Basic Information of EUT | 9 |
| Table 5: Technical Specification of EUT | 9 |
| Table 6: Test result of Peak Output Power | 16 |
| Table 7: Test result of 6dB Bandwidth | 17 |
| Table 8: Test result of 99% Bandwidth,..... | 17 |
| Table 9: Test result of Power Density | 20 |

9. List of Photographs

| | |
|---|----|
| Photograph 1: Set-up for Spurious Emissions (Front View)..... | 29 |
| Photograph 2: Set-up for Spurious Emissions (Back View 1) | 30 |
| Photograph 3: Set-up for Spurious Emissions (Back View 2) | 30 |
| Photograph 4: Set-up for Spurious Emissions (Back View 3) | 31 |
| Photograph 5: Set-up for Conducted testing | 31 |