



| | | | | |
|--|--|--|--|---|
| Prüfbericht-Nr.: <i>Test report no.:</i> | CN23OW7Q (P15E-WiFi) 001 | Auftrags-Nr.: <i>Order no.:</i> | 48200107 | Seite 1 von 42 Page 1 of 42 |
| Kunden-Referenz-Nr.: <i>Client reference no.:</i> | N/A | Auftragsdatum: <i>Order date:</i> | 2023-04-01 | |
| Auftraggeber: <i>Client:</i> | Eve Systems LLC 100 Pine St., Suite 1250, San Francisco CA 94111 USA | | | |
| Prüfgegenstand: <i>Test item:</i> | Eve Cam | | | |
| Bezeichnung / Typ-Nr.: <i>Identification / Type no.:</i> | 20ECJ9901 | | | |
| Auftrags-Inhalt: <i>Order content:</i> | FCC Part 15E Test report (WiFi 5GHz) | | | |
| Prüfgrundlage: <i>Test specification:</i> | FCC 47CFR Part 15: Subpart E Section 15.407 | | | |
| Wareneingangsdatum: <i>Date of sample receipt:</i> | 2023-04-17 | | | |
| Prüfmuster-Nr.: <i>Test sample no.:</i> | A003457889-002, 014 A003457889-015 | | | |
| Prüfzeitraum: <i>Testing period:</i> | 2023-05-13 - 2023-06-02 | | | |
| Ort der Prüfung: <i>Place of testing:</i> | EMC/RF Taipei Testing Site | | | |
| Prüflaboratorium: <i>Testing laboratory:</i> | Taipei Testing Laboratories | | | |
| Prüfergebnis*: <i>Test result*:</i> | Pass | | | |
| zusammengestellt von: <i>compiled by:</i> |  Ryan Chen | genehmigt von: <i>authorized by:</i> |  Brenda Chen | |
| Datum: <i>Date:</i> | 2023-06-13 | Ausstellungsdatum: <i>Issue date:</i> | 2023-06-13 | |
| Stellung / Position: | Senior Project Manager | Stellung / Position: | Senior Project Manager | |
| Sonstiges / Other: | | | | |
| Zustand des Prüfgegenstandes bei Anlieferung: <i>Condition of the test item at delivery:</i> | | Prüfmuster vollständig und unbeschädigt <i>Test item complete and undamaged</i> | | |
| * Legende: | 1 = sehr gut P(ass) = entspricht o.g. Prüfgrundlage(n) | 2 = gut F(ail) = entspricht nicht o.g. Prüfgrundlage(n) | 3 = befriedigend N/A = nicht anwendbar | 4 = ausreichend N/T = nicht getestet |
| * Legend: | 1 = very good P(ass) = passed a.m. test specification(s) | 2 = good F(ail) = failed a.m. test specification(s) | 3 = satisfactory N/A = not applicable | 4 = sufficient N/T = not tested |
| Dieser Prüfbericht bezieht sich nur auf das o.g. Prüfmuster und darf ohne Genehmigung der Prüfstelle nicht auszugsweise vervielfältigt werden. Dieser Bericht berechtigt nicht zur Verwendung eines Prüfzeichens. <i>This test report only relates to the a. m. test sample. Without permission of the test center this test report is not permitted to be duplicated in extracts. This test report does not entitle to carry any test mark.</i> | | | | |

TEST SUMMARY

| Report Section | FCC Clause | Test Item | Result |
|----------------|--------------------------------|--|--------|
| 5.1.1 | 15.407(a) & 15.203 | Antenna Requirement | Pass |
| 5.1.2 | 15.407(a) | Maximum Conducted Output Power | Pass |
| 5.1.3 | 15.407(h)(1) | Transmit Power Control (TPC) | Pass |
| 5.1.4 | 15.407(a) | 26 dB Bandwidth | Pass |
| 5.1.4 | 2.1049 | 99% Occupied Bandwidth | Pass |
| 5.1.5 | 15.407(e) | 6 dB Bandwidth (U-NII-3 Band only) | Pass |
| 5.1.6 | 15.407(g) | Frequency Stability | Pass |
| 5.1.7 | 15.407(a) | Power Spectral Density | Pass |
| 5.1.8 | 15.407(b) & 15.205 & 15.209 | Radiated Spurious Emissions and Band Edges | Pass |
| 5.1.9 | 15.407(h) & KDB 905462 D02 | Dynamic Frequency Selection | Pass |
| 5.2.1 | 15.207 | Mains Conducted Emission | Pass |

Note: Determining compliance based on the results of the compliance measurement, not taking into account measurement instrumentation uncertainty.

Contents

| | |
|---|-----------|
| HISTORY OF THIS TEST REPORT | 5 |
| 1. GENERAL REMARKS | 6 |
| 1.1 COMPLEMENTARY MATERIALS..... | 6 |
| 1.2 DECISION RULE OF CONFORMITY | 6 |
| 2. TEST SITES | 7 |
| 2.1 TEST LABORATORY | 7 |
| 2.2 TEST FACILITY..... | 7 |
| 2.3 TRACEABILITY | 8 |
| 2.4 CALIBRATION | 8 |
| 2.5 MEASUREMENT UNCERTAINTY | 8 |
| 3. GENERAL PRODUCT INFORMATION..... | 9 |
| 3.1 PRODUCT FUNCTION AND INTENDED USE | 9 |
| 3.2 SYSTEM DETAILS AND RATINGS..... | 9 |
| 3.3 NOISE GENERATING AND NOISE SUPPRESSING PARTS | 10 |
| 3.4 SUBMITTED DOCUMENTS..... | 10 |
| 4. TEST SET-UP AND OPERATION MODES..... | 11 |
| 4.1 PRINCIPLE OF CONFIGURATION SELECTION | 11 |
| 4.2 CARRIER FREQUENCY AND CHANNEL..... | 12 |
| 4.3 TEST OPERATION AND TEST SOFTWARE..... | 13 |
| 4.4 SPECIAL ACCESSORIES AND AUXILIARY EQUIPMENT | 15 |
| 4.5 TEST SETUP DIAGRAM | 16 |
| 4.6 DUTY CYCLE OF TEST SIGNAL | 17 |
| 5. TEST RESULTS | 19 |
| 5.1 TRANSMITTER REQUIREMENT & TEST SUITES..... | 19 |
| 5.1.1 <i>Antenna Requirement</i> | <i>19</i> |
| 5.1.2 <i>Maximum Conducted Output Power</i> | <i>20</i> |
| 5.1.3 <i>Transmit Power Control (TPC).....</i> | <i>24</i> |
| 5.1.4 <i>26 dB Bandwidth and 99% Occupied Bandwidth.....</i> | <i>25</i> |
| 5.1.5 <i>6 dB Bandwidth (5725-5850MHz).....</i> | <i>26</i> |
| 5.1.6 <i>Frequency Stability Measurement.....</i> | <i>27</i> |
| 5.1.7 <i>Power Spectral Density.....</i> | <i>29</i> |
| 5.1.8 <i>Radiated Spurious Emissions</i> | <i>31</i> |
| 5.1.9 <i>Dynamic Frequency Selection</i> | <i>36</i> |
| 5.2 MAINS EMISSION | 41 |
| 5.2.1 <i>Mains Conducted Emission.....</i> | <i>41</i> |

Prüfbericht - Nr.: CN23OW7Q (P15E-WiFi) 001
Test Report No.

Seite 4 von 42
Page 4 of 42

APPENDIX A - TEST RESULT OF CONDUCTED

APPENDIX B - TEST RESULT OF RADIATED EMISSIONS & MAINS CONDUCTED EMISSION

APPENDIX SP - PHOTOGRAPHS OF TEST SETUP

APPENDIX EP - PHOTOGRAPHS OF EUT

Prüfbericht - Nr.: CN23OW7Q (P15E-WiFi) 001
Test Report No.

Seite 5 von 42
Page 5 of 42

HISTORY OF THIS TEST REPORT

| Report No. | Description | Date Issued |
|--------------------------|------------------|-------------|
| CN23OW7Q (P15E-WiFi) 001 | Original Release | 2023-06-13 |

1. General Remarks

1.1 Complementary Materials

All attachments are integral parts of this test report. This applies especially to the following appendix:

Appendix A - Test Result of Conducted

Appendix B - Test Result of Radiated Emissions & Mains Conducted Emission

Appendix SP - Photographs of Test Setup

Appendix EP - Photographs of EUT

Applied Standard and Test Levels

| Radio |
|--|
| FCC 47CFR Part 15: Subpart E Section 15.407 |
| FCC 47CFR Part 2: Subpart J Section 2.1049 |
| ANSI C63.10:2013 |
| KDB 789033 D02 General UNII Test Procedures New Rules v02r01 |
| KDB 905462 D02 UNII DFS Compliance Procedures New Rules v02 |

1.2 Decision Rule of Conformity

The decision rule of conformity of this test report is following the requirements of the requested standard in the quotation, and agreed among testing laboratory and manufacturer (applicant) to exclude the consideration of Measurement Uncertainty, unless it is required by the specific standard.

2. Test Sites

2.1 Test Laboratory

Taipei Testing Laboratories

11F. No.758, Sec. 4, Bade Rd., Songshan Dist.
Taipei City 105
Taiwan (R.O.C.)

2.2 Test Facility

Taipei Testing Laboratories

No.458-18, Sec. 2, Fenliao Rd., Linkou Dist.,
New Taipei City 244
Taiwan (R.O.C.)
FCC Registration No.: 180491
ISED Registration No.: 25563

2.3 Traceability

All measurement equipment calibrations are traceable to NML(Taiwan)/NIST(USA) or where calibration is performed outside Taiwan, to equivalent nationally recognized standards organizations.

2.4 Calibration

Equipment requiring calibration is calibrated periodically in a suitably accredited Calibration Lab. Additionally all equipment is verified for proper performance on a regular basis using in house standards or comparisons.

2.5 Measurement Uncertainty

All measurement uncertainty values are shown with a coverage factor of $k=2$ to indicate a 95% level of confidence.

Emission Measurement Uncertainty

| Parameter | Uncertainty |
|--------------------------------------|---------------|
| Radiated Emission (9 kHz ~ 30 MHz) | ± 1.15 dB |
| Radiated Emission (30 MHz ~ 200 MHz) | ± 1.30 dB |
| Radiated Emission (200 MHz ~ 1 GHz) | ± 1.30 dB |
| Radiated Emission (1 GHz ~ 18 GHz) | ± 1.54 dB |
| Radiated Emission (18 GHz ~ 40 GHz) | ± 2.52 dB |
| Mains Conducted Emission | ± 1.65 dB |

3. General Product Information

3.1 Product Function and Intended Use

The EUT is an Eve Cam. It contains a WLAN compatible module enabling the user to communicate data through a Wireless interface.

For details refer to the User Guide, Data Sheet and Circuit Diagram.

3.2 System Details and Ratings

Basic Information of EUT

| Item | EUT information |
|-----------------------------|-----------------|
| Kind of Equipment/Test Item | Eve Cam |
| Type Identification | 20ECJ9901 |
| FCC ID | SNE-IDC-002 |

Technical Specification of EUT

| Item | EUT information |
|---------------------|--|
| Operating Frequency | Band 1: 5180 MHz ~ 5240 MHz Band 2: 5260 MHz ~ 5320 MHz Band 3: 5500 MHz ~ 5700 MHz Band 4: 5745 MHz ~ 5825 MHz |
| Channel Number | Band 1: 4 for 802.11a, 802.11n HT20, 802.11ac VHT20 2 for 802.11n HT40, 802.11ac VHT40 1 for 802.11ac VHT80 Band 2: 4 for 802.11a, 802.11n HT20, 802.11ac VHT20 2 for 802.11n HT40, 802.11ac VHT40 1 for 802.11ac VHT80 Band 3: 8 for 802.11a, 802.11n HT20, 802.11ac VHT20 4 for 802.11n HT40, 802.11ac VHT40 1 for 802.11ac VHT80 Band 4: 5 for 802.11a, 802.11n HT20, 802.11ac VHT20 2 802.11n HT40, 802.11ac VHT40 1 for 802.11ac VHT80 |
| Data Rate | 802.11a: 54.0 / 48.0 / 36.0 / 24.0 / 18.0 / 12.0 / 9.0 / 6.0 Mbps 802.11n: up to MCS7 802.11ac: up to MCS9 |
| Operation Voltage | 5Vdc |
| Modulation | OFDM (BPSK, QPSK, 16QAM, 64QAM, 256QAM) |

| Item | EUT information |
|---------------------------|--|
| Maximum Output Power (mW) | 5180 ~ 5240 MHz: 66.37 5260 ~ 5320 MHz: 62.37 5500 ~ 5720 MHz: 62.52 5745 ~ 5825 MHz: 59.43 |
| Maximum EIRP (mW) | 5260 ~ 5320 MHz: 137.09 5500 ~ 5720 MHz: 137.40 |
| DFS Mode | Slave without radar detection |
| Antenna Information | Refer to 5.1.1 |
| Accessory Device | Refer to 4.4 |

3.3 Noise Generating and Noise Suppressing Parts

Refer to the Circuit Diagram.

3.4 Submitted Documents

- Circuit Diagram
- Instruction Manual
- Rating Label
- Technical Description

4. Test Set-up and Operation Modes

4.1 Principle of Configuration Selection

The test modes were adapted accordingly in reference to the instructions for use.

During testing, Channel and Power Controlling Software provided by the customer was used to control the operating channel as well as the output power level. The RF output power selection is for the setting of RF output expected by the customer and is going to be fixed on the firmware of the final end product.

Table for Parameters of Test Software Setting

| 802.11a | | 802.11n HT20 802.11ac VHT20 | | 802.11n HT40 802.11ac VHT40 | | 802.11ac VHT80 | |
|---------|---------------|--------------------------------|---------------|--------------------------------|---------------|----------------|---------------|
| Channel | Power Setting | Channel | Power Setting | Channel | Power Setting | Channel | Power Setting |
| 36 | 62 | 36 | 60 | 38 | 49 | 42 | 48 |
| 40 | 61 | 40 | 60 | 46 | 59 | 58 | 53 |
| 48 | 58 | 48 | 58 | 54 | 57 | 106 | 54 |
| 52 | 58 | 52 | 57 | 62 | 57 | 122 | 59 |
| 60 | 58 | 60 | 57 | 102 | 56 | 155 | 61 |
| 64 | 58 | 64 | 57 | 110 | 63 | | |
| 100 | 62 | 100 | 62 | 134 | 57 | | |
| 116 | 63 | 116 | 63 | 151 | 63 | | |
| 140 | 54 | 140 | 50 | 159 | 63 | | |
| 149 | 63 | 149 | 63 | | | | |
| 157 | 63 | 157 | 63 | | | | |
| 165 | 63 | 165 | 63 | | | | |

4.2 Carrier Frequency and Channel

| Band | Channel | Frequency (MHz) | 802.11a 802.11n HT20 802.11ac VHT20 | 802.11n HT40 802.11ac VHT40 | 802.11ac VHT80 |
|----------------------|---------|-----------------|---|--------------------------------|----------------|
| U-NII-1 (Band 1) | 36 | 5180 | V | | |
| | 38 | 5190 | | V | |
| | 40 | 5200 | V | | |
| | 42 | 5210 | | | V |
| | 44 | 5220 | V | | |
| | 46 | 5230 | | V | |
| | 48 | 5240 | V | | |
| U-NII-2A (Band 2) | 52 | 5260 | V | | |
| | 54 | 5270 | | V | |
| | 56 | 5280 | V | | |
| | 58 | 5290 | | | V |
| | 60 | 5300 | V | | |
| | 62 | 5310 | | V | |
| | 64 | 5320 | V | | |
| U-NII-2C (Band 3) | 100 | 5500 | V | | |
| | 102 | 5510 | | V | |
| | 104 | 5520 | V | | |
| | 106 | 5530 | | | V |
| | 108 | 5540 | V | | |
| | 110 | 5550 | | V | |
| | 112 | 5560 | V | | |
| | 116 | 5580 | V | | |
| | 118 | 5590 | | V | |
| | 120 | 5600 | V | | |
| | 122 | 5610 | | | V |
| | 124 | 5620 | V | | |
| | 126 | 5630 | | V | |
| | 128 | 5640 | V | | |
| | 132 | 5660 | V | | |
| U-NII-3 (Band 4) | 134 | 5670 | | V | |
| | 136 | 5680 | V | | |
| | 140 | 5700 | V | | |
| | 149 | 5745 | V | | |
| | 151 | 5755 | | V | |
| | 153 | 5765 | V | | |
| | 155 | 5775 | | | V |
| 157 | 5785 | V | | | |
| 159 | 5795 | | V | | |
| 161 | 5805 | V | | | |
| 165 | 5825 | V | | | |

4.3 Test Operation and Test Software

Setup for testing: Test samples are provided with UART interface which makes it possible to control them through a test software installed on a notebook computer.

This software was running on the laptop computer connected to the EUT. It was used to enable the operation modes listed as below.

| | |
|---------------|-----------------|
| Test Software | rtwpriv command |
|---------------|-----------------|

The samples were used as follows:

A003457889-002, 014

A003457889-015

Full test was applied on all test modes, but only worst case was shown.

| EUT Configure Mode | Applicable To | | | Mains Conducted Emission | Description |
|--------------------|------------------------------------|---|---|--------------------------|-------------|
| | Antenna Port Conducted Measurement | Radiated Spurious Emissions above 1 GHz | Radiated Spurious Emissions below 1 GHz | | |
| - | √ | √ | √ | √ | - |

Note:

1. The EUT had been pre-tested on the positioned of each 3 axis. The worst case was found when position on Y-plane.
2. "-" means no effect.

Antenna Port Conducted Measurement

Pre-Scan full test was applied on all test modes, but only worst case was shown.

Following channel(s) was (were) selected for the final test as listed below.

| EUT Configure Mode | Mode | Frequency (MHz) | Available Channel | Tested Channel | Date Rate (Mbps) |
|--------------------|---------------------------|-----------------|-------------------|----------------|------------------|
| - | 802.11a | 5180-5240 | 36 to 48 | 36, 40, 48 | 6.0 |
| - | | 5260-5320 | 52 to 64 | 52, 60, 64 | |
| - | | 5500-5700 | 100 to 140 | 100, 116, 140 | |
| - | | 5745-5825 | 149 to 165 | 149, 157, 165 | |
| - | 802.11n HT20 (Power only) | 5180-5240 | 36 to 48 | 36, 40, 48 | MCS0 |
| - | | 5260-5320 | 52 to 64 | 52, 60, 64 | |
| - | | 5500-5700 | 100 to 140 | 100, 116, 140 | |
| - | | 5745-5825 | 149 to 165 | 149, 157, 165 | |
| - | 802.11n HT40 (Power only) | 5180-5240 | 38 to 46 | 38, 46 | MCS0 |
| - | | 5260-5320 | 54 to 62 | 54, 62 | |
| - | | 5500-5700 | 102 to 134 | 102, 110, 134 | |
| - | | 5745-5825 | 151 to 159 | 151, 159 | |
| - | 802.11ac VHT20 | 5180-5240 | 36 to 48 | 36, 40, 48 | NSS1 MCS0 |
| - | | 5260-5320 | 52 to 64 | 52, 60, 64 | |
| - | | 5500-5700 | 100 to 140 | 100, 116, 140 | |
| - | | 5745-5825 | 149 to 165 | 149, 157, 165 | |
| - | 802.11ac VHT40 | 5180-5240 | 38 to 46 | 38, 46 | NSS1 MCS0 |
| - | | 5260-5320 | 54 to 62 | 54, 62 | |
| - | | 5500-5700 | 102 to 134 | 102, 110, 134 | |
| - | | 5745-5825 | 151 to 159 | 151, 159 | |
| - | 802.11ac VHT80 | 5180-5240 | 42 | 42 | NSS1 MCS0 |
| - | | 5260-5320 | 58 | 58 | |
| - | | 5500-5700 | 100 to 140 | 106, 122 | |
| - | | 5745-5825 | 155 | 155 | |

Radiated Spurious Emissions (Above 1 GHz)

- Pre-Scan full test was applied on all test modes, but only worst case was shown.
 Following channel(s) was (were) selected for the final test as listed below.

| EUT Configure Mode | Mode | Frequency (MHz) | Available Channel | Tested Channel | Date Rate (Mbps) |
|--------------------|----------------|-----------------|-------------------|----------------|------------------|
| - | 802.11a | 5180-5240 | 36 to 48 | 36, 40, 48 | 6.0 |
| - | | 5260-5320 | 52 to 64 | 52, 60, 64 | |
| - | | 5500-5700 | 100 to 140 | 100, 116, 140 | |
| - | | 5745-5825 | 149 to 165 | 149, 157, 165 | |
| - | 802.11ac VHT20 | 5180-5240 | 36 to 48 | 36, 40, 48 | NSS1 MCS0 |
| - | | 5260-5320 | 52 to 64 | 52, 60, 64 | |
| - | | 5500-5700 | 100 to 140 | 100, 116, 140 | |
| - | | 5745-5825 | 149 to 165 | 149, 157, 165 | |
| - | 802.11ac VHT40 | 5180-5240 | 38 to 46 | 38, 46 | NSS1 MCS0 |
| - | | 5260-5320 | 54 to 62 | 54, 62 | |
| - | | 5500-5700 | 102 to 134 | 102, 110, 134 | |
| - | | 5745-5825 | 151 to 159 | 151, 159 | |
| - | 802.11ac VHT80 | 5180-5240 | 42 | 42 | MCS0 |
| - | | 5260-5320 | 58 | 58 | |
| - | | 5500-5700 | 100 to 140 | 106, 122 | |
| - | | 5745-5825 | 155 | 155 | |

Radiated Spurious Emissions (Below 1 GHz)

- Pre-Scan full test was applied on all test modes, but only worst case was shown.
 Following channel(s) was (were) selected for the final test as listed below.

| EUT Configure Mode | Mode | Frequency (MHz) | Available Channel | Tested Channel | Date Rate (Mbps) |
|--------------------|---------|-----------------|-------------------|----------------|------------------|
| - | 802.11a | 5180-5240 | 36 to 48 | 40 | 6.0 |

Mains Conducted Emission Test

- Pre-Scan full test was applied on all test modes, but only worst case was shown.
 Following channel(s) was (were) selected for the final test as listed below.

| EUT Configure Mode | Mode | Frequency (MHz) | Available Channel | Tested Channel | Date Rate (Mbps) |
|--------------------|---------|-----------------|-------------------|----------------|------------------|
| - | 802.11a | 5180-5240 | 36 to 48 | 40 | 6.0 |

Test Condition

| Test Item | Ambient Temperature | Relative Humidity | Tested by |
|---|---------------------|-------------------|------------------------|
| Conducted Measurement | 18-23 .7°C | 51-57% | Andy Chen & Blake Wang |
| Radiated Spurious Emissions above 1 GHz | 23.9-24.8 °C | 53-54 % | Chuan Chu |
| Radiated Spurious Emissions below 1 GHz | 23.9-24.8 °C | 53-54 % | Chuan Chu |
| Mains Conducted Emission | 21.1-24.9 °C | 51.7-54.9 % | Roger Liao |

4.4 Special Accessories and Auxiliary Equipment

The product has been tested together with the following additional accessories:

Accessory of EUT

None.

Support Unit

| No | Description | Brand | Model | S/N | Shielded | Ferrite Core (Qty) | Length (cm) | Remark |
|-----------------------|-------------|----------|------------------|---------------|----------|--------------------|-------------|--------|
| Radiated Test | | | | | | | | |
| A | Adapter | ULLPOWER | ICP06C-050-1000B | - | - | - | - | -- |
| B | USB Cable | DEXATEK | CP2102 | - | - | - | 220 | -- |
| 1 | Notebook | HP | 15s-du0007TX | CND93662WV | - | - | - | NB-07 |
| 2 | UART | TUV | NA | - | - | - | - | -- |
| Conducted Test | | | | | | | | |
| - | Notebook | HP | TPN-C139 | CND93662WT | - | - | - | -- |
| DFS Test | | | | | | | | |
| - | Notebook | HP | TPN-C139 | CND93662WT | - | - | - | NB-07 |
| - | UART | JIN HUA | CP2102 | - | - | - | - | -- |
| - | AP | NetGear | R7800 | 4H75745800509 | - | - | - | -- |

4.5 Test Setup Diagram

<Radiated Spurious Emissions mode>

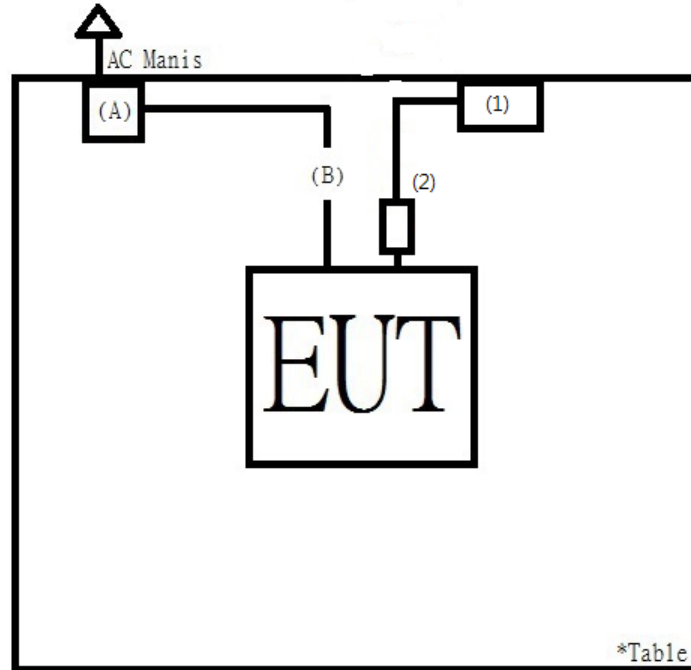

<Mains Conducted Emission mode>

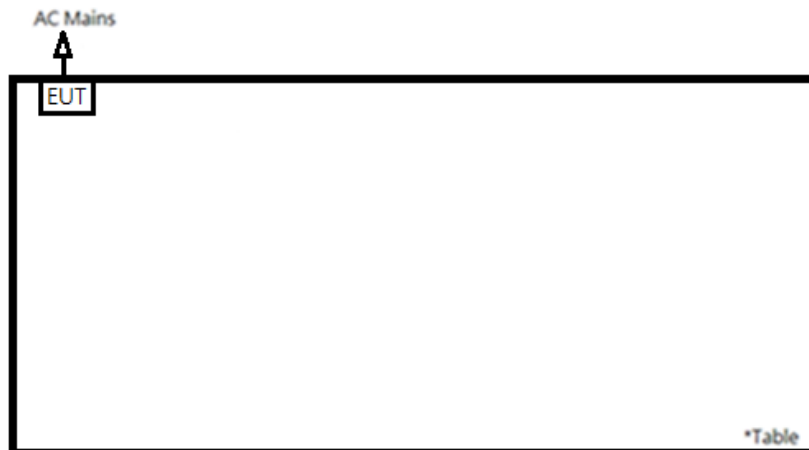

4.6 Duty Cycle of Test Signal

| Mode | On + Off Time (ms) | On Time (ms) | Duty Cycle (%) | Duty Factor (dB) |
|----------------|--------------------|--------------|----------------|------------------|
| 802.11a | 2.235 | 2.07 | 92.62 | 0.33 |
| 802.11n HT20 | 2.08 | 1.925 | 92.55 | 0.34 |
| 802.11n HT40 | 1.072 | 0.944 | 88.06 | 0.55 |
| 802.11ac VHT20 | 2.025 | 1.935 | 95.56 | 0.20 |
| 802.11ac VHT40 | 1.036 | 0.952 | 91.89 | 0.37 |
| 802.11ac VHT80 | 0.704 | 0.46 | 65.34 | 1.85 |

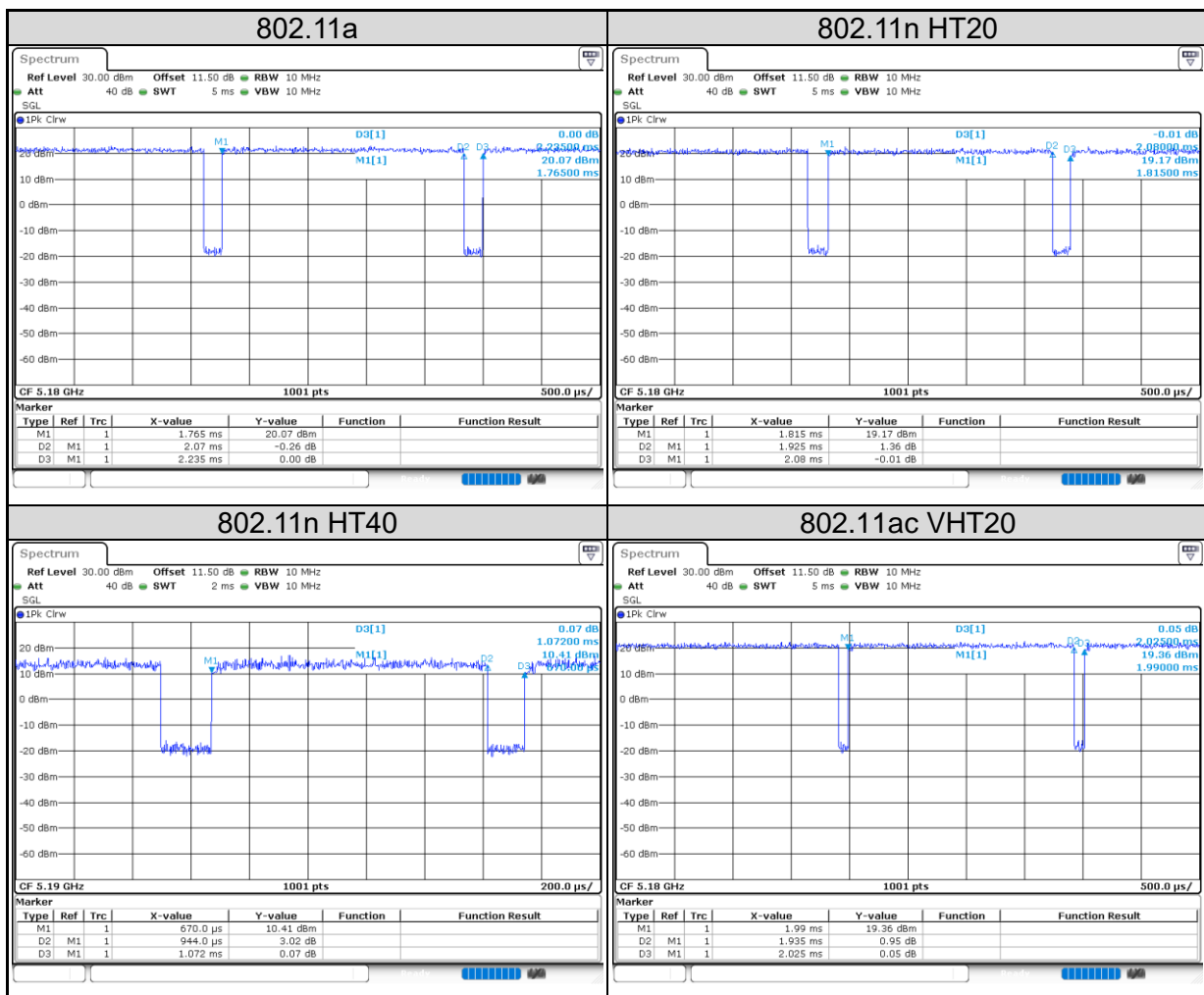

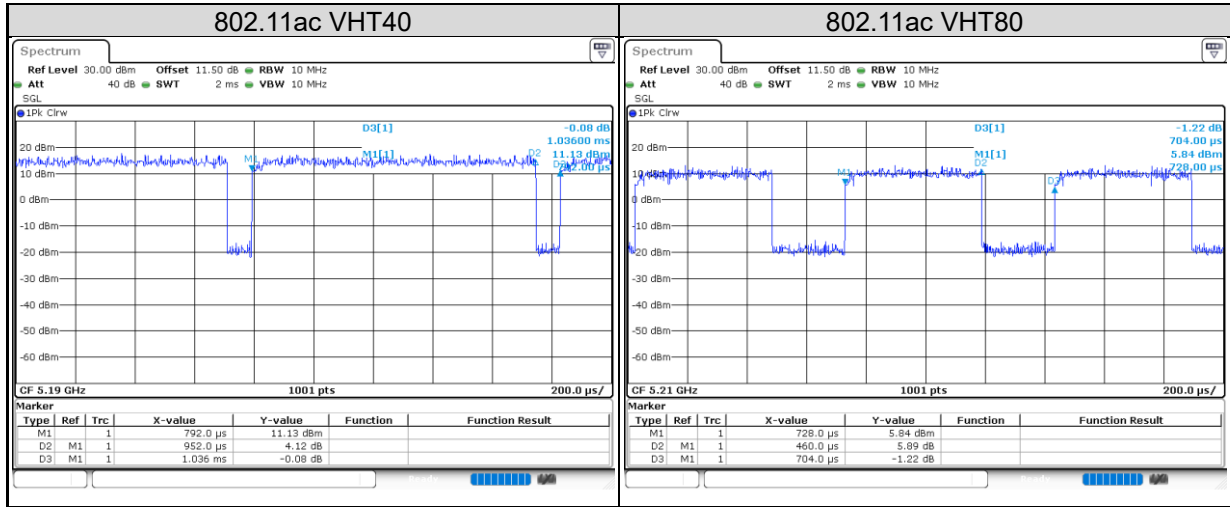

5. Test Results

5.1 Transmitter Requirement & Test Suites

5.1.1 Antenna Requirement

Requirement Use of approved antennas only

According to the manufacturer declaration, the EUT's antenna specifications are described as below. The antenna is used with no possibility of replacement with a non-approved antenna by the end-user. Therefore, the EUT is considered to comply with this provision.

PCB antenna with 3.15 dBi gain (5180 ~ 5240 MHz)
PCB antenna with 3.42 dBi gain (5260 ~ 5320 MHz)
PCB antenna with 3.42 dBi gain (5500 ~ 5700 MHz)
PCB antenna with 3.04 dBi gain (5745 ~ 5825 MHz)

Refer to EUT photo for details.

5.1.2 Maximum Conducted Output Power

Limit

| Operation Band | EUT Category | Limit |
|----------------|-----------------------------------|---|
| U-NII-1 | Outdoor Access Point | 1 Watt (30 dBm) (Max. e.i.r.p \leq 125 mW (21 dBm) at any elevation angle above 30 degrees as measured from the horizon) |
| | Fixed point-to-point Access Point | 1 Watt (30 dBm) |
| | Indoor Access Point | 1 Watt (30 dBm) |
| | Mobile and Portable client device | 250 mW (24 dBm) |
| U-NII-2A | --- | 250 mW (24 dBm) or 11 dBm + 10 log B* |
| U-NII-2C | --- | 250 mW (24 dBm) or 11 dBm + 10 log B* |
| U-NII-3 | --- | 1 Watt (30 dBm) |

Note: B* is the 26 dB emission bandwidth in megahertz

Kind of Test Site Shielded room

Test Setup



Test Instruments

| Kind of Equipment | Manufacturer | Type | S/N | Calibration Date | Calibration Due Date | Test Date | |
|-------------------|--------------|------------------|-------------|------------------|----------------------|-----------|-----------|
| | | | | | | From | Until |
| Power Meter | Anritsu | ML2495A | 1901008 | 2022/3/15 | 2023/3/14 | 2023/5/22 | 2023/5/25 |
| Power Sensor | Power Meter | MA2411B | 1725269 | 2022/3/15 | 2023/3/14 | 2023/5/22 | 2023/5/25 |
| Thermal Chamber | Giant Force | GHT-150-40-CP-SD | MAA1902-011 | 2023/4/10 | 2024/4/8 | 2023/5/22 | 2023/5/25 |

Test Procedures

Method PM is used to perform output power measurement, trigger and gating function of wide band power meter is enabled to measure max output power of TX on burst and set the detector to AVERAGE. Duty factor is not added to measured value.

Test Result
<802.11a>

| Channel | Channel Frequency (MHz) | Average Output Power | | Limit (dBm) |
|---------|-------------------------|----------------------|-------|-------------|
| | | (dBm) | (mW) | |
| 36 | 5180 | 17.90 | 61.66 | 24.00 |
| 40 | 5200 | 17.96 | 62.52 | 24.00 |
| 48 | 5240 | 18.22 | 66.37 | 24.00 |
| 52 | 5260 | 17.94 | 62.23 | 24.00 |
| 60 | 5300 | 17.93 | 62.09 | 24.00 |
| 64 | 5320 | 17.91 | 61.80 | 24.00 |
| 100 | 5500 | 17.96 | 62.52 | 24.00 |
| 116 | 5580 | 17.61 | 57.68 | 24.00 |
| 140 | 5700 | 15.16 | 32.81 | 24.00 |
| 149 | 5745 | 17.69 | 58.75 | 30.00 |
| 157 | 5785 | 17.58 | 57.28 | 30.00 |
| 165 | 5825 | 17.67 | 58.48 | 30.00 |

Note:
For U-NII-2A, U-NII-2C Band:

1. $11 \text{ dBm} + 10\log(36.72) = 26.65 \text{ dBm} > 24 \text{ dBm}$.
2. $11 \text{ dBm} + 10\log(32.17) = 26.07 \text{ dBm} > 24 \text{ dBm}$.
3. $11 \text{ dBm} + 10\log(37.36) = 26.72 \text{ dBm} > 24 \text{ dBm}$.
4. $11 \text{ dBm} + 10\log(34.57) = 26.39 \text{ dBm} > 24 \text{ dBm}$.
5. $11 \text{ dBm} + 10\log(39.38) = 26.95 \text{ dBm} > 24 \text{ dBm}$.
6. $11 \text{ dBm} + 10\log(23.42) = 24.70 \text{ dBm} > 24 \text{ dBm}$.

<802.11n HT20>

| Channel | Channel Frequency (MHz) | Average Output Power | | Limit (dBm) |
|---------|-------------------------|----------------------|-------|-------------|
| | | (dBm) | (mW) | |
| 36 | 5180 | 17.71 | 59.02 | 24.00 |
| 40 | 5200 | 17.86 | 61.09 | 24.00 |
| 48 | 5240 | 16.82 | 48.08 | 24.00 |
| 52 | 5260 | 17.80 | 60.26 | 24.00 |
| 60 | 5300 | 17.71 | 59.02 | 24.00 |
| 64 | 5320 | 17.73 | 59.29 | 24.00 |
| 100 | 5500 | 17.76 | 59.70 | 24.00 |
| 116 | 5580 | 17.44 | 55.46 | 24.00 |
| 140 | 5700 | 13.33 | 21.53 | 24.00 |
| 149 | 5745 | 17.49 | 56.10 | 30.00 |
| 157 | 5785 | 17.37 | 54.58 | 30.00 |
| 165 | 5825 | 17.46 | 55.72 | 30.00 |

<802.11n HT40>

| Channel | Channel Frequency (MHz) | Average Output Power | | Limit (dBm) |
|---------|-------------------------|----------------------|-------|-------------|
| | | (dBm) | (mW) | |
| 38 | 5190 | 14.21 | 26.36 | 24.00 |
| 46 | 5230 | 17.38 | 54.70 | 24.00 |
| 54 | 5270 | 17.81 | 60.39 | 24.00 |
| 62 | 5310 | 17.84 | 60.81 | 24.00 |
| 102 | 5510 | 16.17 | 41.40 | 24.00 |
| 110 | 5550 | 17.31 | 53.83 | 24.00 |
| 134 | 5670 | 15.84 | 38.37 | 24.00 |
| 151 | 5755 | 17.24 | 52.97 | 30.00 |
| 159 | 5795 | 17.26 | 53.21 | 30.00 |

<802.11ac VHT20>

| Channel | Channel Frequency (MHz) | Average Output Power | | Limit (dBm) |
|---------|-------------------------|----------------------|-------|-------------|
| | | (dBm) | (mW) | |
| 36 | 5180 | 17.82 | 60.53 | 24.00 |
| 40 | 5200 | 17.89 | 61.52 | 24.00 |
| 48 | 5240 | 17.01 | 50.23 | 24.00 |
| 52 | 5260 | 17.88 | 61.38 | 24.00 |
| 60 | 5300 | 17.82 | 60.53 | 24.00 |
| 64 | 5320 | 17.83 | 60.67 | 24.00 |
| 100 | 5500 | 17.85 | 60.95 | 24.00 |
| 116 | 5580 | 17.56 | 57.02 | 24.00 |
| 140 | 5700 | 13.47 | 22.23 | 24.00 |
| 149 | 5745 | 17.61 | 57.68 | 30.00 |
| 157 | 5785 | 17.50 | 56.23 | 30.00 |
| 165 | 5825 | 17.58 | 57.28 | 30.00 |

Note:
For U-NII-2A, U-NII-2C Band:

1. $11 \text{ dBm} + 10\log(33.93) = 26.31 \text{ dBm} > 24 \text{ dBm}$
2. $11 \text{ dBm} + 10\log(33.45) = 26.24 \text{ dBm} > 24 \text{ dBm}$
3. $11 \text{ dBm} + 10\log(38.60) = 26.87 \text{ dBm} > 24 \text{ dBm}$
4. $11 \text{ dBm} + 10\log(38.56) = 26.86 \text{ dBm} > 24 \text{ dBm}$
5. $11 \text{ dBm} + 10\log(37.28) = 26.72 \text{ dBm} > 24 \text{ dBm}$
6. $11 \text{ dBm} + 10\log(21.94) = 24.41 \text{ dBm} > 24 \text{ dBm}$

<802.11ac VHT40>

| Channel | Channel Frequency (MHz) | Average Output Power | | Limit (dBm) |
|---------|-------------------------|----------------------|-------|-------------|
| | | (dBm) | (mW) | |
| 38 | 5190 | 14.39 | 27.48 | 24.00 |
| 46 | 5230 | 17.52 | 56.49 | 24.00 |
| 54 | 5270 | 17.93 | 62.09 | 24.00 |
| 62 | 5310 | 17.95 | 62.37 | 24.00 |
| 102 | 5510 | 16.31 | 42.76 | 24.00 |
| 110 | 5550 | 17.41 | 55.08 | 24.00 |
| 134 | 5670 | 16.07 | 40.46 | 24.00 |
| 151 | 5755 | 17.35 | 54.33 | 30.00 |
| 159 | 5795 | 17.37 | 54.58 | 30.00 |

Note:
For U-NII-2A, U-NII-2C Band:

1. $11 \text{ dBm} + 10\log(74.57) = 29.73 \text{ dBm} > 24 \text{ dBm}$
2. $11 \text{ dBm} + 10\log(74.25) = 29.71 \text{ dBm} > 24 \text{ dBm}$
3. $11 \text{ dBm} + 10\log(48.03) = 27.82 \text{ dBm} > 24 \text{ dBm}$
4. $11 \text{ dBm} + 10\log(75.40) = 29.77 \text{ dBm} > 24 \text{ dBm}$
5. $11 \text{ dBm} + 10\log(68.09) = 29.33 \text{ dBm} > 24 \text{ dBm}$

<802.11ac VHT80>

| Channel | Channel Frequency (MHz) | Average Output Power | | Limit (dBm) |
|---------|-------------------------|----------------------|-------|-------------|
| | | (dBm) | (mW) | |
| 42 | 5210 | 14.27 | 26.73 | 24.00 |
| 58 | 5290 | 16.26 | 42.27 | 24.00 |
| 106 | 5530 | 15.38 | 34.51 | 24.00 |
| 122 | 5610 | 17.71 | 59.02 | 24.00 |
| 155 | 5775 | 17.74 | 59.43 | 30.00 |

Note:
For U-NII-2A, U-NII-2C Band:

1. $11 \text{ dBm} + 10\log(102.62) = 31.11 \text{ dBm} > 24 \text{ dBm}$
2. $11 \text{ dBm} + 10\log(91.91) = 30.63 \text{ dBm} > 24 \text{ dBm}$
3. $11 \text{ dBm} + 10\log(144.82) = 32.61 \text{ dBm} > 24 \text{ dBm}$

5.1.3 Transmit Power Control (TPC)

U-NII devices operating in the 5.25-5.35 GHz band and the 5.47-5.725 GHz band shall employ a TPC mechanism. The U-NII device is required to have capability to operate at least 6 dB below the mean EIRP value of 30 dBm. A TPC mechanism is not required for systems with an e.i.r.p of less than 500 mW.

Maximum EIRP of this device is 137.09 mW which is less than 500mW, therefore it's not require TPC function.

| TPC | E.I.R.P | 15.407(h)(1) |
|-----|---------|--|
| | > 500mW | The TPC mechanism is required for system with an E.I.R.P. of above 500mW |
| V | < 500mW | - |

5.1.4 26 dB Bandwidth and 99% Occupied Bandwidth

Kind of Test Site Shielded room

Test Setup

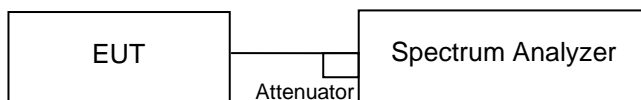

Test Instruments

| Kind of Equipment | Manufacturer | Type | S/N | Calibration Date | Calibration Due Date | Test Date | |
|-------------------|--------------|------------------|-------------|------------------|----------------------|-----------|-----------|
| | | | | | | From | Until |
| Spectrum Analyzer | R&S | FSV | 101512 | 2023/2/23 | 2024/2/22 | 2023/5/22 | 2023/5/25 |
| Thermal Chamber | Giant Force | GHT-150-40-CP-SD | MAA1902-011 | 2023/4/10 | 2024/4/8 | 2023/5/22 | 2023/5/25 |

Test Procedure

- a. Set RBW = approximately 1% of the emission bandwidth.
- b. Set the VBW > RBW.
- c. Detector = Peak.
- d. Trace mode = max hold.
- e. Measure the maximum width of the emission that is 26 dB down from the peak of the emission. Compare this with the RBW setting of the analyzer. Readjust RBW and repeat measurement as needed until the RBW/EBW ratio is approximately 1%.
- f. For 99% Bandwidth Measurement, the transmitter output was connected to the spectrum analyzer through an attenuator. The bandwidth of the fundamental frequency was measured by spectrum analyzer with resolution bandwidth in the range of 1% to 5% of the anticipated emission bandwidth, and a video bandwidth at least 3x the resolution bandwidth and set the detector to PEAK. The width of a frequency band such that, below the lower and above the upper frequency limits, the mean powers emitted are each equal to a specified percentage 0.5% of the total mean power of a given emission.

Test Results

Please refer to Appendix A.

5.1.5 6 dB Bandwidth (5725-5850MHz)

Kind of Test Site Shielded room

Test Setup

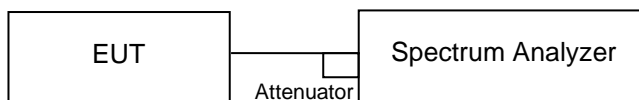

Test Instruments

| Kind of Equipment | Manufacturer | Type | S/N | Calibration Date | Calibration Due Date | Test Date | |
|-------------------|--------------|------------------|-------------|------------------|----------------------|-----------|-----------|
| | | | | | | From | Until |
| Spectrum Analyzer | R&S | FSV | 101512 | 2023/2/23 | 2024/2/22 | 2023/5/22 | 2023/5/25 |
| Thermal Chamber | Giant Force | GHT-150-40-CP-SD | MAA1902-011 | 2023/4/10 | 2024/4/8 | 2023/5/22 | 2023/5/25 |

Test Procedure

MEASUREMENT PROCEDURE REF

- a. Set resolution bandwidth (RBW) = 100 kHz
- b. Set the video bandwidth (VBW) ≥ 3 x RBW, Detector = Peak.
- c. Trace mode = max hold.
- d. Sweep = auto couple.
- e. Measure the maximum width of the emission that is constrained by the frequencies associated with the two amplitude points (upper and lower) that are attenuated by 6 dB relative to the maximum level measured in the fundamental emission.

Test Results

Please refer to Appendix A

5.1.6 Frequency Stability Measurement

Kind of Test Site Shielded room

Test Setup

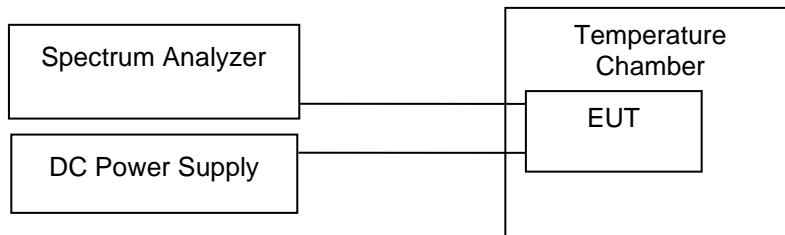

Test Instruments

| Kind of Equipment | Manufacturer | Type | S/N | Calibration Date | Calibration Due Date | Test Date | |
|-------------------|--------------|------------------|-------------|------------------|----------------------|-----------|-----------|
| | | | | | | From | Until |
| Spectrum Analyzer | R&S | FSV | 101512 | 2023/2/23 | 2024/2/22 | 2023/5/22 | 2023/5/25 |
| Thermal Chamber | Giant Force | GHT-150-40-CP-SD | MAA1902-011 | 2023/4/10 | 2024/4/8 | 2023/5/22 | 2023/5/25 |

Test Procedure

- a. To ensure emission at the band edge is maintained within the authorized band, those values shall be measured by radiation emissions at upper and lower frequency points, and finally compensated by frequency deviation as procedures below.
- b. The EUT was operated at the maximum output power, and connected to the spectrum analyzer, which is set to maximum hold function and peak detector. The peak value of the power envelope was measured and noted. The upper and lower frequency points were respectively measured relatively 10 dB lower than the measured peak value.
- c. The frequency deviation was calculated by adding the upper frequency point and the lower frequency point divided by two. Those detailed values of frequency deviation are provided in table below.

Test Results

| Frequency (MHz) | 5785 | | | |
|----------------------|-----------------------------|-------------|-------------|----------------------|
| Voltage (V) | Measurement Frequency (MHz) | | | Max. Deviation (ppm) |
| 5.5 | 5785.002675 | | | 0.462 |
| 5 | 5785.021109 | | | 3.649 |
| 4.5 | 5785.000932 | | | 0.161 |
| Temperature (°C) | Measurement Frequency (MHz) | | | |
| | 0 Minute | 2 Minute | 5 Minute | 10 Minute |
| 50 | 5785.000331 | 5785.017685 | 5785.00913 | 5785.003873 |
| 40 | 5785.002722 | 5785.005892 | 5785.000233 | 5785.018087 |
| 30 | 5785.018628 | 5785.013000 | 5785.01525 | 5785.014287 |
| 20 | 5785.020951 | 5785.015615 | 5785.005474 | 5785.007813 |
| 10 | 5785.006913 | 5785.012279 | 5785.015846 | 5785.00156 |
| 0 | 5785.019147 | 5785.006859 | 5785.018138 | 5785.016857 |
| -10 | 5785.020858 | 5785.018274 | 5785.01751 | 5785.008668 |
| -20 | 5785.015573 | 5785.008483 | 5785.007055 | 5785.002157 |
| -30 | 5785.000298 | 5785.017179 | 5785.009144 | 5785.019397 |
| Max. Deviation (ppm) | 3.938 | 3.435 | 3.409 | 3.646 |

5.1.7 Power Spectral Density

Limit

For the 5.15~5.25GHz Bands:

For mobile and portable client devices in the 5.15~5.25GHz band, the Maximum Power spectral density shall not exceed 11dBm/MHz. For an indoor access point operating in the band 5.15~5.25GHz, the maximum power spectral density shall not exceed 17dBm/MHz.

For the 5.25~5.35GHz and 5.47~5.725GHz Bands:

The maximum power spectral density shall not exceed 11dBm/MHz.

For the 5.745~5.85GHz Bands:

The maximum power spectral density shall not exceed 30dBm/500kHz.

Kind of Test Site Shielded room

Test Setup

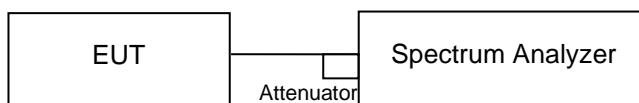

Test Instruments

| Kind of Equipment | Manufacturer | Type | S/N | Calibration Date | Calibration Due Date | Test Date | |
|-------------------|--------------|------------------|-------------|------------------|----------------------|-----------|-----------|
| | | | | | | From | Until |
| Spectrum Analyzer | R&S | FSV | 101512 | 2023/2/23 | 2024/2/22 | 2023/5/22 | 2023/5/25 |
| Thermal Chamber | Giant Force | GHT-150-40-CP-SD | MAA1902-011 | 2023/4/10 | 2024/4/8 | 2023/5/22 | 2023/5/25 |

Test Procedure**For U-NII-1, U-NII-2A, U-NII-2C band:**

Using method SA-2

1. Set span to encompass the entire emission bandwidth (EBW) of the signal.
2. Set RBW = 1 MHz, Set VBW \geq 3 MHz, Detector = RMS
3. Sweep time = auto, trigger set to "free run".
4. Trace average at least 100 traces in power averaging mode.
5. Record the max value and add 10 log (1/duty cycle)

※For U-NII-3:

1. Set span to encompass the entire emission bandwidth (EBW) of the signal.
2. Set RBW = 500 kHz, Set VBW \geq 3 RBW, Detector = RMS
3. Use the peak marker function to determine the maximum power level in any 500 kHz band segment within the fundamental EBW.
4. Sweep time = auto, trigger set to "free run".
5. Trace average at least 100 traces in power averaging mode.
6. Record the max value and add 10 log (1/duty cycle)

For MIMO mode, calculation method follows FCC KDB 662911 Method 2) a) of power density measurement using for calculating total power density. Total power density is summing entire spectra across corresponding frequency bins on the various outputs by computer.

Test Results

Please refer to Appendix A

5.1.8 Radiated Spurious Emissions

Limit

Radiated emissions which fall in the restricted bands, as defined in §15.205(a), must comply with the radiated emission limits specified in §15.209(a).

Emissions radiated outside the restricted and authorized frequency bands must either comply with the radiated emission limits specified for the restricted bands or in §15.407(b).

Kind of Test Site 3m Semi-Anechoic Chamber

Test Setup

<Radiated Emissions below 30 MHz>

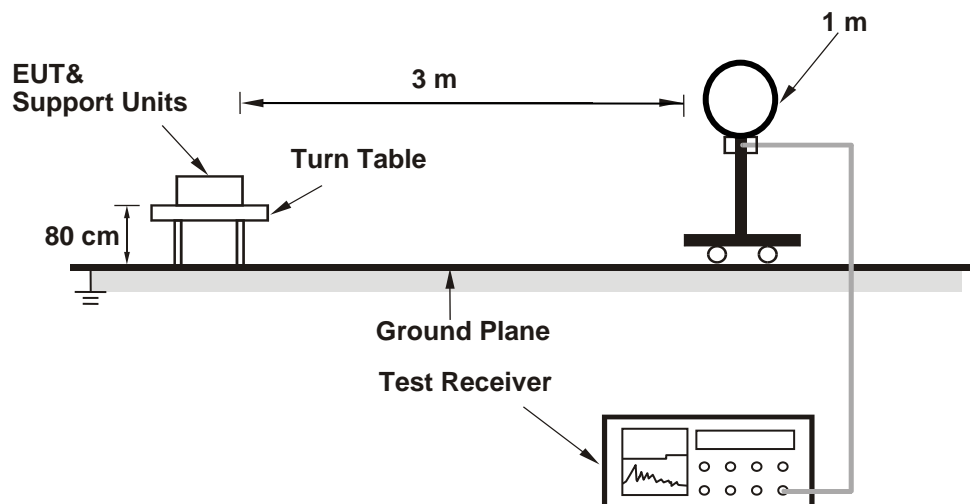

<Radiated Emissions 30 MHz to 1 GHz>

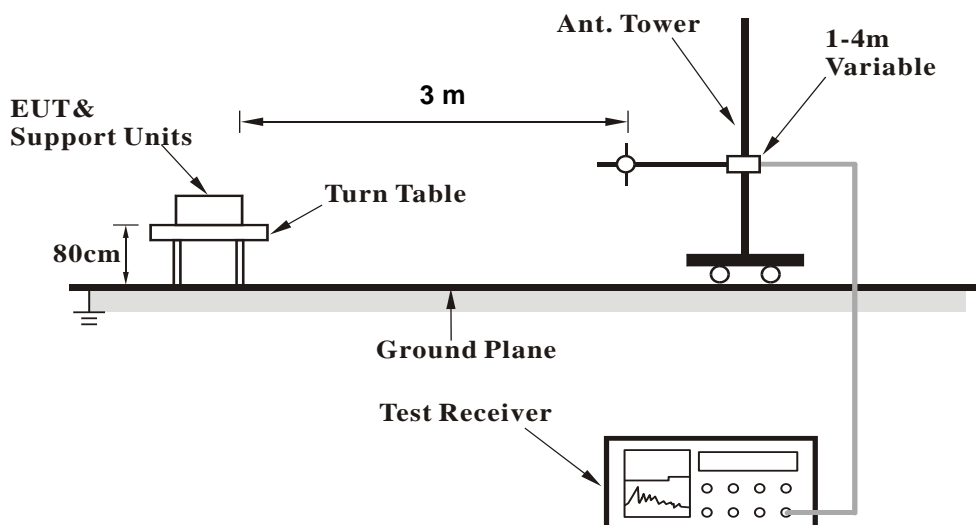

<Radiated Emissions above 1 GHz>

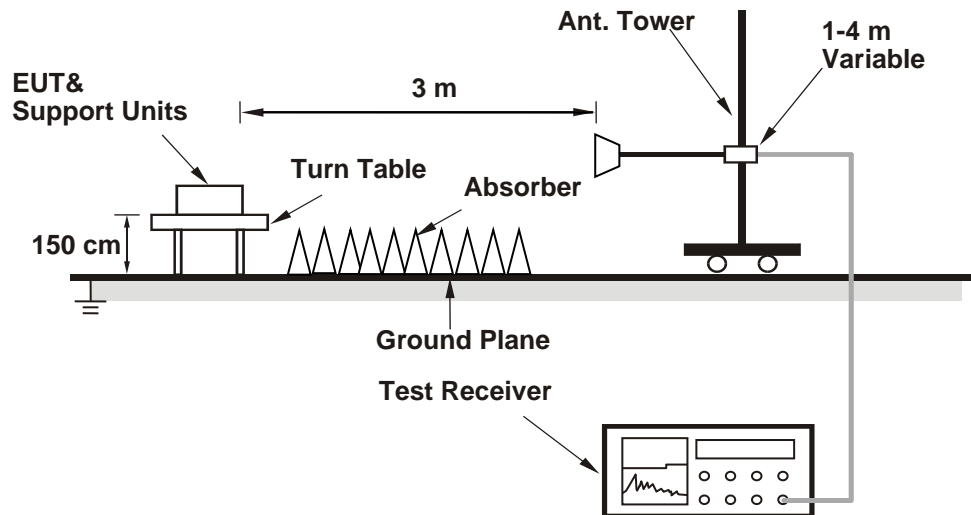

For the actual test configuration, please refer to the attached file (Test Setup Photo).

Test Instruments

2023/5/13 ~ 2023/5/18

| Kind of Equipment | Manufacturer | Type | S/N | Calibration Date | Calibration Due Date |
|--------------------|--------------|------------------------|-------------|------------------|----------------------|
| Above 1 GHz | | | | | |
| Signal Analyzer | R&S | FSV40 | 101508 | 2023/4/20 | 2024/4/18 |
| Horn Antenna | ETS-Lindgren | 3117 | 00218929 | 2022/12/8 | 2023/12/7 |
| HF-AMP + AC source | EMCI | EMC051845SE | 980633 | 2023/2/22 | 2024/2/21 |
| HF-AMP + AC source | EMCI | EMC184045SE | 980657 | 2023/2/16 | 2024/2/15 |
| Horn Antenna | SCHWARZBECK | BBHA 9170 | 00218930 | 2022/12/8 | 2023/12/7 |
| Test Software | Audix E3 | 15914a_20191106 tuv | PK-001087 | N/A | N/A |
| 30 MHz ~ 1 GHz | | | | | |
| Receiver | R&S | ESR7 | 102109 | 2023/2/24 | 2024/2/23 |
| Bilog Antenna | SCHWARZBECK | VULB-9168 | 00951 | 2023/3/31 | 2024/3/29 |
| LF-AMP | Agilent | 8447D | 2944A107722 | 2023/3/22 | 2024/3/20 |
| Test Software | Audix E3 | 15914a_20191106 tuv | PK-001087 | N/A | N/A |
| Below 30 MHz | | | | | |
| Receiver | R&S | ESR7 | 102109 | 2023/2/24 | 2024/2/23 |
| Loop Antenna | SCHWARZBECK | FMZB 1519B | 00215 | 2023/1/4 | 2024/1/3 |
| Test Software | Audix E3 | 15914a_20191106 tuv | PK-001087 | N/A | N/A |

Test Procedures**For Radiated Emissions below 30 MHz**

- a. The EUT was placed on the top of a rotating table 0.8 meters above the ground at a 3 meter chamber room. The table was rotated 360 degrees to determine the position of the highest radiation.
- b. The EUT was set 3 meters away from the interference-receiving antenna, which was mounted on the top of a variable-height antenna tower.
- c. Parallel (OPEN), perpendicular (CLOSE), and ground-parallel (GROUND) orientations of the antenna are set to make the measurement.
- d. For each suspected emission, the EUT was arranged to its worst case and the rotatable table was turned from 0 degrees to 360 degrees to find the maximum reading.
- e. The test-receiver system was set to Quasi-Peak Detect Function and Specified Bandwidth with Maximum Hold Mode.
- f. The test-receiver system was set to peak and average detected function and specified bandwidth with maximum hold mode when the test frequency are 9-90 kHz, 110-490 kHz and above 1 GHz. If the peak reading value also meets average limit, measurement with the average detector is unnecessary.

Note:

1. The resolution bandwidth and video bandwidth of test receiver/spectrum analyzer is 9 kHz at frequency below 30 MHz.
2. All modes of operation were investigated and the worst-case emissions are reported.

For Radiated Emissions above 30 MHz

- a. The EUT was placed on the top of a rotating table 0.8 meters (for 30 MHz ~ 1 GHz) / 1.5 meters (for above 1 GHz) above the ground at 3 meter chamber room for test. The table was rotated 360 degrees to determine the position of the highest radiation.
- b. The EUT was set 3 meters away from the interference-receiving antenna, which was mounted on the top of a variable-height antenna tower.
- c. The height of antenna is varied from one meter to four meters above the ground to determine the maximum value of the field strength. Both horizontal and vertical polarizations of the antenna are set to make the measurement.
- d. For each suspected emission, the EUT was arranged to its worst case and then the antenna was tuned to heights from 1 meter to 4 meters and the rotatable table was turned from 0 degrees to 360 degrees to find the maximum reading.
- e. The test-receiver system was set to quasi-peak detect function and specified bandwidth with maximum hold mode when the test frequency is below 1 GHz.
- f. The test-receiver system was set to peak and average detected function and specified bandwidth with maximum hold mode when the test frequency is above 1 GHz. If the peak reading value also meets average limit, measurement with the average detector is unnecessary.

Note:

1. The resolution bandwidth and video bandwidth of test receiver/spectrum analyzer is 120 kHz for Quasi-peak detection (QP) or Peak detection (PK) at frequency below 1 GHz.
2. The resolution bandwidth of test receiver/spectrum analyzer is 1 MHz and the video bandwidth is 3 MHz for Peak detection (PK) at frequency above 1 GHz.
3. The resolution bandwidth of test receiver/spectrum analyzer is 1 MHz and the video bandwidth is $\geq 1/T$ (Duty cycle < 98 %) or 10 Hz (Duty cycle ≥ 98 %) for Average detection (AV) at frequency above 1 GHz.
4. All modes of operation were investigated and the worst-case emissions are reported.

5. The Radiated Emissions testing was performed in the X(E1), Y(H) and Z(E2) axis orientation. The worst-case Axis orientation is recorded in this test report.
6. The emission levels of other frequencies (including the 10th harmonic of the highest fundamental frequency) are very lower than the limit and are not shown in the test report.

Test Results

Factor (dB/m) = Antenna Factor (dB/m) + Cable Loss (dB)

Level (dBuV/m) = Reading (dBuV) + Factor (dB/m)

Please refer to Appendix B.

5.1.9 Dynamic Frequency Selection

Limit

<DFS Detection Thresholds for Master Devices and Client Devices with Radar Detection>

| Maximum Transmit Power | Value (See Notes 1, 2, and 3) |
|---|----------------------------------|
| EIRP \geq 200 milliwatt | -64 dBm |
| EIRP < 200 milliwatt and power spectral density < 10 dBm/MHz | -62 dBm |
| EIRP < 200 milliwatt that do not meet the power spectral density requirement | -64 dBm |

Note 1: This is the level at the input of the receiver assuming a 0 dBi receive antenna.
 Note 2: Throughout these test procedures an additional 1 dB has been added to the amplitude of the test transmission waveforms to account for variations in measurement equipment. This will ensure that the test signal is at or above the detection threshold level to trigger a DFS response.
 Note 3: EIRP is based on the highest antenna gain. For MIMO devices refer to KDB Publication 662911 D01.

<DFS Response Requirement Values>

| Parameter | Value |
|--|---|
| <i>Non-occupancy period</i> | Minimum 30 minutes |
| <i>Channel Availability Check Time</i> | 60 seconds |
| <i>Channel Move Time</i> | 10 seconds See Note 1. |
| <i>Channel Closing Transmission Time</i> | 200 milliseconds + an aggregate of 60 milliseconds over remaining 10 second period. See Notes 1 and 2. |
| <i>U-NII Detection Bandwidth</i> | Minimum 100% of the U-NII 99% transmission power bandwidth. See Note 3. |

Note 1: *Channel Move Time* and the *Channel Closing Transmission Time* should be performed with Radar Type 0. The measurement timing begins at the end of the Radar Type 0 burst.
 Note 2: The *Channel Closing Transmission Time* is comprised of 200 milliseconds starting at the beginning of the *Channel Move Time* plus any additional intermittent control signals required to facilitate a *Channel* move (an aggregate of 60 milliseconds) during the remainder of the 10 second period. The aggregate duration of control signals will not count quiet periods in between transmissions.
 Note 3: During the *U-NII Detection Bandwidth* detection test, radar type 0 should be used. For each frequency step the minimum percentage of detection is 90 percent. Measurements are performed with no data traffic.

Kind of Test Site Shielded room

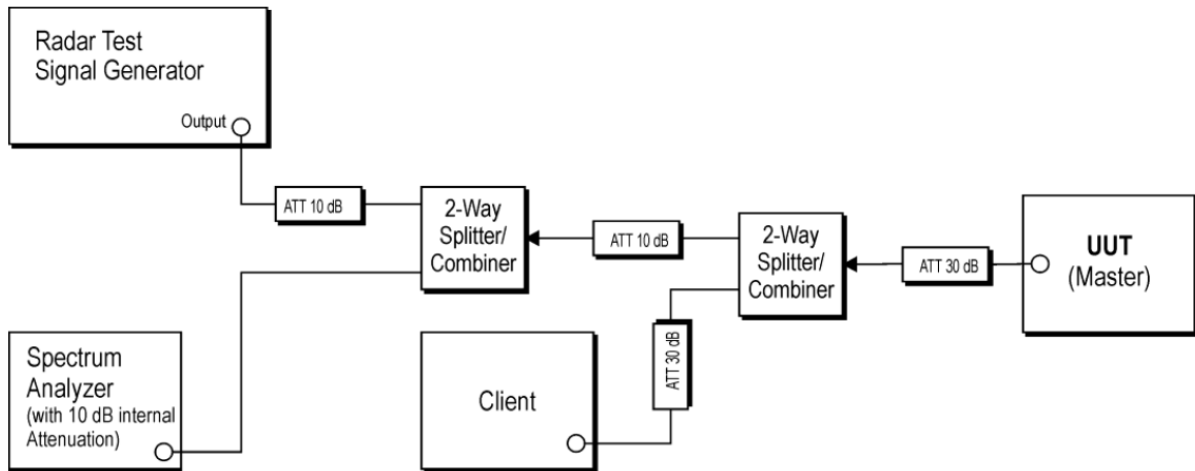
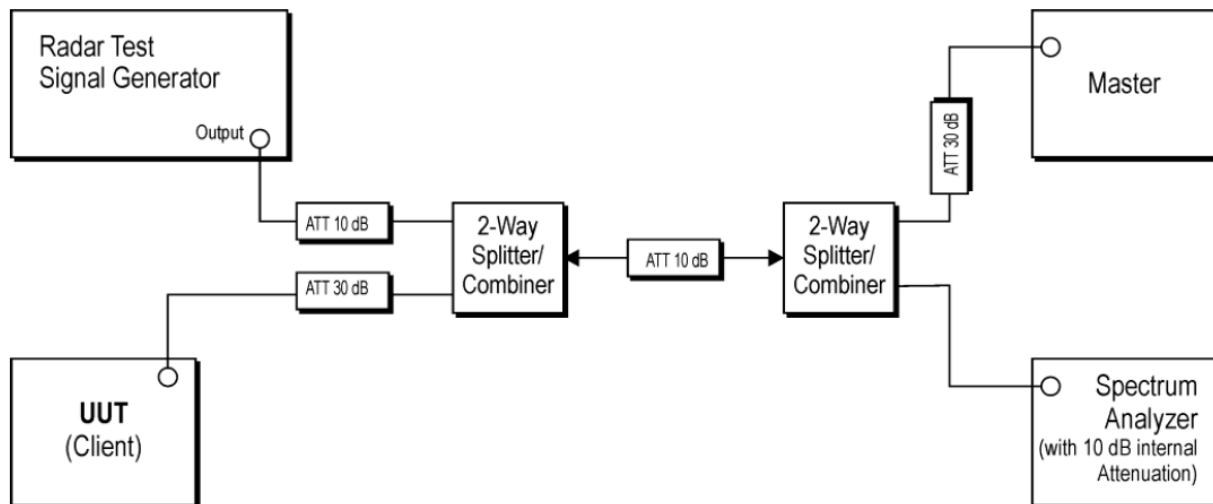
Test Setup
<Setup for Master with injection at the Master>

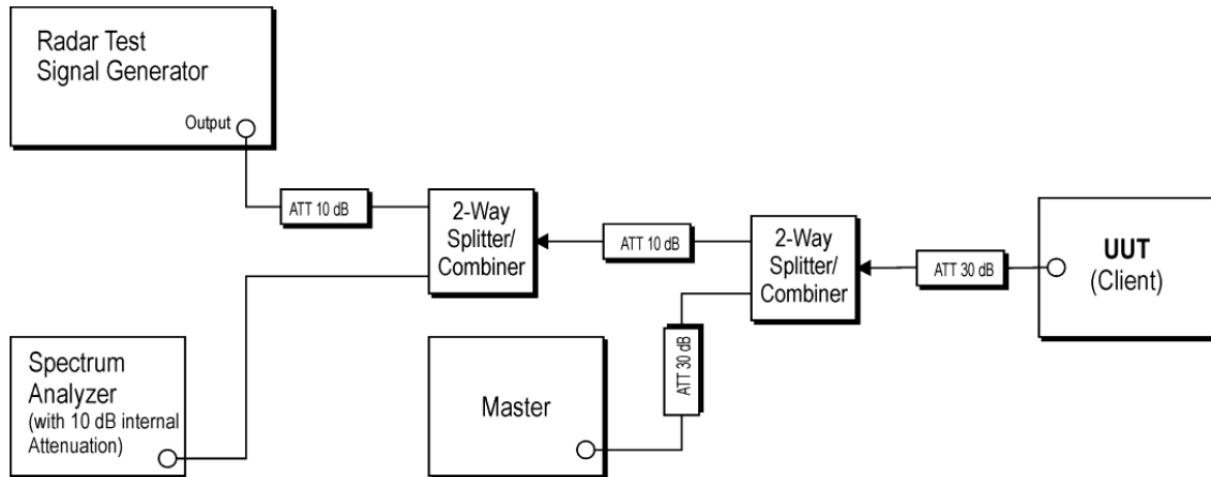
<Setup for Client with injection at the Master>

<Setup for Client with injection at the Client>

Test Instruments

| Kind of Equipment | Manufacturer | Type | S/N | Calibration Date | Calibration Due Date | Test Date | |
|-----------------------------|--------------|--------|------------|------------------|----------------------|-----------|-----------|
| | | | | | | From | Until |
| Spectrum Analyzer | Agilent | N9000B | MY62361339 | 2023/2/11 | 2024/2/10 | 2023/5/26 | 2023/5/29 |
| MXG Vector Signal Generator | Agilent | N5182B | MY53050524 | 2023/3/17 | 2024/3/15 | 2023/5/26 | 2023/5/29 |

Requirement

| Requirement | Operational Mode | |
|--|--|--------------------------------|
| | Master Device or Client with Radar Detection | Client Without Radar Detection |
| <i>DFS Detection Threshold</i> | Yes | Not required |
| <i>Channel Closing Transmission Time</i> | Yes | Yes |
| <i>Channel Move Time</i> | Yes | Yes |
| <i>U-NII Detection Bandwidth</i> | Yes | Not required |

| Additional requirements for devices with multiple bandwidth modes | Master Device or Client with Radar Detection | Client Without Radar Detection |
|--|--|--|
| <i>U-NII Detection Bandwidth and Statistical Performance Check</i> | All BW modes must be tested | Not required |
| <i>Channel Move Time and Channel Closing Transmission Time</i> | Test using widest BW mode available | Test using the widest BW mode available for the link |
| <i>All other tests</i> | Any single BW mode | Not required |

Note: Frequencies selected for statistical performance check (Section 7.8.4) should include several frequencies within the radar detection bandwidth and frequencies near the edge of the radar detection bandwidth. For 802.11 devices it is suggested to select frequencies in each of the bonded 20 MHz channels and the channel center frequency.

Test Results
<802.11ac VHT80>

Non-occupancy period

| Channel (MHz) | Limit (minute) | Result |
|---------------|----------------|--------|
| 5530 | 30 | Pass |

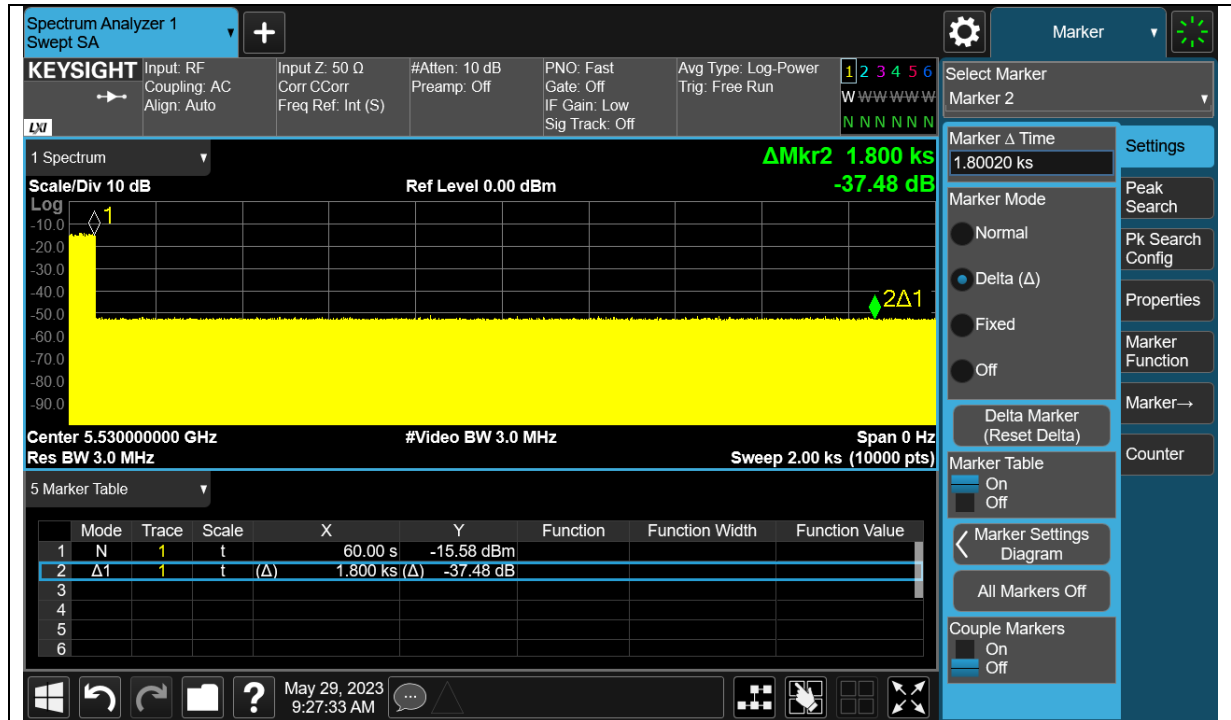

Channel Moving Time

| Channel (MHz) | Channel Move Time (s) | Limit (s) | Result |
|---------------|-----------------------|-----------|--------|
| 5530 | 0.328 | 10 | Pass |

Channel Closing Transmission Time

| Channel (MHz) | Channel Closing Transmission Time (ms) | Limit (ms) | Result |
|---------------|--|------------|--------|
| 5530 | 4 | 60 | Pass |

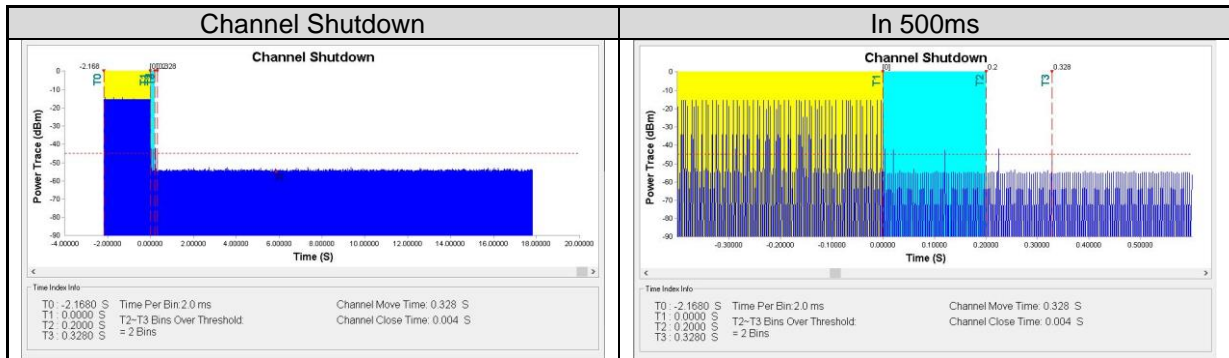
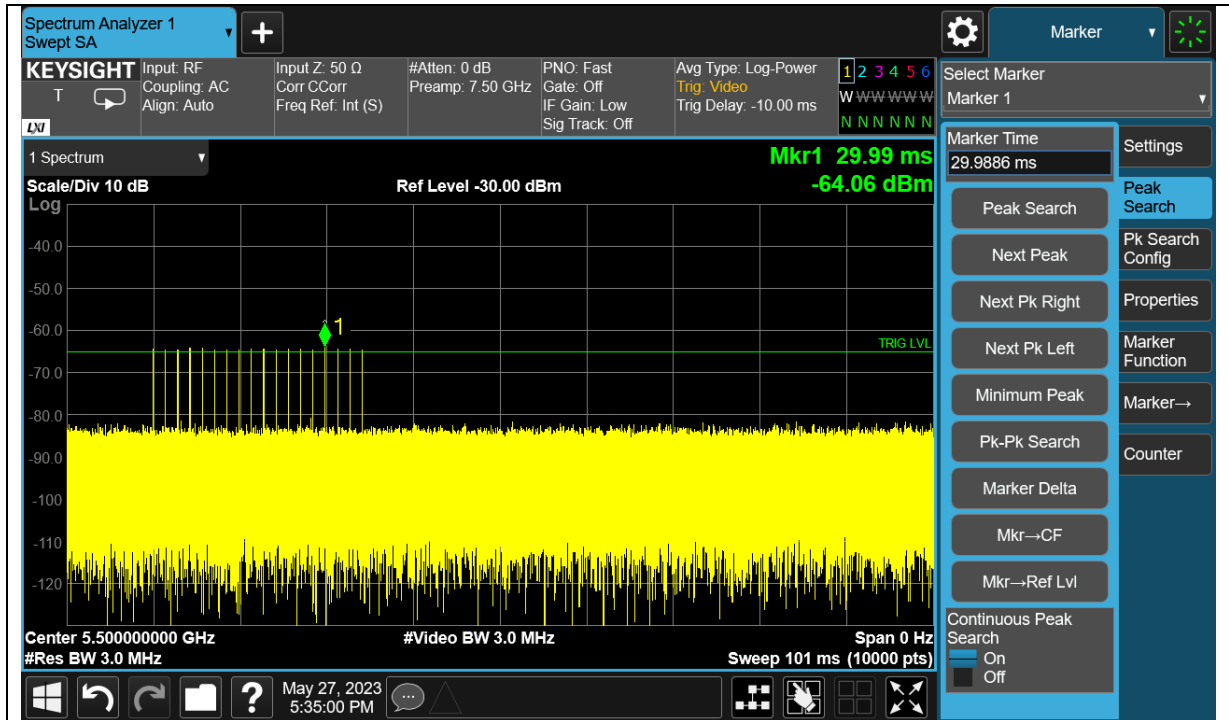
Radar Level

5.2 Mains Emission

5.2.1 Mains Conducted Emission

Limit

Mains Conducted emissions as defined in §15.207 must comply with the mains conducted emission limits.

Kind of Test Site Shielded room

Test Setup

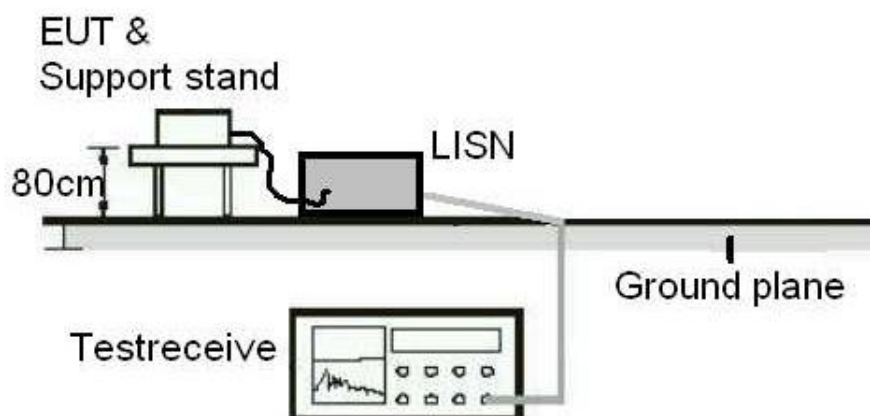

Test Instruments

Test Date: 2023/6/2

| Kind of Equipment | Manufacturer | Type | S/N | Calibration Date | Calibration Due Date |
|--------------------|-----------------|--------|--------|------------------|----------------------|
| Two-Line V-Network | Rohde & Schwarz | ENV216 | 101938 | 2022/9/22 | 2023/9/21 |
| EMI Test Receiver | R&S | ESCI | 100797 | 2022/6/19 | 2023/6/18 |

Test Procedures

- a. The EUT was placed 0.4 meters from the conducting wall of the shielded room with EUT being connected to the power mains through a line impedance stabilization network (LISN). Other support units were connected to the power mains through another LISN. The two LISNs provide 50 ohm/50 uH of coupling impedance for the measuring instrument.
- b. Both lines of the power mains connected to the EUT were checked for maximum conducted interference.
- c. The frequency range from 150 kHz to 30 MHz was searched. Emission levels under (Limit – 20 dB) was not recorded.

Note: The resolution bandwidth and video bandwidth of test receiver is 9 kHz for quasi-peak detection (QP) and average detection (AV) at frequency 0.15 MHz – 30 MHz.

Test Results

Please refer to Appendix B.