



TEST REPORT

FCC PART 15 SUBPART E 15.407

Report Reference No.: CTL2310129032-WF02

Compiled by: (position+printed name+signature)	Happy Guo (File administrators)
Tested by: (position+printed name+signature)	Jack Wang (Test Engineer)
Approved by: (position+printed name+signature)	Ivan Xie (Manager)



Product Name:	WIFI Module
Model/Type reference	ALXC28
List Model(s):	N/A
Trade Mark:	N/A
FCC ID:	SMQXC28EDAN
Applicant's name	Edan Instruments, Inc
Address of applicant	#15 Jinhui Road, Jinsha Community, Kengzi Sub-District, Pingshan District,518122 Shenzhen P.R.China
Test Firm	Shenzhen CTL Testing Technology Co., Ltd.
Address of Test Firm	Zone A, 1st Floor, Warehouse 2, Baisha Logistics Company, No. 3011 Shahe West Road, Nanshan District, Shenzhen
Test specification	
Standard.....:	47 CFR FCC Part 15 Subpart E 15.407
TRF Originator	Shenzhen CTL Testing Technology Co., Ltd.
Master TRF	Dated 2011-01
Date of receipt of test item	Oct. 12, 2023
Date of Test Date	Oct. 12, 2023- Nov. 13, 2023
Date of Issue:	Nov. 14, 2023
Result:	Pass
Shenzhen CTL Testing Technology Co., Ltd. All rights reserved.	
This publication may be reproduced in whole or in part for non-commercial purposes as long as the Shenzhen CTL Testing Technology Co., Ltd. is acknowledged as copyright owner and source of the material. Shenzhen CTL Testing Technology Co., Ltd. takes no responsibility for and will not assume liability for damages resulting from the reader's interpretation of the reproduced material due to its placement and context.	

TEST REPORT

Test Report No. :	CTL2310129032-WF02	Nov. 14, 2023
		Date of issue

Equipment under Test : WIFI Module

Sample No : CTL2310129032

Model /Type : ALXC28

Listed Models : N/A

Applicant : **Edan Instruments, Inc**

Address : #15 Jinhui Road, Jinsha Community, Kengzi
Sub-District, Pingshan District, 518122 Shenzhen
P.R.China

Manufacturer : **Edan Instruments, Inc**

Address : #15 Jinhui Road, Jinsha Community, Kengzi
Sub-District, Pingshan District, 518122 Shenzhen
P.R.China

Test result	Pass *
--------------------	---------------

* In the configuration tested, the EUT complied with the standards specified page 5.

The test results presented in this report relate only to the object tested.

This report shall not be reproduced, except in full, without the written approval of the issuing testing laboratory.

Table of Contents

Page

1. SUMMARY.....	5
1.1. TEST STANDARDS.....	5
1.2. TEST DESCRIPTION.....	5
1.3. TEST FACILITY.....	6
1.4. STATEMENT OF THE MEASUREMENT UNCERTAINTY.....	6
1.5. EUT CONFIGURATION.....	7
2. GENERAL INFORMATION.....	8
2.1. ENVIRONMENTAL CONDITIONS.....	8
2.2. GENERAL DESCRIPTION OF EUT.....	8
2.3. DESCRIPTION OF TEST MODES AND TEST FREQUENCY.....	9
2.4. EQUIPMENTS USED DURING THE TEST.....	10
2.5. RELATED SUBMITTAL(S) / GRANT (S).....	10
2.6. MODIFICATIONS.....	10
3. TEST CONDITIONS AND RESULTS.....	11
3.1. CONDUCTED EMISSIONS TEST.....	11
3.2. RADIATED EMISSIONS.....	14
3.3. MAXIMUM CONDUCTED AVERAGE OUTPUT POWER.....	26
3.4. POWER SPECTRAL DENSITY.....	27
3.5. EMISSION BANDWIDTH (26dBm BANDWIDTH).....	29
3.6. MINIMUM EMISSION BANDWIDTH (6dBm BANDWIDTH).....	30
3.7. FREQUENCY STABILITY.....	31
3.8. ANTENNA REQUIREMENT.....	32
4. TEST SETUP PHOTOS OF THE EUT.....	33
5. PHOTOS OF THE EUT.....	34

1. SUMMARY

1.1. TEST STANDARDS

The tests were performed according to following standards:

[FCC Rules Part 15 Subpart E](#)—Unlicensed National Information Infrastructure Devices

[ANSI C63.10: 2013](#): American National Standard for Testing Unlicensed Wireless Devices

[KDB789033 D02](#): General UNII Test Procedures New Rules v02r01

v01r03 and [KDB 662911 D01 Multiple Transmitter Output v02r01](#) is required to be used for this kind of FCC 15.407 UII device.

1.2. Test Description

FCC Requirement		
FCC Part 15.207	AC Power Conducted Emission	PASS
FCC Part 15.407(a)	Emission Bandwidth(26dBm Bandwidth)	PASS ^{Note1}
FCC Part 15.407(e)	Minimum Emission Bandwidth(6dBm Bandwidth)	PASS ^{Note2}
FCC Part 15.407(a)	Maximum Conducted Output Power	PASS
FCC Part 15.407(a)	Peak Power Spectral Density	PASS
FCC Part 15.407(g)	Frequency Stability	PASS
FCC Part 15.407(b)	Undesirable emission	PASS
FCC Part 15.407(b)/15.205/15.209	Radiated Emissions	PASS
FCC Part 15.407(h)	Dynamic Frequency Selection	PASS ^{Note3}
FCC Part 15.203	Antenna requirement	PASS

Note 1: Apply to U-NII 1, U-NII 2A, and U-NII 2C band.

Note 2: Apply to U-NII 3 band only.

Note 3: Test result refer to DFS report.

1.3. Test Facility

1.3.1 Address of the test laboratory

Shenzhen CTL Testing Technology Co., Ltd.
Zone A, 1st Floor, Warehouse 2, Baisha Logistics Company, No. 3011 Shahe West Road, Nanshan District, Shenzhen.

The 3m-Semi anechoic test site fulfils CISPR 16-1-4 according to ANSI C63.10 and CISPR 16-1-4:2010 SVSWR requirement for radiated emission above 1GHz.

1.3.2 Laboratory accreditation

The test facility is recognized, certified, or accredited by the following organizations:

CNAS-Lab Code: L7497

Shenzhen CTL Testing Technology Co., Ltd. has been assessed and proved to be in compliance with CNAS-CL01 Accreditation Criteria for Testing and Calibration Laboratories (identical to ISO/IEC 17025: 2017 General Requirements) for the Competence of Testing and Calibration Laboratories.

A2LA-Lab Cert. No. 4343.01

Shenzhen CTL Testing Technology Co., Ltd, EMC Laboratory has been accredited by A2LA for technical competence in the field of electrical testing, and proved to be in compliance with ISO/IEC 17025: 2017 General Requirements for the Competence of Testing and Calibration Laboratories and any additional program requirements in the identified field of testing.

IC Registration No.: 9618B

CAB identifier: CN0041

The 3m alternate test site of Shenzhen CTL Testing Technology Co., Ltd. EMC Laboratory has been registered by Innovation, Science and Economic Development Canada to test to Canadian radio equipment requirements with Registration No.: 9618B on Jan. 22, 2019.

FCC-Registration No.: 399832

Designation No.: CN1216

Shenzhen CTL Testing Technology Co., Ltd. EMC Laboratory has been registered and fully described in a report filed with the (FCC) Federal Communications Commission. The acceptance letter from the FCC is maintained in our files. Registration 399832, December 08, 2017.

1.4. Statement of the measurement uncertainty

The data and results referenced in this document are true and accurate. The reader is cautioned that there may be errors within the calibration limits of the equipment and facilities. The measurement uncertainty was calculated for all measurements listed in this test report acc. to CISPR 16 - 4 "Specification for radio disturbance and immunity measuring apparatus and methods – Part 4: Uncertainty in EMC Measurements" and is documented in the Shenzhen CTL Testing Technology Co., Ltd. quality system acc. to DIN EN ISO/IEC 17025. Furthermore, component and process variability of devices similar to that tested may result in additional deviation. The manufacturer has the sole responsibility of continued compliance of the device.

Hereafter the best measurement capability for CTL laboratory is reported:

Test	Measurement Uncertainty	Notes
Transmitter power conducted	± 0.57 dB	(1)
Transmitter power Radiated	± 2.20 dB	(1)
Conducted spurious emission 9KHz-40 GHz	± 1.60 dB	(1)
Occupied Bandwidth	± 0.20 ppm	(1)
Radiated Emission 9KHz~30MHz	± 3.66 dB	(1)
Radiated Emission 30~1000MHz	± 4.10 dB	(1)
Radiated Emission Above 1GHz	± 4.32 dB	(1)
Conducted Disturbance 0.15~30MHz	± 3.20 dB	(1)

(1) This uncertainty represents an expanded uncertainty expressed at approximately the 95% confidence level using a coverage factor of $k=1.96$.

1.5. EUT configuration

The following peripheral devices and interface cables were connected during the measurement:

- - supplied by the manufacturer
- - supplied by the lab

<input type="radio"/>	Notebook computer	Manufacturer :	Huawei Technologies Co Ltd
		Model No. :	KPL-W00
<input type="radio"/>	HUAWEI SuperCharge	Manufacturer :	Huawei Technologies Co Ltd.
		Model No. :	HW-200200CP1

2. GENERAL INFORMATION

2.1. Environmental conditions

During the measurement the environmental conditions were within the listed ranges:

Normal Temperature:	25°C
Relative Humidity:	55 %
Air Pressure:	101 kPa

2.2. General Description of EUT

Product Name:	WIFI module		
Model/Type reference:	ALXC28		
Power supply:	DC 3.3V from host device		
WIFI 5GHz			
Supported type:	20MHz system	40MHz system	80MHz system
	802.11a 802.11n	802.11n	N/A
Operation frequency:	5180MHz-5240MHz 5260MHz-5320MHz 5500MHz-5700MHz 5745MHz-5825MHz	5190MHz-5230MHz 5270MHz-5310MHz 5510MHz-5670MHz 5755MHz-5795MHz	N/A
Modulation:	OFDM	OFDM	N/A
Channel number:	24	11	N/A
Channel separation:	20MHz	40MHz	N/A
Antenna type:	FPC Antenna		
Antenna gain:	3.46 dBi		

Note1: For more details, please refer to the user's manual of the EUT.

Note2: Antenna gain provided by the applicant.

Note3: This report is only for 5G WIFI.

2.3. Description of Test Modes and Test Frequency

The Applicant provides communication tools software to control the EUT for staying in continuous transmitting (Duty Cycle more than 98%) and receiving mode for testing.

All test performed at the low, middle and high of operational frequency range of each mode.

Operation Frequency List WIFI on 5G Band:

Operating band	20MHz		40MHz	
	Channel	Frequency (MHz)	Channel	Frequency (MHz)
U-NII 1 (5150MHz-5250MHz)	36	5180	38	5190
	40	5200		
	44	5220	46	5230
	48	5240		
U-NII 2A (5120MHz-5350MHz)	52	5260	54	5270
	56	5280		
	60	5300	62	5310
	64	5320		
U-NII 2C (5470MHz-5725MHz)	100	5500	102	5510
	104	5520		
	108	5540	110	5550
	112	5560		
	116	5580	118	5590
	120	5600		
	124	5620	126	5630
	128	5640		
	132	5660	134	5670
	136	5680		
140	5700	--	--	
U-NII 3 (5725MHz-5850MHz)	149	5745	151	5755
	153	5765		
	157	5785	159	5795
	161	5805		
	165	5825	--	--

Note:

1. "--"Means no channel(s) available any more.
2. The line display in grey is those Channels/Frequencies select to test in this report for each operation mode.

Data Rate Used:

Preliminary tests were performed in different data rate to find the worst radiated emission. The data rate shown in the table below is the worst-case rate with respect to the specific test item. Investigation has been done on all the possible configurations for searching the worst cases. The following table is a list of the test modes shown in this test report.

Test Items	Mode	Data Rate
Maximum Conducted Output Power Power Spectral Density Emission Bandwidth(26dBm Bandwidth) Minimum Emission Bandwidth(6dBm Bandwidth) Undesirable emission Frequency Stability	11a/OFDM	6 Mbps
	11n(20MHz) /OFDM	7.2 Mbps
	11n(40MHz) /OFDM	15.0Mbps

2.4. Equipments Used during the Test

Test Equipment	Manufacturer	Model No.	Serial No.	Calibration Date	Calibration Due Date
LISN	R&S	ESH2-Z5	860014/010	2023/05/04	2024/05/03
Double cone logarithmic antenna	Schwarzbeck	VULB 9168	824	2023/02/13	2026/02/12
Horn Antenna	Ocean Microwave	OBH100400	26999002	2021/12/22	2024/12/21
EMI Test Receiver	R&S	ESCI	1166.5950.03	2023/05/04	2024/05/03
Spectrum Analyzer	Agilent	E4407B	MY41440676	2023/05/05	2024/05/04
Spectrum Analyzer	Agilent	N9020A	UE22220290	2023/05/05	2024/05/04
Spectrum Analyzer	Keysight	N9020A	MY53420874	2023/05/05	2024/05/04
Horn Antenna	Sunol Sciences Corp.	DRH-118	A062013	2021/12/23	2024/12/22
Active Loop Antenna	Da Ze	ZN30900A	/	2021/05/13	2024/05/12
Amplifier	Agilent	8449B	3008A02306	2023/05/04	2024/05/03
Amplifier	Agilent	8447D	2944A10176	2023/05/04	2024/05/03
Amplifier	Brief&Smart	LNA-4018	2104197	2023/05/05	2024/05/04
Temperature/Humidity Meter	Ji Yu	MC501	/	2023/05/09	2024/05/08
Power Sensor	Agilent	U2021XA	MY55130004	2023/05/05	2024/05/04
Power Sensor	Agilent	U2021XA	MY55130006	2023/05/05	2024/05/04
Power Sensor	Agilent	U2021XA	MY54510008	2023/05/05	2024/05/04
Power Sensor	Agilent	U2021XA	MY55060003	2023/05/05	2024/05/04
Spectrum Analyzer	RS	FSP	1164.4391.38	2023/05/05	2024/05/04
LISN	R&S	ESH2-Z5	860014/010	2023/05/04	2024/05/03
Test Software					
Name of Software			Version		
TST-PASS			V2.0		
EZ_EMG(Below 1GHz)			V1.1.4.2		
EZ_EMG((Above 1GHz)			V1.1.4.2		

2.5. Related Submittal(s) / Grant (s)

This submittal(s) (test report) is intended to comply with Section 15.407 of the FCC Part 15, Subpart E Rules.

2.6. Modifications

No modifications were implemented to meet testing criteria.

3. TEST CONDITIONS AND RESULTS

3.1. Conducted Emissions Test

LIMIT

According to FCC CFR Title 47 Part 15 Subpart C Section 15.207, AC Power Line Conducted Emissions Limits for Licence-Exempt Radio Apparatus as below:

Frequency range (MHz)	Limit (dBuV)	
	Quasi-peak	Average
0.15-0.5	66 to 56*	56 to 46*
0.5-5	56	46
5-30	60	50

* Decreases with the logarithm of the frequency.

TEST CONFIGURATION

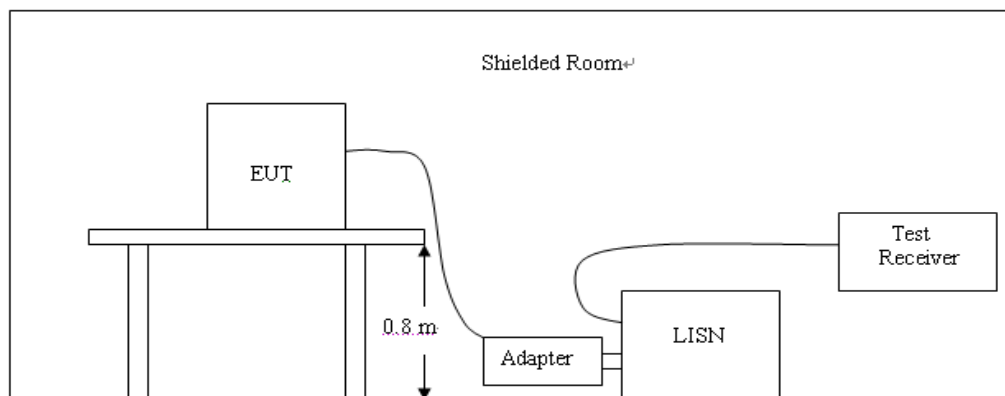

TEST PROCEDURE

1. The equipment was set up as per the test configuration to simulate typical actual usage per the user's manual. The EUT is a Laser Projector op system; a wooden table with a height of 0.8 meters is used and is placed on the ground plane as per ANSI C63.10:2013.
2. Support equipment, if needed, was placed as per ANSI C63.10:2013.
3. All I/O cables were positioned to simulate typical actual usage as per ANSI C63.10:2013.
4. The adapter received AC120V/60Hz power through a Line Impedance Stabilization Network (LISN) which supplied power source and was grounded to the ground plane.
5. All support equipments received AC power from a second LISN, if any.
6. The EUT test program was started. Emissions were measured on each current carrying line of the EUT using a spectrum Analyzer / Receiver connected to the LISN powering the EUT. The LISN has two monitoring points: Line 1 (Hot Side) and Line 2 (Neutral Side). Two scans were taken: one with Line 1 connected to Analyzer / Receiver and Line 2 connected to a 50 ohm load; the second scan had Line 1 connected to a 50 ohm load and Line 2 connected to the Analyzer / Receiver.
7. Analyzer / Receiver scanned from 150 KHz to 30MHz for emissions in each of the test modes.
8. During the above scans, the emissions were maximized by cable manipulation.

TEST RESULTS

1. Pre-scan all modes of IEEE 802.11a/n(HT20) /n (HT40) at Low, Middle, and High channel; only the worst result of was reported as below:
2. Both 120 VAC, 50/60 Hz and 240 VAC, 50/60 Hz power supply have been tested, only the worst result of 120 VAC, 60 Hz was reported as below:

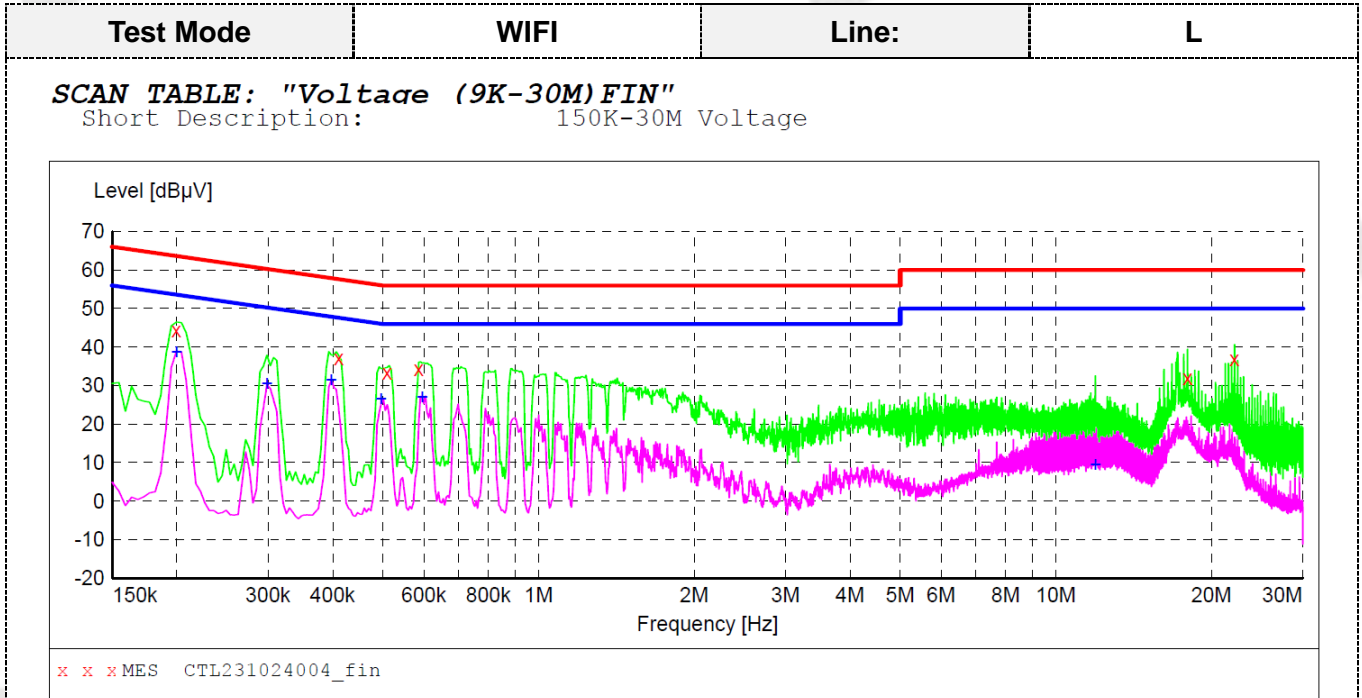

MEASUREMENT RESULT: "CTL231024004_fin"

10/24/2023 9:05AM

Frequency MHz	Level dBµV	Transd dB	Limit dBµV	Margin dB	Detector	Line	PE
0.199500	44.20	10.0	64	19.4	QP	L1	GND
0.411000	37.00	10.0	58	20.6	QP	L1	GND
0.510000	33.40	10.0	56	22.6	QP	L1	GND
0.586500	34.30	10.0	56	21.7	QP	L1	GND
17.961000	31.90	11.1	60	28.1	QP	L1	GND
22.146000	36.70	11.3	60	23.3	QP	L1	GND

MEASUREMENT RESULT: "CTL231024004_fin2"

10/24/2023 9:05AM

Frequency MHz	Level dBµV	Transd dB	Limit dBµV	Margin dB	Detector	Line	PE
0.199500	38.60	10.0	54	15.0	AV	L1	GND
0.298500	30.50	10.0	50	19.8	AV	L1	GND
0.397500	31.50	10.0	48	16.4	AV	L1	GND
0.496500	26.50	10.0	46	19.6	AV	L1	GND
0.595500	26.90	10.1	46	19.1	AV	L1	GND
11.913000	9.40	10.8	50	40.6	AV	L1	GND

Remark: Level(dBuV)=Reading(dBuV) + Transd.(dB)
 Margin=Limit(dBuV)- Level(dBuV)

Test Mode	WIFI	Line:	N
-----------	------	-------	---

SCAN TABLE: "Voltage (9K-30M)FIN"
 Short Description: 150K-30M Voltage

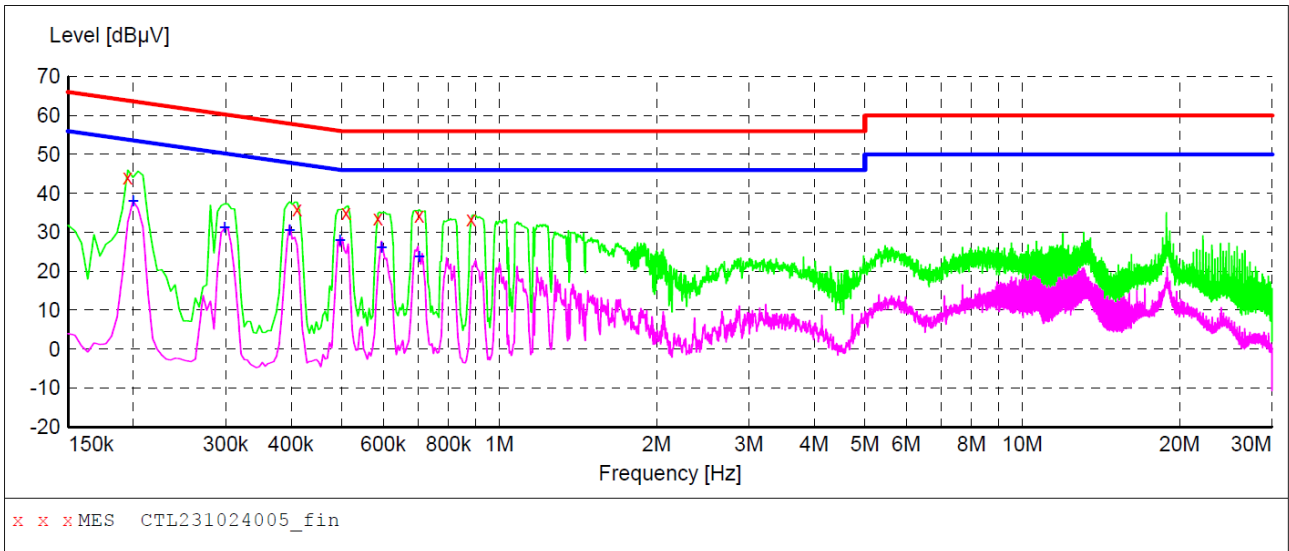

MEASUREMENT RESULT: "CTL231024005_fin"

10/24/2023 9:08AM

Frequency MHz	Level dBµV	Transd dB	Limit dBµV	Margin dB	Detector	Line	PE
0.195000	44.10	10.0	64	19.7	QP	N	GND
0.411000	36.00	10.0	58	21.6	QP	N	GND
0.510000	35.00	10.0	56	21.0	QP	N	GND
0.586500	33.50	10.0	56	22.5	QP	N	GND
0.703500	34.30	10.1	56	21.7	QP	N	GND
0.883500	33.20	10.1	56	22.8	QP	N	GND

MEASUREMENT RESULT: "CTL231024005_fin2"

10/24/2023 9:08AM

Frequency MHz	Level dBµV	Transd dB	Limit dBµV	Margin dB	Detector	Line	PE
0.199500	38.00	10.0	54	15.6	AV	N	GND
0.298500	31.20	10.0	50	19.1	AV	N	GND
0.397500	30.50	10.0	48	17.4	AV	N	GND
0.496500	28.00	10.0	46	18.1	AV	N	GND
0.595500	26.00	10.1	46	20.0	AV	N	GND
0.703500	23.80	10.1	46	22.2	AV	N	GND

Remark: Level(dBuV)=Reading(dBuV) + Transd.(dB)

Margin=Limit(dBuV)- Level(dBuV)

3.2. Radiated Emissions

Limit

The maximum emissions outside of the frequency bands of operation shall be attenuated in accordance with the following limits:

- (1) For transmitters operating in the 5.15-5.25 GHz band: All emissions outside of the 5.15-5.35 GHz band shall not exceed an e.i.r.p. of -27 dBm/MHz.
- (2) For transmitters operating in the 5.25-5.35 GHz band: All emissions outside of the 5.15-5.35 GHz band shall not exceed an e.i.r.p. of -27 dBm/MHz.
- (3) For transmitters operating in the 5.47-5.725 GHz band: All emissions outside of the 5.47-5.725 GHz band shall not exceed an e.i.r.p. of -27 dBm/MHz.
- (4) For transmitters operating in the 5.725-5.85 GHz band: All emissions shall be limited to a level of -27 dBm/MHz at 75 MHz or more above or below the band edge increasing linearly to 10 dBm/MHz at 25 MHz above or below the band edge, and from 25 MHz above or below the band edge increasing linearly to a level of 15.6 dBm/MHz at 5 MHz above or below the band edge, and from 5 MHz above or below the band edge increasing linearly to a level of 27 dBm/MHz at the band edge.

Undesirable emission limits

Requirement	Limit(EIRP)	Limit (Field strength at 3m) <small>Note1</small>
15.407(b)(1)	PK:-27(dBm/MHz)	PK:68.2(dBμV/m)
15.407(b)(2)		
15.407(b)(3)		
15.407(b)(4)		

Note1: The following formula is used to convert the equipment isotropic radiated power (eirp) to field strength:

$$E = \frac{1000000\sqrt{30P}}{3} \mu\text{V/m, where P is the eirp (Watts)}$$

- (5) Unwanted emissions below 1 GHz must comply with the general field strength limits set forth in §15.209
- (6) In addition, radiated emissions which fall in the restricted bands, as defined in §15.205(a), must also comply with the radiated emission limits specified in §15.209(a)

Radiated emission limits

Frequency (MHz)	Distance (Meters)	Radiated (dBμV/m)	Radiated (μV/m)
0.009-0.49	3	$20\log(2400/F(\text{KHz}))+40\log(300/3)$	$2400/F(\text{KHz})$
0.49-1.705	3	$20\log(24000/F(\text{KHz}))+40\log(30/3)$	$24000/F(\text{KHz})$
1.705-30	3	$20\log(30)+40\log(30/3)$	30
30-88	3	40.0	100
88-216	3	43.5	150
216-960	3	46.0	200
Above 960	3	54.0	500

TEST CONFIGURATION

(A) Radiated Emission Test Set-Up, Frequency Below 30MHz

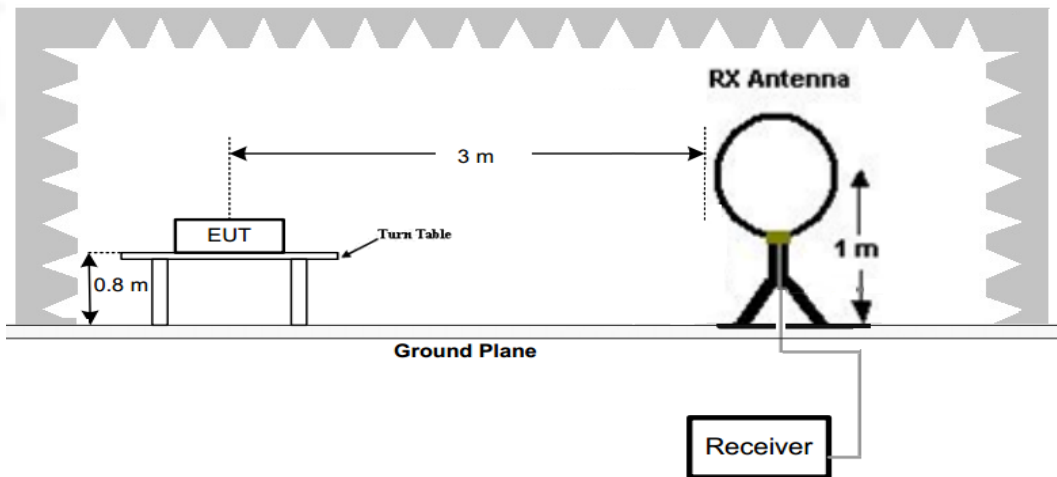

(B) Radiated Emission Test Set-Up, Frequency below 1000MHz

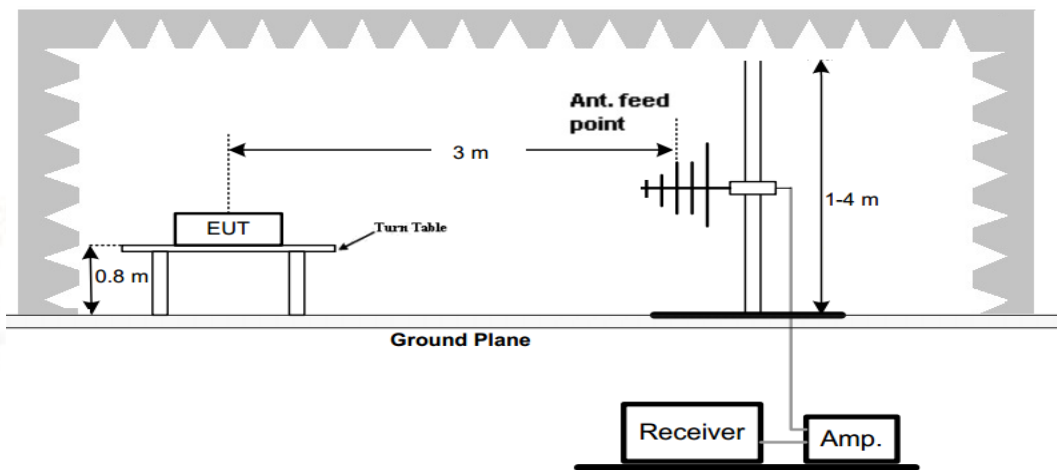

(C) Radiated Emission Test Set-Up, Frequency above 1000MHz

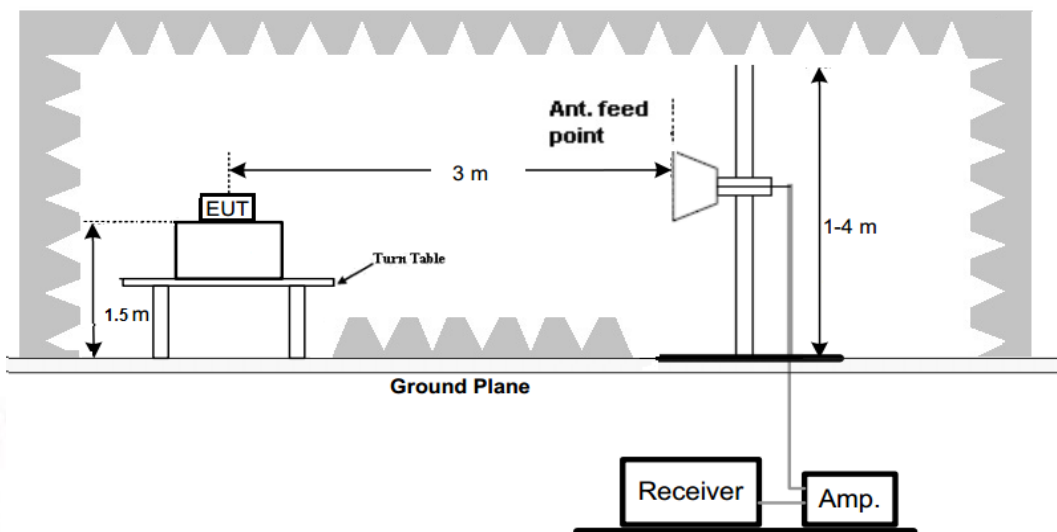

Test Procedure

- Below 1GHz measurement the EUT is placed on a turntable which is 0.8m above ground plane, and above 1GHz measurement EUT was placed on a low permittivity and low loss tangent turn table which is 1.5m above ground plane.
- Maximum procedure was performed by raising the receiving antenna from 1m to 4m and rotating the turn table from 0°C to 360°C to acquire the highest emissions from EUT
- And also, each emission was to be maximized by changing the polarization of receiving antenna both horizontal and vertical.
- Repeat above procedures until all frequency measurements have been completed.
- Radiated emission test frequency band from 9KHz to 40GHz.
- The distance between test antenna and EUT as following table states:

Test Frequency range	Test Antenna Type	Test Distance
9KHz-30MHz	Active Loop Antenna	3
30MHz-1GHz	Bilog Antenna	3
1GHz-18GHz	Horn Antenna	3
18GHz-25GHz	Horn Antenna	1

- Setting test receiver/spectrum as following table states:

Test Frequency range	Test Receiver/Spectrum Setting	Detector
9KHz-150KHz	RBW=200Hz/VBW=3KHz, Sweep time=Auto	QP
150KHz-30MHz	RBW=9KHz/VBW=100KHz, Sweep time=Auto	QP
30MHz-1GHz	RBW=120KHz/VBW=1000KHz, Sweep time=Auto	QP
1GHz-40GHz	Peak Value: RBW=1MHz/VBW=3MHz, Sweep time=Auto Average Value: RBW=1MHz/VBW=10Hz, Sweep time=Auto	Peak

TEST RESULTS

Remark:

- All 802.11a / 802.11n (HT20)/ 802.11n (HT40) modes have been tested for below 1GHz test, only the worst case 802.11n (HT20) low channel of U-NII 1 band was recorded.
- All 802.11a / 802.11n (HT20) / 802.11n (HT40) modes have been tested for above 1GHz test, only the worst case 802.11n (HT20) was recorded.
- All WIFI operation modes have been tested for U-NII 3 bandedge test, only the worst case of 802.11n(HT20) mode was recorded.
- Radiated emission test from 9 KHz to 10th harmonic of fundamental was verified, and no emission found except system noise floor in 9 KHz to 30MHz and not recorded in this report.

For 30MHz-1GHz

Horizontal



Shenzhen CTL Testing Technology Co., Ltd
Tel: +86-755-89486194

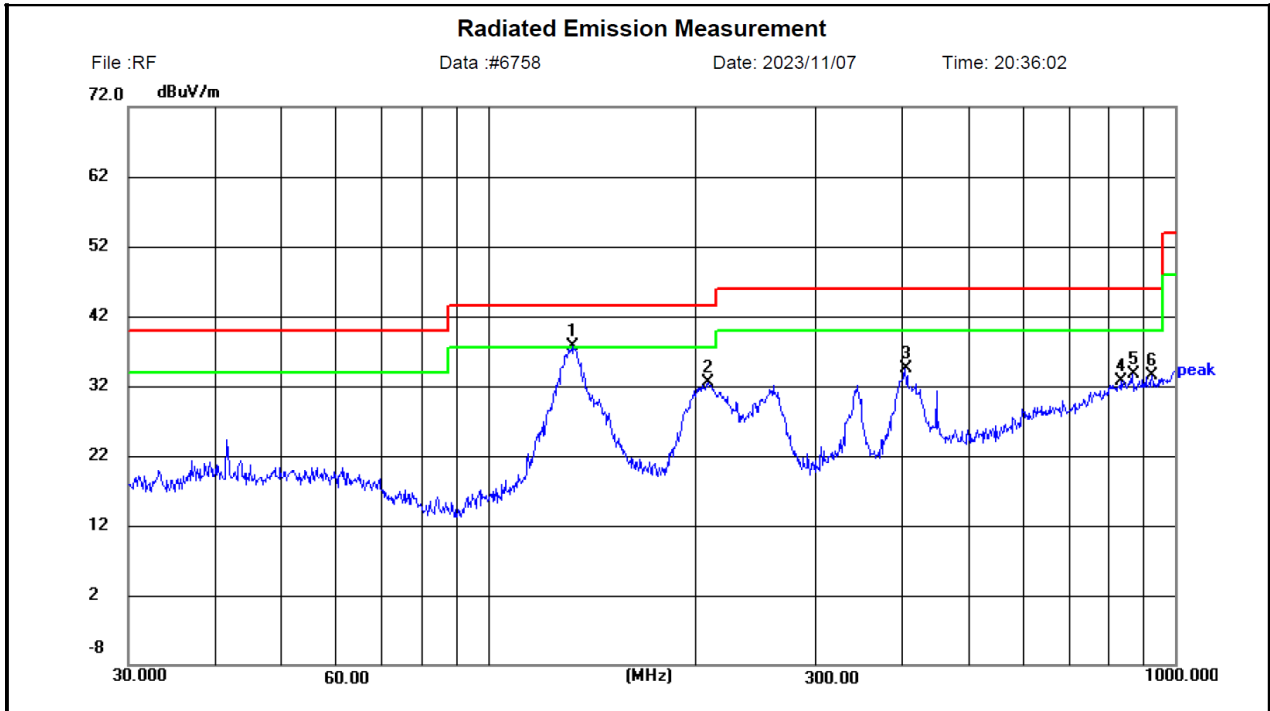

Site LAB Chamber 2
Limit: FCC Part15 RE-Class C_30-1000MHz
EUT: /
M/N: ALXC28
Mode: WIFI5.1G 5180MHz
Note: Edan Instruments, Inc

Polarization: **Horizontal**
Power:
Distance: 3m

Temperature: 25(C)
Humidity: 50 %

No.	Frequency (MHz)	Reading (dBuV)	Factor (dB/m)	Level (dBuV/m)	Limit (dBuV/m)	Margin (dB)	Detector	Height (cm)	Azimuth (deg.)	P/F	Remark
1	133.1510	24.26	13.38	37.64	43.50	5.86	peak	100	351	P	
2	209.3129	20.86	11.56	32.42	43.50	11.08	peak	100	342	P	
3	404.6665	16.91	17.60	34.51	46.00	11.49	peak	100	84	P	
4	833.3171	7.57	25.20	32.77	46.00	13.23	peak	100	316	P	
5	866.0879	8.16	25.57	33.73	46.00	12.27	peak	100	307	P	
6	925.7562	7.34	26.14	33.48	46.00	12.52	peak	100	109	P	

Remark: Level(dBuV/m)=Reading(dBuV)+Factor(dB/m)
Margin= Limit(dBuV/m)- Level(dBuV/m)

Vertical



Shenzhen CTL Testing Technology Co., Ltd
Tel: +86-755-89486194

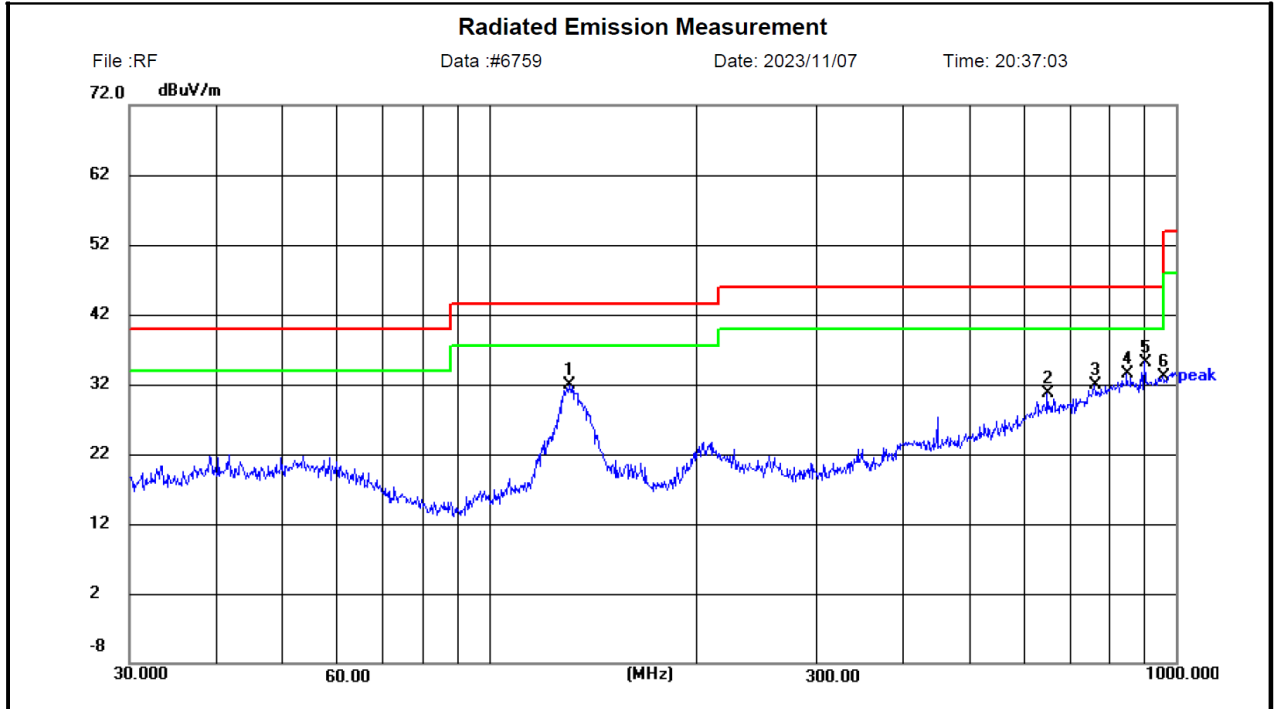

File :RF Data :#6759 Date: 2023/11/07 Time: 20:37:03

Site LAB Chamber 2 Polarization: **Vertical** Temperature: 25(C)
 Limit: FCC Part15 RE-Class C_30-1000MHz Power: Humidity: 50 %
 EUT: / Distance: 3m
 M/N: ALXC28
 Mode: WIFI5.1G 5180MHz
 Note: Edan Instruments, Inc

No.	Frequency (MHz)	Reading (dBuV)	Factor (dB/m)	Level (dBuV/m)	Limit (dBuV/m)	Margin (dB)	Detector	Height (cm)	Azimuth (deg.)	P/F	Remark
1	130.8369	18.46	13.36	31.82	43.50	11.68	peak	100	122	P	
2	649.6597	8.66	21.98	30.64	46.00	15.36	peak	100	336	P	
3	760.7036	7.79	24.12	31.91	46.00	14.09	peak	100	105	P	
4	848.0563	8.06	25.52	33.58	46.00	12.42	peak	100	53	P	
5	900.1474	9.32	25.88	35.20	46.00	10.80	peak	100	285	P	
6	955.4381	6.68	26.36	33.04	46.00	12.96	peak	100	70	P	

Remark: Level(dBuV/m)=Reading(dBuV)+Factor(dB/m)
 Margin= Limit(dBuV/m)- Level(dBuV/m)

U-NII 3 & 802.11n (HT20) Mode (above 1GHz)

Tested Channel	Frequency (MHz)	Emission Level (dBuV/m)	Detector Mode	ANT Pol	Limit (dBuV/m)	Margin (dB)	Raw Value (dBuV)	Antenna Factor (dB/m)	Cable Factor (dB)	Pre amplifier (dB)	Correction Factor (dB/m)
149 (5745MHz)	11490.00	49.16	PK	H	68.20	19.04	30.90	39.69	12.90	34.33	18.26
	--	--	--	--	--	--	--	--	--	--	--
157 (5785MHz)	11570.00	50.15	PK	H	68.20	18.05	31.70	39.71	13.05	34.31	18.45
	--	--	--	--	--	--	--	--	--	--	--
165 (5825MHz)	11650.00	48.54	PK	H	68.20	19.66	29.92	39.73	13.19	34.30	18.62
	--	--	--	--	--	--	--	--	--	--	--

Tested Channel	Frequency (MHz)	Emission Level (dBuV/m)	Detector Mode	ANT Pol	Limit (dBuV/m)	Margin (dB)	Raw Value (dBuV)	Antenna Factor (dB/m)	Cable Factor (dB)	Pre amplifier (dB)	Correction Factor (dB/m)
149 (5745MHz)	11490.00	49.53	PK	V	68.20	18.67	31.27	39.69	12.90	34.33	18.26
	--	--	--	--	--	--	--	--	--	--	--
157 (5785MHz)	11570.00	50.64	PK	V	68.20	17.56	32.19	39.71	13.05	34.31	18.45
	--	--	--	--	--	--	--	--	--	--	--
165 (5825MHz)	11650.00	49.53	PK	V	68.20	18.67	30.91	39.73	13.19	34.30	18.62
	--	--	--	--	--	--	--	--	--	--	--

REMARKS:

1. Emission level (dBuV/m) =Raw Value (dBuV)+Correction Factor (dB/m)
2. Correction Factor (dB/m) = Antenna Factor (dB/m)+Cable Factor (dB)-Pre-amplifier Factor
3. Margin value = Limit value- Emission level.
4. -- Mean the other emission levels were very low against the limit.
5. RBW1MHz VBW3MHz Peak detector is for PK value; RBW 1MHz VBW10Hz Peak detector is for AV value.
6. Worst case data at 6Mbps at IEEE 802.11a; MCS0 at IEEE 802.11n HT20, IEEE 802.11n HT40.

Band Edge Test Plots of U-NII 3

802.11n (HT20) mode@ Ch149_5745MHz



Shenzhen CTL Testing Technology Co., Ltd
Tel: +86-755-89486194

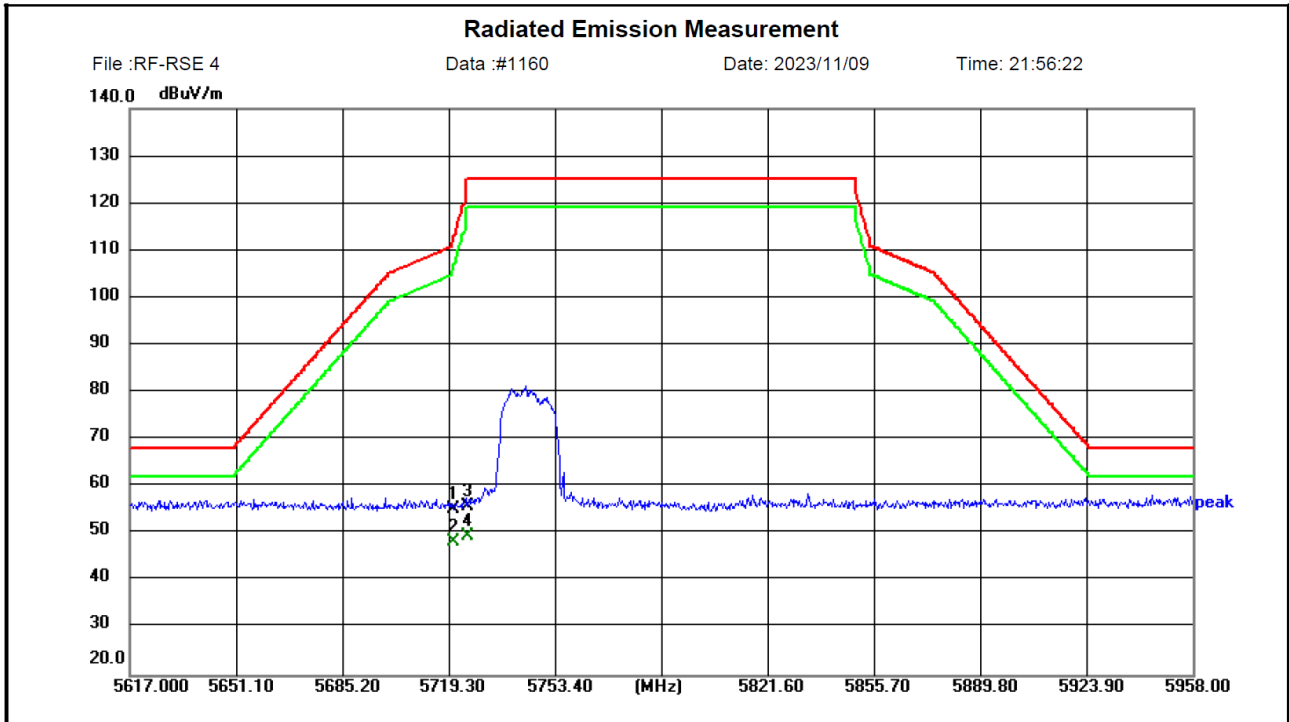

Site LAB Chamber 2
Limit: 5725-5850 BAND
EUT:
M/N: ALXC28
Mode: WIFI5.8G 5745MHz TX
Note: Edan Instruments, Inc

Polarization: *Horizontal*
Power:
Distance: 3m

Temperature: 25(C)
Humidity: 50 %

No.	Frequency (MHz)	Reading (dBUV)	Factor (dB/m)	Level (dBUV/m)	Limit (dBUV/m)	Margin (dB)	Detector	Height (cm)	Azimuth (deg.)	P/F	Remark
1	5720.664	37.08	18.11	55.19	112.31	57.12	peak	150	360	P	
2	5720.664	30.31	18.11	48.42	112.31	63.89	AVG	150	0	P	
3	5725.097	37.88	18.12	56.00	125.20	69.20	peak	150	360	P	
4	5725.097	31.50	18.12	49.62	125.20	75.58	AVG	150	0	P	



Shenzhen CTL Testing Technology Co., Ltd
Tel: +86-755-89486194

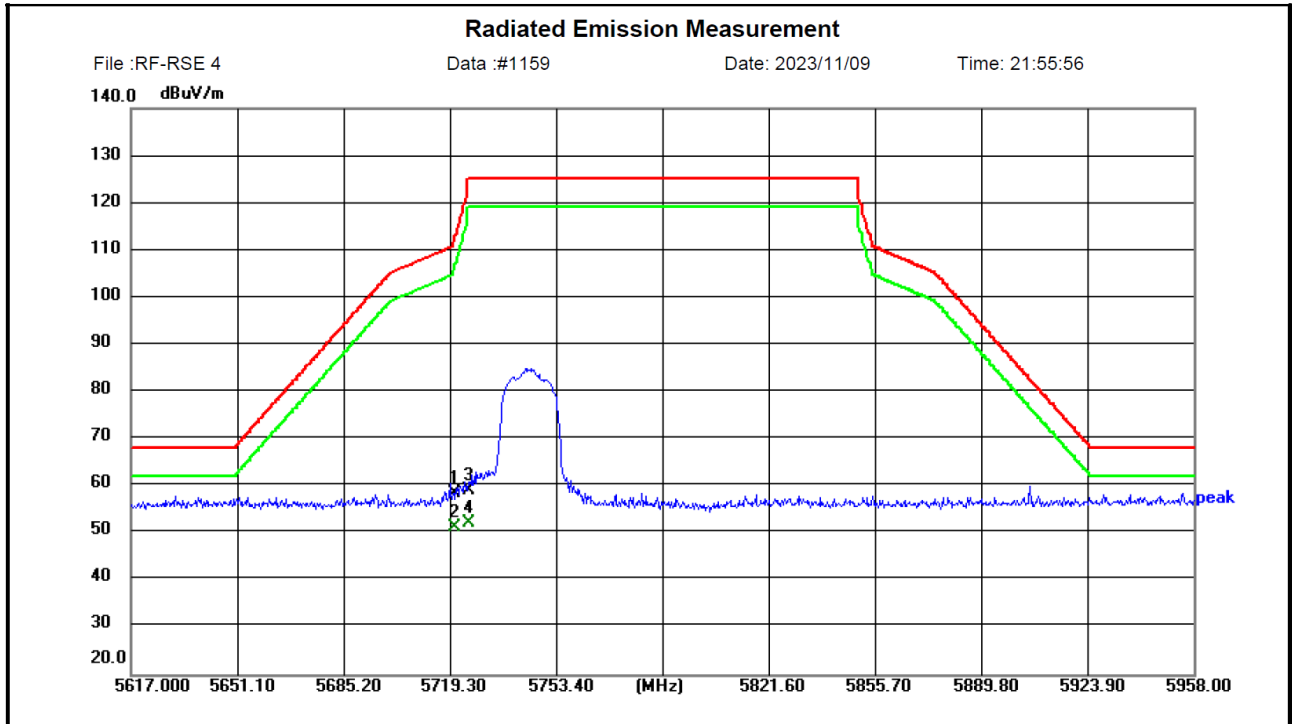

Site LAB Chamber 2	Polarization: <i>Vertical</i>	Temperature: 25(C)
Limit: 5725-5850 BAND	Power:	Humidity: 50 %
EUT:	Distance: 3m	
M/N: ALXC28		
Mode: WIFI5.8G 5745MHz TX		
Note: Edan Instruments, Inc		

No.	Frequency (MHz)	Reading (dBuV)	Factor (dB/m)	Level (dBuV/m)	Limit (dBuV/m)	Margin (dB)	Detector	Height (cm)	Azimuth (deg.)	P/F	Remark
1	5720.664	40.48	18.11	58.59	112.31	53.72	peak	150	360	P	
2	5720.664	33.31	18.11	51.42	112.31	60.89	AVG	150	0	P	
3	5725.097	41.00	18.12	59.12	125.20	66.08	peak	150	360	P	
4	5725.097	34.00	18.12	52.12	125.20	73.08	AVG	150	0	P	

Band Edge Test Plots

802.11n (HT20) mode@ Ch165_5825MHz



Shenzhen CTL Testing Technology Co., Ltd
Tel: +86-755-89486194

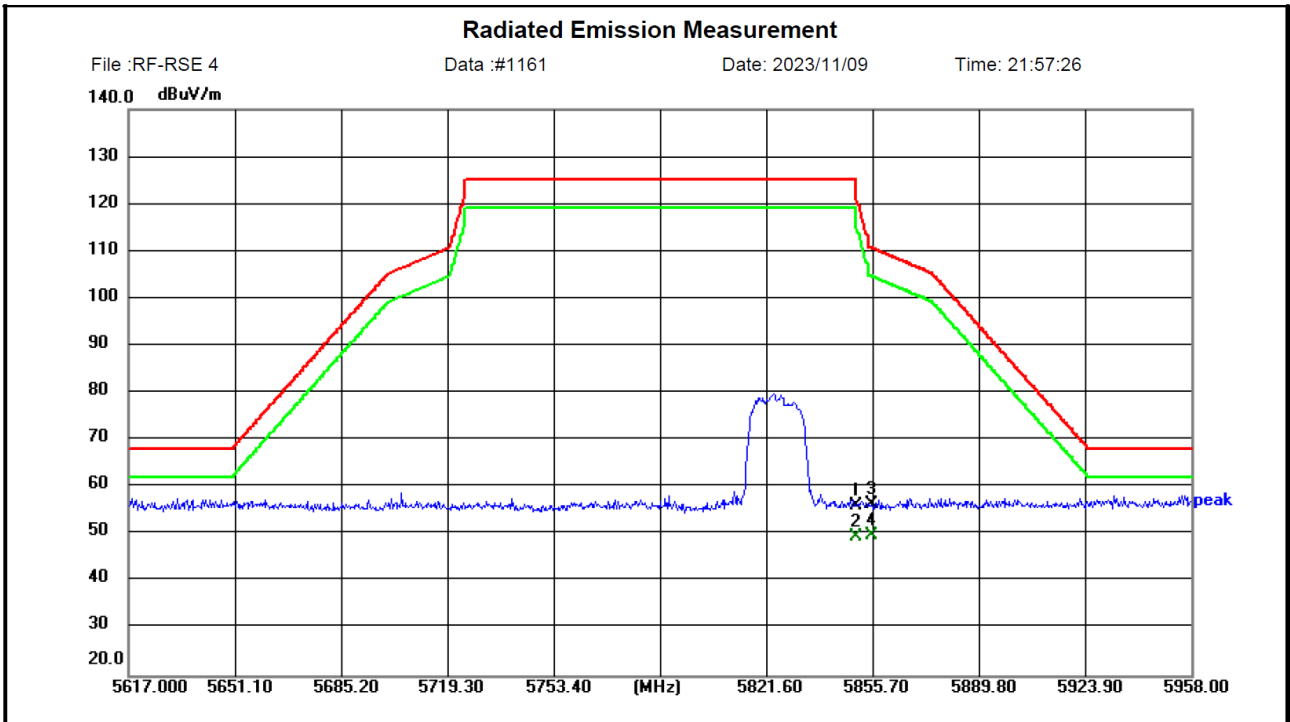

File :RF-RSE 4 Data :#1161 Date: 2023/11/09 Time: 21:57:26

Site LAB Chamber 2 Polarization: *Horizontal* Temperature: 25(C)
 Limit: 5725-5850 BAND Power: Humidity: 50 %
 EUT: Distance: 3m
 M/N: ALXC28
 Mode: WIFI5.8G 5825MHz TX
 Note: Edan Instruments, Inc

No.	Frequency (MHz)	Reading (dBuV)	Factor (dB/m)	Level (dBuV/m)	Limit (dBuV/m)	Margin (dB)	Detector	Height (cm)	Azimuth (deg.)	P/F	Remark
1	5850.585	37.82	18.30	56.12	120.87	64.75	peak	150	360	P	
2	5850.585	31.32	18.30	49.62	120.87	71.25	AVG	150	0	P	
3	5855.359	38.24	18.32	56.56	110.70	54.14	peak	150	360	P	
4	5855.359	31.55	18.32	49.87	110.70	60.83	AVG	150	0	P	



Shenzhen CTL Testing Technology Co., Ltd
Tel: +86-755-89486194

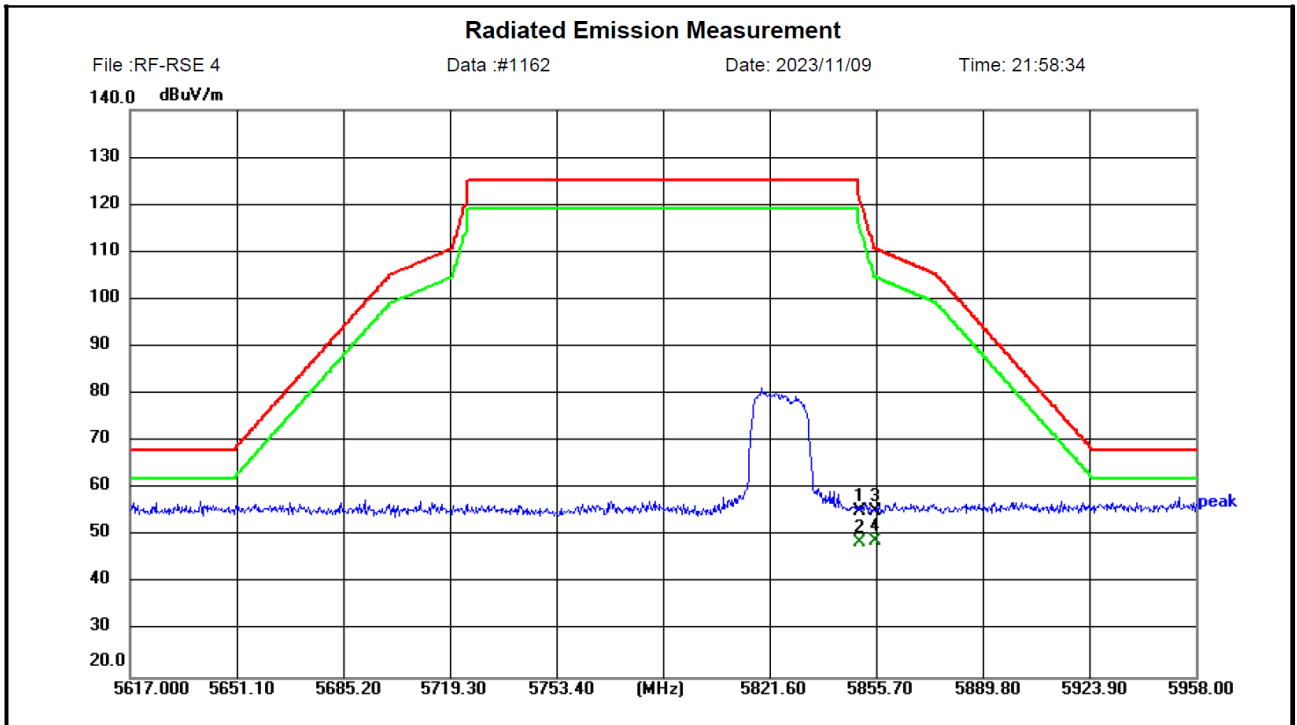

Site LAB Chamber 2	Polarization: Vertical	Temperature: 25(C)
Limit: 5725-5850 BAND	Power:	Humidity: 50 %
EUT:	Distance: 3m	
M/N: ALXC28		
Mode: WIFI5.8G 5825MHz TX		
Note: Edan Instruments, Inc		

No.	Frequency (MHz)	Reading (dBuV)	Factor (dB/m)	Level (dBuV/m)	Limit (dBuV/m)	Margin (dB)	Detector	Height (cm)	Azimuth (deg.)	P/F	Remark
1	5850.244	37.10	18.30	55.40	121.64	66.24	peak	150	360	P	
2	5850.244	30.50	18.30	48.80	121.64	72.84	AVG	150	0	P	
3	5855.359	37.03	18.32	55.35	110.70	55.35	peak	150	360	P	
4	5855.359	30.55	18.32	48.87	110.70	61.83	AVG	150	0	P	

3.3. Maximum Conducted Average Output Power

Limit

FCC requirement:

For the band 5.15-5.25 GHz.

(i) For an outdoor access point operating in the band 5.15-5.25 GHz, the maximum conducted output power over the frequency band of operation shall not exceed 1 W provided the maximum antenna gain does not exceed 6dBi.

(ii) For an indoor access point operating in the band 5.15-5.25 GHz, the maximum conducted output power over the frequency band of operation shall not exceed 1 W provided the maximum antenna gain does not exceed 6dBi.

(iii) For fixed point-to-point access points operating in the band 5.15-5.25 GHz, the maximum conducted output power over the frequency band of operation shall not exceed 1 W.

(iv) For client devices in the 5.15-5.25 GHz band, the maximum conducted output power over the frequency band of operation shall not exceed 250mW provided the maximum antenna gain does not exceed 6dBi.

For the 5.25-5.35 GHz and 5.47-5.725 GHz bands, the maximum conducted output power over the frequency bands of operation shall not exceed the lesser of 250mW or $11\text{dBm} + 10\log B$, where B is the 26 dB emission bandwidth in megahertz.

For the band 5.725-5.85 GHz, the maximum conducted output power over the frequency band of operation shall not exceed 1 W

Test Procedure

Remove the antenna from the EUT and then connect a low loss RF cable from the antenna port to the spectrum.

Test Configuration

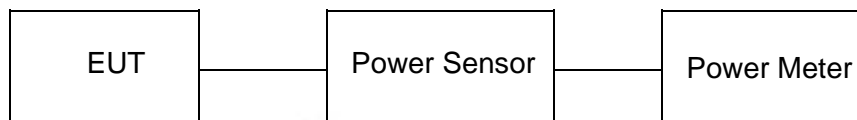

Test Results

Raw data reference to Appendix RF test data for 5G_U-NII BAND1 & Appendix RF test data for 5G_U-NII BAND2A & Appendix RF test data for 5G_U-NII BAND2C & Appendix RF test data for 5G_U-NII BAND3.

3.4. Power Spectral Density

Limit

FCC requirement:

For the band 5.15-5.25 GHz.

- (i) For an outdoor access point operating in the band 5.15 - 5.25 GHz, the maximum power spectral density shall not exceed 17dBm in any 1 MHz band.^{note1}
- (ii) For an indoor access point operating in the band 5.15 - 5.25 GHz, the maximum power spectral density shall not exceed 17dBm in any 1 MHz band.^{note1}
- (iii) For fixed point-to-point access points operating in the band 5.15 - 5.25 GHz, transmitters that employ a directional antenna gain greater than 23dBi, a 1 dB reduction in maximum power spectral density is required for each 1 dB of antenna gain in excess of 23dBi.
- (iv) For mobile and portable client devices in the 5.15 - 5.25 GHz band, the maximum power spectral density shall not exceed 11dBm in any 1 MHz band.^{note1}

For the 5.25-5.35 GHz and 5.47-5.725 GHz bands

The maximum power spectral density shall not exceed 11dBm in any 1 megahertz band.

IC requirement:

For the band 5.15-5.25 GHz.

The e.i.r.p. spectral density shall not exceed 10dBm in any 1.0 MHz band.

Frequency band 5250-5350 MHz

The power spectral density shall not exceed 11dBm in any 1.0 MHz band

Frequency bands 5470-5600 MHz and 5650-5725 MHz

The power spectral density shall not exceed 11dBm in any 1.0 MHz band.

For the band 5.725 - 5.85 GHz

The maximum power spectral density shall not exceed 30dBm in any 500 kHz band.^{note1, note2}

Note1: If transmitting antennas of directional gain greater than 6dBi are used, the peak power spectral density shall be reduced by the amount in dB that the directional gain of the antenna exceeds 6dBi.

Note2: Fixed point - to-point U-NII devices operating in this band may employ transmitting antennas with directional gain greater than 6dBi without any corresponding reduction in transmitter conducted power. Fixed, point-to-point operations exclude the use of point-to-multipoint systems, omnidirectional applications, and multiple collocated transmitters transmitting the same information.

Test Procedure

1. Use this procedure when the maximum peak conducted output power in the fundamental emission is used to demonstrate compliance.
2. Set the RBW = 1MHz for U-NII 1, U-NII 2A, U-NII C band and 510KHz for U-NII 3 band.
3. Set the VBW $\geq 3 \times$ RBW.
4. Set the span to encompass the entire EBW.
5. Detector = Average.
6. Sweep time = auto couple.
7. Trace mode = max hold.
8. Allow trace to fully stabilize.
9. Use the peak marker function to determine the maximum power level.

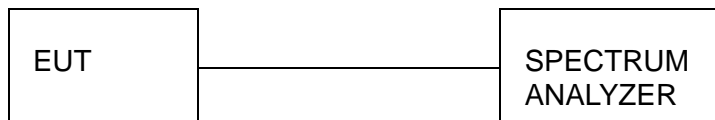
Test Configuration**Test Results**

Raw data reference to Appendix RF test data for 5G_U-NII BAND1 & Appendix RF test data for 5G_U-NII BAND2A & Appendix RF test data for 5G_U-NII BAND2C & Appendix RF test data for 5G_U-NII BAND3.

3.5. Emission Bandwidth (26dBm Bandwidth)

Limit

N/A

Test Procedure

1. Set resolution bandwidth (RBW) = approximately 1 % of the EBW.
2. Set the video bandwidth (VBW) > RBW.
3. Detector = Peak.
4. Trace mode = Max hold.
5. Measure the maximum width of the emission that is 26 dB down from the peak of the emission. Compare this with the RBW setting of the analyzer. Readjust RBW and repeat measurement as needed until the RBW / EBW ratio is approximately 1 %.

Test Configuration

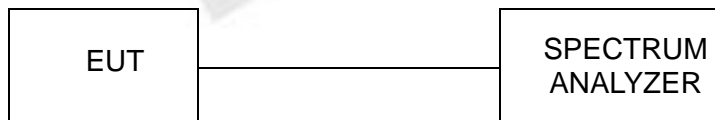

Test Results

Raw data reference to Appendix RF test data for 5G_U-NII BAND1 & Appendix RF test data for 5G_U-NII BAND2A & Appendix RF test data for 5G_U-NII BAND2C.

3.6. Minimum Emission Bandwidth (6dBm Bandwidth)

Limit

Section 15.407(e) specifies the minimum 6 dB emission bandwidth of at least 500 kHz for the band 5.725-5.85 GHz

Test Procedure

1. Set resolution bandwidth (RBW) = 100 kHz
2. Set the video bandwidth 3 x RBW.
3. Detector = Peak.
4. Trace mode = Max hold.
5. Measure the maximum width of the emission that is constrained by the frequencies associated with the two outermost amplitude points (upper and lower frequencies) that are attenuated by 6 dB relative to the maximum level measured in the fundamental emission.

Test Configuration

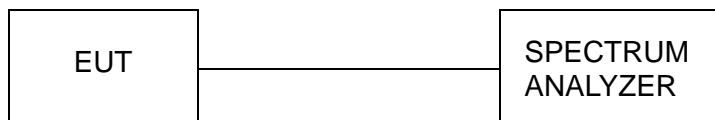

Test Results

Raw data reference to Appendix RF test data for 5G_U-NII BAND3.

3.7. Frequency Stability

LIMIT

Manufacturers of U-NII devices are responsible for ensuring frequency stability such that an emission is maintained within the band of operation under all conditions of normal operation as specified in the users manual.

TEST CONFIGURATION

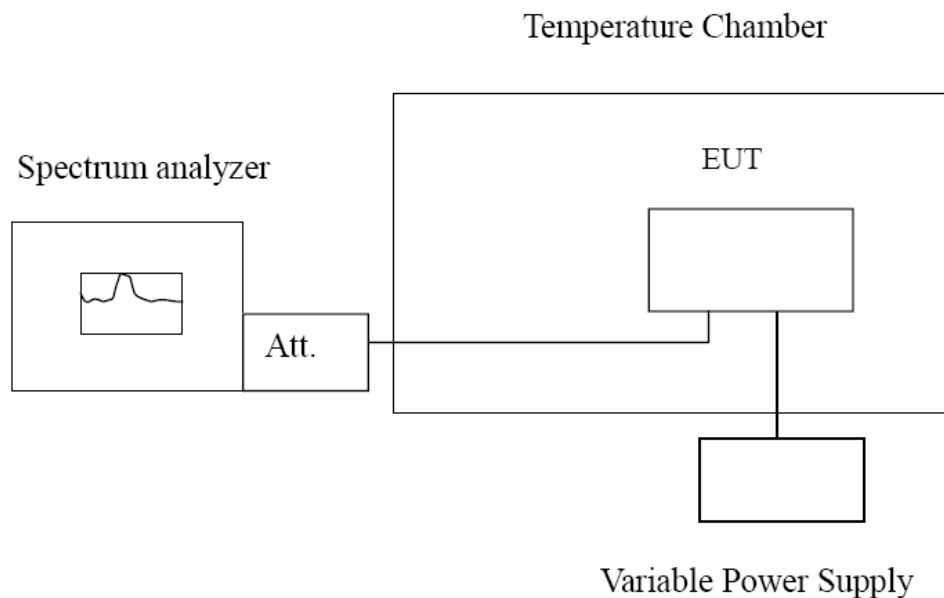

TEST PROCEDURE

Frequency Stability under Temperature Variations:

The equipment under test was connected to an external AC or DC power supply and input rated voltage. RF output was connected to a frequency counter or spectrum analyzer via feed through attenuators. The EUT was placed inside the temperature chamber. Set the spectrum analyzer RBW low enough to obtain the desired frequency resolution and measure EUT 20°C operating frequency as reference frequency. Turn EUT off and set the chamber temperature to -30°C. After the temperature stabilized for approximately 30 minutes recorded the frequency. Repeat step measure with 10°C increased per stage until the highest temperature of +85°C reached.

Frequency Stability under Voltage Variations:

Set chamber temperature to 20°C. Use a variable AC power supply / DC power source to power the EUT and set the voltage to rated voltage. Set the spectrum analyzer RBW low enough to obtain the desired frequency resolution and recorded the frequency. Reduce the input voltage to specify extreme voltage variation ($\pm 15\%$) and endpoint, record the maximum frequency change.

TEST RESULTS

Raw data reference to Appendix RF test data for 5G_U-NII BAND1 & Appendix RF test data for 5G_U-NII BAND2A & Appendix RF test data for 5G_U-NII BAND2C & Appendix RF test data for 5G_U-NII BAND3.

3.8. Antenna Requirement

Standard Applicable

For intentional device, according to FCC 47 CFR Section 15.203:

An intentional radiator shall be designed to ensure that no antenna other than that furnished by the responsible party shall be used with the device. The use of a permanently attached antenna or of an antenna that uses a unique coupling to the intentional radiator, the manufacturer may design the unit so that a broken antenna can be replaced by the user, but the use of a standard antenna jack or electrical connector is prohibited

And according to FCC 47 CFR Section 15.407 (a), if transmitting antennas of directional gain greater than 6dBi are used, the power shall be reduced by the amount in dB that the directional gain of the antenna exceeds 6dBi.

Refer to statement below for compliance

The manufacturer may design the unit so that the user can replace a broken antenna, but the use of a standard antenna jack or electrical connector is prohibited. Further, this requirement does not apply to intentional radiators that must be professionally installed.

Antenna Connected Construction

The maximum gain of Antenna was 3.46dBi for 5G WLAN.

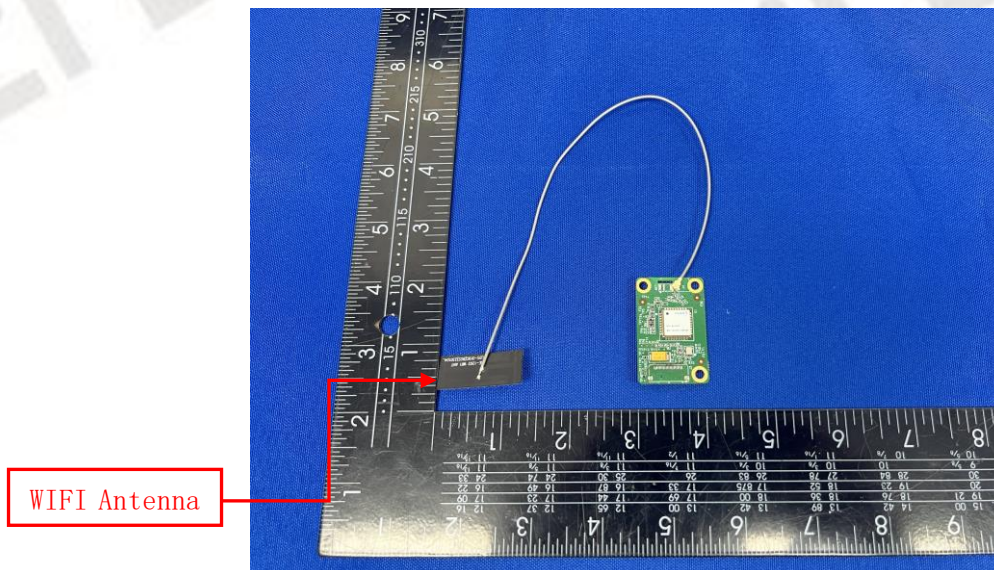

4. Test Setup Photos of the EUT

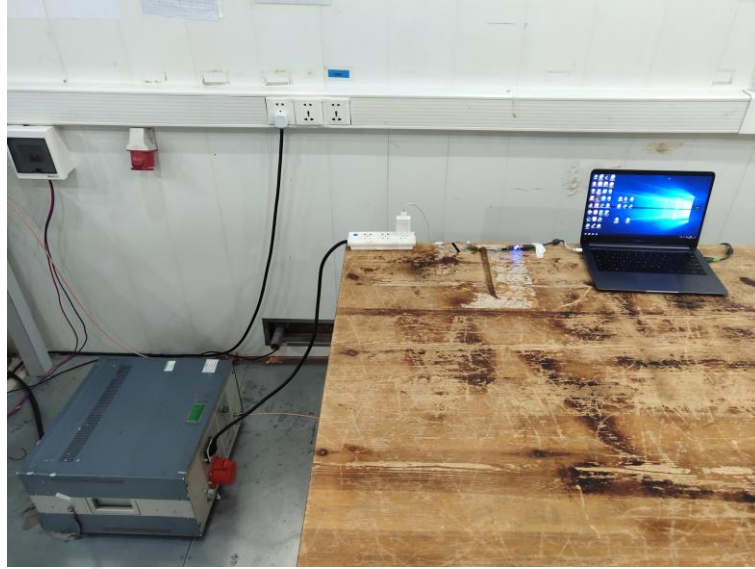

5. Photos of the EUT

Reference to the test report No. CTL2310129032-WF01

***** End of Report *****