



Shenzhen CTL Testing Technology Co., Ltd.  
Tel: +86-755-89486194 E-mail: ctl@ctl-lab.com

# TEST REPORT

## FCC PART 15.247

Report Reference No. .... : CTL2304069012-WF

Compiled by: Happy Guo  
( position+printed name+signature) (File administrators)

Tested by: Peng Tang  
( position+printed name+signature) (Test Engineer)

Approved by: Ivan Xie  
( position+printed name+signature) (Manager)

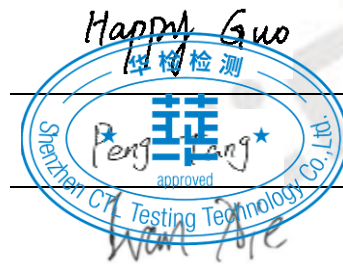

Product Name ..... : Bluetooth Module

Model/Type reference ..... : SD6

List Model(s)..... : N/A

Trade Mark..... : N/A

FCC ID..... : SMQSD6-MAIN

Applicant's name ..... : Edan Instruments, Inc

Address of applicant ..... : #15 Jinhui Road, Jinsha Community, Kengzi Sub-District,  
Pingshan District,518122 Shenzhen P.R.China

Test Firm..... : Shenzhen CTL Testing Technology Co., Ltd.

Address of Test Firm ..... : Floor 1-A, Baisha Technology Park, No.3011, Shahexi Road,  
Nanshan District, Shenzhen, China 518055

Test specification..... :

Standard ..... : FCC Part 15.247: Operation within the bands 902-928 MHz,  
2400-2483.5 MHz and 5725-5850 MHz.

TRF Originator ..... : Shenzhen CTL Testing Technology Co., Ltd.

Master TRF..... : Dated 2011-01

Date of receipt of test item ..... : Apr. 06, 2023

Date of Test Date..... : Apr. 12, 2023-Apr. 13, 2023

Date of Issue ..... : May 05, 2023

Result..... : Pass

**Shenzhen CTL Testing Technology Co., Ltd. All rights reserved.**

This publication may be reproduced in whole or in part for non-commercial purposes as long as the Shenzhen CTL Testing Technology Co., Ltd. is acknowledged as copyright owner and source of the material. Shenzhen CTL Testing Technology Co., Ltd. takes no responsibility for and will not assume liability for damages resulting from the reader's interpretation of the reproduced material due to its placement and context.

# TEST REPORT

<b>Test Report No. :</b> CTL2304069012-WF	May 05, 2023
	Date of issue

Equipment under Test : Bluetooth Module

Sample No : CTL230406901-1-S001

Model /Type : SD6

Listed Models : N/A

**Applicant** : **Edan Instruments, Inc**

Address : #15 Jinhui Road, Jinsha Community, Kengzi  
Sub-District, Pingshan District, 518122 Shenzhen  
P.R.China

**Manufacturer** : **Edan Instruments, Inc**

Address : #15 Jinhui Road, Jinsha Community, Kengzi  
Sub-District, Pingshan District, 518122 Shenzhen  
P.R.China

<b>Test result</b>	<b>Pass *</b>
--------------------	---------------

\* In the configuration tested, the EUT complied with the standards specified page 5.

The test results presented in this report relate only to the object tested.

This report shall not be reproduced, except in full, without the written approval of the issuing testing laboratory.



**Table of Contents**

**Page**

**1. SUMMARY ..... 5**

1.1. TEST STANDARDS ..... 5

1.2. TEST DESCRIPTION ..... 5

1.3. TEST FACILITY..... 6

1.4. STATEMENT OF THE MEASUREMENT UNCERTAINTY ..... 7

**2. GENERAL INFORMATION..... 8**

2.1. ENVIRONMENTAL CONDITIONS ..... 8

2.2. GENERAL DESCRIPTION OF EUT ..... 8

2.3. DESCRIPTION OF TEST MODES AND TEST FREQUENCY ..... 9

2.4. EQUIPMENTS USED DURING THE TEST..... 10

2.5. RELATED SUBMITTAL(S) / GRANT (S) ..... 10

2.6. MODIFICATIONS ..... 10

**3. TEST CONDITIONS AND RESULTS ..... 11**

3.1. CONDUCTED EMISSIONS TEST ..... 11

3.2. RADIATED EMISSIONS AND BAND EDGE..... 14

3.3. MAXIMUM CONDUCTED OUTPUT POWER..... 28

3.4. POWER SPECTRAL DENSITY..... 29

3.5. 6DB BANDWIDTH ..... 30

3.6. OUT-OF-BAND EMISSIONS ..... 31

3.7. ANTENNA REQUIREMENT ..... 32

**4. TEST SETUP PHOTOS OF THE EUT ..... 33**

**5. PHOTOS OF THE EUT ..... 35**

# 1. SUMMARY

## 1.1. TEST STANDARDS

The tests were performed according to following standards:

[FCC Rules Part 15.247](#): Frequency Hopping, Direct Spread Spectrum and Hybrid Systems that are in operation within the bands of 902-928 MHz, 2400-2483.5 MHz, and 5725-5850 MHz

[ANSI C63.10: 2013](#): American National Standard for Testing Unlicensed Wireless Devices

[KDB 558074 D01 v05r02](#): KDB558074 D01 15.247 Meas Guidance v05r02

## 1.2. Test Description

FCC PART 15.247		
FCC Part 15.207	AC Power Conducted Emission	PASS
FCC Part 15.247(a)(2)	6dB Bandwidth	PASS
FCC Part 15.247(d)	Spurious RF Conducted Emission	PASS
FCC Part 15.247(b)	Maximum Conducted Output Power	PASS
FCC Part 15.247(e)	Power Spectral Density	PASS
FCC Part 15.109/ 15.205/ 15.209	Radiated Emissions	PASS
FCC Part 15.247(d)	Band Edge	PASS
FCC Part 15.203/15.247 (b)	Antenna Requirement	PASS

## 1.3. Test Facility

### 1.3.1 Address of the test laboratory

Shenzhen CTL Testing Technology Co.,Ltd.

Floor 1-A, Baisha Technology Park, No. 3011, Shahexi Road, Nanshan, Shenzhen 518055 China

There is one 3m semi-anechoic chamber and two line conducted labs for final test. The Test Sites meet the requirements in documents ANSI C63.10 and CISPR 32/EN 55032 requirements.

### 1.3.2 Laboratory accreditation

The test facility is recognized, certified, or accredited by the following organizations:

#### **CNAS-Lab Code: L7497**

Shenzhen CTL Testing Technology Co., Ltd. has been assessed and proved to be in compliance with CNAS-CL01 Accreditation Criteria for Testing and Calibration Laboratories (identical to ISO/IEC 17025: 2017 General Requirements) for the Competence of Testing and Calibration Laboratories.

#### **A2LA-Lab Cert. No. 4343.01**

Shenzhen CTL Testing Technology Co., Ltd, EMC Laboratory has been accredited by A2LA for technical competence in the field of electrical testing, and proved to be in compliance with ISO/IEC 17025: 2017 General Requirements for the Competence of Testing and Calibration Laboratories and any additional program requirements in the identified field of testing.

#### **IC Registration No.: 9618B**

#### **CAB identifier: CN0041**

The 3m alternate test site of Shenzhen CTL Testing Technology Co., Ltd. EMC Laboratory has been registered by Innovation, Science and Economic Development Canada to test to Canadian radio equipment requirements with Registration No.: 9618B on Jan. 22, 2019.

#### **FCC-Registration No.: 399832**

#### **Designation No.: CN1216**

Shenzhen CTL Testing Technology Co., Ltd. EMC Laboratory has been registered and fully described in a report filed with the (FCC) Federal Communications Commission. The acceptance letter from the FCC is maintained in our files. Registration 399832, December 08, 2017.

## 1.4. Statement of the measurement uncertainty

The data and results referenced in this document are true and accurate. The reader is cautioned that there may be errors within the calibration limits of the equipment and facilities. The measurement uncertainty was calculated for all measurements listed in this test report acc. to CISPR 16 - 4 "Specification for radio disturbance and immunity measuring apparatus and methods – Part 4: Uncertainty in EMC Measurements" and is documented in the Shenzhen CTL Testing Technology Co., Ltd. quality system acc. to DIN EN ISO/IEC 17025. Furthermore, component and process variability of devices similar to that tested may result in additional deviation. The manufacturer has the sole responsibility of continued compliance of the device.

Hereafter the best measurement capability for CTL laboratory is reported:

Test	Measurement Uncertainty	Notes
Transmitter power conducted	±0.57 dB	(1)
Transmitter power Radiated	±2.20 dB	(1)
Conducted spurious emission 9KHz-40 GHz	±1.60 dB	(1)
Occupied Bandwidth	±0.20ppm	(1)
Radiated Emission 9KHz~30MHz	±3.66dB	(1)
Radiated Emission 30~1000MHz	±4.10dB	(1)
Radiated Emission Above 1GHz	±4.32dB	(1)
Conducted Disturbance 0.15~30MHz	±3.20dB	(1)

- (1) This uncertainty represents an expanded uncertainty expressed at approximately the 95% confidence level using a coverage factor of k=2.

## 2. GENERAL INFORMATION

### 2.1. Environmental conditions

During the measurement the environmental conditions were within the listed ranges:

Normal Temperature:	25°C
Relative Humidity:	55 %
Air Pressure:	101 kPa

### 2.2. General Description of EUT

Product Name:	Bluetooth Module
Model/Type reference:	SD6
Power supply:	DC 3.3V
<b>Bluetooth LE 1M</b>	
Supported type:	Bluetooth Low Energy
Modulation:	GFSK
Operation frequency:	2402MHz to 2480MHz
Channel number:	40
Channel separation:	1MHz
Antenna type:	PIFA Antenna
Antenna gain:	2.63dBi
<b>Bluetooth LE 2M</b>	
Supported type:	Bluetooth Low Energy
Modulation:	GFSK
Operation frequency:	2402MHz to 2480MHz
Channel number:	40
Channel separation:	2MHz
Antenna type:	PIFA Antenna
Antenna gain:	2.63dBi

Note1: For more details, please refer to the user's manual of the EUT.

Note2: Antenna gain provided by the applicant.



## 2.3. Description of Test Modes and Test Frequency

The Applicant provides communication tools software to control the EUT for staying in continuous transmitting and receiving mode for testing.

There are 40 channels provided to the EUT and Channel 00/19/39 were selected for BLE test.

Test Modes	BLE 1M Continuous Transmitting	BLE 2M Continuous Transmitting
1	■	
2		■

### Operation Frequency List :

Channel	Frequency (MHz)
<b>00</b>	<b>2402</b>
02	2404
03	2406
⋮	⋮
<b>19</b>	<b>2440</b>
⋮	⋮
37	2476
38	2478
<b>39</b>	<b>2480</b>

Note: The line display in grey were the channel selected for testing

## 2.4. Equipments Used during the Test

Test Equipment	Manufacturer	Model No.	Serial No.	Calibration Date	Calibration Due Date
LISN	R&S	ESH2-Z5	860014/010	2022/05/07	2023/05/06
Double cone logarithmic antenna	Schwarzbeck	VULB 9168	824	2023/02/13	2026/02/12
Horn Antenna	Ocean Microwave	OBH100400	26999002	2021/12/22	2024/12/21
EMI Test Receiver	R&S	ESCI	1166.5950.03	2022/05/07	2023/05/06
Spectrum Analyzer	Agilent	E4407B	MY41440676	2022/05/07	2023/05/06
Spectrum Analyzer	Agilent	N9020A	US46220290	2022/05/07	2023/05/06
Spectrum Analyzer	Keysight	N9020A	MY53420874	2022/05/07	2023/05/06
Horn Antenna	Sunol Sciences Corp.	DRH-118	A062013	2021/12/23	2024/12/22
Active Loop Antenna	Da Ze	ZN30900A	/	2021/05/13	2024/05/12
Amplifier	Agilent	8449B	3008A02306	2022/05/07	2023/05/06
Amplifier	Agilent	8447D	2944A10176	2022/05/06	2023/05/05
Amplifier	MRT	MRT-AP01M06	S-001	2022/05/07	2023/05/06
Amplifier	Brief&Smart	LNA-4018	2104197	2022/05/07	2023/05/06
Temperature/Humidity Meter	Ji Yu	MC501	/	2022/05/07	2023/05/06
Power Sensor	Agilent	U2021XA	MY55130004	2022/05/07	2023/05/06
Power Sensor	Agilent	U2021XA	MY55130006	2022/05/07	2023/05/06
Power Sensor	Agilent	U2021XA	MY54510008	2022/05/07	2023/05/06
Power Sensor	Agilent	U2021XA	MY55060003	2022/05/07	2023/05/06
Spectrum Analyzer	RS	FSP	1164.4391.38	2022/05/07	2023/05/06
Test Software					
Name of Software			Version		
TST-PASS			V1.1.0		
EZ_EMG(Below 1GHz)			V1.1.4.2		
EZ_EMG((Above 1GHz)			V1.1.4.2		

The calibration interval was one year

## 2.5. Related Submittal(s) / Grant (s)

This submittal(s) (test report) is intended to comply with Section 15.247 of the FCC Part 15, Subpart C Rules.

## 2.6. Modifications

No modifications were implemented to meet testing criteria.

### 3. TEST CONDITIONS AND RESULTS

#### 3.1. Conducted Emissions Test

##### LIMIT

FCC CFR Title 47 Part 15 Subpart C Section 15.207

Frequency range (MHz)	Limit (dBuV)	
	Quasi-peak	Average
0.15-0.5	66 to 56*	56 to 46*
0.5-5	56	46
5-30	60	50

\* Decreases with the logarithm of the frequency.

##### TEST CONFIGURATION

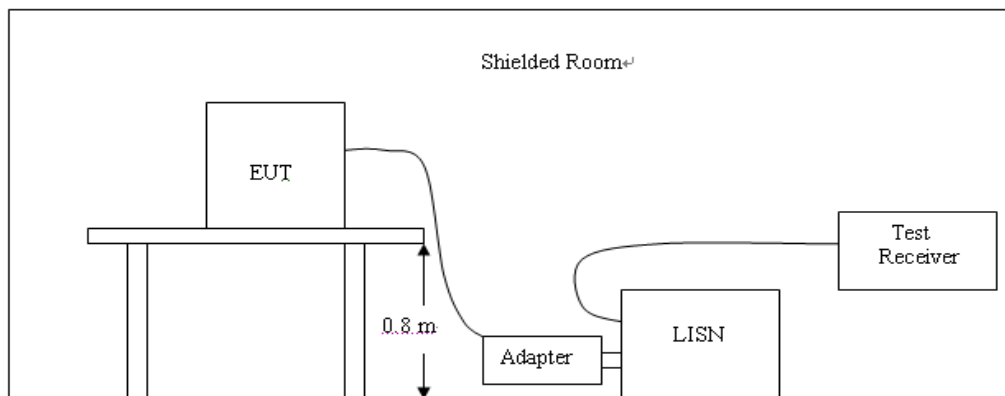

##### TEST PROCEDURE

1. The equipment was set up as per the test configuration to simulate typical actual usage per the user's manual. The EUT is a tabletop system; a wooden table with a height of 0.8 meters is used and is placed on the ground plane as per ANSI C63.10:2013.
2. Support equipment, if needed, was placed as per ANSI C63.10:2013.
3. All I/O cables were positioned to simulate typical actual usage as per ANSI C63.10:2013.
4. The adapter received AC120V/60Hz power through a Line Impedance Stabilization Network (LISN) which supplied power source and was grounded to the ground plane.
5. All support equipments received AC power from a second LISN, if any.
6. The EUT test program was started. Emissions were measured on each current carrying line of the EUT using a spectrum Analyzer / Receiver connected to the LISN powering the EUT. The LISN has two monitoring points: Line 1 (Hot Side) and Line 2 (Neutral Side). Two scans were taken: one with Line 1 connected to Analyzer / Receiver and Line 2 connected to a 50 ohm load; the second scan had Line 1 connected to a 50 ohm load and Line 2 connected to the Analyzer / Receiver.
7. Analyzer / Receiver scanned from 150 KHz to 30MHz for emissions in each of the test modes.
8. During the above scans, the emissions were maximized by cable manipulation.

**TEST RESULTS**

Remarks: All modes were tested, with only the following worst mode being captured (Test Mode 1)

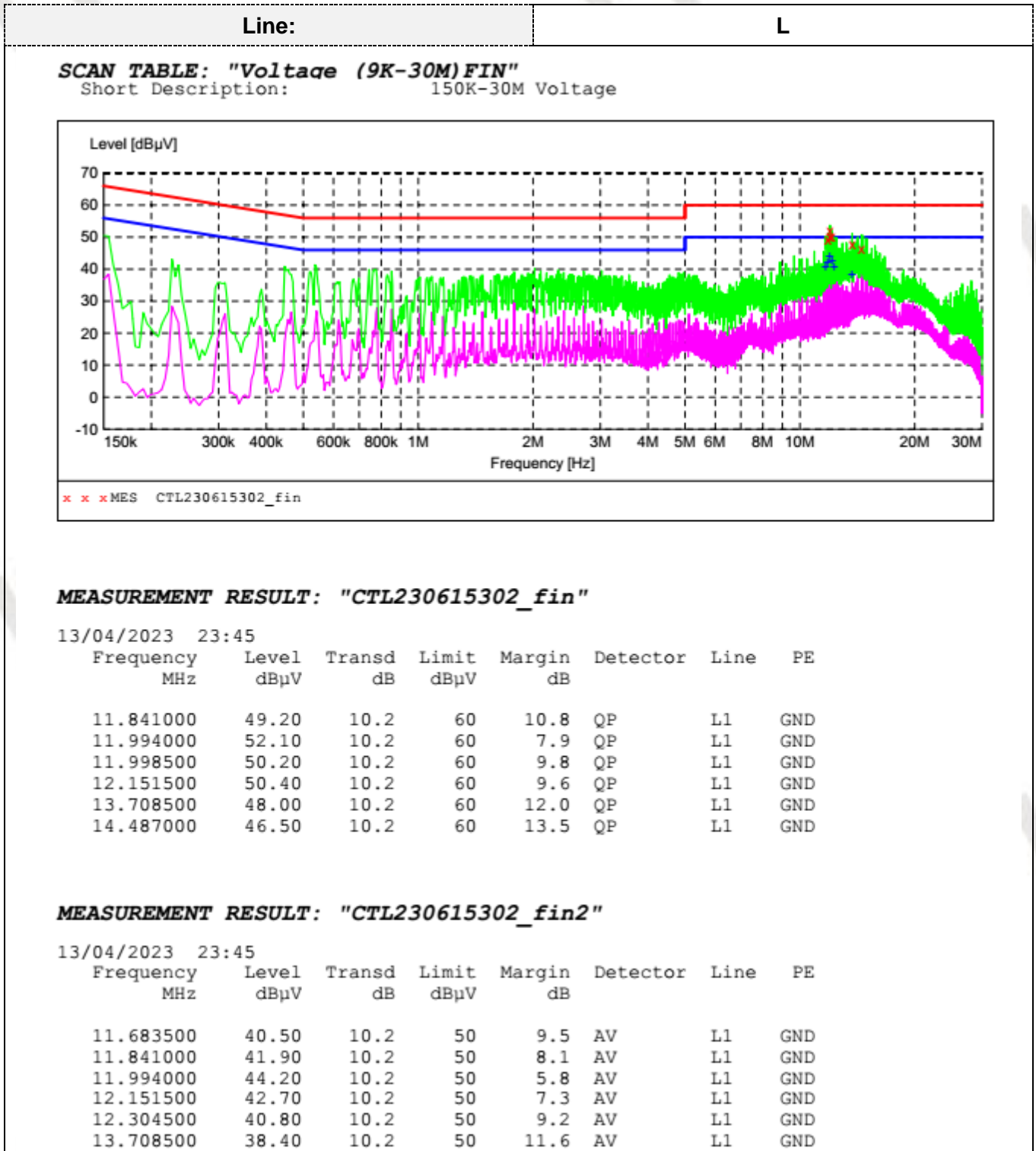

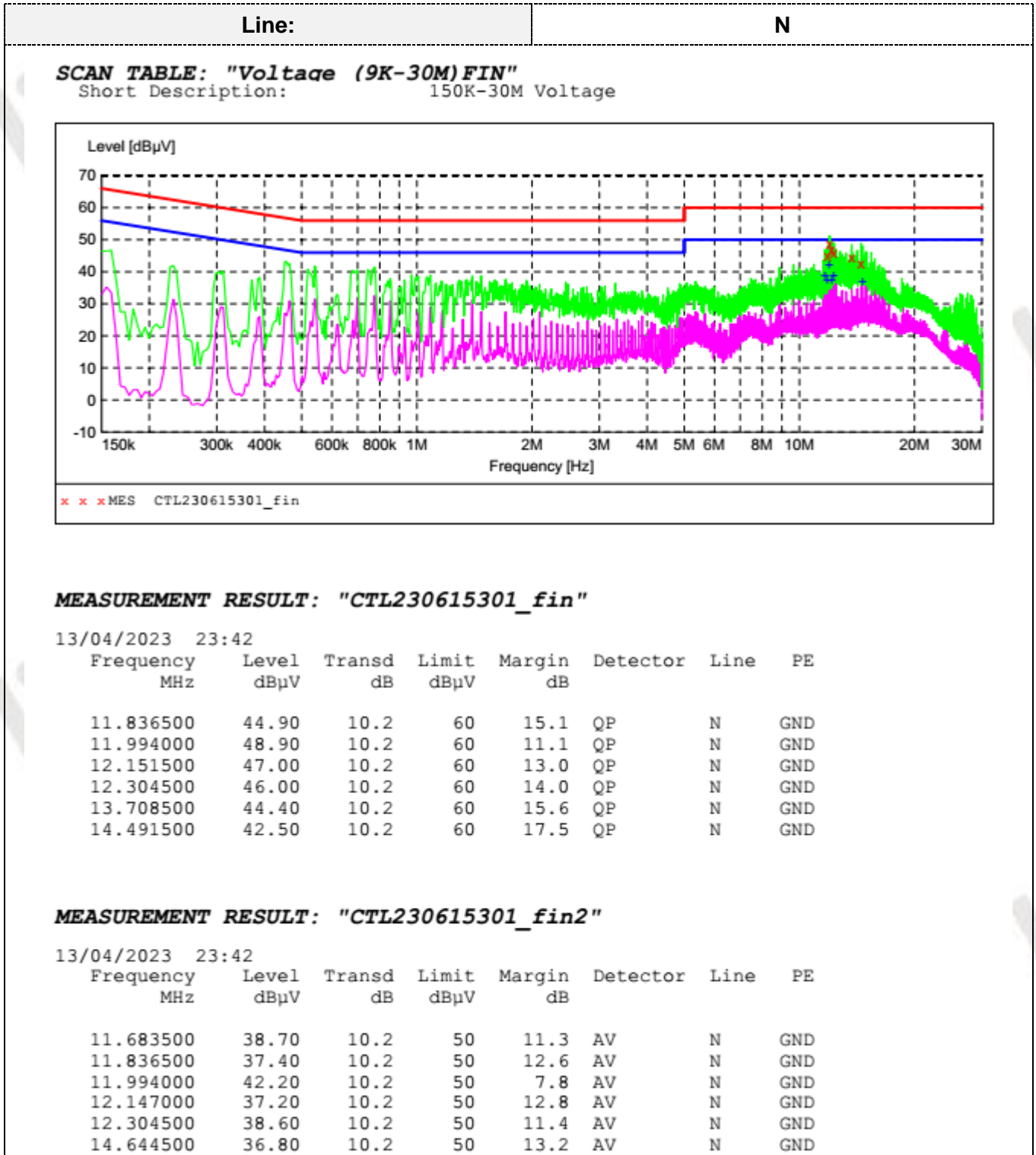

Remark: Level(dBuV)=Reading(dBuV) + Transd.(dB)

Margin=Limit(dBuV)- Level(dBuV)

### 3.2. Radiated Emissions and Band Edge

#### Limit

For intentional device, according to § 15.209(a), the general requirement of field strength of radiated emission out of authorized band shall not exceed the following table at a 3 meters measurement distance.

In addition, radiated emissions which fall in the restricted bands, as defined in §15.205(a), must also comply with the radiated emission limits specified in §15.209(a)

Radiated emission limits

Frequency (MHz)	Distance (Meters)	Radiated (dBµV/m)	Radiated (µV/m)
0.009-0.49	3	$20\log(2400/F(\text{KHz}))+40\log(300/3)$	$2400/F(\text{KHz})$
0.49-1.705	3	$20\log(24000/F(\text{KHz}))+40\log(30/3)$	$24000/F(\text{KHz})$
1.705-30	3	$20\log(30)+40\log(30/3)$	30
30-88	3	40.0	100
88-216	3	43.5	150
216-960	3	46.0	200
Above 960	3	54.0	500

#### TEST CONFIGURATION

(A) Radiated Emission Test Set-Up, Frequency Below 30MHz

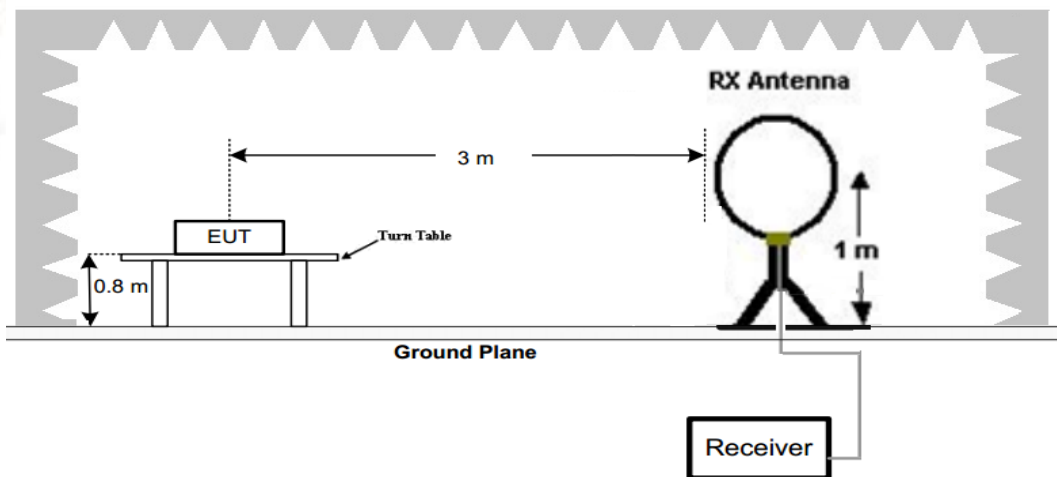

(B) Radiated Emission Test Set-Up, Frequency below 1000MHz

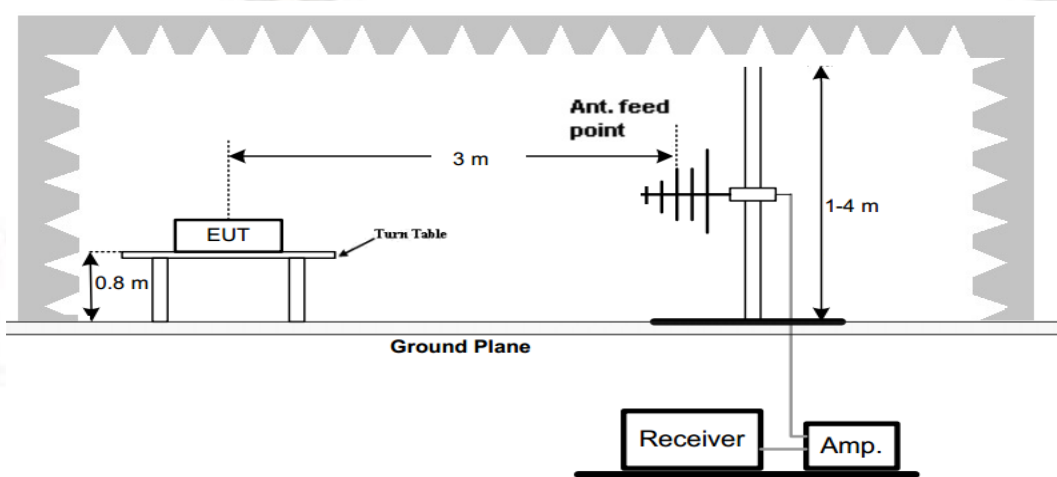

## (C) Radiated Emission Test Set-Up, Frequency above 1000MHz

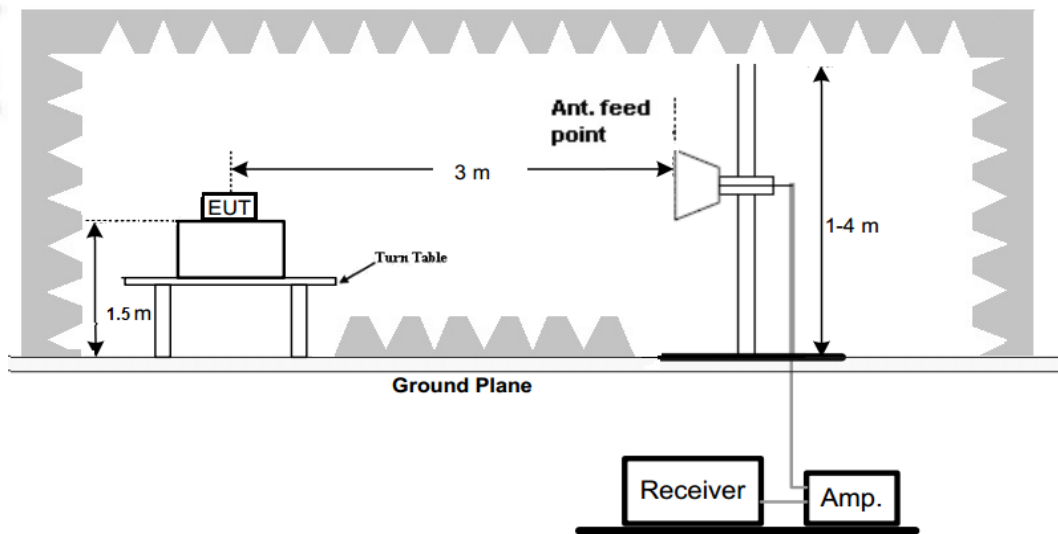
**Test Procedure**

1. Below 1GHz measurement the EUT is placed on a turntable which is 0.8m above ground plane, and above 1GHz measurement EUT was placed on a low permittivity and low loss tangent turn table which is 1.5m above ground plane.
2. Maximum procedure was performed by raising the receiving antenna from 1m to 4m and rotating the turn table from 0° to 360° to acquire the highest emissions from EUT
3. And also, each emission was to be maximized by changing the polarization of receiving antenna both horizontal and vertical.
4. Repeat above procedures until all frequency measurements have been completed.
5. The EUT was pretested with 3 orientations placed on the table for the radiated emission measurement –X, Y, and Z-plane. The X-plane results were found as the worst case and were shown in this report.

**TEST RESULTS**

Remark:

1. For below 1GHz testing recorded worst at test mode 2 low channel.
2. Radiated emission test from 9 KHz to 10th harmonic of fundamental was verified, Found the emission level are attenuated 20dB below the limits from 9 kHz to 30MHz, so it does not recorded in report.

For 30MHz-1GHz

Horizontal



Shenzhen CTL Testing Technology Co., Ltd  
 Tel: +86-755-89486194  
 Floor 1-A, Baisha Technology Park, No.3011, Shahexi Road, Nanshan District, She

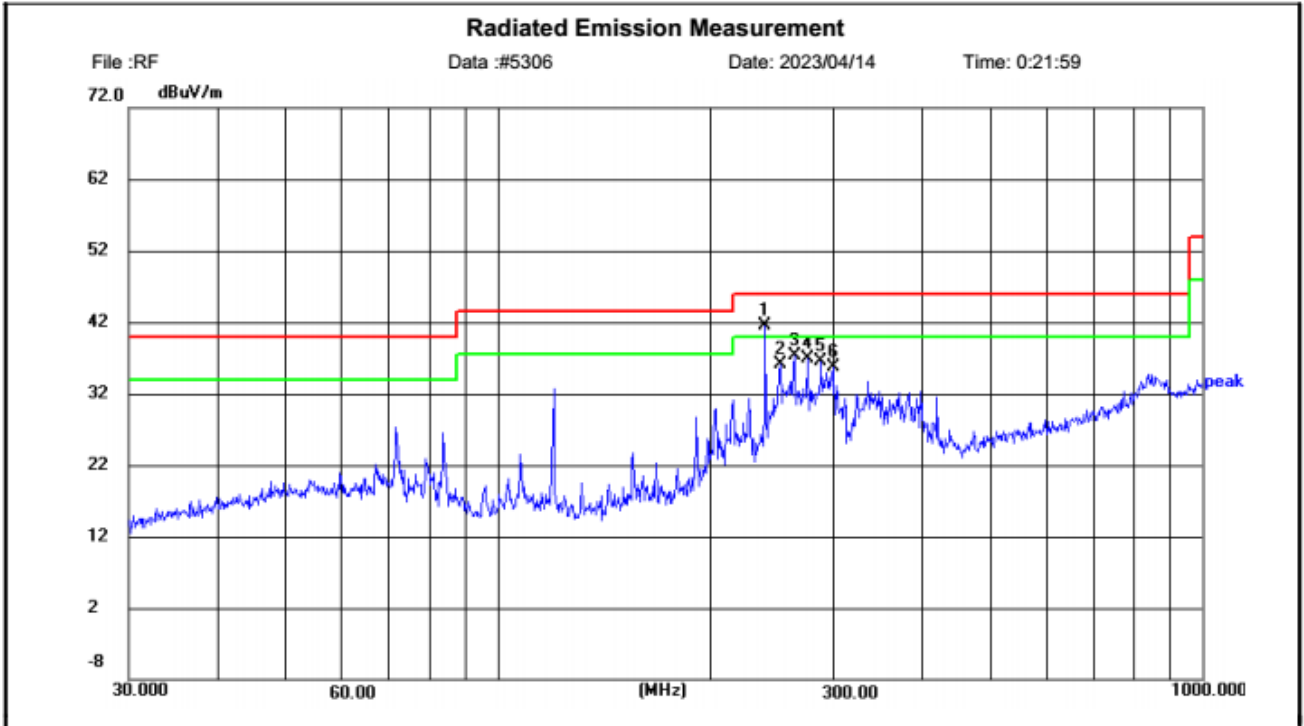

Site LAB Chamber 2  
 Limit: FCC Part15C  
 EUT: /  
 M/N: SD6  
 Mode: BLE2M 2402MHz  
 Note: Edan Instruments, Inc

Polarization: **Horizontal**  
 Power:  
 Distance: 3m

Temperature: 25(C)  
 Humidity: 50 %

No.	Frequency (MHz)	Reading (dBuV)	Factor (dB/m)	Level (dBuV/m)	Limit (dBuV/m)	Margin (dB)	Detector	Height (cm)	Azimuth (deg.)	P/F	Remark
1	239.9873	28.90	12.68	41.58	46.00	4.42	peak	100	165	P	
2	252.0627	23.55	12.58	36.13	46.00	9.87	peak	100	139	P	
3	263.8190	24.52	12.70	37.22	46.00	8.78	peak	100	125	P	
4	275.1570	23.67	13.23	36.90	46.00	9.10	peak	100	145	P	
5	287.9904	22.96	13.56	36.52	46.00	9.48	peak	100	112	P	
6	299.3158	21.99	13.69	35.68	46.00	10.32	peak	100	119	P	



Vertical



Shenzhen CTL Testing Technology Co., Ltd  
 Tel: +86-755-89486194  
 Floor 1-A, Baisha Technology Park, No.3011, Shahexi Road, Nanshan District, She

Radiated Emission Measurement

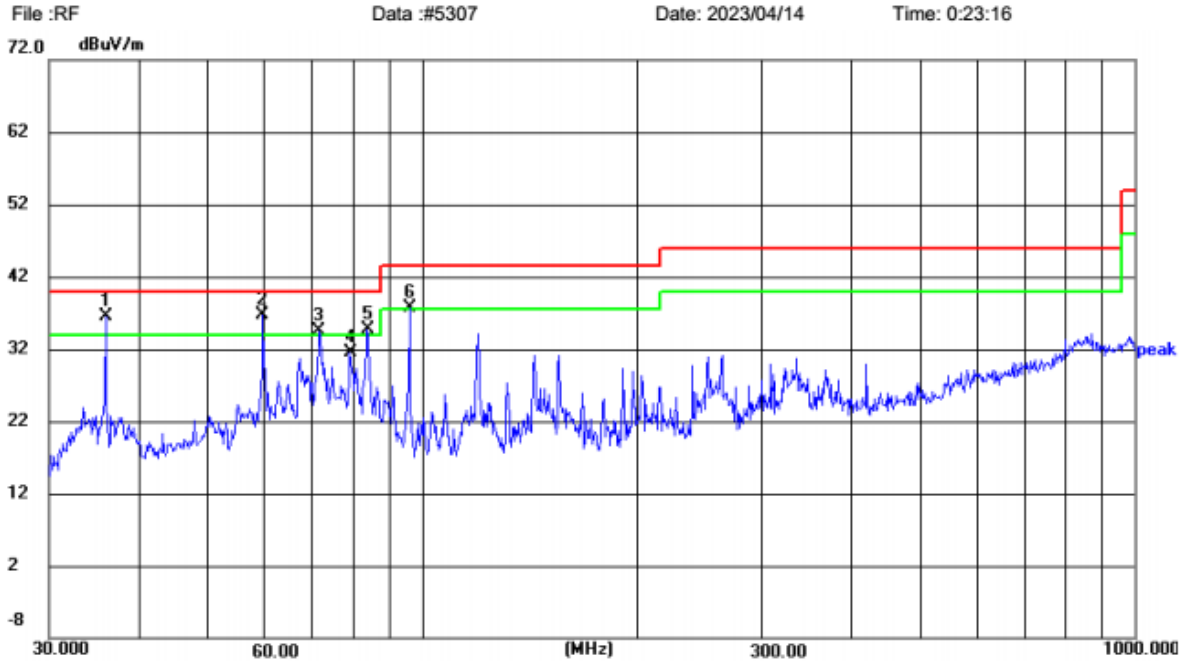

Site LAB Chamber 2 Polarization: **Vertical** Temperature: 25(C)  
 Limit: FCC Part15C Power: Humidity: 50 %  
 EUT: / Distance: 3m  
 M/N: SD6  
 Mode: BLE2M 2402MHz  
 Note: Edan Instruments, Inc

No.	Frequency (MHz)	Reading (dBuV)	Factor (dB/m)	Level (dBuV/m)	Limit (dBuV/m)	Margin (dB)	Detector	Height (cm)	Azimuth (deg.)	P/F	Remark
1	36.0007	23.37	13.06	36.43	40.00	3.57	peak	100	141	P	
2	59.8588	23.18	13.44	36.62	40.00	3.38	peak	100	287	P	
3	71.8320	23.56	10.88	34.44	40.00	5.56	peak	100	175	P	
4	79.2426	21.78	9.65	31.43	40.00	8.57	peak	100	168	P	
5	83.8156	25.30	9.35	34.65	40.00	5.35	peak	100	141	P	
6	96.0986	27.92	9.87	37.79	43.50	5.71	peak	100	254	P	

REMARKS:

1. Level(dBuV/m)=Reading(dBuV)+Factor(dB/m)
2. Factor (dB/m) = Antenna Factor (dB/m)+Cable Factor (dB)-Pre-amplifier Factor
3. Margin= Limit(dBuV/m)- Level(dBuV/m).
4. Other emissions are attenuated 20dB below the limits from 9kHz to 30MHz, so it does not record in report.



Test frequency:

2402MHz

Polarization:

Vertical

**Radiated Emission Measurement**

File :RF-RSE 3

Data :#3731

Date: 2023/04/13

Time: 21:54:46



Site LAB Chamber 2

Polarization: **Vertical**

Temperature: 25(C)

Limit: 74db

Power:

Humidity: 50 %

EUT:

Distance: 3m

M/N: SD6

Mode: BLE1M 2402MHz TX

Note: Edan Instruments, Inc

No.	Frequency (MHz)	Reading (dBuV)	Factor (dB/m)	Level (dBuV/m)	Limit (dBuV/m)	Margin (dB)	Detector	Height (cm)	Azimuth (deg.)	P/F	Remark
1	1102.000	68.54	-28.44	40.10	74.00	33.90	peak	150	360	P	
2	4791.000	61.24	-12.39	48.85	74.00	25.15	peak	150	360	P	
3	7205.000	60.51	-7.01	53.50	74.00	20.50	peak	150	360	P	
4	11557.000	47.68	-3.71	43.97	74.00	30.03	peak	150	360	P	
5	13818.000	49.11	-1.07	48.04	74.00	25.96	peak	150	360	P	
6	17439.000	48.67	2.70	51.37	74.00	22.63	peak	150	360	P	

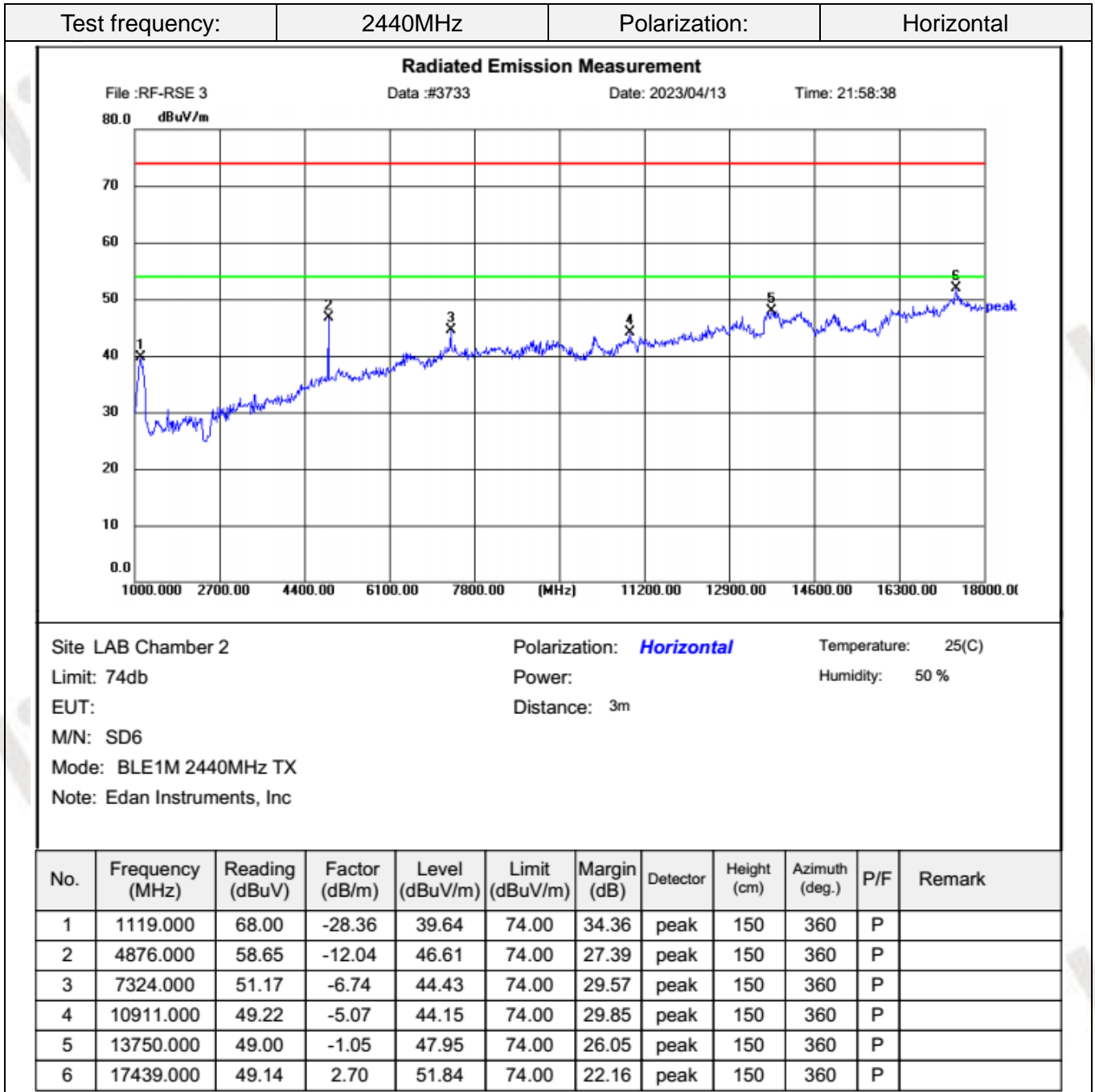

Test frequency:	2440MHz	Polarization:	Vertical
-----------------	---------	---------------	----------

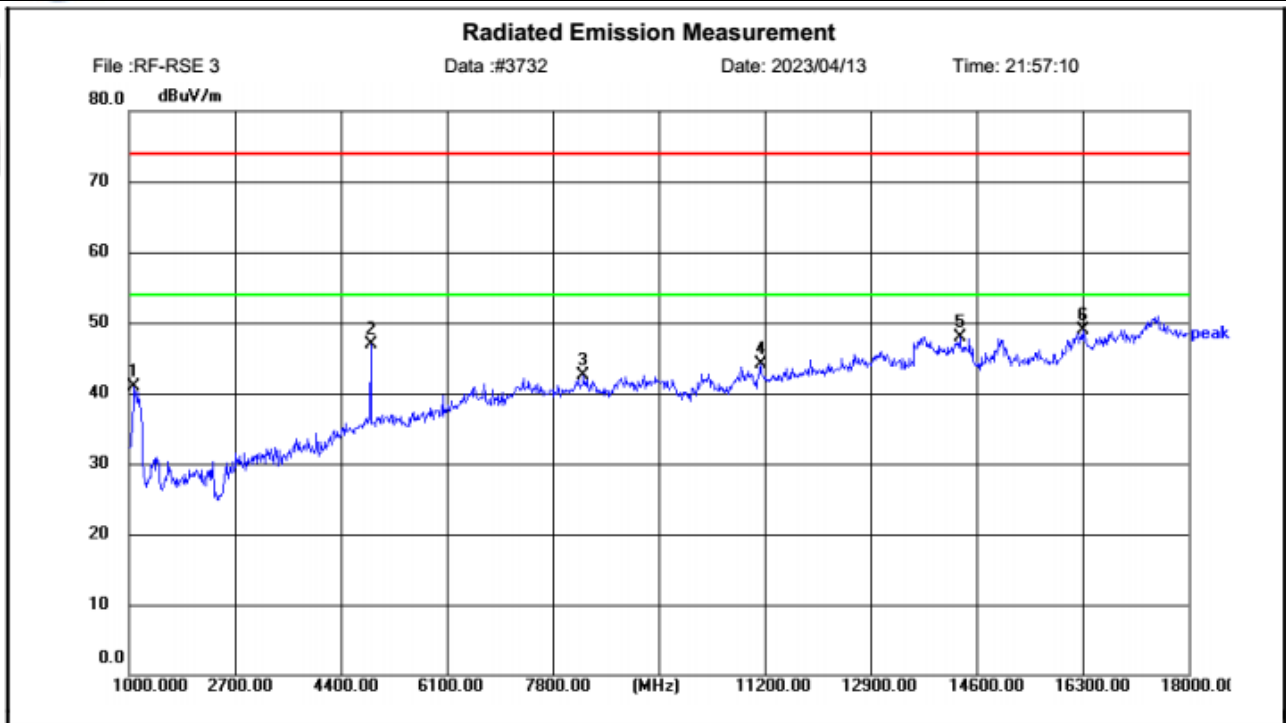

Site LAB Chamber 2      Polarization: **Vertical**      Temperature: 25(C)  
 Limit: 74db      Power:      Humidity: 50 %  
 EUT:      Distance: 3m  
 M/N: SD6  
 Mode: BLE1M 2440MHz TX  
 Note: Edan Instruments, Inc

No.	Frequency (MHz)	Reading (dBuV)	Factor (dB/m)	Level (dBuV/m)	Limit (dBuV/m)	Margin (dB)	Detector	Height (cm)	Azimuth (deg.)	P/F	Remark
1	1085.000	69.49	-28.53	40.96	74.00	33.04	peak	150	0	P	
2	4876.000	59.00	-12.04	46.96	74.00	27.04	peak	150	0	P	
3	8293.000	48.48	-6.07	42.41	74.00	31.59	peak	150	0	P	
4	11132.000	48.84	-4.80	44.04	74.00	29.96	peak	150	0	P	
5	14328.000	49.34	-1.36	47.98	74.00	26.02	peak	150	0	P	
6	16300.000	49.71	-0.87	48.84	74.00	25.16	peak	150	0	P	

Test frequency:

2480MHz

Polarization:

Horizontal

**Radiated Emission Measurement**

File :RF-RSE 3

Data :#3734

Date: 2023/04/13

Time: 22:00:57

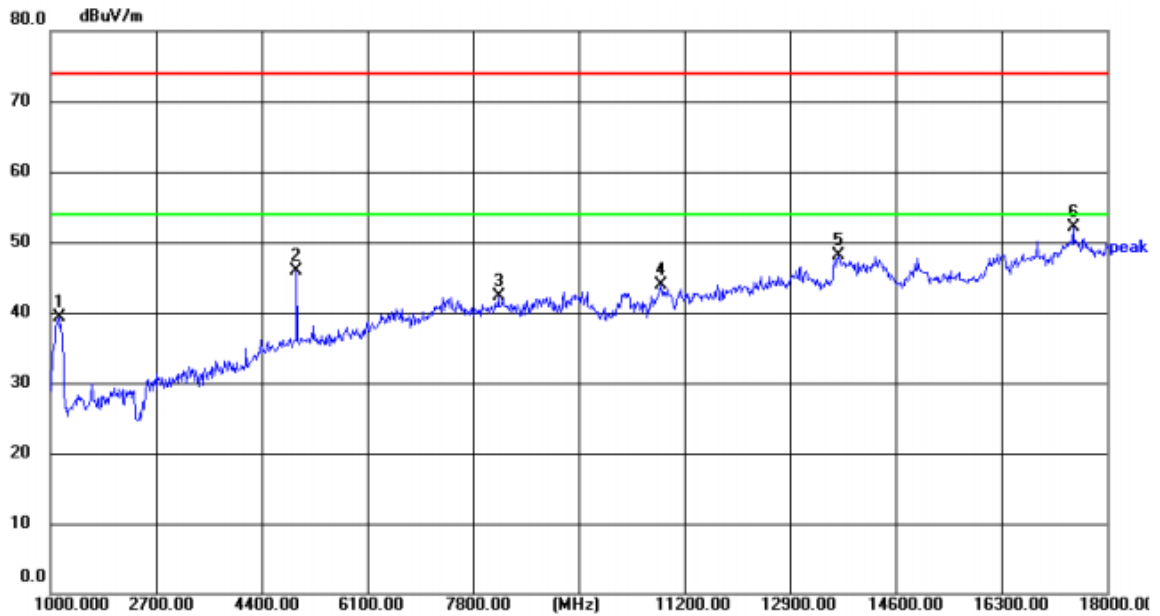

Site LAB Chamber 2

Polarization: **Horizontal**

Temperature: 25(C)

Limit: 74db

Power:

Humidity: 50 %

EUT:

Distance: 3m

M/N: SD6

Mode: BLE1M 2480MHz TX

Note: Edan Instruments, Inc

No.	Frequency (MHz)	Reading (dBuV)	Factor (dB/m)	Level (dBuV/m)	Limit (dBuV/m)	Margin (dB)	Detector	Height (cm)	Azimuth (deg.)	P/F	Remark
1	1136.000	67.63	-28.29	39.34	74.00	34.66	peak	150	0	P	
2	4961.000	57.57	-11.71	45.86	74.00	28.14	peak	150	0	P	
3	8208.000	48.32	-6.08	42.24	74.00	31.76	peak	150	0	P	
4	10826.000	48.87	-4.97	43.90	74.00	30.10	peak	150	0	P	
5	13682.000	49.17	-1.01	48.16	74.00	25.84	peak	150	0	P	
6	17456.000	49.36	2.72	52.08	74.00	21.92	peak	150	0	P	

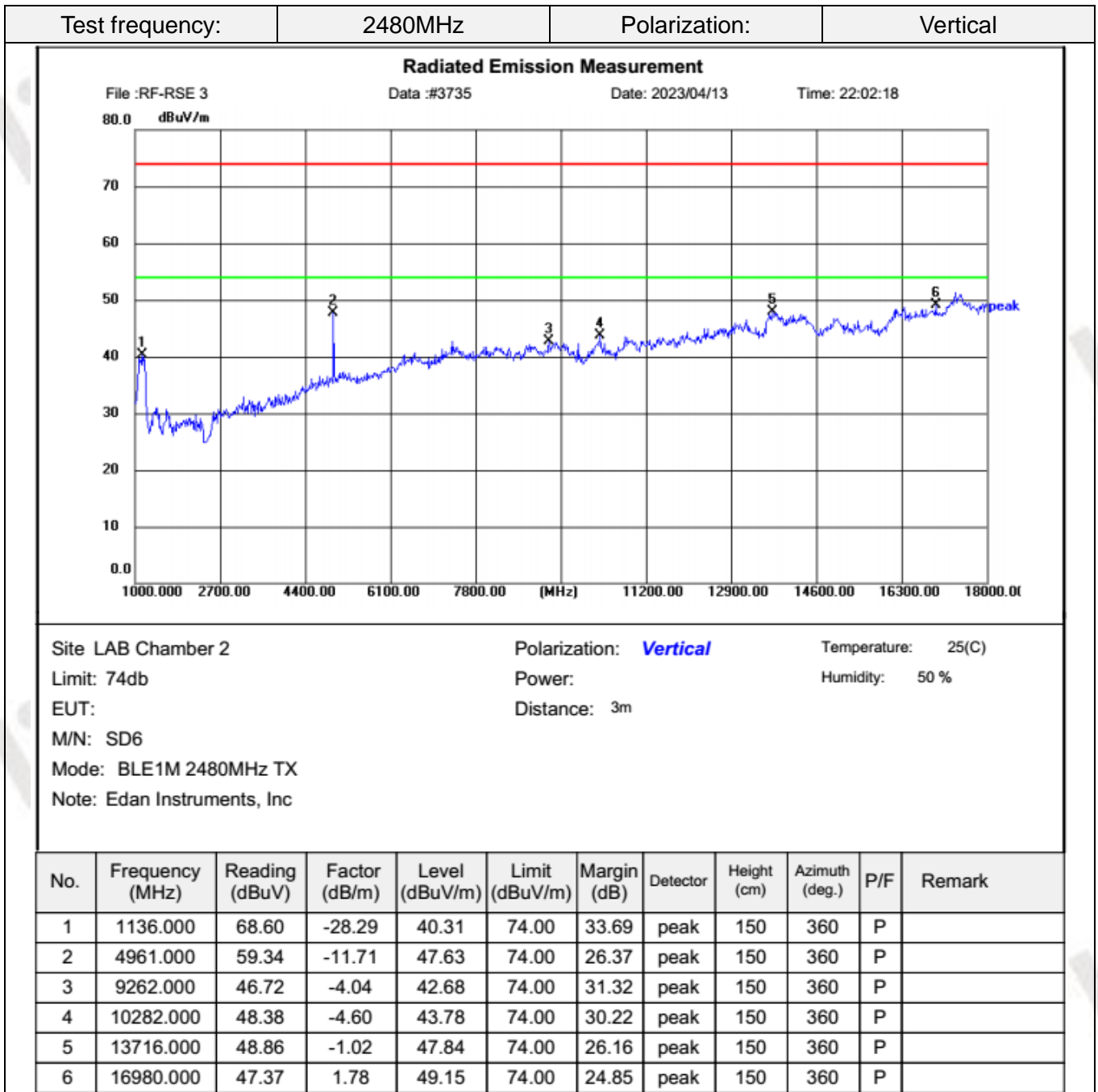

REMARKS:

1. Level(dBuV/m)=Reading(dBuV)+Factor(dB/m)
2. Factor (dB/m) = Antenna Factor (dB/m)+Cable Factor (dB)-Pre-amplifier Factor
3. Margin= Limit(dBuV/m)- Level(dBuV/m).
4. RBW 1MHz VBW 3MHz Peak detector is for PK value; RBW 1MHz VBW 10Hz Peak detector is for AV value.
5. 18GHz-26GHz not recorded for no spurious point have a margin of less than 6 dB with respect to the limits.

**Results of Band Edges Test (Radiated)**

Test frequency:	2402MHz	Polarization:	Horizontal
-----------------	---------	---------------	------------

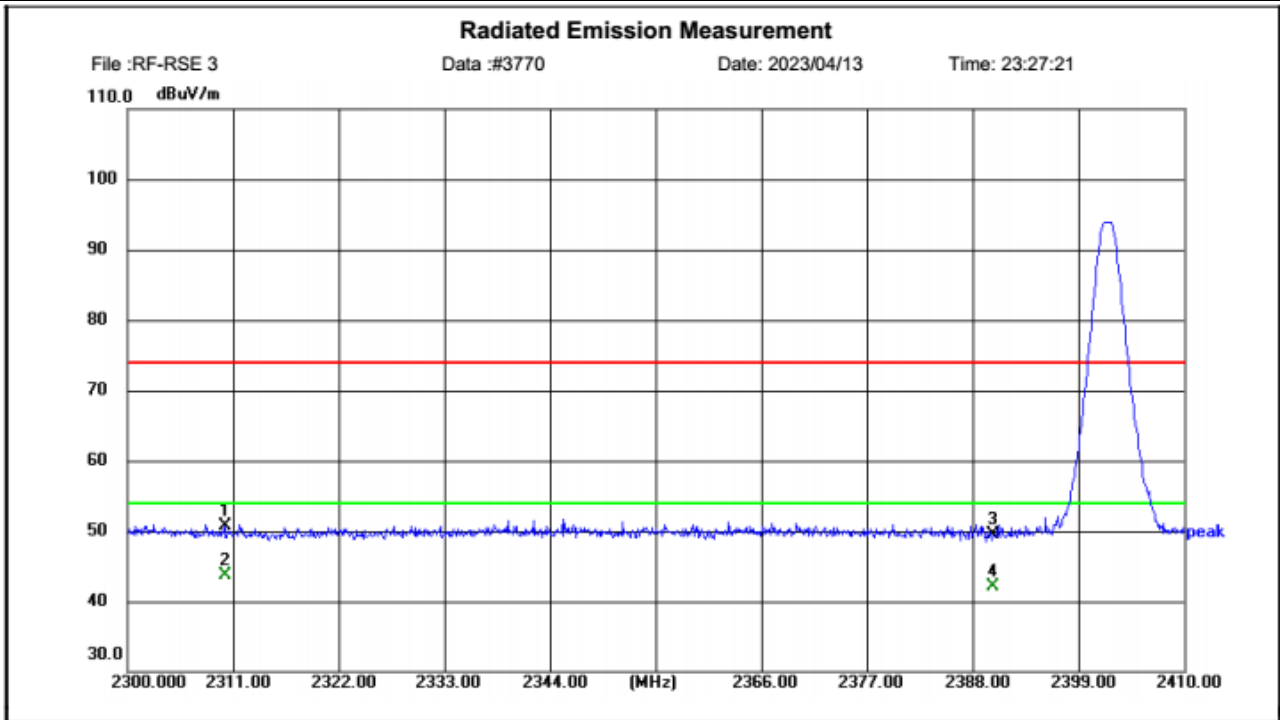

Site LAB Chamber 2  
 Limit: 74db  
 EUT:  
 M/N: SD6  
 Mode: BLE1M 2402MHz TX  
 Note: Edan Instruments, Inc

Polarization: **Horizontal**  
 Power:  
 Distance: 3m

Temperature: 25(C)  
 Humidity: 50 %

No.	Frequency (MHz)	Reading (dBuV)	Factor (dB/m)	Level (dBuV/m)	Limit (dBuV/m)	Margin (dB)	Detector	Height (cm)	Azimuth (deg.)	P/F	Remark
1	2310.120	42.72	8.00	50.72	74.00	23.28	peak	150	360	P	
2	2310.120	35.69	8.00	43.69	54.00	10.31	AVG	150	0	P	
3	2390.090	41.41	8.13	49.54	74.00	24.46	peak	150	360	P	
4	2390.090	34.00	8.13	42.13	54.00	11.87	AVG	150	0	P	



Test frequency:	2402MHz	Polarization:	Vertical
-----------------	---------	---------------	----------

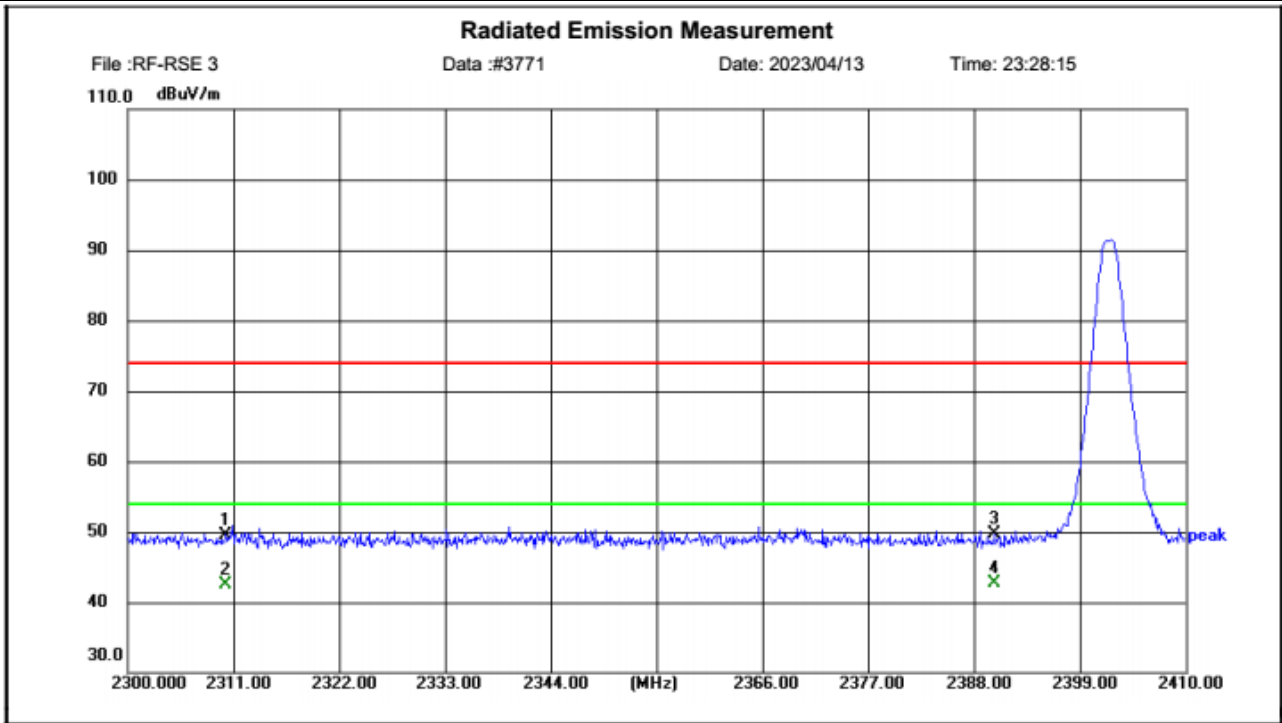

Site LAB Chamber 2      Polarization: **Vertical**      Temperature: 25(C)  
 Limit: 74db      Power:      Humidity: 50 %  
 EUT:      Distance: 3m  
 M/N: SD6  
 Mode: BLE1M 2402MHz TX  
 Note: Edan Instruments, Inc

No.	Frequency (MHz)	Reading (dBuV)	Factor (dB/m)	Level (dBuV/m)	Limit (dBuV/m)	Margin (dB)	Detector	Height (cm)	Azimuth (deg.)	P/F	Remark
1	2310.120	41.41	8.00	49.41	74.00	24.59	peak	150	360	P	
2	2310.120	34.52	8.00	42.52	54.00	11.48	AVG	150	0	P	
3	2390.090	41.60	8.13	49.73	74.00	24.27	peak	150	360	P	
4	2390.090	34.55	8.13	42.68	54.00	11.32	AVG	150	0	P	

Test frequency:	2480MHz	Polarization:	Horizontal
-----------------	---------	---------------	------------

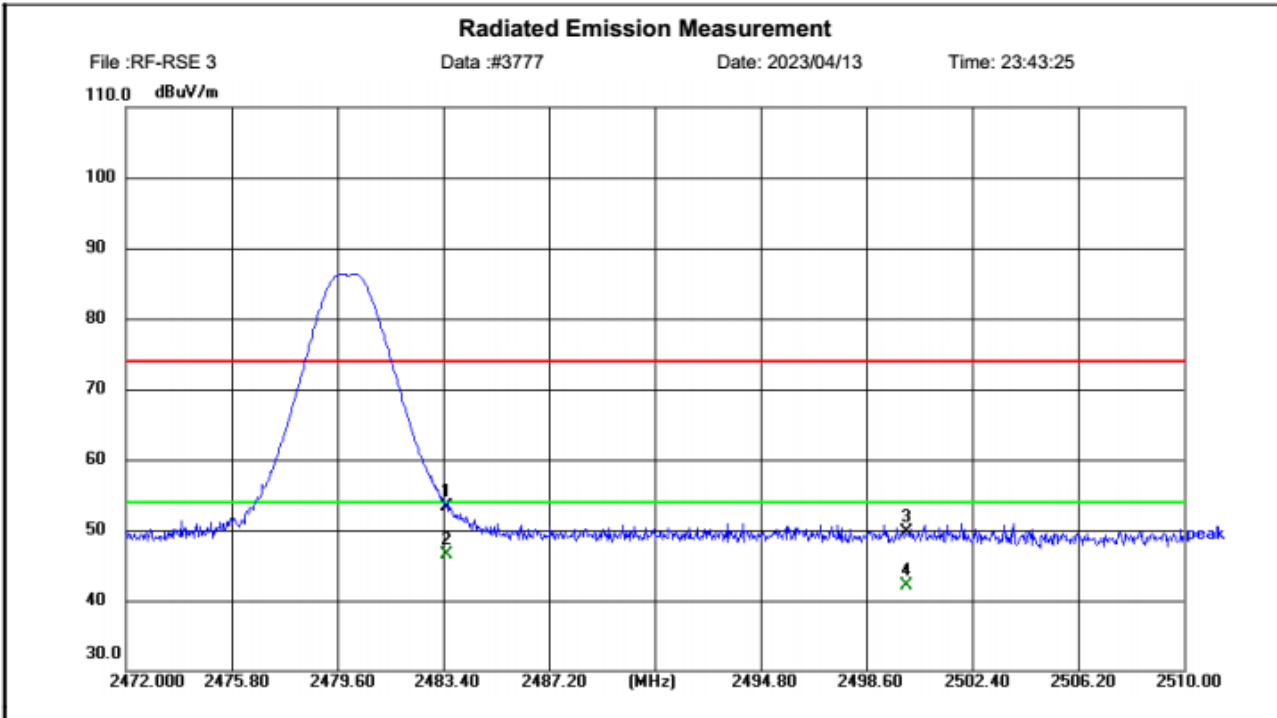

Site LAB Chamber 2	Polarization: <b>Horizontal</b>	Temperature: 25(C)
Limit: 74db	Power:	Humidity: 50 %
EUT:	Distance: 3m	
M/N: SD6		
Mode: BLE1M 2480MHz TX		
Note: Edan Instruments, Inc		

No.	Frequency (MHz)	Reading (dBuV)	Factor (dB/m)	Level (dBuV/m)	Limit (dBuV/m)	Margin (dB)	Detector	Height (cm)	Azimuth (deg.)	P/F	Remark
1	2483.514	44.99	8.35	53.34	74.00	20.66	peak	150	360	P	
2	2483.514	38.22	8.35	46.57	54.00	7.43	AVG	150	0	P	
3	2500.006	41.25	8.43	49.68	74.00	24.32	peak	150	360	P	
4	2500.006	33.69	8.43	42.12	54.00	11.88	AVG	150	0	P	

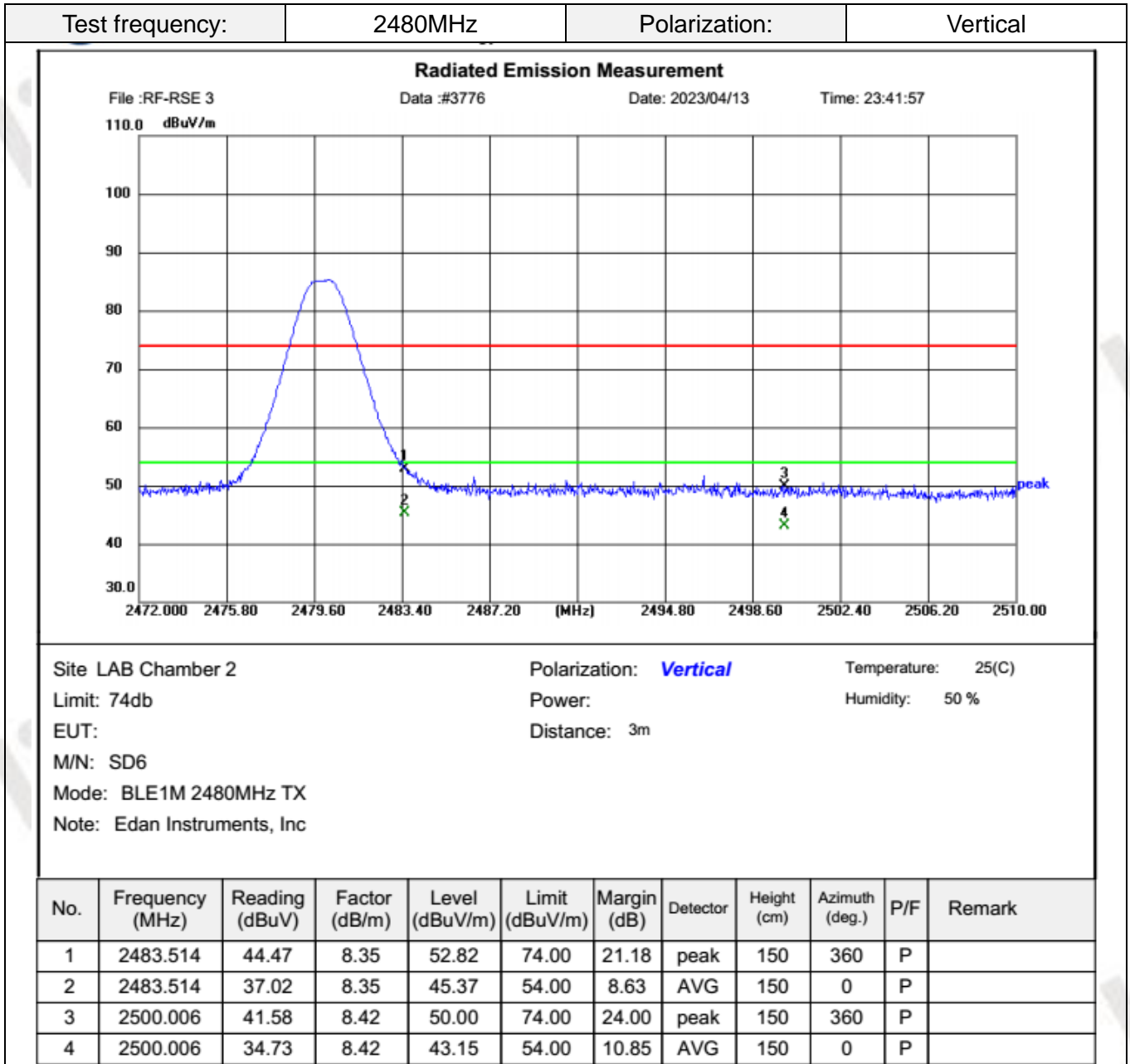

REMARKS:

1. Level(dBuV/m)=Reading(dBuV)+Factor(dB/m)
2. Factor (dB/m) = Antenna Factor (dB/m)+Cable Factor (dB)-Pre-amplifier Factor
3. Margin= Limit(dBuV/m)- Level(dBuV/m).
4. RBW 1MHz VBW 3MHz Peak detector is for PK value; RBW 1MHz VBW 10Hz Peak detector is for AV value.

### 3.3. Maximum Conducted Output Power

#### Limit

The Maximum Peak Output Power Measurement is 30dBm.

#### Test Procedure

Remove the antenna from the EUT and then connect a low loss RF cable from the antenna port to the Spectrum Analyzer.

#### Test Configuration



#### Test Results

Raw data reference to Section 3 from Appendix for BLE.

### 3.4. Power Spectral Density

#### Limit

For digitally modulated systems, the power spectral density conducted from the intentional radiator to the antenna shall not be greater than 8 dBm in any 3 kHz band during any time interval of continuous transmission.

#### Test Procedure

1. Use this procedure when the maximum peak conducted output power in the fundamental emission is used to demonstrate compliance.
2. Set the RBW  $\geq$  3 kHz.
3. Set the VBW  $\geq$  3 $\times$  RBW.
4. Set the span to 1.5 times the DTS channel bandwidth.
5. Detector = peak.
6. Sweep time = auto couple.
7. Trace mode = max hold.
8. Allow trace to fully stabilize.
9. Use the peak marker function to determine the maximum power level.
10. If measured value exceeds limit, reduce RBW (no less than 3 kHz) and repeat.
11. The resulting peak PSD level must be 8dBm.

#### Test Configuration

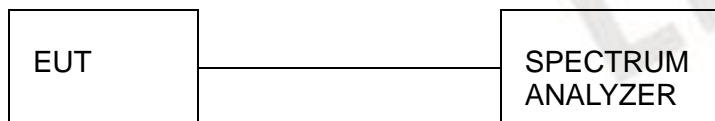

#### Test Results

Raw data reference to Section 4 from Appendix for BLE.

### 3.5. 6dB Bandwidth

#### Limit

For digital modulation systems, the minimum 6 dB bandwidth shall be at least 500 kHz

#### Test Procedure

The transmitter output was connected to the spectrum analyzer through an attenuator. The bandwidth of the fundamental frequency was measured by spectrum analyzer with 100 KHz RBW and 300 KHz VBW. The 6dB bandwidth is defined as the total spectrum the power of which is higher than peak power minus 6dB.

#### Test Configuration



#### Test Results

Raw data reference to Section 2 from Appendix for BLE.

### 3.6. Out-of-band Emissions

#### Limit

In any 100 kHz bandwidth outside the frequency band in which the spread spectrum or digitally modulated intentional radiator is operating, the radio frequency power that is produced by the intentional radiator shall be at least 20 dB below that in the 100 kHz bandwidth within the band that contains the highest level of the desired power, based on either an RF conducted or a radiated measurement, provided the transmitter demonstrates compliance with the peak conducted power limits. If the transmitter complies with the conducted power limits based on the use of RMS averaging over a time interval, as permitted under paragraph (b)(3) of this section, the attenuation required under this paragraph shall be 30 dB instead of 20 dB. Attenuation below the general limits specified in §15.209(a) is not required.

#### Test Procedure

Connect the transmitter output to spectrum analyzer using a low loss RF cable, and set the spectrum analyzer to RBW=100 kHz, VBW= 300 kHz, peak detector, and max hold. Measurements utilizing these settings are made of the in-band reference level, bandedge and out-of-band emissions.

#### Test Configuration

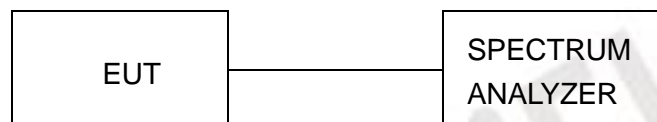

#### Test Results

Raw data reference to Section 5 from Appendix for BLE.

### 3.7. Antenna Requirement

#### Standard Applicable

**For intentional device, according to FCC 47 CFR Section 15.203:**

An intentional radiator shall be designed to ensure that no antenna other than that furnished by the responsible party shall be used with the device. The use of a permanently attached antenna or of an antenna that uses a unique coupling to the intentional radiator, the manufacturer may design the unit so that a broken antenna can be replaced by the user, but the use of a standard antenna jack or electrical connector is prohibited

#### **FCC CFR Title 47 Part 15 Subpart C Section 15.247(b) (4):**

(4) The conducted output power limit specified in paragraph (b) of this section is based on the use of antennas with directional gains that do not exceed 6 dBi. Except as shown in paragraph (c) of this section, if transmitting antennas of directional gain greater than 6 dBi are used, the conducted output power from the intentional radiator shall be reduced below the stated values in paragraphs (b)(1), (b)(2), and (b)(3) of this section, as appropriate, by the amount in dB that the directional gain of the antenna exceeds 6 dBi.

#### **Test Result:**

The maximum gain of antenna was 2.63dBi

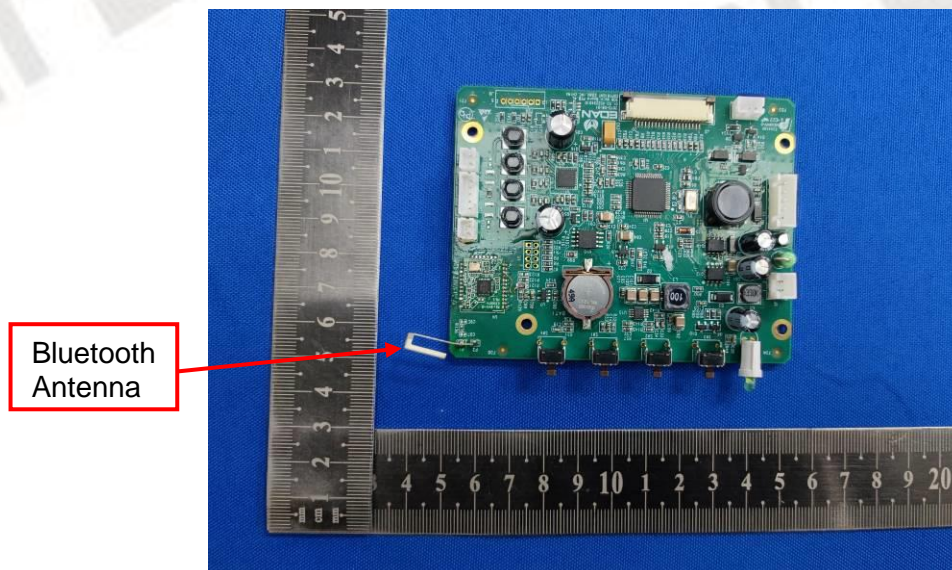



### 4. Test Setup Photos of the EUT



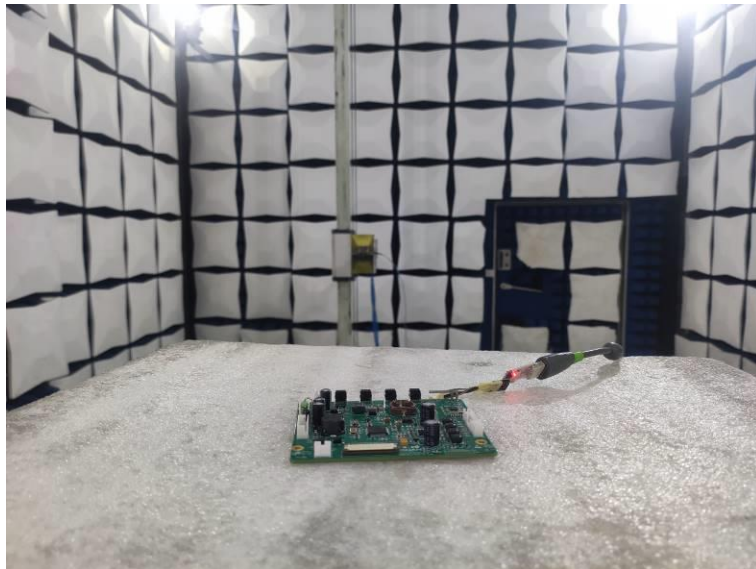

### 5. Photos of the EUT

Bluetooth  
Antenna

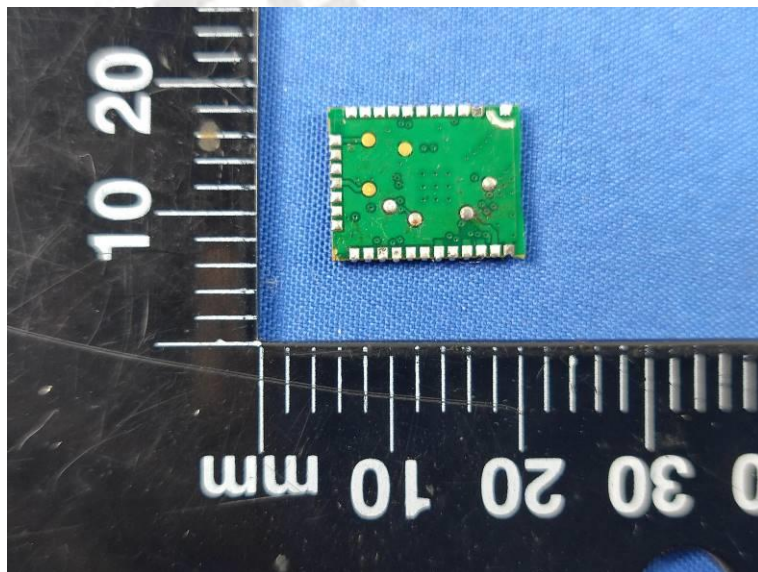
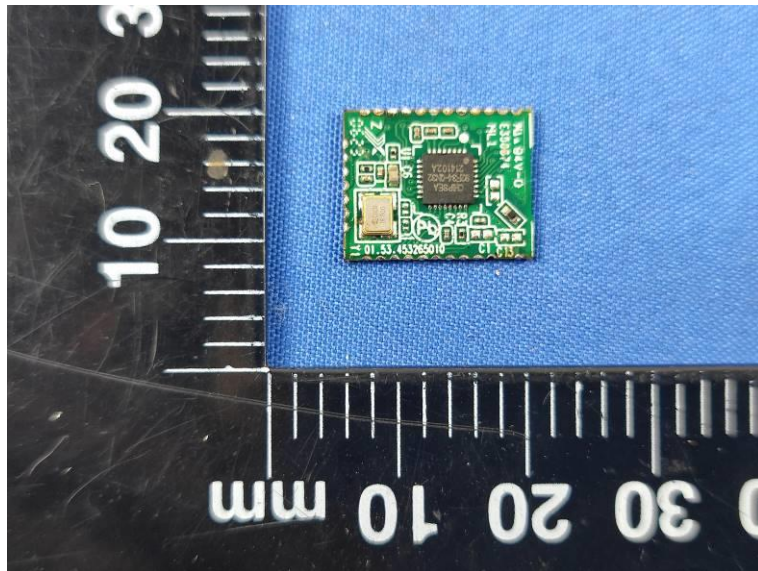
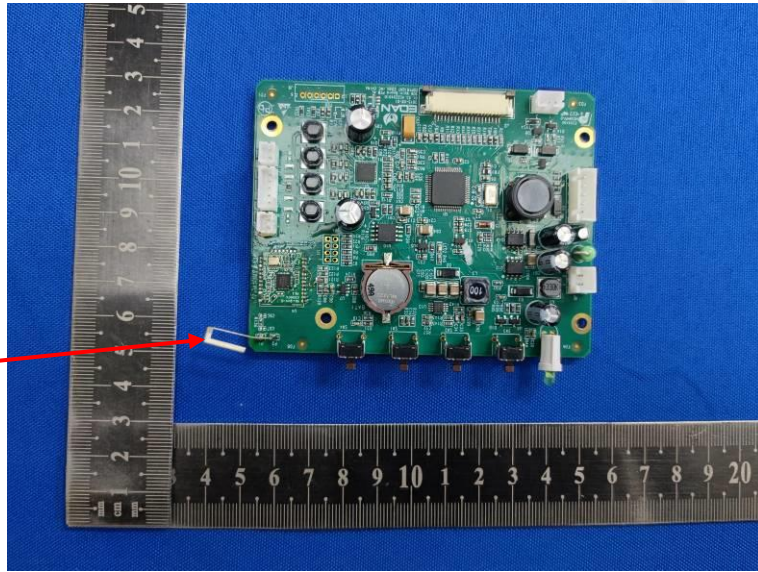



\*\*\*\*\* End of Report \*\*\*\*\*