

# Acclarix LX9 Series

Diagnostic Ultrasound System  
Version 1.0

# User Manual

Basic Volume



## ***About This Manual***

P/N:01.54.458126

MPN: 01.54.458126010

Release Date: March, 2019

© Copyright EDAN INSTRUMENTS, INC. 2019

This User Manual applies to 1.0X releases for Acclarix LX9 series Diagnostic Ultrasound Systems including Acclarix LX9, Acclarix LX9 Exp, Acclarix LX9 Super, Acclarix LX85 and Acclarix LX88. See Appendix A.9 for the difference between these models.

This User Manual Basic Volume together with the User Manual Advanced Volume (P/N: 01.54.458127) contain necessary and sufficient information to use the Acclarix LX9 Series Diagnostic Ultrasound Systems safely for the intended purposes and approved clinical applications.

Please read and make sure you understand all of the instructions in this manual prior to using the system. Disregarding instructions, particularly warnings and cautions, is considered abnormal use. Not all measurements and features are available for all system models and configurations. This manual is based on the complete set of transducers and features available. Therefore, some of the contents may not apply to your product. If you have any questions, please contact your local EDAN representative. The pictures and interfaces in this manual are for reference only.

## ***Conventions***

In this manual, the following conventions are used to describe the system for better understanding:

- ***Bold***: bold texts indicate keys or items on main screen or touch screen.
- ***<Bold>***: bold texts in angular brackets indicate buttons, knobs and other controls on the console or on the keyboard.
- ***->***: Arrow indicates operations following the path.

## ***Contact Information:***

For sales or service information please contact your local distributor or the EDAN service department at: [support@edan.com.cn](mailto:support@edan.com.cn)

# Contents

<b>1</b>	<b>Introduction</b>	<b>1</b>
1.1	Intended Use/ Indications for Use	1
1.2	Contra-indications	1
1.3	Device Description	1
<b>2</b>	<b>Safety</b>	<b>2</b>
2.1	Warnings	2
2.2	Cautions	4
2.3	Labeling Symbols	7
<b>3</b>	<b>Getting Started</b>	<b>11</b>
3.1	System Configuration	11
3.2	System Overview	13
3.2.1.	Main Unit	13
3.2.2.	Control Panel	17
3.2.3.	Screen Layout	21
3.2.1.	Touch Screen	24
3.2.4.	Trackball	26
3.3	System Preparation	27
3.3.1.	Battery Use	27
3.3.2.	AC Power Use	29
3.3.3.	Transducer Connection	29
3.3.4.	Powering on/ off	30
3.4	Monitor Position Adjustment	31
3.5	Control Panel Position Adjustment	34
<b>4</b>	<b>Exam Operation</b>	<b>36</b>
4.1	How to Start an Exam	36
4.2	How to End an Exam	37
4.3	How to Restart an Exam	37
4.4	The Patient Information Page	37
4.5	Modality Worklist	39
<b>5</b>	<b>Imaging</b>	<b>41</b>
5.1	B-mode	41
5.1.1.	Using B-mode	41
5.1.2.	B-mode Image Optimization	41
5.2	Color Mode	45
5.2.1.	Color Mode Variants	45
5.2.2.	Using Color Mode	45
5.2.3.	Color Image Optimization	45
5.3	PW Mode	48
5.3.1.	Using PW Mode	48

5.3.2. PW Image Optimization.....	48
5.3.3. HPRF .....	51
5.4 CW Mode .....	51
5.4.1. Using CW Mode .....	51
5.4.2. CW Image Optimization.....	51
5.5 M Mode .....	53
5.5.1. Using M Mode .....	53
5.5.2. M-mode Image Optimization .....	53
5.6 Anatomic M Mode.....	55
5.6.1. Using Anatomic M Mode.....	55
5.6.2. Anatomic M Image Optimization.....	55
5.7 Color M Mode.....	56
5.7.1. Using Color M Mode.....	56
5.7.2. Color M Image Optimization .....	56
5.8 TDI Mode.....	57
5.8.1. TDI Mode Operations .....	57
5.8.2. TDI Touch Screen Controls .....	57
5.9 3D/4D Mode .....	58
5.9.1. Pre-3D/Pre-4D.....	58
5.9.2. 3D Volume Sweeping .....	59
5.9.3. 3D Image Review .....	60
5.9.4. 4D Volume Acquisition.....	64
5.9.5. 4D Live Volume .....	64
5.9.6. 4D Cine .....	65
5.9.7. Knobs and Buttons on Control Panel .....	66
5.10 Panorama.....	67
5.11 Elastography.....	68
5.11.1. Using Elastography Mode.....	68
5.11.2. Elastography Image Optimization .....	69
5.12 Contrast Imaging .....	70
5.12.1. Using Contrast Imaging .....	71
5.12.2. Touch Screen Controls .....	71
5.12.3. Time Intensity Curve (TIC) Analysis .....	73
<b>5.13 ECG.....</b>	<b>76</b>
5.13.1. ECG Touch Screen Controls .....	77
5.13.2. ECG Basic Operations .....	77
5.13.3. ECG Review.....	78
<b>6 Transducers and Biopsy .....</b>	<b>79</b>
6.1 Transducer Model.....	79
6.2 Using Transducers.....	81

6.3 Transducer Cleaning and Disinfecting .....	84
6.3.1. Cleaning .....	84
6.3.2. Disinfection .....	84
6.3.3. Sterilization .....	87
6.3.4. Storage .....	87
6.4 Needle Biopsy Guide .....	88
6.4.1. Installing Needle Guide Bracket .....	88
6.4.2. Activating Needle Guide Function .....	94
6.4.3. To Adjust the Needle Guide Line .....	94
6.5 Needle Visualization .....	95
6.6 Center Line .....	96
6.7 Needle Guide Bracket Cleaning and Sterilization .....	96
6.7.1. Cleaning .....	97
6.7.2. Sterilization .....	97
6.7.3. Storage .....	97
<b>7 Features .....</b>	<b>98</b>
7.1 Comments .....	98
7.2 Body Mark .....	100
7.3 Split Display .....	101
7.3.1. Dual Imaging .....	101
7.3.2. Quad Imaging .....	101
7.4 Zoom .....	102
7.4.1. Pan Zoom .....	102
7.4.2. Spot Zoom .....	102
<b>8 Measurements and Reports .....</b>	<b>103</b>
8.1 Generic Measurements .....	107
8.1.1. B-mode Generic Measurements .....	107
8.1.2. M-mode Generic Measurements .....	110
8.1.3. Strip Doppler Generic Measurements .....	112
8.2 Application Measurements .....	116
8.2.1. Abdomen Measurements .....	117
8.2.2. Gynecology Measurements .....	118
8.2.3. Obstetrics Measurements .....	119
8.2.4. Cardiac Measurements .....	123
8.2.5. Small Parts Measurements .....	127
8.2.6. Urology Measurements .....	128
8.2.7. Vascular Measurements .....	129
8.2.8. Pediatric Measurements .....	132
8.3 Worksheet and Report .....	134
8.3.1. Worksheet .....	134

8.3.2. Report .....	139
8.4 Measurement Accuracy .....	140
<b>9 Exam Data Management.....</b>	<b>141</b>
9.1 Storing Images .....	141
9.2 Reviewing Images .....	142
9.3 Exam Database .....	143
9.4 Archiving Studies .....	146
9.5 Structured Report .....	146
<b>10 Presets .....</b>	<b>147</b>
10.1 Preset Organization .....	147
10.2 Selecting a Preset .....	148
10.3 Storing and Editing a Preset.....	148
10.3.1. Exam Preset.....	149
10.3.2. Comment Preset .....	151
10.3.3. Body Mark Preset.....	152
10.4 Measure Presets .....	154
10.4.1. General Set-up .....	154
10.4.2. Application Parameter .....	155
10.4.3. Measure Presets .....	156
10.4.4. Report Set-up .....	157
<b>11 Utilities .....</b>	<b>158</b>
11.1 System Set-up .....	158
11.1.1. General Set-up .....	158
11.1.2. Patient Set-up.....	160
11.1.3. Store/Print Set-up .....	161
11.1.4. Miscellaneous Set-up .....	162
11.1.5. User Set-up .....	163
11.2 Connectivity .....	164
11.2.1. TCP/IP .....	165
11.2.2. DICOM.....	166
11.2.3. Network Store .....	170
11.3 Maintenance .....	171
11.3.1. License .....	171
11.3.2. Version.....	171
11.3.3. Demo .....	172
11.3.4. Export/Import .....	172
11.4 Screen Adjust.....	173
<b>12 In Between Exams .....</b>	<b>174</b>
12.1 Unpacking .....	174
12.2 Transport .....	174

12.3 Storage.....	174
<b>13 Troubleshooting and Maintenance.....</b>	<b>175</b>
13.1 Daily Checklist.....	175
13.2 Troubleshooting.....	175
13.3 Cleaning and Disinfecting the System.....	176
13.3.1. Cleaning and Disinfecting the System Surface.....	177
13.3.2. Cleaning and Disinfecting the ECG Cable.....	179
13.4 Maintenance.....	180
<b>Appendix A Specifications .....</b>	<b>181</b>
A.1 Electrical Safety Classifications.....	181
A.2 Power Supply .....	181
A.3 Battery.....	181
A.4 Machine Specifications.....	182
A.5 Display Specifications .....	182
A.6 Technical Specifications .....	182
A.7 Operating, Storage and Transportation Environment .....	184
A.7.1 Operating Environment.....	184
A.7.2 Storage and Transportation Environment .....	184
A.8 Transducer Specifications .....	184
A.9 Configuration Difference.....	185
<b>Appendix B Ultrasound Intensity and Safety.....</b>	<b>186</b>
B.1 Ultrasound in Medicine.....	186
B.2 Ultrasound Safety and the ALARA Principle.....	186
B.3 Explanation of MI/TI .....	187
B.3.1 MI (Mechanical Index) .....	187
B.3.2 TI (Thermal Index) .....	187
B.3.3 Display of MI/TI.....	188
B.4 Acoustic Output.....	188
B.4.1 Factors that Contribute to Uncertainty in the Output Display .....	188
B.4.2 Differences between Actual and Displayed MI/TI.....	188
B.4.3 Measurement Uncertainty.....	188
B.4.4 Acoustic Power Default Settings.....	189
B.5 Operator Control Features.....	189
B.6 Prudent Use Statement .....	189
B.7 References for Acoustic Output and Safety.....	189
B.8 Transducer Acoustic Output Data.....	190
<b>Appendix C Order List .....</b>	<b>191</b>
<b>Appendix D EMC Information.....</b>	<b>193</b>
<b>Appendix E Ultrasound Gel Warmer.....</b>	<b>198</b>

# **1 Introduction**

## **1.1 Intended Use/ Indications for Use**

The Acclarix LX9 series Diagnostic Ultrasound System is intended for use by a qualified physician or allied health professional for ultrasound evaluations in hospitals and clinics. Clinical applications include:

- Abdominal
- Gynecology
- Obstetric
- Cardiac
- Small parts
- Urology
- Musculoskeletal
- Peripheral vascular
- Intra-operative
- Pediatric
- Neonatal
- Adult Cephalic

## **1.2 Contra-indications**

The Acclarix LX9 series Diagnostic Ultrasound System is not intended for ophthalmic use or any use causing the acoustic beam to pass through the eye.

## **1.3 Device Description**

The Diagnostic Ultrasound System consists of a main system and associated ultrasound transducers. The system circuitry generates an electronic voltage pulse, which is transmitted to the transducer. In the transducer, a piezoelectric array converts the electronic pulse into an ultrasonic pressure wave. When coupled to the body, the pressure wave transmits through body tissues. The waves are then reflected within the body and detected by the transducer, which then converts the waves back to an electrical signal. The system then analyzes the returned signals and generates an ultrasound image or spectral Doppler display.

The Diagnostic Ultrasound System provides the operator the ability to measure anatomical structures, and offers analysis packages that provide information used by competent health care professionals to make a diagnosis.

The system's user interface provides both hard keys for functions frequently used throughout an exam and touch screen controls for mode-specific functions.



## 2 Safety

Throughout this document the following terms are used:

- **Warning:** Advises against certain actions or situations that could result in personal injury or death.
- **Caution:** Advises against actions or situations that could damage equipment, produce inaccurate data, or invalidate a procedure.
- **Note:** Provides useful information regarding a function or a procedure.

Please read all warnings and cautions prior to using the system. For your convenience, all warnings and cautions are provided in this section, but may be duplicated elsewhere in this document in the context of the instructions for use.

### 2.1 Warnings

- Only use Edan supplied power cord.
- Only use Edan supplied battery. Read and understand the battery installation instructions prior to changing the battery.
- Only use Edan supplied transducer. Use of other transducers may result in electric shock or system malfunction.
- Only use a hospital grade, grounded, power outlet and plug. Do not use with an ungrounded outlet.
- The system is ordinary equipment (Sealed equipment without liquid proof). The transducers (not including the transducer connector) are IPX7 certified. The footswitch is IP68 certified. Do not immerse or expose any of the parts to extended moisture. Splash resistance does not extend to transducer connectors. Please keep connectors dry.
- Do not use in a wet environment or when the relative humidity exceeds 95%.
- Do not reverse the positive and negative poles when installing the battery.
- Do not use the battery near heat sources or when the ambient temperature is over 40°C. Do not heat or dispose of in fire.
- Do not destroy the battery; do not pierce or cause a strong impact to the battery.
- Do not touch the connector pins on the transducer port.
- Parts and accessories used must meet the requirements of the applicable IEC/EN60601 series safety standards, and/or the system configuration must meet the requirements of the IEC/EN60601-1.
- Use protective barriers (gloves and transducer sheaths) whenever possible. Follow sterile procedures when appropriate. Thoroughly clean Transducers and reusable accessories after each patient examination and disinfect or sterilize as needed. Refer to transducer use and care instructions. Follow all infection control policies established by your office, department or institution as they apply to personnel and equipment.
- Not intended for Ophthalmic use.
- If a sterile transducer cover becomes compromised during an intra-operative application involving a patient with transmissible spongiform encephalopathy, such as Creutzfeldt-Jakob disease, follow the guidelines of the U.S. Disease Control Center and this document from the World Health Organization: WHO/CDS/APH/2000/3, WHO Infection Control Guidelines for

Transmissible Spongiform Encephalopathies. The transducers for your system cannot be decontaminated using a heat process.

- Contact with natural rubber latex may lead to a severe anaphylactic reaction in persons sensitive to the natural latex protein. Sensitive users and patients must avoid contact with these items. EDAN strongly recommends that health-care professionals identify their latex-sensitive patients, and refer to the March 29, 1991 Medical Alert on Latex products. Be prepared to treat allergic reactions immediately.
- Improper operation may cause the internal lithium battery (hereinafter called battery) to become hot, ignited or possibly explode, and it may lead to decreased battery capacity. It is necessary to read the user manual instructions and warning messages carefully.
- Do not touch accessible contacts of electrical equipment and the patient simultaneously.
- This device is not suitable for intra-cardiac use or direct cardiac contact.
- The system shall not be serviced or maintained while in use with a patient.
- Install the system according the EMC guidance provided in Appendix D
- Do not stack the system on other electronic equipment.
- The use of transducer and connecting cable not supplied by EDAN may result in increased emissions or decreased immunity of the equipment.
- Refer to Appendix D for recommended separation distances from other equipment, including portable and RF communication devices.
- The mains plug is used to isolate the system from main power. Position the system so that it is easy to disconnect it from the power supply.
- No modification of this equipment is allowed.
- The system should be maintained regularly, at least annually, by a qualified technician who has adequate training, knowledge and experience. That person should be familiar with the Service Manual, available from your Edan representative.
- Keep non-medical equipment out of the vicinity of the patient. (1.5m/6ft.)
- Use of an extension cord or multi-socket outlet setup to provide power to the ultrasound system or to the system's peripheral devices, may compromise the system grounding and cause the system to exceed current leakage limits.
- It is not suggested to use a multiple socket-outlet with the device. If one is required, make sure that the multi-socket complies with the requirement specified in Chapter 16 of IEC 60601-1, or the multi-socket is with an isolation transformer. And the multi-socket shall not be placed on the floor.
- **SHOCK HAZARD** - Don't connect electrical equipment, which has not been supplied as a part of the system, to the multiple portable socket-outlet supplying the system.
- **SHOCK HAZARD** - Don't connect non-electrical equipment, which has been supplied as a part of the system, directly to the wall outlet when the non-medical equipment is intended to be supplied by a multiple portable socket-outlet with an isolation transformer.
- Edan recommends the use of isolated connectors on any electrical equipment attached to the system, and/or using isolation transformers that comply with IEC60601-1 to power that electrical equipment.
- Always use sterile technique during a biopsy procedure. Sterilize the needle guide assembly between uses.

- Use a sterile needle with each use.
- The system may be interfered with by other equipment, even if that other equipment complies with CISPR EMISSION requirements.
- The system cannot be used together with high-frequency surgical equipment.
- Remove the battery from the device when the device is not used for a long time.

#### Transducer Warnings

- To avoid infection, always use protective gloves when cleaning or disinfecting
- Read and follow all manufacturer instructions for disinfection agents.
- To avoid infection, ensure that expiration date of the disinfecting solution has not passed.
- Disinfect the transducer after each intra-cavity or intra-operative procedure. Use a new sterile sheath for each such procedure.
- Use a pyrogen-free transducer sheath for intra-operative procedures.
- The system is not intended to come into contact with the central nervous system and central cardiovascular system.
- Unplug the transducer from the system prior to cleaning or disinfecting.
- Do not immerse the transducer beyond the point indicated in Figure 6-3.
- Do not allow the transducer connector to get wet.
- "Intra-operation" exam preset must be used when doing intra-operative examination using transducer L17-7SQ.

## 2.2 Cautions

- Excessive dust and dirt could clog internal airflow and cause overheating. Do not use in a dusty environment.
- Do not use a battery that leaks, emits an odor, appears deformed, or discolored. Immediately replace it with a new Edan-supplied battery and dispose of the old battery according to local regulations. Replace a battery that has reached the end of its service life.
- Use care when storing or disposing of batteries. Do not allow the leakage from one battery to come in contact with other batteries. Batteries (including button cell on the main board) are hazardous waste. Do not dispose of them together with household garbage. At the end of their life hand the batteries over to the applicable collection points for the recycling of waste batteries. Inappropriate disposal of waste may contaminate the environment.
- Inspect the system regularly, at least weekly. Before use ensure there is no visible evidence of damage to the equipment, cables, and transducers. If a component is damaged, replace it before use.
- Do not use in locations subject to vibration.
- Do not exert excessive vibrations onto the system. Otherwise, it may damage the mechanical components (such as wheels). If the system is required to move on an uneven surface frequently, consult EDAN or authorized representatives for service.
- Read and understand the *Appendix B.2 Ultrasound Safety and the ALARA Principle* before using the system. Do not expose a patient to ultrasound energy longer than clinically reasonable.
- Practice ALARA principle when operating ultrasound system. Minimize the acoustic power

without compromising the image quality.

- Do not use in the presence of a flammable anesthetic.
- The system generates radio frequency energy, which may cause interference with other devices in the vicinity. If interference is suspected, try re-orienting or relocating the equipment.
- The use of electrosurgical units or other devices that generate radio frequency interference may cause image distortion or other malfunctions.
- The system should only be used by a qualified physician or allied health professional for ultrasound evaluations.
- Use only Edan supplied or recommended parts and accessories.
- Verify measurement results prior to entering them into a report.
- Contact your local distributor or Edan Service if there is excessive noise from the system speaker or fans.
- Please read and understand cleaning instructions prior to use.
- Please read and understand maintenance instructions prior to use.
- Please read and understand instructions for system operation prior to use.
- Studies stored on the system hard drive should be archived regularly. The system is not intended for long term storage of patient information. Confirm successful archiving before deleting a study from the hard drive.
- Ensure that the system vents are clear and unobstructed.
- Confirm patient identification information prior to storing or printing any exam information.
- If you have any question about maintenance, technical specifications, or system functionality, please contact your local distributor or Edan Service at: [support@edan.com.cn](mailto:support@edan.com.cn)
- Ultrasound images occasionally have artifacts, and should only be used as one part of an overall clinical assessment.
- To avoid electrical shock, turn off and disconnect the device from the AC power source before cleaning and disinfecting.
- No user serviceable parts are inside the system. All repairs on the system must be performed by EDAN certified service personnel.
- The device and accessories are to be disposed of according to local regulations after their useful lives. Alternatively, they can be returned to the dealer or the manufacturer for recycling or proper disposal.
- The packaging is to be disposed of according to local or hospital's regulations; otherwise, it may cause environmental contamination. Place the packaging at the location that is inaccessible to children.
- Properly dispose of used cleaning agents or disinfectants according to your hospital's regulation.
- The system does not need calibration as part of routine maintenance.
- The format of U disk should be FAT32.
- Do NOT place the device on slopes. It may suddenly slide, resulting in injury and/or equipment damage.
- Do NOT stand/sit on or bend over the device. It may move and make you lose your balance and tumble.

- To ensure safety, two persons are required to move the device across slopes.

#### Transducer Cautions

- Do not use disinfection agents beyond their expiration date.
- Do not use sterile sheaths beyond their expiration date.
- Inspect the transducer connector, cable, and head periodically. Do not use if there is evidence of excessive wear or damage.
- Do not operate the transducer to temperatures in excess of 40°C or store the transducer in temperatures in excess of 55°C.
- Do not kink or pull on the transducer cable.
- Broken or bent connector pins can cause image artifacts. Do not use a transducer with broken or bent pins.

#### Network Security Cautions

- Keep your ultrasound system safe to protect the patient information and data from being modified, damaged or disclosed caused by unauthorized disassembly.
- Always ensure the privacy of patient information and data displayed/stored in the ultrasound system or exported to external storage devices.
- The software upgrade can only be performed by EDAN-qualified service professionals with upgrade files of known provenance. Confirm that the system boots to imaging after an upgrade.
- Make sure the ultrasound system is used under secure network environment, and all the approved devices connecting with the ultrasound system are physically secure.
- Anti-virus measures such as USB device virus scanning should be carried out prior to using the USB flash drive.
- Do not connect an USB device with unknown provenance to the ultrasound system.
- When the ultrasound system is returned for maintenance, disposed of, or removed from the medical institution for other reasons, ensure all patient data are removed from the ultrasound system.

#### Federal Communications Commission (FCC) Statement:

This device complies with Part 15 of the FCC Rules. Operation is subject to the following two conditions:

- This device may not cause harmful interference, and
- This device must accept any interference received, including interference that may cause undesired operation.

This equipment has been tested and found to comply with the limits for a Class B digital device, pursuant to part 15 of the FCC Rules. These limits are designed to provide reasonable protection against harmful interference in a residential installation. This equipment generates uses and can radiate radio frequency energy and, if not installed and used in accordance with the instructions, may cause harmful interference to radio communications. However, there is no guarantee that interference will not occur in a particular installation. If this equipment does cause harmful interference to radio or television reception, which can be determined by turning the equipment off and on, the user is encouraged to try to correct the interference by one or more of the following measures:












- Reorient or relocate the receiving antenna.
- Increase the separation between the equipment and receiver.
- Connect the equipment into an outlet on a circuit different from that to which the receiver is connected.
- Consult the dealer or an experienced radio/TV technician for help.













This equipment complies with FCC radiation exposure limits set forth for an uncontrolled environment. This equipment should be installed and operated with minimum distance 20cm between the radiator & your body.








Any changes or modifications not expressly approved by the party responsible for compliance could void the user's authority to operate the equipment.

## 2.3 Labeling Symbols

The following labels are used on the system:

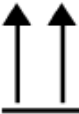






No.	Symbol	Definition
1		Serial Number
2	<i>P/N</i>	Part Number
3		Date of Manufacture
4		Manufacturer
5		Consult operating instructions
6		Warning (Background: Yellow; Symbol & outline: Black )
7		Refer to User Manual (Background: Blue; Symbol: White)
8		Caution
9		Biological Risks
10		CE Marking
11		Authorized Representative in the European Community
12		Disposal method. Indicates that the equipment should be sent to special agencies according to local regulations for separate collection after its useful life.

13		General Symbol for Recovery / Recyclable
14	<b>Rx only</b>	Caution: Federal (U.S.) law restricts this device to sale by or on the order of a physician.
15	IPX7	No harm for short time immersion
16		Type BF Applied Part
17		Transducer connector
18		Pencil Transducer connector (reserved)
19	ECG	ECG connector
21		Transducer lock
22		Transducer unlock
23		Equipotential grounding
24		Network port
25	<b>EDAN</b>	Trademark
26		Video Output port
27		USB 2.0 port
28		USB 3.0 port
29	HDMI	HDMI port
30		Microphone input

31		Audio output
32		AC power indicator
33		Batter charging indicator
34		Up/Down button, to move the control panel up or down
35		Non-ionizing electromagnetic radiation.
36	<b>FCC ID:SMQLX9EDAN</b>	Federal Communications Commission: FCC ID:SMQLX9EDAN
37		Type CF Applied Part with Defibrillation-proof protection
38		Non-sterile. Indicates a medical that has not been subjected to a sterilization process.
39	IP68	Dust-tight (No ingress of dust); No harm for continuous immersion in water



The following labels are used on the wooden packaging:

No.	Symbol	Definition
1		This way up
2		Fragile, handle with care
3		Keep dry
4		Stacking limit by number
5		Do Not Roll.
6		General Symbol for Recovery / Recyclable
7		Tilt monitored equipment.

**NOTE:**

The user manual is printed in black and white.

## 3 Getting Started

### 3.1 System Configuration

#### Standard Configuration:

- ◆ 1 main unit
- ◆ 1 power cord
- ◆ 1 potential equalization conductor
- ◆ 1 bottle of coupling gel
- ◆ 1 basic user manual and 1 advanced user manual

#### Options:

- ◆ Transducers: L17-7HQ, E8-4Q, C5-2Q, L12-5Q, L17-7SQ, MC8-4Q, P5-1Q, P7-3Q, MC9-3TQ, C7-2XQ, E10-3BQ, E10-3HQ, C6-2MQ, C5-1Q
- ◆ Needle Guide Bracket Kit

<i>Model</i>	<i>Angle/Depth</i>	<i>Description</i>
BGK-C5-2	20°, 28°, 40°	For use with the C7-2XQ/C5-2Q, Supports: 14G-23G
BGK-L40UB	34°, 43°, 53°, 66°	For use with the L17-7HQ, Supports: 14G-23G
BGK-CR10UA	2°	For use with the E8-4Q, Supports: 16G, 18G
BGK-R15UB	12°, 20°, 35°	For use with the MC8-4Q, Supports: 14G-23G
BGK-001	1.0cm, 1.5cm, 2.0cm	For use with the L17-7HQ, Supports: 21G
BGK-004	12°, 20°	For use with the MC9-3TQ, Supports: 14G-23G
BGK-005	0°	For use with the E10-3BQ, Supports: 16G, 18G
BGK-006	1°	For use with the E10-3HQ, Supports: 16G, 18G
BGK-007	18°, 25°, 35°	For use with the C5-1Q, Supports: 14G-23G

Table 3-1 Needle Guide Bracket Kits

- ◆ Footswitch
- ◆ Ultrasound gel warmer
- ◆ USB disk

- ◆ Two batteries
- ◆ Wifi module
- ◆ ECG module

**Supported Peripheral Accessories:**

- ◆ The recommended printers are listed as follows:

<b>Printer Type</b>	<b>Printer Model</b>	<b>Interface</b>
Color Video Printer	SONY UP-25MD	S-Video
	SONY UP-D25MD	USB
B/W Video Printer	SONY UP-X898MD	USB
Report Printer	HP Officejet Pro 251dw	USB
	HP LaserJet Pro 200 color M251n	USB
	HP LaserJet CP1525n Color	USB
	HP Deskjet Ink Advantage 2010	USB
	HP Deskjet 1010	USB
	HP Deskjet 1510	USB
	HP LaserJet 400 M401d	USB
	HP DeskJet Ink Advantage Ultra 2029	USB
	HP DeskJet 1112	USB
	Canon E518	USB
	Canon iP2780	USB
	HP LaserJet Pro MFP M126nw	USB
	HP DeskJet 1050	USB
	HP DeskJet 2050	USB
HP LaserJet M252n	USB	

Table 3-2 Printer List

Many other printers may also work with Acclarix systems. To check if your printer works, connect it to the system, go to **Set-up->Store/Print**, and click the **Add** button. Once it is added, confirm correct operation by clicking the **Test** button.

If that does not work, you may need to download a printer ppd file from the printer supplier. In that case download the ppd file to your local computer, and then copy it to a USB stick inside a directory named "ppd". Insert that USB stick into the Acclarix system along with the printer and try again. Most, but not all, printers will work with the Acclarix systems. A list of printers that should be compatible can be found at [https://developers.hp.com/hp-linux-imaging-and-printing/supported\\_devices/index](https://developers.hp.com/hp-linux-imaging-and-printing/supported_devices/index), or at [http://gimp-print.sourceforge.net/p\\_Supported\\_Printers.php](http://gimp-print.sourceforge.net/p_Supported_Printers.php).

**WARNING**

Only the recommended printers listed above are verified by EDAN. Therefore, it is suggested to only use these printers. Use of other printers should comply with IEC 60950 or IEC 60601-1. Edan is not responsible for the accuracy of other printers.

- ◆ Recommended DVD drives: LITEON

## 3.2 System Overview

### 3.2.1. Main Unit

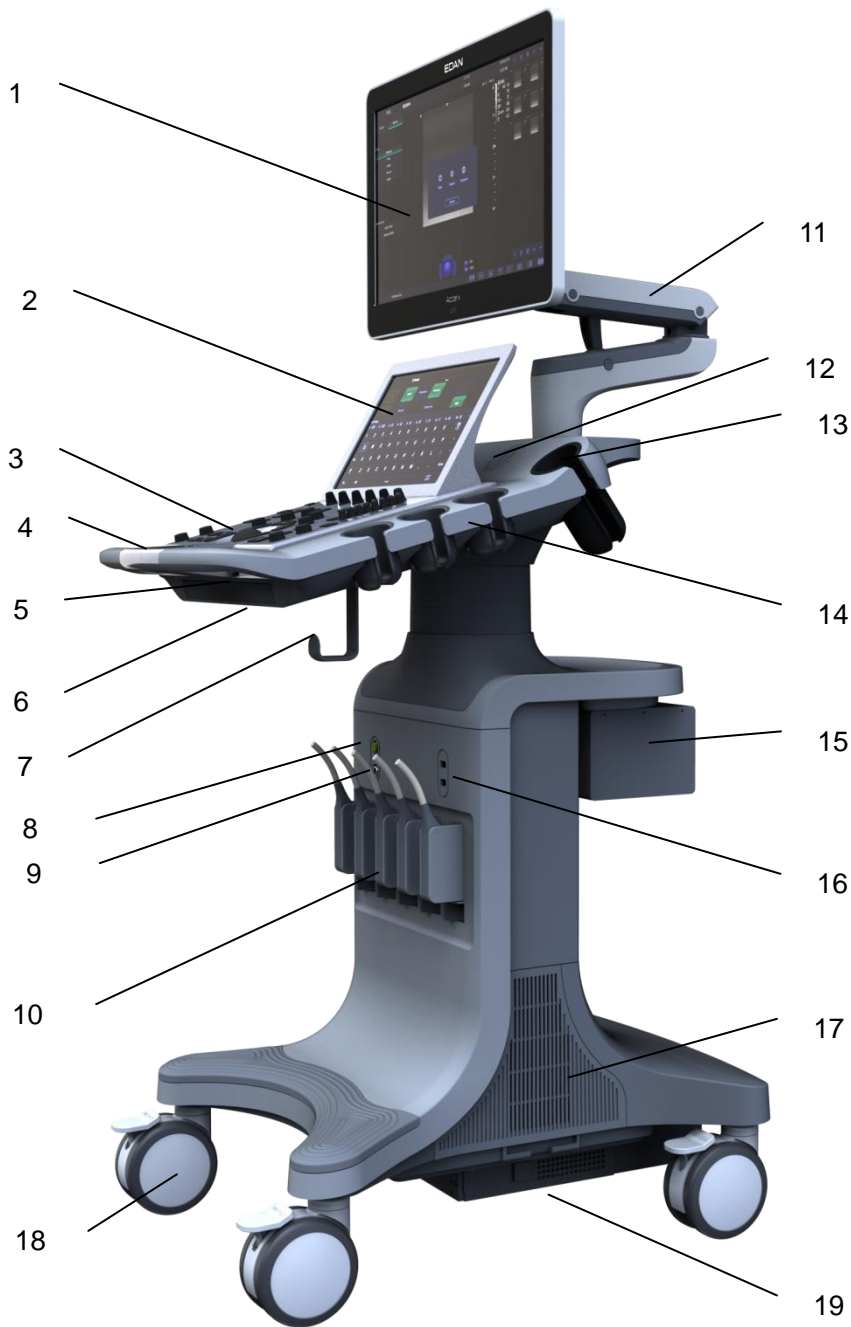


Figure 3-1 Main Unit

<b>No.</b>	<b>Description</b>	<b>No.</b>	<b>Description</b>
1	Monitor	11	Monitor Support Arm
2	Touch Screen	12	Speaker
3	Control Panel	13	Coupling Gel Holder
4	Handle	14	Transducer Holders
5	Control Panel Height Adjusting Lever	15	Video Printer /DVD Drive(optional)
6	Physical Keyboard	16	USB Port(two)
7	Cable Holder	17	System Vents
8	ECG Connector	18	Wheels(four)
9	Pencil Transducer Connector (Reserved)	19	Battery Compartment
10	Transducer Sockets(five)		

Table 3-3 Main Unit Description

Press down the keyboard case on figure 3-1 to open the keyboard for editing. Push it back after usage.



Figure 3-2 System Keyboard

**CAUTION**

1. Ensure system vents are clear and unobstructed.

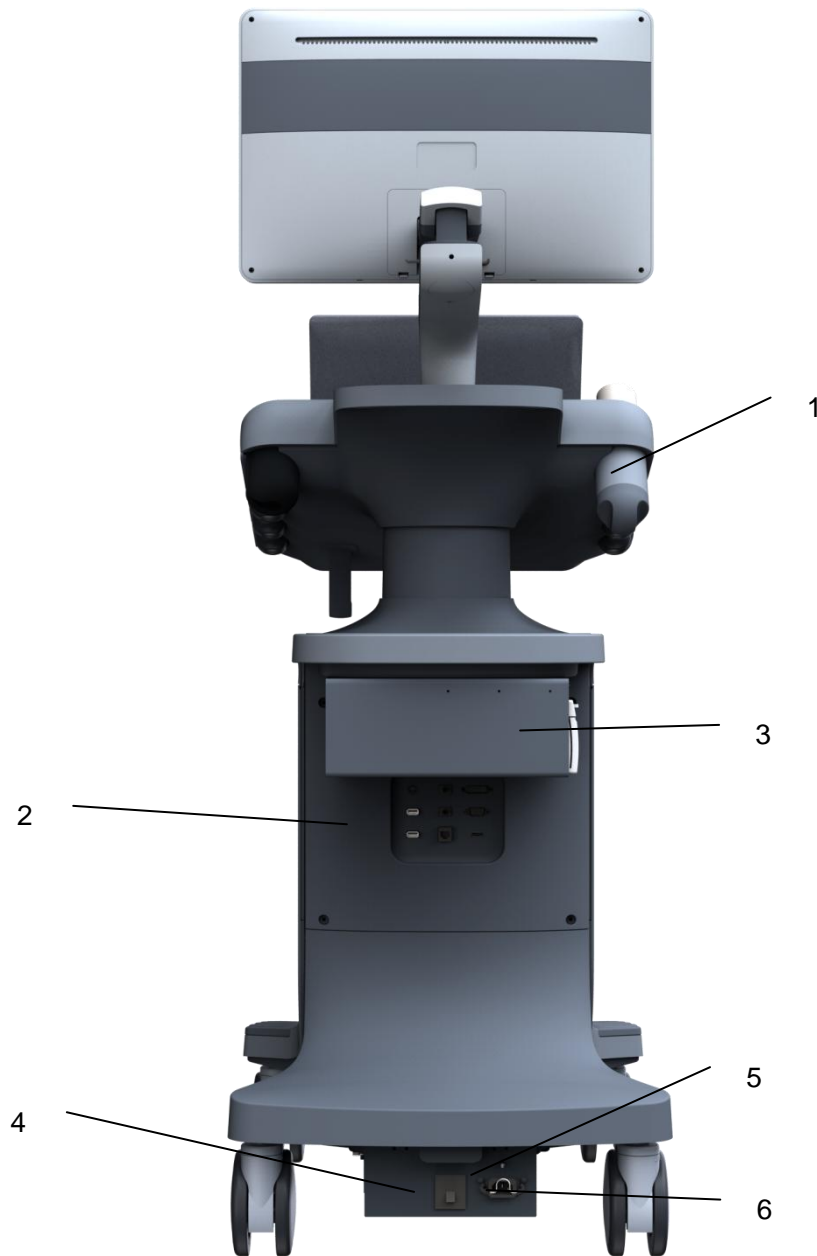


Figure 3-3 Rear View

<b>No.</b>	<b>Description</b>	<b>No.</b>	<b>Description</b>
1	Coupling Gel Holder/ Gel Warmer(Optional)	2	I/O Ports
3	Video Printer/DVD Drive(Optional)	4	Air Switch
5	Equipotential Terminal	6	AC Power Socket

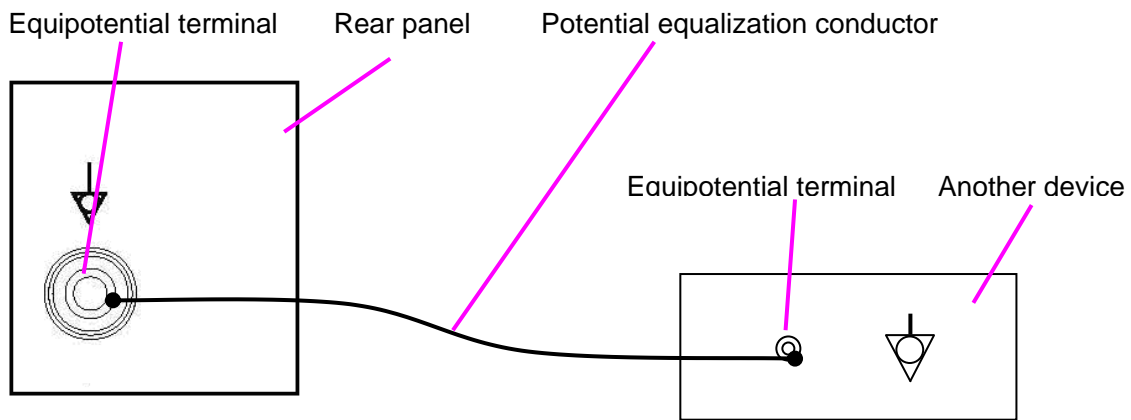
Table 3-4 Rear View Description

**CAUTION**

1. To facilitate the disconnection from power supply, please do not cover the AC power socket with any object.

**Equipotential Connection**

The equipotential terminal is used for balancing the protective earth potentials between the ultrasound system and other electrical devices. Perform the equipotential connection as the following illustration.



**WARNING**

1. When you connect another device to the ultrasound system, a potential equalization conductor should be used to connect each of the equipotential terminals. Otherwise, electric shock may result.
2. Any device connected to the ultrasound system must meet the requirements of the applicable IEC/EN60601 series safety standards, and/or the system configuration must meet the requirements of the IEC/EN60601-1.

**I/O Ports on the Rear Panel**

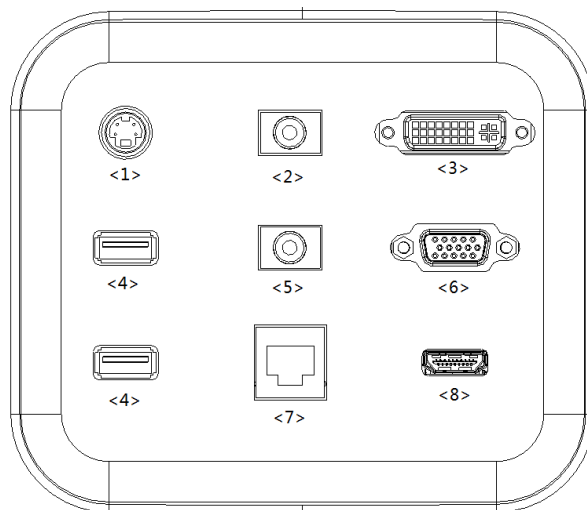


Figure 3-5 I/O ports

No.	Description	No.	Description
1	S-Video output port	2	Audio output port
3	DVI port	4	USB port
5	Microphone port	6	VGA port
7	Network Port	8	HDMI port

Table 3-5 I/O ports description

**Caution**

1. The resolution of the external display which connects to DVI port or HDMI port should be 1080P, otherwise the display will be abnormal.

**3.2.2. Control Panel**

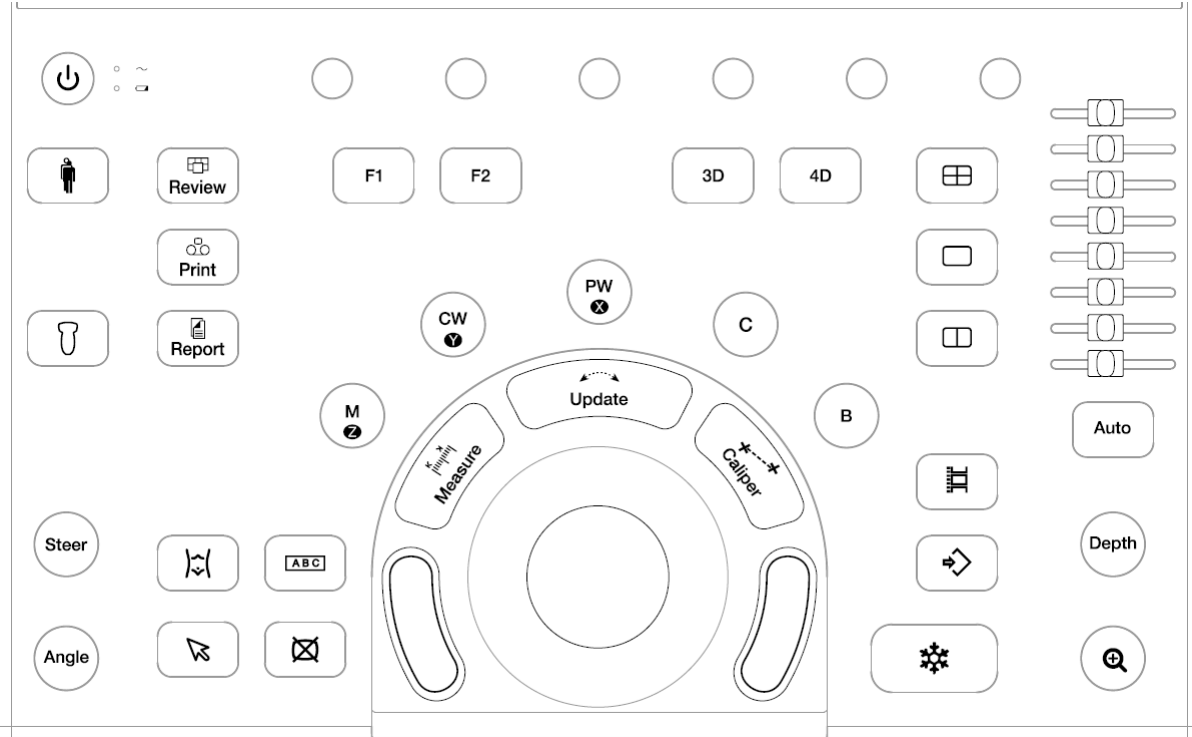








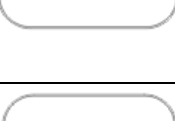
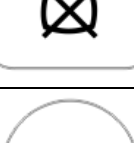
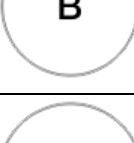





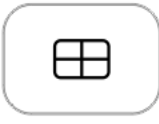
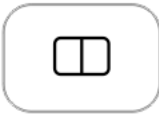
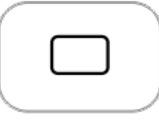




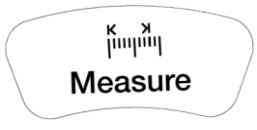
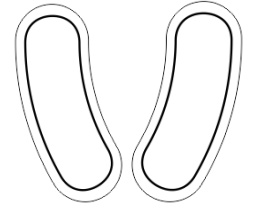


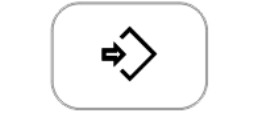

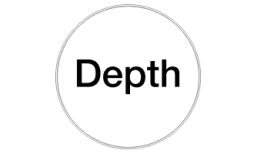

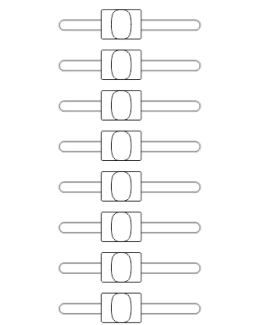
Figure 3-6 Control Panel

No.	Key	Name	Description
1.		Power Switch	Press to power on/off the system. ~ : AC power supply indicator. It illuminates in green when the system is connected to AC power supply. : Battery charging indicator. It illuminates in green when the battery is charging.
2.		Patient	Invokes the Patient Information Screen typically used to start/end exams or to modify patient information during an exam.
3.		Transducer	Press to switch transducer or exam presets.
4.		Review	Press to enter exam database or image review mode. See section 9.2 for details.
5.		Print	Press to print images via the connected USB video printer.



6.		Report	Press to display the report page.
7.		F1	User-defined button. See section 11.1.1 for configuring the user-defined button.
8.		F2	
9.		Steer	The Steer knob control is only available for linear transducers. It can steer B-mode image, Color ROI, PW sample line, etc. Specific operations thereof are described throughout the user manual.
10.		Angle	Adjusts the angle of comment, body marks, needle, M sample line, etc. Specific operations thereof are described throughout the user manual.
11.		Body Mark	Enters or exits the Body Mark function.
12.		Comment	Enters or exits the Comment function.
13.		Cursor	Press to hide or display the mouse cursor. When pressing Cursor while using the Comments function, the system will display a green cursor in the image field that can be used to point to anatomical structures.
14.		Clear	Press to clear all the measurements, calculations, comments, and body marks displayed on the current image.
15.		B	Press to return to B-mode imaging from any other imaging mode and rotate to adjust the gain in B Mode.
16.		Color	Press to enter or exit Color Mode and rotate to adjust the gain in Color Mode.

17.		PW	<p>Press to get the sample line. Use the trackball to adjust the position of the sample line. Press it again or press <b>&lt;Update&gt;</b> key to display the Doppler strip. Rotate this knob to adjust the gain in PW Mode.</p> <p>In 3D/4D mode, rotating it can rotate the image by the X-axis of the activated window.</p>
18.		CW	<p>Press to get the sample line. Use the trackball to adjust the position of the sample line. Press it again or press <b>&lt;Update&gt;</b> key to display the Doppler strip.</p> <p>This knob is only available when the current active transducer is a phased transducer .</p> <p>In 3D/4D mode, rotating it can rotate the image by the Y-axis of the activated window.</p>
19.		M	<p>Press to enter or exit M Mode and rotate to adjust the gain in M Mode. Use the trackball to adjust the M sample line.</p> <p>In 3D/4D mode, rotating it can rotate the image by the Z-axis of the activated window.</p>
20.		3D	<p>Press to enter or exit 3D Mode. It is only available when the current active transducer is a wobble transducer.</p>
21.		4D	<p>Press to enter or exit 4D Mode. It is only available when the current active transducer is a wobble transducer.</p>
22.		Quad	<p>Enters quad split screen. Each single press on it toggles between four image windows.</p>
23.		Dual	<p>Enters dual split screen. Each single press on it toggles between two image windows.</p>
24.		Single	<p>Press to display the currently active side of Dual image as a single image.</p>
25.		Update	<p>In measurement, pressing <b>&lt;Update&gt;</b> switches the active side of calipers. See section 8.1 for details.</p> <p>In Pre-Doppler mode, pressing <b>&lt;Update&gt;</b> invokes Spectral Doppler mode. When Spectral Doppler strip is displayed, pressing Update allows switching between live acquisition of the Doppler strip or the reference image.</p>

26.		Caliper	Invokes generic measurements. See section 8.1 for details.
27.		Measure	Invokes application measurements. See section 8.2 for details.
28.		Trackball Keys	Two trackball keys provide a wide variety of functions depending on the system state (e.g., selects a start or end point of a measurement, selects menu items on the screen, etc). For the convenience of introduction, we call them <Set> throughout this user manual.
29.		Trackball	Move the trackball to change the cursor position, adjust M mark position in M mode, adjust sample line position in PW mode, etc.
30.		Store Clip	Press to store clips.
31.		Store Image	Press to store static images.
32.		Freeze	Press to switch between the frozen and real-time states.
33.		Depth	Rotate to adjust the depth of the image displayed. Rotate counterclockwise to decrease the depth and rotate clockwise to increase.
34.		Zoom	Rotate to use Pan Zoom function, and press to use Spot Zoom function. See section 7.4 for details.
35.		TGC	<p>The Time Gain Compensation control (TGC) adjusts the gain of the image at different depths. Each slider can be adjusted separately.</p> <p>Glide the slide controls to adjust the TGC. Glide the upper segments to adjust the near field gain, and the lower segments to adjust the far field gain; glide rightward to increase TGC, and glide leftward to decrease.</p>



36.		Auto	<p>In B mode, the Auto push button automatically updates the Overall Gain and TGC.</p> <p>In PW mode, the Auto push button automatically updates the PW gain, DR, baseline and scale.</p> <p>In Color mode, this Auto push button automatically updates the gain and scale.</p> <p>Each single press of the button renews the automatic optimization. Whether Gain, DR or Scale/Baseline is optimized when pressing Auto button in PW mode can be configured in Set-up. See section 11.1.4 for detail.</p>
37.		Touch screen paddle Knob(Six)	Each of these six knobs adjusts the setting value of one corresponding paddle control above it on the touch screen.

Table 3-6 Buttons on Control Panel

### 3.2.3. Screen Layout

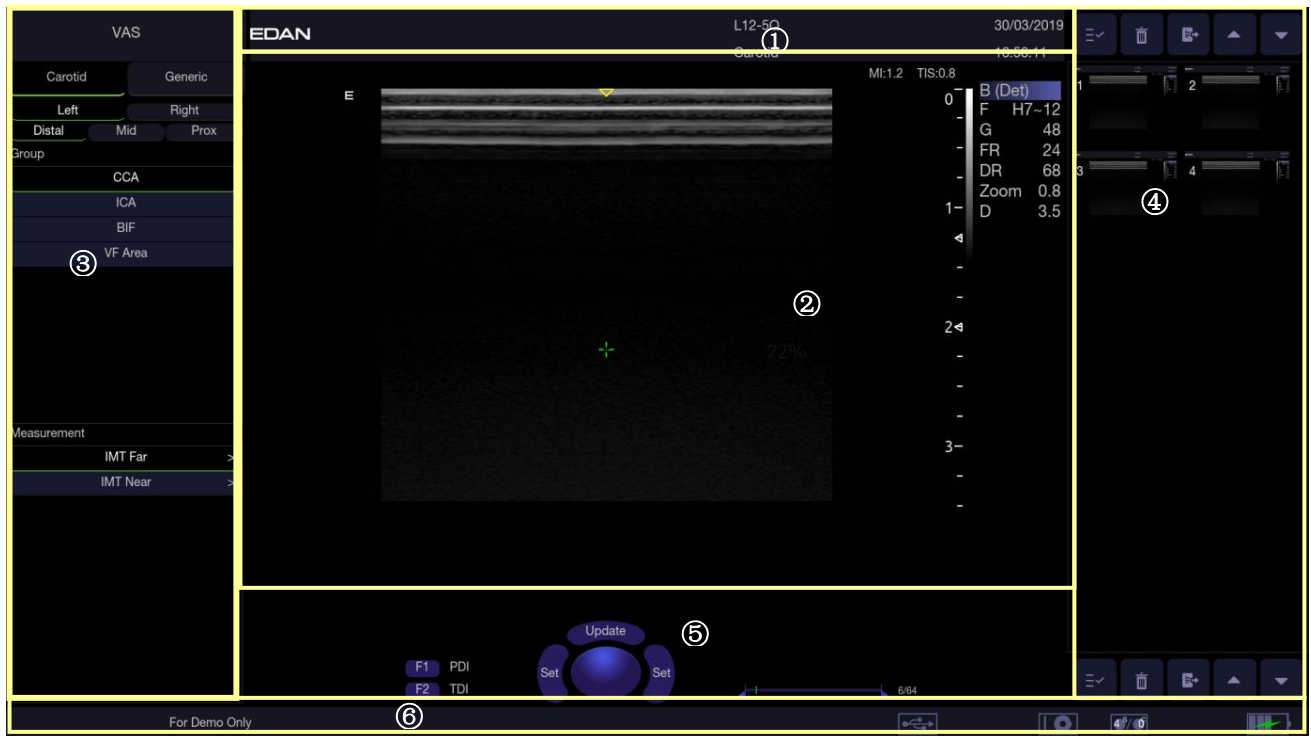


Figure 3-7 Main Screen Display

#### ① Information Field

The top line of this field contains your hospital/institution name. Please see Section 11.1.1 *General Set-up* for information on customization.

The second line of this field contains the patient name, gender, age and ID, as entered through the Patient Information screen.

This field also contains data fields for:

- The currently active transducer
- The currently active preset
- System date and time.

② **Image Field**






The ultrasound image appears in the Image field, under the Information field. The Image field also contains information typically associated with the image, such as depth, TGC, maps, image parameters, MI and TI.

③ **Measurements Display Field**

The left side of the screen displays available generic and application measurement items for current exam preset.

④ **Thumbnail Field**

The right side of the screen displays thumbnail images of all statics and clips captured for currently active exam or when in Review. This field also contains several shortcut keys for selecting, viewing, deleting, exporting images. See the below for details:

No.	Shortcut Keys	Description
1	 Select All	Selects all the displayed static images and clips.
2	 Delete	Deletes the selected static images and clips.
3	 Export	Exports the selected static images and clips to removable storage devices.
4		Previous/Next Images Views previous or next images when more than one page of images are displayed.
		


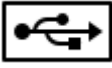

⑤ **User Feedback Field**











The user feedback field is displayed below image field and above status bar. This field displays:







- The illustration of trackball and trackball keys.
- Cine bar when the system is frozen.
- The active function of user custom key F1 and F2.

⑥ **Status Bar**

The bottom of the screen is used to display icons that provide system status. These include:

No.	Icons	Description
1	Image Store icon 	Displays the number of static images and clips stored in the current exam.
2	USB icon 	USB available.
3	Printer icon 	Printer available.

4	Wi-Fi icon		<p>Wi-Fi function is enabled, but no WI-FI network is connected.</p> <p>No WI-FI icon will be displayed when Wi-Fi function is disabled in <b>Connectivity</b> setup.</p>
			<p>Wi-Fi network is connected.</p> <p>Clicking on this icon shows a list of available Wi-Fi networks. Selecting an available network displays a dialog box for entering password. Clicking on the "WiFi: Turn off" button above the list will disconnect the currently connected WI-FI network.</p>
			<p>Wi-Fi network is disconnected.</p> <p>Clicking on this icon shows a "WiFi: Turn on" button. Clicking on this button shows a list of available Wi-Fi networks. Selecting an available network displays a dialog box for entering password.</p>
5	Network status icon		<p>The network status icon shows the connection status of the Network Server. If no Network Server is defined, then the icon is not displayed.</p> <ul style="list-style-type: none"> <li>• Outline in grey color: Successful connection with a Server.</li> <li>• Outline in green color: Data exchange with a Server.</li> <li>• Outline in red color: Failure to connect with a configured Server</li> </ul> <p>Clicking on this icon displays a queue of exam or image transfers and as well as the transfer status of each exam or image including refuse, pending, active, success and fail. For a failed transfer, the system will automatically retry the transfer when the transfer task is available, or user can manually retry transfer. User can manually delete a transfer from the queue.</p>
6	Hard Drive icon		Hard drive available.
			Hard drive data exchange, symbol in green.
			Hard drive 95% full, symbol in red.
			Hard drive 95% full with data exchange, symbol in red.
7	Battery icon		Battery fully charged, symbol in green.
			Battery more than 80% charged.

			Battery 60%-80% charged.
			Battery 40%-60% charged.
			Battery low, symbol in red.
			Battery removed, outline in red.
			Battery charging.
8	DVD icon		Symbol in grey: DVD device is connected. Symbol in green: DVD device is connected, disc is inserted and data transmission is available.

### 3.2.1. Touch Screen

The Touch Screen contains controls that vary depending on the active imaging mode or function. There are several types of controls used by the touch screen, as illustrated below:

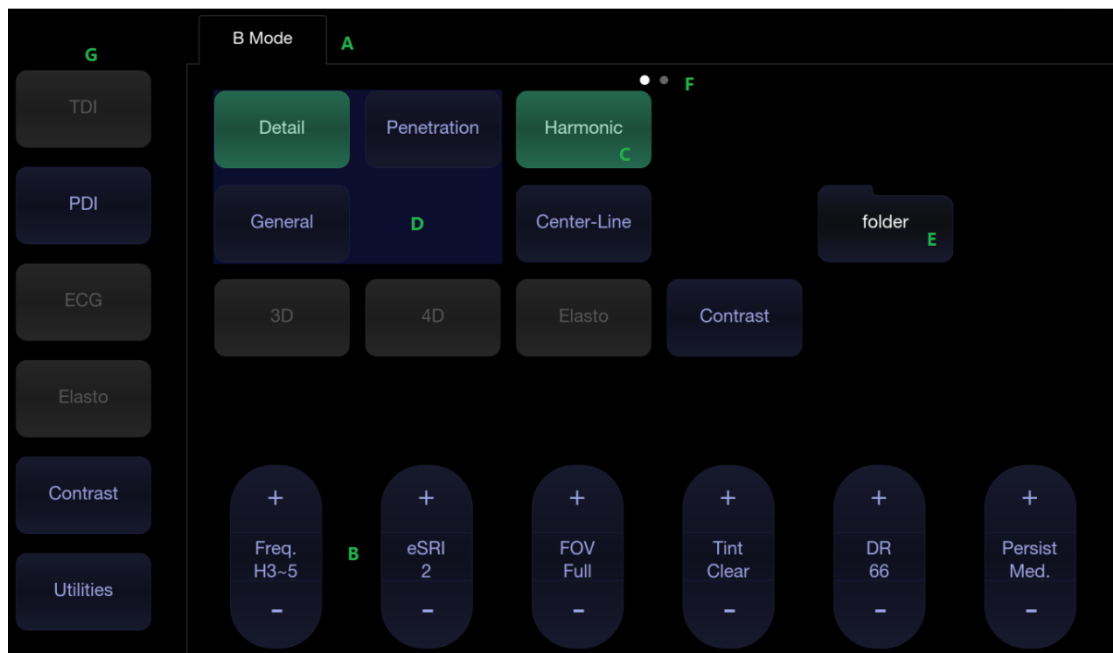
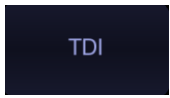
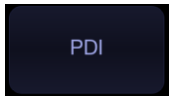
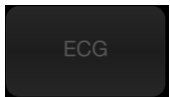
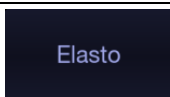
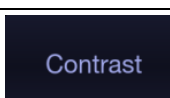
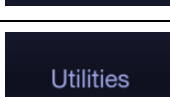


Figure 3-8 Touch screen of the System

- A. Tabs: Each imaging mode that is active has a tab at the top of the touch screen. Usually, the imaging mode that was most recently activated is the top tab and has priority. Pressing on any other tab will bring it to the top and provide access to the controls available for that imaging mode.
- B. Paddle: Pressing on the top or bottom of a paddle changes the control setting by one value. Pressing anywhere on the control and swiping across it will continuously change the value. Each touch screen page displays at most six paddles. Below each paddle there is a knob on the console used to change its setting. Pressing and dragging one paddle to the position of another paddle will switch the position of these two paddles.
- C. Push Button: This can either be an on/off control (like “Colorize”) or a one-shot control that

immediately performs an action (like “Auto”)

- D. Radio Buttons: A collection of buttons where only one is active at any time. Activating one will de-activate all others.
- E. Folder: Controls can be grouped together into a folder. Press on the folder to open it and access any of the controls within it.
- F. Pages: When a tab has multiple pages of controls each page is represented by a dot at the top of the page. The current page is indicated by a filled-in dot. You can move between pages by dragging your finger horizontally across the dots. These dots do not appear when there is only one page in the current tab.
- G. Function Shortcut Key: The left side of the touch screen displays six shortcut keys for accessing different imaging modes or functions. See the following table for details:

<b>No</b>	<b>Name</b>	<b>Description</b>
1		Press to enter Color-TDI mode.
2		Press to enter TDI mode.
3		Press to activate ECG function.
4		Press to enter Elastography mode.
5		Press to enter Contrast Imaging mode.
6		Press to open <b>Utilities</b> touch screen, where system setup, connectivity, presets, screen adjust, system maintenance can be accessed.

The function of shortcut key 1 to 5 can be configured on System Setup page. See section 11.1.1 for details.

### **Customizing the touch screen**

The touch screen can be customized to meet your needs. Press and hold any control for about a second to put the touch screen in customization mode. Continue pressing and drag the control to a new location.

- Creating Folders: Dragging one control on top of another control will create a folder that contains both controls. Dragging controls out of a folder until only one exists will automatically delete that folder. Folders cannot contain other folders.
- Multiple pages: Dragging a control to the side of the screen will move that control to the next page.
- Radio Button Cluster: There is no restriction on moving a single radio button. However, we suggest that they are grouped adjacent to each other. When they are grouped in this way the system will automatically draw a border around them to indicate they are a related group of radio buttons.



### **3.2.4. Trackball**

The trackball operation is easy and convenient. It can achieve the following functions:

- ◆ Move the measurement cursor during measurement.
- ◆ Move the comment cursor in the comment status.
- ◆ Move the M Mark in the B+M mode.
- ◆ Move the scan area of Color mode, increase or decrease the size of scan area of Color mode.
- ◆ Move the sample line in the PW/CW mode.
- ◆ Realize single frame playback in the frame-by-frame playback status.
- ◆ Move the zoomed window in the zoom status.

**NOTE:**

1. Please be gentle when running the trackball.
2. Please keep the surface of trackball clean.

## 3.3 System Preparation

### 3.3.1. Battery Use

The system may come with two lithium-ion batteries depending on your order. The fully charged batteries together can run the system for approximately 1.5 hours, depending on use. The batteries are automatically charged when the system is plugged in.

#### **CAUTION**

1. If the system will remain unused for more than one week, charge the battery to at least 75% capacity, take the battery out and store the system and battery separately.
2. During long term storage, the battery should be charged at least once every 6 months to ensure battery capacity is more than 75%.
3. Only use Edan supplied battery.
4. Two batteries should be used together to power the system on.

To install the battery:

1. Find the battery compartment, located at the lower right side of the system(see figure 3-1) .
2. Unscrew the two screws on the battery door, and open the battery compartment.



3. Move the battery holder (see the figure below) up or down, and put two batteries inside respectively. The side with labeling should face down when putting the battery in.





4. To fix the battery, move the battery holder to the middle position (see the figure below).



5. Close the battery door and secure it.

---

**WARNING**

1. When the battery capacity is  $\leq 20\%$ , the battery status icon turns red.
2. When the battery capacity is  $\leq 10\%$ , the system displays a prompt "Low Battery. Please plug in the adapter to ensure uninterrupted use."

---

To remove the battery:

1. Find the battery compartment, located at the lower right side of the system(see figure 3-1) .
2. Unscrew the two screws on the battery door, and open the battery compartment.



3. Move the battery holder (see the figure below) up or down, and remove two batteries respectively.



4. Close the battery door and secure it.

### **3.3.2. AC Power Use**

When using AC power, position the system so that it is easy to disconnect it from AC power supply.

To connect AC power:

1. Connect the AC power cord to the power socket on the system(see figure 3-3).
2. Connect the AC power cord to a hospital-grade power outlet.
3. Toggle the Air Switch beside the power socket to "ON" position.
4. Press the Power button on the control panel to start the system.

---

#### **WARNING**

1. Make sure the AC power supply complies with the following specifications: 100V-240V~, 50Hz/60Hz.
  2. Only use a hospital grade, grounded, power outlet and plug. Do not use with an ungrounded outlet.
  3. Only use Edan supplied power cord.
- 

### **3.3.3. Transducer Connection**

**To connect a transducer:**

1. Align the connector with the transducer port and carefully push into place.
2. Toggle the locking handle to the right position.
3. Do not allow the transducer head to hang free. Impact to the transducer head could result in irreparable damage.

**To disconnect a transducer:**

1. Toggle the locking handle to the left position to unlock the transducer connector.
2. Firmly grasp the transducer connector and carefully remove it from the system port.
3. Store transducer in its protective carrying case prior to transport.

---

#### **CAUTION**

1. Do not touch the pin of transducer connector.
  2. Broken or bent pin will affect the image quality. Please do not the transducer with broken or bent pin.
  3. Do not plug in or pull out the connector when the device is activated. This is to avoid uncontrollable damage to the transducer and the main unit.
-

4. Ensure the transducer is connected firmly and properly. This is to avoid bad contact between the transducer and transducer socket.
5. Ensure that the system is shut down, or the image is frozen, before connecting and disconnecting transducers.

### 3.3.4. Powering on/ off

Please review and follow the steps described in the Section *13.1.Daily Checklist* prior to powering on the system.

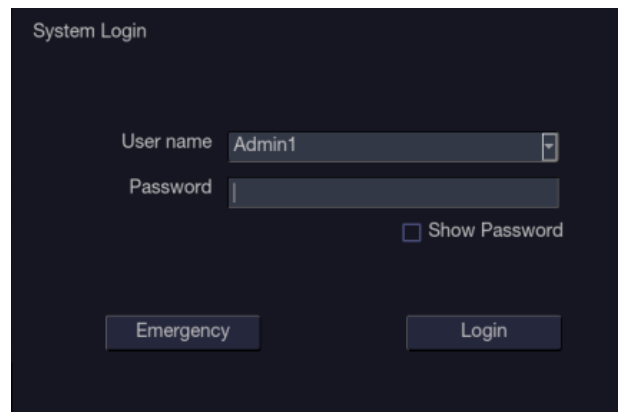
#### To power on

1. Connect the AC power supply.  
Or, use the battery as the power supply.
2. Press the Power on/off key on the top left of control panel.

#### To Login

If Password Protection is enabled (see section 11.1.5), the system displays a Login dialog when booting up the system. Type in or select user name from the User Name drop-down list, then enter password and click **Login**.

For emergency use, click on **Emergency** to log on directly without entering user name and password.



The screenshot shows a dark-themed 'System Login' dialog box. At the top left, the text 'System Login' is displayed. Below it, there are two input fields: 'User name' with a dropdown menu showing 'Admin1' and a small arrow icon, and 'Password' with a text input field. To the right of the password field is a checkbox labeled 'Show Password'. At the bottom of the dialog, there are two buttons: 'Emergency' on the left and 'Login' on the right.

#### NOTE:

1. When both Admin1 and Admin2 password are forgotten, please contact the serviceman for the system password reset.
2. It is not suggested to use Emergency login under non-Emergency situation. Please login the system with your account or switch to your account through the Switch User function (See "To Switch Users" below) prior to imaging scanning.
3. Ensure the privacy of patient information and data created through Emergency login. It is suggested to remove the patient exam data from the ultrasound system after Emergency scanning for protecting patient data from being accessed by unauthorized users.

#### To Switch Users

If Password Protection is enabled, switching users is allowed without restarting the system.

1. Press Power on/off key, and the system will display a confirmation dialog box.

2. Select **User** from the confirmation dialog box. A login information dialog box will be displayed providing access to change user.
3. Select **Change User** and this brings up the system login dialog box.
4. Select another user from the User Name drop-down list and then enter password to login.

### **To power off**

1. Press the Power on/off key on the top left of control panel and the system displays a confirmation dialog box.
2. Select "Shut Down" from the confirmation dialog box.

If the system is unresponsive, a long press of the Power on/off key will shut down the system directly.

### **NOTE:**

1. Turn off and unplug the device after use.
2. Please unplug the power cable from the power socket and disconnect the battery prior to storage.

### **Sleep mode**

The system will enter a sleep mode that maintains exam information while using minimal power. There are two events that can invoke sleep mode:

- No user input for a configurable amount of time. Please see System Set-up to configure this time.
- Pressing the **Sleep** button on the confirmation dialog box when powering off.

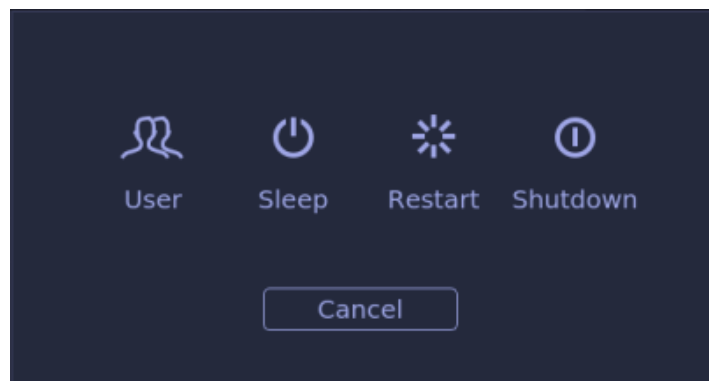


Figure 3-9 Confirmation dialog box when power off (Password protection is enabled)

Pressing any key on the control panel or moving the trackball will exit the sleep mode.

## **3.4 Monitor Position Adjustment**

Before adjusting the position of the monitor, you need to unlock the upper support arm. To unlock the upper support arm, press the release button (see the figure below).

## 4 Exam Operation

### 4.1 How to Start an Exam

1. Press the **<Patient>** key and enter in patient information, or select a scheduled patient from the modality worklist.

If there is no previous exam, pressing the **<Patient>** key will bring you directly to the Patient Information Page (see figure 4-2 below).

If a previous exam is still active you will see the following dialog:

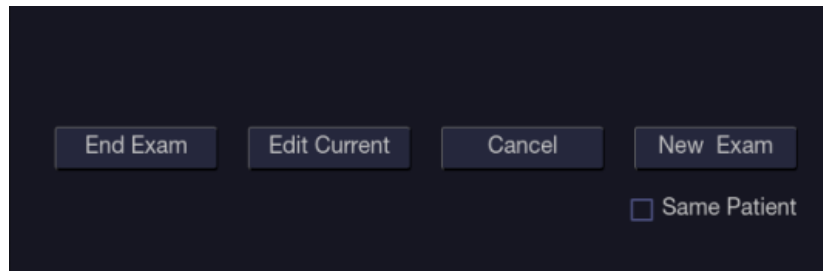


Figure 4-1 Exam Information Page

The following options are available:

- **End Exam:** select this to end the current exam and return to live imaging to start a new exam.
- **Edit Current:** This lets you edit the Patient Information for the current exam. It does not start a new exam.
- **New Exam:** Select this to start a new exam.

If **Same Patient** is checked, selecting **New Exam** will end the previous exam and create a new exam for the same patient. The main screen will display the Patient Information Page with the previously entered patient information except for the exam accession number. . Changing the patient information for one exam will not impact the others.

If **Same Patient** is unchecked, selecting **New Exam**, a blank Patient Information Page will be displayed for entering patient information for a new patient.

Tick the check box of **Same Patient** when operating multiple exams for the same patient.

- **Cancel:** Exits the dialog without starting or ending an exam.
2. Press **Start Exam** key to start scanning.
  3. To change transducer or exam preset, press the **<Transducer>** key, and then the **Transducer** touch screen provides you choices of available transducers and exam presets, as the figure below.

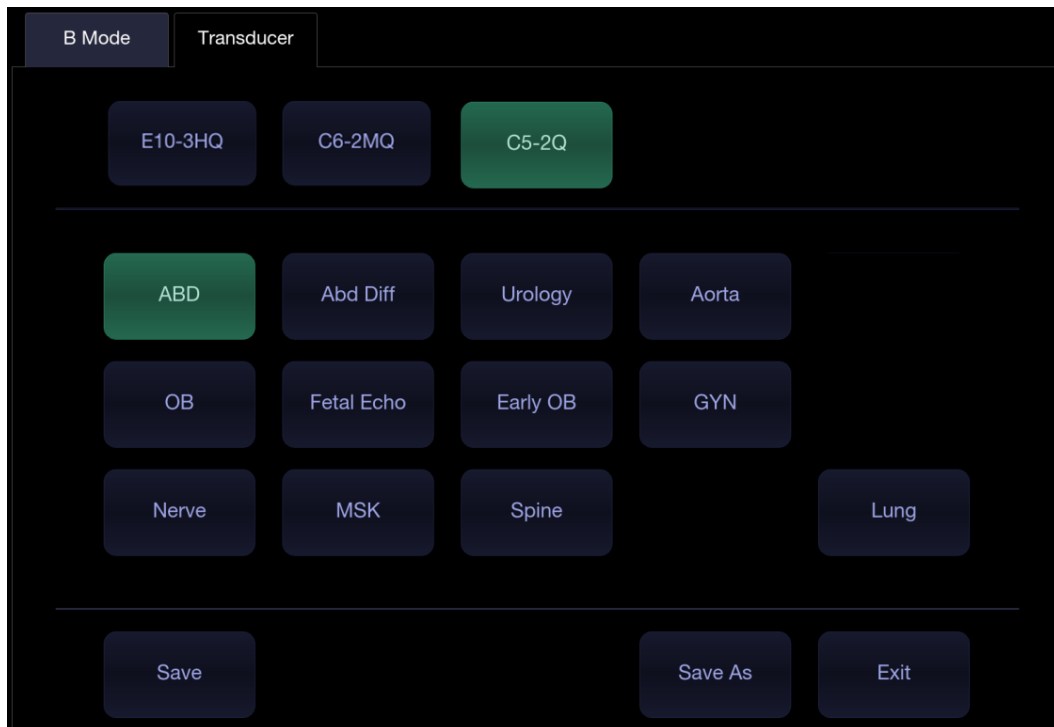


Figure 4-2 Example of Transducer Touch Screen

## 4.2 How to End an Exam

There are two ways to end an exam:

- Pressing the **<Patient>** key, as described above, and then selecting the **New Exam**. This both ends the exam and displays the Patient Information Page for the next exam.
- Pressing the **<Patient>** key, as described above, and then selecting the **End Exam**. This brings up a dialog to confirm you want to end the exam, but does not invoke the Patient Information Page for the next exam.

When an exam is ended, the associated files on the system are closed. If a DICOM server is connected successfully and **Auto-transfer when End Exam** is configured, any remaining images are transferred.

## 4.3 How to Restart an Exam

1. Select an exam from the Exam Database within the time limit selected in **Patient Set-up** menu. For the setting of time limit, refer to section *9.1.2 Patient Set-up*.
2. Press **Restart** key to continue/edit the exam that was performed on the selected patient. You can also modify the patient information by pressing **<Patient>-->Edit Current**.

## 4.4 The Patient Information Page

The Patient Information Page is used to enter or modify patient demographic data. The following figure is an example:



08/03/2019 22:34:11

Last Name  First Name

ID  Accession

DOB 01/01/2000  dd/mm/yyyy Age  Year

Transducer C5-2Q  Exam Preset OB

Gender F

LMP 08/03/2019  GA  EDD 08/03/2019

G/P/A  /  /  Fetus 1

Study Description

Ref.Physician

Dx.Physician

Operator

Comments

Start Exam Cancel Clear All Prior Exam

Figure 4-2 Patient Information Page

The top three lines are for entering the patient last name, first name, ID, exam accession number, and DOB (Date-of-Birth) or age. If date of birth is entered, the age is automatically calculated.

Note:

By default, the patient name has two fields: family name and given name. It can be configured to be one field in the Patient Setup screen (See section 11.1.2 for detail).

The next line shows the current transducer and the preset that will be used for the current exam. The preset can be changed by clicking the drop-down menu and selecting another preset associated with the current transducer.

The lines below the preset selection vary depending on the current preset and display fields that are preset-specific. All the possible patient information fields you may need to fill in are listed below:

- Gender: Select the patient's gender: "M" (Male), "F" (Female), "O" (Other), or "<blank>". "F" is default for gynecology, obstetric and breast exams; "M" is default for prostate exam and testis exam; <blank> is default for all other exam types.
- LMP: Last Menstrual Period (yyyy/mm/dd or mm/dd/yyyy), If LMP is entered then GA and EDD are calculated. Entering EDD does not impact LMP. An LMP more than 300 days ago is considered invalid.
- GA: Gestational Age (xxWyD), it is auto-calculated when LMP or EDD is entered (only in OB Exam).
- EDD: Estimated Date of Delivery (yyyy/mm/dd or mm/dd/yyyy), if EDD is entered then GA is

calculated. An A GA more than 42W6D days is considered invalid.

- Fetus: Enter 1 up to 4 for multiple gestations.
- G/P/A: G stands for Gravida, P stands for Para and A stands for Aborta. Enter values for each in the fields separated by slashes.
- Study Description: enter the study description.
- Height: Enter the patient's height. The units can be set in the Patient section of Setup.
- Weight: Enter the patient's weight. The units can be set in the Patient section of Setup.
- BSA: Body Surface Area, it is auto-calculated and displayed when Height/Weight is entered.
- HR: Enter the Heart Rate.
- BP: Enter the Blood Pressure.
- PSA: Prostate Specific Antigen.
- PPSA Coefficient: Predicted Prostate Specific Antigen.
- Ref. Physician: Enter the name of the Ref.Physician.
- Dx. Physician: Enter the name of the Dx.Physician.
- Operator: Enter the name of the person performing the exam.
- CPT code: Current Procedural Terminology code.
- <Custom field 1>: Enter the user-defined data.
- <Custom field 2>: Enter the user-defined data.
- Comments: Enter any additional comments.

While the Patient Information Page is displayed the following buttons are displayed on the touch screen and Patient Information Page:

- Press **Start Exam** to exit the Patient Page function and return to B-mode imaging with the newly entered demographic data for the active exam.
- Press **Cancel** to exit the Patient Information Page without storing any of the entered data.
- Press **Clear All** to clear all of the demographic fields except for name and ID.
- Input LMP, and press **Prior Exam** to enable the entry of previous OB exam data for fetal trending details. This option is only available when an OB preset is selected.

## 4.5 Modality Worklist

Modality worklist provides a list of scheduled patients derived from a DICOM server. It is available only when a DICOM server is configured and worklist is enabled.

When the modality worklist function is enabled and configured in DICOM Connectivity screen, the worklist is shown to the left of the Patient Information Page, as shown below.

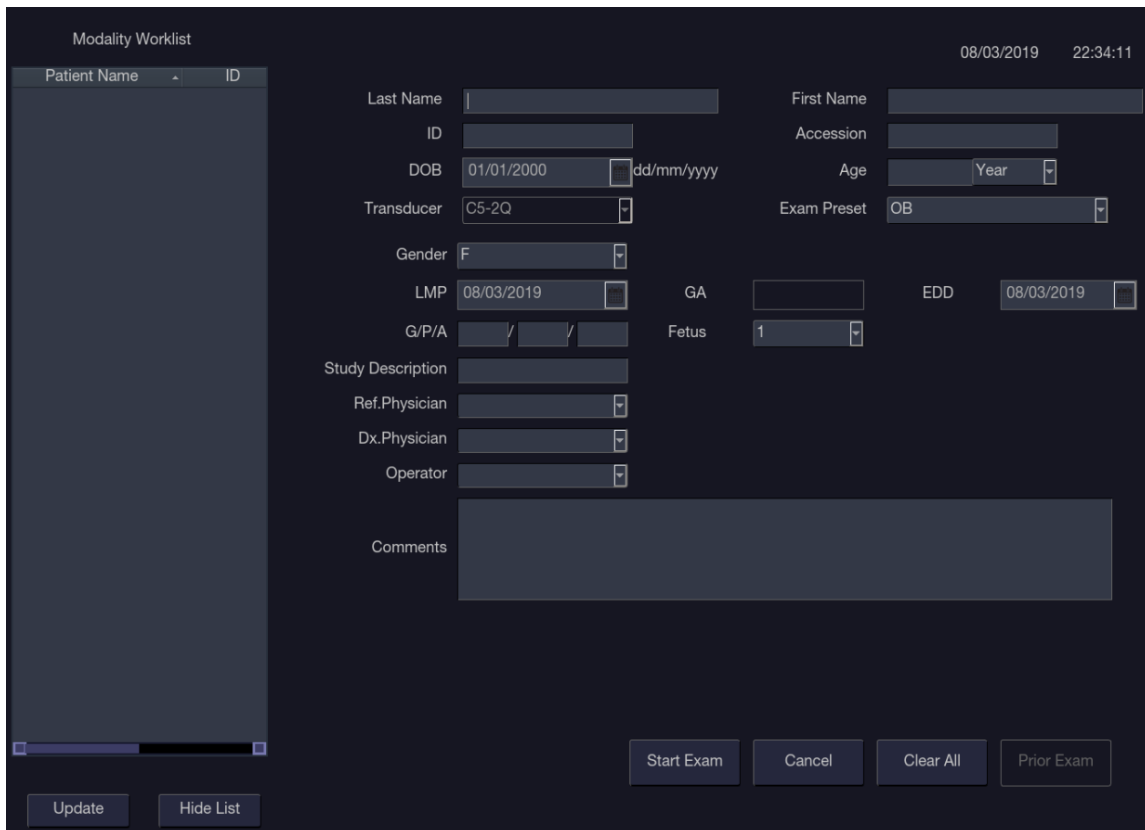


Figure 4-4 Modality Worklist Display

The worklist is displayed at the left side of the Patient Information Page in two columns labeled patient name and patient ID. Clicking on the header of each column will sort the list for the corresponding column.

The worklist shows all scheduled ultrasound exams within the date-range specified in the Connectivity Utility (See 11.2.2). Typing any text in the Patient Name or ID fields will filter the list to exams that contain the entered text.

**Update:** Press to query the patient data and update the list manually.

**Hide List:** Press to hide the list with only a **Show List** button displayed. Press the **Show List** button to display the list and other buttons.

Select one patient from the list and the detailed patient information is entered into the associated fields on the patient information page, with the option to edit or complete. Then press **Start Exam** on the touch screen to start an exam.

# 5 Imaging

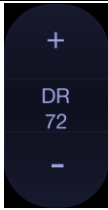

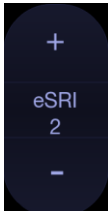
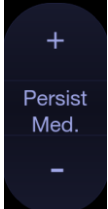


## 5.1 B-mode


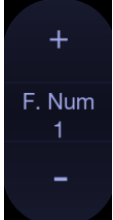
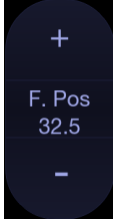
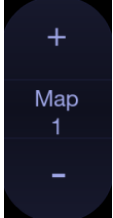
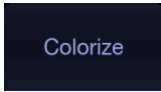
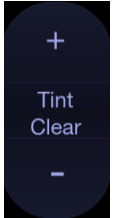
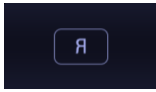
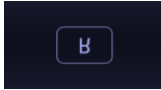
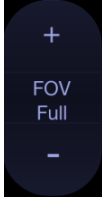
### 5.1.1. Using B-mode

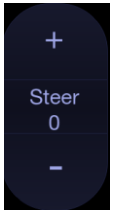
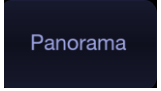
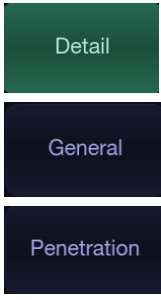
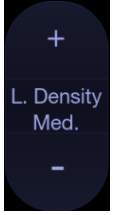
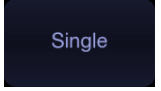
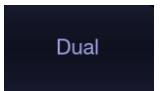
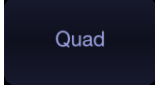

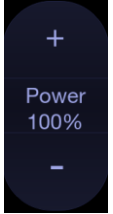
1. Press <B> on the console to enter B mode.
2. Perform the image scanning.
3. Adjust Image parameters to optimize the image.

### 5.1.2. B-mode Image Optimization

The following touch controls can be used to optimize the B-mode image.

Name	Control	Description
Dynamic Range		The Dynamic Range, or log compression, adjusts how echo intensities are converted to brightness. A high dynamic range will display more shades of gray, while a low dynamic range will display fewer shades of gray and a more contrasty image.
LGC		Lateral Gain Control (LGC) adjusts the gain along the scan line to improve the lateral resolution of the image. Press <b>LGC</b> touch screen key to display 8 gain control sliders. Move the slider downwards to decrease the gain, while move the slider upwards to increase the gain.
eSRI		eSRI is Speckle Reduction Imaging. High level provides more aggressive speckle reduction.
Persistence		Persistence averages frames together to reduce random noise. There are 4 options: Off, Low, Med., and High. The persistence level corresponds to the number of frames averaged. The frame rate is unchanged.
Frequency		Frequency allows selection of the fundamental or harmonic frequencies used for imaging. The Harmonic option must be invoked to access the harmonic frequencies. Frequency selection is available during live imaging.
Harmonic		The Harmonic control invokes and exits harmonic imaging. While in harmonic imaging the control is highlighted and an 'H' is displayed in the B-mode frequency field. Depending on the transducer there may be multiple harmonic frequencies.

Spatial Compounding		<p>Spatial Compounding combines images fired from multiple angles to reduce speckle, reduce shadow artifacts, and enhance contrast. Spatial compounding is an on/off control.</p>
Focus Number		<p>Focus Number adjusts the number of foci is displayed. As the number of foci increases, image uniformity across depth will increase, but the frame rate will decrease.</p>
Focus Position		<p>Focus Position adjusts the depth of the focus or foci. Upward presses move the focus shallower, regardless of the U/D invert status of the image.</p>
Gray Map		<p>Gray Map adjusts the post processing map used on the B-mode image. In general, higher map numbers correspond to more contrast in the image.</p>
Colorize		<p>The Colorize control adds a color tint to the B-mode image.</p>
Tint		<p>The Tint control changes the color tint being used. If Colorize had been off, changing the Color map control will automatically activate it.</p>
Left/Right		<p>The Left/Right invert control is indicated by a backward R and is used to toggle the left/right orientation of the image. The Edan E orientation marker at the top of the image switches with the left/right invert to match the orientation marker on the transducer.</p>
Up/Down		<p>The Up/Down invert control is indicated by an upside-down R and is used to toggle the up/down orientation of the image. The TGC curve is also re-oriented with Invert On, so that the top of the TGC curve corresponds to the top of the image on the screen.</p>
FOV		<p>The Field of View control adjusts the image width. Full, Large, Med. and Small settings are available. As the image becomes narrower, the frame rate increases.</p>

Steer		The Steer control is only available for linear transducers and steers the B-mode image left or right, without moving the transducer. This function can be particularly useful when visualizing needles or other objects that are enhanced by a perpendicular beam. Steer is not available if Spatial Compounding, Extended FOV or Panorama is turned on.
Panorama		The Panorama control invokes the Panorama function. See section 5.10 for details.
Image Type		B-mode supports presets for Detail, General, and Penetration.
Line Density		Adjusts the line density to optimize the lateral resolution for the best possible image. The higher the line density, the higher the lateral resolution, but the lower the frame rate.
Single		Press to display the currently active side of Dual image as a single image.
Dual		Press to activate dual imaging mode. See section 7.3.1 <i>Dual Imaging</i> for details.
Quad		Press to activate quad imaging mode. Refer to section 7.3.2 <i>Quad Imaging</i> for details.
3D/4D		Press to activate 3D/4D imaging mode. Refer to section 5.9 <i>3D/4D mode</i> for details.
Acoustic power		Adjusts the acoustic output power of the activate transducer. It is only available in live imaging. Higher acoustic power numbers correspond to increased sensitivity in the image with improved penetration, but the ALARA principle should be followed in actual clinical situations.

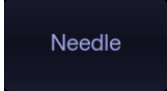
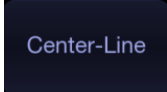
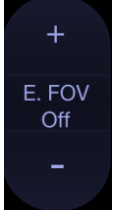
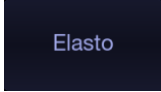
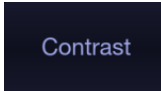
Needle		Press to invoke the touch screen for Needle Enhancement Visualization and Needle Biopsy Guide functions. See section 6.4 and 6.5 for more information.
Center Line		Press to activate the Center Line function. Refer to section 6.6 for details.
Extended FOV		Press to invoke extended field of view function. Only available for linear transducers. The extended field of view function displays as trapezoid imaging, and its imaging width is adjustable with three levels. Off is to disable the extended field of view function.
Elastography		Press to invoke Elastography mode. Refer to section 5.11 for details.
Contrast		Press to invoke Contrast Imaging mode. Refer to section 5.12 for details.

Table 5-1 B-mode Touch Screen Controls

## 5.2 Color Mode

### 5.2.1. Color Mode Variants

The system supports 3 types of Color Doppler imaging:

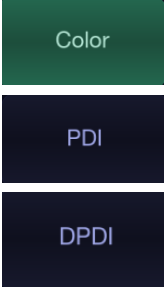

- Color (Color Doppler): This is velocity Color Doppler that shows direction and velocity of flow. Different colors represent different velocities and positive flow has different colors than negative flow.
- PDI (Power Doppler Imaging): PDI shows the power, or intensity, of the Doppler signal. PDI is typically more sensitive to low levels of flow, but cannot distinguish the velocity or direction of the flow.
- DPDI (Directional Power Doppler Imaging): This is similar to DPI in that it shows the power of the Doppler signal instead of the velocity. However, it does map positive flow to different colors than negative flow.

### 5.2.2. Using Color Mode

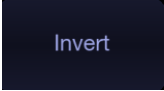
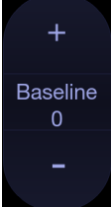
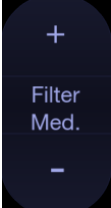
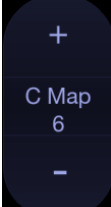
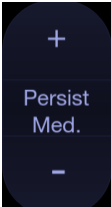
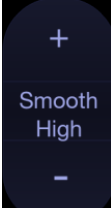
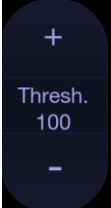
1. Perform the image scanning to get a good image in B mode;
2. Press <C> to enter B+Color mode and display ROI box;
3. Adjust the size and position of ROI box.  
Presses on <Set> switch between the status of adjusting the size and position of ROI box. Use trackball to adjust.
4. Press **PDI**, **DPDI** or **Color** mode key on the touch screen to switch Color Doppler modes when necessary;
5. Adjust image parameters to optimize the Color image.

### 5.2.3. Color Image Optimization

The following touch controls can be used to optimize the Color image.

Name	Control	Description
Color Mode Variation		A set of radio-buttons display the color modes that are available on the current transducer, and let you switch between them. See section 5.2.1 for details.
Scale		Scale adjusts the range of velocities that are displayed. Upward presses increase scale and downward presses decrease it. It is available in Velocity, PDI, and DPDI. It is not available in Freeze/Cine.



<p>Invert</p>		<p>Normally, signals above the baseline are positive velocities (moving toward the transducer). However, when Invert is pressed then negative velocities are above the baseline. Invert does not affect the baseline position. Invert is not available in PDI mode.</p>
<p>Baseline</p>		<p>The Baseline control adjusts the Color baseline. Upward presses move the baseline up on the scale and downward presses move the baseline down. Baseline is not available in PDI mode.</p>
<p>Wall Filter</p>		<p>The Filter control removes excessive noise from movement of vessel walls. Options of Low, Med and High are available.</p>
<p>Map</p>		<p>Adjusts the current map for the active color variation.</p>
<p>Persist</p>		<p>Persistence determines the number of frames that are averaged together for display. Levels of Off, Low, Med and High are available.</p>
<p>Smooth Filter</p>		<p>The smoothness filter determines the spatial filtering that is applied to the Color image. Higher filter levels create a smoother image. Upward presses increase the filter. Downward presses decrease the filter.</p>
<p>Threshold</p>		<p>When the system receives both B-mode and color signals from a region within the Color ROI box, the Threshold determines whether to display overlapping signals as grayscale or color.</p> <p>In Color mode, higher Threshold values display more color, and lower Threshold values display more grayscale.</p> <p>In TDI mode, higher Threshold values display more grayscale, and lower Threshold values display more color</p> <p>Upward presses increase threshold. Downward presses decrease threshold.</p>

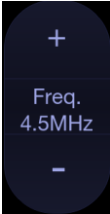
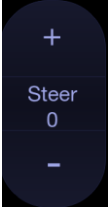
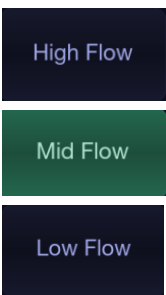
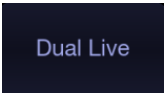
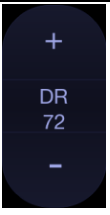
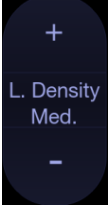
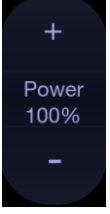
Frequency		Frequency determines the transmit frequency used by color Doppler. Upward presses increase the frequency. Downward presses decrease the frequency.
Steer		This control is only available for linear transducers. It steers the Color ROI box angle left or right.
Image Type		Color Doppler supports image presets for Low Flow, Medium Flow, and High Flow.
Dual Live		To activate split screen with simultaneous live B/Color and live B. The live B image without color and the same live B image with color are simultaneously displayed on each side of the image field. Freezing the image will freeze both sides simultaneously. Cine review will review both sides simultaneously.
Dynamic Range		The Dynamic Range, or log compression, adjusts how echo intensities are converted to brightness. A high dynamic range presents a flatter, less contrasty color display, while a low dynamic range presents a more contrasty color display. Only available in PDI/DPDI mode.
Line Density		Adjusts the line density to optimize the lateral resolution for the best possible image. The higher the line density, the higher the lateral resolution, but the lower the frame rate.
Acoustic power		Adjusts the acoustic output power of the activated transducer. It is only available in live imaging. Higher acoustic power numbers correspond to increased color sensitivity and penetration, but the ALARA principle should be followed in actual clinical situations.

Table 5-2 Color Mode Touch Screen Controls


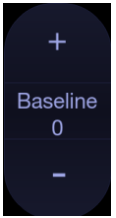
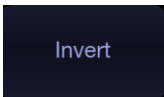

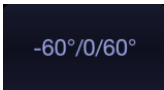
## 5.3 PW Mode

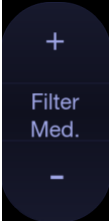
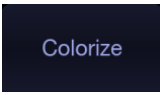
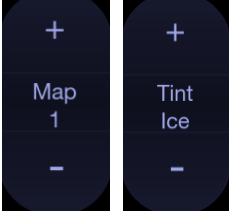
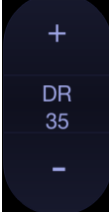

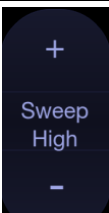
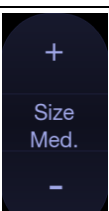
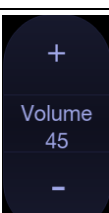
### 5.3.1. Using PW Mode

1. Perform the image scanning to get a good image in B mode or B+Color(DPI/DPDI) mode;
2. Press <PW> on the console to display sample line;
3. Use the trackball and touch controls to adjust the position of the sample line and the size and angle of the sample gate;
4. Press <PW> on the console to enter B+PW or B+Color(PDI/DPDI)+PW mode and display Doppler strip.
5. Adjust image parameters to optimize the Doppler strip.
6. When spectrum is displayed, pressing <Update> toggles between acquiring the Doppler strip and acquiring the reference image.

### 5.3.2. PW Image Optimization

The following touch controls can be used to optimize the PW image.

Name	Control	Description
Scale		Scale adjusts the range of velocities that are displayed. Upward presses increase scale and downward presses decrease scale. Increasing scale when the PW cursor is relatively deep may result in invoking HPRF, if it is configured. See section 5.2.2 for details.
Baseline		The Baseline control adjusts the Doppler baseline. Upward presses move the baseline up on the screen and downward presses move the baseline down.
Invert		Normally, signals above the baseline are positive velocities (moving toward the transducers). However, when Invert is pressed, the negative velocities are displayed above the baseline. Invert does not affect the baseline position.
Angle Correct		Adjust the Doppler scale to account for the angle between the Doppler cursor and the blood flow. Upward presses increment the angle. Downward presses decrement the angle. Angles above 80 are not allowed.
Quick-Angle		Adjusts the angle correct quickly to one of 60/0/-60.

<p>Filter</p>		<p>The Filter control removes excessive noise from movement of vessel walls. Options of Low, Med and High are available. Higher wall filter level will suppress more strong single of the vessel walls, but low flow signal will be missing.</p>
<p>Colorize</p>		<p>Switches between grayscale and colorized (pseudo-color) postprocessing maps.</p>
<p>Gray Map Tint</p>		<p>Adjusts the current postprocessing, either grayscale or tinted</p>
<p>Dynamic Range</p>		<p>The Dynamic Range, or log compression, adjusts how signal intensities are converted to brightness. A high dynamic range will display more shades of gray, while a low dynamic range will display fewer shades of gray and a more contrasty Doppler display.</p>
<p>SV Size/Gate Size</p>		<p>Gate adjusts the size of the sample volume gate. Upward presses increase the gate size. Downward presses decrease the gate size.</p>
<p>Sweep Speed</p>		<p>Sweep adjusts the sweep speed of the Doppler strip. Options of Slow, Low, Med, High and Fast are available. Upward presses increase sweep speed. Downward presses decrease sweep speed.</p>
<p>Strip Size</p>		<p>Changes the relative size of the Doppler strip compared to the reference image. Full, Large, Med. and Small are available.</p>
<p>Volume</p>		<p>Volume adjusts the audio volume of the Doppler strip. This can be adjusted in pre-Doppler to set the initial volume upon invoking Doppler acquisition.</p>

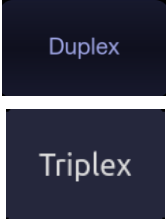
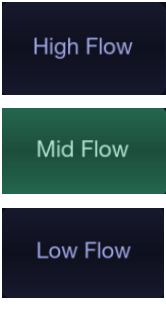
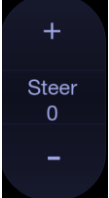
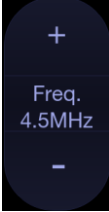
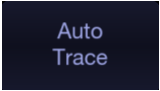

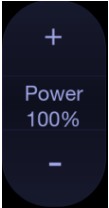
<p>Duplex (Triplex)</p>		<p>This determines if the strip mode and reference image are imaging simultaneously or not. In Duplex mode, either the Doppler strip or the reference image is updated continuously. In Triplex mode, both the Doppler strip and reference image are updated simultaneously.</p>
<p>Image Type</p>		<p>Spectral Doppler supports image presets for Low Flow, Medium Flow and High Flow.</p>
<p>Steer</p>		<p>This control is only available for linear transducers and steers the Doppler cursor angle left or right.</p>
<p>Frequency</p>		<p>This determines the Doppler transmit frequency used for imaging.</p>
<p>Auto Trace</p>		<p>Press to activate the Auto Trace function on a real-time or frozen PW Doppler strip. The Auto Trace function automatically traces the spectral Doppler waveform and records several measurements on selected waveforms.</p>
<p>Auto Trace Direction</p>		<p>Press one of the three options to specify which side of the Doppler baseline to take measurements from: <b>Up</b>: traces positive portion of waveform (above baseline). <b>Down</b>: traces negative portion of waveform (below baseline). <b>Both</b>: traces waveform on both sides of baseline.</p>
<p>Acoustic power</p>		<p>Adjusts the acoustic output power of the activated transducer. It is only available in live imaging. Higher acoustic power numbers correspond to increased sensitivity in the Doppler display and improved penetration, but the ALARA principle should be followed in actual clinical situations.</p>

Table 5-3 PW Mode Touch Screen Controls

### 5.3.3. HPRF

Conventional PW Doppler scales are limited by the Nyquist limit. High Pulse Repetition Frequency (HPRF) allows the system to exceed the Nyquist limit by having multiple Doppler pulses in the body at the same time. In HPRF imaging, multiple Doppler gates are displayed since the multiple Doppler pulses could be giving information from different depths. HPRF is automatically invoked when needed to maintain the requested depth and scale. For example, if the system is at a high scale and you move the cursor deeper, the system may automatically invoke HPRF. This can also happen if the cursor is deep and you increase scale.

If HPRF is active, you will see multiple Doppler gates on the reference image. If you do not want to be in HPRF, decrease the scale or move the primary PW gate to a shallower location until only one gate is displayed.

## 5.4 CW Mode

### 5.4.1. Using CW Mode


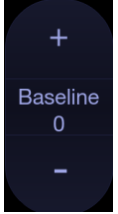
CW mode is only available on phased array transducer.

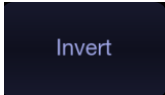
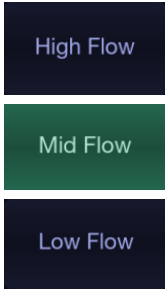

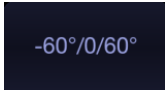
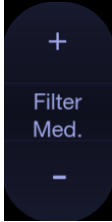
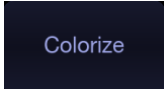
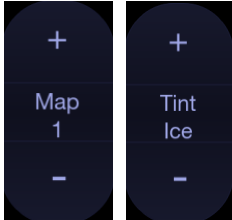
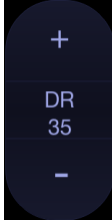
1. Perform the image scanning to get a good image in B mode or B+Color(DPI/DPDI) mode;
2. Press <CW> on the console to display sample line;
3. Use the trackball and touch controls to adjust the position of the sample line;
4. Press <CW> on the console to enter B+CW or B+Color(PDI/DPDI)+CW mode and display Doppler strip.
5. Adjust image parameters to optimize the Doppler strip.
6. When spectrum is displayed, pressing <Update> toggles between acquiring the Doppler strip and acquiring the reference image.

In CW mode, pressing on <PW> on the console will switch PW mode directly.

### 5.4.2. CW Image Optimization

The following touch controls can be used to optimize the CW image.

Name	Control	Description
Scale		Scale adjusts the range of velocities that are displayed. Upward presses increase scale and downward presses decrease it.
Baseline		The Baseline control adjusts the Doppler baseline. Upward presses move the baseline up on the screen and downward presses move the baseline down.

<p>Invert</p>		<p>Normally, signals above the baseline are positive velocities (moving toward the transducer). However, when Invert is pressed then negative velocities are above the baseline. Invert does not affect the baseline position.</p>
<p>Image Type</p>		<p>Strip Doppler supports image presets for Low Flow, Medium Flow, and High Flow.</p>
<p>Angle Correct</p>		<p>Adjust the Doppler scale to account for the angle between the Doppler cursor and the blood flow. Upward presses increment the angle. Downward presses decrement the angle. Angles above 80 are not allowed.</p>
<p>Quick-Angle</p>		<p>Adjusts the angle correct quickly to one of 60°/0°/-60°.</p>
<p>Filter</p>		<p>The Filter control removes excessive noise from movement of vessel walls. Options of Low, Med and High are available. Higher wall filter level will suppress more strong single of the vessel walls, but low flow signal will be missing.</p>
<p>Colorize</p>		<p>Switches between grayscale and tinted (pseudo-color) postprocessing maps.</p>
<p>Gray Map Tint</p>		<p>Adjusts the current postprocessing, either grayscale or tinted.</p>
<p>Dynamic Range</p>		<p>The Dynamic Range, or log compression, adjusts how signal intensities are converted to brightness. A high dynamic range will display more shades of gray, while a low dynamic range will display fewer shades of gray and a more contrasty Doppler display.</p>

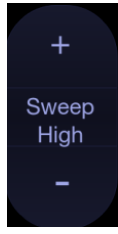
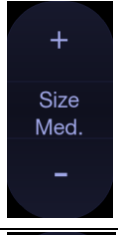
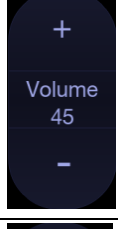
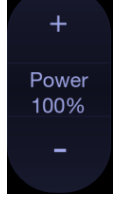
Sweep Speed		Sweep adjusts the sweep speed of the Doppler strip. Options of Slow, Low, Med, High and Fast are available. Upward presses increase sweep speed. Downward presses decrease sweep speed.
Strip Size		Changes the relative size of the Doppler strip compared to the reference image. Full, Large, Med. and Small are available.
Volume		Volume adjusts the audio volume of the Doppler strip. This can be adjusted in pre-Doppler to set the initial volume upon invoking Doppler acquisition.
Acoustic Power		Adjusts the acoustic output power of the activated transducer. It is only available in live imaging. Higher acoustic power numbers correspond to increased sensitivity in the Doppler display and improved penetration, but the ALARA principle should be followed in actual clinical situations.

Table 5-4 CW Mode Touch Screen Controls

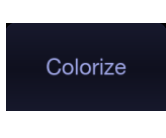
## 5.5 M Mode

### 5.5.1. Using M Mode

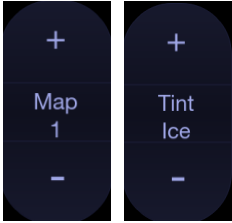
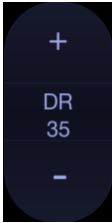
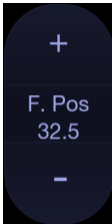
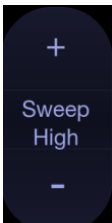
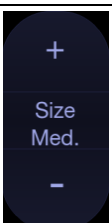
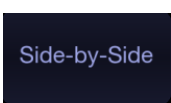
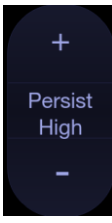

1. Perform image scanning to get a good image in B mode;
2. Press **<M>** to display M strip and sample line;
3. Move the trackball to adjust the sample line;
4. Adjust image parameters to optimize M strip.

### 5.5.2. M-mode Image Optimization

The following touch controls can be used to optimize the M-mode image.

Name	Control	Description
Colorize		Switches between grayscale and colorized (pseudo-color) postprocessing maps.



<p>Gray Map Tint</p>		<p>Adjusts the current postprocessing, either grayscale or tinted.</p>
<p>Dynamic Range</p>		<p>The Dynamic Range, or log compression, adjusts how echo intensities are converted to brightness. A high dynamic range will display more shades of gray, while a low dynamic range will display fewer shades of gray and a more contrasty M-mode display.</p>
<p>Focus Position</p>		<p>The focus position set in B-mode applies to M-mode as well. Upward presses move the focus shallower, regardless of the U/D invert status of the M-mode. Downward presses move the focus deeper.</p>
<p>Sweep Speed</p>		<p>Sweep adjusts the sweep speed of the M-mode strip. Options of Slow, Low, Med, High and Fast are available. Upward presses increase sweep speed. Downward presses decrease sweep speed.</p>
<p>Strip Size</p>		<p>Changes the relative size of the M-mode strip compared to the reference image. Full, Large, Med and Small are available.</p>
<p>Side-by-side</p>		<p>This is an on/off control. When On, the M-Mode strip is displayed side-by-side with the B-mode image. When Off, the M-Mode strip is displayed below the B-mode image</p>
<p>Line Persistence</p>		<p>The line Persistence determines how many M-mode lines are averaged together for the display (similar to persistence in B-Mode). Off, Low, Med and High settings are available.</p>
<p>Frequency</p>		<p>Frequency determines the transmit frequency used by M-Mode. Upward presses increase the frequency. Downward presses decrease the frequency.</p>

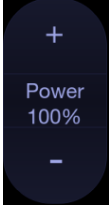

Acoustic power		Adjusts the acoustic output power of the activated transducer. It is only available in live imaging. Higher acoustic power numbers correspond to increased sensitivity and penetration in the image, but ALARA principle should be followed in actual situations.
Anatomic M		Invokes Anatomic M mode.

Table 5-5 M-Mode Touch Screen Controls

## 5.6 Anatomic M Mode

Anatomic M mode allows you to manipulate the position and angle of M sample line and displays real-time M strip image. Only phased array transducer supports Anatomic M mode.

### 5.6.1. Using Anatomic M Mode

1. Press **Anatomic** button on the M-mode touch screen to invoke Anatomic M mode.
2. Press **Show one**, **Show two** or **Show three** button on the touch screen to display single or multiple M sample lines.
3. Use trackball to adjust the position of M sample line.
4. Press **Angle** button on the touch screen or rotate **<Angle>** knob on the console to adjust the angle of M sample line.

If multiple M sample lines are displayed pressing **<Set>** key can switch between the M sample lines.

5. Adjust image parameters to optimize M strip.

### 5.6.2. Anatomic M Image Optimization

For touch screen controls consistent with those in M mode, please refer to section 5.5.2 M-mode Image Optimization. This section only introduces special touch screen controls in Anatomic M mode.

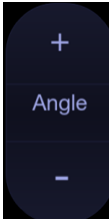
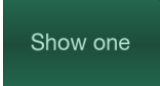
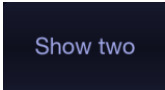
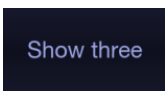
Name	Control	Description
Angle		Adjusts the angle of M sample line.
M sample lines		Displays only one M sample line.
		Displays two M sample lines.
		Displays three M sample lines.

Table 5-6 Anatomic M Mode Touch Screen Controls

## 5.7 Color M Mode

Color M mode superimposes color encoded information on M mode strip to indicate the direction, velocity and timing of cardiac flow and tissue movements. The direction of cardiac tissue movements can be identified by color changes.

The Color M mode includes Color Flow M mode and Color Tissue M mode.

### 5.7.1. Using Color M Mode

1. Enter Color M mode
  - Enter Color Flow M mode
    - In B+M mode, press <C> key;
    - In B+Color mode, press <M> key to display M sample line, and then press <M> key again.
    - In B+Color+PW or B+Color+CW mode, press <M> key.
  - Enter Color Tissue M mode
    - In Color Flow M mode, press **TDI** key on the touch screen.
    - In Color-TDI mode, press <M> key.

Note:

Only phased array transducer supports Color Tissue M mode.

2. Adjust the position of ROI box or M sample line.
3. Adjust image parameters to optimize the image.

### 5.7.2. Color M Image Optimization

Touch screen controls that can be adjusted in Color M mode are the same as those in B mode, Color mode and M mode, see section 5.1.2, section 5.2.3 and section 5.5.2 for details.

## 5.8 TDI Mode

Tissue Doppler Imaging (TDI) mode shows information about low-velocity and high-amplitude tissue motion, usually used to evaluate cardiac tissue motion. Only Phased transducer supports TDI mode.

There are two types of TDI modes available on this system:

- Color-TDI mode: shows the speed and direction of tissue motion on real-time Color image.
- PW-TDI mode: shows the speed of tissue motion on Strip Doppler image.

### 5.8.1. TDI Mode Operations

#### **To use Color-TDI mode:**

1. Press <**C**> key on the console.
2. Press **TDI** key on Color-mode touch screen to invoke Color-TDI mode.
3. Use the trackball to adjust the position of ROI box.

While in Color-TDI mode, you can do the follows to invoke PW-TDI mode:

1. Press <**PW**> key on the console and use the trackball to move the sample volume gate to desired position.
2. Press <**PW**> key or <**Update**> key on the console to invoke PW-TDI mode.

#### **To use PW-TDI mode:**

1. Press <**PW**> key on the console and use the trackball to move the sample volume gate to desired position.
2. Press **TDI** key on the touch screen to invoke PW-TDI mode.

### 5.8.2. TDI Touch Screen Controls

Touch screen controls that can be adjusted in Color-TDI mode are the same as those in Color mode, see section 5.2.3 Color Image Optimization for details. Touch screen controls that can be adjusted in PW-TDI mode are the same as those in PW mode, see section 5.3.2 PW Image Optimization for details.

## 5.9 3D/4D Mode

3D/4D mode is only available on a Wobble transducer. There are two ways to activate pre-3D or Pre-4D mode:

1. Press the <3D> or <4D> on the console.
2. Press the 3D or 4D button on the touch screen in B-mode.

### 5.9.1. Pre-3D/Pre-4D

The Pre-3D and Pre-4D mode supports defining the 3D and 4D acquisition location and settings. Figure 5-2 shows an example of the pre-3D image.

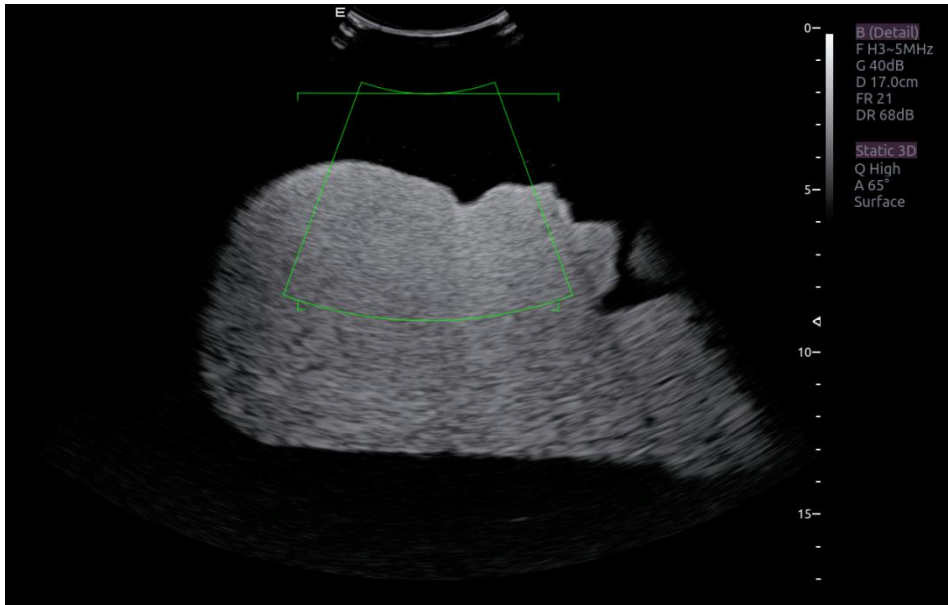


Figure 5-1 Pre-3D Image

The VOI (Volume of Interest) indicates the portion of the image that will be used for 3D. The top horizontal line is the clip plane. The initial volume rendering will show everything below this line. It can be adjusted to a curved line upwards and downwards and its top point can be adjusted to left or right by using the trackball. Also the position/size of the VOI can be adjusted using the trackball. Press <Set> key to toggle among VOI position, VOI size and horizontal line adjusting.

The touch screen controls in Pre-3D and Pre-4D:

Name	Control	Description
Image Quality		Adjusts the trade-off between speed and image quality of the acquisition. Settings include High (quality), Middle, and Fast.
Angle		Adjusts the angle of the volume acquisition. Upward presses increment the angle. Downward presses decrement the angle.

Surface/ Skeleton	<div style="background-color: #1a202c; color: white; padding: 2px; margin-bottom: 2px; text-align: center;">Skeleton</div> <div style="background-color: #2e7d32; color: white; padding: 2px; margin-bottom: 2px; text-align: center;">Surface</div>	These two radio buttons determine if the acquisition is optimized for looking at Skeleton or Surface.
3D	<div style="background-color: #1a202c; color: white; padding: 2px; text-align: center;">3D</div>	Displayed in Pre-4D. Press to switch to Pre-3D.
4D	<div style="background-color: #1a202c; color: white; padding: 2px; text-align: center;">4D</div>	Displayed in Pre-3D. Press to switch to Pre-4D.
Start	<div style="background-color: #1a202c; color: white; padding: 2px; text-align: center;">Start</div>	Start an acquisition.
Exit	<div style="background-color: #1a202c; color: white; padding: 2px; text-align: center;">Exit</div>	Exit 3D/4D

Table 5-7 Pre-3D Touch Screen

### 5.9.2. 3D Volume Sweeping

Select **Skeleton** or **Surface** on the Pre-3D touch screen and press **Start** button or <Update> key to start image acquisition.

During the process of 3D volume sweeping, the images swept in VOI box are displayed in the image area.

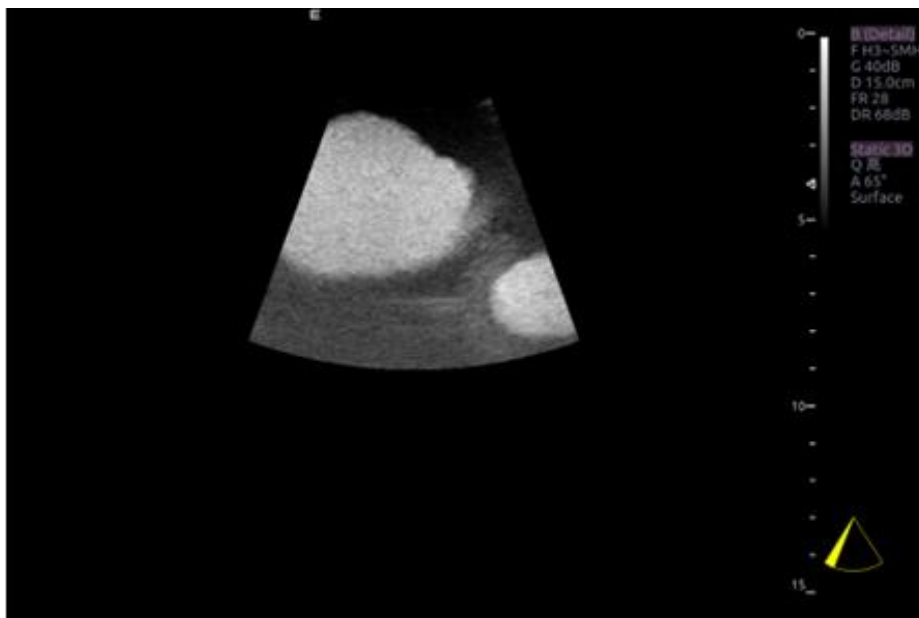



Figure 5-2 3D Image Scanning

While scanning, the sector  in the right bottom is filled gradually, and no buttons on the control panel and touch screen can be activated.

### 5.9.3. 3D Image Review

The system will enter to the 3D review status after finishing one sweep.

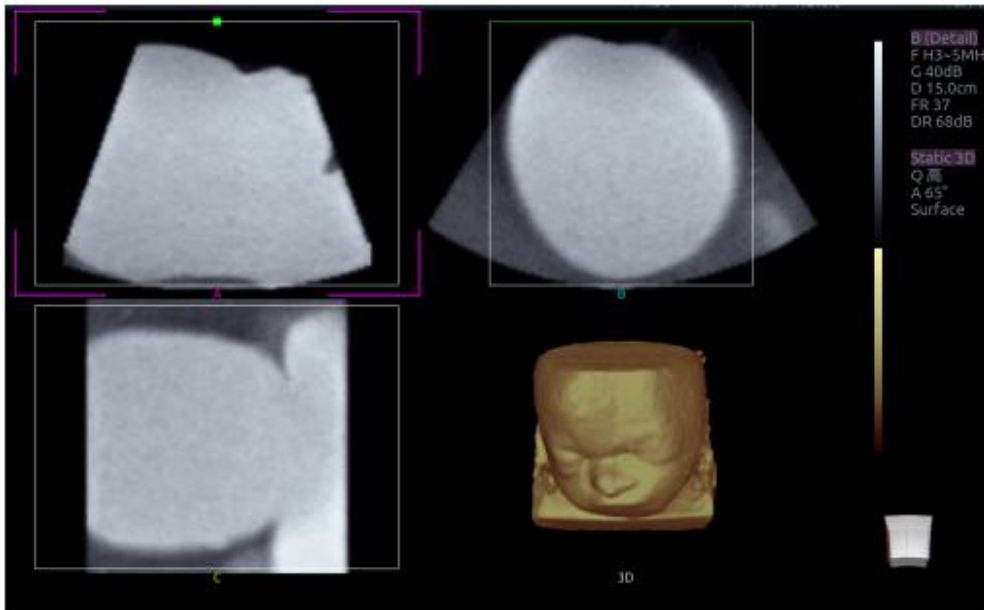


Figure 5-3 3D Image Review

There are two image modes: Volume imaging mode and multi-slice imaging mode. Figure 5-3 shows Volume Imaging Mode in quad screen with a Baby Face volume rendering.

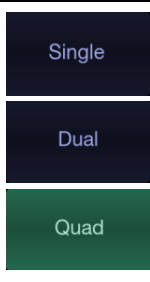

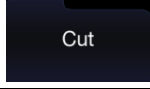


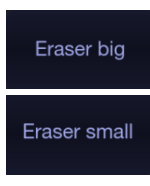
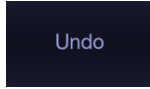
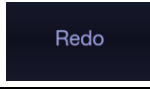
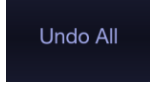
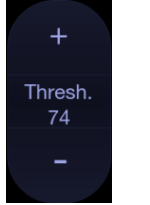
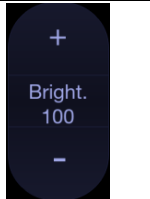
- Quadrant A shows a slice through the data that mimics the original ultrasound image.
- Quadrant B is orthogonal to A, as if the transducer had been rotated 90 degrees.
- Quadrant C is orthogonal to A and B, showing a slice that is parallel to the transducer face.



The icon at the bottom-right shows the position of each slice with respect to the full 3D data set.

The following table shows the touch screen controls that are available in Volume Imaging Mode

Name	Control	Description
Volume/ Multi-slice	<input checked="" type="radio"/> Volume <input type="radio"/> Multi-Slice	These two radio buttons toggle between the Volume display and the Multi-Slice display.
A/B/C/3D	<input checked="" type="radio"/> A <input type="radio"/> B <input type="radio"/> C <input type="radio"/> 3D	These four radio buttons select which quadrant is the focus of the navigation/panning controls. A/B/C are three orthogonal slices through the volume, while '3D' is the rendered image.
Reset	<input type="button" value="Reset"/>	Reset the operation of pan, rotate and zoom to the initial condition.

<p>Single, Dual, Quad</p>		<p>These three radio buttons switch the display to show 1, 2, or 4 images at once. Single shows the 3D image, dual shows the A slice and 3D image, Quad shows three MPR slices and 3D image.</p>
<p>VOI</p>		<p>Press to activate the function of adjusting VOI or clip plane. Use the trackball to adjust and press &lt;Set&gt; to switch between VOI and clip plane.</p>
<p>Cut</p>		<p>This is a folder of cut functions with various cut tools inside. See below for details.</p>
<p>Cut tools</p>		<p>These are two radio buttons. The region inside or outside the trace will be cut. To draw the trace, move the trackball and press &lt;Set&gt; to locate the start point, use trackball to draw trace and second press &lt;Set&gt; to locate the end point.</p>
		<p>These are two radio buttons. The region inside or outside the box will be cut. To draw the box, move the trackball and press &lt;Set&gt; to locate the top left point, move the trackball and a box is displayed. Press &lt;Set&gt; to locate the lower right point of the box.</p>
		<p>These two radio buttons switch the size of the eraser. To use eraser to cut, move the trackball and press &lt;Set&gt; to locate the first point, move the trackball and the path that the eraser moves is cut, and then press &lt;Set&gt; to complete the cut.</p>
<p>Undo</p>		<p>Undo the previous cut operation</p>
<p>Redo</p>		<p>Redo the previous undo operation</p>
<p>Undo All</p>		<p>Return to the condition before cutting</p>
<p>Threshold</p>		<p>Adjust the threshold of surface render mode, Upward presses increase threshold. Downward presses decrease threshold.</p>
<p>Brightness</p>		<p>Adjust the brightness of 3D image</p>



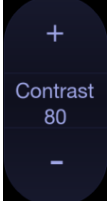
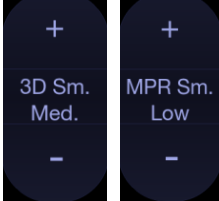
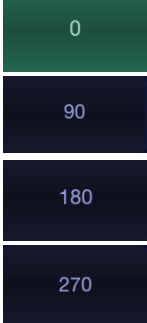

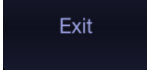

<p>Contrast</p>		<p>Adjust the contrast of 3D image.</p>
<p>3D Smooth MPR Smooth</p>		<p>Adjust smoothness of A\B\C slices and 3D images. Higher filter levels create a smoother image. Upward presses increase the filter. Downward presses decrease the filter.</p>
<p>Quick Rotation</p>		<p>Four radio buttons used to quickly rotate the image. Available angles are: 0°/90°/180° /270° .</p>
<p>New Volume</p>		<p>End the 3D volume sweeping and return to the pre-3D interface</p>
<p>Exit</p>		<p>Exit 3D</p>
<p>MPR Review</p>		<p>MPR (multi-planar reconstruction) review function. After this button is activated, the 3D volume is hidden and two perpendicular lines appear on the selected quadrant. These two lines are color matched with the other 2 MPR quadrants and show where the three planes intersect. Move trackball left/right or up/down to change location of lines and intersection on the MPR's. Moving one line will move the other perpendicular line.</p>
<p>3D Tint</p>		<p>Select 3D tint.</p>
<p>MPR Tint</p>		<p>Select MPR tint.</p>
<p>eFace</p>		<p>Press to show the baby face automatically. Only available in Surface render mode.</p>

Table 5-8 Volume imaging Mode Touch Screen

Image area and touch screen controls in multi-slice imaging mode:

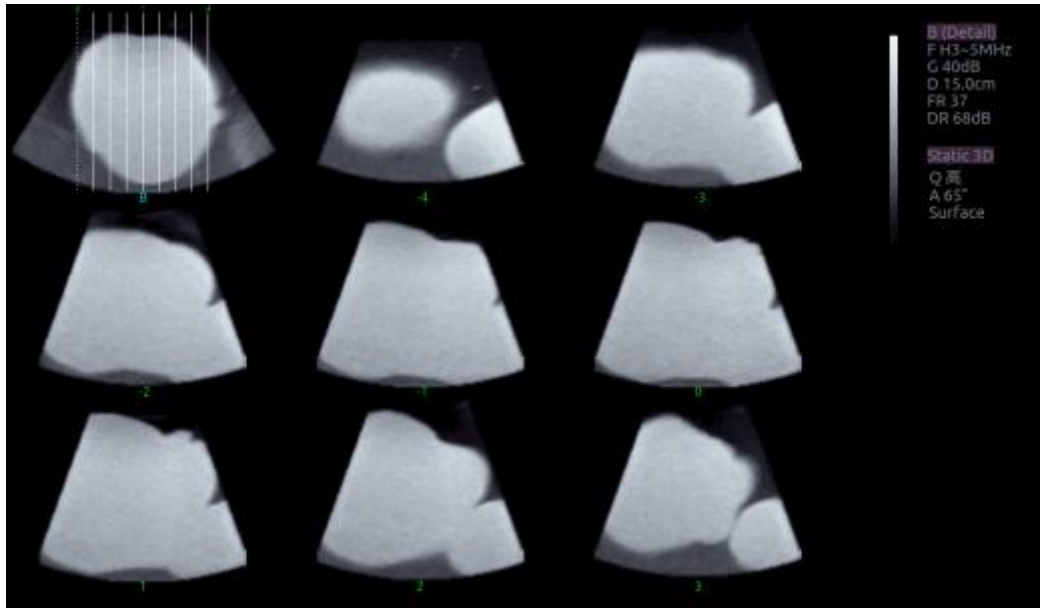


Figure 5-4 Multi-slice Imaging Mode

In figure 5-5, the first image shows the basis slice, other images are orthogonal to the basis slice and parallel to each other. Lines on the basis slice indicate the locations of the parallel slices. If there are more slices than images then the un-displayed slices are shown with a dotted line. A number below each parallel slice shows the slice location in the basis slice, with 0 being the middle slice.

Control	Name	Description
A/B/C	<input checked="" type="radio"/> A <input type="radio"/> B <input type="radio"/> C	These three radio buttons determine which slice is the required parallel slice. These three choices are the same as on the Volume display in quad mode.
3*3, 2*2, 3*2	<input checked="" type="radio"/> 2*2 <input type="radio"/> 3*2 <input type="radio"/> 3*3	These three radio buttons determine the layout of the display.
Reset	<input type="button" value="Reset"/>	Reset the operation of pan, rotate and zoom to the initial condition.
Number	<input type="button" value="+"/> Number 3 <input type="button" value="-"/>	Select how many slices to use

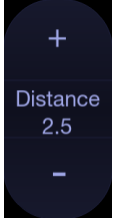
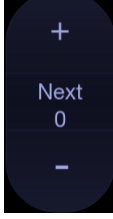

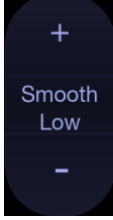
Distance		Adjust the distance between slices.
Next		When there are more slices than can be displayed at once this control cycles through the subset of slices displayed.
Tint		Select multi-slice tint.
Smooth		Adjust smoothness of A\B\C slices. Higher filter levels create a smoother image. Upward presses increase the filter. Downward presses decrease the filter.

Table 5-9 Multi-slice Mode Touch Screen

### 5.9.4. 4D Volume Acquisition

In Pre-4D mode, select **Skeleton** or **Surface** first, adjust the VOI box and then press **Start** button on the touch screen or the <Update> key to begin sweep.

### 5.9.5. 4D Live Volume

4D Live volume continuously sweeps and displays successive 3D volumes. As shown in figure below, image in the left is A slice and image in the right is the live 4D volume rendering

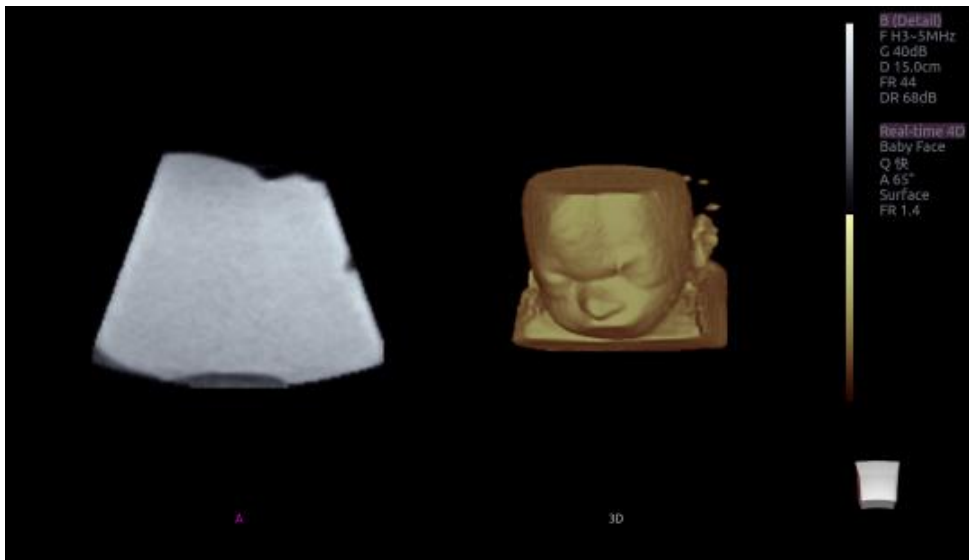


Figure 5-5 4D Volume Sweeping Image

### 5.9.6. 4D Cine

During the process of 4D live volume imaging, press the <Freeze> button on the control panel to enter the 4D cine mode. A cine replay scroll bar appears below the images. Use the trackball to replay the images. For the selected frame, user can execute all operations that are available in 3D review status. Press <Freeze> again to return to the live image.

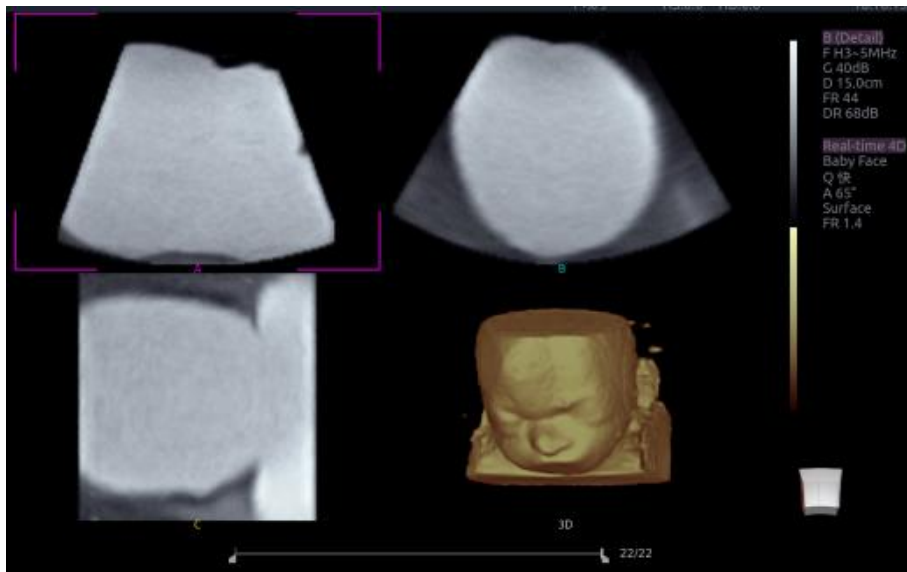


Figure 5-6 4D Cine

Touch screen controls are the same as that of static 3D except for Cine button.

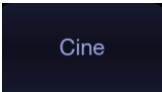
Name	Control	Description
Cine		Switch between 3D and 4D review state

Table 5-10 4D Touch Screen

### 5.9.7. Knobs and Buttons on Control Panel

Knobs and buttons on control panel can also be used to make operation more convenient in 3D/4D mode.





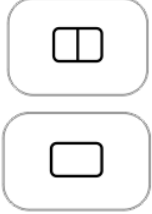
<b>Name</b>	<b>Control</b>	<b>Description</b>
Rotation X		Rotate this knob to rotate the basis slice by the X-axis of the activated window. Parallel slices change with the rotation operation.
Rotation Y		Rotate this knob to rotate the basis slice by the Y-axis of the activated window. Parallel slices change with the rotation operation.
Rotation Z		Rotate this knob to rotate the basis slice by the Z-axis of the activated window. Parallel slices change with the rotation operation.
Angle		Adjusts the angle of the volume acquisition.
Single, Dual		These two hard keys switch the display to show 1 or 2 images at once. Single shows the 3D image and dual shows the A slice and 3D image.

Table 5-11 3D/4D Mode Control Panel

## 5.10 Panorama

Panorama constructs an extended field of view image as the user slides the transducer along its long axis. Panorama is available only with Linear and Convex transducers.

This system also provides Color Panoramic imaging so that you can get color flow information on the panoramic image.

### **Caution**

1. The panoramic image is for reference only. Diagnosis must not be based on results achieved from panoramic image alone. The quality of panoramic image depends on sonographer's scanning techniques and experience, therefore affecting the measurement accuracy on a panoramic image.
2. Make sure enough coupling gel is applied along the scan path.
3. Always move the probe slowly and steadily during the scanning process.
4. Auto IMT measurement is not available on a panoramic image.

### **Acquiring panoramic image:**

1. Enter B or Color mode.
2. Press Panorama key on the touch screen to enter panoramic imaging mode.
3. Adjust image parameters to optimize the image.  
In Color Panoramic Imaging mode, pressing on **<Set>** key toggles between adjusting the size and position of ROI box. Roll the trackball to adjust.
4. Press the **<Update>** key to start acquisition.
5. Slide the transducer along its longitudinal axis. The image will extend to incorporate the newly imaged anatomy.
6. When the full anatomy has been acquired, press the **<Freeze>** hard key. System also will enter the panorama review state when exceeding the default time.

### **Speed Indicator**

During an acquisition, a speed indicator bar on the screen will show the current scan speed. Keep the indicator in the green center of the graphic in order to achieve best results.



Figure 5-7 Panorama Speed Indicator

### **Panoramic Image Review**

After acquisition, the system enters review status and the completed panoramic image is redisplayed to fit on the screen. In the review status, post-processing image optimization, Measurements, Comments and Body Marks are supported on the panoramic image.

## 5.11 Elastography

Elastography imaging maps the elastic properties of soft tissue with different colors in a region of interest by estimating the strain before and after tissue distortion caused by external or internal forces. Only linear transducers support Elastography.

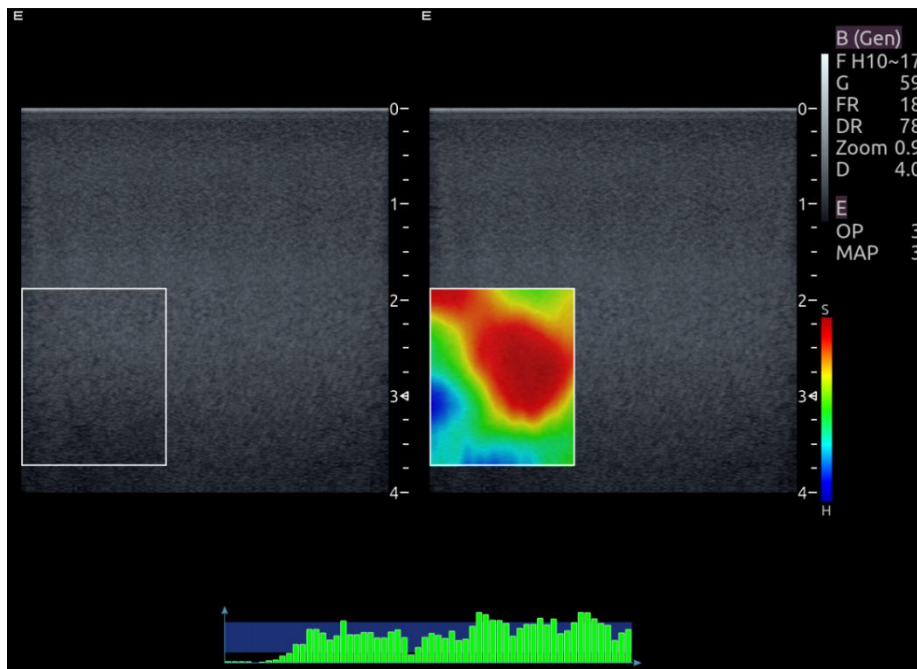
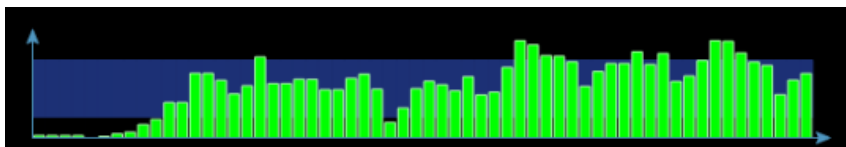


Figure 5-8 Example of Strain Elastography Display

### 5.11.1. Using Elastography Mode

#### To Use Elastography Mode:

1. Perform the scan in B mode and locate the lesion.
2. Press **Elasto** on the touch screen to invoke Elastography mode.
3. Adjust the size and position of ROI box if necessary.  
Use <Set> key to toggle between adjusting the position and the size. Use trackball to adjust.
4. Create a distortion in the tissue (eg. push the body surface with a transducer) according to clinic experiences while you are scanning the lesion. The strain pressure generated is indicated by the pressure curve in real-time at the bottom of display screen.



5. Press Freeze.

#### To Measure Strain Ratio:

Refer to Section 8.1.1 B-mode Generic Measurements for detailed steps of measuring Strain Ratio.

#### **Caution**

1. Proper pressure should be applied to the lesion when scanning according to the clinic situation and experience, otherwise misdiagnosis may result.
2. The ROI box should be adjusted to proper size and position, in which lesion and adequate normal tissue should be included for better diagnosis.

3. The Elastography image is for reference only. The image quality and measured results in Elastography mode always depend on the accuracy of the procedure performed. Any clinic diagnosis should be verified with other effective diagnosis methods.

### 5.11.2. Elastography Image Optimization

The following touch controls can be used to optimize the Elastography image.

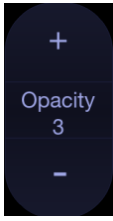
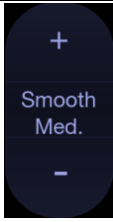
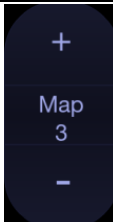
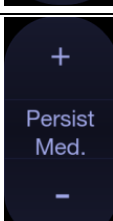
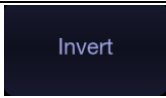
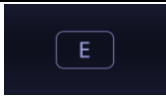


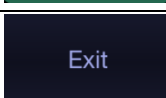
Name	Control	Description
Opacity		Adjusts the opacity feature of Elastography image. Four levels are available. Higher level provides more opacity.
Smooth		Adjusts smoothness of Elastography image. There are 4 options: Off, Low, Med., and High. Higher filter levels provide a smoother image.
Map		Adjusts the postprocessing map used on Elastography image.
Persistence		Persistence averages frames together to reduce random noise of Elastography image. There are 4 options: Off, Low, Med., and High. The persistence level corresponds to the number of frames averaged. The frame rate is unchanged; as each new frame is acquired, it is averaged with the preceding frames.
Invert		Inverts the Elastography color bar, and therefore inverts the colors of stiffer tissue and softer tissue.
Display formats		Only displays Elastography image.
		Displays an Elastography image below a B-mode image.
		Displays a B-mode image and an Elastography image side by side.
Exit		Exits Elastography mode.

Table 5-12 Elastography Touch Screen Controls



## 5.12 Contrast Imaging

Contrast Imaging is the application of ultrasound contrast agent to 2D Sonography. Injected contrast agents re-emit incident acoustic energy much more efficiently than the surrounding tissue, therefore, bringing enhanced imaging contrast between tissues. The main clinical uses of Contrast imaging include detecting and characterizing tumors and enhancing blood flow signals.

Contrast Imaging is an option, and may not be available on your ultrasound system.

Only the ABD and Urology exam presets of C5-1Q and C5-2Q transducers support Contrast Imaging.

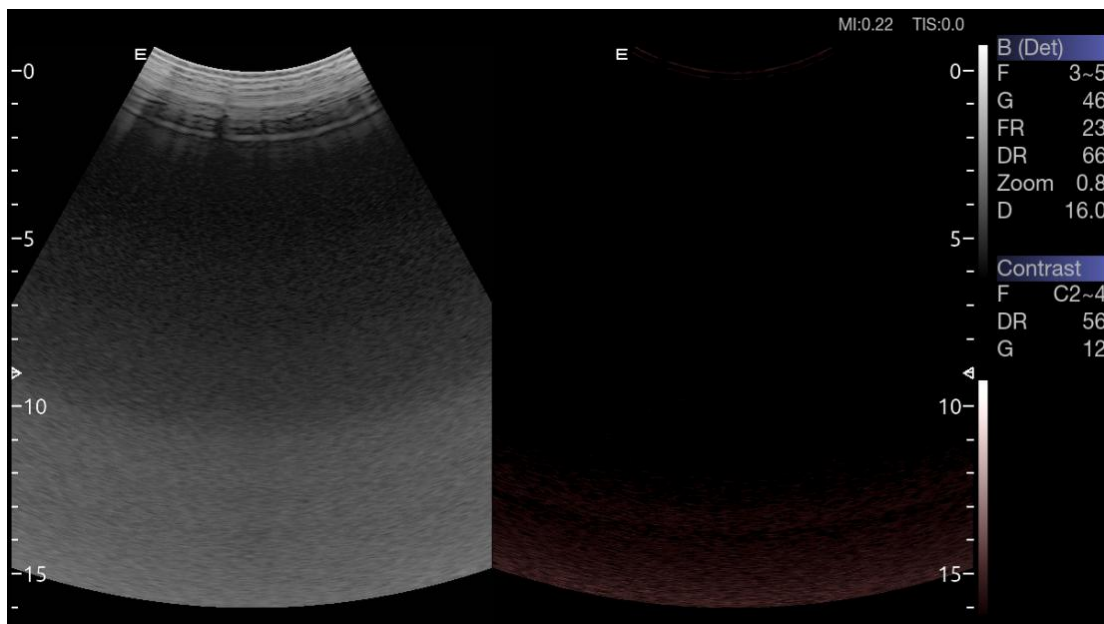


Figure 5-9 Example of Contrast Imaging Display

### **WARNING**


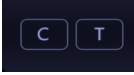
1. Only sonographer, physician or allied health professional who has received appropriate training can use the Contrast Imaging.
2. Only use the contrast agents which were cleared for use by relevant government regulation and approval. EDAN would not guarantee the safety and reliability of any contrast agent.
3. Read, understand and follow the instruction for use accompanied with the contrast agent.
4. Practice ALARA principle when operating ultrasound system. Minimize the acoustic power without compromising the image quality.
5. The application of Contrast Imaging is for reference only. Diagnosis must not be based on results achieved by Contrast Imaging analysis alone.

### **Caution**

1. Because the acting time of contrast agent is short and limited, please make sure the image has been optimized to the possibly best before injecting the contrast agent. Adjusting image parameters during the process of Contrast Imaging will affect the image consistency.


### 5.12.1. Using Contrast Imaging

1. Invoke C5-1Q or C5-2Q transducer as the currently active transducer.
2. Select **ABD** or **Urology** exam preset.
3. Perform the 2D image scanning, and obtain the target image.
4. Press **Contrast** on the touch screen and activate Contrast imaging mode.
5. Adjust the acoustic power or optimize the Contrast image, if necessary, to obtain a good image.

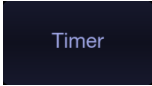
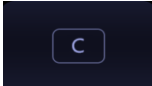

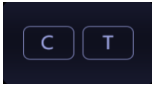
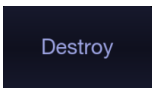

6. Press  or  touch button to enter Tissue and Contrast dual display.


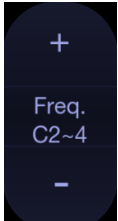

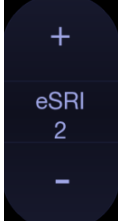
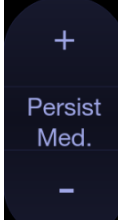
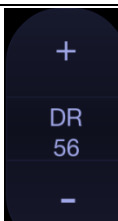
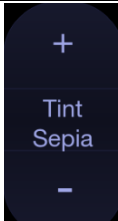
7. Inject contrast agents, and press **Timer** on the touch screen to start timing.  
When the Timer starts, the time will be display on the image.



8. Press the  key to store the cine loop. The thumbnail of the cine loop will appear in the thumbnails area on the right side of the main screen.
9. Press **Timer** on the touch screen again to stop timing.
10. If necessary, press **Destroy** on the touch screen to destroy the residual microbubbles.
11. Exit Contrast imaging.

### 5.12.2. Touch Screen Controls

Name	Control	Description
Timer		The Timer records the time since the injection of contrast agent. You can use the Timer function by activating it at the time of injection and deactivating it at the end of the exam. First press on Timer touch button activates the Timer and second press on it deactivates the Timer. The timer is displayed on the Image. The timer stops when you freeze the image, and a second timer appears above it and continues to record the time. The second timer displays the total time of this exam.
Display formats		Only displays Contrast image.
		Display Tissue image left and Contrast image right.
		Display Contrast image left and Tissue image right.
Destroy		Press to destroy the residual microbubbles according to the destroy power and destroy time you specify. It is a one-shoot control.
Destroy Power		Adjusts the transmit power provided by the transducer for destroying the residual microbubbles.

<p>Destroy Time</p>		<p>Adjusts the time length for destroying the residual microbubbles.</p>
<p>Frequency</p>		<p>Frequency determines the transmit frequency used by Contrast Imaging mode. Upward presses increase the frequency. Downward presses decrease the frequency.</p>
<p>Acoustic Power</p>		<p>Adjusts the acoustic output power of the activated transducer. It is only available in live imaging. Higher acoustic power numbers correspond to increased sensitivity and penetration in the image, but ALARA principle should be followed in actual situations.</p>
<p>eSRI</p>		<p>eSRI is Speckle Reduction Imaging. There are 4 levels: Off, Low, Med and High. High level provides more aggressive speckle reduction.</p>
<p>Persistence</p>		<p>Persistence averages frames together to reduce random noise. There are 4 options: Off, Low, Med., and High. The persistence level corresponds to the number of frames averaged. The frame rate is unchanged; as each new frame is acquired, it is averaged with the preceding frames.</p>
<p>Dynamic Range</p>		<p>The Dynamic Range, or log compression, adjusts how echo intensities are converted to brightness. A high dynamic range will display more shades of gray, while a low dynamic range will display fewer shades of gray and a more contrasty image.</p>
<p>Tint</p>		<p>The Tint control changes the color tint being used on Contrast image.</p>

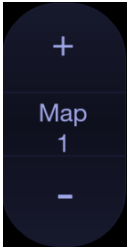
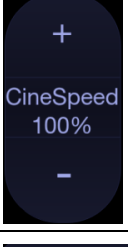
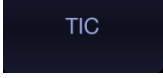
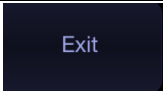
Map		The Gray Map adjusts the post processing map used on the Contrast image. In general, higher map numbers correspond to more contrast in the image.
Cine Speed		Adjusts the speed of playing cine loop.
Time Intensity Curve		Activates Time Intensity Curve displays. See section 5.11.3 for details.
Exit		Exits Contrast Imaging mode.

Table 5-13 Touch Screen Controls of Contrast Imaging

### 5.12.3. Time Intensity Curve (TIC) Analysis

Time Intensity Curve (TIC) quantitatively describes the dynamics of the intravascular ultrasound contrast agent, and thereby provides a quantitative assessment of blood flow perfusion.

#### TIC Analysis Screen Display

An example of TIC analysis screen display is shown as the figure below:

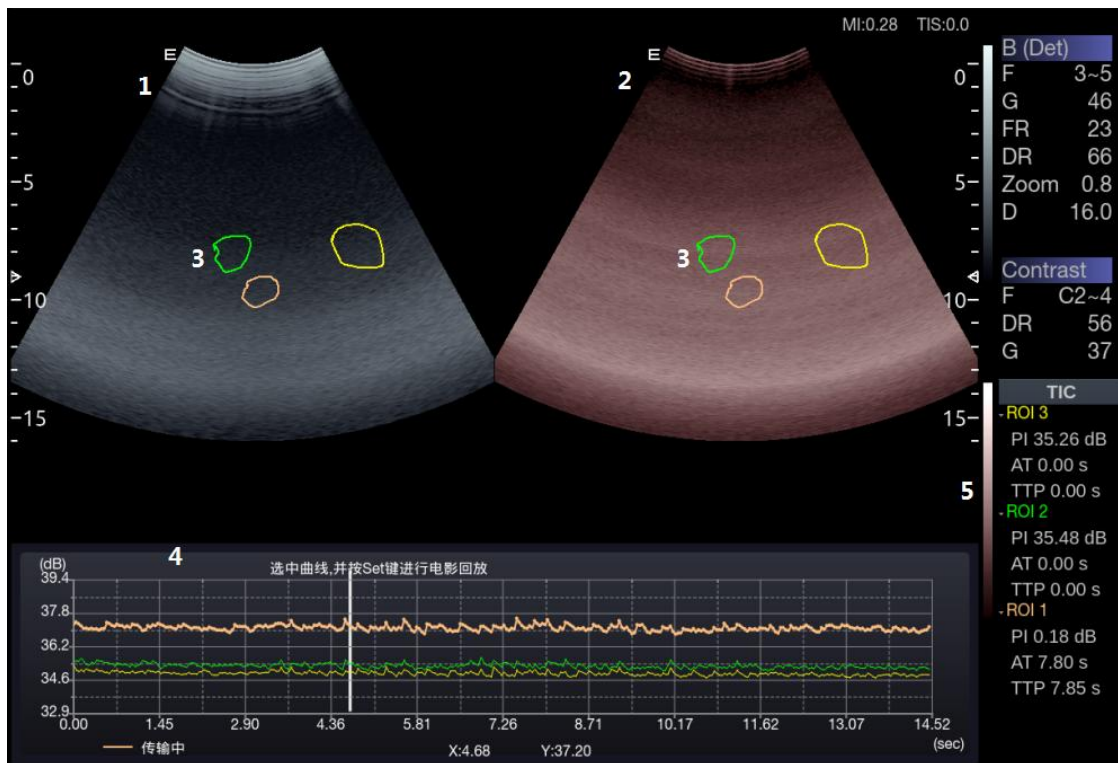
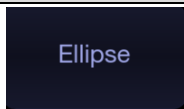
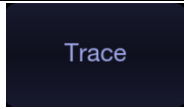
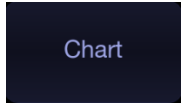
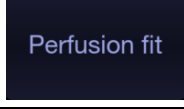
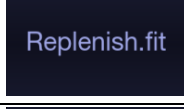
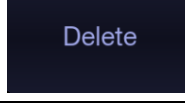


Figure 5-10 Example of TIC Analysis Display

<b>No.</b>	<b>Name</b>	<b>Description</b>
1.	Contrast cineloop window	Displays contrast cineloop and ROIs.
2.	Tissue cineloop window	Displays tissue cineloop and ROIs.
3.	ROIs	The ROI indicates sampling position of the TIC. ROIs are color-coded, and up to 7 ROIs can be displayed.
4.	Analysis window	The TIC Analysis window displays: <ul style="list-style-type: none"> <li>• Y axis represents intensity scale (dB).</li> <li>• X axis represents time (sec).</li> <li>• Time intensity curves, coded with the same color of its sample area.</li> <li>• Frame marker, a white vertical line.</li> <li>• Time at the frame marker position.</li> <li>• Intensity at the frame marker position.</li> <li>• The active curve.</li> </ul>
5.	TIC parameters	Displays TIC parameters of each sample area (ROI). These parameters include: <ul style="list-style-type: none"> <li>• PI (Peak Intensity): contrast peak intensity.</li> <li>• AT (Arrival Time): time point where contrast intensity appears.</li> <li>• TTP (Time to Peak): time point where the contrast intensity reaches peak value.</li> </ul>

The TIC analysis touch screen displays the following controls:

<b>Name</b>	<b>Control</b>	<b>Description</b>
Ellipse tool		Ellipse tool for placing ROIs on contrast image.
Trace tool		Trace tool for placing ROIs on contrast image.
TIC Chart		Show/hide TIC chart. Only available when at least one ROI is placed on the image. The TIC chart is displayed below the image area.
Fit Curving		Press to perform fit curving.
		
Delete		Removes ROIs from the image one by one.

Exit	Exit	Exits TIC Analysis.
------	------	---------------------

### **Basic TIC Analysis procedures**

1. Perform the scanning and inject Contrast agent.
2. Freeze the image or select a range of images for analysis.  
Or, Select a desired cine loop from the stored images.
3. Press **TIC** touch button to activate time intensity curve analysis.
4. Place ROIs (region of interest) on one of these images, and time intensity curves are displayed below the image area.  
Up to 7 ROIs with different colors can be created on the image. Each ROI corresponds to one TIC displayed in the chart below the image area. The colors of ROI and its TIC are consistent. Two tools can be used to place ROIs: Ellipse and Trace. Press **Ellipse** or **Trace** on the touch screen, and follow the instructions displayed on the screen to determine the shape of the ROI.
5. Selecting one TIC for analysis.  
To select one TIC: press the <**Cursor**> key on the control panel, move the cursor onto one TIC, and then press Set key. The currently selected TIC is indicated by "Active" below the TIC chart. When one TIC is selected, rolling the trackball will move the frame marker and can view the intensity and time at the frame marker position. Pressing Set key can play the cineloop.
6. If necessary, perform curve fitting.
7. Analyze of the parameters of the curve.
8. Press <**Freeze**> key or **Exit** key to exit TIC analysis.

## 5.13 ECG

The ultrasound system can be configured with an optional ECG module. The ECG module obtains ECG signals via ECG patient cable to display ECG waveform synchronously with the ultrasound image. The ECG signals can be used as time reference in cardiac exam for marking the systolic and end diastolic moments.

---


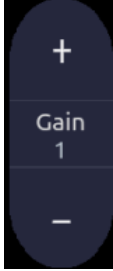

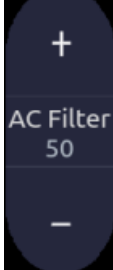
### **WARNING**

---

1. The ECG waveforms displayed on the main screen are not intended for ECG diagnosis and monitoring.
  2. The ECG module and electrodes are not intended for intra-cardiac use or direct cardiac contact.
  3. Do not use the ECG function on the patient with pacemaker.
  4. Only the ECG module, patient cable and electrodes supplied by EDAN can be used.
  5. Only authorized service personnel can service the ECG module.
  6. The conductive parts of electrodes and associated connectors, including the neutral electrode, should not contact any other conductive parts including earth.
  7. The electrodes must be removed from the patient before a high-frequency surgical equipment is used on the patient.
  8. The quality of the ECG waveform depends on the stability and conductivity of the electrodes because patient's movements can cause artifacts.
  9. Only the ECG applied part is defibrillation-proof. Please remove transducer and other accessories from patient before defibrillation. Always refer to the defibrillator's user manual when performing defibrillation.
  10. After defibrillation, the ECG waveform recovers within 10 seconds if the correct electrodes are used and applied according to the manufacturer's instructions.
  11. Always do the follows prior to operation:
    - Check the patient cable for visible evidence of any damage. If any damage is found, a new patient cable should be used.
    - Connect the electrodes to patient correctly following the manufacturer's instruction. If a ECG lead is off, the ultrasound system will display " ECG Lead Off " message..
  12. The disposable electrodes can only be used for one time. Do not use the electrodes passing its expiry date.
  13. The disposable electrodes should be disposed of according to the local regulations.
  14. Regularly check, clean and maintain the patient cable and electrodes following the manufacturer's instruction.
-

### 5.13.1. ECG Touch Screen Controls

The following touchscreen controls impact the ECG function:

Name	Control	Description
ECG		Displays or hides ECG waveforms and heart rate value on the main screen.
Gain		Adjusts the gain of ECG waveform.
ECG Lead		Selects the ECG lead from I, II and III lead as the ECG waveform source.
AC Filter		Selects the AC filter frequency according to the AC power you use. 50 Hz and 60 Hz are available. This could filter the interference from AC power supply.

### 5.13.2. ECG Basic Operations

1. Invoke ECG function.  
Invoke P5-1Q transducer as the currently active transducer. Press **ECG** on the touch screen to invoke the ECG function and display ECG controls on the touch screen.
2. Connect patient cable and electrodes.  
Connect the patient cable to the ECG connector on the ultrasound system first.  
Place electrodes on the patient's body as the figure below (Take 3-lead placement of AHA standard as an example).



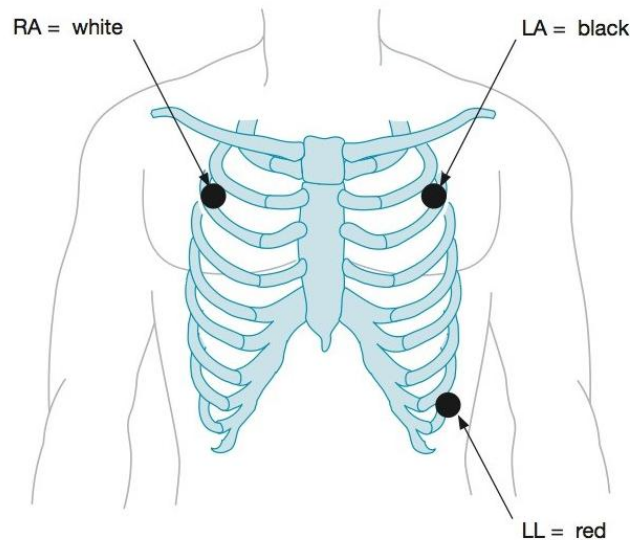


Figure 5-11 3-lead Placement of AHA Standard

3. The image area displays real-time ECG waveform and heart rate value. There is a red mark on the ECG waveform indicating the temporal position of ultrasound image in relation to the ECG waveform.
4. Switch imaging modes and adjust relevant parameters to optimize the image.
5. Adjust ECG Gain and select ECG lead if necessary.
6. Freeze the image and review.
7. Exit ECG mode.

Remove electrodes from patient's body and disconnect ECG module from the ultrasound system.

### **5.13.3. ECG Review**

Pressing <Freeze> key will freeze ultrasound image and ECG waveform at the same time. Moving trackball left or right will playback the ECG waveform and ultrasound image together. The red mark on the ECG waveform indicates the time of the currently displayed image. In this manner, you can move the red mark to locate the diastolic or systolic moments and check relevant ultrasound image at that moment.

## 6 Transducers and Biopsy

### 6.1 Transducer Model

No.	Model	Type	Application	Applied Region
1	L17-7HQ	Linear	Small Parts(Thyroid, Testes, Breast) Peripheral Vascular Musculoskeletal	Body Surface
2	P5-1Q	Phased array	Adult Cardiac Abdominal Pediatric Cardiac Adult Cephalic	Body Surface
3	E8-4Q	Micro Convex	Fetal / Obstetrics Trans-vaginal Trans-rectal Urology Gynecology	Intra-cavity
4	C5-2Q	Convex	Abdominal Fetal / Obstetrics Urology Gynecology Musculoskeletal	Body Surface
5	L12-5Q	Linear	Abdominal Small parts(Thyroid, Testes, Breast) Peripheral Vascular, Musculoskeletal	Body Surface
6	L17-7SQ	Linear	Intra-operative Musculoskeletal Peripheral Vascular	Body Surface/ Intra-operative
7	MC8-4Q	Micro Convex	Pediatric Abdominal Neonatal Cephalic Musculoskeletal Peripheral Vascular	Body Surface
8	MC9-3TQ	Micro Convex	Pediatric Abdominal Neonatal Cephalic Peripheral Vascular Musculoskeletal	Body Surface

9	P7-3Q	Phased Array	Adult Cardiac Pediatric Abdominal Pediatric Cardiac Neonatal Cephalic	Body Surface
10	C7-2XQ	Convex	Abdominal Fetal / Obstetrics Urology Gynecology Musculoskeletal	Body Surface
11	E10-3BQ	Micro Convex	Fetal / Obstetrics Trans-vaginal Trans-rectal Urology Gynecology	Intra-cavity
12	E10-3HQ	Micro Convex	Fetal / Obstetrics Trans-vaginal Trans-rectal Urology Gynecology	Intra-cavity
13	C6-2MQ	Convex	Fetal / Obstetrics Abdominal Gynecology	Body Surface
14	C5-1Q	Convex	Abdominal Fetal / Obstetrics Urology Gynecology Musculoskeletal	Body Surface

Table 6-1 Transducer Model &amp; Application

## 6.2 Using Transducers

### Understanding a Transducer:

Figure 6-1 takes L12-5Q transducer to show an example of a transducer.

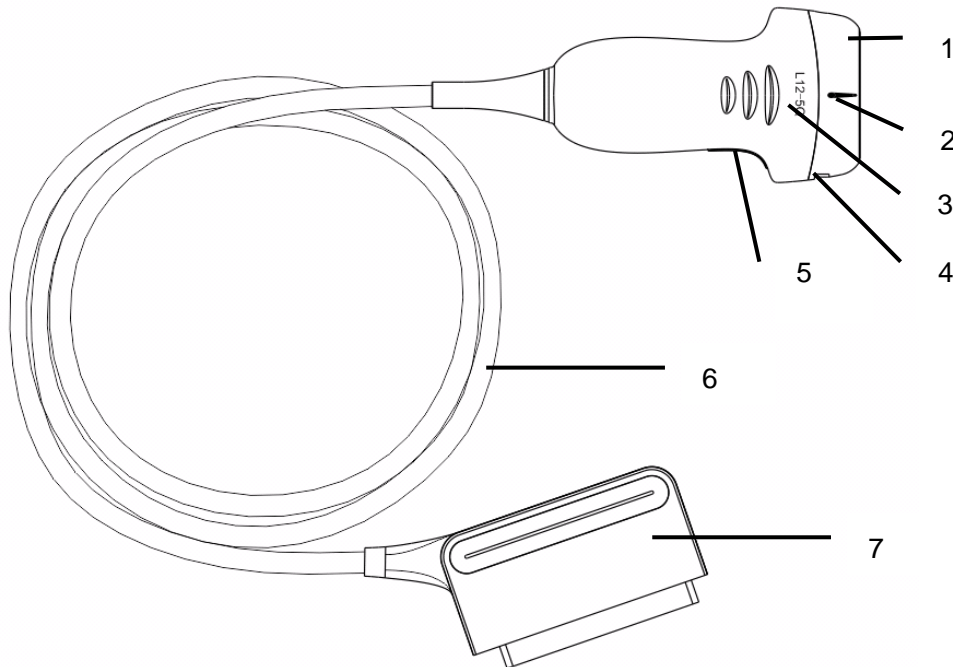


Figure 6-1 Typical transducer

No.	Name	Function
1	Transducer head	Converts electrical signals to sound waves, and then converts received echoes back to electrical signals. The tip of the transducer is the acoustic lens.
2.	Center line mark	Indicates the center line position of the transducer, which are usually used for out-of-plane needle guide.
3.	Transducer model	Displays the transducer model.
4	Needle-guided bracket fixing tabs and groves	Provides mounting support for the needle-guided bracket.
5.	Transducer orientation mark	The side of orientation mark on the transducer corresponds to the side of orientation mark on the display screen
6	Transducer cable	Transmits electrical signals between the transducer head and the transducer connector.
7	Transducer connector	Connects the transducer to the ultrasound imaging system.

### ***Image Orientation Mark***

The image orientation marks on the display screen and on the transducer are shown as below. The side of orientation mark on the transducer corresponds to the side of orientation mark on the display screen. Ensure orientation marks on the display screen and transducer are on the same side prior to scanning.

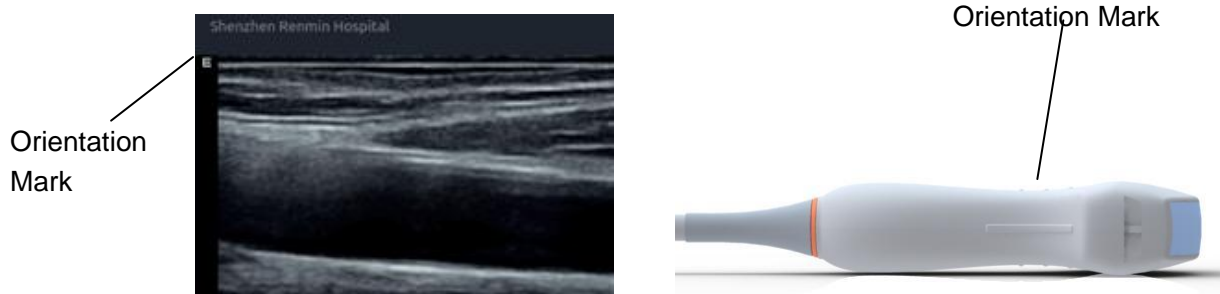


Figure 6-2 Image Orientation Mark

### ***Proper Use of Transducers***

To extend the service life and maintain optimum transducer performance, please operate as follows:

- Inspect transducer cable, socket and acoustical window of the transducer periodically.
- Shut down the machine before connecting or disconnecting the transducer.
- Do not drop the transducer onto the floor or collide with hard objects. Otherwise it will be damaged easily.
- Do not heat the transducer.
- Do not pull or bend the transducer cable.
- Coupling gel can only be used on the head of the transducer, and it should be wiped off after use.
- Clean and disinfect the transducer after every use.
- The acoustical window and the shell of the transducer should be examined frequently.

### **CAUTION**

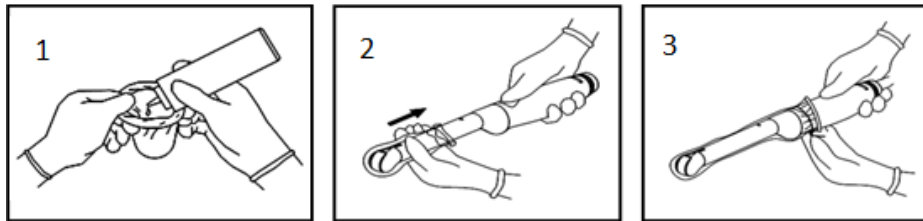
1. Do not disinfect or clean transducers under high temperature. The temperature should be below 45°C.
2. To avoid damaging the device, the disinfection method is limited to regular maintenance of devices in hospitals. Disinfecting instruments should be cleaned first.
3. The coupling gel adapted to the transducer is a medical ultrasound coupling gel. Use only ultrasound coupling gel that complies with local regulations.

## ***Use of Transducer sheath***

### **CAUTION**

1. Always wear gloves to perform the following steps.
2. To minimize disease transmission, legally marketed, sterile transducer sheath is required to use for intra-cavitary and intra-operative procedures.
3. Use a pyrogen-free transducer sheath for intra-operative procedures.
4. DO NOT use an expired transducer sheath. Check whether the term of validity has expired prior to using transducer sheaths.
5. The single-use sheath should comply with the local regulations.
6. Before cleaning or disinfecting the transducer, remove the sheath gently and discard it. Put on a new single-use sheath before using the transducer.
7. Use of protective sheath with natural rubber latex may lead to a severe anaphylactic reaction in persons sensitive to the natural latex protein.
8. Transducer sheath should be used with all clinical situations where infection is a concern.

To install transducer sheath:



1. Place an adequate amount of sterile coupling gel in the protective sheath and/or on the acoustic window of the transducer;
2. Insert the transducer into the sheath;
3. Pull the sheath over the transducer and cable until the sheath is fully extended. Check and eliminate bubbles between the surface of the transducer and the sheath. Be careful not to pierce the sheath.
4. Secure the sheath using the bands or clips supplied with the sheath;
5. Inspect the sheath to ensure that there are no damages (i.e. holes or tears).

## 6.3 Transducer Cleaning and Disinfecting

Transducers should be cleaned and/or disinfected as necessary or between use with a recommended cleanser or disinfectant. Disconnect the transducer from the system prior to cleaning and disinfecting.

### 6.3.1. Cleaning

The validated cleaning agents for cleaning the transducers are:

- Ethanol (75%)
- Isopropanol (70%)

Cleaning agents should be applied and removed using a clean, soft, sterile, non-abrasive cloth or paper towel.

To clean the transducers:

1. Disconnect the transducer from the system.
2. Wear sterile protective gloves to prevent infection.
3. Remove all residual foreign matters from the transducer using sterile cloth or paper towel immediately after examination. For the situation where a protective sheath is used, the protective sheath should be removed first and discarded.
4. Wipe the surface of transducer and cable with a sterile cloth dampened with the cleaning solution until no visible contaminants remain.
5. After cleaning, wipe off the cleaning solution with a new sterile cloth dampened with tap water until no visible cleaning agent remains.
6. Wipe off with a dry sterile cloth to remove residual moisture.
7. Leave the transducer to air dry.
8. If the transducer is not visually clean at the end of the cleaning steps, please repeat the cleaning steps through step 4 to step 7.
9. Inspect the transducer to ensure that there is no damage. The transducer should be disposed of properly when any damage is found.

### **WARNING**

1. Unplug the transducer from the system prior to cleaning or disinfecting.
2. To avoid infection, always use protective gloves when performing cleaning and disinfecting procedures.
3. Prohibit infiltration of any type of liquid into the device or the transducer.

### 6.3.2. Disinfection

Selecting a proper way to disinfect your transducers based on your transducer applied region:

<b><i>Transducer Applied Region</i></b>	<b><i>Transducer Type</i></b>	<b><i>Disinfecting Intensity</i></b>	<b><i>Disinfecting Method</i></b>
Contact intact body surface	Body surface	LLD	Spraying or wiping
Contact mucous membrane	Intra-cavity	HLD	Immersion

Contact normally sterile tissue	Intra-operative	Sterilization	Immersion
Note: LLD=Low-level Disinfection; HLD=High-level disinfection			

The validated disinfectants for transducer are:

<b>Disinfectants</b>	<b>Disinfecting Intensity</b>	<b>Disinfecting Method</b>
Ethanol (75%)	LLD	Spraying or wiping
Isopropanol (70%)	LLD	Spraying or wiping
Cidex OPA (0.55%)	HLD	Immersion
Cidex Glutaraldehyde(2.4%)	HLD, Sterilization	Immersion

### **WARNING**

1. Unplug the transducer from the system prior to cleaning or disinfecting.
2. To avoid infection, always use protective gloves when performing cleaning and disinfecting procedures.
3. To avoid infection, ensure that expiration date of the disinfecting solution has not passed.
4. Please cleaning the transducer prior to disinfection.

#### ***Disinfecting by spraying or wiping:***

1. Disconnect the transducer from the system.
2. Wear protective gloves to prevent infection.
3. Clean and dry the transducer according to the methods in section *6.3.1 Cleaning*.
4. Prepare the disinfectant solution (75% ethanol or 70% isopropanol).
5. Spray the solution to the transducer interface or wipe it with a sterile cloth dampened with the disinfectant solution. Follow the disinfectant manufacturer's recommended contact time and mode.
6. Rinse the transducer according to the disinfectant instructions. Wipe the transducer with a dry sterile cloth or leave the transducer to air dry.
7. Inspect the transducer to ensure that there is no damage.

Note:

If Ethanol or Isopropanol is used for both cleaning and disinfecting, then a new sterile cloth is required for the disinfection step.

#### ***Disinfecting by Immersion:***

1. Disconnect the transducer from the system.
2. Wear protective gloves to prevent infection.
3. Clean and dry the transducer according to the methods in section *6.3.1 Cleaning*.
4. Prepare the disinfectant solution (Cidex OPA 0.55% or Cidex Glutaraldehyde 2.4%). Refer to the



instructions provided by the disinfectant manufacturer for the concentration of the disinfection solution, method of dilution, method of disinfection, temperature and cautions during use.

5. Place the cleaned and dried transducer in contact with the disinfectant (refers to figure 6-3 for the contacting area) for the time specified by the disinfectant manufacturer. For example, the contact time recommended by the manufacturer for soaking in Cidex Glutaraldehyde(2.4%) is at least 45 min.
6. Rinse the transducer thoroughly with sterile water to remove all chemical residues. For example, it is required to flush the transducer after soaking in Cidex Glutaraldehyde(2.4%) with plenty of sterile water (about 2 gallons) at least one time. Or, follow the complete rinsing instructions provided by the disinfectant manufacturer to rinse the transducer.
7. Wipe off the water on the transducer with a dry sterile cloth. Leave the transducer to air dry.
8. Inspect the transducer to ensure that there is no damage.

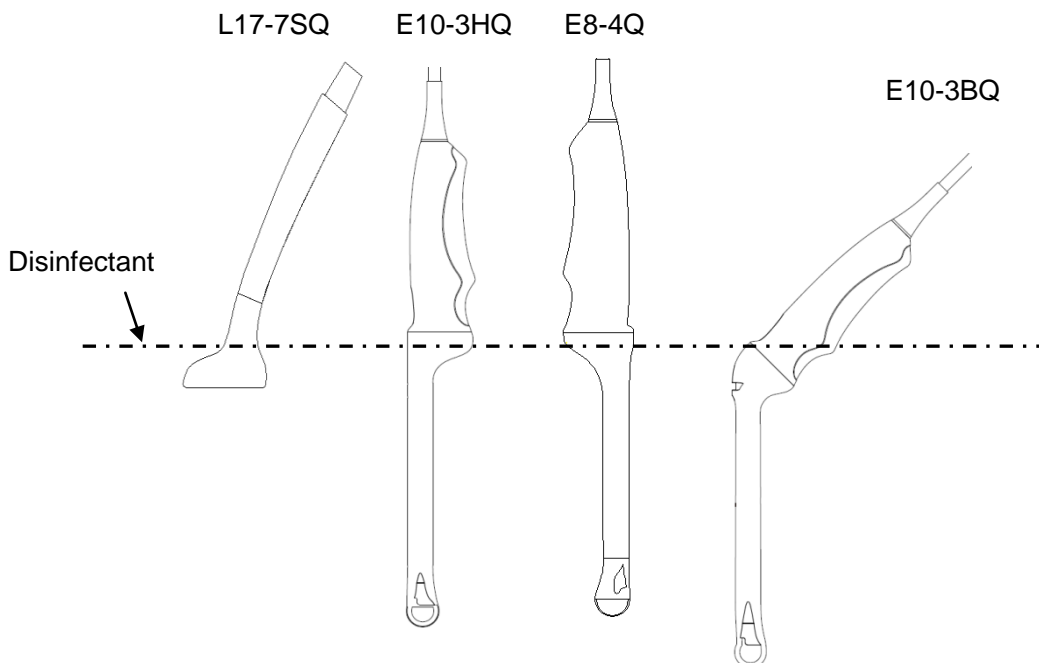


Figure 6-3 Depth of the Transducer Immersed into Disinfectant

---

**WARNING**

1. Do not immerse the transducer connector. If the cable connector is immersed, do not plug the connector into the system. Rinse the connector under running water and dry it thoroughly. If necessary, contact EDAN for service.
  2. Prohibit infiltration of any type of liquid into the device or the transducer.
  3. Do not immerse the cable and connector of the transducer into solutions. Transducers can be submerged to, but not including, the strain relief of the transducer array. Do not immerse or soak any part of a transducer in any cleaning material not listed in the recommended list of disinfectant.
  4. Use the immersion method to disinfect the intra-cavitary and intra-operative transducers.
  5. Only non-immersion method can be used with solution of ethanol or isopropanol. The solution concentration should not exceed the value provided above.
-

6. The immersion time should not exceed the time that is specified by the disinfectant manufacturer.
7. Patient contact area should be immersed into the solution while using the immersion method, but should not exceed the depth shown in figure 6-3.

---

### 6.3.3. Sterilization

Intra-operative transducers must be sterilized after each exam.

Sterilizing the transducers:

1. Disconnect the transducer from the system.
2. Wear protective gloves to prevent infection.
3. Clean and dry the transducer according to the methods in section *6.3.1 Cleaning*.
4. Prepare the disinfectant solution (Cidex Glutaraldehyde 2.4%). Refer to the instructions provided by the disinfectant manufacturer for the concentration of the disinfection solution, method of dilution, method of disinfection, temperature and cautions during use.
5. Place the cleaned and dried transducer in contact with the disinfectant (refers to figure 6-2 for the contacting area) for 10 hours. Or, follow the time specified by the disinfectant manufacturer to soak the transducer.
6. Flush the transducer with plenty of sterile water (about 2 gallons) at least one time. Or, follow the complete rinsing instructions provided by the disinfectant manufacturer to rinse the transducer.
7. Wipe off the water on the transducer with a dry sterile cloth. Leave the transducer to air dry.
8. Inspect the transducer to ensure that there is no damage.

---

#### **WARNING**

1. Do not sterilize the transducer using techniques such as autoclave, ultraviolet, gamma radiation, gas, steam, or heat. Severe damage may result.
2. If L17-7SQ transducer is applied to normally sterile tissue without using a sterile sheath, it must be sterilized. If L17-7SQ transducer is applied to normally sterile tissue using a sterile sheath, it should be sterilized, or disinfected(High-level disinfection).

---

### 6.3.4. Storage

---

#### **WARNING**

1. Dry the transducer after high-level disinfection or sterilization and store it in sterile environment.
  2. Do not use the carrying case for storing the transducer, because the carrying case may become a source of infection.
- 
1. Ensure the transducer is cleaned, disinfected, sterilized and completely dried before storage.
  2. Store the transducer in a sterile environment or in a disposable sterile package.
  3. Store the transducer under the following conditions:
    - a) Atmospheric Temp.: -20°C ~ +55°C
    - b) Relative Humidity: 15%~95% (Non-condensing)
    - c) Atmospheric Pressure: 70kPa ~ 106kPa.

## 6.4 Needle Biopsy Guide

### NOTE:

Use proper sterile technique at all times when performing a biopsy.

Always follow these basic precautions:

---

---

### **WARNING**

1. Disinfect the needle guide kit before the first use and after each subsequent use.
  2. Calibrate the needle guide kit (see section 6.4.3) under any of the following conditions:
    - a) The first time that each bracket/transducer combination is used.
    - b) If the bracket or transducer head is dropped or struck, or has evidence of wear.
    - c) If previous use has shown some drift of the needle from the center of the guidelines.
  3. The displayed needle guide pathway on the EDAN video monitor is intended for reference during biopsy procedures. A variety of factors outside EDAN's control, such as changing tissue density, bending of the needle, off-axis pressure by the person holding the transducer, etc., may cause deflection of a needle outside of the displayed video pathway even when the transducer, needle guide, and the system software are all performing as intended and within manufacturing specification. The specialist performing a biopsy procedure must be aware of potential external factors when performing an invasive procedure.
  4. Do not freeze the system when performing a biopsy.
  5. EDAN needle guides are designed and manufactured to attach firmly to designated transducers and should not require excessive force to assemble or disassemble. Do not use a needle guide that requires excessive force or manipulation to assemble or disassemble.
  6. A single-use sheath should be used on transducer when performing a biopsy.
- 
- 

### 6.4.1. Installing Needle Guide Bracket

---

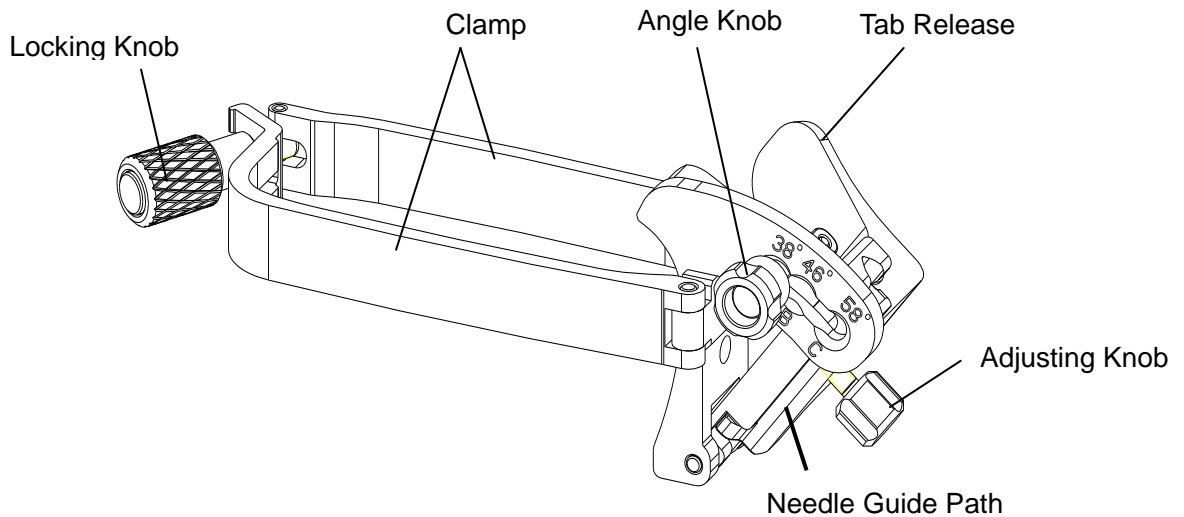
---

### **WARNING**

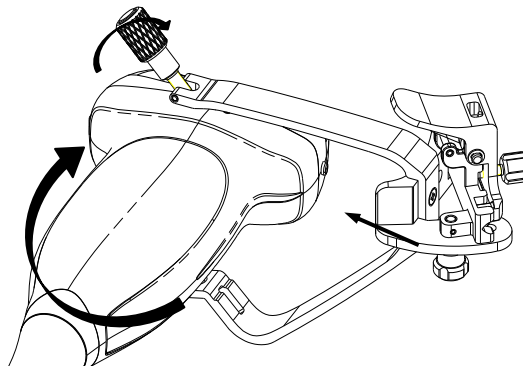
1. For illustration purpose only, transducer and bracket may be shown without a protective sheath. Always place a protective sheath on transducer and bracket to protect cross infection.
- 
- 

#### ■ **BGK-C5-2/BGK-L40UB/ BGK-R15UB/ BGK-004/BGK-007**

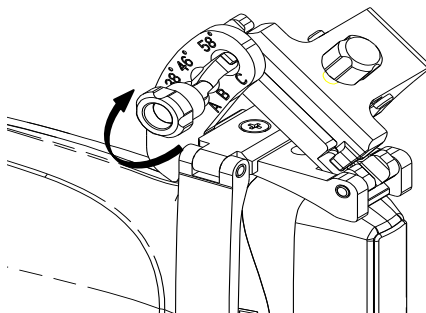
The installation steps for these brackets are the same. Here we take one bracket for illustration.

**Structures:****Installation and Use Steps:**

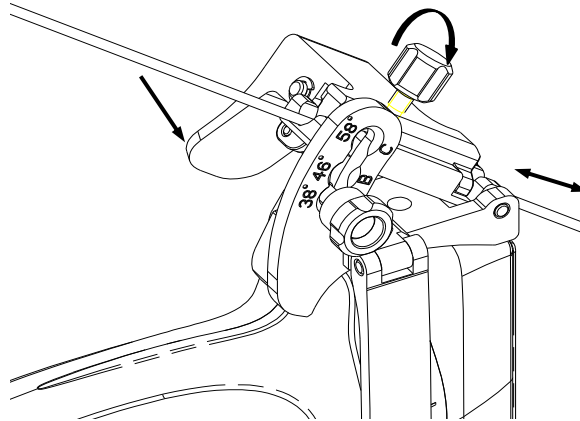
1. Place an appropriate amount of gel on transducer surface, and insert transducer into the sheath.
2. Loosen the locking knob to open the clamp of bracket. Attach the bracket to the transducer by aligning the locating markers on the bracket and the transducer. Properly secure the clamp of bracket with the locking knob. Ensure the bracket is firmly attached.



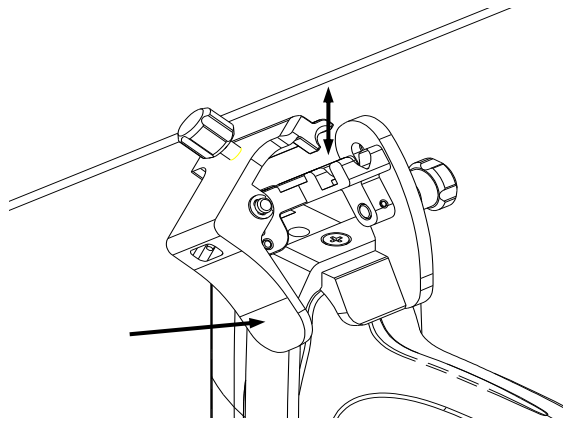
3. Loosen the angle knob to select a needle guide angle, and secure the angle knob.



4. Press the tab release and place the biopsy needle into the needle guide path. Use the adjusting knob to properly secure the needle.

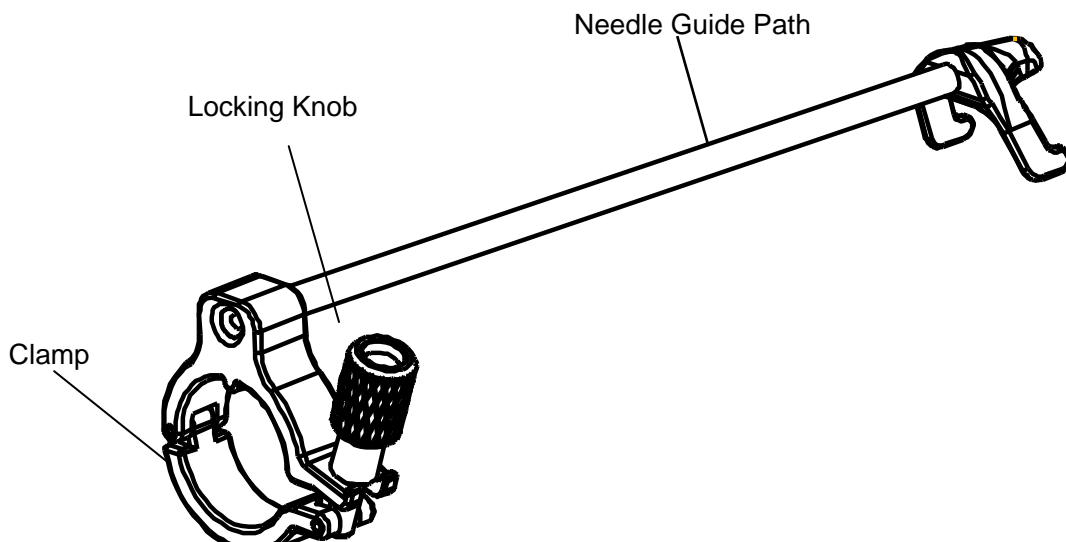


5. After biopsy, press the tab release to remove the needle, and loosen the locking knob to remove the bracket from the transducer.



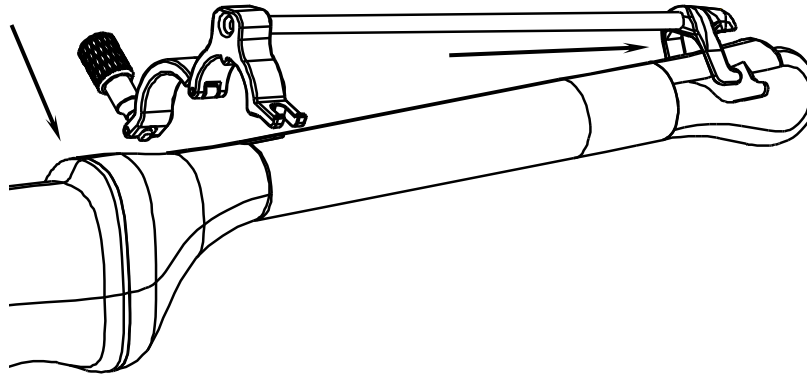
#### ■ **BGK-CR10UA**

##### **Structures:**

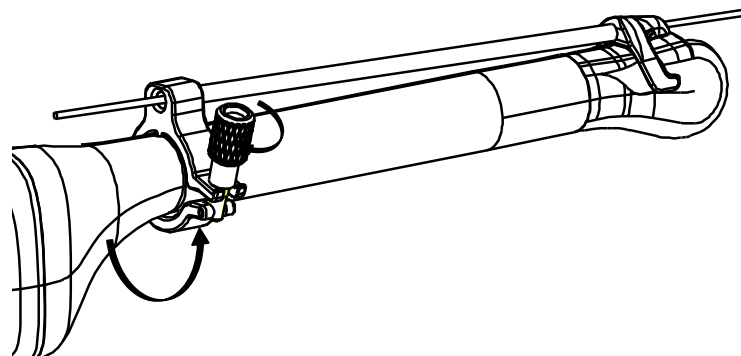


##### **Installation and Use Steps:**

1. Place an appropriate amount of gel on transducer surface, and insert transducer into the sheath.
2. Loosen the locking knob to open the clamp of bracket. Attach the bracket to the transducer by aligning the locating markers on the bracket and the transducer.



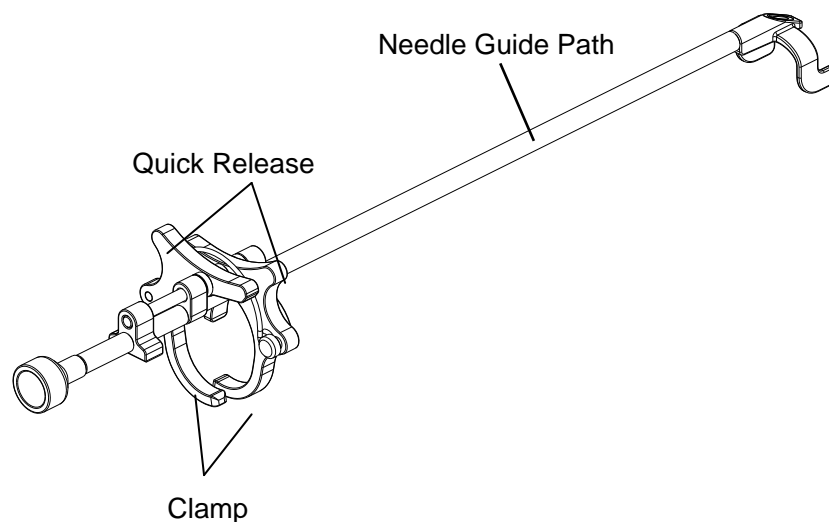
3. Properly secure the clamp of bracket with the locking knob. Ensure the bracket is firmly attached, and then place the biopsy needle into the needle guide path.



#### ■ **BGK-005/BGK-006**

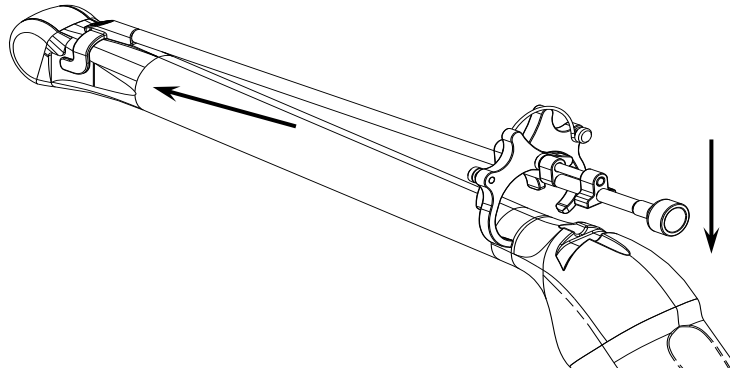
The installation steps for these brackets are the same. Here we take one bracket for illustration.

#### **Structures:**

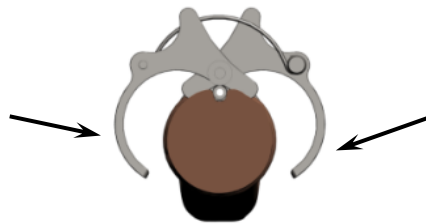


#### **Installation and Use Steps:**

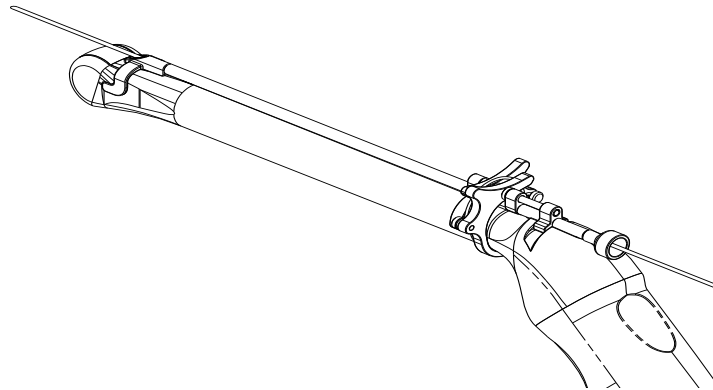
1. Place an appropriate amount of gel on transducer surface, and insert transducer into the sheath.
2. Use the quick release to open the clamp of bracket. Align the locating markers on the bracket and the transducer and push the bracket to click into place.



3. Press the left and right side of the clamp as the figure below to attach the bracket to the transducer firmly.

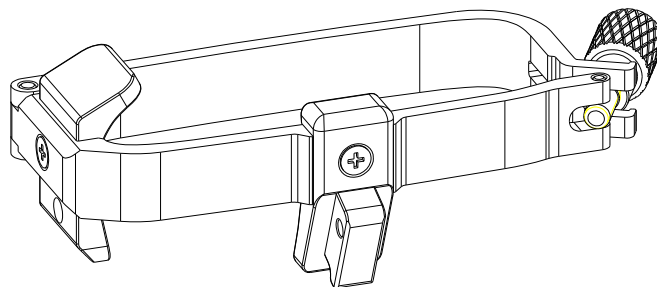


4. Ensure the bracket is firmly attached, and then place the biopsy needle into the needle guide path.



#### ■ **BGK-001**

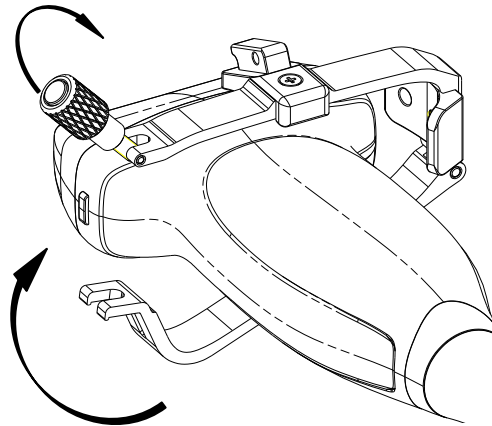
##### **Structures:**



##### **Installation and Use Steps:**

1. Place an appropriate amount of gel on transducer surface, and insert transducer into the sheath.

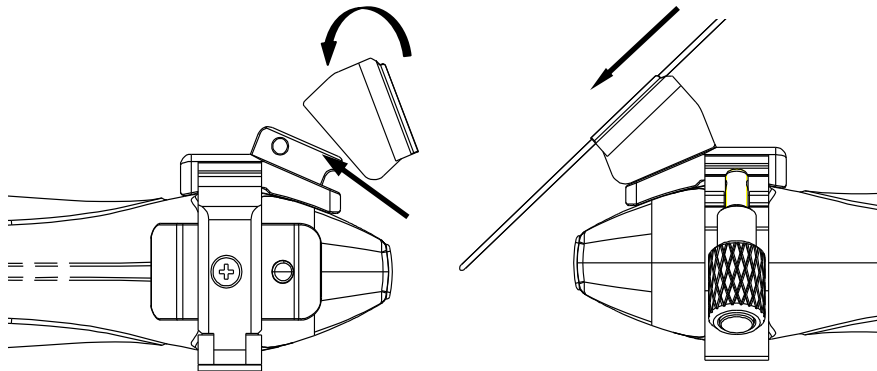
2. Loosen the locking knob to open the clamp bracket. Attach the bracket to the transducer by aligning the locating markers on the bracket and the transducer. Properly secure the clamp of bracket with the locking knob.



3. Install the disposable Needle Guide.
  - a. Select appropriate disposable needle guide to achieve target depth from skin line:

Specification	Depth
21G (1.0cm)	0.8 - 1.2 cm
21G (1.5cm)	1.3 - 1.7 cm
21G (2.0cm)	1.8 - 2.2 cm

- b. Install the needle guide to the needle guide holder, and then put in the biopsy needle:





### 6.4.2. Activating Needle Guide Function

To enable the needle guide function:

1. In the B mode imaging, press **Needle** button on touch screen, A needle touch screen UI is displayed, Press **Enable** button to active the Needle Guide function.
2. Press **Double Line** button to switch double line and single line as the Needle guide Line graphics.
3. Some needle guide brackets support multiple angles. If the current transducer supports such a guide then the **Line** paddle key appears. Pressing it selects guide lines of different angles. Each line represents a corresponding angle marked on the needle guide bracket.

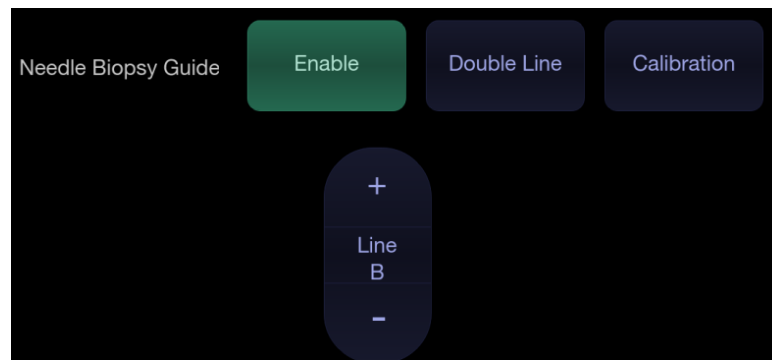


Figure 6-4 Needle Guide Touch Screen

#### **WARNING**

1. To avoid patient injury when using a multi-angle bracket, make sure that the same angle(A, B, C or D) is selected on both the bracket and the ultrasound system.

#### **NOTE:**

The distance between each dot of the needle guide line indicates 0.5 cm.

### 6.4.3. To Adjust the Needle Guide Line

#### **WARNING**

1. Calibrate the needle guide under any of the following conditions:
  - a) The first time a needle guide is used with a given transducer.
  - b) Any time the needle guide or transducer has been dropped or struck against a hard surface.
  - c) After repeated use.
2. Do not use the needle guide bracket if the needle does not track with the guide during calibration.



Figure 6-5 Needle Guide Calibration Touch Screen

**To calibrate the guide line**

1. Assemble the needle guide bracket on the transducer, and use the transducer to image a water bath or needle guide phantom.
2. From the Needle function on the B-mode touch screen, press the **Line** paddle key to select a guide line.
3. Press the **Calibration** button on the touch screen to display the **Angle** and **Position** paddle button.
  - Use the **Position** paddle to adjust the line horizontally until the origin aligns with the actual needle.
  - Use the **Angle** paddle or Angle knob to adjust the angle of the line until the entire line aligns with the actual needle.
4. Any changes will be saved as the default value automatically.

**6.5 Needle Visualization**

**Needle Visualization** is an image processing technology that enhances needle visibility. It is available in B-mode for all linear transducers.



Figure 6-6 Needle Enhancement Visualization

**Needle Visualization** is invoked by pressing the **Needle** button on B-mode touch screen, and then the **Enable** button in the Needle Visualization section of the Needle touch screen. The following parameters can be adjusted when it is active.

- **Enable:** Enables or disables Needle Visualization.
- **L/R:** press to display the angle line on left side or right side of the image field.
- **Shallow/Medium/Steep:** press to enhance the needle visibility for different needle inserted angles: 16° (**Shallow**), 24° (**Medium**) and 40° (**Steep**). For best results use the angle line that is closest to perpendicular to the needle path.

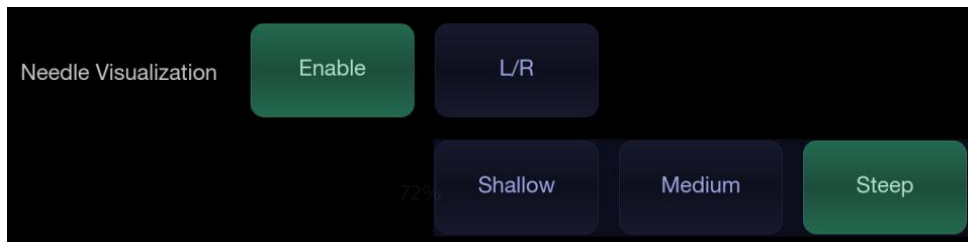


Figure 6-7 Touch Screen for Needle Enhancement Visualization

## 6.6 Center Line

The Center Line is a vertical dotted line displayed at the middle of the image field, representing the middle of ultrasound beam. The Center Line helps to locate the position and depth of a target disease focus for out-of-plane biopsy, lithotripsy and etc..

To use Center Line:

1. Press **Center-Line** on B-mode touch screen to activate Center Line.
2. A dotted center line is displayed vertically at the middle of the image field. The position and direction of the center line cannot be changed.
3. Move the transducer to locate the target.
4. Use distance measurement to obtain the depth of the target.

Note:

Center Line is not available on Intro-cavity transducers.

## 6.7 Needle Guide Bracket Cleaning and Sterilization

### NOTE:

1. Use proper sterilization technique at all times when performing a biopsy.
2. Ensure that protective gloves are worn.

### **WARNING**

1. The needle guide bracket kits are not disinfected or sterilized before delivery. The operators must clean and sterilize the needle guide bracket kits before and after each use.
2. Inspect the bracket for damage such as cracks or breakage. If damage is evident, discontinue use of bracket and contact your Edan representative for disposal guidance.
3. Sterilize the bracket before disposal or sending back to manufacturer for repair.

### **6.7.1. Cleaning**

1. Wear sterile protective gloves to prevent infection.
2. Disconnect the needle guide bracket from the transducer after each use, and remove all visible residues from the needle guide bracket using a small and soft-bristled brush or other similar devices. Do the cleaning quickly before the needle guide bracket dries out.
3. Soak the needle guide bracket in the cleaning solution (Ethanol 75% or Isopropanol 70%) for at least five minutes. Use a soft-bristled brush to clean the needle guide bracket during the soaking.
4. Take out the needle guide bracket from the cleanser and wipe all residues with a sterile cloth.
5. Let the bracket air dry, or dry the bracket with a sterile cloth.
6. If the bracket is not visually clean at the end of the cleaning steps, please repeat the cleaning steps through step 3 to step 5.
7. Inspect the bracket to ensure that there is no damage. The bracket should be disposed of properly when any damage is found.

### **6.7.2. Sterilization**

1. Wear sterile protective gloves to prevent infection.
2. Disconnect the bracket from the transducer, and remove all visible residues from the bracket using sterile cloth.
3. Clean and dry the bracket according to the methods in section *6.7.1 Cleaning*.
4. Sterilize the bracket assembly by dynamic air removal steam sterilizer for at least four minutes at 132°C. Dry the bracket for at least 30 min after sterilization.
5. Inspect the bracket to ensure that there is no damage.

### **6.7.3. Storage**

---

**WARNING**

---

1. Dry the bracket after sterilization and store it in sterile environment.
  2. Do not use the carrying case for storing the bracket, because the carrying case may become a source of infection.
- 
1. Ensure the bracket is cleaned, sterilized and completely dried before storage.
  2. Store the bracket in a sterile environment or in a disposable sterile package.
  3. Store the bracket under the following conditions:
    - a) Atmospheric Temp.: -20°C ~ +55°C
    - b) Relative Humidity: 15%~95% (Non-condensing)
    - c) Atmospheric Pressure: 70kPa ~ 106kPa.

# 7 Features

## 7.1 Comments

The Comments function allows you add annotation to an image. The Comment function is invoked by pressing the <**Comment**> hard key on the console. Figure 7-1 shows an example touch screen for the Comment function. The top portion of the screen shows comments that are pre-defined in pre-sets. See section 10 for details on how to configure these. The bottom portion of the screen shows controls available while the Comment function is active. Table 7-1 gives an overview of these controls.

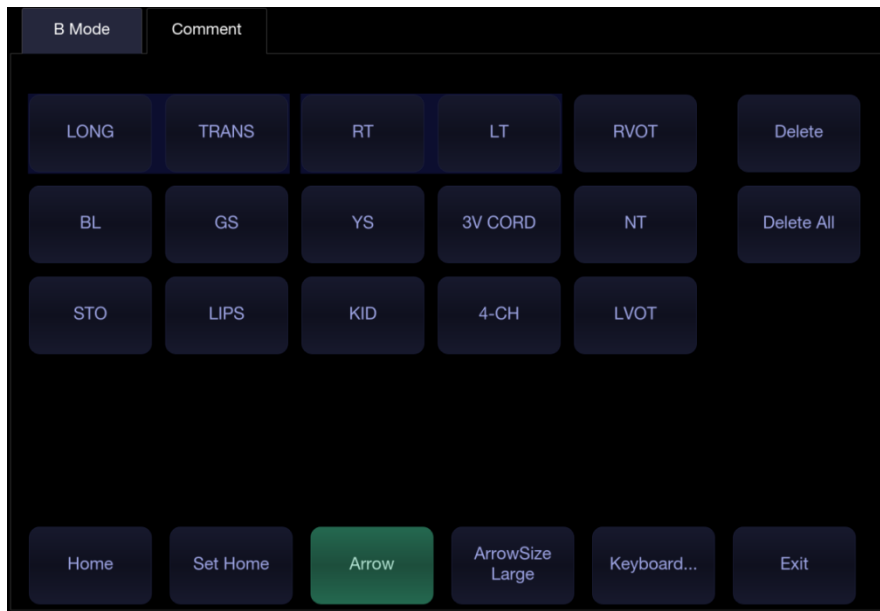


Figure 7-1 Comment Touch Screen

<b>Button</b>	<b>Description</b>
Home	Set the cursor in a pre-defined location.
Set Home	Set the current cursor location as the new Home location
Delete	Delete a whole text or text group or an arrow
Delete All	Clear all comments on the image area
Arrow	Create a new arrow for annotating
ArrowSize	Adjust the arrow size among Large, Mid and Small.
Keyboard	Toggle between showing pre-defined comments(comment library) or a touch screen keyboard. System will remember the last Keyboard status.
Exit	Press to exit the comments function.

Table 7-1 Comment Touch Screen Description

### **Adding comments**

You can add either pre-defined comments or use a keyboard.

#### ➤ **Adding comments using the keyboard**

1. Invoke the Comment function.
2. Use the keyboard of the system or press the "**Keyboard...**" touch screen key to display a keyboard on the touch screen.
3. Move the cursor to the desired location and type the desired text.

#### ➤ **Adding comments using pre-defined comments**

1. Invoke the Comment function
2. Move the cursor to the desired location and press the desired pre-defined comment.

Some of the pre-defined comments may be grouped together with a border surrounding them (such as 'Rt' and 'Lt' in figure 7-1). These are special keys that let you quickly replace one term with another, regardless of where the cursor is within a block of text. For example, if you had entered "Rt. Kidney" as a block of text, pressing the "Lt." button would change that block to "Lt. Kidney" even if the cursor is not at the specific location.

#### ➤ **Adding arrows**

1. Invoke the Comment function
2. Press **Arrow** button on the touch screen, or press <**Cursor**> button on the console to display an arrow at the current cursor location.
3. Press the **ArrowSize** button to adjust the arrow size if necessary.
4. Move the arrow to the desired location. Note that while the arrow is being moved the orientation of the arrow is fixed.
5. Rotate the <**Angle**> knob on the console to adjust the orientation of the arrow.
6. Press <**Set**> key to confirm the arrow and you can now enter text at the end of the arrow.

If the "**Single arrow in comment**" is unchecked in General Setup page, press on <**Set**> key will confirm the arrow and display a second arrow. Repetition of this will add multiple arrows.

### **Modifying comments**

1. Move the cursor to a desired comment, notice that an insert cursor appears in the text as the cursor moves over an existing block of text.
2. Enter text using either the keyboard or pre-defined comments. The new comments will be added to the old text.

### **Deleting comments**

There are several ways to delete comments:

- ◆ Move the cursor to the desired block of comments and press the **Delete** button on the touch screen to delete that block of comments.
- ◆ Press the **Delete All** button on the touch screen to remove all comments.
- ◆ Press the <**Clear**> hard key on the console to remove all comments, body marks, and measurements.

## 7.2 Body Mark

Body Mark allows you add a body mark graphic to an image and indicate the location of the transducer using a transducer icon on that graphic. The Body Mark function is invoked by pressing the **<Body Mark>** hard key on the console. Figure 7-2 shows an example touch screen for Body Mark. The main portion of the screen shows a grid of body marks that are pre-defined in pre-sets. See section 10 for details on how to configure these. The bottom portion of the screen shows controls available while the Body Mark function is active. Table 7-2 gives an overview of these controls.

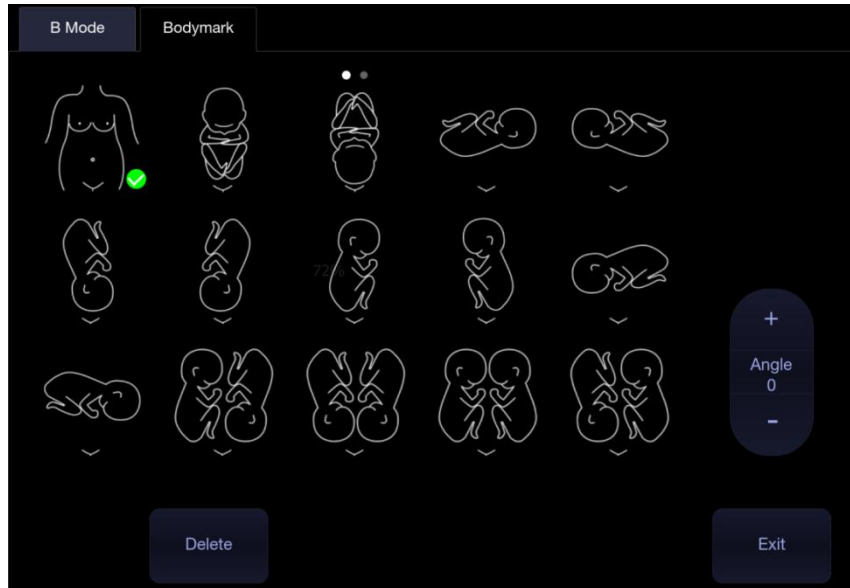


Figure 7-2 Body Mark Touch Screen

<b>Button</b>	<b>Description</b>
Delete	Delete the graphics on the image area
Angle	Rotates the transducer icon on the body mark graphic.
Exit	Press to exit the body mark function.

Table 7-2 Body Mark Touch Screen Description

### Adding a body mark:

1. Invoke the Body Mark function  
The default body mark graphic appears on the main screen, with the transducer icon shown in the default position.
2. Select a desired body mark graphic on the touch screen, that graphic replaces the default.
3. Move the position of transducer icon as needed. The orientation of the transducer icon can be changed with the **Angle** touch screen key or **<Angle>** knob on the console.
4. Press **<Update>** key and roll the trackball to move the position of body mark graphic.  
The **<Update>** key can be used to toggle between moving the transducer icon and moving the body mark graphic
5. Press **<Set>** to complete the adding of a body mark.

**NOTE:**

In dual image or quad imaging mode, body mark can be added separately on each image.

**Deleting a body mark:**

There are two ways of deleting a body mark graphic:

- ◆ Press **Delete** on the touch screen to delete the graphics on the image area.
- ◆ Press the <**Clear**> hard key to delete all body marks, comments, and measurements.

## 7.3 Split Display


### 7.3.1. Dual Imaging

Dual Imaging displays images side by side on the screen. During real-time imaging when Dual imaging is enabled, the active image is displayed in real-time and the other image is frozen.

Dual image display is invoked by pressing **Dual** button on the B-mode touch screen or dual hard key



on the console. Each single press of Dual function during real-time imaging activates the image on one side and the image on other side becomes frozen. With both images frozen, each single press of Dual function toggles between two images, but does not change the frozen status of the system.

In Dual mode, press **Single** button on the touch screen or single hard key  on the console to display the currently active side of image as a single image.

**Dual Exit**

Dual is exited by any of the following:

- Pressing the Quad button or Quad hard key.
- Pressing the B, M, PW, CW hard key.
- Pressing the 3D, 4D button.
- Transducer change, preset recall, or new exam.

Color Doppler is available during dual imaging.

### 7.3.2. Quad Imaging

Quad Imaging displays images in four quadrants on the screen. During real-time imaging when Quad imaging is enabled, the active image is displayed in real-time and other images are frozen.

Quad imaging is invoked by pressing **Quad** button on the B-mode touch screen or quad hard key



on the console. Quad function button is a one-shot button. Each single press on it during real-time imaging activates one of the four images in the following order: from top left image to top right image, then to bottom left image and bottom right image. Each single press on it during frozen status switches among the four images in an order described above. but does not change the frozen status of the system.

**Quad Exit**

Quad is exited by any of the following:

- Pressing the B, M, PW, CW hard key.
- Pressing the Dual button or dual hard key.
- Pressing the 3D, 4D button.
- Transducer change, preset recall, or new exam.

Color Doppler is available during Quad imaging.



## 7.4 Zoom

The system supports two types of zoom:

Pan Zoom: enlarges a full image and pans the enlarged image to view the desired area.

Spot Zoom: focuses on processing the image of the selected area and enlarges the image with higher resolution.

### 7.4.1. Pan Zoom

Pan Zoom is available on the live or frozen image in B mode and Color mode. Rotate the physical



<Zoom> knob on console to zoom an image.

- Zoom Knob
  - Turn the Zoom knob rightwards to make the image bigger.
  - Turn the Zoom knob leftwards to make the image smaller, down to normal size.

When in Pan Zoom mode, use the trackball to pan the position of zoomed image, and the left bottom corner of the display screen displays a live thumbnail of the full image with a green box on it indicating the currently zoomed area.

The B image remains zoomed after entering other imaging modes.

### 7.4.2. Spot Zoom

Spot Zoom is only available on the live image in B mode and Color mode. To use Spot Zoom:

1. Press the <Zoom> knob, and a zoom box is displayed on the image.
2. Use trackball to adjust the position and size of the zoom box. Press <Set> key to toggle between moving the zoom box and adjusting the size.
3. Press the <Zoom> knob again to activate the Spot Zoom mode. The image in the zoom box is enlarged and also the left bottom corner of the display screen displays a thumbnail of the full image with a green zoom box on it indicating the currently zoomed area.
4. If needed, use the trackball and <Set> key to adjust the position and size of the zoom box on the thumbnail and view the enlarged image of other selected areas.
5. Turn the <Zoom> knob rightwards or leftwards to adjust the zoom factor which will be displayed in real time in the parameter area.
6. Press the <Zoom> knob again to exit Spot Zoom.

The B image remains zoomed after entering other imaging modes

Note:

1. In Spot Zoom mode, the thumbnail image is not updated. It is the last image before Spot Zoom mode was activated.
2. In Color mode, the Spot Zoom mode is activated when you first press the Zoom knob, and the position of the zoom box is the same as the Color ROI box, but 10% bigger in size. When the box size or box position is changed, the Color box and zoom box are adjusted so that above relation remains constant.
3. The thumbnail image is only displayed in B mode and Color mode.

## 8 Measurements and Reports

The Measurement function lets you perform measurements on a live or frozen image. The Generic Measurement function is invoked by pressing the <Caliper> hard key on the console, and the Application Measurement function is invoked by pressing the <Measure> hard key on the console.

**Generic Measurements:** These are simple tools like Distance or Area. There is no specific anatomy associated with these measurements and they do not appear in a report.

**Application Measurements:** These are measurements for specific anatomy or clinical conditions. The results can be entered into a report that can be printed later.

### Understanding Measurement Main Screen Display

The following figure is an example of the measurements displayed on the left side of main screen. The measurements displayed on main screen varies with different imaging modes and exam presets. Here we take the measurements main screen display of B-mode Carotid preset for illustration:

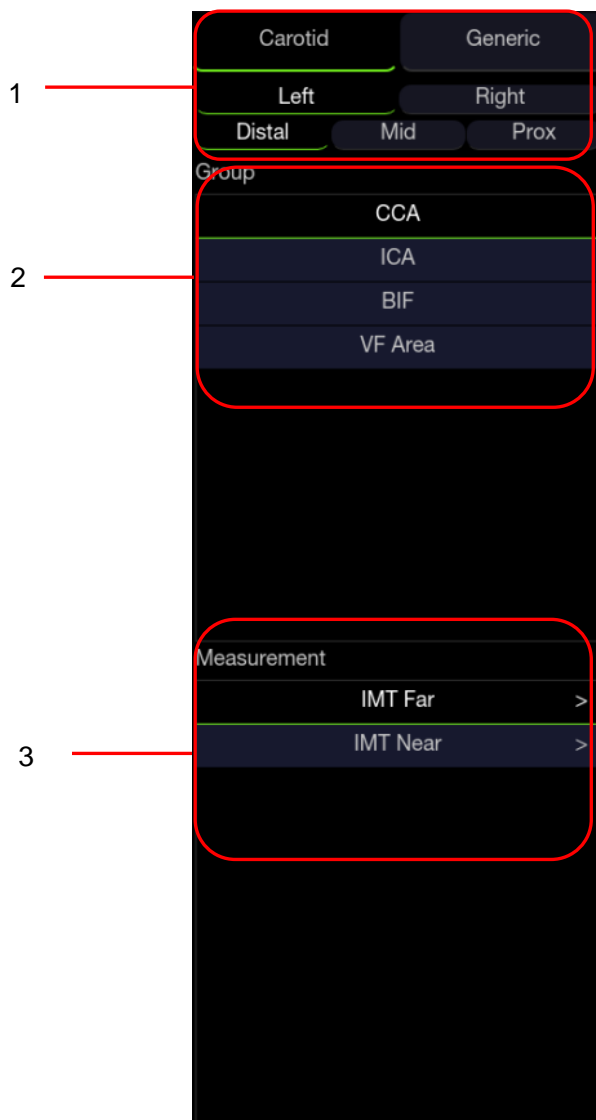


Figure 8-1 Measurement Main Screen Display

Measurement main screen display is divided into three fields:

Field 1: Displays measurement labels and attributes:

- The first line displays labels of Application Measurements and Generic Measurements. Clicking on each of them displays its associated measurement items.
- The second and third line display the attributes of Application measurement: Left, Right, Proximal, Mid, Distal, Fetus A, Fetus B, Fetus C, Fetus D, etc. For example, in Carotid exams, IMT measurements can be done for right or left carotid; in Abdomen exams, measurements can be done for right or left kidney; in Vascular exams several measurements can be done in a Proximal, Mid, or Distal location; in a twin OB exam the OB measurements can be done on either fetus.

Field 2: Displays measurement groups.

All the measurement items supported by this ultrasound system are categorized into different groups based on clinic applications, which facilitates locating the desired measurement item on the main screen and touch screen. The measurement groups vary with the current active application measurement package or generic measurements. The measurement groups included in each application measurement package are configurable in Measure Setup (See section 10.4). Selecting one measurement group will show its associated measurement items below in Field 3.

Field 3: Displays measurement items.

This field displays all currently available measurement items of the selected measurement group. The measurement items included in each measurement group are configurable in Measure Setup (See section 10.4). Select one measurement item, and then measuring operations are allowed on the ultrasound image.

**Understanding Measurement Touch Screen Display**

The following figure is an example of the measurement touch screen display. Here we take the application measurement touch screen display of B-mode Carotid preset for illustration. All the measurements displayed on the touch screen and main screen are consistent.

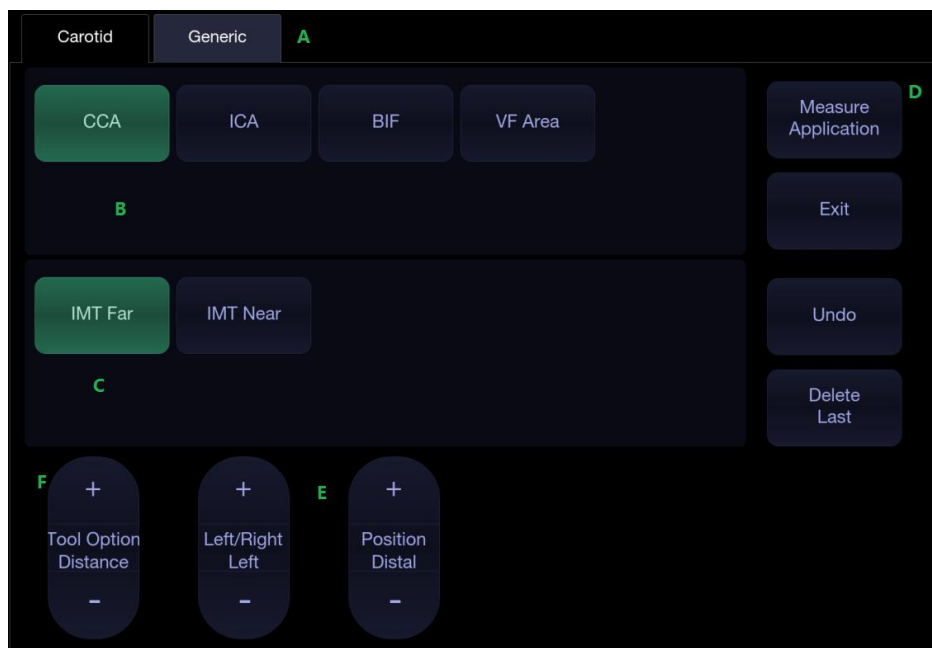


Figure 8-2 Application Measurement Touch Screen Display

<b>No.</b>	<b>Name</b>	<b>Description</b>	
A	Measurement label	Displays application and generic measurement labels. Pressing on any label will display its associated measurements on the touch screen.	
B	Measurement groups	Displays available measurement groups. Selecting one measurement group will show its associated measurement items below.	
C	Measurement items	Displays all available measurement items of the selected measurement group. Select one measurement item, and then measuring operations are allowed on the ultrasound image.	
D	Controls	Application Measurement	When you want to perform one measurement which is not included in current application measurement package, pressing this button will bring you all the application measurements supported on this system, and then select the desired measurement.
		Exit	Exit measurement function.
		Undo	Undo the last operation.
		Delete Last	Delete the last measurement result.
E	Measurement attributes	Displays the attributes of some application measurements, such as Left, Right, Proximal, Mid, Distal, Fetus A, Fetus B, Fetus C, Fetus D, etc. Switch these attributes by the paddle keys. These attributes are only displayed when they are applicable.	
F	Tool Options	When one measurement supports different tools, one Tool Option paddle key will display for switching tools.	

### Understanding Measurement Result Window


The measurement result window is displayed at the upper left corner of the image area by default. The following figure is an example of measurement result window.



Figure 8-3 Measurement Result Window

In the measurement result window, the following operations are allowed.

1. Show/Hide measurement result window.

Clicking on the Cross symbol  (indicated by "1" in the figure above) will show or hide the measurement result window.

2. Move measurement result window.

Move the cursor over the top of the measurement result window (indicated by "2" in the figure above), press **<Set>** key and then move the measurement result window to the desired position.

3. Edit measurement results.

Move the cursor to one measurement result, press **<Set>** key, and a menu displays allowing the following operations:

**Delete:** Deletes the measurement result as well as its measurement lines in the image area.

**Restart:** Invokes the measurement lines in the image area and redo the measurement.

**Cancel:** Closes the menu.

## 8.1 Generic Measurements

Generic measurements is invoked by pressing <**Caliper**> key on the control panel. Each imaging mode supports different types of generic measurements. This chapter describes all the generic measurements supported in each imaging mode.

### 8.1.1. B-mode Generic Measurements

The generic measurements supported in B-mode are listed in the table below.

No.	Measurement Group	Measurement Item	Remark
1.	Distance	Dist. 2 Point	
		Stenosis% Dist.	
2.	Circ/Area	Area Ellipse	
		Area Trace	
		Area Spline	
		Stenosis% Trace	
		Stenosis% Ellipse	
3.	Angle	Angle 3 Point	
4.	Volume	Volume 3 Dist.	
		Ellipse 1 Dist.	
5.	Vessel	Vessel Diam.	2-point distance method
		Vessel Area	Ellipse method
		Stenosis% Diam.	
		Stenosis% Area	
		IMT	2-point distance method
		VF Area	2-point distance method
6.	Elastography	Eratio-Area	Only available for Elastography mode.
		Eratio-Trace	

#### 8.1.1.1. Distance

The distance measurement measures the distance between two points.

##### 2-Point Method:

1. Invoke the generic measurement function.
2. Select **Distance**-> **Dist. 2 Point**.
3. Move the caliper to the start point.
4. Press the <**Set**> key to fix the start point.
5. Move the caliper to the end point.

Presses of the <**Update**> key will toggle between active calipers, allowing you to adjust the position of start point and end point.

6. Press the <**Set**> key to fix the end point and complete the measurement.

### 8.1.1.2. Circumference/Area:

Circumference/Area measurement can measure the circumference and area of a closed region. There are Ellipse, Trace and Spline methods.

#### **Ellipse Method:**

1. Invoke the generic measurement function.
2. Select **Circ/Area-> Area Ellipse**.
3. Move the caliper to the start point.
4. Press the **<Set>** key to fix the start point.
5. Move the caliper and press the **<Set>** key to fix the end point. An ellipse appears and can be adjusted with the trackball.

Presses of the **<Update>** key will toggle between active calipers, allowing you to adjust the ellipse diameter.

6. Press the **<Set>** key to complete the measurement.

#### **Trace Method:**

1. Invoke the generic measurement function.
2. Select **Circ/Area-> Area Trace**.
3. Move the caliper to the start point.
4. Press the **<Set>** key to fix the start point and start drawing the trace.
5. Moving the caliper to mark the trace outline.
6. Press the **<Set>** key to complete the trace.

#### **Spline Method:**

1. Invoke the generic measurement function.
2. Select **Circ/Area-> Area Spline**.
3. Move the caliper to the desired location.
4. Press the **<Set>** key to place the first point.
5. Repeat step 3~4 to place other points. A closed trace will be created after three points are placed.
6. If a point is not placed satisfactorily, press **Undo** button to remove it. Each press of **Undo** button removes one point.
7. Double press the **<Set>** key to complete the trace.

### 8.1.1.3. Angle

The Angle measurement is always done with an angle tool. To measure Angle:

1. Invoke the generic measurement function.
2. Select **Angle-> 3 Point**.
3. Move the caliper to the vertex of the angle you are measuring, and press the **<Set>** key to fix the first point.
4. Move the caliper to one end of the angle, and press the **<Set>** key to fix the second point.
5. Move the caliper to the other end of the angle.

Presses of the **<Update>** key will toggle between active calipers, allowing you to adjust the position of the three points that make up the angle.

6. Press the **<Set>** key to fix the third point and complete the angle measurement.

#### **8.1.1.4. Volume**

Volume can be measured with 3 Distances or 1 Ellipse+1 distance method.

##### **3-Distance Method:**

1. Invoke the generic measurement function.
2. Select **Volume-> Volume 3 Dist.**
3. Move the caliper to the start point.
4. Press the **<Set>** key to fix the start point.
5. Move the caliper to the end point.  
Presses of the **<Update>** key will toggle between active calipers, allowing you to adjust the position of start point and end point.
6. Press the **<Set>** key to fix the end point and complete the measurement of the first distance.
7. Repeat step 3~6 to complete the measurements of the second and third distance. Then the Volume measurement result displays.

##### **Ellipse+ 1 Distance Method:**

1. Invoke the generic measurement function.
2. Select **Volume-> Ellipse 1 Dist.**
3. Perform one Ellipse measurement following the Ellipse method in section *8.1.1.2 Circumference/Area* measurement.
4. Perform one Distance measurement following the 2-point method in section *8.1.1.1 Distance* measurement.
5. Then the Volume measurement result displays.

#### **8.1.1.5. Stenosis**

Stenosis can be measured with Distance, Ellipse, Trace or Spline method.

##### **Distance Method:**

1. Invoke the generic measurement function.
2. Select **Distance-> Stenosis% Dist.**
3. Perform two Distance measurements following the 2-point method in section *8.1.1.1 Distance* measurement.
4. Then the Stenosis measurement result displays.

##### **Ellipse Method:**

1. Invoke the generic measurement function.
2. Select **Circ/Area-> Stenosis% Ellipse.**
3. Perform two Ellipse measurements following the Ellipse method in section *8.1.1.2 Circumference/Area* measurement.
4. Then the Stenosis measurement result displays.

##### **Trace Method:**

1. Invoke the generic measurement function.
2. Select **Circ/Area-> Stenosis% Trace.**
3. Perform two trace measurements following the Trace method in section *8.1.1.2 Circumference/Area* measurement.
4. Then the Stenosis measurement result displays.



**Spline Method:**

1. Invoke the generic measurement function.
2. Select **Circ/Area-> Stenosis% Spline**
3. Perform two spline measurements following the Spline method in section 8.1.1.2 *Circumference/Area* measurement.
4. Then the Stenosis measurement result displays.

**8.1.1.6. Elastography Ratio**

Elastography Ratio(Eratio) can measure the strain ratio between lesion and normal tissue. There are Ellipse and Trace methods.

**Ellipse Method:**

1. Invoke the generic measurement function.
2. Select **Eratio-> Eratio Ellipse**.
3. Measure the lesion (Displayed as A=XX%) following the Ellipse method in section 8.1.1.2 *Circumference/Area* measurement.
4. Measure the normal tissue (Displayed as B=XX%) following the Ellipse method in section 8.1.1.2 *Circumference/Area* measurement.
5. The system automatically calculates the strain ratio between lesion (A) and normal tissue (B). It is suggest to measure the lesion and normal tissue at the same depth.

**Trace Method:**

1. Invoke the generic measurement function.
2. Select **Eratio-> Eratio Trace**.
3. Measure the lesion (Displayed as A=XX%) following the Trace method in section 8.1.1.2 *Circumference/Area* measurement.
4. Measure the normal tissue (Displayed as B=XX%) following the Trace method in section 8.1.1.2 *Circumference/Area* measurement.
5. The system automatically calculates the strain ratio between lesion (A) and normal tissue (B). It is suggest to measure the lesion and normal tissue at the same depth.

**8.1.2. M-mode Generic Measurements**

The generic measurements supported in M-mode are listed in the table below.

No.	Measurement Group	Measurement Item	Remark
1.	Generic	Distance	2-point method
		Slope	
		Time	
		HR	

**8.1.2.1. Distance**

The distance measurement measures the distance between two points at the vertical direction. To measure the distance:

1. Invoke the generic measurement function.
2. Select **Dist. 2 Point**.
3. Move the caliper to the start point.

4. Press the **<Set>** key to fix the start point.
5. Move the caliper to the end point.  
Presses of the **<Update>** key will toggle between active calipers, allowing you to adjust the position of start point and end point.
6. Press the **<Set>** key to fix the end point and complete the measurement.

### **8.1.2.2. Slope**

The Slope measurement measures the distance and time between two points, and calculates the slope. To measure Slope:

1. Invoke the generic measurement function.
2. Select **Slope**.
3. Move the caliper to the start point.
4. Press the **<Set>** key to fix the start point.
5. Move the caliper to the end point.  
Presses of the **<Update>** key will toggle between active calipers, allowing you to adjust the position of start point and end point.
6. Press the **<Set>** key to fix the end point and complete the measurement.

### **8.1.2.3. Time**

The Time measurement measure the time interval between two points. To measure Time:

1. Invoke the generic measurement function.
2. Select **Time**.
3. Move the caliper to the start point.
4. Press the **<Set>** key to fix the start point.
5. Move the caliper to the end point.  
Presses of the **<Update>** key will toggle between active calipers, allowing you to adjust the position of start point and end point.
6. Press the **<Set>** key to fix the end point and complete the measurement.

### **8.1.2.4. HR**

The HR measurement measures the time interval between two points, and calculates the heart rate. To measure HR:

1. Invoke the generic measurement function.
2. Select **HR**.
3. Move the caliper to the first heartbeat.
4. Press the **<Set>** key to fix the start point.
5. Move the caliper to the next beat.  
Presses of the **<Update>** key will toggle between active calipers, allowing you to adjust the position of start point and end point.
6. Press the **<Set>** key to fix the end point and complete the measurement.

### 8.1.3. Strip Doppler Generic Measurements

The generic measurements supported in strip Doppler mode are listed in the table below.

No.	Measurement Group	Measurement Item	Remark
1.	Generic	PS	
		ED	
		RI	
		PI	
		PS,ED,RI,S/D	
		Time	
		HR	
		Manual Trace	
		Auto Trace	
		Spline Trace	
2.	Generic	Velocity	Only available for Cardiac exam
		Manual Trace	
		Spline Trace	
		HR	
		Time	
		PGMax	
		PGMean	
3.	Vessel	Vol Flow	Auto Trace method
4.	Tei index	COT	Only available for Cardiac exam
		ET	

#### 8.1.3.1. Velocity

Multiple types of velocity measurements are supported on Doppler Strip, for example velocity at any point, at PS or ED.

**Velocity:** measures the velocity at any point on the strip, and calculates PG.

1. Invoke the generic measurement function.
2. Select **Generic-> Velocity**.
3. Move the caliper to the desired point on the strip.
4. Press the **<Set>** key to fix the point, and then Velocity and PG results display.

**PS/ED:** measures the velocity at PS and ED points.

1. Invoke the generic measurement function.
2. Select **Generic-> PS or ED.**
3. Move the caliper to the PS or ED point on the strip.
4. Press the **<Set>** key to fix the point, and then PS or ED result displays.

**RI:** measures the velocity at PS and ED points, and calculates RI result.

1. Invoke the generic measurement function.
2. Select **Generic-> RI.**
3. Move the caliper to the PS point.
4. Press the **<Set>** key to fix the PS point.
5. Move the caliper to the ED point.

Presses of the **<Update>** key will toggle between active calipers, allowing you to re-position the PS point or ED point.

6. Press the **<Set>** key to fix the ED point and complete the measurement.

**S/D:** measures the velocity at PS and ED points, and calculates S/D result.

1. Invoke the generic measurement function.
2. Select **Generic-> PS, ED, RI, S/D.**
3. Move the caliper to the PS point.
4. Press the **<Set>** key to fix the PS point.
5. Move the caliper to the ED point.

Presses of the **<Update>** key will toggle between active calipers, allowing you to re-position the PS point or ED point.

6. Press the **<Set>** key to fix the ED point and complete the measurement.

### 8.1.3.2. Trace

The Trace measurement can provide a wide range of results, as shown below. The actual results displayed will depend on Measure Setup(See section 10.4 for details).

- PS
- ED
- MD
- TAMax
- PGmax
- PGmean
- PI
- RI
- S/D
- VTI
- Time
- AT
- DT
- HR

Trace measurement is only available on a frozen strip. There are Manual Trace, Spline Trace and Auto Trace methods.

**Manual Trace Method:**

1. Freeze the strip and invoke the generic measurement function.
2. Select **Generic-> Manual Trace**.
3. Move the caliper to the start point.
4. Press the **<Set>** key to fix the start point and start drawing the trace.
5. Moving the caliper to mark the trace outline.

Presses of the **<Update>** key will toggle between active calipers, allowing you to adjust the positions of the PS or ED points in the trace.

6. Press the **<Set>** key to complete the trace.

**Spline Trace Method:**

1. Freeze the strip and invoke the generic measurement function.
2. Select **Generic-> Spline Trace**.
3. Move the caliper to the desired location.
4. Press the **<Set>** key to place the first point.
5. Repeat step 3-4 to place other points. A trace will be created after three points are placed.
6. If a point is not placed satisfactorily, press **Undo** button to remove it. Each press of **Undo** button removes one point.
7. Double press the **<Set>** key to complete the trace.

**Auto Trace Method:**

1. Freeze the strip and invoke the generic measurement function.
2. Select **Generic-> Auto Trace**.
3. The trace waveform(s) automatically appear, and measurement result displays.

**NOTE:**

1. Auto trace measurement can only be activated on a frozen Doppler strip.
2. Live Auto Trace is available as a separate feature on the Doppler touch screen. To activate Auto Trace in real time mode, press **Auto Trace** button on PW touch screen.

**8.1.3.3. Time**

The steps of time measurement are the same as those of time measurement in M mode. Please refer to *section 8.1.2.3* for details.

**8.1.3.4. HR**

The steps of HR measurement are the same as those of HR measurement in M mode. Please refer to *section 8.1.2.4* for details.

**8.1.3.5. PI(Pulse Index)**

PI measurement can be measured with manual trace method. To measure PI:

1. Freeze the strip and invoke the generic measurement function .
2. Select **Generic-> PI**.

3. Move the caliper to the start point.
4. Press the **<Set>** key to fix the start point and start drawing the trace.
5. Moving the caliper to mark the trace outline.

Presses of the **<Update>** key will toggle between active calipers, allowing you to adjust the positions of the PS or ED points in the trace.

6. Press the **<Set>** key to complete the trace..

### 8.1.3.6. PG(Pressure Gradient)

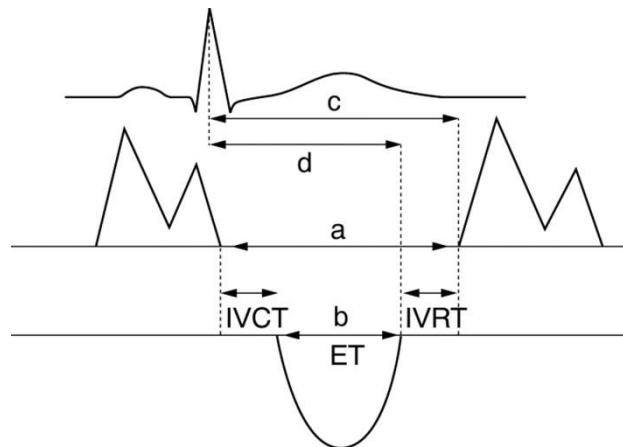
PGmax and PGmean can be measured in Cardiac exams. The measurement method is manual trace. Please refer to the steps of manual trace method in *section 8.1.3.2 trace* measurement for details.

### 8.1.3.7. Tei Index

The Tei index measurement is useful for the assessment of ventricular systolic and diastolic function. Higher Tei index indicates decreased ventricular function.

To use the TEI measurement:

1. In Cardiac exams, invoke the generic measurement function on a Doppler strip.
2. Select **Tei Index**.
3. Measure **COT** (Mitral Valve Close-Open Duration ) by caliper pairs.
4. Measure **ET** (Ventricular Ejection Time) by caliper pairs.
5. The system calculates the Tei index automatically. The illustration is shown below:



$$\text{Index} = \frac{a - b}{b} = \frac{(\text{IVCT} + \text{IVRT})}{\text{ET}}$$

## **8.2 Application Measurements**

Application Measurements have a pre-defined meaning and can be entered into a report. The system supports the following application measurement packages, each with its own set of measurements, calculations and report:

- OB (including multiple fetuses)
- Abd
- Vascular
- Cardiac
- Gynecology
- Small Parts
- Urology
- Pediatric(including Neonatal)

When you select an application measurement from the touch screen it will automatically invoke the type of measurement it needs. For example, if you select “BPD” from the OB application it will automatically invoke a distance measurement. These measurements generally behave as described above for generic measurements. When the measurement is complete, the measurement results will enter into the report automatically.

Some application measurements can have multiple variations. For example, in a twin OB exam the OB measurements can be done on either fetus. As another example, in Vascular exams several measurements can be done in a Proximal, Mid, or Distal location. When a measurement has multiple variations you will see paddle keys on the touch screen that let you pick which variation you are measuring.

Please refer to the Advanced User Manual for the calculation formulas and references.

**8.2.1. Abdomen Measurements**

No.	Measurement Group	Measurement Item	Description	Method
<b>Section 1: B-mode Measurements</b>				
1.1	Liver	Liver L	Liver Length	Distance in B-mode generic measurements
		Liver W	Liver Width	
		Liver H	Liver Height	
		Portal Vein	Portal Vein Diameter	
		CHD	Common Hepatic Duct	
1.2	Gall Bladder	GB L	Gallbladder Length	
		GB H	Gallbladder Height	
		GB wall th	Gallbladder wall thickness	
		CBD	Common Bile Duct	
1.3	Pancreas	Panc duct	Pancreatic duct	
		Panc head	Pancreatic head	
		Panc body	Pancreatic body	
		Panc tail	Pancreatic tail	
1.4	Spleen	Spleen L	Spleen Length	
		Spleen H	Spleen Height	
1.5	Renal	Renal L	Renal Length	
		Renal W	Renal Width	
		Renal H	Renal Height	
		Cortex	Renal Cortex thickness	
1.6	Aorta Diam		Aorta Diameter	
<b>Section 2: Doppler Measurements</b>				
2.1	AA	PS ED RI PI PS,ED,RI,S/D Time HR Auto Trace Manual Trace Spline Trace	Abdominal Aorta	Doppler generic measurements
2.2	SMA		Superior Mesenteric Artery	
2.3	IMA		Inferior Mesenteric Artery	
2.4	HA		Hepatic Artery	
2.5	Splenic A		Splenic Artery	
2.6	Renal A		Renal Artery	
2.7	Portal V		Portal Vein	Velocity in Doppler generic measurements
2.8	IVC		Inferior Vena Cava	
2.9	M Portal V		Main Portal Vein	
2.10	Hepatic V		Hepatic Vein	
2.11	M Hepatic V		Middle Hepatic Vein	



No.	Measurement Group	Measurement Item	Description	Method
2.12	Splenic V		Splenic Vein	
2.13	SMV		Superior Mesenteric Vein	
2.14	IMV		Inferior Mesenteric Vein	

### 8.2.2. Gynecology Measurements

No.	Measurement Group	Measurement Item	Description	Method
<b>Section 1: B-mode Measurements</b>				
1.1	Uterus	Uterus L	Uterus Length	Distance in B-mode generic measurements
		Uterus W	Uterus Width	
		Uterus H	Uterus Height	
		Endo	Endometrium Thickness	
		UT-Cavity	Uterine Cavity Depth	
1.2	Cervix	Cervix L	Cervix Length	
		Cervix W	Cervix Width	
		Cervix H	Cervix Height	
1.3	Ovary	Ovary L	Ovary Length	
		Ovary W	Ovary Width	
		Ovary H	Ovary Height	
1.4	Cyst*	Cyst D1	Cyst Distance 1	
		Cyst D2	Cyst Distance 2	
		Cyst D3	Cyst Distance 3	
1.5	Follicle*	Fol. D1	Follicle Distance 1	
		Fol. D2	Follicle Distance 2	
		Fol. D3	Follicle Distance 3	
1.6	Fluid POD		Fluid Pouch of Douglas	
<b>Section 2: Doppler Measurements</b>				
2.1	Ovary A	PS ED RI PI PS,ED,RI,S/D Time	Ovary Artery	Doppler generic measurements
2.2	Ut. A	HR Auto Trace Manual Trace	Uterine Artery	

<b>No.</b>	<b>Measurement Group</b>	<b>Measurement Item</b>	<b>Description</b>	<b>Method</b>
		Spline Trace		

\* The measurement method including 1 Distance, 2 Distances and 3 Distances can be configured in Measure Preset. See Section 10.4.1 for details.

### **8.2.3. Obstetrics Measurements**

Obstetric measurements are used to calculate the GA (Gestation Age), EDD (Estimated Delivery Date) and EFW (Estimated Fetus Weight).

The Obstetric package supports measurements and reports on up to four fetuses. If you know the number of fetuses at the start of the exam then you can enter this in the Patient page (see section 4.4). When the number of fetuses is known the system adjusts the user interface to optimize for that number. If no information is entered about the number of fetuses the system will assume there is one.

Except where noted below, every measurement and calculation supports multiple fetuses.

<b>No.</b>	<b>Measurement Group</b>	<b>Measurement Item</b>	<b>Description</b>	<b>Method</b>
<b>Section 1: B-mode Measurements</b>				
1.1	Fetal Biometry	BPD	Biparietal Diameter	Distance in B-mode generic measurements
		HC	Head Circumference	Ellipse in B-mode generic measurements
		AC	Abdominal Circumference	
		FL	Femur Length	Distance in B-mode generic measurements
		HUM	Humerus Length	
		CER	Cerebellum Diameter	
		OFD	Occipital Frontal Diameter	
		NF	Nuchal Fold	
		TAD	Transverse Abdominal Diameter	
		APAD	Anteroposterior Abdominal Diameter	
		THD	Thoracic Diameter	
		APTD	Anteroposterior Trunk Diameter	
		TTD	Transverse Trunk Diameter	
FTA	Fetal Trunk Area	Ellipse in B-mode generic measurements		

<b>No.</b>	<b>Measurement Group</b>	<b>Measurement Item</b>	<b>Description</b>	<b>Method</b>	
1.2	Early Gest	CRL	Crown Rump Length	Distance in B-mode generic measurements	
		BPD	Biparietal Diameter	Distance in B-mode generic measurements; Auto(See 8.2.3.1)	
		FL	Femur Length		
		HUM	Humerus Length		
		NT	Nuchal Translucency	Distance in B-mode generic measurements; Auto(See section 8.2.3.2)	
		GS	Gestational Sac	Distance in B-mode generic measurements	
		YS	Yolk Sac		
AF	Deepest Pocket				
1.3	Lone Bones	HUM	Humerus Length	Distance in B-mode generic measurements; Auto(See section 8.2.3.1)	
		ULNA	Ulna Length	Distance in B-mode generic measurements	
		RAD	Radius Length		
		TIB	Tibia Length		
		FIB	Fibula Length		
		Foot	Foot Length		
1.4	Fetal Cranium	CER	Cerebellum Diameter	Distance in B-mode generic measurements	
		NT	Nuchal Translucency		
		NF	Nuchal Fold		
1.5	AFI	Q1	Amniotic Fluid Index		Distance in B-mode generic measurements
		Q2			
		Q3			
		Q4			
1.6	Chamber	LV Diam	Left Ventricular Diameter	Distance in B-mode generic measurements	
		LA Diam	Left Atrium Diameter		
		RV Diam	Right Ventricular Diameter		
		RA Diam	Right Atrium Diameter		

No.	Measurement Group	Measurement Item	Description	Method
1.7	LVOT/AO	LVOT Diam	Left Ventricular Outflow Tract Diameter	
		Ao Asc	Ascending Aorta Diameter	
		Ao Arch	Aorta Arch Diameter	
		Ao Isthmus	Aorta Isthmus Diameter	
		Desc Ao	Descending Aorta Diameter	
1.8	RVOT/PA	RVOT Diam	Right Ventricular Outflow Tract Diameter	
		MPA Diam	Main Pulmonary Artery	
		Ductus A	Duct Arteriosus Diameter	
1.9	CTAR	Area 1	Cardio/Thorax area ratio	Trace in B-mode generic measurements
		Area 2		Ellipse in B-mode generic measurements
<b>Section 2: Doppler Measurements</b>				
2.1	MCA	PS ED RI PI PS,ED,RI,S/D Time HR Auto Trace Manual Trace Spline Trace	Middle Cerebral Artery	Doppler generic measurements
2.2	Umb. A		Umbilical Artery	
2.3	Placenta A		Placenta Artery	
2.4	Ovary A		Ovary Artery	
2.5	Ut. A		Uterine Artery	
2.6	Fetal Ao		Fetal Aorta	
2.7	Desc Aorta		Descending Aorta	
2.8	Ductus V		Ductus Venosus	Velocity in Doppler generic measurements
2.9	FHR		Fetal Heart Rate	
2.10	MV		Mitral Valve	
2.11	TV		Tricuspid Valve	
2.12	MPV		Main Pulmonary Vein	
2.13	Ductus A		Fetal Aorta	
<b>Section 3: M-mode Measurements</b>				
3.1	FHR		Fetal Heart Rate	HR in M generic measurements

### 8.2.3.1. Auto OB Measurement

Auto OB is a method designed to measure BPD, HC, HUM and FL automatically.

To use Auto OB measurement:

1. Select **OB** exam preset and perform image scanning in B mode.
2. Freeze the image when a standard fetal image is obtained.
3. Press <**Measure**> key on the console.
4. Select the desired measurement item **BPD, HC, HUM** or **FL** on the touch screen.
5. If **Auto** is not the default tool, press **Tool Options** to switch to Auto.
6. The auto measurement process starts. The result is displayed on the main screen.
7. If you are not satisfied with the measurement result, press <**Update**> key to switch the active caliper and use trackball to do manual correction.
8. Double press <**Set**> key to complete measurement.

#### **WARNING**

1. The fetal image for Auto OB measurement should be standard enough, otherwise the measurement accuracy may be affected. When no valid fetal image is recognized, the system will prompt you with "This measurement tool is unavailable."
2. Auto OB measurement is only available on a frozen image.
3. The measurement result of Auto OB is for reference only. The measurement accuracy depends on the quality of fetal image.

### 8.2.3.2. Auto NT Measurement

Auto NT is a method designed to measure the Nuchal Translucency automatically.

To use Auto NT measurement:

1. Select **Early OB** exam preset and perform image scanning in B mode.
2. Freeze the image when a standard fetal image is obtained.
3. Press <**Measure**> key on the console.
4. Select the measurement item **NT** on the touch screen.
5. If **Auto** is not the default tool, press **Tool Options** to switch to Auto.
6. The auto measurement process starts. The result is displayed on the main screen.
7. If you are not satisfied with the measurement result, press <**Update**> key to switch the active caliper and use trackball to do manual correction.
8. Double press <**Set**> key to complete measurement.

#### **WARNING**

1. The fetal image for Auto NT measurement should be standard enough, otherwise the measurement accuracy may be affected. When no valid fetal image is recognized, the system will prompt you with "This measurement tool is unavailable."
2. Auto NT measurement is only available on a frozen image.
3. The measurement result of Auto NT is for reference only. The measurement accuracy depends on the quality of fetal image.

**8.2.4. Cardiac Measurements**

No.	Measurement Group	Measurement Item	Description	Method
<b>Section 1: B-mode Measurements</b>				
1.1	LV Simpson	A4C Dias.	Left Ventricular apical four-chamber views at End-diastole	Simpson (See section 8.2.4.1)
		A4C Sys.	Left Ventricular apical four-chamber views at End-systole	
		A2C Dias.	Left Ventricular apical two-chamber views at End-diastole	
		A2C Sys.	Left Ventricular apical two-chamber views at End-systole	
1.2	LV/RV	RVAWd	Right Ventricular Anterior Wall Thickness at End-diastole	Distance in B-mode generic measurements
		RVIDd	Right Ventricular Internal Diameter at end-diastole	
		IVSTd	Interventricular Septal Thickness at End-diastole	
		IVSTs	Interventricular Septal Thickness at End-systole	
		LVIDd	Left Ventricular Internal Diameter at End-diastole	
		LVIDs	Left Ventricular Internal Diameter at End-systole	
		LVPWd	Left Ventricular Posterior Wall Thickness at End-diastole	
		LVPWs	Left Ventricular Posterior Wall Thickness at End-systole	
1.3	AO	AoD	Aortic Root Diameter	
		Ao Asc	Ascending Aorta Diameter	
1.4	RVOT	RVOT Diam	Right Ventricular Outflow Tract	
1.5	LVOT	LVOT Diam	Left Ventricular Outflow Tract	
1.6	PV	PV Diam	Pulmonary Valve Diameter	
1.7	RVDs		Right Ventricular Diameter at end-systole	
1.8	LA/RA	RA Length	Right Atrium Length Diameter	

No.	Measurement Group	Measurement Item	Description	Method
		RA Width	Right Atrium Width Diameter	
		LA Length	Left Atrium Length Diameter	
		LA Width	Left Atrium Width Diameter	
1.9	PISA	MR Rad	Mitral Valve Stenosis Radius	PISA (See section 8.2.4.2)
		MR Als. Vel	Mitral Regurgitation Aliasing Maximum Velocity	
		AR Rad	Aortic Valve Stenosis Radius	
		AR Als. Vel	Aortic Regurgitation Aliasing Maximum Velocity	
		TR Rad	Tricuspid Valve Stenosis Radius	
		TR Als. Vel	Tricuspid Regurgitation Aliasing Maximum Velocity	
		PR Rad	Pulmonary Valve Stenosis Radius	
		PR Als. Vel	Pulmonary Regurgitation Aliasing Maximum Velocity	
<b>Section 2: Doppler Measurements</b>				
2.1	Mitral Valve	E/A	E-wave Velocity/ A-wave Velocity	Doppler generic measurements
		MV PHT	Mitral Valve Pressure Half Time	
		MV Trace	Mitral Valve Trace	
		IVRT	Isovelocity Relaxation Time	
		MV A Dur	Mitral Valve A-wave Duration	
		MV DecT	Mitral Valve Deceleration Time	
2.2	Tricuspid Valve	TV Trace	Tricuspid Valve Trace	
		TV Vmax	Tricuspid Valve Maximum Velocity	
2.3	AoV(Aortic Valve)	LVOT Trace	Left ventricular outflow tract Trace	
		LVOT Vmax	Left ventricular outflow tract maximum Velocity	
		AoV Trace	Aortic Valve Trace	
		AoV Vmax	Aortic Valve maximum Velocity	
2.4	PV (Pulmonic Valve)	PV Trace	Pulmonic Valve Trace	
		PV Vmax	Pulmonic Valve maximum Velocity	

<b>No.</b>	<b>Measurement Group</b>	<b>Measurement Item</b>	<b>Description</b>	<b>Method</b>
2.5	P Vein (Pulmonic Vein)	PVein S Vel	Pulmonic Veins Systole Velocity	
		PVein D Vel	Pulmonic Veins Diastole Velocity	
		PV A Vel	A Point Reverse Velocity	
2.6	PISA	MR Trace	Mitral Valve Trace	PISA (See section 8.2.4.2)
		AR Trace	Aortic Valve Trace	
		TR Trace	Tricuspid Valve Trace	
		PR Trace	Pulmonary Valve Trace	
2.7	HR		Heart rate	HR in Doppler generic measurements
<b>Section 3: M-mode Measurements</b>				
3.1	LV/RV	RVAWd	Right Ventricular Anterior Wall Thickness at End-diastole	M-mode generic measurements
		RVIDd	Right Ventricular Internal Diameter at end-diastole	
		IVSTd	Interventricular Septal Thickness at End-diastole	
		LVIDd	Left Ventricular Internal Diameter at End-diastole	
		LVPWd	Left Ventricular Posterior Wall Thickness at End-diastole	
		IVSTs	Interventricular Septal Thickness at End-systole	
		LVIDs	Left Ventricular Internal Diameter at End-systole	
		LVPWs	Left Ventricular Posterior Wall Thickness at End-systole	
3.2	LVET		Left Ventricular Ejection Time	
3.3	MV(Mitral Valve)	E-F Slope	Mitral Valve E-F slope	
		EPSS	E point septal separation	
3.4	LA/Ao	LA	Left atrial diameter	
		AoD	Aortic root diameter	
		RVOT Diam	Right Ventricular outflow tract	
3.5	HR		Heart rate	

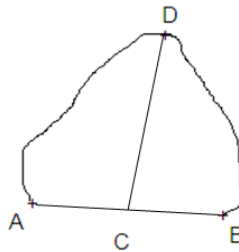


### 8.2.4.1. Simpson's Method of Disks (MOD)

Simpson's MOD is a method used to calculate LV diastolic and systolic volumes and ejection fraction. Simpson's MOD is available in the Cardiac presets.

To use the Simpson's MOD measurement:

1. Invoke the B-mode application measurement function.
2. Select **LV Simpson** measurement on the touch screen and then select one measurement label from **A4C Dias.**, **A4C Sys.**, **A2C Dias.**, and **A2C Sys.**. A single caliper will be displayed on the image field.
3. Move the caliper and press <Set> key to position the start point A at one end of left ventricular long axis.
4. Draw the trace along the endocardium of the left ventricular.
5. Press <Set> key to fix the end point B and complete the trace. A new caliper positions automatically at the apex (Point D) of the trace, connecting the Point C (Midpoint of point A and B). This distance between point C and D is the longest detected by the system, as shown below:



6. Pivot the Point D to a new desired position if necessary.
7. Press <Set> key to complete the measurement.

### 8.2.4.2. PISA

PISA (Proximal Isovelocity Surface Area) is a tool in Cardiac presets used for quantitative analysis of regurgitation. It is only available in Color and Doppler mode.

To use PISA measurement in Color mode:

1. Adjust the color image until the aliasing appears. Invoke the application measurement function.
2. Select **PISA** measurement on the touch screen and then select a measurement label from **MR Rad**, **MR Als. Vel**, **AR Rad**, **AR Als. Vel**, **TR Rad**, **TR Als. Vel**, **PR Rad** and **PR Vis. Vel**. A single caliper will be displayed on the image field.
3. Move the caliper and press <Set> key to position the caliper as the center of the semicircular.
4. Move the trackball to adjust the radius length and orientation of the semicircular.
5. Press <Set> key to fix the semicircular and then a dialog box of "Color Aliasing Velocity" pops up.
6. Select "Top aliasing velocity", "Bottom aliasing velocity", or manually enter the aliasing velocity from 0 cm/s to 500 cm/s.
7. Click OK and then measurement results are shown.

To use PISA measurement in Doppler mode:

1. Freeze a strip image. Invoke the application measurement function.
2. Select **PISA** measurement on the touch screen and then select a measurement label from **MR Trace**, **AR Trace**, **TR Trace** and **PR Trace**.
3. Use the Doppler trace tool to get the measurement results.

**8.2.5. Small Parts Measurements**

No.	Measurement Group	Measurement Item	Description	Method
<b>Section 1: B-mode Measurements</b>				
1.1	Thyroid	THY L	Thyroid Length	Distance in B-mode generic measurements
		THY W	Thyroid Width	
		THY H	Thyroid Height	
		Isthmus	Thyroid Isthmus	
1.2	Breast	Lesion 1	Breast Lesion 1	
		Lesion 2	Breast Lesion 2	
		Lesion 3	Breast Lesion 3	
		Lesion 4	Breast Lesion 4	
		Lesion 5	Breast Lesion 5	
1.3	Testis	Testis L	Testis Length	
		Testis W	Testis Width	
		Testis H	Testis Height	
<b>Section 2: Doppler Measurements</b>				
2.1	STA	PS ED RI PI PS,ED,RI,S/D Time HR	Superior Thyroid Artery	Doppler generic measurements
2.2	ITA	Auto Trace Manual Trace Spline Trace	Inferior Thyroid Artery	

**8.2.6. Urology Measurements**

<b>No.</b>	<b>Measurement Group</b>	<b>Measurement Item</b>	<b>Description</b>	<b>Method</b>
<b>Section 1: B-mode Measurements</b>				
1.1	Renal	Renal L	Renal Length	Distance in B-mode generic measurements
		Renal W	Renal Width	
		Renal H	Renal Height	
		Cortex	Renal Cortex thickness	
1.2	Bladder	Pre-BL L	Pre-void Bladder Length	
		Pre-BL W	Pre-void Bladder Width	
		Pre-BL H	Pre-void Bladder Height	
		Post-BL L	Post-void Bladder Length	
		Post-BL W	Post-void Bladder Width	
		Post-BL H	Post-void Bladder Height	
1.3	Prostate	Prostate L	Prostate Length	
		Prostate W	Prostate Width	
		Prostate H	Prostate Height	
1.4	Seminal	Seminal L	Seminal Length	
		Seminal W	Seminal Width	
		Seminal H	Seminal Height	
1.5	Testis	Testis L	Testis Length	
		Testis W	Testis Width	
		Testis H	Testis Height	
<b>Section 2: Doppler Measurements</b>				
2.1	Renal A	PS ED RI PI PS,ED,RI,S/D Time HR Auto Trace Manual Trace Spline Trace	Renal Artery	Doppler generic measurements
2.2	Arcuate A		Arcuate Artery	
2.3	Seg. A		Segmental Artery	
2.4	Int. A		Interlobar Artery	

### 8.2.7. Vascular Measurements

No.	Measurement Group	Measurement Item	Description	Method
<b>Section 1: B-mode Measurements</b>				
1.1	CCA	IMT Far	Common Carotid Artery Intima-Media Thickness (Far vessel wall)	Distance in B-mode generic measurements; Auto(See section 8.2.7.1).
		IMT Near	Common Carotid Artery Intima-Media Thickness (Near vessel wall)	
1.2	ICA	IMT Far	Internal Carotid Artery Intima-Media Thickness (Far vessel wall)	
		IMT Near	Internal Carotid Artery Intima-Media Thickness (Near vessel wall)	
1.3	BIF	IMT Far	Carotid Artery Bifurcation Intima-Media Thickness (Far vessel wall)	
		IMT Near	Carotid Artery Bifurcation Intima-Media Thickness (Near vessel wall)	
1.4	VF Area		Volume Flow Area	Distance in B-mode generic measurements
<b>Section 2: Doppler Measurements</b>				
2.1	CCA	PS ED RI PI PS,ED,RI,S/D Time HR Auto Trace Manual Trace Spline Trace	Common Carotid Artery	Doppler generic measurements
2.2	ECA		External Carotid Artery	
2.3	ICA		Internal Carotid Artery	
2.4	Vert A		Vert Artery	
2.5	SUBC A		Subclavian Artery	
2.6	Axill A		Axillary Artery	
2.7	Brach A		Brachial Artery	
2.8	Ulnar A		Ulnar Artery	
2.9	Radial A		Radial Artery	
2.10	CFA		Common Femoral Artery	
2.11	DFA		Deep Femoral Artery	
2.12	SFA		Superficial Femoral Artery	

<b>No.</b>	<b>Measurement Group</b>	<b>Measurement Item</b>	<b>Description</b>	<b>Method</b>
2.13	CIA		Common Iliac Artery	
2.14	EIA		External Iliac Artery	
2.15	IIA		Internal Iliac Artery	
2.16	Pop A		Popliteal Artery	
2.17	Peron A		Peroneal Artery	
2.18	PTA		Posterior Tibial Artery	
2.19	ATA		Anterior Tibial Artery	
2.20	DPA		Dorsalis Pedis Artery	
2.21	SUBC V		Subclavian Vein	Velocity in Doppler generic measurements
2.22	Axill V		Axillary Vein	
2.23	Brach V		Brachial Vein	
2.24	Cepha V		Cephalic Vein	
2.25	Basilic V		Basilic Vein	
2.26	Ulnar V		Ulnar Vein	
2.27	Radial V		Radial Vein	
2.28	M Cubital V		Median Cubital Vein	
2.29	CFV		Common Femoral Vein	
2.30	DFV		Deep Femoral Vein	
2.31	SFV		Superficial Femoral Vein	
2.32	CIV		Common Iliac Vein	
2.33	EIV		External Iliac Vein	
2.34	IIV		Internal Iliac Vein	
2.35	Saph V		Great Saphenous Vein	
2.36	Pop V		Popliteal Vein	
2.37	Peron V		Peroneal Vein	
2.38	PTV		Posterior Tibial Vein	
2.39	ATV		Anterior Tibial Vein	
2.40	SSV		Small Saphenous Vein	
2.41	HR		Heart Rate	HR in Doppler generic measurements
2.42	Vol Flow		Volume Flow	Auto Trace

### 8.2.7.1. Auto IMT

Intima-media thickness (IMT) is a measurement of the thickness of tunica intima and tunica media. The system provides an automatic measurement of the Carotid IMT.

To measure IMT:

1. Invoke the B-mode application measurement in Carotid Preset.
2. Select an IMT measurement on the touch screen. A ROI box will be displayed on the image field.
3. Press the **Distance** paddle key to select a different position of carotid artery.
4. Press <**Update**> key and Use the trackball to adjust the size of ROI box.
5. Press <**Update**> key again to confirm the size of ROI box.
6. Use the trackball to move the ROI box to desired measurement location, and then the system automatically displays the IMT measurement results.
7. Press <**Set**> key to complete measurement and save the results in the worksheet.
8. If you are not satisfied with the measurement result, press **Tool Options** to switch to **Distance** tool and do the IMT measurement manually.
9. The IMT measurement can display the following result:
  - Max (the maximum value of the IMT results)
  - Min (the minimum value of the IMT results)
  - Avg (the average value of the IMT results)
  - Width (the width of the ROI box)
  - SD (the Standard Deviation of the IMT results)
  - Points (the number of valid points in the IMT results)

---

#### **WARNING**

1. Auto IMT measurement can only be activated on a frozen image.
  2. Select the Right or Left, Near or Far vessel wall, and vessel segment before generating IMT measurement, otherwise the measurement results may not be accurate.
  3. Always confirm the IMT is correctly traced prior to entering the IMT result into the report.
-

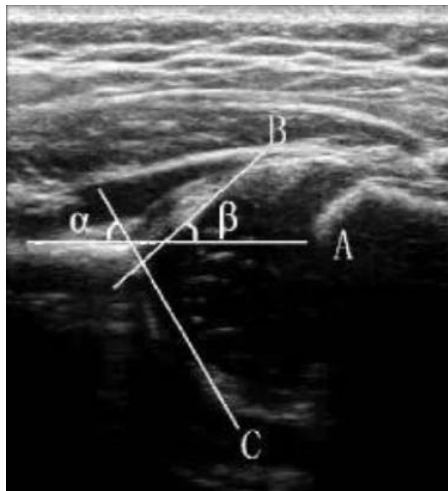
## 8.2.8. Pediatric Measurements

No.	Measurement Group	Measurement Item	Description	Method
<b>Section 1: B-mode Measurements</b>				
1.1	LLV		Left lateral ventricle	Distance in B-mode generic measurements
1.2	RLV		Right lateral ventricle	
1.3	LT Tri		Left trigone	
1.4	RT Tri		Right trigone	
1.5	HIP	HIP Angle	Hip joint angle	Hip Joint(See section 8.2.8.1)
		HIP d/D	Hip joint d/D ratio	

### 8.2.8.1. Hip Joint Measurement

#### **Hip Joint Angle Measurement:**

Hip Joint Angle Measurement is intended to evaluate the development of acetabular roof and the subluxation of femoral head for pediatrics. This measurement is performed by adding three straight lines on the anatomic image, thereby calculating two angles. See the illustration below.



- Line A (Baseline) connects the osseous acetabular convexity to the point where the joint capsule and the perichondrium unite with the iliac bone;
- Line B(Inclination Line) connects the osseous acetabular convexity to the labrum acetabulare;
- Line C(Roof Line) connects the lower edge of the iliac bone to the osseous acetabular convexity.
- $\alpha$  is the angle between baseline and roof line.
- $\beta$  is the angle between baseline and inclination line.

To use Hip Joint Angle measurement:

1. Invoke the B-mode application measurement function.
2. Select **HIP-> HIP Angle** on the touch screen and then select **Left** or **Right** on touch screen. A horizontal straight line will be displayed on the image field.
3. Use the trackball to move this horizontal straight line to place the baseline. Rotate the Angle knob on the console to adjust the angle of baseline if necessary.

4. Press <**Set**> key and the default angle  $\alpha$  and roof line comes out.
5. Move the trackball to place the roof line and rotate the Angle knob to adjust the angle  $\alpha$ .
6. Press <**Set**> key and the default angle  $\beta$  and inclination line comes out.
7. Move the trackball to place the inclination line and rotate the Angle knob to adjust the angle  $\beta$ .
8. Press <**Set**> key to complete the measurement.
9. Evaluate the type of hip joint through Graf method.

***Hip Joint d/D Ratio Measurement:***

Hip Joint d/D Ratio measurement is intended to measure the percentage of the femoral head coverage under the iliac bone roof.

To use Hip Joint d/D Ratio measurement:

1. Invoke the B-mode application measurement function.
2. Select **HIP->HIP d/D** on the touch screen and then select **Left** or **Right** on touch screen. A horizontal straight line will be displayed on the image field.
3. Use the trackball to move this horizontal straight line to place the baseline along the iliac bone. Rotate the Angle knob on the console to adjust the angle of baseline if necessary.
4. Press <**Set**> key, and a second line displays below the baseline. Move the second line to make it be tangent to the femoral head, and the "d" distance comes out.
5. Press <**Set**> key, and a third line displays above the baseline. Move the third line to make it be tangent to the femoral head, and the "D" distance and "d/D" ratio come out.



## 8.3 Worksheet and Report

Worksheet is available at any time during an exam, and is displayed as default on the main screen. Report contains the information from a worksheet but it is formatted in a slightly different manner.

### 8.3.1. Worksheet

#### 8.3.1.1. Viewing worksheet

Press **<Report>** key on the console to open worksheet screen. A worksheet includes: Patient Information, Measurement/Calculation data, Findings, Comments, etc..



Figure 8-7 Worksheet Main Screen Display

No.	Name	Description
A	Patient Information	Displays patient and doctor information, which comes from Patient Information Screen.
B	Obstetric Information	Displays information related to obstetric exam. Only displayed in Obstetric exams. See 8.3.1.3 OB worksheet for details.
C	Measurement Data	Displays all the measured and calculated data of current exam.
D	Exam Type	Selects the exam type from the drop-down list to display its measurement data.
E	Imaging Modes	<b>2D, M, Doppler:</b> Press these buttons to display or hide separate measurement data by image modes. <b>Expand:</b> Displays all available measurements of current exam preset no matter whether it is measured or not when it is on, and contracts unmeasured items when it is off. All those measured items are always displayed, regardless it is in current measure preset or not.

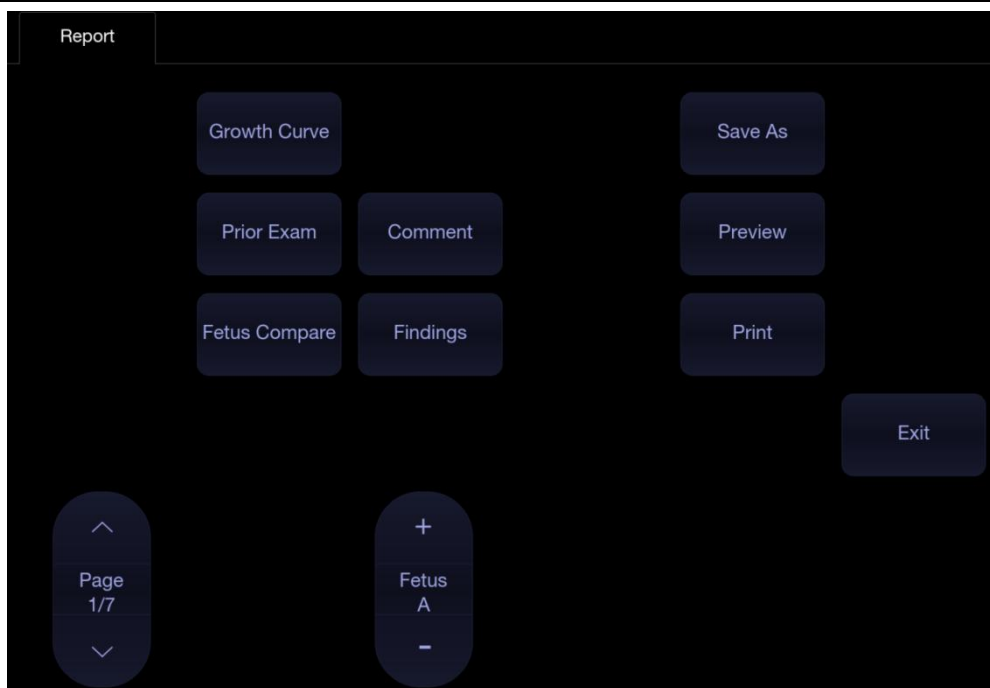


Figure 8-8 Worksheet Touch Screen Display

<b>No.</b>	<b>Name</b>	<b>Description</b>
1.	Growth Curve	Press to access the fetal growth curves. It is only available in Obstetric exams. See section <i>8.3.1.4 Growth Curve</i> for details.
2.	Prior Exams	Press to open the Prior Exam Data page for typing in prior fetus exam data. It is only available in Obstetric exams.
3.	Fetus Compare	Press to compare multiple fetus data in one page. It only shows summary data for each fetus. It is available only in multiple fetus situations.
4.	Fetus	Press to switch fetus, and worksheet main screen page shows data of selected fetus. It is only available in multiple fetus situations, and the number of enabled button equals current fetus number which is determined in patient information page.
5.	Comment	Press to display or hide comment section. This is an editable field for user to type any diagnosis or treatment comments.
6.	Findings	Press to display or hide the findings section. This is an editable field for user to type any ultrasound findings. See <i>section 8.3.1.5 Findings</i> for details.
7.	Page	Press to switch worksheet pages.
8.	Save As	Press to save the report as PDF file to external storage.
9.	Preview	Press to preview report.
10.	Print	Press to print the report via the connected USB report printer.

### 8.3.1.2. Editing Worksheet

Move the cursor over an editable field such as a measurement result, and press the <Set> key. A touch QWERTY is automatically invoked. Or, you can use the physical keyboard of the system. Type in your changes and press the Enter key to save the changes. After editing a result, an asterisk mark will be displayed as a superscript to indicate this is a manually edited value.

### 8.3.1.3. OB Worksheet

Please see section 8.3.1.1 Viewing Worksheet for an overview of worksheet. This section describes worksheet capabilities that are unique to OB.

In Obstetric exams, press <Report> key on the console to open OB worksheet, see the figure below:



Figure 8-9 OB Worksheet

No.	Name	Description
A	LMP	Displays last menstruation period of the patient. If the LMP was entered on the Patient Information page that date is transferred to here.
B	GA	Two different versions of the GA are displayed: <ul style="list-style-type: none"> <li>Clinical GA: Calculated from the LMP.</li> <li>GA(CUA) or GA(AUA): Displays Composite Ultrasound Age(CUA) or Average Ultrasound Age(AUA), depending the Default GA display configured in Measure Preset(see section 10.4 for details).</li> </ul>
C	EDD	Two different versions of the EDD are displayed based on the two GA values.
D	Reference	Click to select the equation used to calculate the GA.
E	CUA(or AUA)	These checkboxes let you decide which results are included in the CUA or AUA calculation. CUA is calculated from the selected BPD, HC, AC and/or FL measurement result; AUA is the averaged value of the selected GAs calculated from single parameter including BPD, HC, AC, FL etc. Whether CUA or AUA is displayed depends on the Default GA display configured in Measure Preset(see section 10.4 for details).

### 8.3.1.4. Growth Curve

Press the <Report> key to enter the Worksheet, and then press the **Growth Curve** button on the touch screen to display the Growth Curve Graph. Growth Curve is only available in Obstetric exams.

Growth Curve indicates predicted fetal growth patterns according to the selected reference for a measurement or calculation. A growth curve graph can display information acquired in the current exam. Multiple fetus data can be displayed in the same graphic to compare their growth trending details.

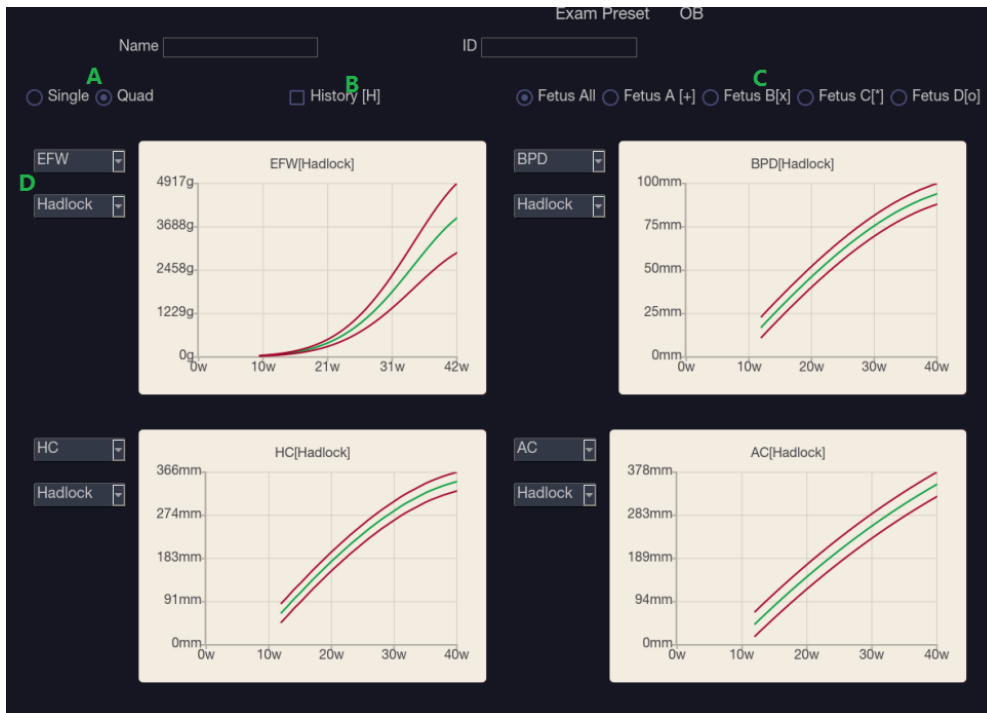


Figure 8-10 Growth Curve Graph

No.	Name	Description
A	Single/Quad	Two radio buttons for displaying single or four growth curve graphs.
B	History	If prior exam data have been typed in the Prior Exam Data page, checking this item here allows you viewing the fetus growth trending on the growth curve graph. If no prior exam data is typed in, this function is unavailable.
C	Fetus	There is a group of radio buttons to switch fetus, and the growth curve graph shows data of selected fetus. It is only available in multiple fetus situations, and the number of enabled button equals current fetus number which is determined in patient information page. Fetus All is for displaying the data of all fetus on the same growth curve graph. Fetus A/Fetus B/Fetus C/Fetus D is for switch the growth curve graph of different fetus.
D	Measurement Item/Reference	For each growth curve graph, there is a drop-down list for selecting specific measurement or calculation, and a drop-down list for selecting specific reference of selected measurement or calculation. Selecting one of them, the growth curve graph will change accordingly.

### 8.3.1.5. Findings

The findings user interface allows you to quickly create a paragraph of findings for the current exam. It consists of three interactions:

- Findings preset. It determines the pre-defined findings displayed. The default findings preset is auto linked to current measure preset. Click the Preset drop list and select one preset, for example ABD, then the pre-defined findings field shows all the pre-defined findings associated with ABD preset.
- An editable field that displays the findings for this exam. Text can be entered directly into this field by setting the cursor in the field and using the touchscreen keyboard, or by using the library of pre-defined findings.
- Pre-defined findings. This interaction shows a list of pre-defined findings. Checking the checkbox before each findings will insert it into the editable field. This list is divided into sections, and each section can be expanded/contracted using the arrow button next to the section header.

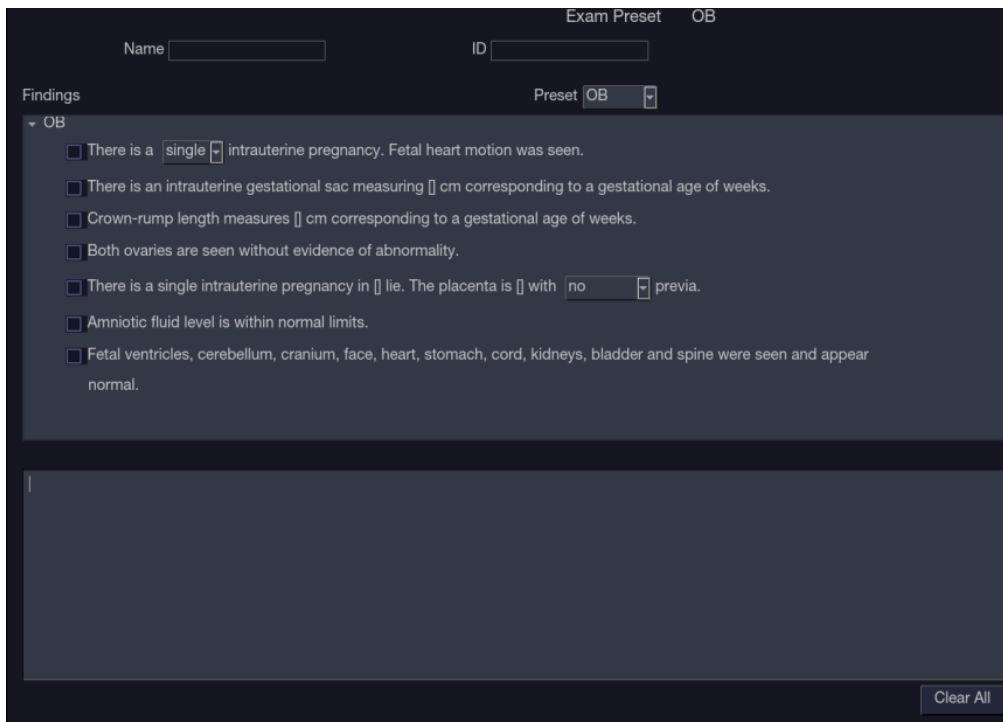


Figure 8-11 The Findings page

To customize the pre-defined findings:

- Export the findings to an USB stick as described in section 11.3.4. The findings will be saved to the Findings folder following the path Ultra Settings→Trolley HL9.
- Open the findings file on a PC, using Excel, or any text-editing program.
- Edit the pre-defined findings. Be careful to follow the established format regarding the headers of each section and the section contents.
- Save the file back to the USB stick. Make sure the file extension remains .txt. Depending on the program you are using this may require using the “Save As...” option and selecting the Plain Text format.
- Import the findings back into the system using the same interface described in section 11.3.4.

### 8.3.2. Report

A report includes: Header, Patient Information, Images, Measurement/Calculation data, Comments, Findings and Sonographer signature. If images are stored in current exam, selecting images displayed on the right side of main screen will add the selected images into the report.

Press **Preview** on the touch screen to preview the report, as shown below:

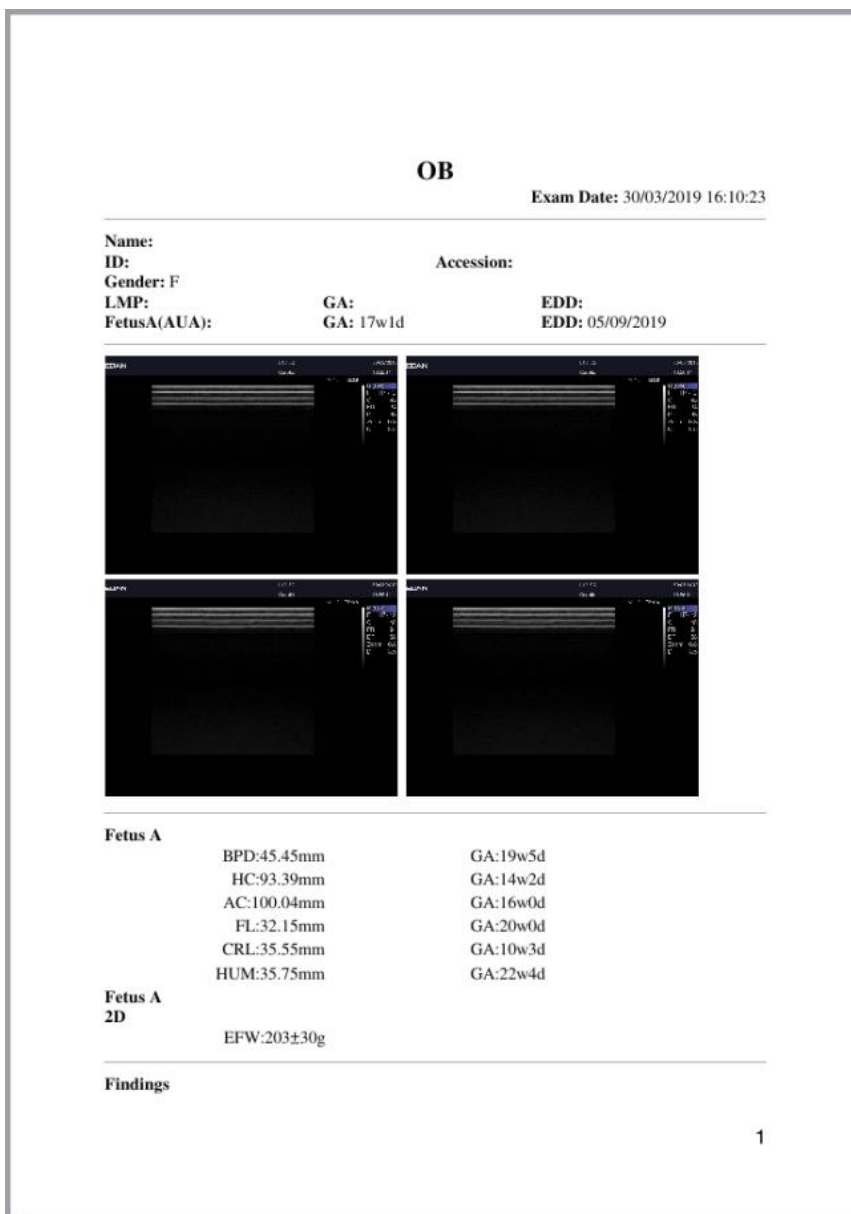


Figure 8-12 General Layout of Report

Press **Save As** on the touch screen to store the report as PDF file to external storage.

Press **Print** on the touch screen to print the report via the connected USB report printer.

## 8.4 Measurement Accuracy




<i>Parameter</i>	<i>Range</i>	<i>Accuracy</i>
<b>1.B Mode Measurement</b>		
Distance	Full Screen	< $\pm 5\%$
Circumference (Ellipse)	Full Screen	< $\pm 5\%$
Circumference (Trace)	Full Screen	< $\pm 5\%$
Area (Ellipse)	Full Screen	< $\pm 10\%$
Area (Trace)	Full Screen	< $\pm 10\%$
Angle	Full Screen	< $\pm 3\%$
<b>2. M Mode Measurement</b>		
Distance	Full Screen	< $\pm 5\%$
Time	Timeline display	< $\pm 5\%$
HR	Timeline display	< $\pm 5\%$
<b>3. Doppler Mode Measurement</b>		
Velocity(PW mode)	10-200cm/s	When angle $\leq 60^\circ$ , < $\pm 10\%$
Velocity(CW mode)	10-200cm/s	When angle $\leq 60^\circ$ , < $\pm 10\%$
Time	Timeline display	< $\pm 5\%$
HR	Timeline display	< $\pm 5\%$

# 9 Exam Data Management

## 9.1 Storing Images

The system supports storing static images and cine clips. What is displayed in Information area, Image area and Image parameter area on the main screen will be stored.

The control panel has two store keys and one print key, as shown below:


No.	Key	Name	Default Function
1		Store Image (Store 1)	Stores static images.
2		Store Clip (Store 2)	Stores cine clips.
3		Print	Prints images via the connected USB video printer.

Each of these three keys can be separately configurable to support any of the following functions. See section 11.1.3 for details.

- Store a static image.
- Store a clip.
- Video print function


### Storing an image:




Pressing the  hard key on the console will always capture what is on the image area of the screen. This includes live, frozen, or Cine images. It also includes reports or other GUI screens and review.

### Storing a clip:




Pressing the  hard key on the console will capture the moving images in scanning or cine review status. If the image is frozen or a non-image screen is displayed then a static image is stored.



The store starts with the press of the  hard key and continues for the configured length of the clip or until the clip store is interrupted. The length of the clip can be configured on the **Store/Print** page (See section 11.1.3 for details).

The following events can cause the clip store to stop:



- A second press of  key
- Display of a GUI screen or dialog
- Mode change
- Image parameters change
- Cine play pause



- Unfreeze the image

**NOTE:**

1. If the image is frozen or a non-image screen is displayed, a static image is always stored when pressing a store key.
2. In panorama mode, a static image is always stored when pressing a store key.

## 9.2 Reviewing Images

If Static or Clip images have been stored for the current exam then they can be reviewed by pressing the **<Review>** hard key on the console. The review touch screen is shown as the figure below.

**NOTE:** If nothing has been stored in the current exam then the **<Review>** hard key will invoke the Patient Database function (see the next section).

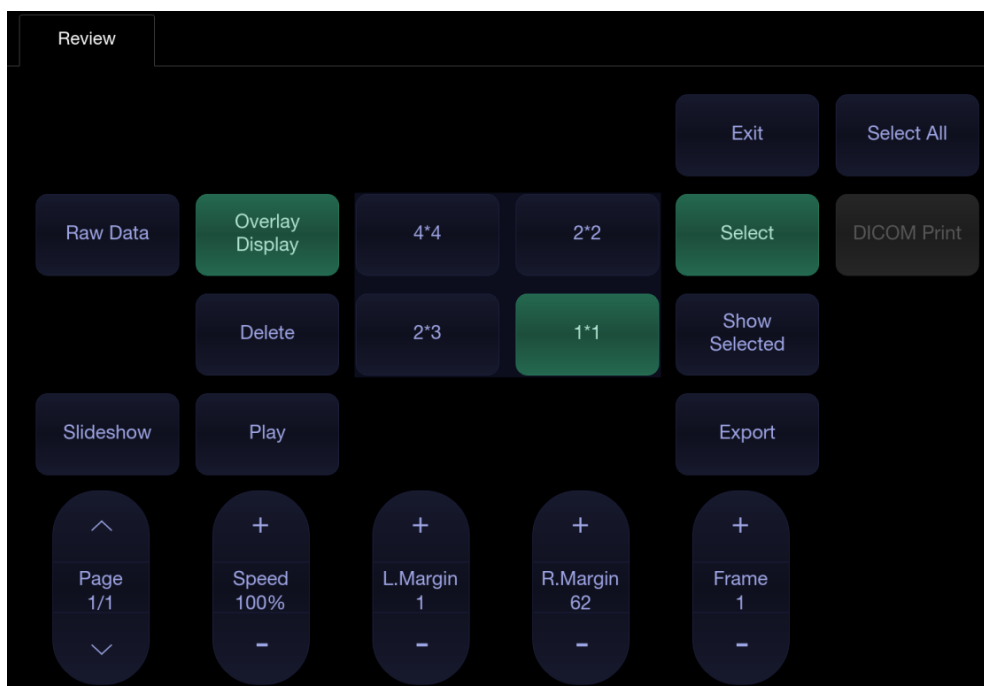


Figure 9-1 Review Touch Screen

No.	Button	Description
1.	Page	Change the display one page at a time.
2.	Speed	Change the playing speed of the highlighted clip.
3.	L.Margin	Change the left margin of a highlighted clip.
4.	R.Margin	Change the right margin of a highlighted clip.
5.	Frame	Scroll the paused clip frame by frame.
6.	Play	Plays/Stops the highlighted clip. This can also be done with the <b>&lt;Set&gt;</b> key on the control panel.
7.	Overlay Display	Show or hide overlay icons on thumbnail images
8.	Delete	Delete the selected image.

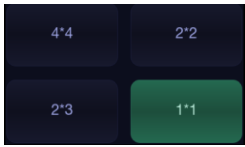
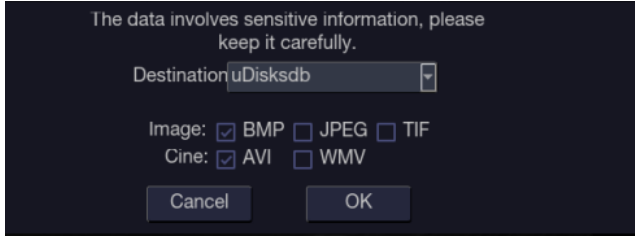
9.		Change the displayed layout: 4*4, 2*2, 1*1, 2*3
10.	Show Selected	Toggle between showing all images and only showing the selected images
11.	Select	Select an image.
12.	Select All	Select all the images in the current exam.
13.	Slideshow	Play all the images as a slideshow.
14.	Export	<p>Export selected images to USB disk. Plug in a USB disk, select an image, press this button and the following confirmation dialog pop-up:</p>  <p>Select the export path from destination drop list menu and click OK to confirm.</p>
15.	DICOM Print	Print the currently displayed images via the DICOM printer that connects to a DICOM server. Refer to Section 11.2.2 for details on configuring DICOM print.
16.	To Demo	Add the selected images to the "Demo" exam. It is only available when a "Demo" exam is imported.
17.	Raw Data	Load the raw data of the selected image or clip for post-processing. Use controls on the console or on the touch screen to do post-processing operations, such as imaging optimization, measurement, annotation, etc.
18.	Exit	Exit Review function

Table 9-1 Review Touch Screen Controls

### 9.3 Exam Database

The Exam Database provides a list of recently performed studies. It can be accessed by pressing the <Review> hard key on the console when there is no active exam.

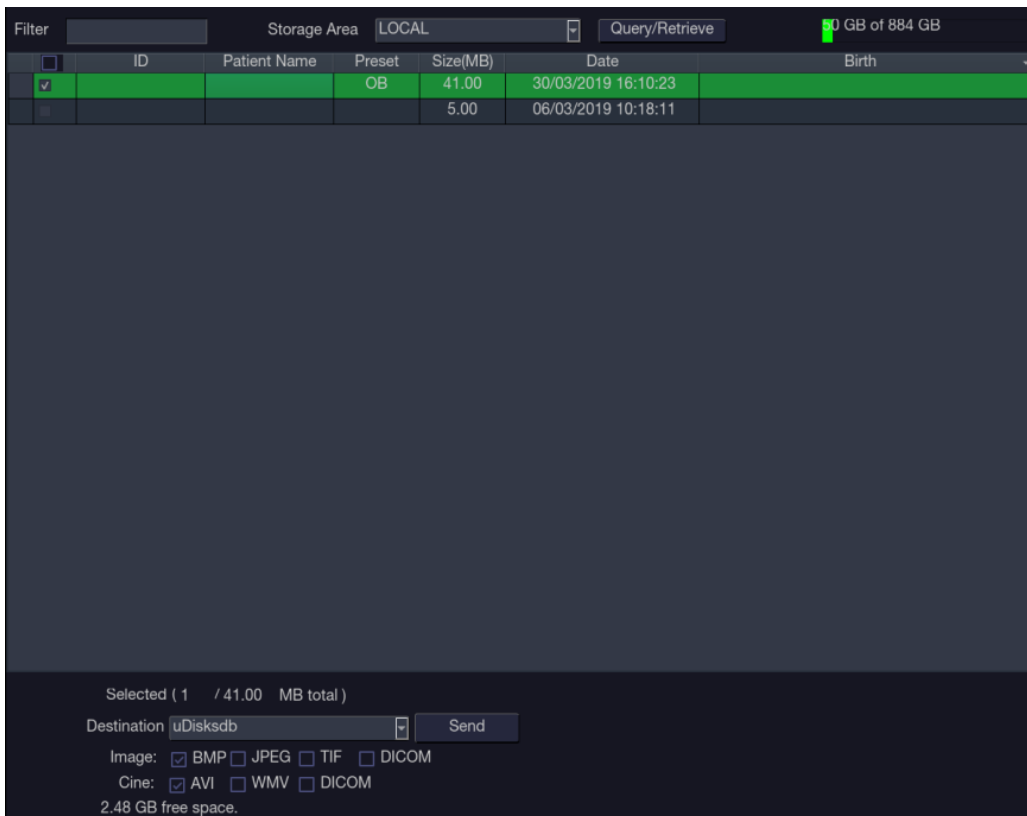


Figure 9-2 Exam Database Main Screen

The main part of the display shows a list of studies. Clicking on the header of a field will sort the list by that field. Fields can be displayed or hidden. If Password Protection is enabled, admin can view and operate all the studies, operators can only view and operate the studies they created.

**Filter:** The database filter field at the top-left of the screen provides a powerful tool to find the study of interest. It filters the list based on whatever text is typed in this field. The filter applies to all fields. For example, typing “Ab” into the filter will show exams that either have that text in either the patient name or in the Exam preset. By default the filter is set to blank, so the default list shows all exams.

**Storage Area:** There is a database storage area field at the top-right of the screen. User can select to review the studies in local or USB storage, and also can send the studies from local to USB or from USB to local. Select the required studies and click Send to complete. When sending the studies from USB to local, only images in DCOM format can be sent.

**Storage Size:** There is a box displaying current disk usage. It contains text with the current usage and is filled with a solid color to the extent that the current capacity is used. The text shows “<current usage> of <total capacity>”. The units are “Mb” for values less than 1 Gb, and “Gb” for anything larger. The solid color fill is green when usage is less than 75% of capacity, yellow for usage between 75% and 95%, and red when disk usage is above 95%.

**Destination:** The location where the highlighted exam(s) shall be exported, including:

- Available DICOM server location(s).
- Available FTP server location(s).
- Any inserted USB disk or DVD drive.

**Export Format:** This location displays export format for static images and clips. BMP, JPEG, TIF and DICOM formats are available for static images. AVI, WMV and DICOM formats are available for clips.

**Send/Burn:** Pressing this will send/burn the highlighted exam(s) to the destination. This button is available when one or more exams are selected.

➤ **Working with one study:**

A study is selected by clicking on it. When a study is selected thumbnail images from that study are shown on the right side of the screen. Operations such as editing report, reviewing, deleting and restarting of the selected study can be accessed on the touch screen.

A study can also be send to a network server, saved to a USB device or DVD drive, or deleted. If the study has been copied to either a server or to a USB device or DVD drive a small disk icon appears next to it, indicating that it has been saved.

**CAUTION:**

- Studies stored on the system hard drive should be archived regularly. The system is not intended for long term storage of patient information. Confirm successful archiving before deleting a study from the hard drive.

➤ **Working with multiple studies:**

Multiple studies can be selected by clicking the small box at the left of each listed study. Multiple studies can be stored to a network server, saved to a USB device or DVD drive, or deleted. Only one study can be reviewed at a time.

**Query/Retrieve:**

Pressing this will open the Query/Retrieve page, as shown below, where you can enter key words and query prior exams from the configured DICOM Server. How to configure the DICOM server, please see section 11.2.2.

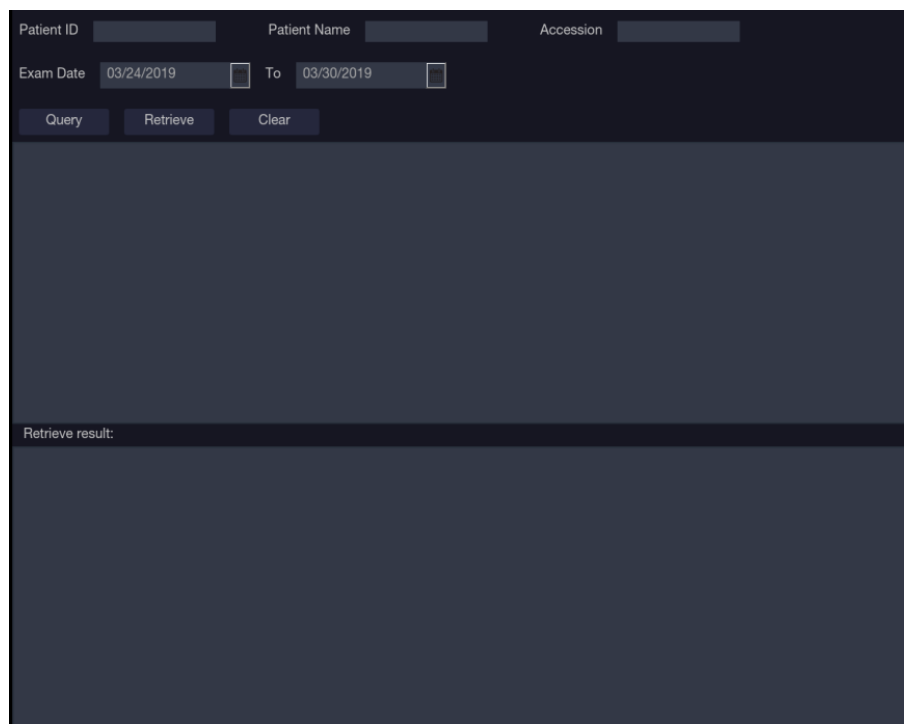


Figure 9-3 Query/Retrieve Page

- **Patient ID, Patient Name, Accession:** enter the key words for query.
- **Exam Date:** enter the date range.
- **Query:** press to start the query, and all the queried exams will be displayed in the box below.
- **Retrieve:** select one queried exam and press **Retrieve** to download it from the DICOM server to the **Retrieve result** box.
- **Clear:** clear all the queried and retrieved results.

## 9.4 Archiving Studies

All Clips and Static images stored on the system are stored internally in DICOM format. They can be archived to other storage device for long-term storage in multiple formats as described below.

- The study can be sent to a DICOM server.
- The study can be send to a FTP server.
- The study can be saved to a USB or DVD.

### ***Sending a study to DICOM server:***

There are three ways to send a study to a DICOM server. See Section 11.2.2 for details on configuring a DICOM server and choosing one of the following options.

1. From the exam database screen, you can select a study or multi-studies and send it to a configured server.
2. You can configure the system to automatically send the study at the end of the exam. With this option the study is sent in the background while you continue to use the system for the next exam.
3. You can configure the system to automatically send each image and clip as it is stored. This has the advantage that the images and clips are available on the server sooner. Note that if you have it configured this way you can still delete stored images and clips on the system, but that will not delete them on the server if they have already been sent.

### ***Sending a study to FTP Server***

Please see section 11.2.3 for details on configuring a FTP server. Once an FTP server is configured the exam can be sent to the server from the exam database screen. Select the exam(s) from the list shown, and select the FTP server from the list of currently configured destinations.

### ***Saving a study to USB or DVD***

If a USB flash drive is plugged in or a DVD disk is put in then studies can be archived to them. Plug the USB flash drive into a USB port or put one DVD disk into the DVD drive prior to invoking the patient database screen, select the exam(s) from the list shown, and select the device from the list of currently configured destinations.

## 9.5 Structured Report

Structured Reports are supported for OB, Gynecology, Cardiac and Vascular exams on this system. They can only be sent to a DICOM server together with images after the function of sending structured report being enabled in DICOM setup page (see Section 11.2.2 for detail).

### ***Sending structured reports to a DICOM server:***

There are two ways to send structured reports to a DICOM server.

- From the exam database screen, select the exam that has structured report and image, select a configured server from the list of available destinations and send it manually. For this way, you should first go to DICOM setup page and select "Transfer on demand" as the DICOM store way.
- Go to DICOM setup page and select "Auto-transfer when End Exam" as the DICOM store way. The system will automatically send the structured report at the end of the exam.

# 10 Presets

## 10.1 Preset Organization

The Presets are divided into two levels: the Exam Presets and Application Presets.

**Exam Preset:** Each transducer has its own set of Exam Presets. Each Exam Preset contains:

- The image parameters that optimize its transducer for an intended use.
- The list of data fields displayed on the patient demographic page.
- Pointers to Application Presets for Comments, Measurements, and Body Marks.

**Application Preset:** The Application Presets are independent from the transducer. Application Presets are used to select Comments, Measurements and Body Marks. Since they are independent from the transducer, several Exam Presets can use the same Application Preset.

Figure 10-1 shows an example of how Transducers, Exam Presets, and Application Presets are related. For simplicity, this shows just a few of the items that are on the real system. In this example the C5-2Q and the E8-4Q both have an OB Exam Preset. The C5-2Q OB Exam Preset optimizes the C5-2Q imaging for OB while the E8-4Q OB Exam Preset optimizes the E8-4Q for the same use. The parameters used for each transducer can be different, and changing one Exam preset does not change the other.

However, both OB Exam Presets point to the same OB Measurement Preset as the Application Preset. This means you can, for example, just configure OB measurements once, and both the C5-2Q and E8-4Q will have updated OB measurements.

This example just shows a single kind of Application Preset. The system actually has separate Application presets for Measurements, Comments, and Body marks. The same principle applies to each of these: application presets can be shared across exam presets and transducers.

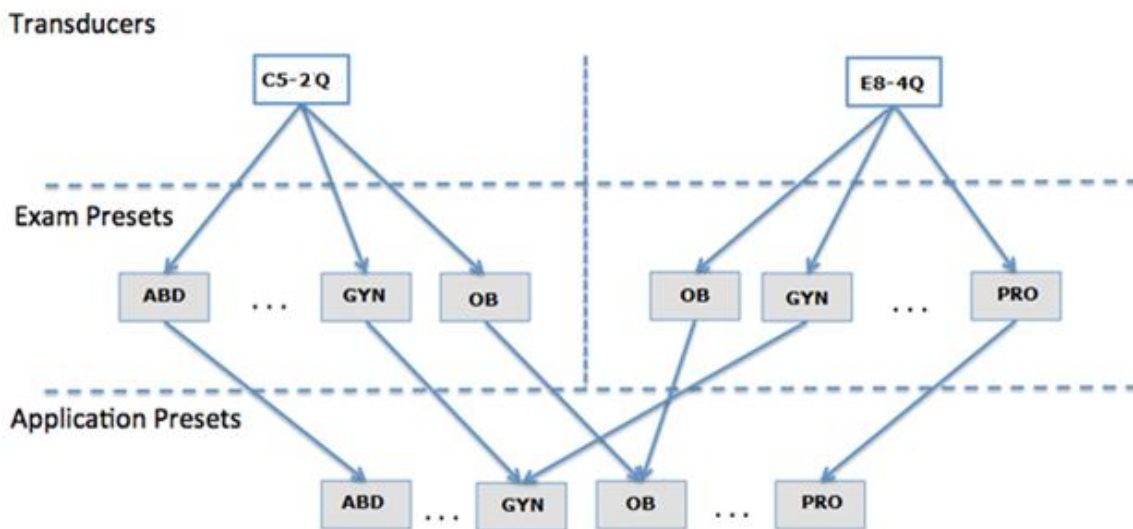


Figure 10-1 Preset Organization

## 10.2 Selecting a Preset

There are two ways to select a preset

**The Preset Function:** The preset function is invoked by pressing the **<Transducer>** key on the console. See figure 10-2 for an example Transducer touch screen. The currently active transducer is shown at the top of the touch screen. Below it are all the presets associated with that transducer. Pressing any preset button selects that preset, recalling its parameters for system use.

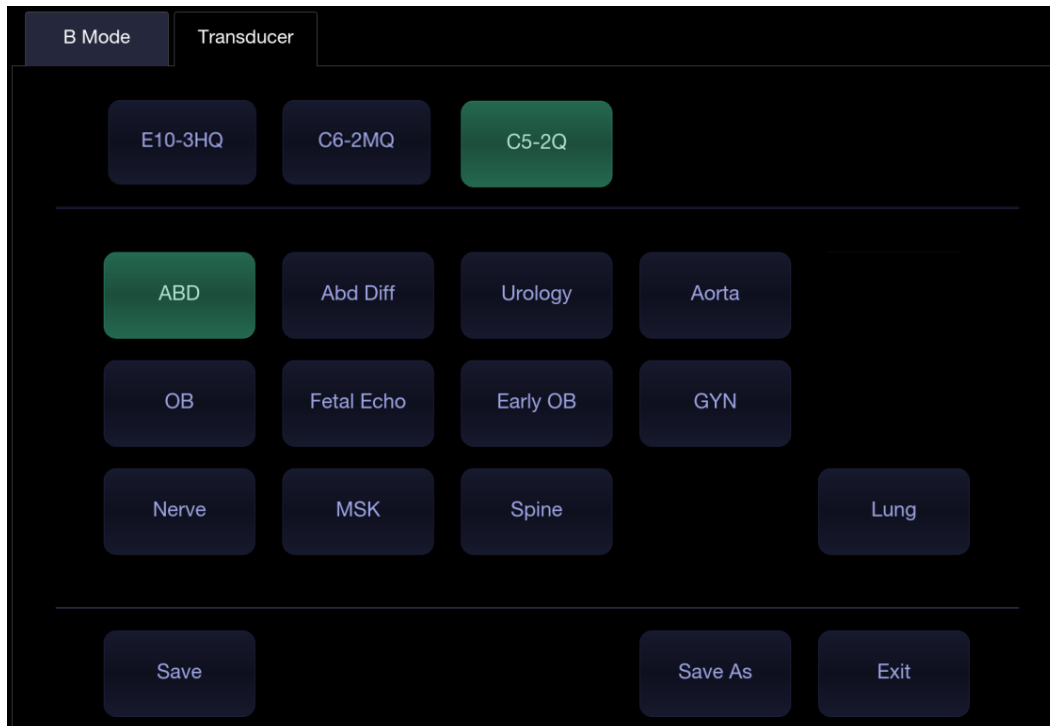


Figure 10-2 Example Preset Screen

**The Patient Page:** An exam preset can also be selected from the patient page, typically at the beginning of an exam. A drop-down list of presets associated with the current transducer is shown near the top of the screen. Select from that drop down to change the preset. This will also change the demographic fields that are displayed.

## 10.3 Storing and Editing a Preset

There are two ways to store or modify an exam preset: Snapshot and Editing.

### Snapshot:

- Select the exam preset you want to modify or use as the basis for a new preset.
- Make any changes you want to system settings using the standard imaging UI.
- Press the **<Transducer>** key on the console.
- Press the **Save** button on the touch screen to update the current exam preset with the new setting.
- Press the **Save As** button to create a new preset and rename the preset.

### Editing:

You can directly view and change the settings for any preset using the Set-up function.

- Press the **Utilities** key on the touch screen.
- Press the **Set up** button on the touch screen to invoke setup, as shown below:

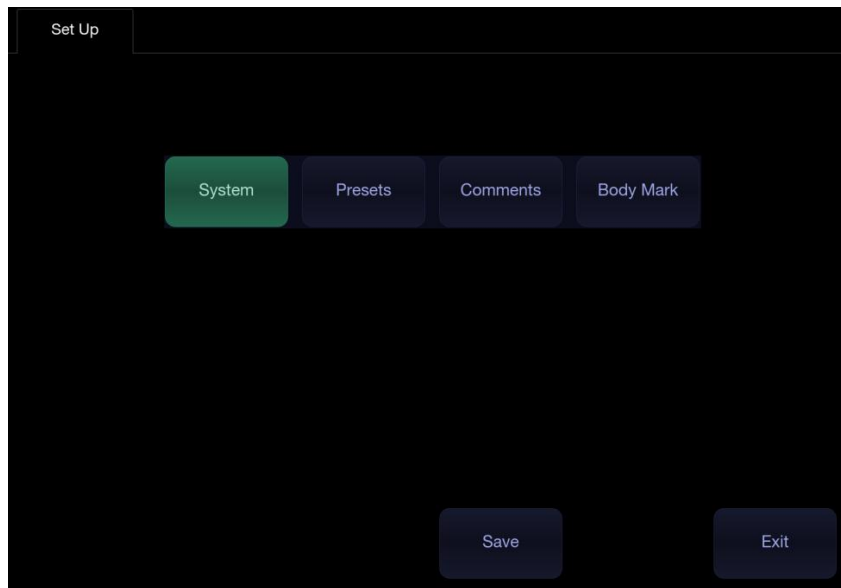


Figure 10-3 Top level Touch Screen for the Setup Function

- Press **System** to edit overall system settings unrelated to presets. See section 11 for details.
- Press **Presets** to do any of the following:
  - Edit the imaging parameters of an exam preset.
  - Configure the demographic fields that appear for that preset
  - Configure which Comment, Measure or Body Marker presets are associated with each exam preset.
- Press **Comments** to configure the pre-defined text of each comment preset.
- Press **Body Mark** to configure which body marker graphics appear with each Body Mark preset.

### 10.3.1. Exam Preset

Press **Presets** to display the Exam Preset page, as shown below:

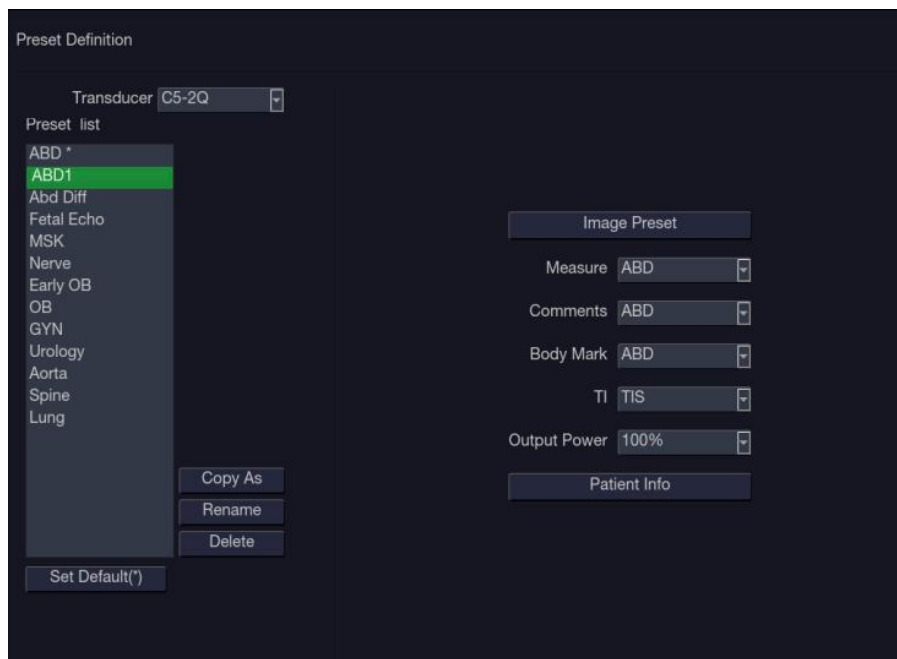


Figure 10-4 The Preset Definition Page



**Transducer:** Select one transducer from the list to configure its exam presets.

**Preset List:** Select one exam preset to configure its associated Image, Comment, Measure, Body Mark or Patient info settings.

**Image Preset:** Open the Image Preset page, as shown below, for configuring the imaging parameters for each imaging mode.



Figure 10-5 Example Set-up Screen for Imaging Parameters

- **Transducer** and **Exam Preset:** There are drop-downs at the top of the screen for selecting the transducer and Exam Preset you want to edit. Each transducer has its own set of exam presets, and these two drop-downs let you select which exam preset, on which transducer, you want to edit.
- **Image Modes:** The next row of controls show tabs for each imaging mode. These let you select which imaging mode you want to edit for the current exam preset. The example shows the B-mode tab selected.
 

The image mode is divided into two sections. Parameters that have one value for each preset are shown on the left. Parameters that are associated with Image Types are shown on the right.
- **Image Type:** Each imaging mode has a set of image types. For example in B-mode the types are Detail, General, and Penetration. While imaging, the image type lets you quickly change the aesthetic look of the image without changing settings like depth or invert status. The right side of the preset set-up screen shows a tab for each image look. The parameters shown below those tabs let you customize that image type for the current preset.

**Measure:** Select one of the pre-defined application measurement packages to be the default measure preset for the selected exam preset.

**Comments:** Select one of the pre-defined comment presets to be the default comment preset for the selected exam preset.

**Body Mark:** Select one of the pre-defined body mark presets to be the default body mark preset for the selected exam preset.

**Tf:** Select the TIB, TIS or TIC to display on main screen.

**Output Power:** Set the default acoustic output power of the selected exam preset.

**Patient Info:** Open the patient information configuration page. This page allows you to configure which demographic fields are shown in the Patient Information Page for the selected exam preset. Or, you can select other exam preset you want to configure on the left side of the screen and configure it directly on this page. Click the check box on any field you want to display.

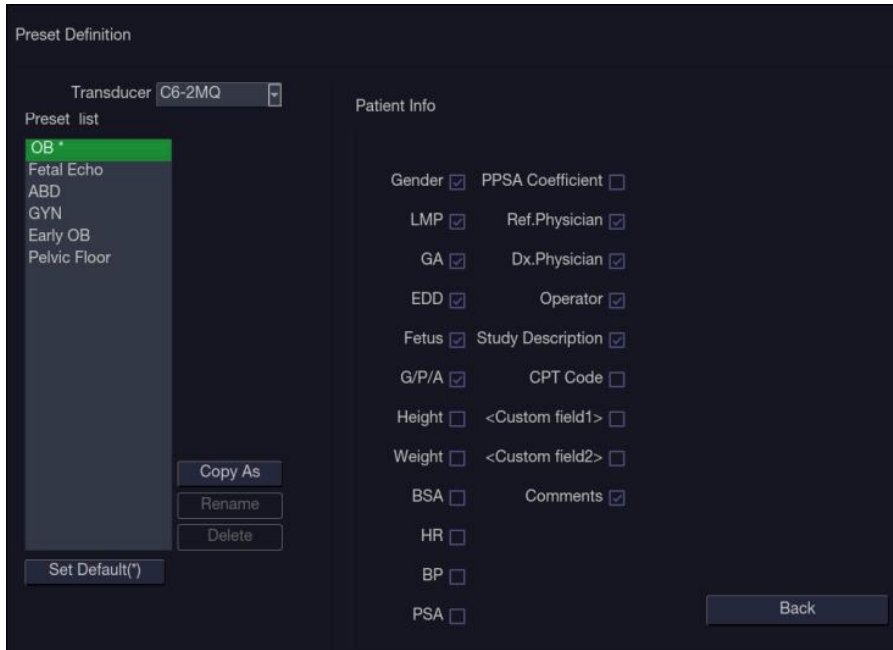


Figure 10-6 Example Patient Information Configuration Page

**Set Default:** Set the selected exam preset as the default exam preset of the transducer. The default exam preset will be marked with "\*".

**Copy As and Rename:** Copy the selected exam preset as a new preset and then rename it.

**Delete:** Delete the copied exam preset.

### 10.3.2. Comment Preset

Press **Comments** to display the Comment Preset page, as shown below, where you can add or edit the comment texts of each Comment preset.

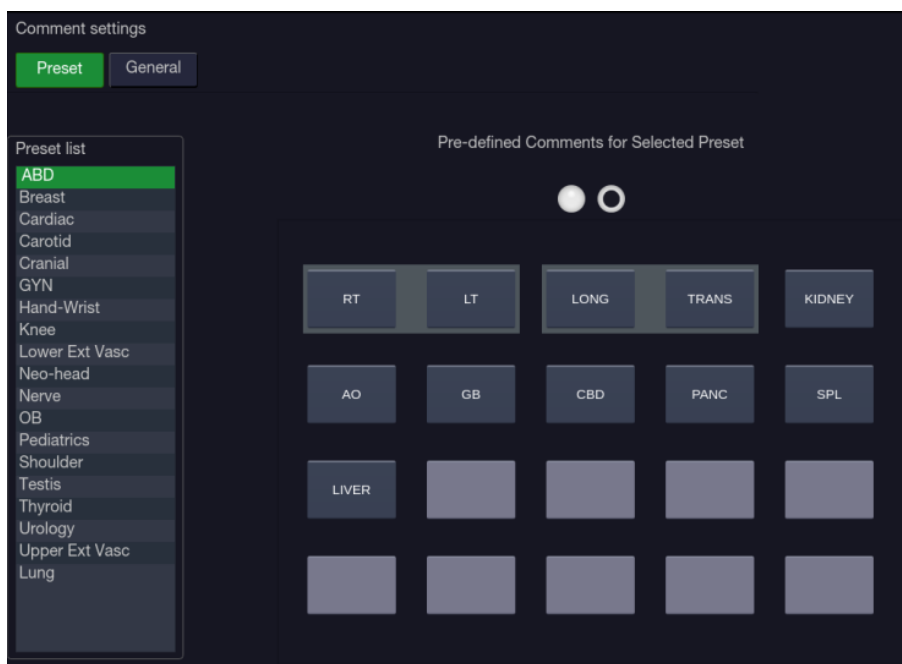


Figure 10-7 Comment Preset Screen

**Editing Comment Preset:**

Select a comment preset from the preset list on the left side of the screen, and then you can do the followings to edit the comment texts for the selected preset.

**➤ Adding a new Comment:**

1. Move the cursor to a blank field and press <**Set**> key.
2. Enter a new comment through keyboard.

**➤ Editing an Exist Comment in Comment Preset:**

1. Move the cursor to a comment and press <**Set**> key.
2. Edit the selected comment through keyboard.

**➤ Deleting an Exist Comment in Comment Preset:**

1. Move the cursor to a comment and press <**Set**> key.
2. Press **Delete** on touch screen to delete the selected comment.

**Creating a Group of Comments:**

1. Move the cursor over the intended comment then press-and-hold the <**Set**> key. The selected comment will pop-up.
2. Drag the selected comment on top of an adjacent comment or insert it into an adjacent group, then press <**Set**> key. The selected comments are joined as one group.

**Moving out a Comment from a Comment Group:**

1. Move the cursor over the intended comment then press-and-hold the <**Set**> key, the selected comment will pop up.
2. Drag the selected comment to a blank field and press the <**Set**> key. The selected comment is removed from the group. The rest of the comments in the group will be re-ordered. If there is only one comment in the group, then the group is disbanded.

**General Settings:**

- **Auto-erase comments when the image is unfrozen:** If this option is enabled, the comments will be erased when the image is unfrozen, otherwise the comments will only be erased on demand or at the start of a new exam.
- **Suppress Comment on Unfreeze:** If this option is enabled the Comment function goes away when the system is unfrozen, and comes back again with the next freeze. Manually exiting the function causes it to remain inactive until manually activated.

**10.3.3. Body Mark Preset**

Press **Body Mark** to display the Body Mark Preset page, as shown below, where you can configure which body mark graphics appear with each Body Mark preset.

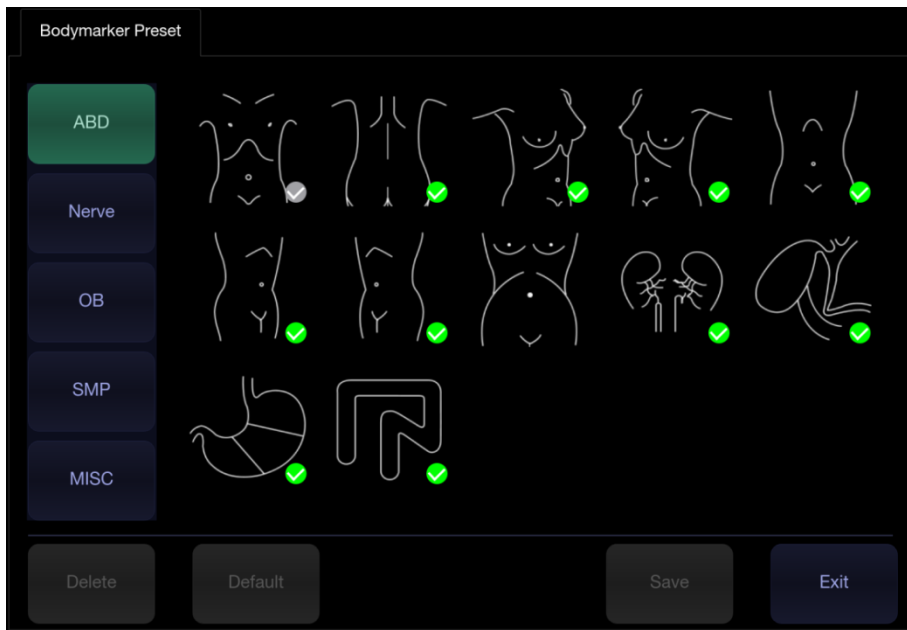


Figure 10-8 Body Mark Preset Touch Screen

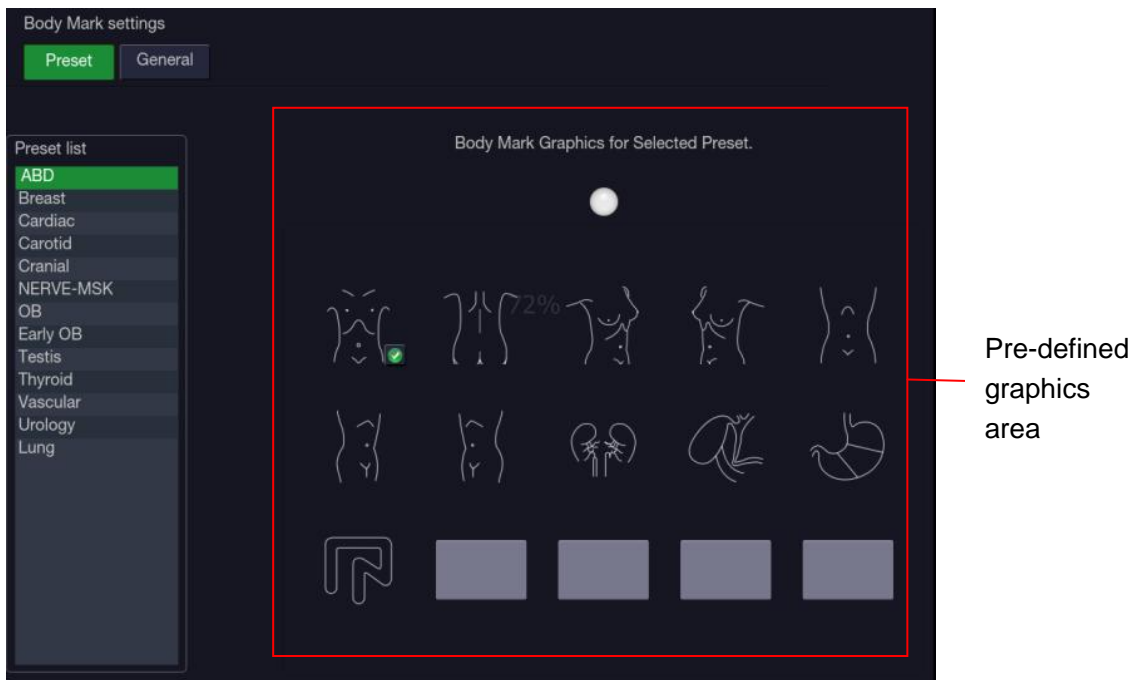


Figure 10-9 Body Mark Preset Main Screen

**Editing Body Mark Preset:**

Select an Body Mark preset from the preset list on the left side of the screen, and then you can do the followings to edit the body mark preset for the selected preset.

➤ **Adding a Body Mark to a Preset:**

The touch screen provides Body Mark Library. Select one domain of Body Mark from the left side of the touch screen, for example ABD, and its body mark graphics are displayed on the touch screen. Press a body mark graphic on touch screen to switch it as checked or not, and then the body mark graphic is enabled or disabled to current preset. When a Body Mark graphic is added to current preset, it is marked with a green check mark in the Body Mark Library. When more than one page of Body Mark graphics are added to current preset, the system will create another new page, indicating by dots in pre-defined graphics area. Clicking the dots switches the page.

➤ **Deleting a Body Mark from a Preset:**

Move the cursor to a Body Mark graphic in pre-defined graphics area and press **<Set>** key. Press the **Delete** button on the touch screen to delete it.

Or, press the added Body Mark graphic on the touch screen again to delete it from the selected preset.

➤ **Moving a Body Mark in Pre-Defined Graphics Area:**

1. Move the cursor over a Body Mark graphic in pre-defined graphics area, then press-and-hold the **<Set>** key, the selected Body Mark graphic will pop up
2. Move the trackball to a desired position and press the **<Set>** key to confirm the moving. To move it to another page, move the trackball over page up or down icons.

➤ **Setting a Default Body Mark for a Preset:**

Select a Body Mark graphic from pre-defined graphics area and press **Default**, the Body Mark graphic is set as a default Body Mark to the selected preset.

The default Body Mark can not be deleted from a preset until another Body Mark is selected as a default one.

**General Settings:**

- **Auto-erase Body Mark when the image is unfrozen:** If this option is enabled, the Body Mark will be erased when the image is unfrozen, otherwise the Body Mark will only be erased on demand or at the start of a new exam.
- **Suppress Body Mark on Unfreeze:** If this option is enabled the Body Mark function goes away when the system is unfrozen, and comes back again with the next freeze. Manually exiting the function causes it to remain inactive until manually activated.

## 10.4 Measure Presets

Press **Utilities->Measure** on the touch screen to display the Measure Preset page.

### 10.4.1. General Set-up

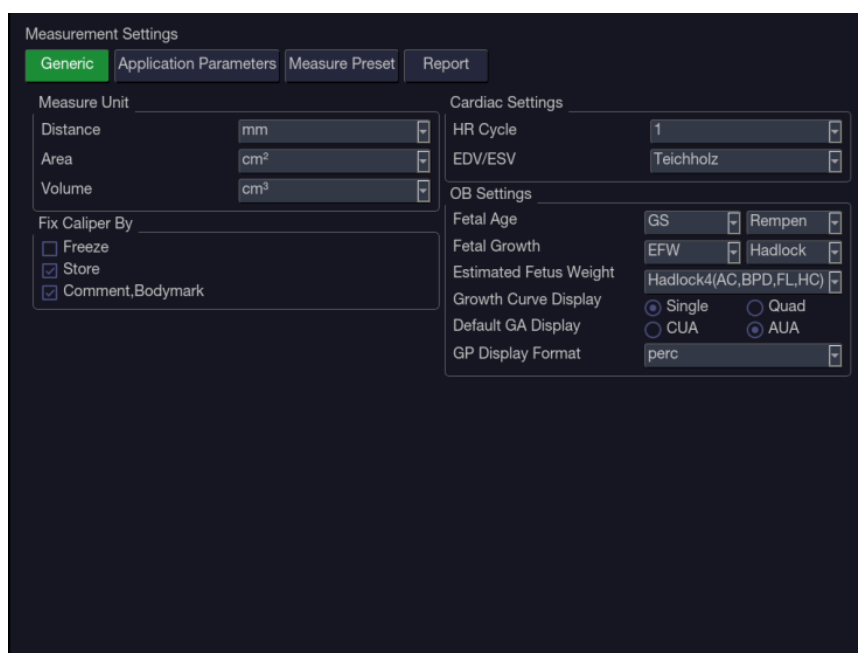


Figure 10-10 General Set-up Screen

- **Unit Settings**

The system supports following unit settings:

- **Distance:** Set the default unit of distance measurement. "mm" and "cm" are available.
- **Area:** Set the default unit of area measurement. "mm<sup>2</sup>" and "cm<sup>2</sup>" are available.
- **Volume:** Set the default unit of volume measurement. "mm<sup>3</sup>" and "cm<sup>3</sup>" are available.

- **Cardiac Settings**

The system supports following Cardiac measurement settings:

- **EDV/ESV:** set the author of the formula that is used in EDV/ESV calculation. There are three options: Teichholz, Gibson and Cube.
- **HR Cycle:** set the number of heartbeats that are assumed in the HR or FHR measurement calculation. Range: 1-8.

- **Fix Caliper By**

Select the way for fixing caliper(completing measurements). Available options include Freeze, Store, Comment and Body Mark.

- **OB Settings**

The system supports the following OB measurement settings:

- **Fetal Age:** set equation for measurements which are used for calculating fetal age.
- **Fetal Growth:** set equation for measurements which are used for calculating fetal growth.
- **Estimated Fetus Weight:** select an equation for the Estimated Fetus Weight calculation.
- **Growth Curves Display:** set single or quad curves as the default display format for the Growth Curves.
- **Default GA display:** set the CUA (Composite Ultrasound Age) or AUA (Average Ultrasound Age) as a default result displayed in the worksheet.

## 10.4.2. Application Parameter

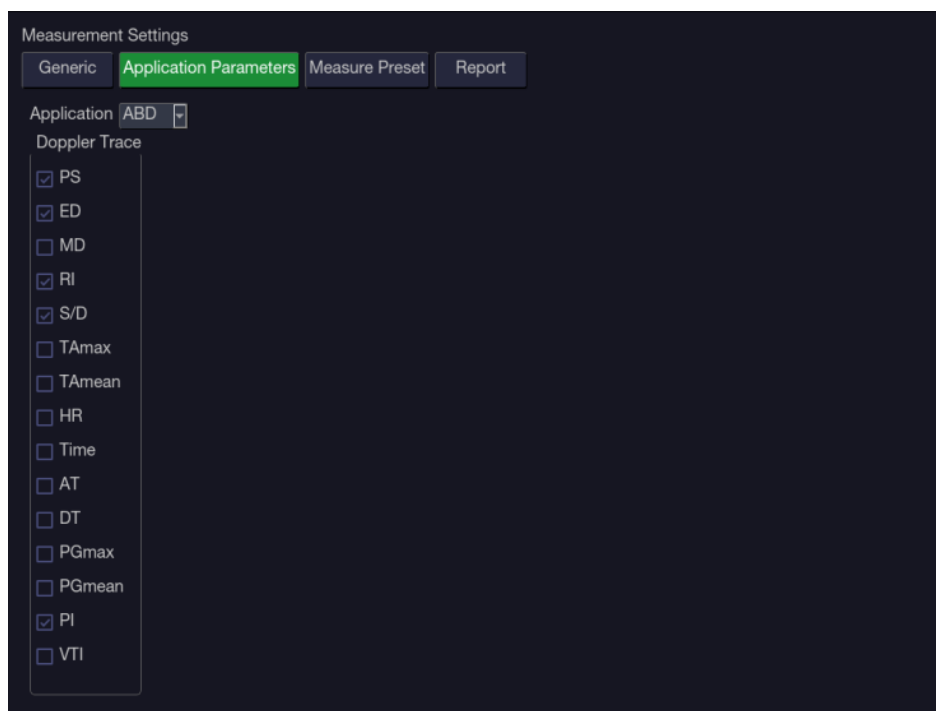


Figure 10-11 Application Parameter Set-up Screen

On the **Application Parameter** page, you can configure the default measurement results of Doppler trace measurement for each exam application. Select one clinic application in the **Application** drop-down list, for example ABD, and then tick the measurement result items in the list below. When you perform Doppler trace measurement, the system will display all the ticked result items by default.

### 10.4.3. Measure Presets

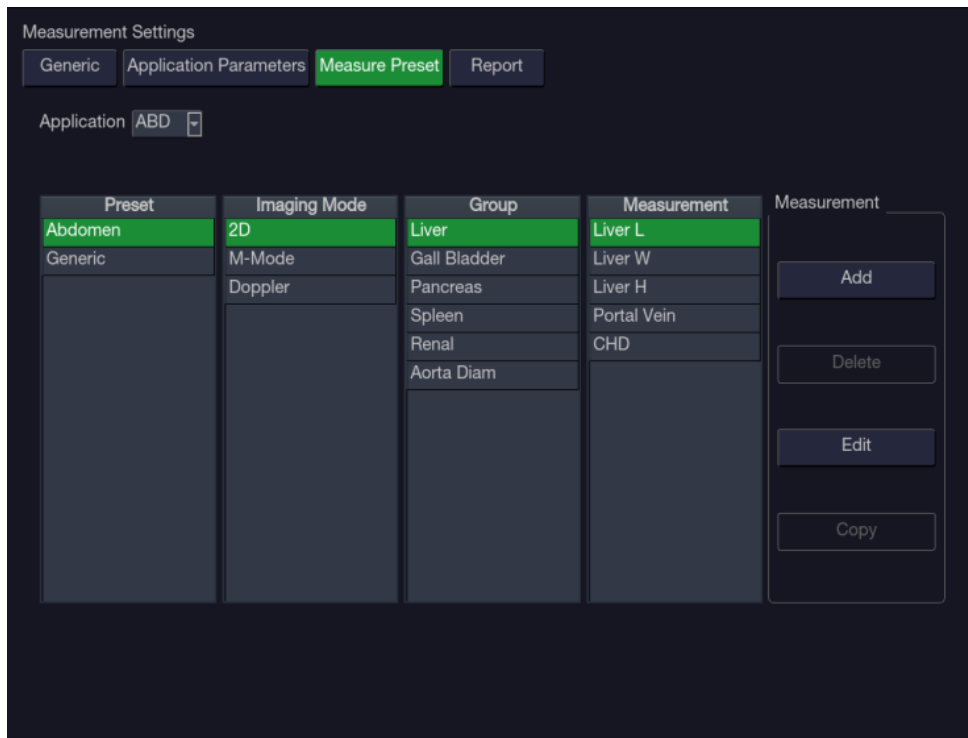


Figure 10-12 Measure Preset Set-up Screen

On the Measure Preset page, you can configure the measurements for each exam preset in each imaging mode. Follow the steps below:

1. Select exam application

Select an exam application, for example ABD, in the **Application** drop-down list.

2. Select exam preset

Select an exam preset in the **Preset** list, for example Abdomen.

3. Select imaging mode

Select an imaging mode in the **Imaging Mode** list, for example 2D.

4. Select measurements

In the **Group** list, select a measurement group, and all the measurement items included in this group are displayed in the **Measurement** list. Now the following operations are allowed through the controls on the right side of the screen:

- **Add**: Add measurement items to the selected measurement group. Clicking on **Add** button will bring you a menu for selecting other measurement items.
- **Edit**: Set the default measurement tool and measurement result for the select measurement item.

Note:

Cancel and Copy operation is not available for this release.

### 10.4.4. Report Set-up

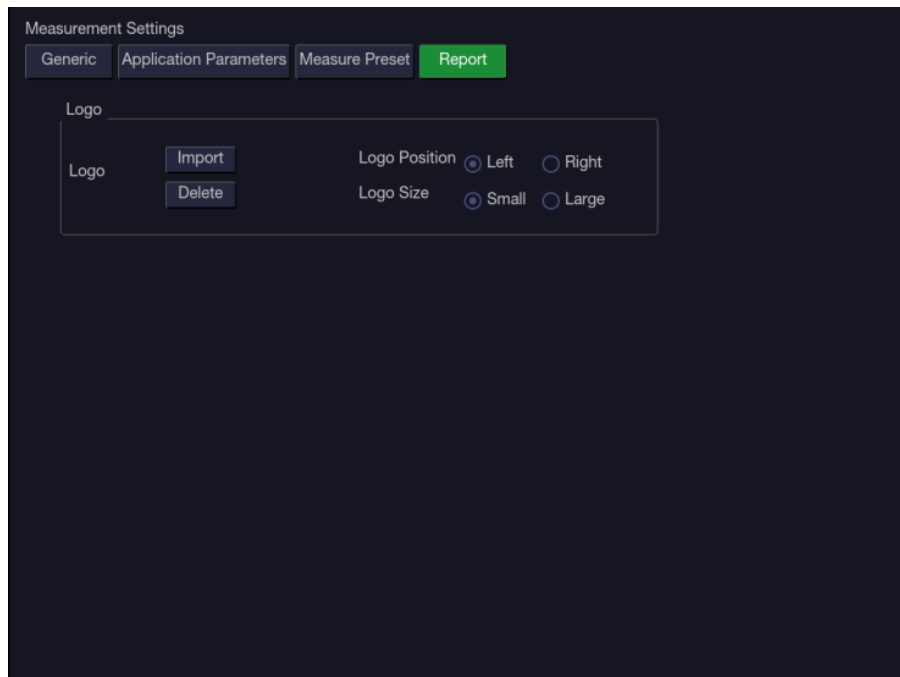


Figure 10-13 Report Set-up Screen

The system supports a user-defined report header by importing a logo and setting the logo's position and size.

Report logo settings are as follows:

- **Import:** import a bmp format logo from USB disk.
- **Delete:** delete the imported logo.
- **Logo Position:** set the logo position to locating at the left or right side of report header.
- **Logo Size:** set the logo size to Small or Large.



# 11 Utilities

Press **Utilities** key on the touch screen to open **Utilities** screen. The **Utilities** screen provides access to System setup, Presets, Measure presets, Connectivity, Maintenance, Screen adjust, etc. Each of these is described in separate sections.

## 11.1 System Set-up

System setup is used to configure parameters that are unrelated to presets. Generally, there is one value of each system setup parameter that is shared across all presets.

### Entering System Setup:

Press **Utilities**-> **Setup**-> **System** touch screen buttons to access system setup.

### Reloading Factory Default Settings:

1. Press "Restore Factory Settings" on the Set-up screen, you are prompted "Restore System Setting to factory default? This will erase all current system settings".
2. Press **Yes** to restore to factory default, and press **Cancel** to cancel.

### 11.1.1. General Set-up

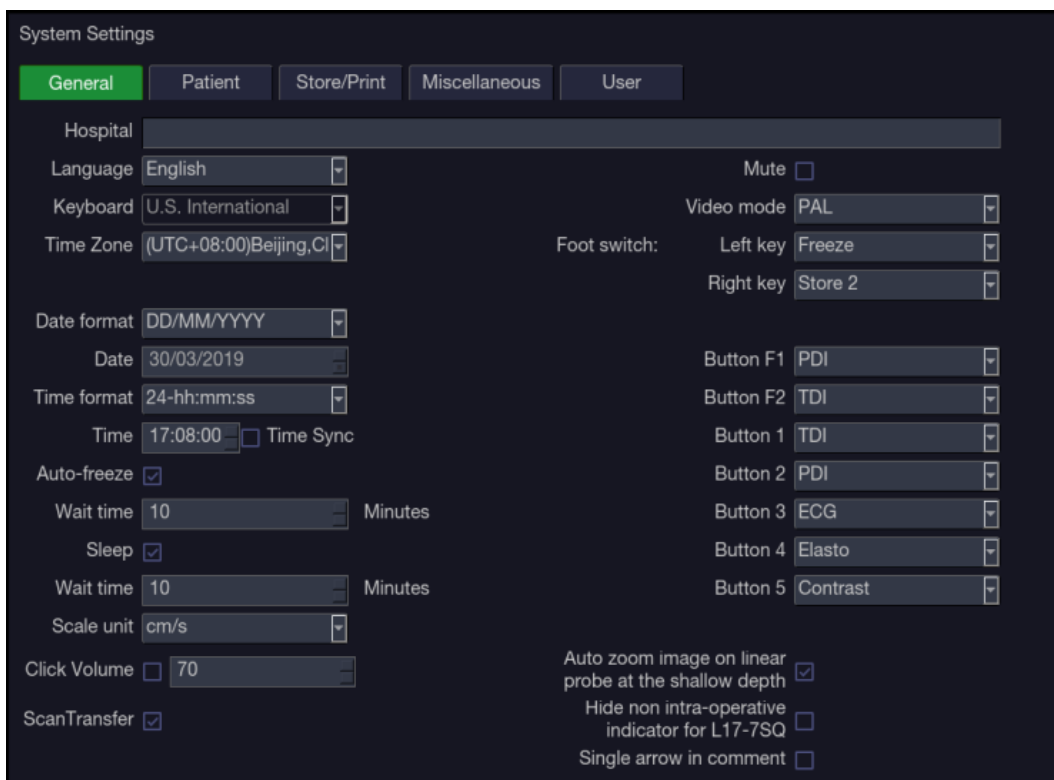


Figure 9-1 General Set-up Screen

Item	Options	Description
Hospital	Input freely	Set hospital name displayed on the top left of the screen and diagnosis report
Language	Chinese, English	Set the system language(new language is effective after reboot the system)
Keyboard	U.S International	Set the keyboard layout

Date Format	YYYY/MM/DD/ MM/DD/YYYY DD/MM/YYYY	Set the date format
Date	Set freely	Set the system date Note: If the license is invalidated because of changing the system date, please contact EDAN serviceman.
Time Format	12-AM/PM, 24-hh:mm:ss	Set the time format
Time	Set freely	Set the system time, format: H/M/S
Auto-Freeze& Waiting Time	√/× 1-999 min	Set whether to turn on auto-freeze function by default or not; and set the waiting time to perform auto-freeze
Sleep& Waiting time	√/× 1-999 min	Set whether to turn on system sleep function by default or not; and set the system waiting time to enter sleep mode
Button F1/F2	Needle PDI DPDI	Define the F1/F2 keys, select one of the pull-down options. The options that are available will depend on what functions are enabled on the system.
Scale Unit	cm/s, kHz	Set the velocity units of spectrum scale
Click Volume	√/× Volume level: 10-100	Set the volume of hard keys and onscreen keys.
Mute	√/×	Set the system volume.
Video Mode	PAL/NTSC	Set the output video mode, the selected video mode should be the same as that of the s-video printer, otherwise the printer can not work.
FootSwitch	Freeze/Store1/Store2/Print	Set a function for the left key or right key of FootSwitch. If the physical footswitch only has one button then the Left button selection applies.
Button 1 Button 2 Button 3 Button 4 Button 5	TDI PDI ECG Elasto Contrast	Set a function for the five shortcut keys on the left of the touch screen.
Auto zoom image at shallow depth on linear transducer	√/×	Set whether to zoom in the image automatically when adjusting image depth to shallow depth on linear transducer.

Hide non intra-operative indicator for L17-7SQ	√/x	Set whether to hide the hint of “non intra-operative” while using transducer L17-7SQ.
Single arrow in comment	√/x	Set whether to add only a single arrow at a time when adding comments on an image.

Table 11-1 General Set-up Description

### 11.1.2. Patient Set-up

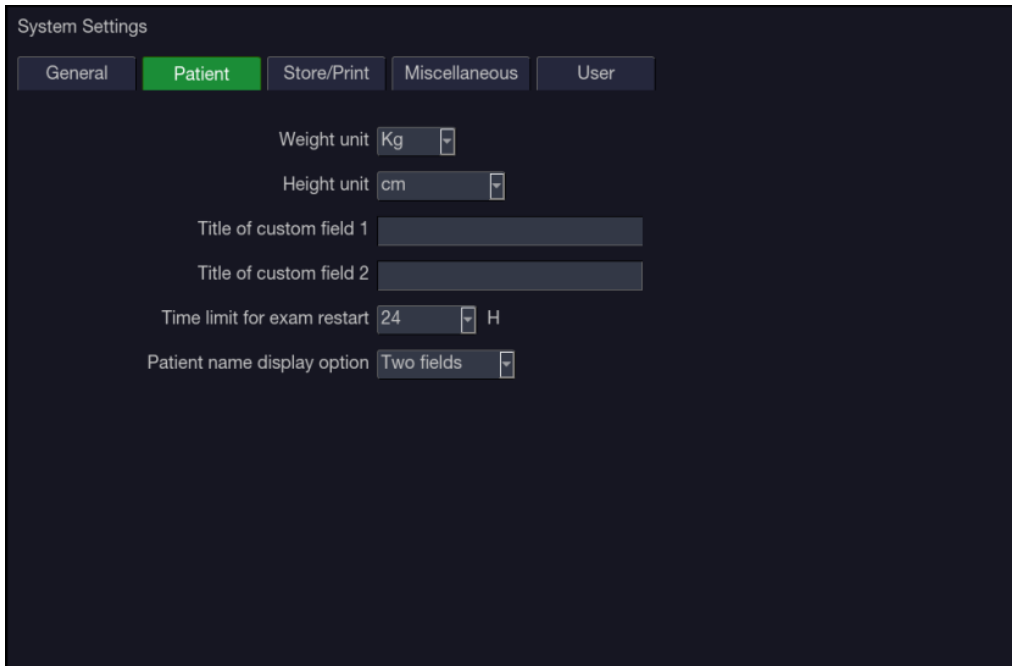


Figure 11-2 Patient Set-up Screen

<b>Item</b>	<b>Options</b>	<b>Description</b>
Weight Unit	kg, lbs	Set the weight unit of patients.
Height Unit	cm, ft/in	Set the height unit of patients.
Title of custom field 1/2	/	You can define two additional fields for data entry on the Patient Information screen.
Time Limit for Exam Restart	0/12h/24h/48h/72h	You can define the time limit for restarting exam. Only exams within the time limit can be restart. If 0 is selected, no exam can be restart.
Patient Name Display Option	One field/Two fields	You can define the patient name display format. The patient information page displays “Patient Name” for one field and displays “Last Name” and “First Name” for two fields.

Table 9-2 Patient Set-up Description

### 11.1.3. Store/Print Set-up

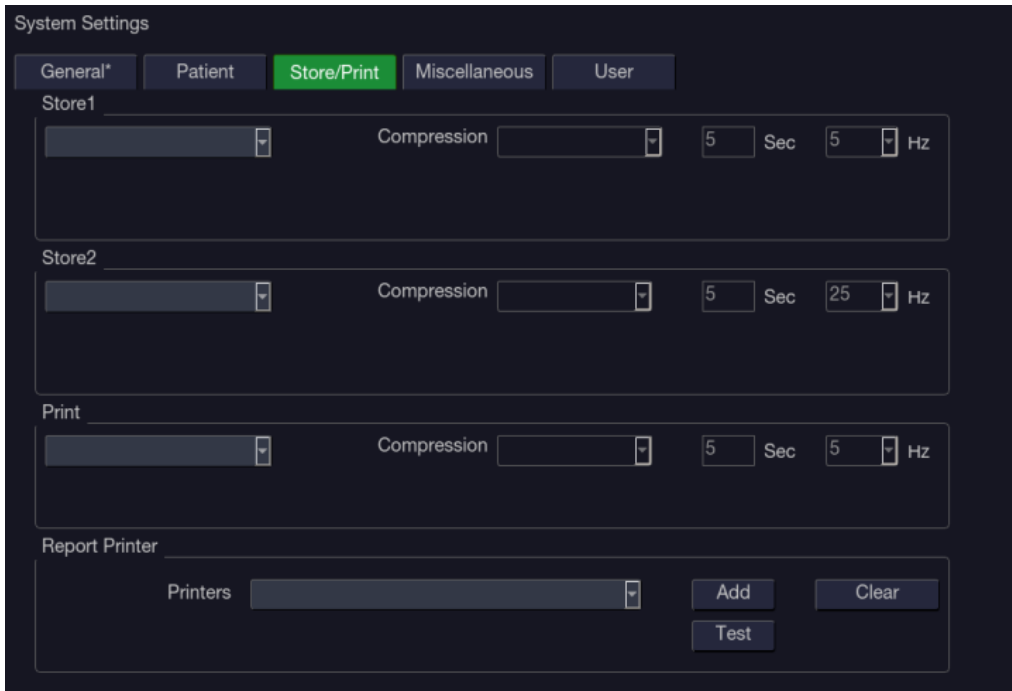


Figure 11-3 Store/Print Set-up Screen

<b>Item</b>	<b>Options</b>	<b>Description</b>
Store1/Store2/ Print	Store Image	Store static image to internal hard disk
	Store Clip	Store clip to internal hard disk
	SONY-UP-D25MD, SONY-UP-D898MD_X898MD	Connect the corresponding printer to print the current image.
Compression	Lossless/Low/Medium/High	Set the image compression type
Duration	≤10 seconds	Set the clip capture duration
Target Frame Rate	5/10/15/20/25 Hz	Set the clip capture frame rate
Report Printer	Printers	List up to six printer models that have been added to this system recently. If one of the six printers is connected to the system again, you can print directly.
	Add	Add a new printer to this system, and its printer model will be shown in printers list.
	Test	Test whether the printer is connected successfully.
	Clear	Clear all the printer settings.

Table 11-3 Store/Print Set-up Description

### 11.1.4. Miscellaneous Set-up

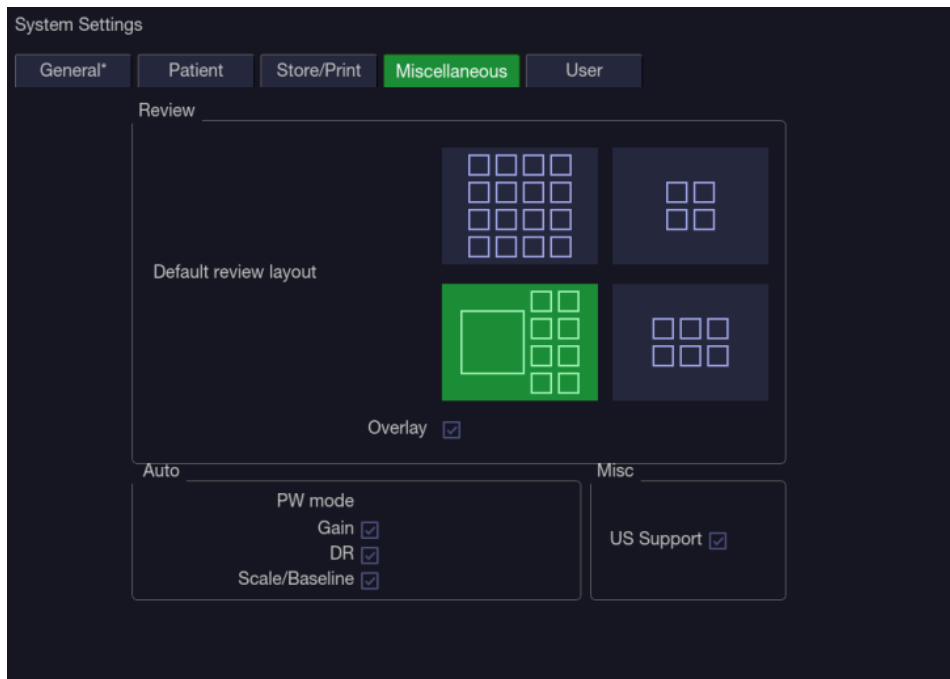


Figure 11-4 Miscellaneous Set-up Screen

<i>Item</i>	<i>Options</i>	<i>Description</i>	
Default review layout	4*4, 2*2, 1*1, 2*3	Set the default review layout.	
Overlay	√/x	Show or hide overlay icons on thumbnail images.	
PW mode	Gain	√/x	Optimize Gain or not when press Auto button on the control panel in PW mode.
	DR	√/x	Optimize Dynamic Range or not when press Auto button on the control panel in PW mode.
	Scale /Baseline	√/x	Optimize Scale/Baseline or not when press Auto button on the control panel in PW mode.
US Support	√/x	Set whether the server in USA or in China will be connected when using the Remote Support function. Checking US support will display a "Edan US Support" button on the touch screen providing the access to connecting the server in USA. Otherwise, a "Edan CN Support" button will be displayed providing the access to connecting the server in China. Contact EDAN Service for the instructions for using Remote Support function.  Warning: Remote Support is only a training and service tool. It is not intended for diagnosis.	

Table 11-4 Miscellaneous Set-up Information

### 11.1.5. User Set-up

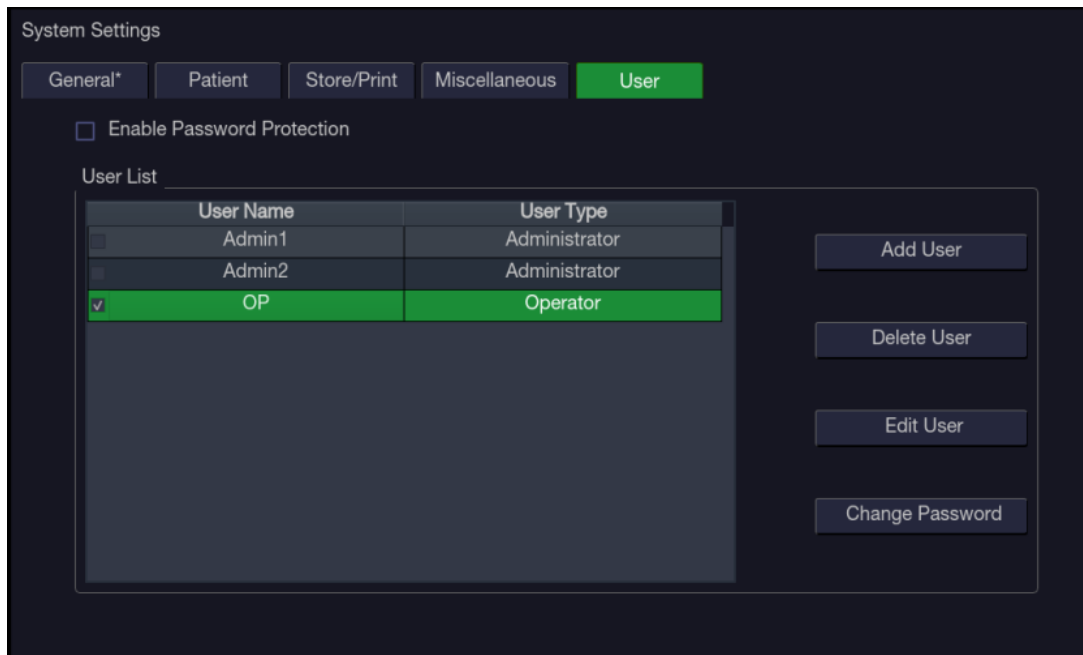


Figure 11-5 User Set-up Screen

Item	Options	Description
Enable Password Protection	√/×	Show or hide the login dialog when booting up the system. Password is required to enable password protection function.
User List	√/×	Show all users displaying user name and user type. Click the dialog before the user to select this user for edit operation

Table 11-5 User Set-up Information

User type includes Administrator and Operator.

- Administrator users have authority to enable/disable password protection, add/delete/edit users and can view all exams in the patient database. There are two pre-defined administrator users called Admin1 and Admin2.
- Operator users can only edit their own user information, change their own password, and view exams that they created.
- There’s one pre-defined operator user called Emergency for Emergency login without entering password. The exams created by Administrator and Operator can not be viewed through Emergency login.

There’s a couple of buttons for different user edit operation. It includes Add User, Delete User, Edit User, and Change Password.

- **Add User:** Click it to add user in the user list.
- **Change Password:** Click it to change the password of the users.
- **Delete User:** Click it to delete the highlighted user in user list.
- **Edit User:** Click it to modify the user information.

---

---

**Caution**

1. For security consideration, a password with high secure intensity is suggested for each user account, and the password should be changed periodically.
  2. Please keep your user name and password safe.
  3. Change the passwords of two pre-defined administrator users:Admin1 and Admin2 immediately when you get the ultrasound system.
  4. Always enable the function of user login with password protection.
- 
- 

## 11.2 Connectivity

### **Entering Connectivity Screen:**

Press **Utilities**-> **Connectivity** touch screen buttons to access Connectivity screens.

The Connectivity screens support configuration of network access and services. It is divided into 3 tabs:

- **TCP/IP:** Configures access to the network from the system.
- **DICOM:** Configures network DICOM services.
- **Network Store:** Configures non-DICOM storage to a network via FTP.

---

---

**WARNING**

1. Please build a secure network environment for your ultrasound system to protect the patient data being attacked during network transmissions.
  2. Patient data transmitted by the system is encrypted with AES algorithm.
  3. Please ensure the physical security of the network by trying the following measures:
    - a) Install IDS(Intrusion Defense System) and IPS(Intrusion Protection System) software in the network environment where your ultrasound systems are used.
    - b) Use a network that is isolated from the external environment by a firewall.
    - c) Use the WPA2 protocol for authentication and encryption of wireless network, and a password with high secure intensity is required.
    - d) Do not connect the ultrasound system and non-medical devices to a same network.
    - e) Set a login password with high secure intensity at your FTP server side. Keep the login user name and password of FTP server safe. The leak of user name and password may lead to patient information and data being disclosed.
  4. Anti-virus software is not installed on this device. Please take anti-virus measures in the network environment where your ultrasound systems are used.
  5. It is required to use Windows or IOS operating system for Service Engineers when doing customer service to reduce the risk of Linux virus transmission. Root permission is restricted to use on ultrasound system to avoid the risk of executing virus files.
- 
-

### 11.2.1. TCP/IP

This screen configures access to a network. Access can be either wired or wireless.

Figure 11-6 TCP/IP settings

#### **Wired Settings:**

The following settings apply when connecting a system to a wired network via the network port on the side of the system.

**Get Local IP:** Either Manually entered (Static) or DHCP. The correct setting will depend on how your DICOM network is administrated. If you are unsure, try DHCP first. Generally a Static IP is only needed if the target PACS system requires it. If it is needed, contact your network IT manager.

**IP Address, Subnet Mask, Gateway, DNS:** These settings determine how the system communicates with your network. If you chose DHCP then your network router will set these automatically. If you chose Manually Entered IP then contact your network IT manager for the appropriate settings.

#### **Wireless Settings:**

**Enable Wireless:** This will turn the wireless radio on/off. No wireless networks are displayed when this is disabled.

**Networks:** When wireless is enabled the system will search for wireless networks that are available and display them in this list. Networks that have been previously accessed will show up with an asterisk (“\*”). If there is currently an active network it will show up with a checkmark (‘√’). If the network requires a password it shows up with a lock icon. Each displayed network shows the strength of the wireless signal.

**Refresh:** Clicking on this button updates the list of displayed networks.

The following controls require that a wireless network has been selected from the network list. Click on the name of a network to select it.

**Join:** This joins the selected network. If a password is needed a dialog box will be displayed to



enter it.

**Forget Network:** This forgets any password of the selected network that had been entered, but the network is still shown in the list.

**Advanced Settings:** This brings up a dialog box with additional settings for the selected wireless network. The dialog box includes the following:

- **Password:** This is useful when the network password has changed.
- **Method:** Either Manually entered (Static) or DHCP. Generally wireless networks use DHCP, and a Static address is only needed if required by the target PACS system.
- **IP Address, Subnet Mask, Gateway, DNS:** If you chose DHCP then your network router will set these automatically. If you chose Manually Entered IP then contact your network IT manager for the appropriate settings.

## 11.2.2. DICOM

This screen configures DICOM services, including DICOM Store, Modality Worklist, MPPS Service, DICOM Print, etc.

Figure 11-7 DICOM Settings

### 11.2.2.1. DICOM Network Settings

All the DICOM services require to configure the network settings. These settings include:

#### a. Local Settings:

These settings determine how the system communicates with other DICOM devices.

**Local AE Title:** Any 16 characters that uniquely identify this system on your DICOM network. The default “EDAN\_STR\_SCU” will work unless you have multiple Edan systems on your network.

**Time Out:** This determines the time after which this system will stop trying to establish a connection to the DICOM server.

#### b. Server Settings:

The server list displays all the configured servers. It starts off as an empty list, and grows as servers are added. Most sites will only use one server, but if the system is moved between locations then multiple servers may be entered. Clicking in any field in this list will select that server. Depending on the exact level of software a second click may be needed to edit that field. The fields are:

- **Name:** The name of the server that appears in the drop-down list of the exam database.
- **AE Title, IP Address, Port:** These are the settings of the destination DICOM server; it's how the system finds the DICOM server on your network. The AE title and IP Address are unique to your network; contact your network IT manager for these settings. The most common setting of Remote Port for DICOM servers is 104, although your server may be different.
- **Storage-TLS:** Sets whether to use the TLS protocol to encrypt DICOM store process.  
Note:  
The precondition of using TLS protocol to encrypt DICOM store process is that the DICOM server should support TLS protocol.
- **Testing the server:** There are two tests to ensure that the server information is entered correctly. Click on any field for a given server to make that server selected, then:
  - **Ping:** A successful Ping means that the system can communicate with the server at a low-level; basically that the two computers 'see' each other. As a security measure, some servers on the Internet may be configured to not respond to a Ping even if the connection is successful.
  - **Verify:** A successful Verify means that the system can communicate with the server at a DICOM level; basically that the DICOM on both computers understand each other. A successful Verify will typically mean that your DICOM configuration is correct.
- **Other controls:**
  - **Add:** Adds another line in the list of servers.
  - **Delete:** Deletes the selected server.

#### 11.2.2.2. DICOM Store Settings

Click **Store** key on the left side of main screen, and the right half screen switches to DICOM Store setup, where you can configuring DICOM Storage.

- **Server:** Selects a configured server from the drop-down list as the default server for Auto-transfer.
- **Transfer Syntax:** Sets the transfer syntax for DICOM storage.
- **DICOM Store:** Determines when DICOM images and clips are sent to the server. The options are:
  - **Transfer on demand:** Images, clips and structured reports are only sent when you manually send them. When there is no exam in progress the Review hard key will show a list of all exams on the hard drive. Select an exam and press the Send button at the bottom of the screen.
  - **Auto-Transfer when Store:** Each image or clip is sent automatically when it is captured. This has the advantage that images and clips are immediately available for review at the server while the exam is in progress. It has the disadvantage that, due

to the nature of DICOM, images that are already sent can not be deleted from the server from the system.

- **Auto Transfer when End Exam:** Images, clips and structured reports are sent automatically when the exam is ended. This is the most common setting.
- **SR Configuration:** This brings up a dialog box for detailed structured report configuration. The dialog box includes the following:
  - **Send SR with Images:** This will enable the function of sending structured report together with images to a DICOM server.
  - **Report Type:** This determines the type of structured report. Select Enhanced report or Comprehensive report according to the report type your PACS system requires.
  - **Data Configuration:** This determines whether a report with All Results or with only Summary Results will be sent. All results include all the individual measurement results of each measurement and its summary results in the worksheet, while summary results come from all the individual measurement results by the method of average, maximum, minimum or last which is decided by the user in the worksheet.
  - **Sequence Delimiter:** This determines the method to indicate the end of a DICOM sequence. Undefined and Explicit are available.

### 11.2.2.3. Modality Worklist Settings

Click **Worklist** key on the left side of main screen, and the right half screen switches to Modality Worklist setup, where you can configuring Modality Worklist.

- **Enable:** Turns Modality Worklist on/off.
- **Server:** Selects a configured server from the drop-down list as the default server to query for the worklist.
- **Comment Source:** Modality Worklist can fill the ultrasound comments section from the server. Depending on
  - **Patient Comments:** Obtains comments from DICOM tag (0x0010,0x4000);
  - **Scheduled Procedure Description:** Obtains comments from DICOM tag (0x0040,0x0007)
  - **Comments on Schedule Procedure:** Obtains comments from DICOM tag (0x0040,0x0400)
- **Update Worklist:** Determines when the worklist is updated. Choices are:
  - **On Demand:** Updates only when the Update button is pressed from the patient page.
  - **Every 15 Minutes:** Updates on power-up and then regularly every 15 minutes.
  - **Every hour:** Updates on power-up and then regularly every hour.
  - **On Start of Exam:** Updates when the patient page is displayed at the start of each exam.
- **Date Range:** The range of dates for the worklist query. Note, the option of “Yesterday and Tomorrow” includes today’s exams.
- **Map SPSD:** Checking this item, the Study Description on Patient information page will show study description and as well as SPSD(Scheduled Procedure Steps Description) obtained from Worklist server. Otherwise only shows the study description.

#### 11.2.2.4. **MPPS Service Settings**

Click **MPPS** key on the left side of main screen, and the right half screen switches to MPPS service setup, where you can configuring MPPS service.

**Enable:** Turns MPPS (Modality Performing Procedure Step) service on/off. If MPPS service is on, the ultrasound system will send the exam status to Worklist server automatically when starting or ending an exam.

#### 11.2.2.5. **DICOM Print Settings**

Click **Print** key on the left side of main screen, and the right half screen switches to DICOM Print setup, where you can configuring DICOM Print.

- **DICOM Print Server:** Determines which configured DICOM server will do the image printing.
- **Color Mode:** Determines the color mode of images. Currently only gray mode is supported.
- **Number of Copies:** Determines how many copies of files are printed in a single image printing operation.
- **Print Priority:** Determines where the image printing is inserted into the queue in the DICOM printer. Three options of High, Medium and Low are available. For High priority, the image is printed first among the queued printing tasks.
- **Image Display Format:** Determines the layout of images displayed on a printed file. Only "1,1" format is available for this release.
- **Medium Type:** Determines the storage medium of DICOM print. Paper and Film are available.
- **Film Orientation:** Determines the orientation of the film. Portrait and Landscape are available.
- **File Size:** Determines the size of the film being used. Make sure the designated size is the same as the size of the currently loaded film.
- **Trim:** Determine whether a trim box to be printed around each image on the film.
- **Min Film Density:** Determines the minimum film density. The default value is 0.
- **Max Film Density:** Determines the maximum film density. The default value is 300.
- **Border Density:** Determines the density of the border area around the image on the film. Black and White are available.
- **Empty Image Density:** Determines the density of the empty image area on the film. Black and White are available.
- **Magnification Type:** Determines how the printer magnifies an image to fit the film. Interpolation methods of Replicate, Bilinear and Cubic are available. Generally, Cubic provides the best results, followed by Bilinear.
- **Smoothing Type:** Determines the smoothing method for the image. Default and None are available.
- **Resolution:** Determines the resolution of the image. Standard and High resolution are available.
- **Support 12 Bit:** Determines whether to use 12-bit printers to do the imaging printing.

#### 11.2.2.6. **DICOM Storage Commitment**

Click **Storage Commitment** key on the left side of main screen, and the right half screen switches to DICOM Storage Commitment setup, where you can configuring DICOM Storage Commitment.

- **Enable:** Turns DICOM Storage Commitment function on/off.

- **Server:** Selects a configured server from the drop-down list to confirm whether the DICOM transfer to this server is successful. The confirmation is undergoing in the background. When an exam's transfer to the DICOM server is confirmed successfully, a small red disk icon appears next to this exam on the Exam Database screen, indicating that it has been saved successfully on the DICOM server.

### 11.2.2.7. Query/Retrieve

Click **Query/Retrieve** key on the left side of main screen, and on the right half screen you can configure a DICOM server for the query/retrieve of prior exams. For the operations of query/retrieve of prior exams, please see section *9.3 Exam Database*.

### 11.2.3. Network Store

This screen configures the system to connect to an FTP server on the local network. This allows the system to store files to a local server without using DICOM. To use this, a PC or server needs to be configured as an FTP server on the local network. The mechanism to do this depends on the operating system used. Please contact your local IT support for assistance.

Once configured, studies can be sent to the FTP server from the Exam Database shown in Review. Studies are sent to the configured folder, where each study appears in a separate folder with the name of the patient and the study date.

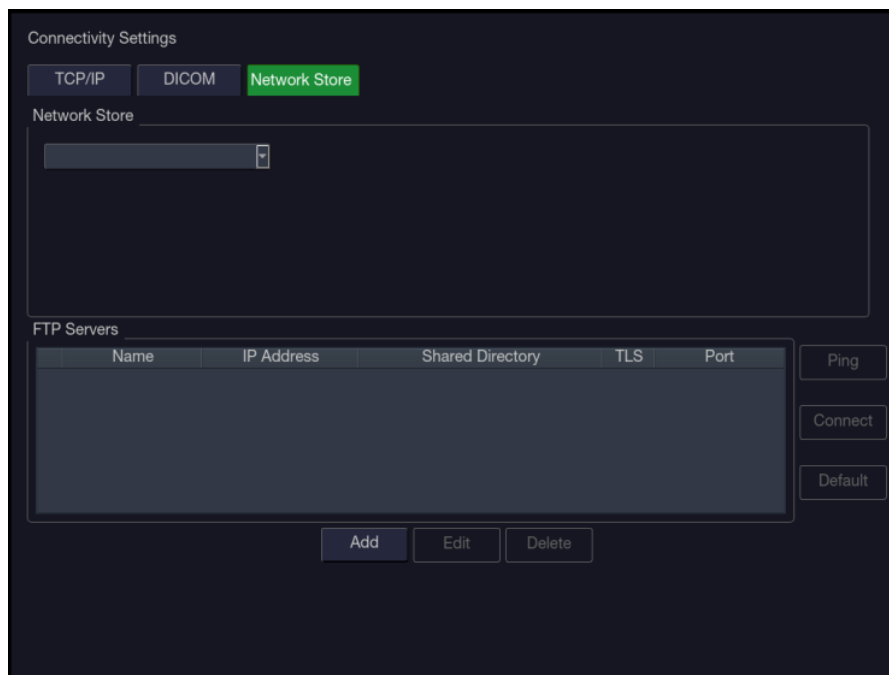


Figure 11-8 Network Store Set-up Screen

**FTP Server list:** The main interaction in this section is a list of configured servers and directories. It starts off as an empty list, and grows as servers are added. Most sites will only use one, but if the system is moved between locations then multiple entries may be useful. Clicking in any field in this list will select that server.

- **Name:** The name of the server that appears in the drop-down list of the patient database.
- **IP Address, Shared Directory:** These are the address of the FTP server and the directory used on that server.
- **TLS:** Sets whether to use TLS protocol to encrypt the FTP transfer.

- **Port:** Sets the port number of FTP server.

**Testing the server:** There are two tests to ensure that the server information is entered correctly. Click on any field for a given server to make that server selected, then:

- **Ping:** A successful Ping means that the system can communicate with the FTP server at a low-level; basically that the two computers 'see' each other. As a security measure, some servers on the Internet may be configured to not respond to a Ping even if the connection is successful.
- **Connect:** A successful Connect means that the system can communicate with the FTP server, and FTP transfers will work. If this fails but Ping works it could mean:
  - The destination computer is not correctly configured as an FTP server.
  - The password on the server has changed. Use Edit to re-enter the password.
  - The Shared Directory does not exist. Use Edit to confirm the directory.

#### **Other Controls**

- **Add:** Adds another line in the list of servers. This automatically invokes Edit.
- **Edit:** Available when an FTP Server has been selected. This invokes a dialog that edits the IP address, name, directory, and password.
- **Delete:** Available when an FTP Server has been selected. This deletes the selected server.

## **11.3 Maintenance**

### **Entering Maintenance Screen:**

Press **Utilities**-> **Maintenance** touch screen buttons to access Connectivity screens.

The Maintenance screens provide access to controls that are not typically needed during normal operation of the system.

### **11.3.1. License**

The **License** page displays which features are currently licensed for use on the system. At the top of the screen is displayed the current license key. Below that is a list of all licensable features, along with its current status. The system supports temporary trial licenses. Click the **Trial** button can try the function for one time in the valid period of three months. If a feature is so licensed the expiration date is also shown.

- Press **Import** button to import a license file from a USB external storage device.
- Press **Revert** button to restore the previous license if the imported license is not correct.

Please contact your distributor or Edan service engineer to obtain a new license key.

### **11.3.2. Version**

The **Version** screen shows the current version of software, firmware, and selected hardware for the system. This information is only needed if requested by an Edan service engineer. This page also includes an **Upgrade, Import Config** and **Show Config** button. Any released upgrade will include instructions regarding use of this button.

**Caution**

1. Anti-virus measures such as USB device virus scanning should be carried out prior to using USB flash drive.
2. Do not connect an USB device with unknown provenance to the ultrasound system.
3. To avoid loss of patient data, please backup the patient data prior to software upgrade.

**11.3.3. Demo**

A Demo exam is a special exam with a patient name of "Demo". It allows you to collect any set of images from multiple exams.

To create a Demo exam:

1. Export the desired images you want as DICOM format from the system to a USB external storage device. (See section 9.4)
2. Using a computer, create a folder named "Demo" under the folder "Ultra\_Images" on the USB external storage device.
3. Move the exported images to the "Demo" folder.
4. Connect the USB external storage device to a system. Press **Utilities-> Maintenance-> Demo** touch screen buttons.
5. Press **Import** button, and select the USB device.
6. Press **OK** to start copying the images from the USB device to the Demo exam.
7. If "Enable Demo" is checked the imported Demo exam will show up in the Exam Database list.

To Export a Demo exam:

1. Once a Demo exam is imported to the system and the Demo function is enabled, you can add the desired image to the Demo exam.
2. When reviewing images, select the desired images first and then press "To Demo" key on the touch screen to add these images to the Demo exam. (See Section 9.2)
3. Connect the USB external storage device to the system. Press **Utilities-> Maintenance-> Demo** touch screen buttons.
4. Press **Export** button, and all the images including the added images of the Demo exam will be exported to the USB device in a folder named "Demo" under the folder "Ultra\_Images"

**11.3.4. Export/Import**

The system supports export/import of user-configured presets and settings to an external storage device. This same UI supports the export of system log files.

**To export user data:**

1. Press **Utilities** touch screen button, select **Maintenance → Export/Import → Export**.
2. Select an external USB storage device.
3. Check the items to be exported: Image Presets, Comment Presets, Body Mark Presets, User Settings, System Log, Findings. The Preset items can be expanded to select a specific preset.
  - Each type of preset can be expanded using the arrow graphics on the left side. This allows you to export/import any subset of any type of preset.
4. Press **Export** button to begin the export process.

The User Settings includes all system setting data described in section 11.1. It also contains the

links between layers of presets. For example, suppose a system has a user-created comment preset that was named 'my\_ABD\_comments' that was linked to the Abdomen exam preset on that system. Exporting those presets and then importing them to a different system would not link 'my\_ABD\_comments' to the Abdomen exam preset on the new system, unless the User Settings were also exported/imported.

**To import user data:**

1. Press **Utilities** touch screen button, select **Maintenance** → **Export/Import** → **Import**.
2. Select an external USB storage device. All the presets on it will be loaded and displayed. The Presets must have been previously exported from a system.
3. Check the items to be imported: Image Presets, Comment Presets, Body Mark Presets, User Settings, Findings. The Preset items can be expanded to select a specific preset.
4. Press **Import** button to begin the import process.

Note:

Import of **System Logs** is not supported.

## 11.4 Screen Adjust

The brightness and contrast of the monitor and touch screen in the system can be customized. Press **Utilities** touch screen button, select **Screen Adjust** to customize the below brightness and contrast:

- **Main Screen Brightness:** adjusts the brightness value of the monitor.
- **Main Screen Contrast:** adjusts the contrast value of the monitor.
- **Main Screen ColorTemp.:** adjusts the color temperature of the main screen.
- **Touch Screen Brightness:** adjusts the brightness value of the touch screen.

Press **Restore Default** button to restore the factory settings for all the brightness and contrast values.



## Appendix A Specifications

### A.1 Electrical Safety Classifications

According to the type of protection against electric shock	Internally powered equipment, Class I equipment
According to the degree of protection against electric shock	Type BF Type CF(ECG module)
According to the degree of protection against harmful ingress of liquid	Whole device: IPX0 Transducer (not including the transducer connector): IPX7; Footswitch: IP68
According to the degree of safety of application in the presence of a flammable gas	Equipment not suitable for use in the presence of a flammable gas
According to the mode of operation	Continuous operation
According to the grade of EMC	CISPR 11 Group 1, Class A
Standards Compliance	EN 60601-1:2006/A1:2013 idt IEC 60601-1: 2005/A1:2012 EN 60601-1-2: 2015 idt IEC 60601-1-2: 2014 EN 60601-2-37:2018/A1:2015 idt IEC 60601-2-37:2007/A1:2015 UD2

### A.2 Power Supply

Operating Voltage	100 -240 V~
Operating Frequency	50 Hz/60 Hz
AC Input Current	2.5A-1.2A

### A.3 Battery

Capacity	5000 mAh
Voltage	14.8V
Working time	About 1.5 hours(1/2 scanning+1/2 frozen)
Charging time	About 5 hours.
Cycle life	>300

## A.4 Machine Specifications

Main unit dimensions	Maximum dimension: 1776 ± 5mm(H) × 550 ± 3mm(W) × 828 ± 3mm(D)
Net weight	73kg (not including transducer and accessories)

## A.5 Display Specifications

Display	TFT-LCD
Diagonal Size	21.5 inch
View Angle	Right 178°, Left 178°, Up 178°, Down 178°
Pixel Number	1920x1080
Contrast Ratio	1000 (Typical)

## A.6 Technical Specifications

<b>General Specifications</b>	
Display Modes	<p>B Mode: Single, Dual, Quad</p> <p>C Mode: B/C(Single, Dual, Quad); B+B/C(Dual Live); B/C/PW(Triplex mode)</p> <p>PDI/DPDI Mode: B/PDI(DPDI) (Single, Dual, Quad); B+B/PDI(DPDI) (Dual Live); B/PDI(DPDI)/PW (Triplex mode)</p> <p>PW Mode: B/PW;(Update) B/PW; (duplex, simultaneous) B/C/PW(Update) B/C/PW, B/PDI(DPDI)/PW; (triplex mode)</p> <p>CW Mode: B/CW; B/C/CW, B/PDI(DPDI)/CW;</p> <p>M Mode: B/M (Display layout: Up/down, Left/right, 1:1)</p> <p>TDI Mode: B+ Color-TDI (Dual Live) B+PW-TDI (Update) B+ PW-TDI(duplex, simultaneous) B+ Color-TDI + PW-TDI (Update) B+ Color-TDI + PW-TDI ((triplex mode)</p> <p>3D/4D: 3D Rendering, 3 Sectional Planes</p>

	Elastography: E, B+E(Display layout: Up/down, Left/right, 1:1); Contrast: C, T+C
Hard Drive Storage	1TB (HHD, Standard) 120GB (SSD, Optional)
Report Packages	Abdomen, Obstetrics, Small Parts, Vascular, Cardiac, Gynecology, Urology, Pediatric
<b>Wi-Fi Specifications</b>	
Standard Conformance	802.11b, 802.11g ,802.11n
Frequency Band	2.412-2.472GHz(@2.4GHz band)
Modulation Technique	OFDM, CCK, DQPSK, BPSK
Typical Transmit Power (±2dBm)	802.11b: 17dBm 802.11g: 15 dBm 802.11n: 14 dBm
<b>Wi-Fi Quality of Service</b>	
Data rate	802.11b: up to 11 Mbps @ 2.4 Ghz 802.11g: up to 54 Mbps @ 2.4 Ghz 802.11n: up to 65 Mbps @ 2.4 Ghz
Data security	WPA2 encryption
Application-layer delay	No requirement. It's not used in real time.
Application-layer reliability	No requirement. Application failure will be notified to the user immediately.
System capacity	No more than one device will be allowed to connect with the ultrasound system.
System anti-interference	Can be coexistent with other Wi-Fi devices.
Network interruption alarm	Network interruption is notified by disconnection icon and failure in transmission is notified in Transfer Status window.
EMC test process	Wi-Fi function is not affected when the system is imposed with radiation interference complied with IEC60601-1-2:2014 standard.
<b>ECG Specifications</b>	
Patient Cable	IEC, AHA
Lead Mode	3-Lead: I, II, III
AC Filter	50 Hz, 60 Hz
HR Range and Accuracy	Adult: 15 bpm to 300 bpm Pediatric: 15 bpm to 350 bpm Resolution: 1 bpm

	Accuracy: $\pm 1\%$ or 1 bpm, whichever is greater.
QRS Detection	Range: 40 ms~120 ms
	Amplitude:0.5 mV~5 mV
Patient Leakage Current	< 10 $\mu$ A

## ***A.7 Operating, Storage and Transportation Environment***

### ***A.7.1 Operating Environment***

Temperature	0 °C ~ +40 °C(+32 °F~+104 °F)
Relative humidity range	15% RH ~ 95% RH(non-condensing)
Atmospheric pressure range	86kPa ~ 106kPa

### ***A.7.2 Storage and Transportation Environment***

Temperature	-20 °C ~ +55 °C(-4 °F~+131 °F)
Relative humidity range	15% RH ~ 95% RH(non-condensing)
Atmospheric pressure range	70kPa ~ 106kPa

## ***A.8 Transducer Specifications***

<b><i>No.</i></b>	<b><i>Transducer</i></b>	<b><i>Center Frequency</i></b>	<b><i>No.</i></b>	<b><i>Transducer</i></b>	<b><i>Center Frequency</i></b>
1	L17-7HQ	12.0MHz	2	E8-4Q	6.2MHz
3	C6-2MQ	4.0MHz	4	C5-1Q	3.0MHz
5	C5-2Q	3.5MHz	6	L12-5Q	8.0MHz
7	L17-7SQ	12.0MHz	8	MC8-4Q	6.0MHz
9	P5-1Q	2.7MHz	10	P7-3Q	5.0MHz
11	MC9-3TQ	6.0MHz	12	C7-2XQ	4.5MHz
13	E10-3BQ	6.2MHz	14	E10-3HQ	6.2MHz

## **A.9 Configuration Difference**

<b>Models</b>	<b>Configuration Difference</b>		
	<b>Feature 1</b>	<b>Feature 2</b>	<b>Feature 3</b>
	<b>Seminal Vesicle Meas.</b>	<b>Testis Meas.</b>	<b>Single Button Footswitch</b>
Acclarix LX9	X	√	√
Acclarix LX9 Exp	√	X	√
Acclarix LX9 Super	√	√	√
Acclarix LX85	X	√	X
Acclarix LX88	√	X	X

## **Appendix B Ultrasound Intensity and Safety**

### **B.1 Ultrasound in Medicine**

The use of diagnostic ultrasound has proved to be a valuable tool in medical practice. Given its known benefits for non-invasive investigations and medical diagnosis, including investigation of the human fetus, the question of clinical safety with regards to ultrasound intensity arises.

There is no easy answer to the question of safety surrounding the use of diagnostic ultrasound equipment. Application of the ALARA (As Low As Reasonably Achievable) principle serves as a rule-of-thumb that will help you to get reasonable results with the lowest possible ultrasonic output.

The American Institute of Ultrasound in Medicine (AIUM) states that given its track record of over 25 years of use and no confirmed biological effects on patients or instrument operators, the benefits of the prudent use of diagnostic ultrasound clearly outweigh any risks.

### **B.2 Ultrasound Safety and the ALARA Principle**

Ultrasound waves dissipate energy in the form of heat and can therefore cause tissue warming. Although this effect is extremely low with Transcranial Doppler, it is important to know how to control and limit patient exposure. Major governing bodies in ultrasound have issued statements to the effect that there are no known adverse effects from the use of diagnostic ultrasound, however, exposure levels should always be limited to As Low As Reasonably Achievable (the ALARA principle).

#### **Imaging Functions Affecting Acoustic Output**

In addition to the level of voltage transmitted, adjustment of the following imaging functions and /or controls may affect the acoustic output.

<b>Item</b>	<b>Affection</b>
Probe	Acoustic output will be changed with the change of probe.
Imaging mode	There are different parameters applied in B mode, Color mode, M mode, and PW mode, so acoustic output will be changed with the change of among B mode, Color mode, M mode, and PW mode.
Field of view (scan angle or scan width)	Frame rate may be changed with the change of the scan angle or the scan width, and the acoustic output will also be changed.
Image depth	Pulse repeated frequency will be changed with the change of the image depth, and the acoustic output will be changed.
Focus number	Frame rate and focus position will be changed with the change of the focus number, and acoustic output will also be changed.
Focus position	Beam power level and the beam aperture will be changed with the change of the focus position, and acoustic output will also be changed.
Freeze	When freezing the system, it will stop transmitting ultrasonic wave.
Transmission power	The output of probe will be changed with the change of the transmission power, and acoustic output will be changed.
Multi-frequency	The character of the wave focus will be changed with the change of the frequency, and acoustic output will be changed.

Line density	The acoustic output will be changed with the change of the number of the scanning line (line density).
PRF	The acoustic power will be changed with the change of PRF.
Sample volume	The pulsed wave and the power will be changed with the change of the sample volume, and acoustic output will be changed.
Presets	Presets contain all the parameters above, so any change of the presetting will change acoustic output.
Restart, or power on/off	System will return to the default setting when restarting, or powering on/off the system, and acoustic output will be changed.

## **B.3 Explanation of MI/TI**

### **B.3.1 MI (Mechanical Index)**

Cavitations will be generated when ultrasound wave passes through and contacts tissues, resulting in instantaneous local overheating. This phenomenon is determined by acoustic pressure, spectrum, focus, transmission mode, and factors such as states and properties of the tissue and boundary. This mechanical bioeffect is a threshold phenomenon that occurs when a certain level of ultrasound output is exceeded. The threshold is related to the type of tissue. Although no confirmed adverse mechanical effects on patients or mammals caused by exposure at intensities typical of present diagnostic ultrasound instruments have ever been reported, the threshold for cavitation is still undetermined. Generally speaking, the higher the acoustic pressure, the greater the potential for mechanical bioeffects; the lower the acoustic frequency, the greater the potential for mechanical bioeffects.

The AIUM and NEMA formulate mechanical index (MI) in order to indicate the potential for mechanical effects. The MI is defined as the ratio of the peak-rarefactional acoustic pressure (should be calculated by tissue acoustic attenuation coefficient 0.3dB/cm/MHz) to the square root of acoustic frequency.

$$MI = \frac{P_{r,a}}{\sqrt{f_{awf}} \times C_{MI}}$$

Where,  $C_{MI} = 1 \text{ Mpa} \cdot \text{MHz}^{-1/2}$ ,  $P_{r,a}$  is the Attenuated Peak-rare-factional Acoustic Pressure and  $f_{awf}$  is Acoustic Working Frequency.

### **B.3.2 TI (Thermal Index)**

Heating of tissues is caused by absorption of ultrasound when the ultrasound energy is applied. The temperature rise is determined by the acoustic intensity, exposed area and thermophysical properties of the tissue.

In order to indicate the potential for temperature rise caused by thermal effects, the AIUM and NEMA formulate thermal index (TI). It is defined as the ratio of the total acoustic power to the acoustic power required to raise the tissue temperature by 1°C.

According to different thermophysical properties of the tissue, TI is divided into three kinds: TIS, TIB and TIC.

TIS (Soft Tissue Thermal Index): It provides an estimate of potential temperature rise in soft or similar tissues.

TIB (Bone Thermal Index): It provides an estimate of potential temperature rise when the ultrasound beam passes through soft tissue and a focal region is in the immediate vicinity of bone.

TIC (Cranial Bone Thermal Index): It provides an estimate of potential temperature rise in the cranial bones or superficial bones.

### **B.3.3 Display of MI/TI**

The system provides real-time display of MI/TI values in the upper right part of the screen. The start point of MI/TI value is 0.0.

The operator should monitor these values during examinations and keep the exposure time and output level at the minimum amounts needed for effective diagnosis.

The display precision is 0.1.

MI display error:

When measured  $MI \leq 0.5$ , the absolute display error  $\leq 0.25$ ;

When measured  $MI > 0.5$ , the relative display error  $\leq \pm 50\%$ .

TI display error:

When measured  $TI \leq 2.0$ , the absolute display error  $\leq 1.0$ ;

When measured  $TI > 2.0$ , the relative display error  $\leq \pm 50\%$ .

## **B.4 Acoustic Output**

### **B.4.1 Factors that Contribute to Uncertainty in the Output Display**

A number of factors should be considered in display accuracy determination methods, such as:

- Transducer variability
- System variability
- Measurement variability and accuracy
- The number of operating conditions of which the system is capable and the number tested in obtaining display accuracy results
- Whether display accuracy will be determined by specific combinations of system, mode, transducer assembly and transmit patterns, or all allowed combinations of them
- Accuracy of system software MI and TI calculation algorithms.
- Engineering approximations for real-time calculations

### **B.4.2 Differences between Actual and Displayed MI/TI**

Actually, many assumptions adopted in the process of measurement and calculations are relatively conservative. Over-estimation of actual in situ intensity exposure, for the majority of tissue paths, is made to the measurement and calculation process. For example, attenuation coefficient of 0.3 dB/cm·MHz, which is much lower than the actual value for most tissues of the body, is adopted. And conservative values of tissue characteristics are selected for use in TI models. Therefore, the display of MI and TI should be used as relative information to assist operator in prudent use of ultrasound system and implementation of ALARA principle, and the values should not be interpreted as the actual physical values in tissues or organs examined.

### **B.4.3 Measurement Uncertainty**

**Measurement uncertainties table**

	<b>Intensity</b>	<b>Pressure</b>	<b>Power</b>	<b>Center frequency</b>	<b>MI</b>
Uncertainty(K=2)	±29.59%	±14.80%	±29.59%	±0.20%	±14.80%



### **B.4.4 Acoustic Power Default Settings**

The ultrasound system allows direct control of acoustic power by the Power paddle key on the touch screen. The range can be adjusted is 10% to 100%. The higher the acoustic power number, the greater the acoustic output.

The factory default settings of acoustic power is 100%. The default settings can be reconfigured by the operator through the Acoustic Power item on **Utilities->Set up->Preset** page. The ultrasound system switch to default settings upon power up, new patient, new exam or new transducer.

### **B.5 Operator Control Features**

The possibility of producing mechanical/thermal biological effects can be influenced by three kinds of controls: Direct Controls, Indirect Controls, and Receiver Controls. The qualified operator may use the system controls to minimize the ultrasound output while acquiring necessary clinical information.

#### ◆ Direct Controls

The acoustic output of the system can be controlled directly through the level of voltage transmitted. In this case, the maximum acoustic output never exceeds the limits in any mode of operation.

#### ◆ Indirect Controls

The acoustic output of the system can be controlled indirectly through many imaging parameters, including imaging modes, field of view, line density, probe frequency, focus number/position, depth and pulse repetition frequency (PRF).

The imaging mode determines whether the ultrasound beam is scanning or non-scanning. Thermal bioeffect is closely associated with B, M, PW and Color mode.

Acoustic attenuation of tissue is directly connected to probe frequency.

The focus number/position is related to active aperture of probe, beam width and frame rate.

The higher PRF (pulse repetition frequency), the more output pulses occur over a period of time.

#### ◆ Receiver Controls

The receiver controls (such as gain, TGC, dynamic range and image processing), which are used to improve image quality, have no effect on acoustic output. Thus these controls should be optimized before increasing acoustic output.

### **B.6 Prudent Use Statement**

Although no confirmed bioeffects on patients caused by exposure from present diagnostic ultrasound equipment have ever been reported, the potential exists that such bioeffects may be identified in the future. Therefore, the ultrasound should be used prudently. High levels of acoustic output and long exposure time should be avoided while acquiring necessary clinical information.

### **B.7 References for Acoustic Output and Safety**

1. "Bioeffects and Safety of Diagnostic Ultrasound" issued by AIUM in 1993
2. "Medical Ultrasound Safety" issued by AIUM in 1994
3. "Acoustic Output Measurement Standard for Diagnostic Ultrasound Equipment, Revision 3" issued by AIUM/NEMA in 2004
4. "Information for Manufacturers Seeking Marketing Clearance of Diagnostic Ultrasound Systems and Transducers" issued in 2008.
5. IEC60601-2-37, Medical electrical equipment - Part 2-37:2007+AMD1:2015 Particular requirements for the basic safety and essential performance of ultrasonic medical diagnostic and monitoring equipment, International Electro technical Commission.

6. Roy C. Preston, David R. Bacon, and Robert A. Smith, Calibration of Medical Ultrasonic Equipment - Procedures and Accuracy Assessment, IEEE Transactions on Ultrasonics, Ferroelectrics, and Frequency Control, Vol. 35, No. 2, page110, March 1988.

### ***B.8 Transducer Acoustic Output Data***

Please refer to the User Manual Advanced Volume(P/N: 01.54.458127) for details acoustic output data of each transducer.

## Appendix C Order List

The following accessories are recommended for use on the system.

### **WARNING**

Only accessories supplied or recommended by EDAN can be used, the transducers of EDAN can be only used on EDAN's systems. Otherwise, the performance and electric shock protection cannot be guaranteed. If electrical or mechanical equipment from other companies need to be connected to the device, please contact EDAN or authorized representatives before connection.

<b>Part Name</b>	<b>Part Number</b>
Transducer L17-7HQ	02.01.211856
Transducer E8-4Q	02.01.214513
Transducer C5-2Q	02.01.212622
Transducer L12-5Q	02.01.212623
Transducer L17-7SQ	02.01.211857
Transducer MC8-4Q	02.01.212625
Transducer P5-1Q	02.01.213916
Transducer P7-3Q	02.01.214038
Transducer MC9-3TQ	02.01.213995
Transducer C7-2XQ	02.01.214827
Transducer E10-3BQ	02.01.214793
Transducer E10-3HQ	02.01.214791
Transducer C6-2MQ	02.01.214776
Transducer C5-1Q	02.01.214783
BGK-C5-2 Needle Guide Bracket Kit	02.01.211006
BGK-L40UB Needle Guide Bracket Kit	02.01.210407
BGK-CR10UA Needle Guide Bracket Kit	02.01.102963
BGK-R15UB Needle Guide Bracket Kit	02.01.210618
BGK-001 Needle Guide Bracket Kit	02.01.215191

BGK-004 Needle Guide Bracket Kit	02.01.215194
BGK-005 Needle Guide Bracket Kit	02.01.215372
BGK-006 Needle Guide Bracket Kit	02.01.215373
BGK-007 Needle Guide Bracket Kit	02.01.215514
Power Cable, European Standard	01.13.036638
Power Cable, American Standard	21.13.036384
Lithium-Ion battery	01.21.064143
Ultrasound Gel	01.57.078008
USB Disk	01.18.052245
Footswitch(single button)	01.10.000910
Fottswitch(doule button)	01.10.027323
ECG patient cable, 3-lead, IEC, Defib, Snap	01.57.471379
ECG patient cable, 3-lead, AHA, Defib, Snap	01.57.471380
ECG electrodes, disposable	01.57.471858

NOTE: The part name may vary depending on context, but the part number is constant.

## Appendix D EMC Information

### Electromagnetic emissions

<b>Guidance and manufacture's declaration – electromagnetic emission</b>		
The system is intended for use in the electromagnetic environment specified below; The customer or the user of the system should assure that it is used in such an environment.		
<b>Emission test</b>	<b>Compliance</b>	<b>Electromagnetic environment – guidance</b>
RF emissions CISPR 11	Group 1	The system uses RF energy only for its internal function. Therefore, its RF emissions are very low and are not likely to cause any interference in nearby electronic equipment.
RF emissions CISPR 11	Class A	The system is suitable for use in all establishments other than domestic and those directly connected to the public low-voltage power supply network that supplies buildings used for domestic purposes.
Harmonic emissions IEC 61000-3-2	Class A	
Voltage fluctuations/flicker emissions IEC61000-3-3	Complies	

#### **NOTE:**

The EMISSIONS characteristics of the system make it suitable for use in industrial areas and hospitals (CISPR 11 class A). If it is used in a residential environment (for which CISPR 11 class B is normally required) the system might not offer adequate protection to radio-frequency communication services. The user might need to take mitigation measures, such as relocating or re-orienting the equipment.

**Electromagnetic immunity****Guidance and manufacture's declaration – electromagnetic immunity**

The system is intended for use in the electromagnetic environment specified below. The customer or the user of the system should assure that they are used in such an environment.


<b>Immunity test</b>	<b>IEC/EN 60601 test level</b>	<b>Compliance level</b>	<b>Electromagnetic environment - guidance</b>
Electrostatic discharge (ESD) IEC/EN 61000-4-2	± 8 kV contact ± 15 kV air	± 8 kV contact ± 15 kV air	Floors should be wood, concrete or ceramic tile. If floor are covered with synthetic material, the relative humidity should be at least 30%.
Electrical fast transient/burst IEC/EN 61000-4-4	±2 kV for power supply lines	±2kV for power supply lines	Mains power quality should be that of a typical commercial or hospital environment.
Surge IEC/EN 61000-4-5	±1 kV for line to line ±2 kV for line to ground	±1 kV for line to line ±2 kV for line to ground	Mains power quality should be that of a typical commercial or hospital environment.
Power frequency (50/60Hz) magnetic field IEC/EN 61000-4-8	30 A/m	30 A/m	Power frequency magnetic fields should be at levels characteristic of a typical location in a typical commercial or hospital environment.
Voltage dips, short interruptions and voltage variations on power supply input lines IEC/EN 61000-4-11	0 % $U_T$ ; 0.5 cycle At 0°, 45°, 90°, 135°, 180°, 225°, 270° and 315°  0 % $U_T$ ; 1 cycle and 70 % $U_T$ ; 25/30 cycles ) Single phase: at 0°  0 % $U_T$ ; 250/300 cycle	0 % $U_T$ ; 0.5 cycle At 0°, 45°, 90°, 135°, 180°, 225°, 270° and 315° 0 % $U_T$ ; 1 cycle and 70 % $U_T$ ; 25/30 cycles Single phase: at 0° 0 % $U_T$ ; 250/300 cycle	Mains power quality should be that of a typical commercial or hospital environment. If the user of the system requires continued operation during power mains interruptions, it is recommended that the system be powered from an uninterruptible power supply or a battery.

**NOTE**  $U_T$  is the a.c. mains voltage prior to application of the test level.

**Electromagnetic immunity**

**Guidance and manufacture’s declaration – electromagnetic immunity**

The system is intended for use in the electromagnetic environment specified below. The customer or the user of the system should assure that they are used in such an environment.

<b>Immunity test</b>	<b>IEC/EN 60601 test level</b>	<b>Compliance level</b>	<b>Electromagnetic environment - guidance</b>
<p>Conducted RF IEC/EN 61000-4-6 Radiated RF IEC/EN 61000-4-3</p>	<p>3 V<sub>rms</sub> 150 kHz to 80 MHz 6V<sub>rms</sub><sup>c</sup> in ISM bands between 0.15 MHz and 80 MHz  3 V/m 80 MHz to 2.7 GHz  See table 1</p>	<p>3 V<sub>rms</sub> 150 kHz to 80 MHz 6V<sub>rms</sub><sup>c</sup> in ISM bands between 0.15 MHz and 80 MHz  3 V/m 80 MHz to 2.7 GHz  Comply with table 1</p>	<p>Portable and mobile RF communications equipment should be used no closer to any part of the system, including cables, than the recommended separation distance calculated from the equation applicable to the frequency of the transmitter.</p> <p><b>Recommended separation distance</b></p> <p><math>d = 1.2\sqrt{P}</math> 150KHz to 80MHz  <math>d = 1.2\sqrt{P}</math> 80 MHz to 800 MHz  <math>d = 2.3\sqrt{P}</math> 800 MHz to 2.7 GHz  <math>d = 6\sqrt{P/E}</math> at RF wireless communications equipment bands (Portable RF communications equipment (including peripherals such as antenna cables and external antennas) should be used no closer than 30 cm (12 inches) to any part of the system, including cables specified by the manufacturer).</p> <p>Where P is the maximum output power rating of the transmitter in watts (W) according to the transmitter manufacturer and d is the recommended separation distance in meters (m).</p> <p>Field strengths from fixed RF transmitters, as determined by an electromagnetic site survey,<sup>a</sup> should be less than the compliance level in each frequency range.<sup>b</sup></p> <p>Interference may occur in the vicinity of equipment marked with the following symbol:</p> 

**NOTE 1** At 80 MHz and 800 MHz, the higher frequency range applies.

**NOTE 2** These guidelines may not apply in all situations. Electromagnetic propagation is affected by absorption and reflection from structures, objects and people.

<sup>a</sup> Field strengths from fixed transmitters, such as base stations for radio (cellular/cordless) telephones and land mobile radios, amateur radio, AM and FM radio broadcast and TV broadcast cannot be predicted theoretically with accuracy. To assess the electromagnetic environment due to fixed RF transmitters, an electromagnetic site survey should be considered. If the measured field strength in the location in which the system is used exceeds the applicable RF compliance level above, the system should be observed to verify normal operation. If abnormal performance is observed, additional measures may be necessary, such as reorienting or relocating the system.

<sup>b</sup> Over the frequency range 150kHz to 80MHz, field strengths should be less than 3V/m.

<sup>c</sup> The ISM (industrial, scientific and medical) bands between 0.15 MHz and 80 MHz are 6.765 MHz to 6.795 MHz; 13.553 MHz to 13.567 MHz; 26.957 MHz to 27.283 MHz; and 40.66 MHz to 40.70 MHz. The amateur radio bands between 0.15 MHz and 80 MHz are 1.8 MHz to 2.0 MHz, 3.5 MHz to 4.0 MHz, 5.3 MHz to 5.4 MHz, 7 MHz to 7.3 MHz, 10.1 MHz to 10.15 MHz, 14 MHz to 14.2 MHz, 18.07 MHz to 18.17 MHz, 21.0 MHz to 21.4 MHz, 24.89 MHz to 24.99 MHz, 28.0 MHz to 29.7 MHz and 50.0 MHz to 54.0 MHz.

**Table 1 Test specifications for ENCLOSURE PORT IMMUNITY to RF wireless communications equipment**

Test frequency (MHz)	Band <sup>a)</sup> (MHz)	Service <sup>a)</sup>	Modulation <sup>b)</sup>	Maximum power (W)	Distance (m)	Immunity test level (V/m)
385	380-390	TETRA 400	Pulse modulation <sup>b)</sup> 18 Hz	1.8	0.3	27
450	430-470	GMRS 460, FRS 460	FM <sup>c)</sup> ± 5 kHz deviation 1 kHz sine	2	0.3	28
710	704-787	LTE Band 13, 17	Pulse modulation <sup>b)</sup> 217 Hz	0.2	0.3	9
745						
780						
810	800-960	GSM 800/900, TETRA 800, iDEN 820, CDMA 850, LTE Band 5	Pulse modulation <sup>b)</sup> 18 Hz	2	0.3	28
870						
930						
1720	1700-1990	GSM 1800; CDMA 1900; GSM 1900; DECT; LTE Band 1, 3, 4, 25; UMTS	Pulse modulation <sup>b)</sup> 217 Hz	2	0.3	28
1845						
1970						



2450	2400-2570	Bluetooth, WLAN, 802.11 b/g/n, RFID 2450, LTE Band 7	Pulse modulation <sup>b)</sup> 217 Hz	2	0.3	28
5240	5100-5800	WLAN 802.11 a/n	Pulse modulation <sup>b)</sup> 217 Hz	0.2	0.3	9
5500						
5785						

NOTE If necessary to achieve the IMMUNITY TEST LEVEL, the distance between the transmitting antenna and the ME EQUIPMENT or ME SYSTEM may be reduced to 1 m. The 1 m test distance is permitted by IEC 61000-4-3.

- a) For some services, only the uplink frequencies are included.
- b) The carrier shall be modulated using a 50 % duty cycle square wave signal.
- c) As an alternative to FM modulation, 50 % pulse modulation at 18 Hz may be used because while it does not represent actual modulation, it would be worst case.

**Recommended Separation Distances**

**Recommended separation distances between portable and mobile RF communications equipment and the system**

The system is intended for use in an electromagnetic environment in which radiated RF disturbances are controlled. The customer or the user of the system can help prevent electromagnetic interference by maintaining a minimum distance between portable and mobile RF communications equipment (transmitters) and the system as recommended below, according to the maximum output power of the communications equipment.

Rated maximum output power of transmitter (W)	Separation distance according to frequency of transmitter(m)		
	150 kHz to 80 MHz $d = 1.2\sqrt{P}$	80 MHz to 800 MHz $d = 1.2\sqrt{P}$	800 MHz to 2.7 GHz $d = 2.3\sqrt{P}$
0.01	0.12	0.12	0.23
0.1	0.38	0.38	0.73
1	1.2	1.2	2.3
10	3.8	3.8	7.3
100	12	12	23

For transmitters rated at a maximum output power not listed above, the recommended separation distance d in meters (m) can be determined using the equation applicable to the frequency of the transmitter, where P is the maximum output power rating of the transmitter in watts (W) according to the transmitter manufacturer.

**NOTE 1:**At 80 MHz and 800 MHz, the separation distance for the higher frequency range applies.

**NOTE 2:**These guidelines may not apply in all situations. Electromagnetic propagation is affected by absorption and reflection from structures, objects and people.

P/N: 01.54.458126

MPN: 01.54.458126010



**EDAN INSTRUMENTS, INC.**

#15 Jinhui Road, Jinsha Community, Kengzi Sub-District  
Pingshan District, 518122 Shenzhen, P.R.China

Email: [info@edan.com.cn](mailto:info@edan.com.cn)

TEL: +86-755-2689 8326 FAX: +86-755-2689 8330

Website: [www.edan.com.cn](http://www.edan.com.cn)

**EC REPRESENTATIVE**

Shanghai International Holding Corp. GmbH

Eiffestrasse 80, 20537 Hamburg Germany

TEL: +49-40-2513175

E-mail: [shholding@hotmail.com](mailto:shholding@hotmail.com)