



TEST REPORT

Report Reference No...... : **TRE1403012402** **R/C**.....:**49068**
FCC ID..... : **SMQFTS3UEDAN**
Applicant's name..... : **Edan Instruments, Inc.**
Address..... : 3/F - B, Nanshan Medical Equipments Park, Nanhai Rd 1019#,
 Shekou, Nanshan Shenzhen,518067 P.R. China
Manufacturer..... : Edan Instruments, Inc.
Address..... : 3/F - B, Nanshan Medical Equipments Park, Nanhai Rd 1019#,
 Shekou, Nanshan Shenzhen,518067 P.R. China
Test item description : **Fetal Telemetry System**
Trade Mark : **EDAN**
Model/Type reference..... : **FHR Probe**
Listed Model(s) : /
Standard : **FCC CFR Title 47 Part 95H Wireless Medical Telemetry Service (WMTS)**
Date of receipt of test sample..... : Mar 19, 2014
Date of testing..... : Mar 19 ~ Oct 22, 2014
Date of issue..... : Oct 22, 2014
Result..... : **PASS**

Compiled by
 (position+printed name+signature)... : File administrators Any Yang

Any Yang

Supervised by
 (position+printed name+signature)... : Project Engineer Lion Cai

Lion Cai

Approved by
 (position+printed name+signature)... : RF Manager Hans Hu

Hans Hu

Testing Laboratory Name : **Shenzhen Huatongwei International Inspection Co., Ltd**
Address..... : Bldg3, Hongfa Hi-tech Industrial Park, Genyu Road, Shenzhen,
 China

Shenzhen Huatongwei International Inspection Co., Ltd. All rights reserved.

This publication may be reproduced in whole or in part for non-commercial purposes as long as the Shenzhen Huatongwei International Inspection Co., Ltd is acknowledged as copyright owner and source of the material. Shenzhen Huatongwei International Inspection Co., Ltd takes no responsibility for and will not assume liability for damages resulting from the reader's interpretation of the reproduced material due to its placement and context.

Contents

1.	<u>TEST STANDARDS AND TEST DESCRIPTION</u>	3
1.1.	Test Standards	3
1.2.	Test Description	3
2.	<u>SUMMARY</u>	4
2.1.	Client Information	4
2.2.	Product Description	4
2.3.	EUT operation mode	5
2.4.	EUT configuration	5
2.5.	Modifications	5
3.	<u>TEST ENVIRONMENT</u>	6
3.1.	Address of the test laboratory	6
3.2.	Test Facility	6
3.3.	Environmental conditions	7
3.4.	Statement of the measurement uncertainty	7
3.5.	Equipments Used during the Test	8
4.	<u>TEST CONDITIONS AND RESULTS</u>	9
4.1.	Conducted Emissions	9
4.2.	Occupied bandwidth	10
4.3.	Frequency stability	12
4.4.	Spurious Emission (radiated)	14
5.	<u>TEST SETUP PHOTOS OF THE EUT</u>	19
6.	<u>EXTERNAL AND INTERNAL PHOTOS OF THE EUT</u>	20

1. TEST STANDARDS AND TEST DESCRIPTION

1.1. Test Standards

The tests were performed according to following standards:

[FCC Rules 47 CFR Part 95](#): Title 47 of the Code of Federal Regulations; Chapter I Subpart H—Wireless Medical Telemetry Service (WMTS); Part 95 - Personal radio services

[FCC Rules 47 CFR Part 2](#): -FREQUENCY ALLOCATIONS AND RADIO TREATY MATTERS; GENERAL RULES AND REGULATIONS

1.2. Test Description

Test Item	Section in CFR 47	Result
Conducted Emissions	CFR Part 15.107(a)	N/A
Frequency stability	FCC 47 CFR § 2.1055 § 95.1115(e)	Pass
Occupied bandwidth	FCC 47 CFR § 2.1049 (1)	Pass
Radiated field strength and Field strength of spurious radiation	FCC 47 CFR § 2.1053/2.1046 § 95.1115(a)(b)	Pass

Remark: The measurement uncertainty is not included in the test result.

N/A:Mean's not application.

2. SUMMARY

2.1. Client Information

Applicant:	Edan Instruments, Inc.
Address:	3/F - B, Nanshan Medical Equipments Park, Nanhai Rd 1019#, Shekou, Nanshan Shenzhen,518067 P.R. China
Manufacturer:	Edan Instruments, Inc.
Address:	3/F - B, Nanshan Medical Equipments Park, Nanhai Rd 1019#, Shekou, Nanshan Shenzhen,518067 P.R. China

2.2. Product Description

Name of EUT	FTS-Fetal Telemetry System
Trade Mark:	EDAN
Model No.:	FHR Probe
Listed Model(s):	/
Power supply:	DC 3.7V From Internal Battery
Adapter information:	/
Modulation:	FSK
Operation frequency:	608MHz-614MHz
Channel number:	32
Channel separation:	180KHz
Antenna type:	Internal Antenna
Antenna gain:	0 dBi

Operation Frequency List:

Channel	Frequency (MHz)
01	608.20
02	608.38
03	608.56
:	:
16	610.90
:	:
30	613.42
31	613.60
32	613.78

Note:

In section 15.31(m), regards to the operating frequency range over 10 MHz, the Lowest frequency, the middle frequency, and the highest frequency of channel were selected to perform the test, please see the above gray bottom.

2.3. EUT operation mode

The worst-case channel is determined as the channel with the highest output power.

During emission tests the antenna orientations as X, Y, and Z were investigated to determine the worst-case. The outcome showed that X-orientation for Horizontal and Y-orientation for Vertical as the worst-case.

2.4. EUT configuration

The following peripheral devices and interface cables were connected during the measurement:

- - supplied by the manufacturer
- - supplied by the lab

<input type="radio"/>	Power Cable	Length (m) : /
		Shield : /
		Detachable : /
<input type="radio"/>	Multimeter	Manufacturer : /
		Model No. : /

2.5. Modifications

No modifications were implemented to meet testing criteria.

3. TEST ENVIRONMENT

3.1. Address of the test laboratory

Test Laboratory: Shenzhen Huatongwei International Inspection Co., Ltd
Address: Bldg3, Hongfa Hi-tech Industrial Park, Genyu Road, Shenzhen, China
Phone: 86-755-26715686 Fax: 86-755-26748089

3.2. Test Facility

The test facility is recognized, certified, or accredited by the following organizations:

CNAS-Lab Code: L1225

Shenzhen Huatongwei International Inspection Co., Ltd. has been assessed and proved to be in compliance with CNAS-CL01 Accreditation Criteria for Testing and Calibration Laboratories (identical to ISO/IEC 17025: 2005 General Requirements) for the Competence of Testing and Calibration Laboratories, Date of Registration: Mar. 01, 2012. Valid time is until February 28, 2015.

A2LA-Lab Cert. No. 2243.01

Shenzhen Huatongwei International Inspection Co., Ltd. EMC Laboratory has been accredited by A2LA for technical competence in the field of electrical testing, and proved to be in compliance with ISO/IEC 17025: 2005 General Requirements for the Competence of Testing and Calibration Laboratories and any additional program requirements in the identified field of testing. Valid time is until Sept 30, 2015.

FCC-Registration No.: 662850

Shenzhen Huatongwei International Inspection Co., Ltd. EMC Laboratory has been registered and fully described in a report filed with the FCC (Federal Communications Commission). The acceptance letter from the FCC is maintained in our files. Registration 662850, Renewal date Jul. 01, 2012, valid time is until Jun. 01, 2015.

FCC-Registration No.: 317478

Shenzhen Huatongwei International Inspection Co., Ltd. (Gongming EMC Laboratory) has been registered and fully described in a report filed with the FCC (Federal Communications Commission). The acceptance letter from the FCC is maintained in our files. Registration 317478, Renewal date July 18, 2014, valid time is until July. 18, 2017.

IC-Registration No.: 5377A

The 3m Alternate Test Site of Shenzhen Huatongwei International Inspection Co., Ltd. has been registered by Certification and Engineering Bureau of Industry Canada for the performance of radiated measurements with Registration No. 5377A on Dec. 31, 2013, valid time is until Dec. 31, 2016.

IC-Registration No.: 5377B

The 3m Alternate Test Site of Shenzhen Huatongwei International Inspection Co., Ltd. (Gongming EMC Laboratory) has been registered by Certification and Engineering Bureau of Industry Canada for the performance of radiated measurements with Registration No. 5377B on September 3, 2014, valid time is until September 3, 2017.

ACA

Shenzhen Huatongwei International Inspection Co., Ltd. EMC Laboratory can also perform testing for the Australian C-Tick mark as a result of our A2LA accreditation.

VCCI

The 3m Semi-anechoic chamber (12.2m×7.95m×6.7m) of Shenzhen Huatongwei International Inspection Co., Ltd. has been registered in accordance with the Regulations for Voluntary Control Measures with Registration No.:R-2484. Date of Registration: Dec. 20, 2012. Valid time is until Dec. 29, 2015.

Radiated disturbance above 1GHz measurement of Shenzhen Huatongwei International Inspection Co., Ltd. has been registered in accordance with the Regulations for Voluntary Control Measures with Registration No.: G-292. Date of Registration: Dec. 24, 2013. Valid time is until Dec. 23, 2016.

Main Ports Conducted Interference Measurement of Shenzhen Huatongwei International Inspection Co., Ltd. has been registered in accordance with the Regulations for Voluntary Control Measures with Registration No.: C-2726. Date of Registration: Dec. 20, 2012. Valid time is until Dec. 19, 2015.

Telecommunication Ports Conducted Interference Measurement of Shenzhen Huatongwei International Inspection Co., Ltd. has been registered in accordance with the Regulations for Voluntary Control Measures with Registration No.: T-1837. Date of Registration: May 07, 2013. Valid time is until May 06, 2016.

DNV

Shenzhen Huatongwei International Inspection Co., Ltd. has been found to comply with the requirements of DNV towards subcontractor of EMC and safety testing services in conjunction with the EMC and Low voltage Directives and in the voluntary field. The acceptance is based on a formal quality Audit and follow-ups according to relevant parts of ISO/IEC Guide 17025 (2005), in accordance with the requirements of the DNV Laboratory Quality Manual towards subcontractors. Valid time is until Aug. 24, 2016.

3.3. Environmental conditions

During the measurement the environmental conditions were within the listed ranges:

Temperature:	15~35°C
Relative Humidity:	30~60 %
Air Pressure:	950~1050mba

3.4. Statement of the measurement uncertainty

The data and results referenced in this document are true and accurate. The reader is cautioned that there may be errors within the calibration limits of the equipment and facilities. The measurement uncertainty was calculated for all measurements listed in this test report acc. to TR-100028-01 "Electromagnetic compatibility and Radio spectrum Matters (ERM);Uncertainties in the measurement of mobile radio equipment characteristics;Part 1" and TR-100028-02 "Electromagnetic compatibilityand Radio spectrum Matters (ERM);Uncertainties in the measurementof mobile radio equipment characteristics;Part 2 " and is documented in the Shenzhen Huatongwei International Inspection Co., Ltd quality system acc. to DIN EN ISO/IEC 17025. Furthermore, component and process variability of devices similar to that tested may result in additional deviation. The manufacturer has the sole responsibility of continued compliance of the device.

Hereafter the best measurement capability for Shenzhen Huatongwei laboratory is reported:

Test Items	Measurement Uncertainty	Notes
Transmitter power conducted	0.57 dB	(1)
Transmitter power Radiated	2.20 dB	(1)
Conducted spurious emission 9KHz-40 GHz	1.60 dB	(1)
Radiated spurious emission 9KHz-40 GHz	2.20 dB	(1)
Conducted Emission 9KHz-30MHz	3.39 dB	(1)
Radiated Emission 30~1000MHz	4.24 dB	(1)
Radiated Emission 1~18GHz	5.16 dB	(1)
Radiated Emission 18-40GHz	5.54 dB	(1)
Occupied Bandwidth	-----	(1)

(1) This uncertainty represents an expanded uncertainty expressed at approximately the 95% confidence level using a coverage factor of k=1.96.

3.5. Equipments Used during the Test

AC Power Conducted Emission					
Item	Test Equipment	Manufacturer	Model No.	Serial No.	Cal Due
1	Artificial Mains	Rohde&Schwarz	ESH2-Z5	100028	2014/10/25
2	EMI Test Receiver	Rohde&Schwarz	ESCI3	100038	2014/10/25
3	Pulse Limiter	Rohde&Schwarz	ESHSZ2	100044	2014/10/25
4	EMI Test Software	Rohde&Schwarz	ES-K1 V1.71	N/A	N/A

Radiated Emission					
Item	Test Equipment	Manufacturer	Model No.	Serial No.	Cal Due
1	Ultra-Broadband Antenna	ShwarzBeck	VULB9163	538	2014/10/25
2	EMI TEST RECEIVER	Rohde&Schwarz	ESI 26	100009	2014/10/25
3	EMI TEST Software	Audix	E3	N/A	N/A
4	TURNTABLE	ETS	2088	2149	N/A
5	ANTENNA MAST	ETS	2075	2346	N/A
6	EMI TEST Software	Rohde&Schwarz	ESK1	N/A	N/A
7	HORN ANTENNA	ShwarzBeck	9120D	1011	2014/10/25
8	Amplifer	Sonoma	310N	E009-13	2014/10/25
9	JS amplifer	Rohde&Schwarz	JS4-00101800-28-5A	F201504	2014/10/25
10	High pass filter	Compliance Direction systems	BSU-6	34202	2014/10/25
11	HORN ANTENNA	ShwarzBeck	9120D	1012	2014/10/25
12	Amplifer	Compliance Direction systems	PAP1-4060	120	2014/10/25
13	Loop Antenna	Rohde&Schwarz	HFH2-Z2	100020	2014/10/25
14	TURNTABLE	MATURO	TT2.0	----	N/A
15	ANTENNA MAST	MATURO	TAM-4.0-P	----	N/A
16	Horn Antenna	SCHWARZBECK	BBHA9170	25841	2014/10/25
17	ULTRA-BROADBAND ANTENNA	Rohde&Schwarz	HL562	100015	2014/10/25

Maximum Peak Output Power / Power Spectral Density / 6dB Bandwidth / Band Edge Compliance of RF Emission / Spurious RF Conducted Emission					
Item	Test Equipment	Manufacturer	Model No.	Serial No.	Cal Due
1	Spectrum Analyzer	Rohde&Schwarz	FSP	1164.4391.40	2014/10/25
2	Power Meter	Anritsu	MA2411B	100258	2014/10/25

The Cal.Interval was one year

4. TEST CONDITIONS AND RESULTS

4.1. Conducted Emissions

LIMIT:

Frequency of Emission (MHz)	Conducted Limit (dBuV)	
	Quasi-peak	Average
0.15-0.5	66 to 56 *	56 to 46 *
0.5-5	56	46
5-30	60	50

* Decreasing linearly with the logarithm of the frequency

TEST CONFIGURATION

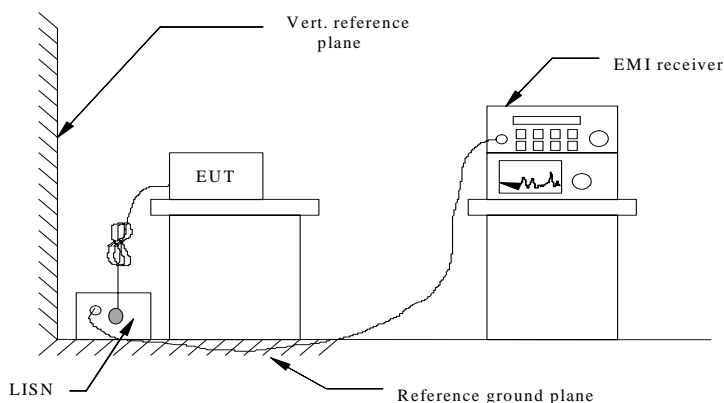

TEST PROCEDURE

- 1 The equipment was set up as per the test configuration to simulate typical actual usage per the user's manual. The EUT is a tabletop system; a wooden table with a height of 0.8 meters is used and is placed on the ground plane as per ANSI C63.4-2009.
- 2 Support equipment, if needed, was placed as per ANSI C63.4-2009.
- 3 All I/O cables were positioned to simulate typical actual usage as per ANSI C63.4-2009.
- 4 If a EUT received DC power from the adapter, the adapter received AC120V/60Hz power through a Line Impedance Stabilization Network (LISN) which supplied power source and was grounded to the ground plane.
- 5 All support equipments received AC power from a second LISN, if any.
- 6 The EUT test program was started. Emissions were measured on each current carrying line of the EUT using a spectrum Analyzer / Receiver connected to the LISN powering the EUT. The LISN has two monitoring points: Line 1 (Hot Side) and Line 2 (Neutral Side). Two scans were taken: one with Line 1 connected to Analyzer / Receiver and Line 2 connected to a 50 ohm load; the second scan had Line 1 connected to a 50 ohm load and Line 2 connected to the Analyzer / Receiver.
- 7 Analyzer / Receiver scanned from 150 KHz to 30MHz for emissions in each of the test modes.
- 8 During the above scans, the emissions were maximized by cable manipulation.

TEST RESULTS

Not Application.

4.2. Occupied bandwidth

LIMIT

§2.1049, for reporting purposes only,

TEST CONFIGURATION



TEST PROCEDURE

1. The EUT was tested according to ANSI C63.4: 2009 requirements.
2. The transmitter output is connected to the spectrum analyze
3. The RBW is set to 1% to 3% of the 99 % bandwidth.
 The VBW is set to 3 times the RBW.
 The sweep time is coupled.
 The spectrum analyzer internal 99% bandwidth function is utilized.

TEST RESULTS

Channel	99% Occupied Bandwidth(KHz)
01	43.60
16	39.80
32	40.50

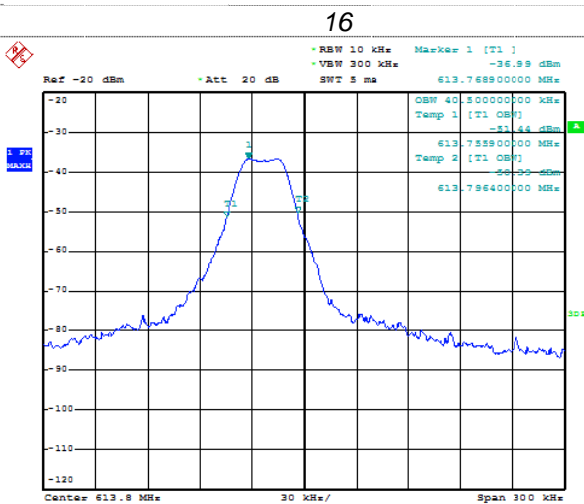
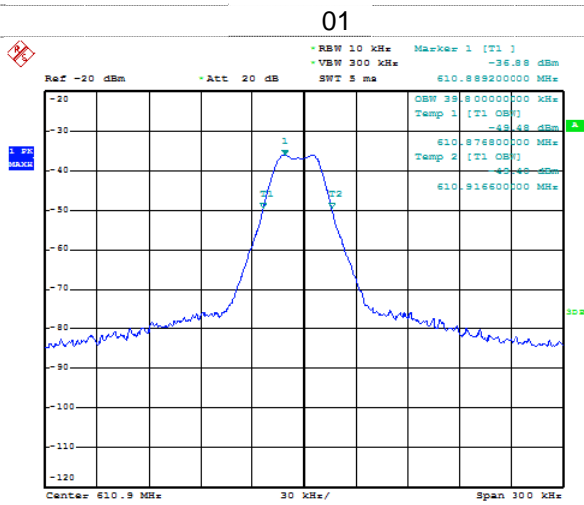
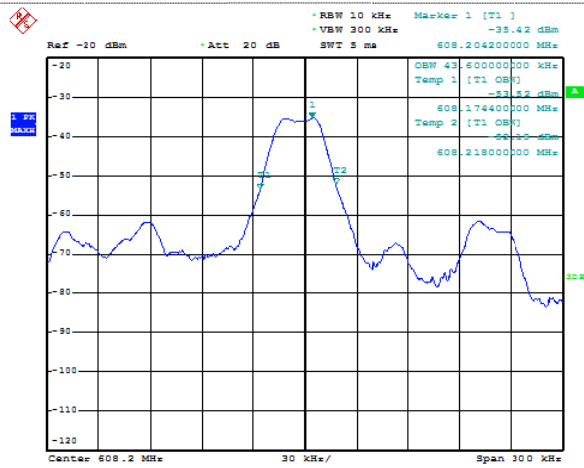

4.3. Frequency stability

LIMIT

§95.115 (e) Frequency stability.

Manufacturers of wireless medical telemetry devices are responsible for ensuring frequency stability such that an emission is maintained within the band of operation under all of the manufacturer's specified conditions.

TEST CONFIGURATION

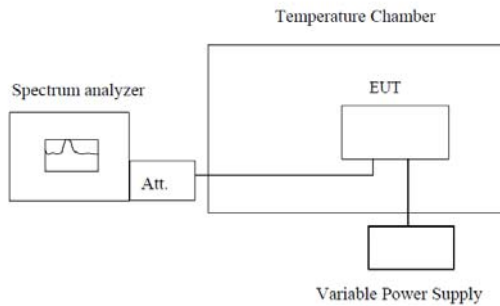

Note : Measurement setup for testing on Antenna connector

TEST PROCEDURE

Frequency stability versus environmental temperature

1. The equipment under test was connected to an external DC power supply and input rated voltage.
2. RF output was connected to a frequency counter or spectrum analyzer via feed through attenuators.
3. The EUT was placed inside the temperature chamber.
4. Set the spectrum analyzer RBW low enough to obtain the desired frequency resolution and measure EUT 25°C operating frequency as reference frequency.
5. Turn EUT off and set the chamber temperature to -30°C. After the temperature stabilized for approximately 30 minutes recorded the frequency.
6. Repeat step measure with 10°C increased per stage until the highest temperature of +50°C reached.

Frequency stability versus input voltage

1. Set chamber temperature to 25°C. Use a variable DC power source to power the EUT and set the voltage to rated voltage.
2. Set the spectrum analyzer RBW low enough to obtain the desired frequency resolution and recorded the frequency.
3. Reduce the input voltage to specified extreme voltage variation (+/- 10%) and endpoint, record the maximum frequency change.

TEST RESULTS

Low Channle

Temperature	Deviation (kHz)	Emission within band
-20 °C	-0.14	Yes
-10 °C	-0.17	Yes
0 °C	-0.15	Yes
10 °C	-0.18	Yes
20 °C (V nom)	-0.14	Yes
30 °C	-0.18	Yes
40 °C	-0.19	Yes
55 °C	-0.20	Yes
Voltage		
90 %	-0.18	Yes
110 %	-0.17	Yes

High Channle

Temperature	Deviation (kHz)	Emission within band
-20 °C	-0.16	Yes
-10 °C	-0.17	Yes
0 °C	-0.15	Yes
10 °C	-0.14	Yes
20 °C (V nom)	-0.18	Yes
30 °C	-0.15	Yes
40 °C	-0.14	Yes
55 °C	-0.18	Yes
Voltage		
90 %	-0.17	Yes
110 %	-0.15	Yes

4.4. Spurious Emission (radiated)

LIMIT

(a) Field strength limits

(1) In the 608–614 MHz band, the maximum allowable field strength is 200 mV/m, as measured at a distance of 3 meters, using measuring instrumentation with a CISPR quasi-peak detector.

(b) Undesired emissions.

(1) Out-of-band emissions below 960 MHz are limited to 200 microvolts/meter, as measured at a distance of 3 meters, using measuring instrumentation with a CISPR quasi-peak detector.

(2) Out-of-band emissions above 960 MHz are limited to 500 microvolts/meter as measured at a distance of 3 meters, using measuring equipment with an averaging detector and a 1 MHz measurement bandwidth.

TEST CONFIGURATION

- Below 1GHz

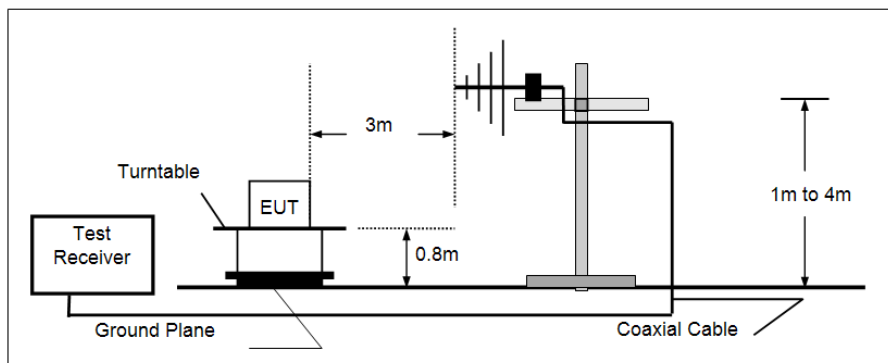

- Above 1GHz

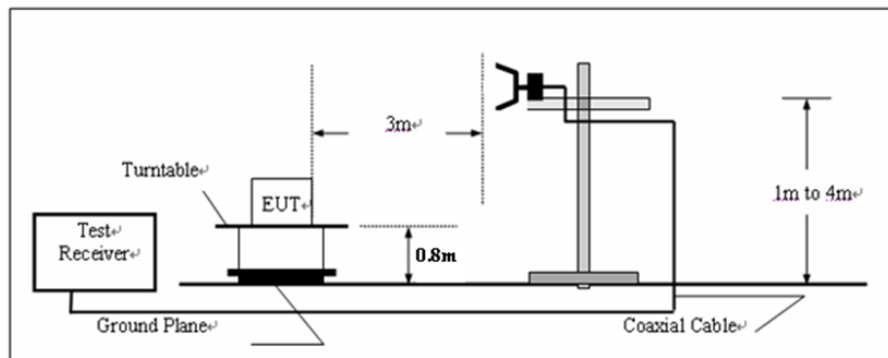

TEST PROCEDURE

1. The EUT was setup according to ANSI C63.4: 2009/ ANSI C63.19-2011 and tested according to ANSI C63.19-2011 / ANSI TIA-603-C-2004.
2. The EUT is placed on a turn table which is 0.8 meter above ground. The turn table is rotated 360 degrees to determine the position of the maximum emission level.
3. The EUT was positioned such that the distance from antenna to the EUT was 3 meters.
4. The antenna is scanned from 1 meter to 4 meters to find out the maximum emission level. This is repeated for both horizontal and vertical polarization of the antenna. In order to find the maximum emission, all of the interface cables were manipulated according to ANSI C63.4:2009 on radiated measurement.
5. The resolution bandwidth below 1GHz setting on the field strength meter is 120 kHz and above 1GHz is 1MHz.
6. For Frequencies below 1 GHz, RBW= 120 kHz, testing was performed with CISPR16 compliant test receiver with QP detector. Above 1 GHz tests were performed using a spectrum analyser using the following settings:
Peak RBW=VBW= 1MHz ,Peak detector
Average RBW 1MHz , VBW=10Hz,Peak detector

7. These settings as per ANSI TIA-603-C-2004

The unit was placed in hopped stopped mode at Low, Mid and High Channel. The fundamental frequency was maximized, and a QP measurement was taken.

TEST RESULTS

For fundamental emission

QP value:

Channel	Frequency (MHz)	Read Level (dBuV)	Antenna Factor (dB/m)	Cable Loss (dB)	Preamp Factor (dB)	Level (dBuV/m)	Limit Line (dBuV/m)	Margin Limit (dB)	Polarization
CH01	608.20	96.82	17.59	2.90	28.75	88.56	106.00	-17.44	Vertical
	608.20	95.04	17.59	2.90	28.75	86.78	106.00	-19.22	Horizontal
CH16	610.90	97.02	17.59	3.00	28.92	88.69	106.00	-17.31	Vertical
	610.90	95.92	17.59	3.00	28.92	87.59	106.00	-18.41	Horizontal
CH32	613.78	94.78	17.59	3.12	28.62	86.87	106.00	-19.13	Vertical
	613.78	95.50	17.59	3.12	28.62	87.59	106.00	-18.41	Horizontal

For 9KHz to 30MHz

Frequency (MHz)	Level (dBuV/m)@3m	Limit Line (dBuV/m)@3m	Margin (dB)	Detector	Result
13.25	41.57	69.54	-27.97	QP	PASS
24.74	41.58	69.54	-27.96	QP	PASS

Test channel:	01
---------------	----

Peak value:

Frequency (MHz)	Read Level (dBuV)	Antenna Factor (dB/m)	Cable Loss (dB)	Preamp Factor (dB)	Level (dBuV/m)	Limit Line (dBuV/m)	Margin Limit (dB)	Detector	Polarization
112.89	37.51	12.43	1.12	28.54	22.52	46.00	-23.48	QP	Vertical
232.74	43.80	10.19	1.68	28.82	26.85	46.00	-19.15	QP	Vertical
1216.40	47.58	24.57	4.58	36.54	40.19	74.00	-33.81	PK	Vertical
1824.60	52.26	25.58	5.86	37.12	46.58	74.00	-27.42	PK	Vertical
2432.80	49.06	27.40	6.89	37.61	45.74	74.00	-28.26	PK	Vertical
*						74.00		PK	Vertical
112.89	39.55	12.43	1.12	28.54	24.56	46.00	-21.44	QP	Horizontal
232.74	16.55	36.38	7.08	35.32	24.69	46.00	-21.31	QP	Horizontal
1216.40	57.15	24.57	4.58	36.54	49.76	74.00	-24.24	PK	Horizontal
1824.60	53.53	25.58	5.86	37.12	47.85	74.00	-26.15	PK	Horizontal
2432.80	45.01	27.40	6.89	37.61	41.69	74.00	-32.31	PK	Horizontal
*						74.00	*	PK	Horizontal

Average value:

Frequency (MHz)	Read Level (dBuV)	Antenna Factor (dB/m)	Cable Loss (dB)	Preamp Factor (dB)	Level (dBuV/m)	Limit Line (dBuV/m)	Margin Limit (dB)	Detector	Polarization
1216.40	44.64	24.57	4.58	36.54	37.25	54.00	-16.75	AVG	Vertical
1824.60	51.55	25.58	5.86	37.12	45.87	54.00	-8.13	AVG	Vertical
2432.80	46.01	27.40	6.89	37.61	42.69	54.00	-11.31	AVG	Vertical
*						54.00		AVG	Vertical
1216.40	52.17	24.57	4.58	36.54	44.78	54.00	-9.22	AVG	Horizontal
1824.60	49.37	25.58	5.86	37.12	43.69	54.00	-10.31	AVG	Horizontal
2432.80	39.21	27.40	6.89	37.61	35.89	54.00	-18.11	AVG	Horizontal
*						54.00	*	AVG	Horizontal

Remark:

1. Final Level = Receiver Read level + Antenna Factor + Cable Loss – Pre-amplifier Factor
2. “*”, means this data is the too weak instrument of signal is unable to test.
3. The emission levels of other frequencies are very lower than the limit and not show in test report.

Test channel:	16
---------------	----

Peak value:

Frequency (MHz)	Read Level (dBuV)	Antenna Factor (dB/m)	Cable Loss (dB)	Preamp Factor (dB)	Level (dBuV/m)	Limit Line (dBuV/m)	Margin Limit (dB)	Detector	Polarization
114.74	38.65	12.43	1.12	28.56	23.64	46.00	-22.36	QP	Vertical
236.78	43.62	10.21	1.69	28.94	26.58	46.00	-19.42	QP	Vertical
1221.80	49.15	24.57	4.60	36.58	41.74	74.00	-32.26	PK	Vertical
1832.70	53.60	25.58	5.90	37.23	47.85	74.00	-26.15	PK	Vertical
2443.60	48.91	27.40	6.91	37.64	45.58	74.00	-28.42	PK	Vertical
*						74.00		PK	Vertical
114.74	38.37	12.43	1.12	28.56	23.36	46.00	-22.64	QP	Horizontal
236.78	40.79	10.21	1.69	28.94	23.75	46.00	-22.25	QP	Horizontal
1221.80	57.19	24.57	4.60	36.58	49.78	74.00	-24.22	PK	Horizontal
1832.70	52.00	25.58	5.90	37.23	46.25	74.00	-27.75	PK	Horizontal
2443.60	45.17	27.40	6.91	37.64	41.84	74.00	-32.16	PK	Horizontal
*						74.00	*	PK	Horizontal

Average value:

Frequency (MHz)	Read Level (dBuV)	Antenna Factor (dB/m)	Cable Loss (dB)	Preamp Factor (dB)	Level (dBuV/m)	Limit Line (dBuV/m)	Margin Limit (dB)	Detector	Polarization
1221.80	43.99	24.57	4.60	36.58	36.58	54.00	-17.42	AVG	Vertical
1832.70	50.53	25.58	5.90	37.23	44.78	54.00	-9.22	AVG	Vertical
2443.60	44.89	27.40	6.91	37.64	41.56	54.00	-12.44	AVG	Vertical
*						54.00		AVG	Vertical
1221.80	53.27	24.57	4.60	36.58	45.86	54.00	-8.14	AVG	Horizontal
1832.70	48.22	25.58	5.90	37.23	42.47	54.00	-11.53	AVG	Horizontal
2443.60	39.02	27.40	6.91	37.64	35.69	54.00	-18.31	AVG	Horizontal
*						54.00	*	AVG	Horizontal

Remark:

1. Final Level = Receiver Read level + Antenna Factor + Cable Loss – Pre-amplifier Factor
2. “*”, means this data is the too weak instrument of signal is unable to test.
3. The emission levels of other frequencies are very lower than the limit and not show in test report.

Test channel:	32
---------------	----

Peak value:

Frequency (MHz)	Read Level (dBuV)	Antenna Factor (dB/m)	Cable Loss (dB)	Preamp Factor (dB)	Level (dBuV/m)	Limit Line (dBuV/m)	Margin Limit (dB)	Detector	Polarization
113.64	39.63	12.48	1.12	28.58	24.65	46.00	-21.35	QP	Vertical
235.52	42.39	10.15	1.69	28.87	25.36	46.00	-20.64	QP	Vertical
1227.56	47.52	24.57	4.71	36.56	40.24	74.00	-33.76	PK	Vertical
1841.34	54.46	25.58	5.92	37.18	48.78	74.00	-25.22	PK	Vertical
2455.12	49.01	27.40	6.93	37.65	45.69	74.00	-28.31	PK	Vertical
*						74.00		PK	Vertical
113.62	37.50	12.48	1.12	28.58	22.52	46.00	-23.48	QP	Horizontal
235.64	40.46	10.15	1.69	28.87	23.43	46.00	-22.57	QP	Horizontal
1227.56	57.17	24.57	4.71	36.56	49.89	74.00	-24.11	PK	Horizontal
1841.34	52.91	25.58	5.92	37.18	47.23	74.00	-26.77	PK	Horizontal
2455.12	45.06	27.40	6.93	37.65	41.74	74.00	-32.26	PK	Horizontal
*						74.00	*	PK	Horizontal

Average value:

Frequency (MHz)	Read Level (dBuV)	Antenna Factor (dB/m)	Cable Loss (dB)	Preamp Factor (dB)	Level (dBuV/m)	Limit Line (dBuV/m)	Margin Limit (dB)	Detector	Polarization
1227.56	43.64	24.57	4.71	36.56	36.36	54.00	-17.64	AVG	Vertical
1841.34	51.13	25.58	5.92	37.18	45.45	54.00	-8.55	AVG	Vertical
2455.12	44.84	27.40	6.93	37.65	41.52	54.00	-12.48	AVG	Vertical
*						54.00		AVG	Vertical
1227.56	52.92	24.57	4.71	36.56	45.64	54.00	-8.36	AVG	Horizontal
1841.34	49.41	25.58	5.92	37.18	43.73	54.00	-10.27	AVG	Horizontal
2455.12	37.57	27.40	6.93	37.65	34.25	54.00	-19.75	AVG	Horizontal
*						54.00	*	AVG	Horizontal

Remark:

1. Final Level = Receiver Read level + Antenna Factor + Cable Loss – Pre-amplifier Factor
2. “*”, means this data is the too weak instrument of signal is unable to test.
3. The emission levels of other frequencies are very lower than the limit and not show in test report.

5. Test Setup Photos of the EUT

Radiated Emission (30MHz-1GHz)

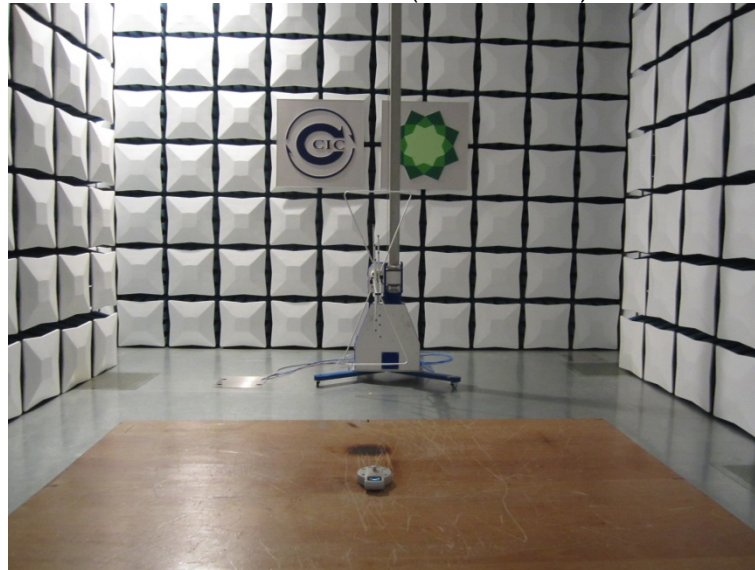

Radiated Emission (above 1GHz)

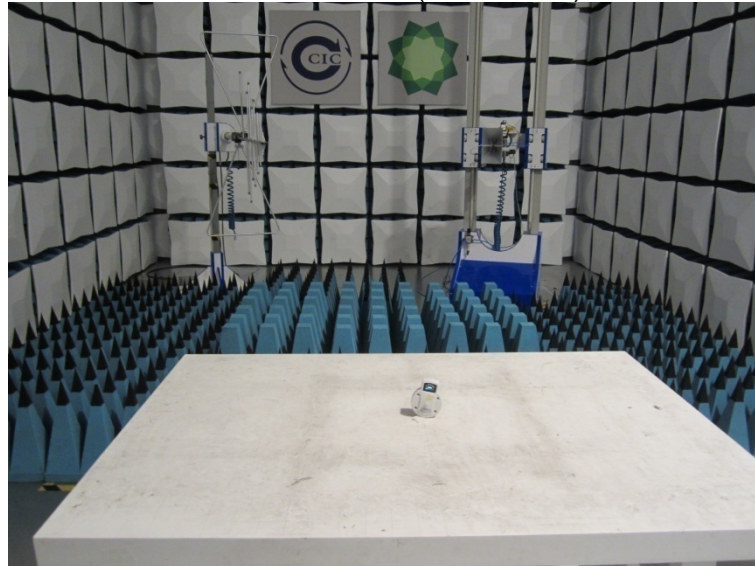

6. External and Internal Photos of the EUT

External photos of the EUT





Internal photos of the EUT

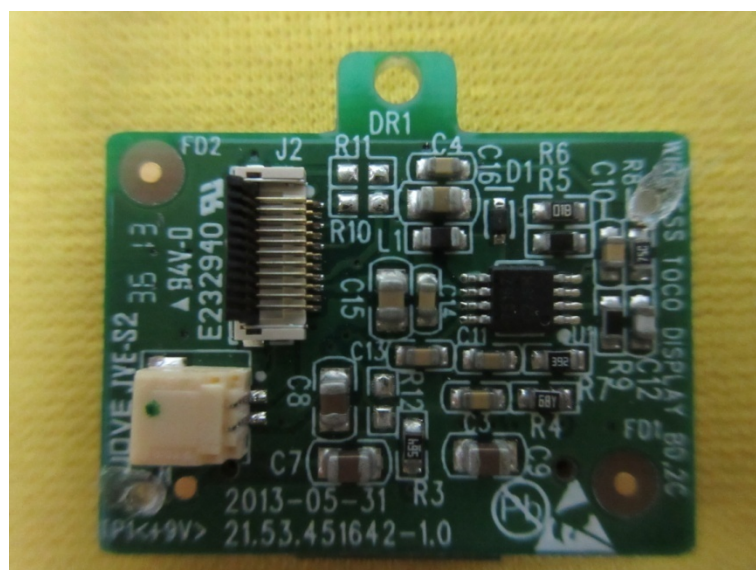

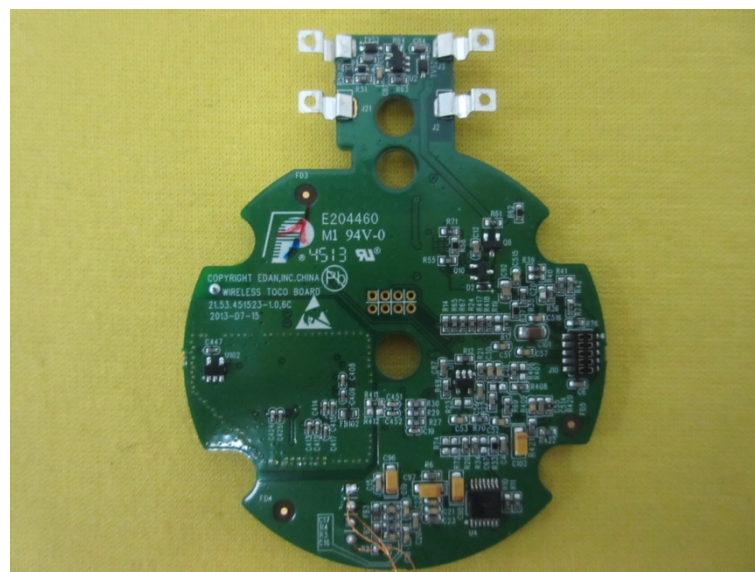
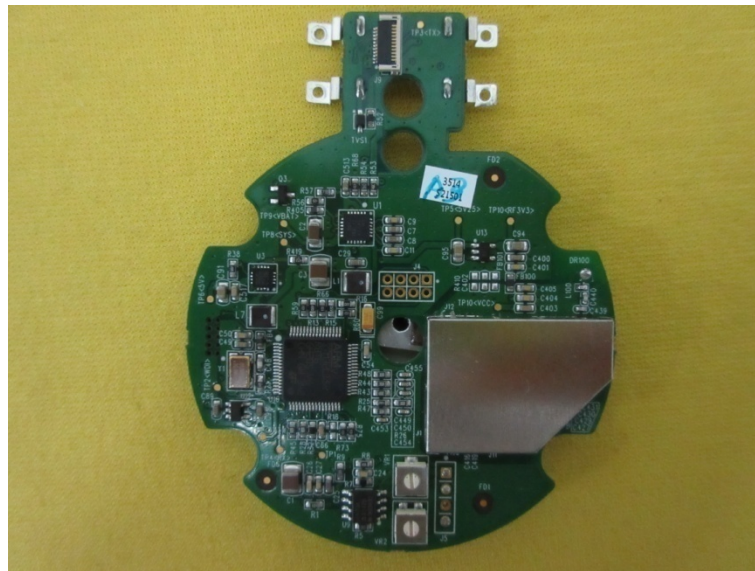
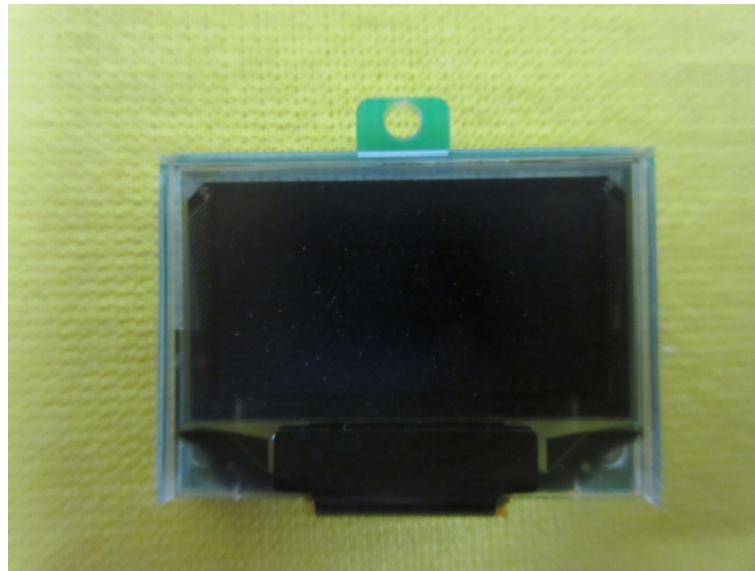



.....End of Report.....