

REVISIONS			
REV	DESCRIPTION	DATE	APPROVED
100	RELEASED PER ECN090010	06/09/09	

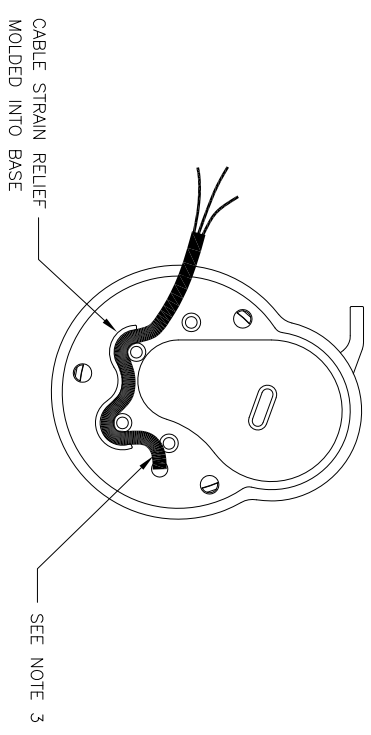

BASE-TOP VIEW

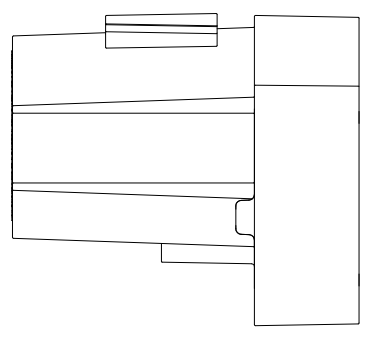
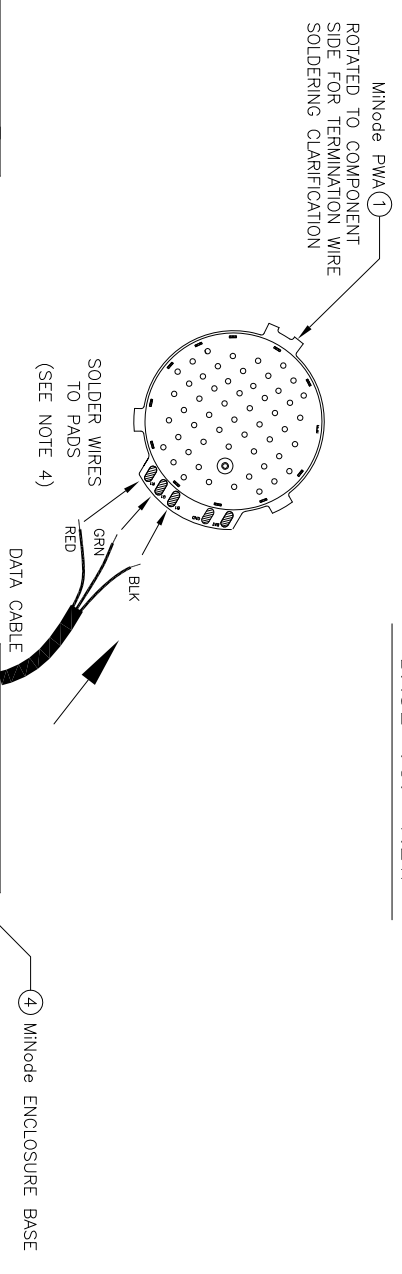

BASE-LEFT SIDE VIEW

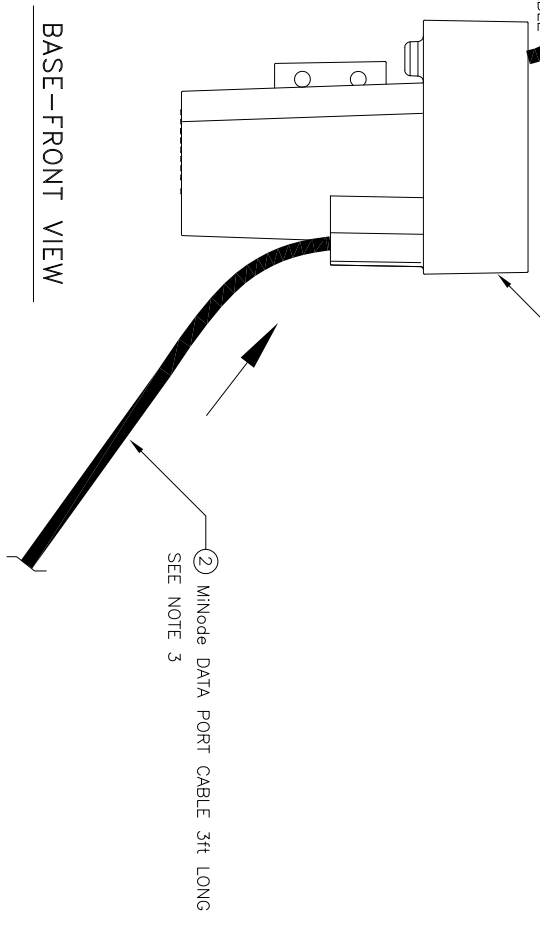

BASE-FRONT VIEW

NOTES: UNLESS OTHERWISE SPECIFIED

- 1) THIS IS A STATIC SENSITIVE ASSEMBLY- USE STATIC ELIMINATING MEASURES DURING ASSEMBLY AND HANDLING.
- 2) MANUFACTURE TO IPC 610A CLASS 2 WORKMANSHIP STANDARDS

MINode ENCLOSURE ASSEMBLY INSTRUCTIONS

- 3) PLACE THE ENCLOSURE BASE (ITEM4) ON A FLAT SURFACE AND INSERT THE DATA PORT CABLE (ITEM2) THRU THE HOLE ON THE RIGHT SIDE & RUN IT THROUGH THE STRAIN RELIEF MOLDED INTO THE ENCLOSURE AS SHOWN IN THE TOP VIEW. BE SURE TO LEAVE ABOUT 1 INCH OF CABLE SLACK HANGING OUT THE TOP.
- 4) SOLDER THE 3 WIRES OF THE DATA PORT CABLE TO THE CONTACT PADS OF THE MINode PWA (ITEM1). INSERT THE WIRE INTO THE HOLES FROM THE COMPONENT SIDE AND SOLDER IN PLACE PER DIAGRAM AS FOLLOWS:
 - FROM THE BLACK WIRE TO THE "B1" PAD ON MINode PWA
 - FROM THE GREEN WIRE TO THE "G1" PAD ON MINode PWA
 - FROM THE RED WIRE TO THE "R1" PAD ON MINode PWA

INSTRUCTIONS CONTINUED ON SHEET 2

FOR PRODUCT STRUCTURE SEE 890-0024-003

MUELLER SYSTEMS CONFIDENTIAL

THIS DRAWING CONTAINS INFORMATION OF A CONFIDENTIAL AND/OR PROPRIETARY NATURE. IT IS TO BE KEPT SECRET AND NOT DISCLOSED, REPRODUCED, COPIED, OR IN ANY MANNER MADE PUBLIC WITHOUT THE EXPRESS WRITTEN CONSENT OF MUELLER.

DWG file: 895-0024-003-1_A00

UNLESS OTHERWISE SPECIFIED, ALL DIMENSIONS ARE IN INCHES OR IN [MILLIMETERS]

TOLERANCES	
DECIMALS	ANGLES
X ± .03	± 1/2°
.XX ± .01	
.XXX ± .005	

MATERIAL	
FINISH	

APPROVALS		DATE
DRAWN BY:	M/FLM	06/05/09
CHECKED BY:		
APPROVED BY:		

Mueller Systems

TITLE
ASSY & MODIFICATION DWG
MINode-WATER (1 PORT HI)
WITH 3 FT WIRE

SIZE	PART NO.	REV.
D	895-0024-003	100

SCALE 1:1 DO NOT SCALE DRAWING SHEET 1 OF 3

REVISIONS			
REV	DESCRIPTION	DATE	APPROVED
1	SEE SHEET 1 FOR REVISIONS		

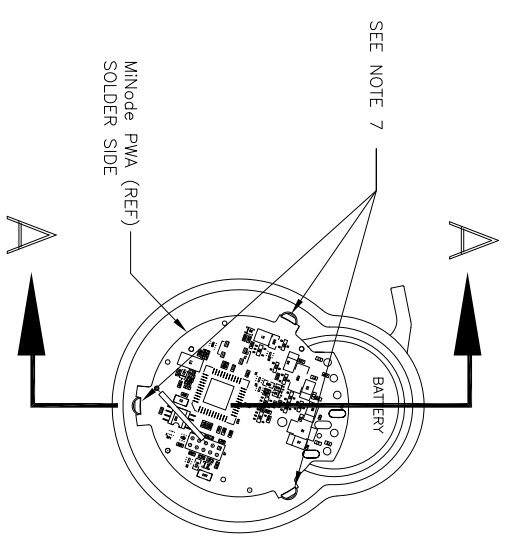

PWA INSTALL -TOP VIEW

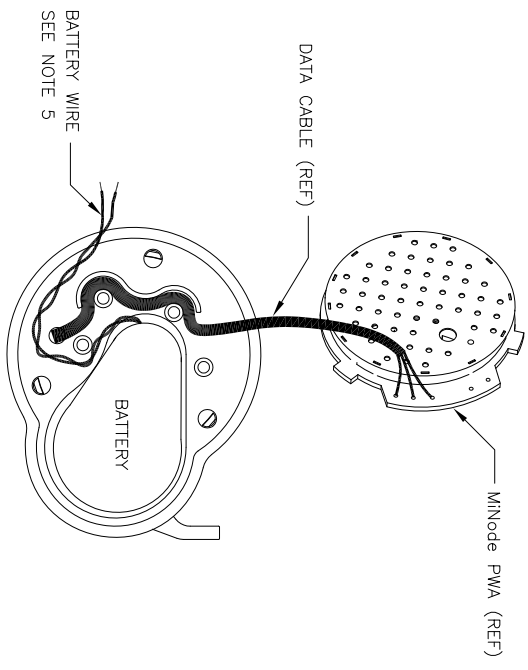

BATTERY INSTALL-TOP VIEW

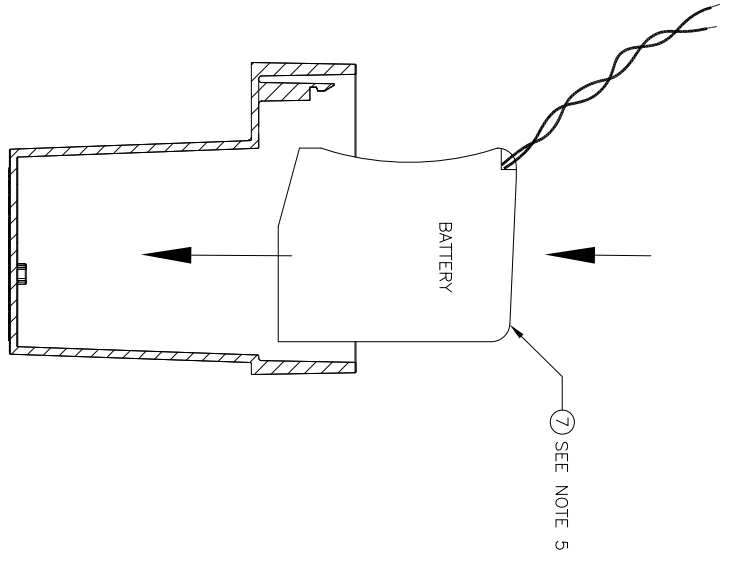

BATTERY INSTALLATION
(ROTATED TO SIDE VIEW FOR CLARITY)

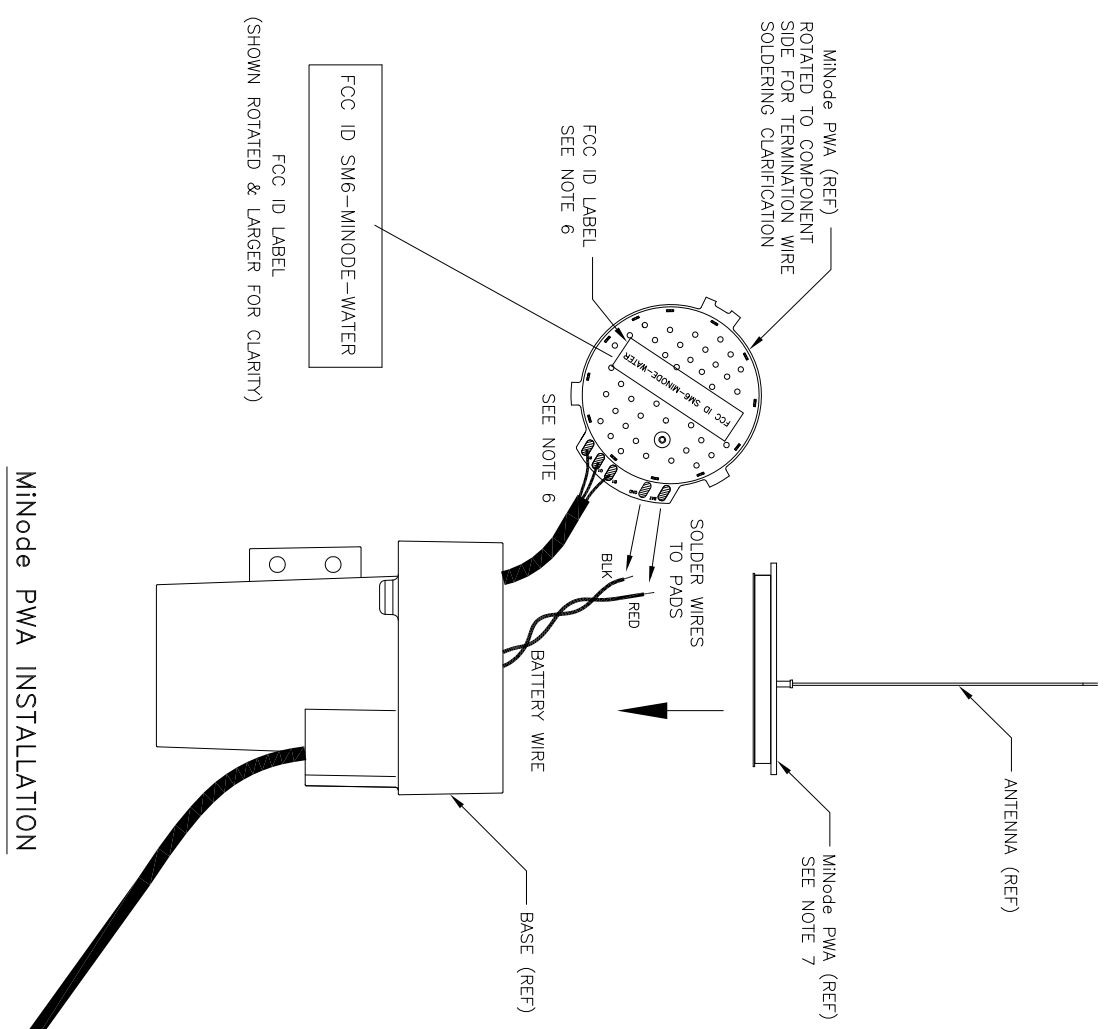

MINode PWA INSTALLATION

- MINode ASSEMBLY INSTRUCTIONS – CONT FOM SHT 1
- 5) INSTALL THE BATTERY (ITEM7) INTO THE BASE AS SHOWN AND LEAVE THE BATTERY WIRES HANGING OUT OF THE ENCLOSURE.
 - 6) ONCE THE BATTERY IS IN PLACE, SOLDER THE WIRES TO THE PADS OF THE MINode MODULE. INSERT THE WIRE INTO THE HOLES FROM THE COMPONENT SIDE AND SOLDER IN PLACE PER DIAGRAM AS FOLLOWS:
 - FROM THE BLACK WIRE TO THE "GND" PAD ON MINode PWA
 - FROM THE RED WIRE TO THE "BAT" PAD ON MINode PWA
 ONCE COMPLETE, APPLY A LABEL WITH THE FCC PART 15 ID NUMBER ON TOP OF THE SHIELD IN THE APPROX AREA SHOWN. THIS IS THE SAME NUMBER REFERENCED ON THE BOTTOM OF THE ENCLOSURE BASE.
 - 7) ONCE THE BATTERY WIRES ARE SOLDERED, ROTATE THE MINode MODULE SO THAT THE SHIELD IS FACING TOWARDS THE BATTERY & THE ANTENNA IS FACING UPWARDS. LINE UP THE 3 TABS OF THE ASSEMBLY WITH THE 3 LOCKING CLIPS OF THE BASE AND INSERT DOWN IN PLACE (SEE TOP VIEW). MOVE THE WIRES OF BATTERY AND THE DATA CABLE SO THAT THEY DON'T INTERFERE WITH THE INSTALLATION.

INSTRUCTIONS CONTINUED ON SHEET 3

REVISIONS			
REV	DESCRIPTION	DATE	APPROVED
1	SEE SHEET 1 FOR REVISIONS		

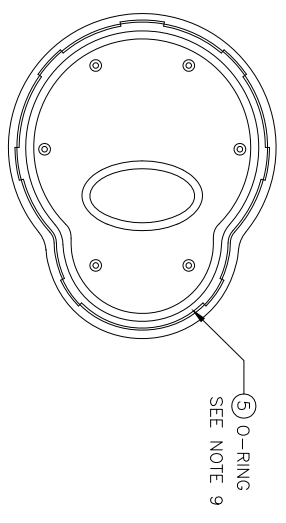

③ O-RING
SEE NOTE 9

VIEW B-B
O-RING INSTALLATION

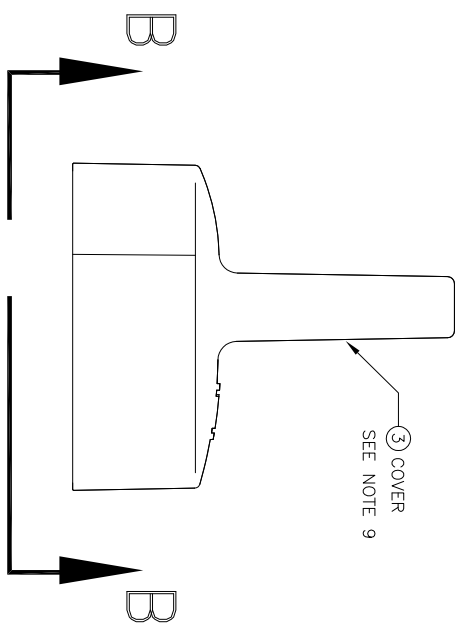

③ COVER
SEE NOTE 9

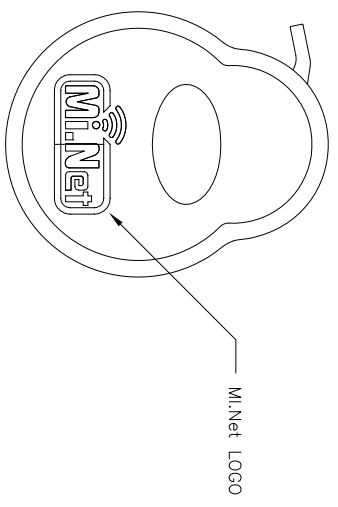

MiNet LOGO

MINode ASSEMBLY INSTRUCTIONS – CONT FOM SHT 2

- 8) UNIT TEST AND POTTING:
ONCE THE PWA IS INSTALLED AND HAS PASSED FINAL TEST, APPLY ENOUGH POTTING COMPOUND TO FILL THE BASE. SEE THE HERSEY POTTING PROCEDURE – TBD
- 9) TO APPLY THE O-RING, TURN THE COVER OVER AND INSERT THE ORING (ITEM5) INTO THE GROOVE MOLDED INTO THE COVER. THE ORING WILL CREATE A WATERTIGHT SEAL.

- 10) APPLY THE MINode LABEL (ITEM8) ON THE LEFT SIDE OF THE BASE IN THE SLOTTED LOCATION AS SHOWN. THIS LABEL WILL REFERENCE THE PRODUCT NAME, THE NODE ID AND 2 BAR CODES. THE FIRST 2 NUMBERS OF THE NODE ID INDICATE TO THE TESTER WHAT TO PROGRAM INTO THE UNIT. –20XXXXXX / INDICATES MINode HIGH VERSION
- 11) THE BOTTOM OF THE ENCLOSURE BASE HAS THE FCC IDENTIFICATION (SM6-MINODE-WATER) AND THE FCC 15.19 STATEMENT ETCHED INTO IT AS SHOWN IN DETAIL C.
- 12) ONCE THE POTTING & TEST ARE COMPLETE AND THE ORING IS INSTALLED, INSERT THE COVER ONTO THE BASE AND SNAP IN PLACE UNTIL LOCKED. THE UNIT IS FULLY ASSEMBLED & READY FOR SHIPMENT.

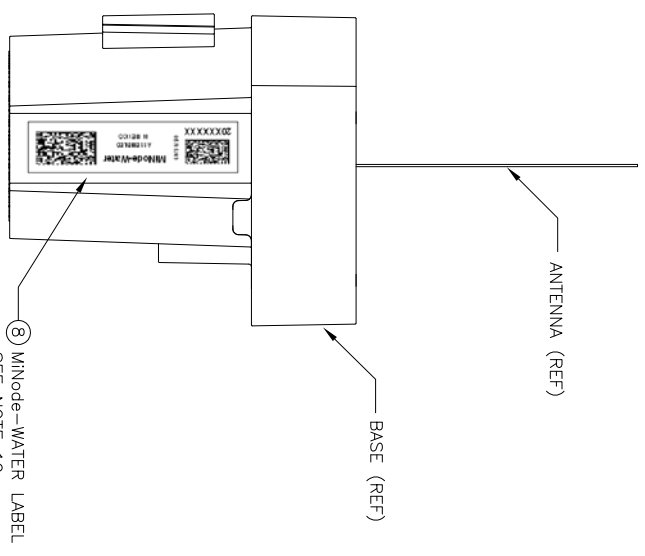

⑧ MINode-WATER LABEL
SEE NOTE 10

BASE-LEFT SIDE VIEW

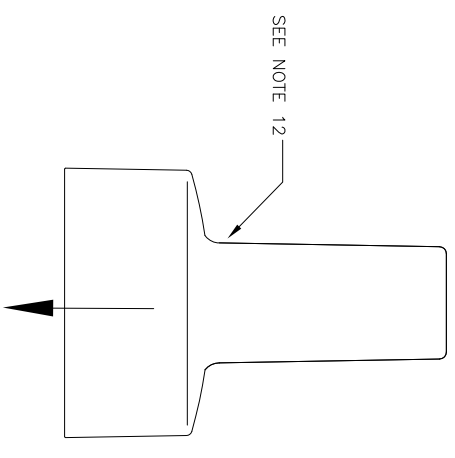

MINode-FRONT VIEW

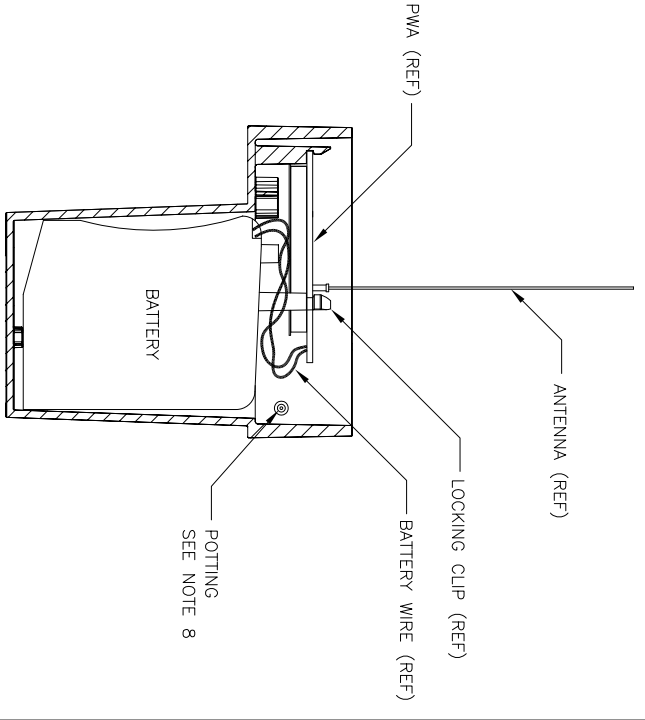

POTTING
SEE NOTE 8

SECTION A-A
(ROTATED FOR CLARITY)

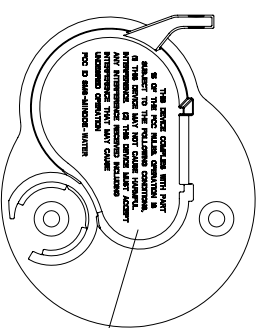

MINode-BOTTOM VIEW

THIS DEVICE COMPLIES WITH PART 15 OF THE FCC RULES. OPERATION IS SUBJECT TO THE FOLLOWING CONDITIONS,
(1) THIS DEVICE MAY NOT CAUSE HARMFUL INTERFERENCE. (2) THIS DEVICE MUST ACCEPT ANY INTERFERENCE RECEIVED INCLUDING UNDESIRED OPERATION

FCC ID SM6-MINODE-WATER

DETAIL C
(FCC ID ON BASE)

FCC IDENTIFICATION
SEE NOTE 11

MUELLER SYSTEMS CONFIDENTIAL

THIS DRAWING CONTAINS INFORMATION OF A CONFIDENTIAL AND/OR PROPRIETARY NATURE. IT IS TO BE KEPT CONFIDENTIAL AND NOT DISCLOSED TO OR FOR THE BENEFIT OF ANY OTHER PERSON OR ENTITY WITHOUT THE EXPRESS WRITTEN CONSENT OF MUELLER.

DWG file: 895-0024-003-3_100

SIZE	PART NO.	REV.
D	895-0024-003	100
SCALE: NONE	DO NOT SCALE DRAWING	SHEET 3 OF 3