



Product image for illustration purposes only

The easyRadio eRA-LoRa (Long Range) RF transceiver module uses Chirped Spread Spectrum (CSS) modulation together with DSP (Digital Signal Processing) to achieve greater range than traditional devices using OOK, FSK or GFSK modulation.

In addition, sensitivity and blocking performance are improved giving high interference immunity whilst still offering low power consumption.

The module is a complete sub-system that combines a high performance low power RF transceiver, a microcontroller and a voltage regulator.

Key operating parameters can be changed and configured by sending simple 'text' (ASCII character) commands to the module.

Features

- Chirped Spread Spectrum technology
- Pin compatible with easyRadio Advanced (eRA) series RF modules
- uFL RF connector for remote antennas
- Point to Point communication
- Half duplex transparent Serial Data Input and Output
- Up to 180 bytes per packet
- Familiar easyRadio commands
- Built in temperature sensor
- 'Flash' firmware upgrades. New features and updates can be quickly programmed using LPRS tools

Key Parameters

- Frequency: 903-927MHz
- Receiver sensitivity: down to -137dBm
- Multi-channel operation
- RF Power output: up to +17dBm (100mW)
- Receive current consumption: 15mA
- RSSI dynamic range: 127dB
- Line of Sight (LoS) range - 1km – 3km plus

User Programmable Options:

- Spreading factors 6: to 12
- Error correction rate
- Bandwidth: 125, 250, 500kHz
- Over air data rates of up to 300 kbps
- Host Data Rate: 2.4kbps – 115.2kbps

The variable spreading factor and error correction rate allow the user to optimise the bandwidth to provide a balance between sensitivity (range) and data rate.

Applications

- Required range is above 1km or transceiver is in poor RF location
- Suburban security alarms - void buildings, caravan or car storage sites, warehouses
- Rural security, farm buildings/equipment, livestock monitoring, remote irrigation pumps
- Data collection and monitoring over a wide area

FCC Warning Statement:

- This device complies with Part 15 of the FCC Rules. Operation is subject to the following two conditions:
 - (1) This device may not cause harmful interference, and
 - (2) This device must accept any interference received, including interference that may cause undesired operation.
- This equipment complies with FCC radiation exposure limits set forth for an uncontrolled environment. End users must follow the specific operating instructions for satisfying RF exposure compliance. This transmitter must not be co-located or operated in conjunction with any other antenna or transmitter.
- Changes or modifications not expressly approved by the party responsible for compliance could void the user's authority to operate the equipment.

Canada Warning Statement:

English:

Under Industry Canada regulations, this radio transmitter may only operate using an antenna of a type and maximum (or lesser) gain approved for the transmitter by Industry Canada.

To reduce potential radio interference to other users, the antenna type and its gain should be so chosen that the equivalent isotropically radiated power (e.i.r.p.) is not more than that necessary for successful communication.

This device complies with Industry Canada licence-exempt RSS standard(s). Operation is subject to the following two conditions: (1) this device may not cause interference, and (2) this device must accept any interference, including interference that may cause undesired operation of the device.

French:

Conformément à la réglementation d'Industrie Canada, le présent émetteur radio peut fonctionner avec une antenne d'un type et d'un gain maximal (ou inférieur) approuvé pour l'émetteur par Industrie Canada.

Dans le but de réduire les risques de brouillage radioélectrique à l'intention des autres utilisateurs, il faut choisir le type d'antenne et son gain de sorte que la puissance isotrope rayonnée équivalente (p.i.r.e.) ne dépasse pas l'intensité nécessaire à l'établissement d'une communication satisfaisante.

Le présent appareil est conforme aux CNR d'Industrie Canada applicables aux appareils radio exempts de licence. L'exploitation est autorisée aux deux conditions suivantes : (1) l'appareil ne doit pas produire de brouillage, et (2) l'utilisateur de l'appareil doit accepter tout brouillage radioélectrique subi, même si le brouillage est susceptible d'en compromettre le fonctionnement.

eRA-LoRa Transceiver

The easyRadio eRA-LoRa RF transceiver module is a complete sub-system that combines a high performance low power RF transceiver, a microcontroller and a voltage regulator.

The Serial Data Input (SDI) and Serial Data Output (SDO) by default operate at the standard 19,200 Baud and two handshake lines provide optional flow control to and from the host. The easyRadio Transceiver can accept and transmit up to 180 bytes of data, which it buffers internally before transmitting in an efficient over-air code format.

Any other eRA-LoRa transceiver, within range and on the same settings, that 'hears' the transmission will decode the message and place the recovered data within a receive buffer that can then be downloaded to the receiving host for processing and interpretation. Radio transmission and reception is bi-directional (half duplex) i.e. transmit OR receive but not simultaneously. Extra internal buffers however, allow the user to upload data while a download is in progress giving the appearance of fully duplex data flow.

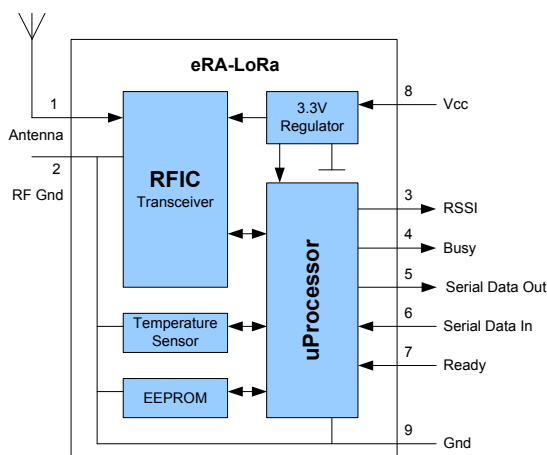

Block Diagram

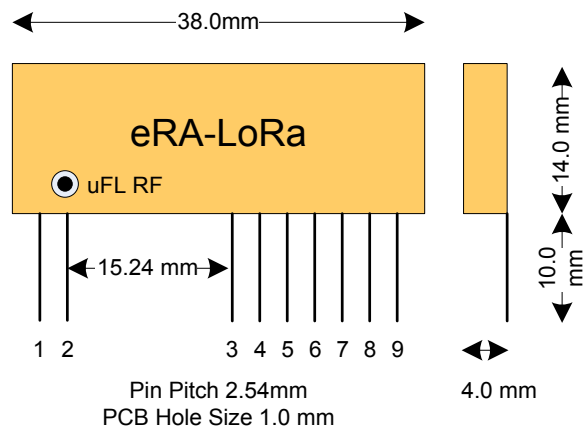

Physical Dimensions

Pin Description

Pin No	Name	Description	Notes
1	Antenna	50Ω , has been cut off. Only the UFL connector is used.	
2	RF Ground	RF ground. Connect to antenna ground (coaxial cable screen braid) and local ground plane. Internally connected to other Ground pins.	
3	Programmable IO	Provisional	
4	Busy Output	Digital output indicates that transceiver is ready to receive serial data from host.	CTS function
5	Serial Data Out	Digital output for received serial data to host	
6	Serial Data In	Digital input for serial data to be transmitted	
7	Ready Input	Digital Input to indicate that Host is Ready to receive serial data from transceiver	RTS function
8	Vcc	Positive supply pin. +2.5 to +5.5 Volts. This should be a 'clean' noise free supply with less than 25mV of ripple.	
9	Ground	Connect to supply 0 Volt and ground plane	

Checklist

The module operates internally from an on board 3.3 Volt low drop regulator. The logic levels of the input/output pins are therefore between 0 Volt and 3.3 Volts. Outputs will drive logic operating at 3.3 Volts and inputs will be correctly driven by logic operating at 5 Volts. Fit 1K resistors in series with data lines when interfacing to 5V logic.

The serial inputs and outputs are intended for connection to a UART or similar low voltage logic device. Do not connect any of the inputs or outputs directly to an RS232 port. The transceiver module may be permanently damaged by the voltages (+/- 12V) present on RS232 signal lines.

When handshaking is enabled the 'Host Ready Input' should be held at 0 Volt (Ground) in the idle state.

Absolute Maximum Ratings

Operating Temperature Range	-40° C to +85° C
Storage Temperature Range	-40° C to +85° C
Vcc	- 0.3 to + 5.5 Volts
All Other Pins (N.B.)	- 0.3 to +3.3 Volts
Antenna	50V p-p @ < 10MHz Should be isolated to prevent damage from ESD

Performance Data: eRA-LoRa. Supply +5.0 Volt ± 5%, Temperature 20° C

DC Parameters	Pin	Min	Typical	Max	Units	Notes
Supply Voltage (Vcc)	8	2.5	3.3-5.0	5.5	Volts	
Transmit supply current	8	18	90	125	mA	90mA at +17dBm 125mA at +20dBm
Receive supply current	8		10	11.2	mA	2
Sleep Mode current	8		1		µA	4
Interface Levels						
Data Output Logic 1			3.1		Volts	10k load to +Vcc supply
Data Output Logic 0			0.1		Volts	10k load to +Vcc supply
Logic Output Current				25	mA	
Data Input Logic 1		2.0		3.6	Volts	
Data Input Logic 0				0.2	Volts	
Input Pull-ups			100		KΩ	1
RF Parameters						
Antenna Impedance	1		50		Ohms	
RF Frequency					MHz	See ER Configuration Command set
		903	915	927	MHz	
Transmitter						
RF Power Output	1		+7	+7	dBm	868MHz - 50Ω load
	1		+17	+20	dBm	915MHz - 50Ω load
Frequency accuracy			±10		ppm	Overall
Harmonics/Spurious Emissions			-47	< -36	dBm	Meets EN 300 220-3
Over Air Data rate				500	Kbps	
Receiver						
		SF6		SF12		
		-122		-137	dBm	At 125kHz bandwidth (SF 6 - 12)
		-119		-134	dBm	At 250kHz bandwidth
		-116		-131	dBm	At 500kHz bandwidth
Serial Data Rate		2.4	19.2	115.2	Kbps	Host interface
Logic Timing						
Initial Power Up Time			1		mS	2,3
Mechanical						
Size			38 x 14 x 4		mm	
Pin Pitch			2.54		mm	(Standard 0.1 Inches)
Weight			3.5		grams	

Notes:

1. The 'Host Ready Input' and the 'Serial Data Input' have 'weak' internal pull-ups enabled.
2. The transceiver will then be ready to receive (default) or transmit. It would normally be left in this powered state ready to receive data.
3. During power up the Busy Output line goes high and then goes low when ready for use.

easyRadio eRA Configuration Command Set

Key operating parameters of eRA can be changed and configured by sending the 'text' (ASCII character) commands detailed below. These commands can be executed using 'easyRadio Companion' software, any 'Terminal' software operating on a PC or from the host microcontroller.

The commands should be sent exactly as shown: i.e. case sensitive with no spaces between characters. Commands are not executed until the Acknowledgement sequence (ACK) is sent to and processed by the module.

To send the commands follow this procedure:

Send Command from host: e.g. ER_CMD#U5 (Set UART BAUD to 38400)
 Wait for the completion of the echo of the Command from the module. e.g. ER_CMD#U5
 Send the ACK command as the three upper case ASCII characters 'A' 'C' 'K' in sequence with no spaces

Commands ending with '?' (see below) do not require any ACK.

Host Serial Communication Settings					
Command	UART Data Rate	✓	Tick Indicates Factory Default setting		
ER_CMD#U1	2400				
ER_CMD#U2	4800				
ER_CMD#U3	9600				
ER_CMD#U4	19200	✓			
ER_CMD#U5	38400				
ER_CMD#U6	31250		MIDI - Musical Instrument Digital Interface (Not supported by PC UARTS)		
ER_CMD#U7	76800		(Not supported by PC UARTS)		
ER_CMD#U8	115200				
ER_CMD#U?	Get UART Value		The module replies with the current UART data rate value E.g: ER_CMD#U2 - No 'ACK' is required		
ER_CMD#A70	No Parity	✓	Data = 1 Start, 8 Data, No Parity, 1 Stop		
ER_CMD#A71	Even Parity		Data = 1 Start, 8 Data, 1 Parity, 1 Stop		
ER_CMD#A72	Odd Parity		Data = 1 Start, 8 Data, 1 Parity, 1 Stop		
ER_CMD#A40	Disable Fast ACK	✓			
ER_CMD#A41	Enable Fast ACK		See notes below		
Transmit RF Power Output Settings					
			eRA-LoRa		Units
			868	902-928	
ER_CMD#P0			-2	-1	dBm
ER_CMD#P1			-1	1	dBm
ER_CMD#P2			0	3	dBm
ER_CMD#P3			1	5	dBm
ER_CMD#P4			2	7	dBm
ER_CMD#P5			3	9	dBm
ER_CMD#P6			4	11	dBm
ER_CMD#P7			5	13	dBm
ER_CMD#P8			6	15	dBm
ER_CMD#P9		✓	7	17	dBm
ER_CMD#P?	Get Power Value		The module replies with the current power value. e.g: ER_CMD#P9 - No ACK is required.		
RF Channel Settings					
ER_CMD#Cx	Where x = Channel Number in decimal		E.g. For Channel 5: ER_CMD#C5 or ER_CMD#C05 (leading zero) or ER_CMD#C005		

			Uppercase 'C' stores value in EEPROM			
ER_CMD#cx	As uppercase C		Lowercase 'c' does not store value in EEPROM			
ER_CMD#C?	Get Channel Value		The module replies with the current channel setting E.g: ER_CMD#C9 - No ACK is required.			
Signal Bandwidth						
			Bandwidth		Data Rate	
ER_CMD#B0	Set Signal bandwidth		125	kHz	?	bps
ER_CMD#B1			250	kHz	?	bps
ER_CMD#B2		✓	500	kHz	?	bps
Band Plan						
ER_CMD#b0	0	✓	869.850		MHz	
ER_CMD#b1	1		903.000		MHz	
Frequency Settings						
ER_CMD#F	Set Absolute Frequency		Sets the absolute frequency to xxxxxxxx in Hex E.g. ER_CMD#F1B4C8680 sets the radio frequency to 458000000Hz. This will override until another 'b' command is sent			
ER_CMD#F?	Get current Frequency value		Returns the current frequency value as 8 bytes of Hex E.g. ER_CMD#F? Returns 1B4C8680 which is 458MHz			
Spreading Factor						
	Chips					
ER_CMD#s0	64					
ER_CMD#s1	128					
ER_CMD#s2	256					
ER_CMD#s3	512					
ER_CMD#s4	1024	✓				
ER_CMD#s5	2048					
ER_CMD#s6	4096					
Miscellaneous						
ER_CMD#R0	Reset Module (POR)		Reset module and retrieve all Power On Reset values			
ER_CMD#R1	Reset to Defaults		Restores factory default settings			
ER_CMD#A10	Encryption Off	✓	LPRS Proprietary Encryption for P2P			
ER_CMD#A11	Encryption On					
ER_CMD#A50	Handshaking Off	✓				
ER_CMD#H2	Handshaking Off		Use for back compatibility only			
ER_CMD#A51	Handshaking On					
ER_CMD#H1	Handshaking On		Use for back compatibility only			
ER_CMD#a00	RSSI Off	✓	Received Signal Strength Indicator			
ER_CMD#a01	RSSI On		Each received packet delivered is preceded by the 8 bit RSSI value of the received packet			
Test Modes						
ER_CMD#T0	Upper FSK Carrier		No modulation			
ER_CMD#T1	Modulated Carrier		1 kHz ??? modulation - with temperature compensation			
ER_CMD#T2	Lower FSK Carrier		No modulation			
ER_CMD#T3	Get Firmware Revision		Returns module firmware revision string E.g. eRA400TRS V3.6.23			
ER_CMD#T4	RAW Data Out		Output on the CTS pin			
ER_CMD#T5	Modulated Carrier		Without temperature compensation			
ER_CMD#T6	Reserved					
ER_CMD#T7	Read on chip temperature Sensor		Example reply: -15.0°C or 23.7°C			
ER_CMD#T8	Last Packet RSSI		Returns the Hex value of the RSSI (Received Signal Strength Indicator) register measured on the last valid packet			

ER_CMD#T9	RSSI Value		Return current live RSSI in HEX
Other/Special Commands			
ER_CMD#L40202	Enable RAW Data FM mode		Use FM/FSK modulation/demodulation at current frequency settings
ER_CMD#L40205	Enable RAW Data AM mode		Use AM/ASK modulation/demodulation at current frequency settings
ER_CMD#L40200	Disable RAW Data mode		Restore easyRadio mode. Pin 3 low during PoR
ER_CMD#a21	Enable LBT		Listen Before Talk
ER_CMD#a20	Disable LBT	✓	Listen Before Talk
ER_CMD#L7	Group ID		
ER_CMD#L8	Encryption		

Channel Frequencies vs Bandwidth Settings

Each channel frequency is calculated relative to the channel number, the channel band width, and the start frequency of the channel.

Three commands control the settings of each of these parameters:

Channel Command:	ER_CMD#Cn	Where n is channel number (See command table)
Bandwidth Command:	ER_CMD#Bn	Where n is the Channel spacing
Band Plan Command:	ER_CMD#bn	Where n is the START frequency of the band plan being used

The centre frequency of each channel is calculated using the formula:

$$\text{Centre Frequency (f)} = b + cs + \frac{s}{2}$$

Where b = Band plan start frequency
c = Channel number
s = Channel spacing

Application & Operation of eRA-LoRa Transceiver

The diagram below shows a typical system block diagram comprising hosts (user's application) connected to easyRadio transceivers. The hosts (A & B) will be monitoring (collecting data) and/or controlling (sending data) to some real world application.

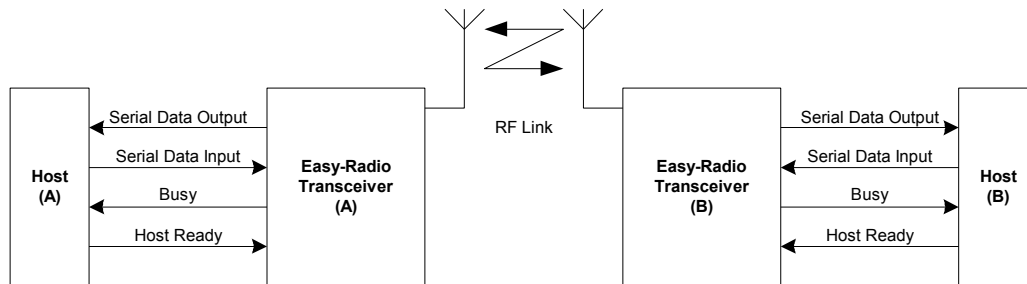

Typical System Block Diagram

The hosts provide serial data input and output lines and two 'handshaking' lines that control the flow of data to and from the easyRadio Transceivers. The 'Busy' output line, when active, indicates that the transceiver is undertaking an internal task and is not ready to receive serial data. The 'Host Ready' input is used to indicate that the host is ready to receive the data held in the buffer of the easyRadio Transceiver.

The host should check before sending data that the 'Busy' line is not high, as this would indicate that the transceiver is unable to reliably receive further data. It should also pull the 'Host Ready' line low and check that no data appears on the Serial Data Output line.

The Busy output is active all the time regardless of handshaking setting. The host Ready is enabled by the handshaking setting command.

Timing Specifications		Units	Notes
Host Serial Input/Output	2400, 4800, 9600, 19200, 38400, 31250 (MIDI), 76800 & 115200	baud	1
Host Character Format	1 Start, 8 Data, No Parity, 1 Stop	Bits	2
End of Data Delay	2 x BAUD Byte Duration	mS	3
RF Transmit duration	Depends on Bandwidth and data rate setting	mS	4
Buffer Size	180	Bytes	5

Notes

1. Data is inverted i.e. Start Bit is logic low. The inputs are intended for direct connection to a microcontroller UART or to RS232 inputs and outputs via an RS232 Level translator such as a Maxim MAX232, which invert the logic of the RS232 signals. This allows direct connection to, for example a microcontroller UART. The data rate is user programmable (Default 19200 baud) and may differ between individual units within a system.
2. 1 start, 8 data, 1 stop = 10 bits @ 104uS/bit = 0.52mS/character at 19200 Baud. (Default)
3. The 'End of Data' delay is fixed at twice the character time.
4. A fixed package overhead of xx is added to all packets.
5. The buffer size is limited to 180 bytes. Sending more than 180 bytes will cause loss of data.
6. CTS pin will go high 2 bytes before the buffer is full. This allows characters already sent to be accepted by the ER module.

Product Order Codes

Name	Description	Order Code
eRA-LoRa	CE/FCC/IC Certified Radio Module	ERA-LORA

Please contact the sales office for availability of other variants of the standard product. The software interface can be customised to specific requirements for high volume applications.

easyRadio Advanced Firmware Versions

Version	Date	Revision	Known Issues
3.6.2XXX	January 2016	Initial Release	

Changes to this Document

This data sheet has been updated to reflect firmware changes throughout the range of modules. Specific alterations are recorded in the documentation history above.

Document History

Issue	Date	Revision
1.0	February 2016	Provisional datasheet

Copyright

Insert standard text here

Disclaimer

Insert standard text here

Terms and Conditions of Use

Insert standard text here

Contact Information

For further information or technical assistance please contact:

FCC STATEMENT:

NOTE: This equipment has been tested and found to comply with the limits for a Class B digital device, pursuant to Part 15 of the FCC Rules. These limits are designed to provide reasonable protection against harmful interference in a residential installation.

This equipment generates uses and can radiate radio frequency energy and, if not installed and used in accordance with the instructions, may cause harmful interference to radio communications. However, there is no guarantee that interference will not occur in a particular installation. If this equipment does cause harmful interference to radio or television reception, which can be determined by turning the equipment off and on, the user is encouraged to try to correct the interference by one or more of the following measures:

Reorient or relocate the receiving antenna.

Increase the separation between the equipment and receiver.

Connect the equipment into an outlet on a circuit different from that to which the receiver is connected.

Consult the dealer or an experienced radio/TV technician for help.

OEM INTEGRATION INSTRUCTIONS:

This device is intended only for OEM integrators under the following conditions: The module must be installed in the host equipment such that 20 cm is maintained between the antenna and users, and the transmitter module may not be co-located with any other transmitter or antenna. The module shall be only used with the internal antenna(s) that has been originally tested and certified with this module. As long as 3 conditions above are met, further transmitter test will not be required. However, the OEM integrator is still responsible for testing their end-product for any additional compliance requirements required with this module installed (for example, digital device emissions, PC peripheral requirements, etc.).

Validity of using the module certification:

In the event that these conditions cannot be met (for example certain laptop configurations or co-location with another transmitter), then the FCC/IC authorization for this module in combination with the host equipment is no longer considered valid and the FCC ID/ IC of the module cannot be used on the final product. In these circumstances, the OEM integrator will be responsible for re-evaluating the end product (including the transmitter) and obtaining a separate FCC/IC authorization.

End product labeling:

This transmitter module is authorized only for use in device where the antenna may be installed such that 20 cm may be maintained between the antenna and users. The final end product must be labeled in a visible area with the following: "Contains FCC ID: SLW-ERALORA".

Or "Contains IC: 11377A-ERALORA".

Information that must be placed in the end user manual:

The OEM integrator has to be aware not to provide information to the end user regarding how to

install or remove this RF module in the user's manual of the end product which integrates this module. The end user manual shall include all required regulatory information/warning as show in this manual.

This device must be kept away from all persons by 20cm or more and installations using less distance, or installations using antennas with gain greater than that with which this was Certified will require additional approvals.

Antenna Specification:

Type: External Antenna

Gain: 3dBi