

TEST REPORT

Report No.: 23070047HKG-003

Maison Battat Inc.

Application For Certification
(Original Grant)

FCC ID: SLU23D24R19

Transceiver – 2.4GHz RC Car

Prepared and Checked by:

Approved by:

Signed on File

Leung Chun Ning, Peter

Assistant Engineer

Wong Kwok Yeung, Kenneth

Assistant Manager

Date: August 01, 2023

Intertek's standard Terms and Conditions can be obtained at our website <http://www.intertek.com/terms/>.

The test report only allows to be revised within the retention period unless further standard or the requirement was noticed.

This report is for the exclusive use of Intertek's Client and is provided pursuant to the agreement between Intertek and its Client. Intertek's responsibility and liability are limited to the terms and conditions of the agreement. Intertek assumes no liability to any party, other than to the Client in accordance with the agreement, for any loss, expense or damage occasioned by the use of this report. Only the Client is authorized to permit copying or distribution of this report and then only in its entirety. Any use of the Intertek name or one of its marks for the sale or advertisement of the tested material, product or service must first be approved in writing by Intertek. The observations and test results in this report are relevant only to the sample tested. This report by itself does not imply that the material, product, or service is or has ever been under an Intertek certification program.

© 2017 Intertek

TEST REPORT

GENERAL INFORMATION

| | |
|----------------------------------|---|
| Grantee: | Maison Battat Inc. |
| Grantee Address: | 8440 Darnley Road, Montreal, QC Quebec, Canada H4T 1M4. |
| FCC ID: | SLU23D24R19 |
| FCC Model(s): | WH1270 |
| Additional Model(s): | WH1270Z, WH1272, WH1272Z |
| Type of EUT: | Transceiver |
| Description of EUT: | R/C Sports Car – Vega (WH1270, WH1270Z), R/C Sports Car – Flux (WH1272, WH1272Z) |
| Brand Name: | R/C Sports Car – Vega, R/C Sports Car – Flux |
| Serial Number: | N/A |
| Sample Receipt Date: | July 04, 2023 |
| Date of Test: | July 05, 2023 to July 27, 2023 |
| Report Date: | August 01, 2023 |
| Environmental Conditions: | Temperature: +10 to 40°C Relative Humidity: 10 to 90% |
| Conclusion: | Test was conducted by client submitted sample. The submitted sample as received complied with the 47 CFR Part 15 Certification. |

TEST REPORT

SUMMARY OF TEST RESULT

| Test Items | FCC Part 15 Section | Results |
|--|---------------------|----------------|
| Transmitter Power Line Conducted Emissions | 15.207 | Not Applicable |
| Radiated Emission | 15.249, 15.209 | Complied |
| Radiated Emission on the Bandedge | | Complied |
| Radiated Emission in Restricted Bands | 15.205 | Complied |

The equipment under test is found to be complying with the following standards:

FCC Part 15, October 1, 2021 Edition

- Note:
1. The EUT uses a permanently attached antenna which, in accordance to section 15.203, is considered sufficient to comply with the pervisions of this section.
 2. Pursuant to FCC Part 15 Section 15.215(c), the 20dB bandwidth of the emission was contained within the frequency band designated (mentioned as above) which the EUT operated. The effects, if any, from frequency sweeping, frequency hopping, other modulation techniques and frequency stability over expected variations in temperature and supply voltage were considered.

TEST REPORT

TABLE OF CONTENTS

1.0 GENERAL DESCRIPTION 5

1.1 Product Description.....5

1.2 Related Submittal(s) Grants5

1.3 Test Methodology5

1.4 Test Facility.....5

2.0 SYSTEM TEST CONFIGURATION 6

2.1 Justification6

2.2 EUT Exercising Software.....6

2.3 Special Accessories.....6

2.4 Measurement Uncertainty.....6

2.5 Support Equipment List and Description.....6

3.0 EMISSION RESULTS 7

3.1 Field Strength Calculation7

3.2 Radiated Emission Configuration Photograph.....8

3.3 Radiated Emission Data.....8

4.0 EQUIPMENT PHOTOGRAPHS..... 13

5.0 PRODUCT LABELLING 13

6.0 TECHNICAL SPECIFICATIONS 13

7.0 INSTRUCTION MANUAL 13

8.0 MISCELLANEOUS INFORMATION 14

8.1 Radiated Emission on the Bandedge14

8.2 Emissions Test Procedures15

8.3 Occupied Bandwidth17

9.0 EQUIPMENT LIST 18

TEST REPORT

1.0 GENERAL DESCRIPTION

1.1 Product Description

The Equipment Under Test (EUT), is a portable 2.4GHz Transceiver (Car Unit) for a RC Car. The sample supplied operated on 46 channels, normally at 2420 - 2465MHz. The channels are separated with 1MHz spacing.

The EUT is powered by 4 x 1.5V AA batteries. The car has 2 modes, the "TRY ME" and the on mode. For the "TRY ME" mode, after switching on the EUT, sound will be emitted from the car based on the button pressed on the car. For the on mode, it has all the functions that the "TRY ME" mode has. In addition, the car will be moved forward or backward and turned left and right based on the switches pressed in the controller. Sound will be emitted from the car based on the button pressed in the controller.

The Models: WH1270Z, WH1272 and WH1272Z are the same as the Model: WH1270 in hardware aspect as declared by client. The models are different in model number, item name, color, packaging and non-conductive accessories only as declared by client.

Antenna Type: Internal, Integral

For electronic filing, the brief circuit description is saved with filename: Descri.pdf.

1.2 Related Submittal(s) Grants

This is a single application for certification of a transceiver.

The Certificate procedure of transceiver for this transceiver (with FCC ID: SLU23D24T19) is being processed as the same time of this application.

1.3 Test Methodology

Radiated emission measurements were performed according to the procedures in ANSI C63.10 (2013). All radiated measurements were performed in an 3m Chamber. Preliminary scans were performed in the 3m Chamber only to determine worst case modes. All radiated tests were performed at an antenna to EUT distance of 3 meters, unless stated otherwise in the "**Justification Section**" of this Application.

1.4 Test Facility

The 3m Chamber used to collect the radiated data is located at Workshop No. 3, G/F., World-Wide Industrial Centre, 43-47 Shan Mei Street, Fo Tan, Sha Tin, N.T., Hong Kong SAR, China. This test facility and site measurement data have been placed on file with the FCC.

TEST REPORT

2.0 SYSTEM TEST CONFIGURATION

2.1 Justification

The system was configured for testing in a typical fashion (as a customer would normally use it), and in the confines as outlined in ANSI C63.10 (2013).

The device was powered by 6.0VDC (4 x 1.5V AA Batteries).

For maximizing emissions, the EUT was rotated through 360°, the antenna height was varied from 1 meter to 4 meters above the ground plane, and the antenna polarization was changed. This step by step procedure for maximizing emissions led to the data reported in Exhibit 3.0.

The unit was operated standalone and placed in the center of the turntable.

The equipment under test (EUT) was configured for testing in a typical fashion (as a customer would normally use it). The EUT was mounted to a plastic stand if necessary and placed on the wooden turntable, which enabled the engineer to maximize emissions through its placement in the three orthogonal axes.

2.2 EUT Exercising Software

The EUT exercise program (if any) used during radiated testing was designed to exercise the various system components in a manner similar to a typical use.

2.3 Special Accessories

There are no special accessories necessary for compliance of this product.

2.4 Measurement Uncertainty

Decision Rule for compliance: For FCC/IC standard, the measured value must be within the limits of applicable standard without accounting for the measurement uncertainty. For EN/IEC/HKTA/HKTC standard, conformity rules will be used as per standard directly excepted EN/IEC 61000-3-2, EN/IEC 61000-3-3, HKTA1004, HKCA1008, HKTA1019, HKTA1020, HKTA1041 and HKTA1044. For these excepted or not mentioned standards, Cl 4.2.2 of ILAC-G8:09/2019 decision rules will be reference and guard band will be equal to our measurement uncertainty with 95% confidence level (k=2). In case, the measured value is within guard band region, undetermined decision will be used.

2.5 Support Equipment List and Description

Not Applicable

TEST REPORT

3.0 EMISSION RESULTS

Data is included of the worst case configuration (the configuration which resulted in the highest emission levels). A sample calculation, configuration photographs and data tables of the emissions are included.

3.1 Field Strength Calculation

The field strength is calculated by adding the Antenna Factor and Cable Factor, and subtracting the Amplifier Gain (if any), Average Factor (optional) from the measured reading.

The basic equation with a sample calculation is as follows:

$$FS = RA + AF + CF - AG - AV$$

where FS = Field Strength in dB μ V/m
 RA = Receiver Amplitude (including preamplifier) in dB μ V
 AF = Antenna Factor in dB
 CF = Cable Attenuation Factor in dB
 AG = Amplifier Gain in dB
 AV = Average Factor in dB

In the following table(s), the reading shown on the data table reflects the preamplifier gain.

An example for the calculations in the following table is as follows:

$$FS = RR + LF$$

where FS = Field Strength in dB μ V/m
 RR = RA - AG - AV in dB μ V
 LF = CF + AF in dB

Assume a receiver reading of 52.0 dB μ V is obtained. The antenna factor of 7.4 dB and cable factor of 1.6 dB are added. The amplifier gain of 29.0 dB and average factor of 5.0 dB are subtracted, giving a field strength of 27.0 dB μ V/m. This value in dB μ V/m was converted to its corresponding level in μ V/m.

| | | | |
|----|---|--------------------------------|----------------------|
| RA | = | 52.0 dB μ V/m | |
| AF | = | 7.4 dB | RR = 18.0 dB μ V |
| CF | = | 1.6 dB | LF = 9.0 dB |
| AG | = | 29.0 dB | |
| AV | = | 5.0 dB | |
| FS | = | RR + LF | |
| FS | = | 18.0 + 9.0 = 27.0 dB μ V/m | |

Level in μ V/m = Common Antilogarithm [(27.0 dB μ V/m)/20] = 22.4 μ V/m

TEST REPORT

3.2 Radiated Emission Configuration Photograph

The worst case in radiated emission was found at 955.25875 MHz

For electronic filing, the worst case radiated emission configuration photographs are saved with filename: Radiated Photos.pdf.

3.3 Radiated Emission Data

The data on the following page lists the significant emission frequencies, the limit and the margin of compliance. Numbers with a minus sign are below the limit.

Judgment: Passed by 11.3 dB

TEST REPORT

RADIATED EMISSIONS

Model: WH1270
Date of Test: July 05, 2023
Worst-Case Operating Mode: Transmitting

Table 1

Pursuant to FCC Part 15 Section 15.249 Requirement

Lowest Channel

| Polarization | Frequency (MHz) | Reading (dBµV) | Pre-Amp Gain (dB) | Antenna Factor (dB) | Net at 3m - Average (dBµV/m) | Average Limit at 3m (dBµV/m) | Margin (dB) |
|--------------|-----------------|----------------|-------------------|---------------------|------------------------------|------------------------------|-------------|
| V | 2420.000 | 76.8 | 33 | 29.4 | 73.2 | 94.0 | -20.8 |
| V | 2400.000 | 43.7 | 33 | 29.4 | 40.1 | 54.0 | -13.9 |
| V | 4840.000 | 27.1 | 33 | 34.9 | 29.0 | 54.0 | -25.0 |
| H | 7260.000 | 28.9 | 33 | 37.9 | 33.8 | 54.0 | -20.2 |
| H | 9680.000 | 28.3 | 33 | 40.4 | 35.7 | 54.0 | -18.3 |
| H | 12100.000 | 30.8 | 33 | 40.5 | 38.3 | 54.0 | -15.7 |
| H | 14520.000 | 34.7 | 33 | 38.4 | 40.1 | 54.0 | -13.9 |

| Polarization | Frequency (MHz) | Reading (dBµV) | Pre-Amp Gain (dB) | Antenna Factor (dB) | Net at 3m - Peak (dBµV/m) | Peak Limit at 3m (dBµV/m) | Margin (dB) |
|--------------|-----------------|----------------|-------------------|---------------------|---------------------------|---------------------------|-------------|
| V | 2420.000 | 98.8 | 33 | 29.4 | 95.2 | 114.0 | -18.8 |
| V | 2400.000 | 60.9 | 33 | 29.4 | 57.3 | 74.0 | -16.7 |
| V | 4840.000 | 44.3 | 33 | 34.9 | 46.2 | 74.0 | -27.8 |
| H | 7260.000 | 43.4 | 33 | 37.9 | 48.3 | 74.0 | -25.7 |
| H | 9680.000 | 42.0 | 33 | 40.4 | 49.4 | 74.0 | -24.6 |
| H | 12100.000 | 44.7 | 33 | 40.5 | 52.2 | 74.0 | -21.8 |
| H | 14520.000 | 48.7 | 33 | 38.4 | 54.1 | 74.0 | -19.9 |

- Notes: 1. Peak Detector Data unless otherwise stated.
 2. Average detector is applied according to ANSI C63.10.
 3. All measurements were made at 3 meters.
 4. Negative value in the margin column shows emission below limit.
 5. Horn antenna is used for the emission over 1000MHz.
 6. Emissions within the restricted band meet the requirement of FCC Part 15 Section 15.205.
 7. Measurement Uncertainty is ±5.3dB at a level of confidence of 95%.

TEST REPORT

RADIATED EMISSIONS

Model: WH1270
Date of Test: July 05, 2023
Worst-Case Operating Mode: Transmitting

Table 2

Pursuant to FCC Part 15 Section 15.249 Requirement

Middle Channel

| Polarization | Frequency (MHz) | Reading (dBµV) | Pre-Amp Gain (dB) | Antenna Factor (dB) | Net at 3m - Average (dBµV/m) | Average Limit at 3m (dBµV/m) | Margin (dB) |
|--------------|-----------------|----------------|-------------------|---------------------|------------------------------|------------------------------|-------------|
| V | 2442.000 | 76.3 | 33 | 29.4 | 72.7 | 94.0 | -21.3 |
| V | 4884.000 | 31.0 | 33 | 34.9 | 32.9 | 54.0 | -21.1 |
| V | 7326.000 | 28.6 | 33 | 37.9 | 33.5 | 54.0 | -20.5 |
| V | 9768.000 | 28.6 | 33 | 40.4 | 36.0 | 54.0 | -18.0 |
| V | 12210.000 | 30.1 | 33 | 40.5 | 37.6 | 54.0 | -16.4 |
| V | 14652.000 | 34.9 | 33 | 38.4 | 40.3 | 54.0 | -13.7 |

| Polarization | Frequency (MHz) | Reading (dBµV) | Pre-Amp Gain (dB) | Antenna Factor (dB) | Net at 3m - Peak (dBµV/m) | Peak Limit at 3m (dBµV/m) | Margin (dB) |
|--------------|-----------------|----------------|-------------------|---------------------|---------------------------|---------------------------|-------------|
| V | 2442.000 | 97.2 | 33 | 29.4 | 93.6 | 114.0 | -20.4 |
| V | 4884.000 | 44.2 | 33 | 34.9 | 46.1 | 74.0 | -27.9 |
| V | 7326.000 | 42.6 | 33 | 37.9 | 47.5 | 74.0 | -26.5 |
| V | 9768.000 | 41.9 | 33 | 40.4 | 49.3 | 74.0 | -24.7 |
| V | 12210.000 | 43.8 | 33 | 40.5 | 51.3 | 74.0 | -22.7 |
| V | 14652.000 | 49.9 | 33 | 38.4 | 55.3 | 74.0 | -18.7 |

- Notes:
1. Peak Detector Data unless otherwise stated.
 2. Average detector is applied according to ANSI C63.10.
 3. All measurements were made at 3 meters.
 4. Negative value in the margin column shows emission below limit.
 5. Horn antenna is used for the emission over 1000MHz.
 6. Emissions within the restricted band meet the requirement of FCC Part 15 Section 15.205.
 7. Measurement Uncertainty is ±5.3dB at a level of confidence of 95%.

TEST REPORT

RADIATED EMISSIONS

Model: WH1270
Date of Test: July 05, 2023
Worst-Case Operating Mode: Transmitting

Table 3

Pursuant to FCC Part 15 Section 15.249 Requirement

Highest Channel

| Polarization | Frequency (MHz) | Reading (dBµV) | Pre-Amp Gain (dB) | Antenna Factor (dB) | Net at 3m - Average (dBµV/m) | Average Limit at 3m (dBµV/m) | Margin (dB) |
|--------------|-----------------|----------------|-------------------|---------------------|------------------------------|------------------------------|-------------|
| V | 2465.000 | 77.4 | 33 | 29.4 | 73.8 | 94.0 | -20.2 |
| V | 2483.500 | 44.4 | 33 | 29.4 | 40.8 | 54.0 | -13.2 |
| V | 4930.000 | 28.0 | 33 | 34.9 | 29.9 | 54.0 | -24.1 |
| H | 7395.000 | 28.2 | 33 | 37.9 | 33.1 | 54.0 | -20.9 |
| H | 9860.000 | 29.0 | 33 | 40.4 | 36.4 | 54.0 | -17.6 |
| H | 12325.000 | 30.7 | 33 | 40.5 | 38.2 | 54.0 | -15.8 |
| H | 14790.000 | 35.2 | 33 | 38.4 | 40.6 | 54.0 | -13.4 |

| Polarization | Frequency (MHz) | Reading (dBµV) | Pre-Amp Gain (dB) | Antenna Factor (dB) | Net at 3m - Peak (dBµV/m) | Peak Limit at 3m (dBµV/m) | Margin (dB) |
|--------------|-----------------|----------------|-------------------|---------------------|---------------------------|---------------------------|-------------|
| V | 2465.000 | 98.8 | 33 | 29.4 | 95.2 | 114.0 | -18.8 |
| V | 2483.500 | 62.9 | 33 | 29.4 | 59.3 | 74.0 | -14.7 |
| V | 4930.000 | 45.5 | 33 | 34.9 | 47.4 | 74.0 | -26.6 |
| H | 7395.000 | 42.3 | 33 | 37.9 | 47.2 | 74.0 | -26.8 |
| H | 9860.000 | 42.8 | 33 | 40.4 | 50.2 | 74.0 | -23.8 |
| H | 12325.000 | 44.2 | 33 | 40.5 | 51.7 | 74.0 | -22.3 |
| H | 14790.000 | 49.1 | 33 | 38.4 | 54.5 | 74.0 | -19.5 |

- Notes:
1. Peak Detector Data unless otherwise stated.
 2. Average detector is applied according to ANSI C63.10.
 3. All measurements were made at 3 meters.
 4. Negative value in the margin column shows emission below limit.
 5. Horn antenna is used for the emission over 1000MHz.
 6. Emissions within the restricted band meet the requirement of FCC Part 15 Section 15.205.
 7. Measurement Uncertainty is ±5.3dB at a level of confidence of 95%.

TEST REPORT

RADIATED EMISSIONS

Model: WH1270
Date of Test: July 05, 2023
Worst-Case Operating Mode: Transmitting

Table 4

Pursuant to FCC Part 15 Section 15.209 Requirement

| Polarization | Frequency (MHz) | Reading (dBµV) | Pre-amp (dB) | Antenna Factor (dB) | Net at 3m (dBµV/m) | Limit at 3m (dBµV/m) | Margin (dB) |
|--------------|-----------------|----------------|--------------|---------------------|--------------------|----------------------|-------------|
| H | 31.455 | 25.0 | 16 | 10.0 | 19.0 | 40.0 | -21.0 |
| H | 245.704 | 14.5 | 16 | 20.0 | 18.5 | 46.0 | -27.5 |
| H | 344.644 | 13.4 | 16 | 24.0 | 21.4 | 46.0 | -24.6 |
| H | 491.114 | 16.0 | 16 | 26.0 | 26.0 | 46.0 | -20.0 |
| H | 661.349 | 20.1 | 16 | 29.0 | 33.1 | 46.0 | -12.9 |
| H | 955.259 | 17.7 | 16 | 33.0 | 34.7 | 46.0 | -11.3 |

- Notes: 1. Peak Detector Data unless otherwise stated.
2. All measurements were made at 3 meters.
3. Negative value in the margin column shows emission below limit.
4. Horn antenna is used for the emission over 1000MHz.
5. Emissions within the restricted band meet the requirement of FCC Part 15 Section 15.205.
6. Measurement Uncertainty is ±5.3dB at a level of confidence of 95%.

TEST REPORT

4.0 EQUIPMENT PHOTOGRAPHS

For electronic filing, the photographs are saved with filename: External Photos.pdf and Internal Photos.pdf.

5.0 PRODUCT LABELLING

For electronics filing, the FCC ID label artwork and the label location are saved with filename: Label.pdf.

6.0 TECHNICAL SPECIFICATIONS

For electronic filing, the block diagram and schematic of the tested EUT are saved with filename: Block.pdf and Circuit.pdf respectively.

7.0 INSTRUCTION MANUAL

For electronic filing, a preliminary copy of the Instruction Manual is saved with filename: Manual.pdf.

This manual will be provided to the end-user with each unit sold/leased in the United States.

TEST REPORT

8.0 MISCELLANEOUS INFORMATION

The miscellaneous information includes details of the test procedure and measured bandwidth.

8.1 Radiated Emission on the Bandedge

The emission of bandedge data were shown on the above radiated data table of 1 & 3 respectively.

Emissions radiated outside of the specified frequency bands, except harmonics, are attenuated by 50dB below the level of the fundamental or to the general radiated emissions limits in Section 15.209, whichever is the lesser attenuation, which meet the requirement of Part 15.249(d).

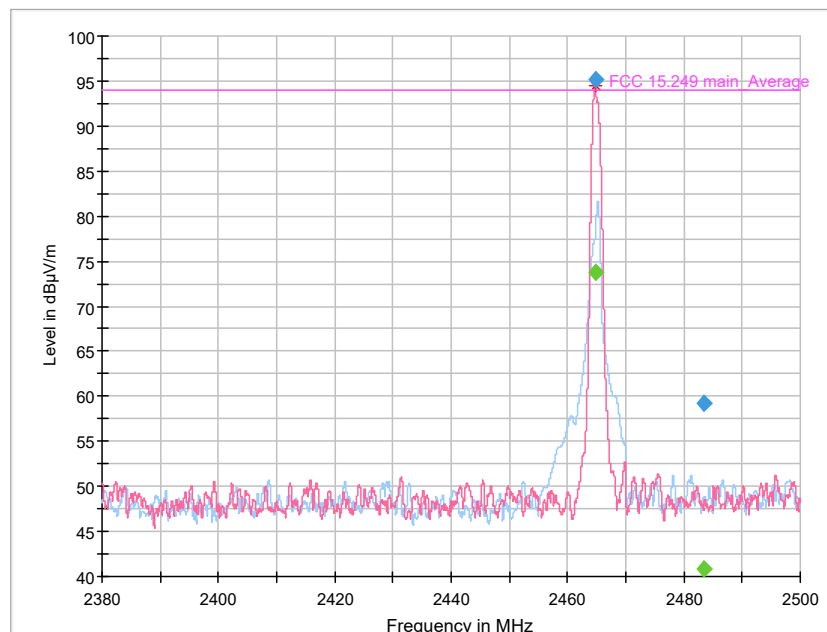
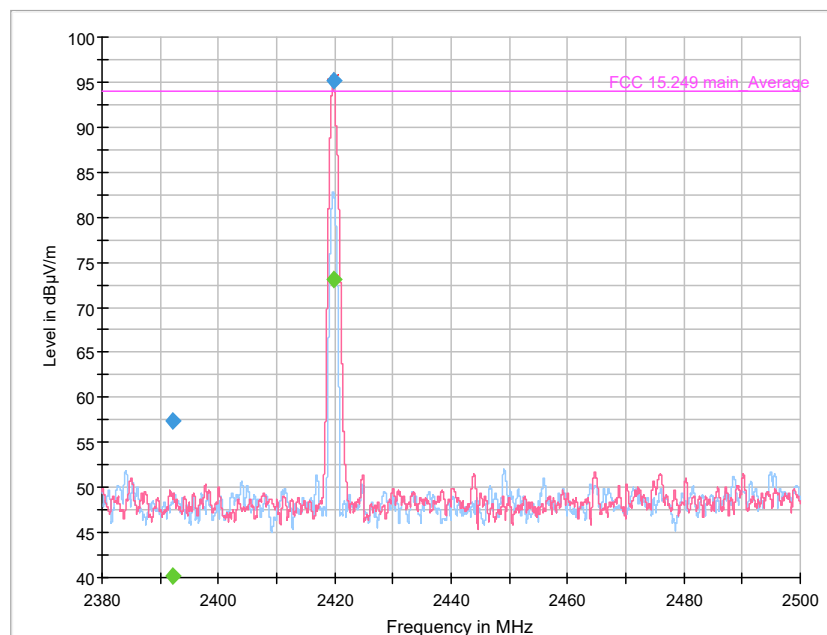

TEST REPORT

8.2 Emissions Test Procedures

The following is a description of the test procedure used by Intertek Testing Services Hong Kong Ltd. in the measurements of transmitter operating under the Part 15, Subpart C rules.

The transmitting equipment under test (EUT) is placed on a wooden turntable which is four feet in diameter and approximately 0.8m in height above the ground plane for emission measurement at or below 1GHz and 1.5m in height above the ground plane for emission measurement above 1GHz. During the radiated emissions test, the turntable is rotated and any cables leaving the EUT are manipulated to find the configuration resulting in maximum emissions. The EUT is adjusted through all three orthogonal axis to obtain maximum emission levels. The antenna height and polarization are also varied during the testing to search for maximum signal levels. The height of the antenna is varied from one to four meters.

Detector function for radiated emissions is in peak mode. Average readings, when required, are taken by measuring the duty cycle of the equipment under test and subtracting the corresponding amount in dB from the measured peak readings. A detailed description for the calculation of the average factor can be found in Exhibit 8.3.

The frequency range scanned is from the lowest radio frequency signal generated in the device which is greater than 9 kHz to the tenth harmonic of the highest fundamental frequency or 40 GHz, whichever is lower.

The EUT is warmed up for 15 minutes prior to the test.

AC power to the unit is varied from 85% to 115% nominal and variation in the fundamental emission field strength is recorded. If battery powered, a new, fully charged battery is used.

Conducted measurements were made as described in ANSI C63.10 (2013).

The IF bandwidth used for measurement of radiated signal strength was 100 kHz or greater when frequency is below 1000 MHz. Where pulsed transmissions of short enough pulse duration warrant, a greater bandwidth is selected according to the recommendations of Hewlett Packard Application Note 150-2. A discussion of whether pulse desensitivity is applicable to this unit is included in this report (See Exhibit 8.1). Above 1000 MHz, a resolution bandwidth of 3 MHz is used.

Transmitter measurements are normally conducted at a measurement distance of three meters. However, to assure low enough noise floor in the forbidden bands and above 1 GHz, signals are acquired at a distance of one meter or less. All measurements are extrapolated to three meters using inverse scaling, unless otherwise reported. Measurements taken at a closer distance are so marked.

TEST REPORT

8.2.1 Radiated Emission Test Setup

The figure below shows the test setup, which is utilized to make these measurements.

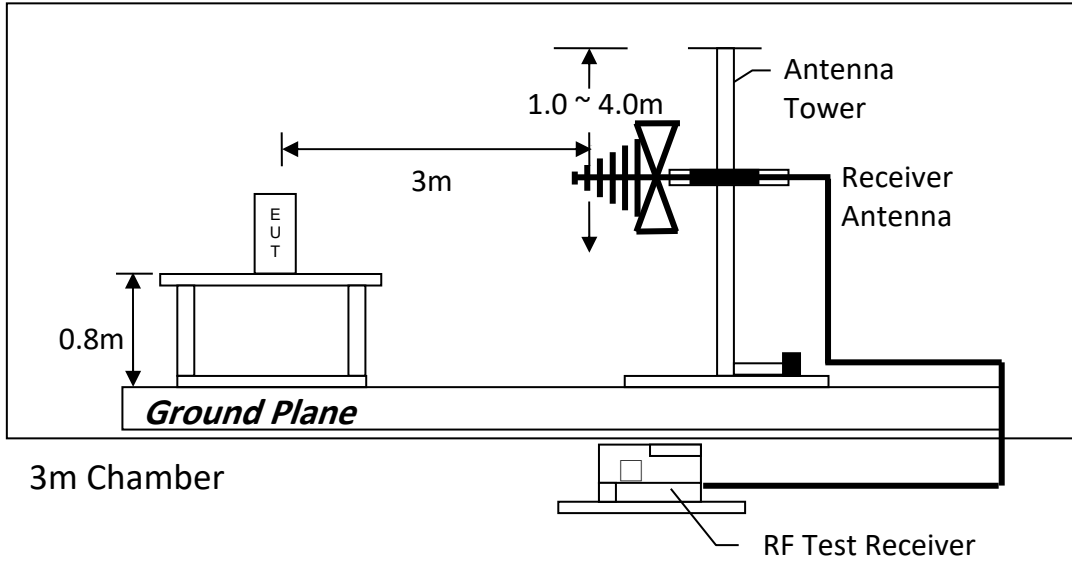

Test setup of radiated emissions up to 1GHz

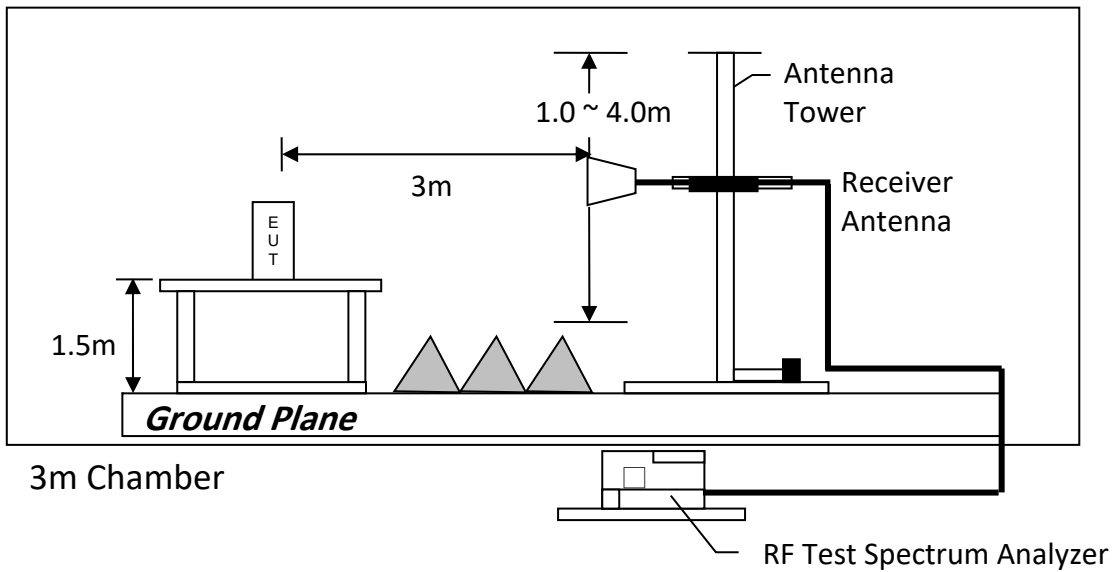

Test setup of radiated emissions above 1GHz

TEST REPORT

8.3 Occupied Bandwidth

Occupied Bandwidth Results:

| | Occupied Bandwidth (kHz) |
|----------------------|--------------------------|
| Low Channel: 2420 | 1120 |
| Middle Channel: 2442 | 1060 |
| High Channel: 2465 | 1120 |

The worst case is shown as below:

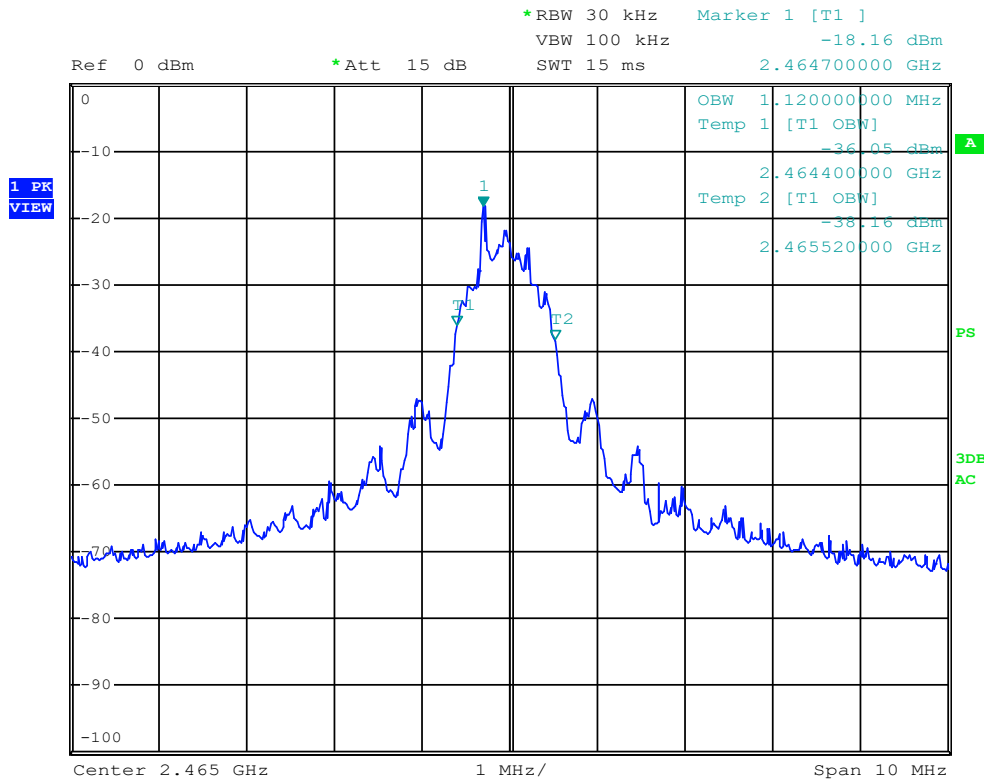

TEST REPORT

9.0 EQUIPMENT LIST

1) Radiated Emissions Test

| Equipment | Signal and Spectrum Analyzer (10Hz to 40GHz) | Biconical Antenna (30MHz to 300MHz) | EMI Test Receiver 7GHz |
|----------------------|--|-------------------------------------|------------------------|
| Registration No. | EW-3016 | EW-3242 | EW-3603 |
| Manufacturer | ROHDESCHWARZ | EMCO | ROHDESCHWARZ |
| Model No. | FSV40 | 3110C | ESR7 |
| Calibration Date | December 13, 2022 | May 26, 2021 | December 06, 2022 |
| Calibration Due Date | December 13, 2023 | August 26, 2023 | December 06, 2023 |

| Equipment | Log Periodic Antenna | Double Ridged Guide Antenna (1GHz - 18GHz) | Active Loop H-field (9kHz to 30MHz) |
|----------------------|----------------------|--|-------------------------------------|
| Registration No. | EW-3243 | EW-0194 | EW-3302 |
| Manufacturer | EMCO | EMCO | EMCO |
| Model No. | 3148B | 3115 | 6502 |
| Calibration Date | June 03, 2021 | May 10, 2023 | September 08, 2022 |
| Calibration Due Date | September 30, 2023 | November 10, 2024 | September 08, 2023 |

| Equipment | RF Preamp (9kHz to 6000MHz) | 2.4GHz Notch Filter | 14m Double Shield RF Cable (9kHz - 6GHz) |
|----------------------|-----------------------------|---------------------|--|
| Registration No. | EW-3006b | EW-3435 | EW-2376 |
| Manufacturer | SCHWARZBECK | MICROWAVE | RADIALL |
| Model No. | BBV9718 | N0324413 | n m/br56/bnc m 14m |
| Calibration Date | February 15, 2022 | June 16, 2022 | January 26, 2022 |
| Calibration Due Date | August 15, 2023 | September 16, 2023 | October 26, 2023 |

| Equipment | RF Cable 14m (1GHz to 26.5GHz) | 14m Double Shield RF Cable (20MHz to 6GHz) | Pyramidal Horn Antenna |
|----------------------|--------------------------------|--|------------------------|
| Registration No. | EW-2781 | EW-2074 | EW-0905 |
| Manufacturer | GREATBILLION | RADIALL | EMCO |
| Model No. | SMA m/SHF5MPU /SMA m ra14m,26G | N(m)-RG142-BNC(m) L=14M | 3160-09 |
| Calibration Date | December 12, 2022 | December 10, 2021 | July 20, 2021 |
| Calibration Due Date | December 12, 2023 | September 10, 2023 | August 20, 2023 |

TEST REPORT

2) Bandedge Measurement

| Equipment | EMI Test Receiver (9kHz to 26.5GHz) | 5m RF Cable (40GHz) |
|----------------------|--|----------------------------|
| Registration No. | EW-3156 | EW-2701 |
| Manufacturer | ROHDESCHWARZ | RADIALL |
| Model No. | ESR26 | Sma m-m 5m 40G |
| Calibration Date | September 26, 2022 | November 24, 2021 |
| Calibration Due Date | September 26, 2023 | August 24, 2023 |

3) OBW Measurement

| Equipment | EMI Test Receiver (9kHz to 26.5GHz) |
|----------------------|--|
| Registration No. | EW-3156 |
| Manufacturer | ROHDESCHWARZ |
| Model No. | ESR26 |
| Calibration Date | September 26, 2022 |
| Calibration Due Date | September 26, 2023 |

4) Control Software for Radiated Emission

| Software Information | |
|-----------------------------|--------------|
| Software Name | EMC32 |
| Manufacturer | ROHDESCHWARZ |
| Software version | 10.50.40 |

END OF TEST REPORT